

- **Motor**
- Alternator
- Machine Tool

请注意：本样本之数据仅供参考，因产品不断完善，技术数据可能随时更改，如有疑问，请与我司联系。

Please note: The technical data in this catalogue only for reference, continuous development of our product entitles us to change the specification without notice, if any doubt, please contact with us.

2015版
2015 Version



简介

Brief introduction

公司位于苏州市国家级高新技术产业开发区——珠江路，公司自创立以来，坚持高标准、高质量、高效率的企业发展方针，致力于发电机、机床装备相关产品的研发销售，是一家集电机和发电机制造、销售、科研为一体的创新型科技企业。拥有国家发明专利2项，“凯捷利”品牌的产品远销欧洲、南美、中东、南亚、东南亚等50多个国家和地区，并在国内外建立了稳固的销售渠道，设品牌代理50余家，年销售额逐年增长，成为行业内的领军企业。

KAIGONG ELECTRIC (SUZHOU) CO.,LTD is located in Zhujiang Road, New District, Suzhou. We always adhere to the policy of high standard, high quality and high efficiency and devoted ourselves to the research and sales of the generators, machine tools and their spare parts. It is a creative technology company comprising the manufacture, sales and research of electric motors and generators. We have 2 national invention patents. Our products in "KAIJIELI" brand are exported to more than 50 countries and districts in Europe, South America, Middle East, South Asia, Southeast Asia etc. We have steady sales channels and more than 50 agencies both at home and abroad. It is the leading company in the industry and the total annual sales is Keeping growing.

公司秉承“务实，创新，开拓”的企业精神，坚持“为客户提供优质可靠产品”的经营理念，引进优秀的技术专业人才、先进设备，拥有雄厚的技术力量和严谨高效的技术研发团队。先后生产的CDF、KE、KE3系列普通电动机、高效电动机和超高效电动机，符合欧盟最新的能效标准，走在了市场前列；ST、STC系列有刷发电机的生产和销售，多年来一直稳居国内第一；TWGII系列无刷发电机采用自主研发的多项专利技术，成为了引领潮流的新一代发电机产品。

We adhere to the spirit of pragmatism, creation and pioneering, adhere to the operation philosophy of supplying high quality products to the customers and attach great importance to the talent introduction and advanced equipment. We have strong technical force, rigorous and efficient technology research team. The ordinary motors of CDF series, high efficiency motors of KE series and ultrahigh efficiency motors of KE3 series are in accordance with the latest EU standards and take the leading position in the market. The manufacture and sales of the ST STC series generators with brush ranked the first steadily in domestic market for years. TWGII series brushless generators became the new generation generators which set the trend thanks to several patented technology of our independent research.

凯工电气以打造“中国最佳”为努力方向，以“满足客户要求”为员工职责，以“战胜竞争”为团队荣耀，以“利益共赢”为最终目标。并与国内外知名企业建立了战略合作关系，期望与更多新老客户携手真诚合作。

Kaigong takes "creating the best in China" as the direction, "satisfying the customers" as the stuff duty, "beating the competitors" as the glory and "getting win-win situation" as the ultimate goal. We have built strategic cooperation relationship with domestic and overseas well-known enterprises and sincerely hope to cooperate with more new and old customers.



www.famcocorp.com

E-mail: info@famcocorp.com

@famco_group

Tel: +86-512-4800049

Fax: +86-512-44994642

目录 Contents

CDF SDF 系列三相异步电动机 SERIES THREE-PHASE ASYNCHRONOUS INDUCTION MOTOR	02
KE 系列高效三相异步电动机 SERIES HIGH-EFFICIENCY THREE-PHASE ASYNCHRONOUS INDUCTION MOTOR	09
KE3 系列超高效三相异步电动机 SERIES ULTRA-HIGH-EFFICIENCY THREE-PHASE ASYNCHRONOUS INDUCTION MOTOR	18
YC 系列大马力单相电容启动异步电动机 SERIES HEAVY-DUTY SINGLE-PHASE CAPACITOR START INDUCTION MOTOR	24
YCL 系列大马力单相电容启动运转异步电动机 SERIES HEAVY-DUTY SINGLE-PHASE CAPACITOR START AND RUN INDUCTION MOTOR	24
Y2 中型低压大功率三相异步电动机 SERIES MEDIUM-SIZE LOW-VOLTAGE THREE-PHASE ASYNCHRONOUS MOTOR	27
YKK 系列6kV/10kV中型高压三相异步电动机 SERIES 6KV/10KV MEDIUM-SIZE HIGH-VOLTAGE THREE-PHASE ASYNCHRONOUS MOTOR	29

تهران، کیلومتر ۲۱ بزرگراه لشکری (جاده مخصوص کرج)

روبروی پالایشگاه نفت پارس، پلاک ۱۳

Y2系列基础上专为欧美市场设计的新款电机。其功率等级欧洲EFF2标准，并可按要求达到EFF1标准。采用F级绝缘ISKF或NSK、NTN轴承，160及以上带注油嘴结构。

Adopting the national uniform design, Y2 series three-phase induction motors are in conformity with IEC 34-1 and JB/T8680 standards, also up to the international advanced level of the 90's. As the substitute of Y series induction motors, it possesses sophisticated features such as new construction, good appearance, slight vibration, low noise etc. CDF, SDF series three phase motors are newly designed by our company for the European and American markets on the basis of Y2 series. Its rated power and mounting sizes are quite same as Y2 series. The efficiency of CDF and SDF can meet standards of EFF2 and EFF1. The motors are adopted in class F (Temperature rise B) insulation and IP55 protection. Motors can be equipped with PTC, as well as re-greasing system for frame size 160 and above, bearings of SKF, NSK or NTN at optional.

使用条件 OPERATING CONDITIONS

环境温度: $-15^{\circ}\text{C} < \text{q} < 40^{\circ}\text{C}$ 海拔: 不超过1000m
 额定电压: 380V, 可选220-760V之间任何电压值。
 额定频率: 50Hz、60Hz 防护等级: IP54、IP55 绝缘等级: F级、H级
 冷却方式: IC 411 工作方式: 连续S1
 接法: 3kW及以下Y接法, 4kW及以上为△接法。
 其它: 可任意选择左、右、顶部出线方式和开口槽、闭口槽结构, 可附带PTC热敏电阻, 160及以上可带注油嘴结构。
 Ambient temperature: $-15^{\circ}\text{C} < \text{q} < 40^{\circ}\text{C}$ Altitude: not exceed 1000m
 Rated voltage: 380V or any voltage between 220V-760V.
 Rated frequency: 50Hz, 60Hz Protection class: IP54, IP55
 Insulation class: F, H Cooling method: IC 411 Duty: S1(continuous)
 Connection: Star-connection for up to 3kW, delta-connection for 4kW and above
 Remark: Terminal box on top, right or left side are available. Key-way can be closed type or open type. Motors can also be equipped with PTC, as well as re-greasing system for frame size 160 and above.

CDF

SDF 系列三相异步电动机

SERIES THREE-PHASE ASYNCHRONOUS INDUCTION MOTOR

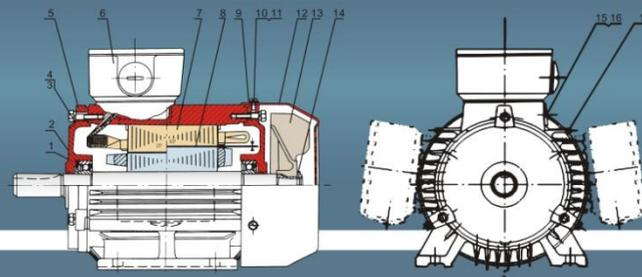

SDF



CDF

MATERIAL TABLE

Description		Description		Description	
1	轴承 Bearing	6	接线盒 Terminal Box	11	垫圈 Washer
2	波形垫圈 Wave-form washer	7	定子 Stator pack with winding	12	风罩 Fan cowl
3	螺栓 Bolt	8	转子 Rotor	13	风扇 Fan
4	弹簧垫圈 Spring washer	9	后前盖 NDE shield	14	挡圈 Circlip
5	前端盖 DE shield	10	螺钉 Screw	15	铭牌 Nameplate
				16	铆钉 Rivet
				17	机座 Frame
				18	
				19	
				20	

轴承规格 BEARING SIZE

机座号 Frame size	极数 Poles	CDF系列轴承 CDF Series Bearing		SDF系列轴承 SDF Series Bearing	
		轴伸端 Drive End	非轴伸端 Non-Drive End	轴伸端 Drive End	非轴伸端 Non-Drive End
63	2-4	6201	6201	6201	6201
71	2-6	6202	6202	6202	6202
80	2-8	6204	6204	6204	6204
90	2-8	6205	6205	6205	6205
100	2-8	6206	6206	6206	6206
112	2-8	6206	6206	6206	6206
132	2-8	6208	6208	6208	6208
160	2-8	6309	6309	6309	6309
180	2	6211	6211	6211	6211
	4-8	6311	6211	6311	6211
200	2	6212	6212	6212	6212
	4-8	6312	6212	6312	6212
225	2	6312	6312	6312	6312
	4-8	6313	6313	6313	6313
250	2	6313	6313	6313	6313
	4-8	6314	6314	6314	6314
280	2	6314	6314	6314	6314
	4-8	6317	6314	6317	6314
315	2	6317	6317	6317	6317
	4-10	6319	6319	6319	6319
	2	6319	6319	6319	6319
355	4-10	Nu322	6322	Nu322	6322

SERIES THREE-PHASE ASYNCHRONOUS INDUCTION MOTOR

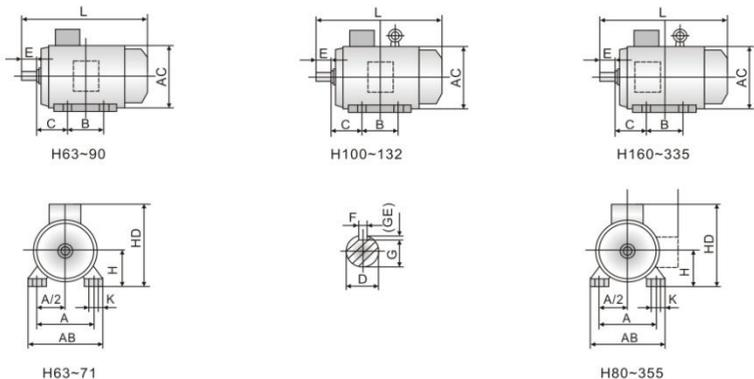

机座带底脚，端盖上有凸缘的电动机 Frame with feet and endshield with flange (with plain holes)

机座号 Frame size	极数 Poles	安装尺寸 Mounting dimensions											外形尺寸 Overall dimensions				
		A	A/2	B	C	D	E	F	G	H	K	AB	AC	AD	HD	L	
63	2, 4	100	50	80	40	11	23	4	8.5	63	7	135	130	70	180	225	
71	2, 4, 6	112	56	90	45	14	30	5	11	71	7	150	145	80	195	250	
80	2	125	62.5	100	50	19	40	6	15.5	80	10	165	175	145	214	295	
90S	2	140	70	125	56	24	50				10	180	195	155	250	315	
90L	2	160	80	140	63	28	60				12	205	215	180	270	385	
100L	2	190	95	140	70	28	60				12	230	240	190	300	400	
112M	2	216	108	178	89	38	80	10	33	132	12	270	275	210	345	470	
132S	2, 4, 6, 8	254	127	210	108	42	12	37	160		15	320	330	255	420	615	
132M	2	279	139.5	241	121	48	110				15	355	380	280	455	700	
160M	2	318	159	305	133	55					16	420	420	305	505	770	
160L	2	254	127	210	108	42	12	37	160		15	320	330	255	420	615	
180M	2	279	139.5	241	121	48	110				15	355	380	280	455	700	
180L	2	318	159	305	133	55					16	420	420	305	505	770	
200L	2	356	178	311	149	55	110	16	49	200	0	435	470	335	555	815	
225S	4, 8	286			60	140	18	53			19	435	470	335	555	815	
225M	2	356	178	311	149	55	110	16	49	225	19	435	470	335	555	815	
250M	2	406	203	349	168			53			250	490	510	370	615	910	
280S	2	406	203	349	168			53			250	490	510	370	615	910	
280M	2	457	228.5	368		140		58			280	550	580	410	680	985	
315S	2	457	228.5	368		140		58			280	550	580	410	680	985	
315M	2	508	254	457	216			58			315	600	645	530	845	1160	
315L	2	508	254	457	216			58			315	600	645	530	845	1160	
355M	2	610	305	560		170	22	71			355	730	770	655	1010	1500	
355L	2	610	305	560		170	22	71			355	730	770	655	1010	1500	

www.famcocorp.com

E-mail: info@famcocorp.com

@famco_group

Tel: +91-44-0000-49

Fax: +91-44-994644

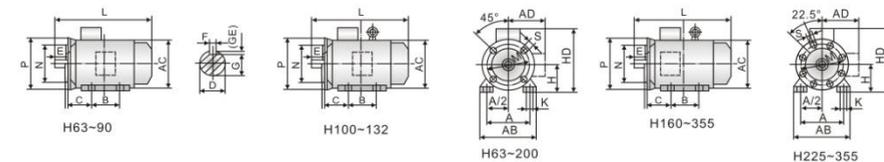

机座带底脚，端盖上有凸缘（带通孔）的电动机 Frame with feet and endshield with flange (with plain holes)

机座号 Frame size	凸缘号 Flange NO.	极数 Poles	安装尺寸 Mounting dimensions											外形尺寸 Overall dimensions										
			A	A/2	B	C	D	E	F	G	H	K	M	N	P	R*	S	T	凸缘孔径 Flange holes	AB	AC	AD	HD	L
63	FF115	2, 4	100	50	80	40	11	23	4	8.5	63	7	115	95	140					135	130	70	180	225
71	FF130	2, 4, 6	112	56	90	45	14	30	5	11	71	7	130	110	160					150	145	80	195	250
80	2	125	62.5	100	50	19	40	6	15.5	80	10	165	175	145	214				165	175	145	214	295	
90S	FF165	2	140	70	125	56	24	50			20	90	10	165	130	200				180	195	155	250	315
90L	2	160	80	140	63	28	60				8	20	10	165	130	200				180	195	155	250	315
100L	FF215	2	190	95	140	70	28	60			24	112	12	215	180	250				205	215	180	270	385
112M	2	216	108	178	89	38	80	10	33	132			12	270	275	210	345			230	240	190	300	400
132S	FF265	2, 4, 6, 8	254	127	210	108	42	12	37	160			15	300	250	350				270	275	210	345	510
132M	2	279	139.5	241	121	48	110				14	42.5	180							230	240	190	300	400
160M	FF300	2	318	159	305	133	55				16	49	200							320	330	255	420	615
160L	2	254	127	210	108	42	12	37	160		15	300	250	350						320	330	255	420	615
180M	2	279	139.5	241	121	48	110				14	42.5	180							335	380	280	455	700
180L	2	318	159	305	133	55					16	49	200							335	380	280	455	700
200L	FF350	4, 6	356	178	311	149	55	110	16	49	225	19	400	350	450					395	420	305	505	770
225S	2	286			60	140	18	53																815
225M	2	356	178	311	149	55	110	16	49	225	19	400	350	450										815
250M	2	406	203	349	168			53			250													845
280S	2	406	203	349	168			53			250													845
280M	2	457	228.5	368		140		58			280													845
315S	2	457	228.5	368		140		58			280													845
315M	2	508	254	457	216			58			315													845
315L	2	508	254	457	216			58			315													845
355M	2	610	305	560		170	22	71			355													845
355L	2	610	305	560		170	22	71			355													845

注: *R为凸缘配合面至轴伸肩的距离。 Note: R is the distance from the flange mounting-plane to the shaft-extension shoulder.

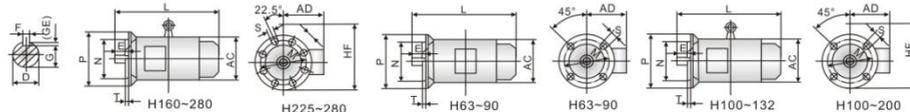

机座不带底脚，端盖上有凸缘（带通孔）的电动机 Frame without feet and endshield with flange (with thread holes)

机座号 Frame size	凸缘号 Flange NO.	极数 Poles	安装尺寸 Mounting dimensions											外形尺寸 Overall dimensions										
			D	E	F	G	M	N	P	R*	S	T	凸缘孔径 Flange holes	AC	AD	HF	L							
63	FF115	2, 4	11	23	4	8.5	115	95	140											130	70	130	225	
71	FF130	2, 4, 6	14	30	5	11	130	110	160												145	80	145	250
80	2	19	40	6	15.5	80															175	145	185	295
90S	FF165	2	24	50		20	165	130	200												195	155	195	315
90L	2	28	60	8	24	215	160	250													195	155	195	315
100L	FF215	2	28	60	8	24	215	160	250												215	180	245	385
112M	2	38	80	10	33	265	230	300													240	190	265	400
132S	FF265	2, 4, 6, 8	42	12	37	160															275	210	315	510
132M	2	42	12	37	160																275	210	315	510
160M	FF300	2	48	110	14	42.5	300	250	350												330	255	385	615
160L	2	48	110	14	42.5	300	250	350													330	255	385	615
180M	2	55	110	16	49	350	300	400													380	280	430	740
180L	2	55	110	16	49	350	300	400													380	280	430	740
200L	FF350	4, 8	60	140	18	53															420	305	480	770
225S	2	60	140	18	53																420	305	480	770
225M	2	55	110	16	49	400	350	450													420	305	480	770
250M	2	60			53																470	335	535	820
280S	2	65			58																470	335	535	820
280M	2	65			58																470	335	535	820
315M	2	75	140	20	67.5	500	450	550													510	370	595	910
315L	2	75	140	20	67.5	500	450	550													510	370	595	910
355M	2	75	140	20	67.5	500	450	550													580	410	650	985
355L	2	75	140	20	67.5	500	450	550													580	410	650	985

Distance from the flange mounting-plane to the shaft-extension shoulder.

نورمان، کیولومتر ۲۱ بزنگراه لشکری (جاده مخصوص کرج)

روبروی پالایشگاه نفت پارس، پلاک ۱۳

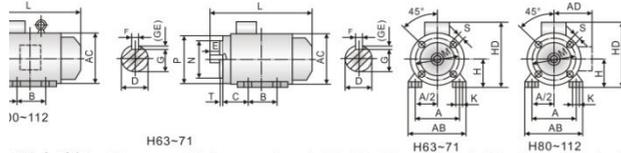

H63-71 H80-112
).的电动机 Frame with feet and endshield with flange (with thread holes)

机座号 Frame size	凸缘号 Flange NO.	极数 Poles	安装尺寸 Mounting dimensions										外形尺寸 Overall dimensions						
			D	E	F	G	M	N	P	R+	S	T	凸缘孔数 Flangeholes	AC	AD	HD	L		
63	FT75	2,4	11	23	4	8.5	75	60	90			M5	2.5	4	135	130	70	180	225
71	FT85	2,4,6	14	30	5	11	85	70	105			M6	2.5	4	150	145	80	195	250
80	FT100	2,4,6,8	19	40	6	15.5	100	80	120			M6	2.5	4	165	175	145	214	295
90S	FT115	2,4,6,8	24	50	8	20	115	95	140			M8	3.0	4	180	195	155	250	315
90L	FT130	2,4,6,8	28	60	8	24	130	110	160			M8	3.5	4	205	215	180	270	340
100L	FT130	2,4,6,8	28	60	8	24	130	110	160			M8	3.5	4	230	240	190	300	400
112M	FT165	2,4,6,8	38	80	10	33	165	130	200			M10	3.5	4	270	275	210	345	470
132S	FT165	2,4,6,8	38	80	10	33	165	130	200			M10	3.5	4	270	275	210	345	470
132M	FT165	2,4,6,8	38	80	10	33	165	130	200			M10	3.5	4	270	275	210	345	470

注: *R为凸缘配合面至轴伸肩的距离。 Note: R is the distance from the flange mounting-plane to the shaft-extension shoulder.

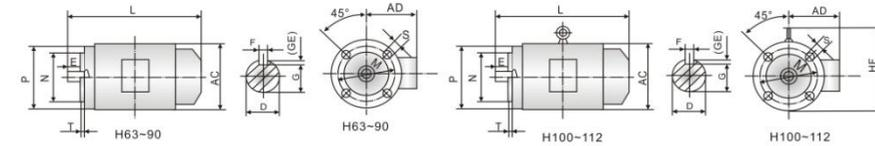

H63-90 H100-112
机座不带底脚, 端盖上有凸缘(带螺孔)的电动机 Frame without feet and endshield with flange (with thread holes)

机座号 Frame size	凸缘号 Flange NO.	极数 Poles	安装尺寸 Mounting dimensions										外形尺寸 Overall dimensions					
			D	E	F	G	M	N	P	R+	S	T	凸缘孔数 Flangeholes	AC	AD	HF	L	
63	FT75	2,4	11	23	4	8.5	75	60	90			M6	2.5	4	130	70	130	225
71	FT85	2,4,6	14	30	5	11	85	70	105			M6	2.5	4	145	80	145	250
80	FT100	2,4,6,8	19	40	6	15.5	100	80	120			M6	2.5	4	175	145	185	290
90S	FT115	2,4,6,8	24	50	8	20	115	95	140			M8	3.0	4	195	155	190	315
90L	FT130	2,4,6,8	28	60	8	24	130	110	160			M8	3.5	4	215	180	245	380
100L	FT130	2,4,6,8	28	60	8	24	130	110	160			M8	3.5	4	240	190	265	400
112M	FT165	2,4,6,8	38	80	10	33	165	130	200			M10	3.5	4	275	210	315	470
132S	FT165	2,4,6,8	38	80	10	33	165	130	200			M10	3.5	4	275	210	315	470
132M	FT165	2,4,6,8	38	80	10	33	165	130	200			M10	3.5	4	275	210	315	470

注: *R为凸缘配合面至轴伸肩的距离。 Note: R is the distance from the flange mounting-plane to the shaft-extension shoulder.

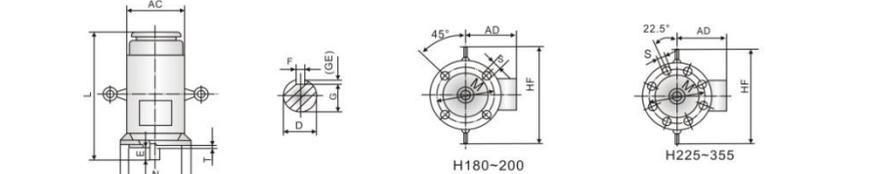

立体安装, 机座不带底脚, 端盖上有凸缘(带通孔), 轴伸向下的电动机
Vertical type, frame without feet and endshield with flange (with thread holes)

机座号 Frame size	凸缘号 Flange NO.	极数 Poles	安装尺寸 Mounting dimensions										外形尺寸 Overall dimensions					
			D	E	F	G	M	N	P	R+	S	T	凸缘孔数 Flangeholes	AC	AD	HF	L	
180M	FF300	2,4,6,8	48	110	14	42.5	300	250	350					4	380	280	500	760
200L	FF350	2,4,6,8	55	140	16	49	350	300	400					4	420	305	550	840
225S	FF400	2,4,6,8	60	140	18	53	400	350	450					4	470	335	610	905
225M	FF400	2,4,6,8	60	140	18	53	400	350	450					4	470	335	610	905
250M	FF400	2,4,6,8	60	140	18	53	400	350	450					4	510	370	650	1015
250M	FF400	2,4,6,8	65	140	18	58	400	350	450					4	510	370	650	1015
280S	FF500	2,4,6,8	75	140	20	67.5	500	450	550					4	580	410	720	1110
280M	FF500	2,4,6,8	75	140	20	67.5	500	450	550					4	580	410	720	1110
315S	FF600	2,4,6,8,10	80	170	22	71	600	550	660					4	645	530	900	1280
315M	FF600	2,4,6,8,10	80	170	22	71	600	550	660					4	645	530	900	1280
315L	FF600	2,4,6,8,10	80	170	22	71	600	550	660					4	645	530	900	1280
355M	FF740	2,4,6,8,10	95	170	25	86	740	680	800					4	710	655	1010	1670
355L	FF740	2,4,6,8,10	95	170	25	86	740	680	800					4	710	655	1010	1670

注: *R为凸缘配合面至轴伸肩的距离。 Note: R is the distance from the flange mounting-plane to the shaft-extension shoulder.

CDF SDF 技术数据 TECHNICAL DATA OF CDF SDF

型号 Model	功率 Output		电流 Current (A)		转速 Speed (r/min)	效率 Efficiency (%)	功率因素 Power Factor	堵转转矩 额定转矩 Tstart/Tn	堵转电流 额定电流 Ist/In	最大转矩 额定转矩 Tmax/Tn
	kW	HP	380V	400V						
同步转速3000转/分 (2级) 380V 50Hz Synchronous Speed 3000 r/min (2 Poles)										
631-2	0.18	0.24	0.53	0.50	2730	65.0	0.80	2.2	5.5	2.2
632-2	0.25	0.33	0.66	0.60	2730	40.0	8.81	2.6	5.5	2.6
711-2	0.37	0.50	0.95	0.90	2750	72.3	0.82	2.4	6.1	2.5
712-2	0.55	0.75	1.33	1.26	2790	76.0	0.82	2.4	6.1	2.9
801-2	0.75	1	1.83	1.71	2845	76.1	0.83	2.4	7.0	2.5
802-2	1.1	1.5	2.60	2.5	2840	76.2	0.83	2.5	7.0	2.5
90S-2	1.5	2	3.50	3.3	2840	78.8	0.84	2.7	7.0	2.8
90L-2	2.2	3	4.80	4.6	2840	81.0	0.84	2.5	6.0	2.8
100L-2	3.0	4	6.40	6.1	2830	82.8	0.87	2.2	7.5	2.5
112M-2	4.0	5.5	8.10	7.7	2890	84.2	0.88	2.3	7.1	2.3
132S1-2	5.5	7.5	11.0	10.5	2910	85.9	0.88	2.3	7.5	2.5
132S1-2	7.5	10	15.0	14.3	2905	87.3	0.88	2.2	7.5	2.4
160M1-2	11	15	22.0	20	2935	88.6	0.89	2.3	7.7	3.1
160M2-2	15	20	29.0	27	2935	89.4	0.90	2.4	7.6	3.1
160L-2	18.5	25	35.0	33	2935	90.1	0.91	2.7	7.7	3.2
180M-2	22	30	41.0	39	2940	90.6	0.90	2.0	7.7	2.7
200L1-2	30	40	56.0	53	2945	91.6	0.90	2.1	6.9	2.8
200L2-2	37	50	68.0	64	2945	92.2	0.90	2.2	7.0	2.6
225M-2	45	60	81.0	77	2950	92.7	0.90	2.4	7.3	3.1
250M-2	55	75	100	95	2965	93.1	0.90	2.6	7.6	3.1
280S-2	75	100	134	127	2965	93.8	0.91	2.2	7.8	2.5
280M-2	90	125	160	152	2965	94.4	0.91	2.2	7.8	2.5
315S-2	110	150	196	186	2975	94.4	0.91	1.8	7.1	2.4
315M-2	132	180	234	222	2975	94.9	0.91	1.8	7.1	2.4
315L1-2	160	215	280	266	2975	95.1	0.92	1.8	7.1	2.5
315L2-2	200	270	348	331	2975	95.2	0.90	1.8	7.1	2.5
355M-2	250	340	430	410	2970	95.3	0.90	1.6	7.3	2.2
355L-2	315	420	543	515	2970	95.6	0.92	1.6	7.3	2.2
同步转速1500转/分 (4级) 380V 50Hz Synchronous Speed 1500 r/min (4 Poles)										
631-4	0.12	0.16	0.44	0.42	1320	57.0	0.72	2.4	5.2	2.2
632-4	0.18	0.24	0.53	0.60	1320	60.0	0.72	2.4	5.2	2.5
711-4	0.25	0.33	0.73	0.79	1350	65.0	0.70	2.5	5.2	3.0
712-4	0.37	0.50	1.10	1.0	1340	67.0	0.75	2.5	5.2	3.1
801-4	0.55	0.75	1.50	1.4	1390	71.0	0.77	2.5	5.3	2.5
802-4	0.75	1.0	2.0	1.9	1380	74.4	0.77	2.5	5.3	2.5
90S-4	1.1	1.5	3.0	2.9	1390	76.3	0.75	2.5	4.7	2.3
90L-4	1.5	2	3.9	3.7	1390	78.5	0.76	2.2	5.2	2.6
100L1-4	2.2	3	5.2	4.9	1410	81.2	0.81	2.3	6.8	2.5
100L2-4	3.0	4	6.8	6.5	1410	82.8	0.82	2.3	7.1	2.5
112M-4	4.0	5.5	8.7	8.3	1440	84.2	0.82	2.3	6.4	2.6
132S-4	5.5	7.6	12	11	1445	85.7	0.83	2.3	7.0	2.5
132M-4	7.5	10	16	15	1445	87.2	0.84	2.3	7.0	2.5
160M-4	11	15	23	22	1480	88.4	0.85	2.4	7.0	2.9
160L-4	15	20	30	28	1480	89.5	0.85	2.6	7.6	2.9
180M-4	18.5	25	36	34	1470	90.2	0.87	2.2	7.0	3.0
180L-4	22	30	42	40	1470	90.6	0.87	2.2	7.0	2.7
200L-4	30	40	58	55	1470	91.4	0.86	2.2	7.2	3.0
225S-4	37	50	70	66	1475	92.2	0.87	2.2	6.9	2.8
225M-4	45	60	85	80	1475	92.5	0.87	2.2	7.0	3.0
250M-4	55	75	106	98	1475	93.1	0.87	2.2	7.4	2.8
280S-4	75	100	140	133	1485	93.7	0.87	2.2	7.5	2.4
280M-4	90	125	167	159	1485	93.9	0.87	2.2	7.5	2.4
315S-4	110	150	201	191	1485	94.5	0.88	2.2	6.9	2.7
315M-4	132	180	241	227	1485	94.8	0.88	2.2	6.9	2.6
315L1-4	160	220	288	273	1485	95.1	0.89	2.2	6.9	2.4
315L2-4	200	270	350	342	1485	95.2	0.89	2.2	6.9	2.4
355M-4	250	340	440	415	1490	95.3	0.91	2.3	6.8	2.3
355L-4	315	420	550	520	1490	95.6	0.91	2.3	6.8	2.3

TECHNICAL DATA OF CDF SDF

Model	Current (A)		Speed (r/min)	Efficiency (%)	Power Factor	Start Torque (Tstart/Tn)	Rated Current (Ist/In)	Max Torque (Tmax/Tn)		
	380 V	400 V								
000转/分 (6极) 380V 50Hz Synchronous Speed 3000 r/min (6 Poles)										
711-6	0.18	0.24	0.70	0.67	865	59.0	0.66	2.3	4.0	2.4
712-6	0.25	0.33	0.90	0.83	885	64.0	0.68	2.0	4.0	2.0
801-6	0.37	0.50	1.20	1.1	885	62.5	0.76	2.0	4.7	2.1
802-6	0.55	0.75	1.70	1.5	885	69.0	0.76	2.0	4.7	2.1
90S-6	0.75	1	2.40	2.3	915	72.4	0.71	2.0	5.5	2.2
90L-6	1.1	1.5	3.30	3.1	915	75.2	0.72	2.0	5.5	2.2
100L-6	1.5	2	4.00	3.7	940	77.4	0.76	2.1	6.2	2.2
112M-6	2.2	3	5.50	5.0	980	79.8	0.76	2.2	5.0	2.2
132S-6	3.0	4	7.50	7.0	960	81.4	0.76	2.2	6.3	2.8
132M1-6	4.0	5.5	10.0	9.5	960	83.2	0.76	2.4	6.4	2.9
132M2-6	5.5	7.5	13.0	12	960	84.6	0.77	2.4	6.5	2.8
160M-6	7.5	10	17.0	16	670	86.2	0.78	2.0	6.5	2.3
160L-6	11	15	24.0	23	970	87.6	0.79	2.0	6.5	2.3
180L-6	15	20	31.0	29	970	88.9	0.83	2.1	7.0	2.2
200L1-6	18.5	25	38.0	38	975	89.6	0.82	2.1	6.5	2.8
200L1-6	22	30	45.0	42	975	90.4	0.83	2.1	6.5	2.7
225M-6	30	40	58.0	55	980	91.1	0.85	2.1	6.9	2.5
250M-6	37	50	71.0	68	980	91.7	0.86	2.3	6.9	2.3
280S-6	45	60	86.0	82	980	92.3	0.86	2.3	7.0	2.7
280M-6	55	75	105	100	980	92.8	0.86	2.3	7.0	2.7
315S-6	75	100	142	135	980	93.6	0.86	2.0	7.0	2.4
315M-6	90	125	170	160	935	93.9	0.86	2.0	7.0	2.4
315L1-6	110	150	207	197	935	94.3	0.86	2.4	7.0	2.4
315L2-6	132	180	245	233	935	94.8	0.87	2.1	7.0	2.3
355M1-6	160	220	293	277	935	94.9	0.88	2.0	7.0	2.0
355M2-6	200	270	363	345	990	95.0	0.88	2.0	7.0	2.0
355L-6	250	340	450	425	990	95.0	0.89	2.3	7.0	2.5
同步转速750转/分 (8极) 380V 50Hz Synchronous Speed 750 r/min (8 Poles)										
801-8	0.18	0.25	0.82	0.78	630	52.0	0.64	1.8	3.5	2.0
802-8	0.25	0.34	1.10	1.0	640	54.0	0.64	1.8	3.5	2.0
90S-8	0.37	0.50	1.60	1.5	660	59.0	0.60	1.9	4.0	2.3
90L-8	0.55	0.75	2.20	2.1	660	62.0	0.60	2.0	4.0	2.3
100L1-8	0.75	1	2.40	2.3	690	68.4	0.67	2.0	5.0	2.2
100L2-8	1.1	1.5	3.40	3.2	690	71.6	0.69	1.8	5.0	2.2
112M-8	1.5	2	4.00	3.8	680	74.6	0.75	2.0	5.0	2.6
132S-8	2.2	3	6.00	5.7	710	77.8	0.71	1.8	6.0	2.5
132M-8	3.0	4	7.90	7.5	710	79.8	0.73	1.8	6.0	2.4
160M1-8	4.0	5.5	10.3	9.8	720	81.5	0.73	1.9	6.0	2.0
160M2-8	5.5	7.5	13.6	12.8	720	83.4	0.71	2.0	6.0	2.0
160L-8	7.5	10	18.0	17	720	85.5	0.75	2.0	6.0	2.0
180L-8	11	15	25.0	24	730	87.0	0.76	2.2	6.2	2.0
200L-8	15	20	35.0	32	730	88.5	0.76	2.2	6.2	2.8
225S-8	18.5	25	40.1	38	730	89.6	0.77	2.2	6.8	2.8
225M-8	22	30	47.0	44	740	89.7	0.80	2.2	6.7	2.3
250M-8	30	40	63.0	60	740	90.9	0.80	1.9	5.5	2.9
280S-8	37	50	78.0	74	740	91.5	0.79	2.0	6.6	2.8
280M-8	45	60	95.0	90	740	92.0	0.79	2.0	6.6	2.4
315S-8	55	75	115	110	740	92.8	0.81	1.8	6.6	2.4
315M-8	75	100	150	145	740	93.5	0.81	1.8	6.6	2.2
315L1-8	90	125	180	170	740	93.8	0.82	1.8	6.6	2.2
315L2-8	110	150	220	205	740	94.1	0.82	1.9	6.6	2.3
355M1-8	132	180	265	250	740	94.4	0.82	1.9	6.5	2.3
355M2-8	160	215	315	300	740	94.7	0.83	1.9	6.5	2.0
355L-8	200	270	386	367	740	94.8	0.83	1.9	6.5	2.0
同步转速600转/分 (10极) 380V 50Hz Synchronous Speed 600 r/min (10 Poles)										
315S-10	45	60	100	95	590	91.5	0.75	1.5	6.2	2.0
315M-10	55	75	122	115	590	92.0	0.75	1.5	6.2	2.0
315L1-10	75	100	163	155	590	92.5	0.76	1.5	6.2	2.0
315L2-10	90	120	191	182	590	93.0	0.77	1.5	6.2	2.0
355M1-10	110	150	230	218	590	93.2	0.78	1.3	6.0	2.0
355M2-10	132	180	275	261	590	93.5	0.78	1.3	6.0	2.0
355L-10	160	215	333	317	590	93.5	0.78	1.3	6.0	2.0

*所有技术说明均基于380V/50Hz满负荷。 All technical details are based on full-load 380V/50Hz.

*因为各个国家的电压不同，技术数据将会有所改变

BECAUSE THE DIFFERENT VOLTAGE OF EACH COUNTRY, THE TECHNICAL DATA WILL BE CHANGED

www.famcocorp.com

E-mail: info@famcocorp.com

@famco_group

Tel: +91-48-000049

Fax: +91-48-999442

تهران، کیلومتر ۲ بزرگراه لشکری (جاده مخصوص کرج)

روبروی پالایشگاه نفت پارس، پلاک ۱۳

KE 系列高效三相异步电动机 SERIES HIGH-EFFICIENCY THREE-PHASE ASYNCHRONOUS INDUCTION MOTOR

简介 INTRODUCTION:

KE系列铸铁高效电机是我公司在2010年推出的新款电动机，功率等级、安装尺寸与YX3系列完全相同，其测试方法符合IEC60034-2-1:2007的相关规定，效率值达到IEC60034-30:2008中的IE2效率等级，且具有独特的外形设计，更接近欧洲市场的风格，其端盖带有散热筋，使其外形美观，同时增加了散热效果；顶置接线盒可四周旋转（也可按要求做成左置或右置出线盒），方便了用户的不同接线需求；同时因采用特殊的风扇及风路设计，使其具有低振动低噪声的特点。在电磁方面，绝缘材料及绝缘工艺较以前也有了较大的改进，无溶剂绝缘漆以及真空浸漆工艺，使电机具有更优越的绝缘性能，更长的使用寿命。

KE Series cast iron housing high-efficiency electric motor is with update design, the power and dimension are in accordance with YX3 series high efficiency motor, the test method is in term of IEC60034-2-1 standard in 2007, and efficiency meet IE2 standard by IEC60034-30 standard in 2008. It has unique configuration design more close to European market style. The end shield with radiating ribs make the motor appearance look good and improve the function of heat dissipation. The top terminal box could rotate all round. T.B could also be left or right mounted as option to meet different requirements from customers. At the same time, the special fan and wind path designed make low vibration and low noise. In electric magnetic aspect, the insulating material and insulating process are improved greatly, solvent free insulating paint and VPI impregnation technology make the motor more insulating property and long working life.



效三相异步电动机 HIGH-EFFICIENCY HASE ASYNCHRONOUS INDUCTION MOTOR

使用条件 OPERATING CONDITIONS

环境温度: -15℃<θ<40℃

海拔: 不超过1000m

额定电压: 380V 400V (可根据用户需要设计)

额定频率: 50HZ 60HZ (可根据用户需要设计)

防护等级: IP55

冷却方式: IC411

绝缘等级: F

工作方式: S1

Ambient temperature: -15℃<θ<40℃

Altitude: not exceed 1000m

Rated voltage: 380V 400V (At buyer's option)

Rated frequency: 50HZ 60HZ (At buyer's option)

Protection class: IP55

Cooling method: IC411

Insulation class: F

Duty: S1

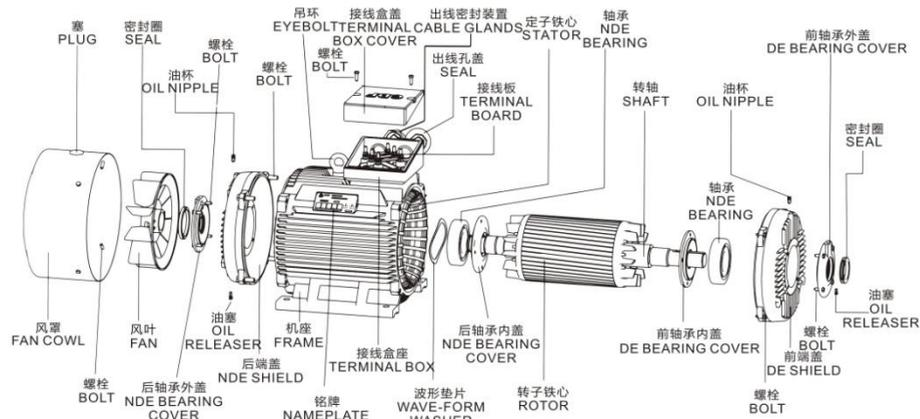

KE 技术数据 TECHNICAL DATA

型号 Model	功率 Output		电流 Current (A)		转速 Speed (r/min)	效率 Eff (%)	功率因素 Power factor	额定转矩 N.m	堵转转矩 Tstart/Tn	堵转电流 Ist/In	最大转矩 Tmax/Tn	噪声 dB (A)
	KW	HP	380V	400V								
同步转速 SYNCHRONOUS SPEED: 3000 r/min IE2 50HZ												
KE80M1-2	0.75	1	0.77	1.68	2865	77.4	0.83	2.50	2.3	6.8	2.3	62
KE80M2-2	1.1	1.5	2.43	2.31	2880	79.6	0.84	3.65	2.3	7.3	2.3	62
KE90S-2	1.5	2	3.19	3.03	2900	81.3	0.84	4.94	2.3	7.6	2.3	67
KE90L-2	2.2	3	4.59	4.36	2890	83.2	0.85	7.27	2.5	7.8	2.3	67
KE100L-2	3	4	6.04	5.74	2890	84.6	0.87	9.91	2.5	8.1	2.3	74
KE112M-2	4	5.5	7.9	7.51	2910	85.8	0.88	13.1	2.5	8.3	2.3	77
KE132M1-2	5.5	7.5	10.7	10.2	2920	87.0	0.88	18.0	2.2	8.0	2.3	79
KE132S2-2	7.5	10	14.5	13.8	2920	88.1	0.89	24.5	2.2	7.8	2.3	79
KE160M1-2	11	15	20.8	19.8	2942	89.4	0.89	35.7	2.2	7.9	2.3	81
KE160M2-2	15	20	28.1	26.7	2942	90.3	0.89	48.7	2.2	8	2.3	81
KE160L-2	18.5	25	34.0	32.3	2942	90.9	0.89	60.1	2.2	8.1	2.3	81
KE180M-2	22	30	40.3	38.3	2960	91.3	0.89	71.0	2.2	8.2	2.3	83
KE200L1-2	30	40	54.5	51.8	2965	92.0	0.89	96.6	2.2	7.5	2.3	84
KE200L2-2	37	50	66.9	63.6	2965	92.5	0.89	119	2.2	7.5	2.3	84
KE225M-2	45	60	81.1	77.0	2965	92.9	0.89	145	2.2	7.6	2.3	86
KE250M-2	55	75	98	93.1	2970	93.2	0.89	177	2.2	7.6	2.3	89
KE280S-2	75	100	132	125	2975	93.8	0.89	241	2.2	6.9	2.3	91
KE280M-2	90	125	158	150	2975	94.1	0.89	289	2.2	7.0	2.3	91
KE315S-2	110	150	194	184	2975	94.3	0.90	353	1.9	7.1	2.2	92
KE315M-2	132	180	231	219	2975	94.6	0.90	424	1.9	7.1	2.2	92
KE315L1-2	160	215	280	266	2975	94.8	0.91	511	1.9	7.1	2.2	92
KE135L2-2	200	270	350	333	2975	95	0.91	642	1.9	7.1	2.2	92
KE355M-2	250	340	433	411	2980	95	0.91	801	1.9	7.1	2.2	100
KE355L-2	315	420	545	518	2980	95	0.91	1009	1.9	7.1	2.2	100
同步转速 SYNCHRONOUS SPEED: 1500 r/min IE2 50HZ												
KE80M1-4	0.55	0.75	1.38	1.31	1435	78.1	0.75	3.66	2.6	6.3	2.3	56
KE80M2-4	0.75	1.0	1.85	1.76	1435	79.6	0.75	4.99	2.6	6.5	2.3	56
KE90S-4	1.1	1.5	2.59	2.46	1435	81.4	0.75	7.32	2.8	6.6	2.3	59
KE90L-4	1.5	2.0	3.48	3.36	1440	82.8	0.75	9.95	2.8	6.9	2.3	59
KE100L1-4	2.2	3.0	4.77	4.53	1450	84.3	0.81	14.5	2.6	7.5	2.3	64
KE100L2-4	3	4.0	6.36	6.04	1450	85.5	0.82	19.8	2.6	7.6	2.3	64
KE112M-4	4	5.5	8.4	7.98	1455	86.6	0.82	26.3	2.6	7.7	2.3	65
KE132S-4	5.5	7.5	11.3	10.7	1460	87.7	0.83	36.0	2.6	7.5	2.3	71
KE132M-4	7.5	10	15.1	14.3	1460	88.7	0.83	49.1	2.6	7.4	2.3	71
KE160M-4	11	15	21.9	20.8	1470	89.8	0.85	71.5	2.6	7.5	2.3	73
KE160L-4	15	20	29.2	27.7	1470	90.6	0.86	97.4	2.6	7.7	2.3	73
KE180M-4	18.5	25	35.4	33.6	1475	91.2	0.86	120	2.2	7.7	2.3	76
KE180L-4	22	30	42.0	39.9	1475	91.6	0.86	142	2.2	7.8	2.3	76
KE200L-4	30	40	56.8	54.0	1475	92.3	0.86	194	2.2	7.2	2.3	76
KE225L-4	37	50	71.6	68.6	1480	92.7	0.86	256	2.2	7.3	2.3	78

KE 系列高效三相异步电动机
KE SERIES HIGH-EFFICIENCY
THREE-PHASE ASYNCHRONOUS INDUCTION MOTOR

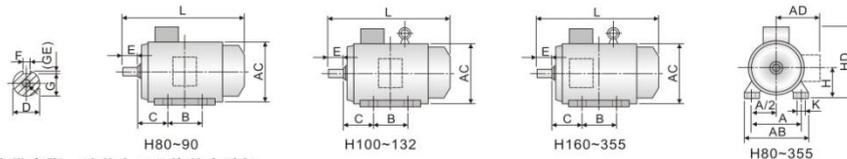

机座带底脚，端盖无凸缘的电动机
FRAME WITH FEET AND ENDSHIELD WITHOUT FLANGE

机座号 Frame size	极数 Poles	安装尺寸 Mounting Dimensions										外形尺寸 Overall dimensions				
		A	B	C	D	E	F	G	H	K	AB	AC	AD	HD	L	
80M	2,4	125	100	50±1.5	19 ^{+0.009} _{-0.004}	40±0.31	6	18.5 ⁰ _{-0.10}	80 ⁰ _{-0.50}	10 ^{+0.360} ₀	165	175	145	220	305	
90S	2,4,6,8	140	100	56±1.5	24 ^{+0.009} _{-0.004}	50±0.31	8	20 ⁰ _{-0.20}	90 ⁰ _{-0.50}	180 ⁰ _{-0.50}	180	195	165	260	360	
90L																
100L	2,4,6,8	160	140	63±2.0	28 ^{+0.009} _{-0.004}	60±0.37	8	24 ⁰ _{-0.20}	100 ⁰ _{-0.50}	12 ^{+0.430} ₀	205	215	180	275	435	
112M																
132S	2,4,6,8	216	140	89±2.0	38 ^{+0.018} _{+0.002}	80±0.37	10	33 ⁰ _{-0.20}	132 ⁰ _{-0.50}	14.5 ^{+0.430} ₀	270	275	210	345	510	
132M																
160M																
160L																
180M																
180L																
200L	4	318	305	133±3.0	55 ^{+0.030} _{+0.011}	110±0.43	14	42.5 ⁰ _{-0.20}	180 ⁰ _{-0.50}	18.5 ^{+0.520} ₀	355	380	280	455	740	
225S																
225M	2	356	311	140±4.0	55 ^{+0.030} _{+0.011}	140±0.50	16	49 ⁰ _{-0.20}	225 ⁰ _{-0.50}	24	395	420	305	505	790	
250M																
250M	2	406	349	168±4.0	60 ^{+0.030} _{+0.011}	140±0.50	18	53 ⁰ _{-0.20}	250 ⁰ _{-0.50}	24	435	470	335	560	830	
280S																
280M	2	457	368	190±4.0	65 ^{+0.030} _{+0.011}	140±0.50	18	58 ⁰ _{-0.20}	280 ⁰ _{-1.0}	28	490	510	370	615	915	
315S																
315M	2	508	457	216±4.0	75 ^{+0.030} _{+0.011}	170±0.50	22	67.5 ⁰ _{-0.20}	315 ⁰ _{-1.0}	28	550	580	410	680	1035	
355M																
355L	2	610	560	254±4.0	75 ^{+0.030} _{+0.011}	140±0.50	20	67.5 ⁰ _{-0.20}	355 ⁰ _{-1.0}	28	730	710	655	1010	1525	
355L																

distance from the flange mounting-plane to the shaft-extension shoulder

型号 Model	功率 Output		电流 Current (A)		转速 Speed (r/min)	效率 Eff (%)	功率因素 Power factor	额定转矩 N.m	堵转转矩 Tstart/Tn	堵转电流 Ist/In	最大转矩 Tmax/Tn	噪声 dB (A)
	KW	HP	380V	400V								
同步转速 SYNCHRONOUS SPEED: 1500 r/min IE2 50HZ												
KE225M-4	45	60	83.7	79.5	1480	93.1	0.86	290	2.2	7.4	2.3	78
KE250M-4	55	75	102	96.9	1480	93.5	0.86	355	2.2	7.4	2.3	79
KE280S-4	75	100	138	131	1485	94	0.88	420	2.2	6.7	2.3	80
KE280M-4	90	125	165	157	1485	94.2	0.88	579	2.2	6.9	2.3	80
KE315S-4	110	150	199	189	1480	94.5	0.88	710	2.2	6.9	2.3	88
KE315M-4	132	180	239	227	1480	94.7	0.88	852	2.2	6.9	2.2	88
KE315L1-4	160	215	290	276	1480	94.9	0.88	1032	2.2	6.9	2.2	88
KE315L2-4	200	270	362	344	1480	95.1	0.88	1291	2.2	6.9	2.2	88
KE355M-4	250	340	442	420	1490	95.1	0.90	1602	2.2	6.9	2.2	95
KE355L-4	315	420	559	531	1490	95.1	0.90	2019	2.2	6.9	2.2	95
同步转速 SYNCHRONOUS SPEED: 1000 r/min IE2 50HZ												
KE90S-6	0.75	1.0	2.04	1.94	950	75.9	0.72	7.54	2.1	5.8	2.1	57
KE90L-6	1.1	1.5	2.87	2.73	950	78.1	0.73	11.1	2.1	5.9	2.1	57
KE100L-6	1.5	2.0	3.73	3.54	950	79.8	0.74	15.1	2.1	6.0	2.1	61
KE112M-6	2.2	3.0	5.30	5.04	955	81.8	0.74	22.0	2.1	6.0	2.1	65
KE132S-6	3	4	7.10	6.75	970	83.3	0.74	29.5	2.3	6.2	2.1	69
KE132M1-6	4	5.5	9.30	8.84	970	84.6	0.74	39.4	2.3	6.8	2.1	69
KE132M2-6	5.5	7.5	12.4	11.8	970	86	0.75	54.1	2.3	7.1	2.1	69
KE160M-6	7.5	10	16.6	15.8	976	87.2	0.78	73.4	2.3	6.7	2.1	70
KE160L-6	11	15	23.8	22.6	976	88.7	0.79	108	2.3	6.9	2.1	70
KE180L-6	15	20	31.0	29.5	980	89.7	0.81	146	2.3	7.2	2.1	73
KE200L1-6	18.5	25	37.9	36.0	980	90.4	0.81	180	2.3	7.2	2.1	73
KE200L2-6	22	30	43.8	41.6	980	90.9	0.82	214	2.3	7.3	2.1	73
KE225M-6	30	40	58.7	55.8	985	91.7	0.81	291	2.2	7.1	2.1	74
KE250M-6	37	50	71.0	67.5	980	92.2	0.84	361	2.2	7.1	2.1	76
KE280S-6	45	60	85.0	80.8	990	92.7	0.86	434	2.2	7.2	2.0	78
KE280M-6	55	75	104	98.8	990	93.1	0.86	531	2.2	7.2	2.0	78
KE315S-6	75	100	141	134	990	93.7	0.85	766	2.0	6.7	2.0	83
KE315M-6	90	125	168	160	990	94	0.84	919	2.0	6.7	2.0	83
KE315L1-6	110	150	205	195	990	94.3	0.85	1123	2.0	6.7	2.0	83
KE315L2-6	132	180	242	230	990	94.6	0.86	1348	2.0	6.7	2.0	83
KE355M1-6	160	215	292	277	990	94.8	0.87	1543	2.0	6.7	2.0	83
KE355M2-6	200	270	365	347	990	95	0.87	1929	2.0	6.7	2.0	85
KE355L-6	250	340	457	434	990	95	0.87	2412	2.0	6.7	2.0	85

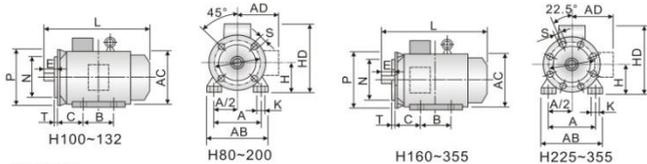

机座带底脚，端盖上有凸缘（带通孔）的电动机 FRAME WITH FEET AND ENDSHIELD WITH FLANGE (WITH THROUGH HOLES)

机座号 Frame size	凸缘号 Flange NO.	极数 Poles	安装尺寸 Mounting Dimension														外形尺寸 Overall Dimension						
			A	B	C	D	E	F	G	H	K	M	N	P	R*	S	T	AB	AC	AD	HD	L	
80M	FF165	2,4,6,8	125	100	50±1.5	19 ^{+0.009} _{-0.004}	40±0.31	6	15.5 ⁰ _{-0.10}	80 ⁰ _{-0.50}	10 ^{+0.360} ₀	165	130	130 ^{+0.014} _{-0.011}	200	0±1.5	12	3.5	165	175	145	220	305
90S			100	125	56±1.5	24	50±0.31	20 ⁰ _{-0.20}	90 ⁰ _{-0.50}	12 ^{+0.430} ₀	215	180	180 ^{+0.014} _{-0.011}	250	0±2.0	14.5	4	180	195	165	260	360	
90L			140	125	56±1.5	24	50±0.31	20 ⁰ _{-0.20}	90 ⁰ _{-0.50}	12 ^{+0.430} ₀	215	180	180 ^{+0.014} _{-0.011}	250	0±2.0	14.5	4	180	195	165	260	390	
100L	FF215	2,4,6,8	160	140	63±2.0	28 ^{+0.009} _{-0.004}	60±0.37	8	24 ⁰ _{-0.20}	100 ⁰ _{-0.50}	12 ^{+0.430} ₀	215	180	180 ^{+0.014} _{-0.011}	250	0±2.0	14.5	4	205	215	180	270	345
112M			190	140	70±2.0	28 ^{+0.009} _{-0.004}	60±0.37	24 ⁰ _{-0.20}	112 ⁰ _{-0.50}	12 ^{+0.430} ₀	215	180	180 ^{+0.014} _{-0.011}	250	0±2.0	14.5	4	230	240	190	300	470	
132S	FF265	2,4,6,8	216	140	89±2.0	38 ^{+0.018} _{-0.002}	80±0.37	10	33 ⁰ _{-0.20}	132 ⁰ _{-0.50}	14.5 ^{+0.430} ₀	300	250	250 ^{+0.016} _{-0.013}	350	0±3.0			270	275	210	345	510
132M			178	140	89±2.0	38 ^{+0.018} _{-0.002}	80±0.37	10	33 ⁰ _{-0.20}	132 ⁰ _{-0.50}	14.5 ^{+0.430} ₀	300	250	250 ^{+0.016} _{-0.013}	350	0±3.0			270	275	210	345	560
160M	FF300	2,4,6,8	254	254	108±3.0	42 ^{+0.018} _{-0.002}	110±0.43	12	37 ⁰ _{-0.20}	160 ⁰ _{-0.50}	14.5 ^{+0.430} ₀	300	250	250 ^{+0.016} _{-0.013}	350	0±3.0			320	330	255	420	670
160L			241	254	108±3.0	42 ^{+0.018} _{-0.002}	110±0.43	12	37 ⁰ _{-0.20}	160 ⁰ _{-0.50}	14.5 ^{+0.430} ₀	300	250	250 ^{+0.016} _{-0.013}	350	0±3.0			320	330	255	420	670
180M			279	279	121±3.0	48 ^{+0.018} _{-0.002}	110±0.43	14	42.5 ⁰ _{-0.20}	180 ⁰ _{-0.50}	14.5 ^{+0.430} ₀	300	250	250 ^{+0.016} _{-0.013}	350	0±3.0			355	380	280	455	740
180L	279	279	121±3.0	48 ^{+0.018} _{-0.002}	110±0.43	14	42.5 ⁰ _{-0.20}	180 ⁰ _{-0.50}	14.5 ^{+0.430} ₀	300	250	250 ^{+0.016} _{-0.013}	350	0±3.0			355	380	280	455	740		
200L	FF350	2,4,6,8	318	305	133±3.0	55 ^{+0.030} _{-0.011}	140±0.40	16	49 ⁰ _{-0.20}	200 ⁰ _{-0.50}	18.5 ^{+0.520} ₀	400	350	350±0.016	400	0±4.0			395	420	305	505	790
225S	FF400	2,4,6,8	286	311	140±4.0	55 ^{+0.030} _{-0.011}	140±0.40	16	49 ⁰ _{-0.20}	225 ⁰ _{-0.50}	18.5 ^{+0.520} ₀	400	350	350±0.018	450	0±4.0			435	470	335	560	830
225M			356	311	140±4.0	55 ^{+0.030} _{-0.011}	140±0.40	16	49 ⁰ _{-0.20}	225 ⁰ _{-0.50}	18.5 ^{+0.520} ₀	400	350	350±0.018	450	0±4.0			435	470	335	560	825
250M	FF500	2,4,6,8	406	349	168±4.0	60 ^{+0.030} _{-0.011}	170±0.50	18	53 ⁰ _{-0.20}	250 ⁰ _{-0.50}	28 ^{+0.520} ₀	500	450	450±0.020	550	0±4.0			490	510	370	615	915
280S			468	368	168±4.0	60 ^{+0.030} _{-0.011}	170±0.50	20	58 ⁰ _{-0.20}	280 ⁰ _{-1.0}	28 ^{+0.520} ₀	500	450	450±0.020	550	0±4.0			490	510	370	615	915
280M			419	368	168±4.0	60 ^{+0.030} _{-0.011}	170±0.50	20	58 ⁰ _{-0.20}	280 ⁰ _{-1.0}	28 ^{+0.520} ₀	500	450	450±0.020	550	0±4.0			490	510	370	615	915
315S	FF600	2,4,6,8	457	457	190±4.0	65 ^{+0.030} _{-0.011}	170±0.50	18	58 ⁰ _{-0.20}	315 ⁰ _{-1.0}	28 ^{+0.520} ₀	600	550	550±0.022	660	0±4.0			550	580	410	680	985
315M			508	457	190±4.0	65 ^{+0.030} _{-0.011}	170±0.50	18	58 ⁰ _{-0.20}	315 ⁰ _{-1.0}	28 ^{+0.520} ₀	600	550	550±0.022	660	0±4.0			550	580	410	680	985
315L	FF740	2,4,6,8	508	508	216±4.0	80 ^{+0.030} _{-0.011}	170±0.50	22	71 ⁰ _{-0.20}	315 ⁰ _{-1.0}	28 ^{+0.520} ₀	600	550	550±0.022	660	0±4.0			635	645	530	845	1200
355M			560	508	216±4.0	80 ^{+0.030} _{-0.011}	170±0.50	22	71 ⁰ _{-0.20}	315 ⁰ _{-1.0}	28 ^{+0.520} ₀	600	550	550±0.022	660	0±4.0			635	645	530	845	1230
355L	FF740	2,4,6,8	610	610	254±4.0	95 ^{+0.035} _{-0.013}	170±0.50	25	86 ⁰ _{-0.20}	355 ⁰ _{-1.0}	28 ^{+0.520} ₀	740	680	680±0.025	800	0±4.0			730	710	655	1010	1525
355M			630	610	254±4.0	95 ^{+0.035} _{-0.013}	170±0.50	25	86 ⁰ _{-0.20}	355 ⁰ _{-1.0}	28 ^{+0.520} ₀	740	680	680±0.025	800	0±4.0			730	710	655	1010	1525
355L			630	610	254±4.0	95 ^{+0.035} _{-0.013}	170±0.50	25	86 ⁰ _{-0.20}	355 ⁰ _{-1.0}	28 ^{+0.520} ₀	740	680	680±0.025	800	0±4.0			730	710	655	1010	1550

KE 系列高效三相异步电动机 KE SERIES HIGH-EFFICIENCY THREE-PHASE ASYNCHRONOUS INDUCTION MOTOR

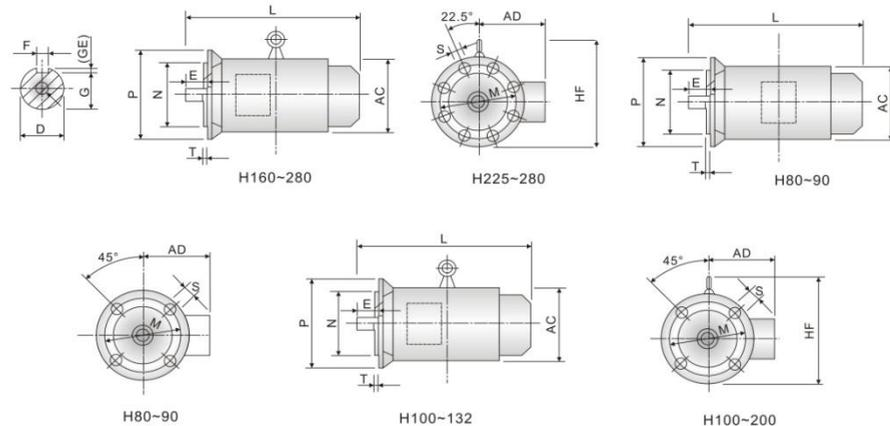

机座不带底脚，端盖上有凸缘（带通孔）的电动机 FRAME WITHOUT FEET AND ENDSHIELD WITH FLANGE (WITH THROUGH HOLES)

机座号 Frame size	凸缘号 Flange NO.	极数 Poles	安装尺寸 Mounting Dimension														外形尺寸 Overall Dimension						
			D	E	F	G	M	N	P	R*	S	T	AC	AD	HF	L							
80M	FF165	2,4,6,8	19 ^{+0.009} _{-0.004}	40±0.31	6	15.5 ⁰ _{-0.10}	165	130	130 ^{+0.014} _{-0.011}	200	0±1.5	12	3.5	175	145	185	305						
90S			24 ^{+0.009} _{-0.004}	50±0.31	8	20 ⁰ _{-0.20}	215	180	180 ^{+0.014} _{-0.011}	250	0±2.0	14.5	4	195	165	195	360						
90L			140	125	56±1.5	24	50±0.31	20 ⁰ _{-0.20}	90 ⁰ _{-0.50}	12 ^{+0.430} ₀	215	180	180 ^{+0.014} _{-0.011}	250	0±2.0	14.5	4	180	195	165	260	390	
100L	FF215	2,4,6,8	28 ^{+0.009} _{-0.004}	60±0.37	8	24 ⁰ _{-0.20}	215	180	180 ^{+0.014} _{-0.011}	250	0±2.0	14.5	4	205	215	180	270	345					
112M			190	140	70±2.0	28 ^{+0.009} _{-0.004}	60±0.37	24 ⁰ _{-0.20}	112 ⁰ _{-0.50}	12 ^{+0.430} ₀	215	180	180 ^{+0.014} _{-0.011}	250	0±2.0	14.5	4	230	240	190	300	470	
132S	FF265	2,4,6,8	38 ^{+0.018} _{-0.002}	80±0.37	10	33 ⁰ _{-0.20}	265	230	230 ^{+0.016} _{-0.013}	300	0±3.0			275	210	315	510						
132M			178	140	89±2.0	38 ^{+0.018} _{-0.002}	80±0.37	10	33 ⁰ _{-0.20}	265	230	230 ^{+0.016} _{-0.013}	300	0±3.0			275	210	315	560			
160M	FF300	2,4,6,8	42 ^{+0.018} _{-0.002}		12	37 ⁰ _{-0.20}	300	250	250 ^{+0.016} _{-0.013}	350	0±3.0			330	255	385	670						
160L			241	254	108±3.0	42 ^{+0.018} _{-0.002}	110±0.43	12	37 ⁰ _{-0.20}	160 ⁰ _{-0.50}	14.5 ^{+0.430} ₀	300	250	250 ^{+0.016} _{-0.013}	350	0±3.0			320	330	255	420	670
180M			279	279	121±3.0	48 ^{+0.018} _{-0.002}	110±0.43	14	42.5 ⁰ _{-0.20}	180 ⁰ _{-0.50}	14.5 ^{+0.430} ₀	300	250	250 ^{+0.016} _{-0.013}	350	0±3.0			355	380	280	455	740
180L	279	279	121±3.0	48 ^{+0.018} _{-0.002}	110±0.43	14	42.5 ⁰ _{-0.20}	180 ⁰ _{-0.50}	14.5 ^{+0.430} ₀	300	250	250 ^{+0.016} _{-0.013}	350	0±3.0			355	380	280	455	740		
200L	FF350	2,4,6,8	55 ^{+0.030} _{-0.011}		16	49 ⁰ _{-0.20}	350	300±0.016	400	0±4.0			420	305	480	790							
225S	FF400	2,4,6,8	60 ^{+0.030} _{-0.011}		18	53 ⁰ _{-0.20}	400	350±0.018	450	0±4.0			435	335	535	830							
225M			356	311	140±4.0	55 ^{+0.030} _{-0.011}	140±0.40	16	49 ⁰ _{-0.20}	400	350±0.018	450	0±4.0			470	335	535	825				
250M	FF500	2,4,6,8	60 ^{+0.030} _{-0.011}		18	53 ⁰ _{-0.20}	500	450±0.020	550	0±4.0			490	370	595	915							
280S			468	368	168±4.0	60 ^{+0.030} _{-0.011}	170±0.50	20	58 ⁰ _{-0.20}	280 ⁰ _{-1.0}	28 ^{+0.520} ₀	500	450	450±0.020	550	0±4.0			490	510	370	615	915
280M			419	368	168±4.0	60 ^{+0.030} _{-0.011}	170±0.50	20	58 ⁰ _{-0.20}	280 ⁰ _{-1.0}	28 ^{+0.520} ₀	500	450	450±0.020	550	0±4.0			490	510	370	615	915
315S	FF600	2,4,6,8	65 ^{+0.030} _{-0.011}		20	67.5 ⁰ _{-0.20}	500	450±0.020	550	0±4.0			550	410	650	985							
315M			508	457	190±4.0	65 ^{+0.030} _{-0.011}	170±0.50	22	71 ⁰ _{-0.20}	315 ⁰ _{-1.0}	28 ^{+0.520} ₀	600	550	550±0.022	660	0±4.0			550	580	410	680	985
315L	FF740	2,4,6,8	65 ^{+0.030} _{-0.011}		22	71 ⁰ _{-0.20}	600	550±0.022	660	0±4.0			635	530	845	1200							
355M			560	508	216±4.0	80 ^{+0.030} _{-0.011}	170±0.50	25	86 ⁰ _{-0.20}	355 ⁰ _{-1.0}	28 ^{+0.520} ₀	740	680	680±0.025	800	0±4.0			730	710	655	1010	1525
355L	FF740	2,4,6,8	95 ^{+0.0}																				

冷却式三相异步电动机。其防护等级为IP55，KE3系列的要求。

KE3

KE3系列电动机适用于连续工作制(S1)、恒转速或一定速度范围内的变频调整应用。

The KE3 series three phase asynchronous motors are totally enclosed fan cooled (TEFC) with IP55 environmental protection, and applicable for general purpose use. These motors are designed and manufactured in accordance with EU IE3 standards.

The KE3 series motor is designed for constant or adjustable speed with continuous operation (S1) over a speed range.



KE3系列电动机技术特征

FEATURES OF KE3 SERIES

1. 机座和接线盒材料: KE系列: 灰铸铁;
2. 标准颜色: RAL5010
3. 2、4、6极电动机达到GB60034-30标准能效等级1级,且能满足IEC60034-30标准中的IE3效率等级。
4. 额定功率: 0.55kW-315kW (50Hz);
5. 优化的紧凑型结构;
6. 标准安装结构类型(符合IEC60034-7标准规定): IMB3, IMB5, IMB35等。
7. 所有的电动机设计防护等级为IP55(IEC60034-5);
8. 电动机可选PTC或PT 100热敏电阻或KTY84-130进行绕组保护;
9. 绝缘系统按155℃(F)温度等级,在额定输出和直接供电时按130℃(B)温度等级使用;
10. 电动机标准冷却方式为自扇冷却(IEC60034-6规定的IC411),可提供独立驱动风扇强制冷却。

1. Frame and connection box material: KE series: grey cast iron,
2. Standard color: RAL5010.
3. Available in 2, 4, 6 pole variants with efficiency grade 1 according to GB60034-30 and efficiency class IE3 according to IEC60034-30.
4. Rated power range: 0.55kW - 315kW at 50 Hz.
5. Optimized compact style construction.
6. Standard mounting construction according to IEC60034-7; IMB3, IMB5, IMB35 and etc.
7. All motors are designed to IP55 degree of protection(IEC60034-5).
8. Winding protections with PTC, PT100 and KTY84-130 as option.
9. Insulation system is designed for temperature class 155℃(F). At rated output with line-fed operation, the motors can be used in temperature class 130℃(B).
10. Self ventilated motors with radiating fans (cooling method IC411 according to IEC 60034-6) as standard, forced air cool with external separately driven fans as option.

系列超高效三相异步电动机

SERIES ULTRA HIGH-EFFICIENCY THREE PHASE ASYNCHRONOUS INDUCTION MOTOR

噪声值

NOISE

噪声值根据DIN EN ISO1680标准在噪声室测得。表面声压级噪声(L_{eq}Y...%Y单位)计算表示单位为dB(A)。声压级噪声的空间平均值是在其测量面上测得的。测量面是距离电动机表面一立方米的地方。声功率级噪声用(LWA)来表示,单位为dB(A)。下面给出噪声值仅适用于电动机在50Hz电源供电下且输出额定功率时的情况,容差为+3dB。当在60Hz电源下输出额定功率时,偏差值大约为+4dB。

The noise levels are measured in accordance with DIN EN ISO 1680 in a dead room. It is specified as the A valued measuring surface sound pressure level L_{eq}(dB(A)). This is the spatial mean value of the sound pressure levels measured on the measuring surface. The measuring surface is a cube 1m away from the motor surface. The sound power level is also specified as LWA in dB(A). The following specified values are only valid for standard output at 50Hz, and the tolerance is +3dB. At 60 Hz with rated output, the values are approximately +4 dB(A) higher.

功率 Output (kW)	同步转速 synchronous speed (r/min)		
	Lp/LWA (dB(A))		
	3000(2级poles)	1500(4级poles)	1000(6级poles)
0.55	-	45/57	44/56
0.75	53/65	45/57	48/60
1.1	63/65	47/59	48/60
1.5	60/72	47/59	52/64
2.2	60/72	55/67	54/66
3	63/74	55/67	56/69
4	63/75	55/67	56/69
5.5	66/79	57/70	56/69
7.5	66/79	57/70	60/73
11	67/80	60/73	60/73
15	67/80	60/73	61/74
18.5	67/80	61/74	65/78
22	69/82	61/74	65/78
30	71/84	63/74	65/79
37	71/84	63/77	65/79
45	74/88	63/77	65/79
55	74/88	64/78	65/79
75	74/88	66/80	66/80
90	76/90	66/80	66/80
110	78/92	69/83	68/82
132	78/92	69/83	68/83
160	81/95	69/83	72/87
200	81/95	74/88	75/90
220	86/101	82/97	75/90
250	86/101	82/97	-
280	88/103	85/100	-
315	88/103	85/100	-

振动 VIBRATION

所有电动机转子都使用半键按照A级（标准）振动等级进行动态平衡。电动机在空载时测得振动速度有效值不超过下表中的A级所列值。
KE3 rotors are dynamically balanced to severity grade A using a halfkey. Table below contains the effective vibration values for unloaded motors.

振动等级 Vibration grade	机座号 Frame size (mm)	56 ≤ FS ≤ 132	160 ≤ FS ≤ 280	280 ≤ FS ≤ 355
A	安装方式 Mounting	振动速度 Vibration velocity (mm/s)	振动速度 Vibration velocity (mm/s)	振动速度 Vibration velocity (mm/s)
	自由悬挂 Free suspension	1.6	2.2	2.8
	刚性安装 Rigid mounting	1.3	1.8	2.3

电气特性 ELECTRICAL CHARACTERISTIC 额定输出 RATED OUTPUT

KE3电动机的额定输出是指电动机在连续运行的情况下S1(IEC60034-1)，此时周围环境温度为-20℃~40℃，海拔高度不超过1000m。
KE3 motors rated output power means that the motor runs under continuous duty S1 (IEC60034-1) operation when operated at ambient temperature from -20℃ to 40℃ and at altitudes of up to 1000m oversea.

电压、频率 VOLTAGE AND FREQUENCY

IEC60034-1将电压和频率的偏差分为A类（电压偏差±5%，频率偏差±2%）和B类（电压偏差±10%，频率偏差+3%/-5%）。电动机均能够在A类和B类提供额定转矩。在A类中，温度比正常运行下温度大约提示10K。

IEC60034-1 differentiates between Category A (combination of voltage deviation ±5% and frequency deviation ±2%) and Category B (combination of voltage deviation ±10% and frequency deviation +3%/-5%) for voltage and frequency fluctuations. The motor can supply their rated torque in both category A and B. In Category A, the temperature rise is approximately 10K higher than during normal operation.

标准 Standard 60034-1	类别 Category A	类别 Category B
电压偏差 Voltage deviation	±5%	±10%
频率偏差 Frequency deviation	±2%	+3%/-5%
根据标准：不推荐电动机在B类情况下长时间运行According to the standard, longer operation is not recommended for Category B.		

电气数据公差 TOLERANCE FOR ELECTRICAL DATA

- 效率 η
Prate ≤ 150kW: 0.15* (1- η)
Prate > 150kW: -0.10* (1- η)
效率为小于1的值
- 功率因数: (1-cos ϕ)/6
最小绝对值: 0.02
最大绝对值: 0.07
- 转差率: ±20% (电动机的偏差<1kW ±30%时是允许的)
- 堵转电流: +20%
- 堵转转矩: -15%~+20%
- 最大转矩: -10%
- 转动惯量: 10%

- Efficiency η at
Prate ≤ 150kW: 0.15* (1- η)
Prate > 150kW: 0.10* (1- η)
With η being a decimal number
- Power factor: (1-cos ϕ)/6
Minimum absolute value: 0.02
Maximum absolute value: 0.07
- Slip ±20% (for motors <1kW ±30% is admissible)
- Locked-rotor current: +20%
- Locked-rotor torque: -15%~+25%
- Break down torque: -10%
- Rotational inertia: www.famcocorp.com

Tel: +91-480-000049
E-mail: info@famcocorp.com
@famco_group

KE3 系列超高效三相异步电动机 KE3 SERIES ULTRA HIGH-EFFICIENCY THREE PHASE ASYNCHRONOUS INDUCTION MOTOR

IE3-2级铸铁电机性能参数 PERFORMANCE DATA OF CAST IRON HOUSING IE3-2P MOTORS

型号 Model	功率 Output		电流 Current(A)			转速 Speed (r/min)	效率 Eff (%)	功率因素 Power factor	堵转转矩 Ts/Tn	堵转电流 Is/In	最大转矩 Tm/Tn	重量 Weight (kgs)
	KW	HP	380V	400V	415V							
同步转速 Synchronous Speed 3000r/min IE3 50Hz												
KE3-801-2	0.75	1	1.69	1.61	1.56	2900	80.7	0.83	2.4	7	2.5	20
KE3-802-2	1.1	1.5	2.4	2.28	2.22	2900	82.7	0.84	2.5	7	2.8	23
KE3-90S-2	1.5	2	3.2	3.1	2.98	2840	84.2	0.84	2.7	7	2.8	29
KE3-90L-2	2.2	3	4.6	4.3	4.19	2840	85.9	0.85	2.5	6	2.8	33
KE3-100L-2	3	4	6	5.7	5.44	2870	87.1	0.87	2.2	7.5	2.5	42
KE3-112M-2	4	5.5	7.9	7.5	7.17	2880	88.1	0.88	2.3	7.1	2.3	53
KE3-132S1-2	5.5	7.5	10.7	10.1	9.75	2900	89.2	0.88	2.3	7.5	2.5	66
KE3-132S2-2	7.5	10	14.3	13.5	13.2	2900	90.1	0.89	2.2	7.5	2.4	72
KE3-160M1-2	11	15	20.6	19.6	18.6	2930	91.2	0.89	2.3	7.7	3.1	123
KE3-160M2-2	15	20	27.6	26.3	24.9	2930	91.9	0.9	2.4	7.6	3.1	132
KE3-160L-2	18.5	25	34	32.4	31.3	2930	92.4	0.9	2.7	7.7	3.2	151
KE3-180M-2	22	30	40.2	38.2	36.7	2940	92.7	0.9	2	7.7	2.7	203
KE3-200L1-2	30	40	54.5	51.7	50.2	2950	93.3	0.9	2.1	6.9	2.8	246
KE3-200L2-2	37	50	66.8	63.5	60.3	2950	93.7	0.9	2.2	7	2.6	256
KE3-225M-2	45	60	81	76.9	75.5	2960	94	0.9	2.4	7.3	3.1	328
KE3-250M-2	55	75	97.5	92.6	91.2	2970	94.3	0.91	2.6	7.6	3.1	433
KE3-280S-2	75	100	131	127	122	2960	94.7	0.92	2.2	7.8	2.5	572
KE3-280M-2	90	125	156	153	148	2960	95	0.92	2.2	7.8	2.5	632
KE3-315S-2	110	150	193	185	179	2980	95.2	0.91	1.8	7.1	2.4	950
KE3-315M-2	132	180	231	222	215	2980	95.4	0.91	1.8	7.1	2.4	1020
KE3-315L1-2	160	220	277	267	259	2980	95.6	0.92	1.8	7.1	2.5	1200
KE3-315L2-2	200	270	346	331	319	2980	95.8	0.92	1.8	7.1	2.5	1180
KE3-355M-2	250	340	432	411	395	2980	95.8	0.92	1.6	7.3	2.2	1970
KE3-355L-2	315	430	544	516	497	2980	95.8	0.92	1.6	7.3	2.2	2356

تهران، کیلوستر ۲۱ بزرگراه لشکری (جاده مخصوص کرج)
روبروی پالایشگاه نفت پارس، پلاک ۱۳

Tel: +91-480-000049
Fax: +91-480-4494642

PERFORMANCE DATA OF CAST IRON HOUSING IE3-4P MOTORS

型号 Model	功率 Output		电流 Current(A)			转速 Speed (r/min)	效率 Eff (%)	功率因素 Power factor	堵转转矩 Ts/Tn	堵转电流 Is/In	最大转矩 Tm/Tn	重量 Weight (kgs)
	KW	HP	380V	400V	415V							
同步转速 Synchronous Speed 1500r/min IE3 50Hz												
KE3-802-4	0.75	1	1.8	1.77	1.7	1440	82.5	0.77	2.5	5.3	2.5	29
KE3-90S-4	1.1	1.5	2.6	2.5	2.4	1440	84.1	0.77	2.5	4.7	2.3	44
KE3-90L-4	1.5	2	3.4	3.2	3.1	1440	85.3	0.79	2.2	5.2	2.6	44
KE3-100L1-4	2.2	3	4.8	4.68	4.5	1430	86.7	0.81	2.3	6.8	2.5	46
KE3-100L2-4	3	4	6.6	6.3	6	1430	87.7	0.82	2.3	7.1	2.5	57
KE3-112M-4	4	5.5	8.4	8.2	8	1435	88.6	0.82	2.3	6.4	2.6	68
KE3-132S-4	5.5	7.5	10.9	10.6	10.3	1440	89.6	0.86	2.3	7	2.5	80
KE3-132M-4	7.5	10	15	14.6	14.3	1440	90.4	0.84	2.3	7	2.5	123
KE3-160M-4	11	15	21.6	21.2	20.5	1460	91.4	0.85	2.4	7	2.9	153
KE3-160L-4	15	20	28.5	27.6	26.8	1460	92.1	0.87	2.6	7.6	2.9	204
KE3-180M-4	18.5	25	36.6	34.4	32.9	1470	92.6	0.88	2.2	7	3	215
KE3-180L-4	22	30	41	40.2	38.9	1470	93	0.88	2.2	7	2.7	243
KE3-200L-4	30	40	56.6	53.7	50.9	1470	93.6	0.91	2.2	7.2	3	305
KE3-225S-4	37	50	68.1	66.1	64.7	1475	93.9	0.88	2.2	6.9	2.8	328
KE3-225M-4	45	60	91.7	79.6	77.6	1475	94.2	0.89	2.2	7	3	452
KE3-250M-4	55	75	99.4	96.4	94.4	1480	94.6	0.89	2.2	7.4	2.8	592
KE3-280S-4	75	100	135	131	128	1475	95	0.89	2.2	7.5	2.4	672
KE3-280M-4	90	125	161	157	153	1475	95.2	0.89	2.2	7.5	2.4	980
KE3-315S-4	110	150	197	189	183	1490	95.4	0.89	2.2	6.9	2.7	1040
KE3-315M-4	132	180	235	227	224	1490	95.6	0.89	2.2	6.9	2.6	1190
KE3-315L1-4	160	220	285	273	265	1490	95.8	0.89	2.2	6.9	2.4	1260
KE3-315L2-4	200	270	353	342	335	1490	96	0.9	2.2	6.9	2.4	1810
KE3-355M-4	250	340	451	428	428	1485	96	0.88	2.3	6.8	2.3	1950
KE3-355L-4	315	430	561	538	533	1485	96	0.89	2.3	6.8	2.3	2600

KE3 系列超高效三相异步电动机
KE3 SERIES ULTRA HIGH-EFFICIENCY
THREE PHASE ASYNCHRONOUS INDUCTION MOTOR

IE3-6级铸铁电机性能参数
PERFORMANCE DATA OF CAST IRON HOUSING IE3-6P MOTORS

型号 Model	功率 Output		电流 Current(A)			转速 Speed (r/min)	效率 Eff (%)	功率因素 Power factor	堵转转矩 Ts/Tn	堵转电流 Is/In	最大转矩 Tm/Tn	重量 Weight (kgs)
	KW	HP	380V	400V	415V							
同步转速 Synchronous Speed 1000r/min IE3 50Hz												
KE3-90S-6	0.75	1	2.36	2.24	2.16	910	78.9	0.72	2	5.5	2.2	27
KE3-90L-6	1.1	1.5	2.9	2.8	2.7	910	81	0.73	2	5.5	2.2	30
KE3-100L-6	1.5	2	4	3.8	3.5	940	82.5	0.75	2.1	6.2	2.2	39
KE3-112M-6	2.2	3	5.3	5	4.7	940	84.3	0.76	2.2	5	2.2	54
KE3-132S-6	3	4	7.5	7.1	6.7	960	85.6	0.76	2.2	6.3	2.8	70
KE3-132M1-6	4	5.5	9.9	9.4	8.8	960	86.8	0.76	2.4	6.4	2.9	80
KE3-132M2-6	5.5	7.5	12.4	11.8	11.5	960	88	0.77	2.4	6.5	2.8	92
KE3-160M-6	7.5	10	16.7	15.9	15.2	970	89.1	0.77	2	6.5	2.3	123
KE3-160L-6	11	15	23.8	22.6	21.6	970	90.3	0.78	2	6.5	2.3	157
KE3-180L-6	15	20	31	29.4	28.4	970	91.2	0.81	2.1	7	2.2	206
KE3-200L1-6	18.5	25	37.9	36	34.5	970	91.7	0.81	2.1	6.5	2.8	243
KE3-200L2-6	22	30	43.8	41.6	40	970	92.2	0.83	2.1	6.5	2.7	256
KE3-225M-6	30	40	57.1	55	54.3	980	92.9	0.86	2.1	6.9	2.5	306
KE3-250M-6	37	50	70.1	68.2	66.6	980	93.3	0.86	2.3	6.9	2.3	416
KE3-280S-6	45	60	84.8	81	78.5	980	93.7	0.86	2.3	7	2.7	603
KE3-280M-6	55	75	103.5	98.3	95.6	980	94.1	0.86	2.3	7	2.7	693
KE3-315S-6	75	100	139	135	130	990	94.6	0.88	2	7	2.4	970
KE3-315M-6	90	125	164	161	156	990	94.9	0.88	2	7	2.4	1050
KE3-315L1-6	110	150	199	194	190	990	95.1	0.88	2.1	7	2.4	1100
KE3-315L2-6	132	180	241	232	229	990	95.4	0.87	2.1	7	2.3	1250
KE3-355M1-6	160	220	289	281	274	990	95.6	0.88	2	7	2	1600
KE3-355M2-6	200	270	360	345	335	990	95.8	0.88	2	7	2	1650
KE3-355L-6	250	340	452	429	413	990	95.8	0.88	2.3	7	2.5	1800

车床、水泵，对只有单相电源的家庭、作坊尤，使用优质材料制造，具有外形美观、性能先标准的有关规定。

YC系列电动机为全封闭扇冷式，输出功率3HP及以下采用电容启动，在额定电压下50Hz时启动转矩大于3倍，60Hz时大于2.75倍。输出功率4HP及以上采用电容启动、运转，集中了启动转矩大、运转平稳、温升低、噪声小、过载能力强等优点。

YCL工业系列大马力单相电容启动运转异步电动机，适用于驱动小型车床、水泵，对只有单相电源的家庭作坊尤为适用。该系列电动机采用先进技术设计，使用优质材料制造，具有外形美观、性能先进、维护方便、运行可靠、温升低、噪声小、启动电流小、启动转矩大等特点，符合IEC标准有关规定。

YCL系列电机的外形与YC电机相同，与YC系列电机同功率相比，YCL系列电机的温升平均降低8.74K，效率增加4.21%，功率因数增加0.16。

YC series heavy-duty single-phase motors are suitable for small size machine tools and water pumps, especially suitable for family workshops where only single-phase power be supplied. These series motors are designed with the latest technology, manufactured with the quality materials, have following features: good performance, safe and reliable operation, nice appearance, convenient maintenance, meet the IEC standards.

YC series motors are of IP44 totally enclosed fan-cooled (TEFC) type, capacitor starting for rated output up to 3HP, on rated voltage and 50Hz, the starting torque is three times more than the rated torque, while 60Hz is 2.75 times more. Capacitors start and run type for motors 4HP and above. It has following features: high starting torque, smooth running, low temperature rise, low noise and greater overload performance. YCL series heavy-duty capacitor start and run, single phase induction motors are suitable for driving small-size turning machine, especially suitable for household and workshop where only single-phase power be supplied. This series of motors are designed with advanced technique and made of high quality materials. It also has following features: low noise, low temperature rise, small starting current, high starting torque, reliable operation, easy maintenance and nice appearance, they also meet the relative standards of IEC. YCL series motors are similar to YC series in appearance. Comparing with the same output of YC series motors, YCL series temperature rise is reduced 8.74k on average, efficiency is increased 4.21%, power factor is increased 0.16.

使用条件 OPERATING CONDITIONS

环境温度: $-15^{\circ}\text{C} < \theta < 40^{\circ}\text{C}$ 海拔: 不超过1000M
 额定电压: 110V, 115V, 120V, 220V, 230V, 240V
 额定频率: 50Hz或60Hz 防护等级: IP44, IP54
 绝缘等级: B级, F级, H级 冷却方式: IC411
 工作方式: S1 (连续工作制)
 Ambient temperature: $-15^{\circ}\text{C} < \theta < 40^{\circ}\text{C}$ Altitude: not exceed 1000m
 Rated voltage: 110V, 115V, 120V, 220V, 230V, 240V
 Rated frequency: 50Hz or 60Hz Protection class: IP44, IP54
 Insulation class: B, F, H Cooling method: IC 411
 Duty: S1 (continuous)

MATERIAL TABLE

Item	Description
1	键 Key
2	波形垫圈 Wave-form washer
3	滚珠轴承 Ball bearing
4	转子 Rotor
5	前端盖 DE shield
6	定子 Stator pack with winding
7	机座 Frame
8	接线盒 Terminal box
9	铭牌 Nameplate
10	电容 Capacitor
11	线圈 Winding
12	后端盖 NDE shield
13	离心开关 Centrifugal switch
14	风扇 Fan
15	挡圈 Circlip
16	风罩 Fan cowl

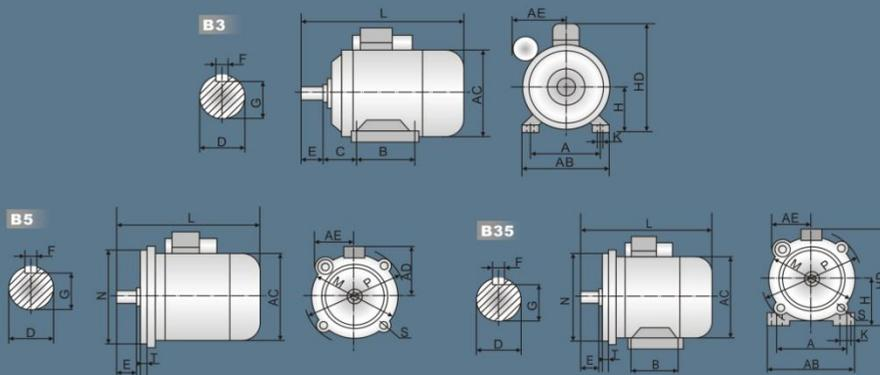
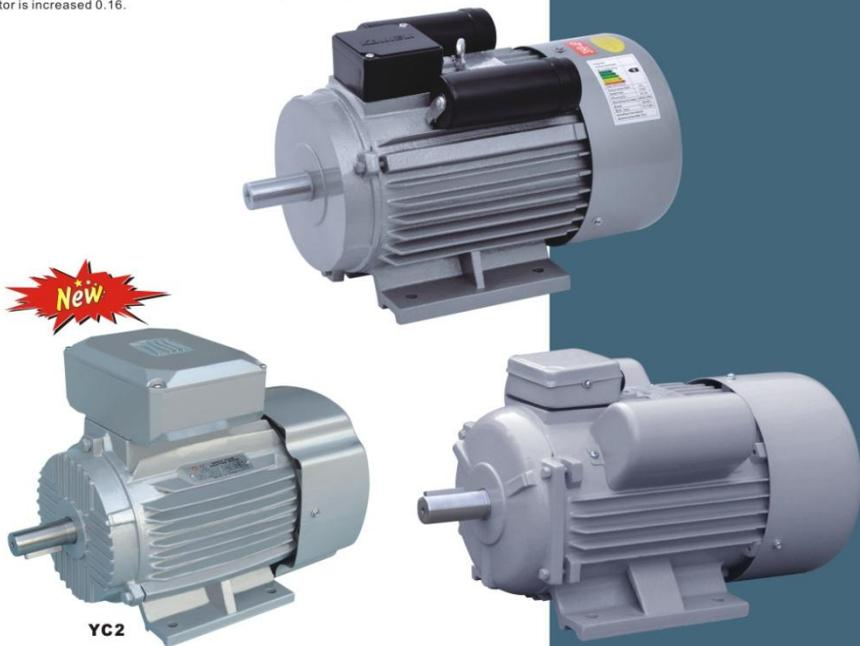
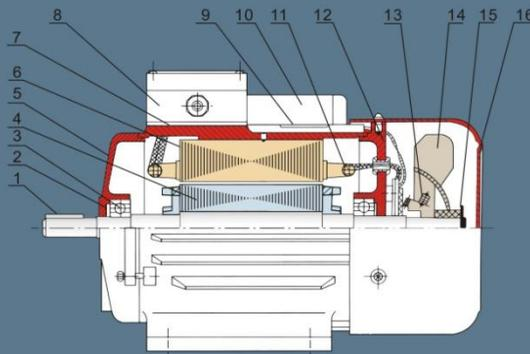

D MOUNTING DIMENSION

安装尺寸 Mounting Dimension (mm)										外形尺寸 Overall Dimension (mm)					
E	F	G	H	K	M	N	P	R	S	AB	AC	AD	HD	L	
30	5	11	71	7	130	110	160	0	10	3.5	145	145	140	255	
40	6	15.5	80	10	165	130	200	0	12	3.5	160	165	150	295	
50	8	20	90	10	165	130	200	0	12	3.5	180	185	160	240	
60	8	20	90	10	165	130	200	0	12	3.5	180	185	160	240	
80	10	28	112	12	215	180	250	0	15	4.0	205	220	180	260	
100	140	70	28	60	8	24	100	12	215	180	250	0	15	4.0	
112M	190	140	80	28	60	8	24	112	12	215	180	250	0	15	4.0
132S	216	140	89	38	80	10	33	132	12	265	230	300	0	15	4.0
132M	216	178	89	38	80	10	33	132	12	265	230	300	0	15	4.0

技术数据 TECHNICAL DATA(220V 50Hz)

型号 Model	功率 Output		电流 Current (A)	功率因素 Power Factor	效率 Eff (%)	转速 Speed (r/min)	堵转转矩 额定转矩 Tstart/Tn	堵转电流 额定电流 Ist/In	最大转矩 额定转矩 Tmax/Tn
	kW	HP							
YC711-2	0.18	1/4	1.9	0.70	63.0	2800	3.0	6.5	2.0
YC712-2	0.25	1/3	2.4	0.72	65.0	2800	3.0	6.5	2.0
YC80A-2	0.37	1/2	3.5	0.74	66.0	2840	3.0	6.5	2.0
YC80B-2	0.55	3/4	5.04	0.74	67.0	2850	3.0	6.5	2.0
YC80C-2	0.75	1	6.68	0.75	68.0	2850	3.0	6.5	2.0
YC90S-2	1.1	1.5	8.93	0.80	70.0	2850	2.8	7.0	2.0
YC90L-2	1.5	2	11.4	0.82	73.0	2870	2.8	7.0	2.0
YC100L-2	2.2	3	16.5	0.82	74.0	2900	2.5	7.0	2.0
YC112M1-2	3	4	21.4	0.84	76.0	2900	2.2	7.0	2.0
YC112M2-2	3.7	5	24.8	0.86	79.0	2900	2.2	7.0	2.0
YC711-4	0.12	1/6	1.9	0.58	18.0	1400	3.0	6.0	2.0
YC712-4	0.18	1/4	2.7	0.60	50.0	1400	3.0	6.0	2.0
YC80A-4	0.25	1/3	3.52	0.62	52.0	1400	3.0	6.0	2.0
YC80B-4	0.37	1/2	4.69	0.64	56.0	1400	3.0	6.0	2.0
YC80C-4	0.55	3/4	6.0	0.65	60.0	1400	3.0	6.0	2.0
YC90S-4	0.75	1	7.5	0.72	63.0	1400	2.8	6.5	2.0
YC90L-4	1.1	1.5	10.4	0.72	67.0	1420	2.8	6.5	2.0
YC100L-4	1.5	2	13.0	0.73	72.0	1440	2.8	6.5	2.0
YC112M-4	2.2	3	18.5	0.74	73.0	1450	2.5	6.5	2.0
YC132S1-4	3	4	22.4	0.80	76.0	1450	2.2	6.5	2.0
YC132S2-4	3.7	5	26.0	0.82	79.0	1450	2.2	6.5	2.0

技术数据 TECHNICAL DATA(220V 50Hz)

型号 Model	功率 Output		电流 Current (A)	功率因素 Power Factor	效率 Eff (%)	转速 Speed (r/min)	堵转转矩 额定转矩 Tstart/Tn	堵转电流 额定电流 Ist/In	最大转矩 额定转矩 Tmax/Tn
	kW	HP							
YCL90S-2	1.1	1.5	7.2	0.95	73.2	2880	2.8	6.0	1.8
YCL90L-2	1.5	2	8.9	0.97	76.0	2900	2.8	7.0	1.8
YCL100L-2	2.2	3	13.2	0.96	78.8	2900	3.0	6.5	1.8
YCL90S-4	0.75	1	5.0	0.93	73.3	1450	2.8	6.5	1.8
YCL90L-4	1.1	1.5	7.8	0.90	75.0	1450	2.5	6.0	1.8
YCL100L-4	1.5	2	9.3	0.92	79.4	1450	2.8	7.0	1.8
YCL112M-4	2.2	3	13.6	0.90	81.6	1450	2.3	6.5	1.8
YCL132S1-4	3.0	4	18.2	0.90	83.5	1450	2.1	6.5	1.8
YCL132S2-4	3.7	5	22.0	0.90	84.9	1450	2.1	6.5	1.8
YCL132M1-4	5.5	7.5	32.5	0.90	85.0	1460	2.0	6.5	1.8
YCL132M2-4	7.5	10	40.0	0.90	85.5	1460	2.0	6.5	1.8

*因为各个国家的电压不同，技术数据将会有所改变。
*BECAUSE THE DIFFERENT VOLTAGE OF EACH COUNTRY, THE TECHNICAL DATA WILL BE CHANGED.

Y2 中型低压大功率三相异步电动机 SERIES MEDIUM-SIZED LOW-VOLTAGE THREE-PHASE ASYNCHRONOUS MOTORS

Y2 中型低压大功率电动机外形图及安装尺寸
Y2 SERIES OVERALL AND MOUNTING DIMENSION

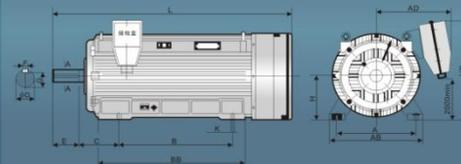

机座 Frame Size	极数 Pole	安装尺寸及公差 Mounting Dimension And Tolerance												外形尺寸(限值) Overall Dimension										
		A		B		C		D		E		F		G		H		K		AD	HD	AB	BB	L
		基本 尺寸 Size	极限 偏差 Tolerance	基本 尺寸 Size	极限 偏差 Tolerance	基本 尺寸 Size	极限 偏差 Tolerance	基本 尺寸 Size	极限 偏差 Tolerance	基本 尺寸 Size	极限 偏差 Tolerance	基本 尺寸 Size	极限 偏差 Tolerance	基本 尺寸 Size	极限 偏差 Tolerance	基本 尺寸 Size	极限 偏差 Tolerance	基本 尺寸 Size	极限 偏差 Tolerance					
355	2	630	+1.4 -1.4	900	+1.4 -1.4	254		75		140	+0.50 -0.50	20		67.2		355		28	+0.52 0	1165	1390	750	1160	2000
	4-6							100		210	+0.57 -0.57	28		90										
400	2	710		1000			+4.0 -4.0	52	+0.035 -0.013	170	+0.50 -0.50	22	0	76		400	0			1250	1465	850	1270	2200
	4-8					280		110		210	+0.57 -0.57	28	-0.052	100	-0.20		-1.0							
450	2	800	+1.75 -1.75	1120	+1.75 -1.75			95		170	+0.50 -0.50	25		86		450		35	+0.62 0	1315	1100	950	1400	2300
	6-8							120	+0.040 -0.015	210		32	0	109										

Y2 中型低压大功率电动机技术数据 (额定功率kW) Y2 SERIES MEDIUM-SIZED LOW-VOLTAGE THREE-PHASE ASYNCHRONOUS MOTORS TECHNICAL DATA RATED OUTPUT (KW)

机座 Frame Size	电动机同步转速 Synchronous Speed(r/min)					
	3000	1500	1000	750	600	500
355	355	355	280	220	160	110
	400	400	315	250	180	132
	450	450	355	280	200	160
	500	500	400	315	220	180
400	560	560	450	355	250	200
	630*	630	500	400	280	220
450	710*	710*	560	450	315	250
	800*	800*	630	500	355	280
	900*	900*	710	560	400	315

注: 1.其中代*的规格为660V, 其余为380V。
2.以上为我公司通用型, 若有需要, 也可根据客户要求设计专用型。
Note: 1.Data with * are for rated voltage 660V, the others for rated voltage 380V.
2.Data in the table are for universal type, the specific type can be designed if request.

(380V 50Hz)

输出 (kW)	电流 Current (A)	效率 Eff (%)	功率因素 Power Factor	堵转电流 额定电流 Is/I _n	堵转转矩 额定转矩 T _{st} /T _n	最大转矩 额定转矩 T _{max} /T _n			
7	15.2	84	0.89	6.5	1.5	1.8			
8	19.0	85	0.66	5.5	1.5	1.8			
4	14.50	11	21.8	86	0.89	6.5	1.5	1.8	
8	730	11	26.0	86	0.74	6	1.5	1.8	
4	1470	17	31.5	87	0.92	7	1.5	1.8	
8	740	14	33.0	86	0.74	6	1.5	1.8	
4	1470	22	44.3	88	0.92	7	1.5	1.8	
8	740	17	40.1	87	0.74	6	1.5	1.8	
4	1470	25	48.8	88	0.92	7	1.5	1.8	
8	740	24	53.2	89	0.77	6	1.4	1.8	
4	1470	34	66.7	88	0.88	7	1.3	1.8	
8	740	30	64.9	90	0.78	6	1.4	1.8	
4	1480	42	78.8	89	0.91	7	1.3	1.8	
8	740	40	83.5	91	0.80	6	1.4	1.8	
4	1480	55	102	90	0.91	7	1.3	1.8	
8	740	47	96.9	91	0.81	6	1.4	1.8	
4	1480	67	122.9	90	0.92	7	1.3	1.8	
8	680	0.35	1.6	56	0.60	5	1.5	1.8	
6	930	0.45	1.4	70	0.72	6	1.5	1.8	
8	680	0.45	1.9	59	0.60	5	1.5	1.8	
6	930	0.65	1.9	71	0.73	6	1.5	1.8	
8	710	0.75	2.9	65	0.60	5	1.5	1.8	
6	950	1.1	3.1	75	0.73	6	1.5	1.8	
8	710	1.3	4.5	72	0.61	5	1.5	1.8	
6	950	1.8	4.8	78	0.73	6	1.5	1.8	
8	730	1.8	5.8	75	0.62	5	1.5	1.8	
6	970	2.4	6.2	80	0.73	6	1.5	1.8	
8	730	2.6	8.2	78	0.62	5	1.5	1.8	
6	970	3.7	9.4	82	0.73	6	1.5	1.8	
8	930	4.5	13.3	83	0.62	5	1.5	1.8	
6	980	6	14.7	85	0.73	6	1.5	1.8	
8	930	6	17.5	84	0.62	5	1.5	1.8	
6	980	8	19.4	86	0.73	6	1.5	1.8	
8	930	7.5	21.9	84	0.62	5	1.5	1.8	
6	980	10	24.2	86	0.73	6	1.5	1.8	
8	730	9	24.8	85	0.68	5	1.5	1.8	
6	980	12	28.3	86	0.75	6	1.5	1.8	
8	730	12	32.5	86	0.65	5	1.5	1.8	
6	980	17	39.1	87	0.76	6	1.5	1.8	
8	730	15	40.3	87	0.65	5	1.5	1.8	
6	980	20	45.4	88	0.76	6	1.5	1.8	
YD100L	6/4/2	940/1420/2880	0.75/1.3/1.8	2.62/3.66/4.53	67/72/71	0.65/0.75/0.85	5.5/6/7	1.8/1.6/1.6	1.8/1.8/1.8
YD112M	6/4/2	940/1440/2890	1.1/2.2/4	3.52/5.14/5.80	73/74/74	0.65/0.81/0.85	5.5/6/7	1.7/1.4/1.6	1.8/1.8/1.8
YD132S	6/4/2	940/1440/2900	1.8/2.6/3	5.14/6.10/7.38	75/78/71	0.71/0.83/0.87	5.5/6/7	1.4/1.3/1.7	1.8/1.8/1.8
YD132M1	6/4/2	940/1440/2900	2.2/3.3/4	6.03/7.46/8.79	77/80/76	0.72/0.84/0.91	5.5/6/7	1.3/1.3/1.7	1.8/1.8/1.8
YD132M2	6/4/2	940/1440/2900	2.6/4/5	6.86/9.04/10.8	80/80/77	0.72/0.84/0.91	5.5/6/7	1.5/1.4/1.7	1.8/1.8/1.8
YD160M	6/4/2	970/1490/2930	3.7/5/6	9.52/11.2/13.2	81/81/76	0.72/0.84/0.91	5.5/6/7	1.5/1.3/1.4	1.8/1.8/1.8
YD160L	6/4/2	910/1460/2930	4.5/7/9	11.4/15.1/18.8	83/83/79	0.72/0.85/0.92	5.5/6/7	1.5/1.2/1.3	1.8/1.8/1.8
YD112M	8/4/2	710/1440/2900	0.65/2/2.4	2.66/5.14/5.80	59/74/74	0.63/0.81/0.85	4.5/6/7	1.4/1.3/1.2	1.8/1.8/1.8
YD132S	8/4/2	710/1440/2900	1.2/6/3	3.16/6.10/7.05	69/78/74	0.61/0.83/0.87	4.5/6/7	1.4/1.2/1.4	1.8/1.8/1.8
YD132M	8/4/2	710/1440/2900	1.3/3.7/4.5	4.56/8.37/10.0	71/80/75	0.61/0.84/0.91	4.5/6/7	1.5/1.3/1.4	1.8/1.8/1.8
YD160M	8/4/2	720/1460/2930	2.2/5/6	7.55/11.2/13.2	75/81/76	0.59/0.84/0.91	4.5/6/7	1.4/1.3/1.4	1.8/1.8/1.8
YD160L	8/4/2	720/1460/2930	2.8/7/9	9.21/15.10/18.80	77/83/79	0.60/0.85/0.92	5.5/6/7	1.3/1.2/1.3	1.8/1.8/1.8
YD112M	8/6/4	710/940/1400	0.85/1/1.5	3.72/3.06/3.53	62/68/75	0.56/0.73/0.86	5.5/6/7	1.4/1.2/1.4	1.8/1.8/1.8
YD132S	8/6/4	710/940/1440	1.1/1.5/1.8	4.10/4.22/4.03	68/74/78	0.60/0.73/0.87	5.5/6/7	1.4/1.3/1.3	1.8/1.8/1.8
YD132M1	8/6/4	710/940/1440	1.5/2/2.2	5.18/5.41/4.87	71/77/79	0.62/0.73/0.87	5.5/6/7	1.3/1.5/1.4	1.8/1.8/1.8
YD132M2	8/6/4	710/940/1440	1.8/2/6/3	6.13/6.84/6.55	72/78/80	0.62/0.74/0.87	5.5/6/7	1.5/1.5/1.5	1.8/1.8/1.8
YD160M	8/6/4	720/970/1460	3.3/4/5.5	10.29/8.7/11.6	79/81/83	0.62/0.76/0.87	5.5/6/7	1.7/1.4/1.5	1.8/1.8/1.8
YD160L	8/6/4	720/970/1460	4.5/6/7.5	13.8/14.5/15.6	80/83/84	0.62/0.76/0.87	5.5/6/7	1.7/1.4/1.5	1.8/1.8/1.8

YKK

系列6kV/10kV中型高压三相异步电动机
SERIES 6kV/10kV MEDIUM-SIZED HIGH-VOLTAGE
THREE-PHASE ASYNCHRONOUS MOTORS



简介 INTRODUCTION:

YKK系列中型电动机(机座号355-630)是本厂研制的最新产品,它的功率等级,安装尺寸,电气性能均符合国家标准GB755-2000和相关的IEC标准,电动机采用箱式结构,机座采用钢板焊接而成,重量轻,刚度好,电动机顶部采用封闭式空-空冷却器,拆装方便,便于电动机的维护和修理。定子采用外压装结构,顶部有可靠的固定及绑扎,在制造过程中经过多次匝间脉冲电压试验和对地耐压试验,并采用先进真空压力浸渍无溶剂漆设备及工艺(VPI)处理。鼠笼转子采用先进可靠的铸铝制造工艺制造而成,轴承有滚动轴承和滑动轴承两种型式,依电机功率大小和转速而定,也可按订货要求提供其它电压频率的和防护等级的电机。

YKK系列中型高压电动机具有高效节能,噪声低,振动小,运行可靠,安装维修方便等优点。
YKK系列电动机适用于驱动不同机械所用,如通风机,压缩机,水泵,破碎机,切削机床,运输机械及其它设备,在矿山、机械工业、石油化工业、发电等各行各业中作原动机用。用以传动鼓风机、磨煤机、轧钢机、卷扬机的电动机应在订货时注明用途及技术要求,采用特殊的设计以保证电机可靠运行。
YKK series medium-size motors (H355-630) are our new products, its output range, dimension of installation, and electric performance are in conformity with correlative national standard GB755-2000 and relative IEC standard. The motor adopts compacted box structure, welding-jointed steel plate for its frame, light weight, rigid in construction, there is closed air to air coolers on top of the stator frame convenient for installation and maintenance. The stator is so constructed as the stator core is stacked and assembled with coils to form an individual assembly which is then put into the stator housing, rigidly supported and braced at the end portion. During processing, the coils undergo several turn and turn pulse voltage tests and voltage endurance test to ground and vacuum pressure impregnated with solvent free varnish, pass several impulse voltage test among the wind and endure-voltage test, treated with advanced, squirrel rotor is made of pure aluminum under adopting advanced casting technique.

Depending on the output and speed of the motor rolling bearing or sleeve bearing is used. Other voltage/frequency and protection class motor can also provided upon order request YKK series motors have good features: High efficient, low noise, slight vibration, reliable operating, convenient installation and maintenance YKK series 10kV motors are applicable for driving various types of universal machines, such as compressor, pump, crusher, cutting machine tools, transportation equipment and other mechanical equipment, and act as prime mover at mine, mechanical industry, petroleum and chemical industry, power plant and other industrial purpose. if they are to be used to drive fan, coal-grind machine, rolling mill, windlass, relevant technical information should be provided when placing an order based on which special consideration will be given to the motors so as to ensure motor reliable operation.

使用条件 OPERATING CONDITIONS

环境温度: -15°C<Q<40°C 海拔: 不超过1000M
额定电压: 6kV/10kV 额定频率: 50HZ 防护等级: IP44/IP54 绝缘等级: F
Ambient temperature: -15°C<q<40°C Altitude: not exceed 1000M
Rated voltage: 6kV/10kV Rated frequency: 50Hz Protection class: IP44/IP54 Insulation class: F

型号含义(Nomenclature)



机外形图及安装尺寸(6kV)
OUNTING DIMENSION(6kV)

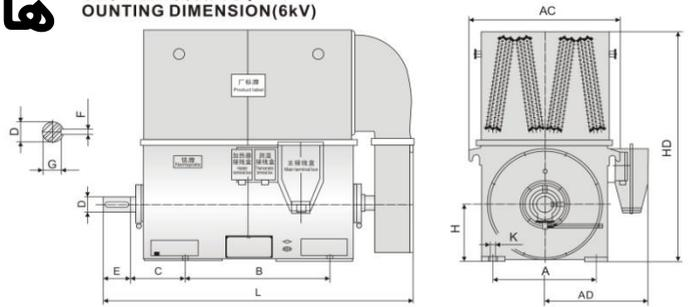

YKK系列6kV (YKK Series 6kV)

机座 Frame Size	极数 Pole	安装尺寸及公差 Mounting Dimension And Tolerance														外型尺寸(限值) Overall Dimension				
		A	B	C	D	E	F	G	H	K	AC	AD	HD	L						
355	2	630	+1.4 -1.4	900	+1.4 -1.4	315	80	+0.030 +0.011	170	+0.50 -0.50	22	71	355	28	+0.52 0	1120	1000	1500	2200	
	4-6					100	210	+0.57 -0.57	25	0	90									
400	2	710		1000		375	90	+0.035 +0.013	170	+0.50 -0.50	25	-0.052	80	400	35	1260	1050	1700	2400	
	4-6					335	110													
450	2	800	+1.75 -1.75	1120	+1.75 -1.75	400	100		210	+0.57 -0.57	28	90	450	0	0	1420	1100	1900	2600	
	4-6					355	120					109	0	-0.2	119					
500	2	900		1250		560	110	+0.035 +0.013	210	+0.57 -0.57	28	0	100	500	-1.0	+0.62 0	1600	1150	2200	2900
	4-6					475	130				32	119								
560	2	1000	+2.10 -2.10	1400	+2.10 -2.10	560	130		250	+0.57 -0.57	32	119	560	0	0	1800	1250	2400	3200	
	4-6					500	150	+0.040 +0.015	300	+0.65 -0.65	40	0	138							
630	2	1120		1600		560	140		250	+0.57 -0.57	36	128	630	-0.3	0	1800	1250	2400	3200	
	4-6					530	170		300	+0.65 -0.65	40	157								

注：表中数据仅供用户参考。
Note: Data in the table are for reference only

YKK系列10kV (YKK Series 10kV)

机座 Frame Size	极数 Pole	安装尺寸及公差 Mounting Dimension And Tolerance														外型尺寸(限值) Overall Dimension			
		A	B	C	D	E	F	G	H	K	AC	AD	HD	L					
450	2	800	+1.75 -1.75	1120	+1.75 -1.75	400	90		170	+0.50	25	81	450	35	1420	1100	1900	2600	
	4-6					355	110	+0.035 +0.013	210	+0.57 -0.57	28	-0.052	109	0	0	1420	1050	1475	2600
500	2	900		1250		560	100		210	+0.57 -0.57	32	119	500	0	0	1600	1150	2200	2900
	4-6					475	120					109	-0.2			1420	1080	1700	2900
560	2	1000	+2.10 -2.10	1400	+2.10 -2.10	560	130		250	+0.57 -0.57	36	119	560	0	0	1800	1250	2400	3200
	4-6					500	150	+0.040 +0.015	300	+0.65 -0.65	40	0	138	-1.0					
630	2	1120		1600		560	140		250	+0.57 -0.57	36	128	630	-0.3	0	1800	1250	2400	3200
	4-6					530	170		300	+0.65 -0.65	40	157							

注：表中数据仅供用户参考。
Note: Data in the table are for reference only

YKK6kV技术数据 TECHNICAL DATA(6kV)

型号 Model	额定功率 Rated Output (kW)	效率 Eff (%)	功率因素 Power Factor	同步转速 Synchronous Speed (r/min)	堵转转矩 额定转矩 Tstart/Tn (Standard)	堵转电流 额定电流 Ist/In (Standard)	最大转矩 额定转矩 Tmax/Tn (Standard)	重量 Weight (kg)
YKK3551-2	220	92.5	0.85	2963	0.6	7.0	1.8	2470
YKK3552-2	250	92.6	0.85	2963	0.6	7.0	1.8	2700
YKK3553-2	280	92.8	0.85	2963	0.6	7.0	1.8	2730
YKK3554-2	315	93.1	0.85	2963	0.6	7.0	1.8	2750
YKK4001-2	355	93.4	0.86	2963	0.6	7.0	1.8	3540
YKK4002-2	400	93.7	0.86	2963	0.6	7.0	1.8	3570
YKK4003-2	450	94	0.86	2973	0.6	7.0	1.8	3590
YKK4004-2	500	94.2	0.86	2973	0.6	7.0	1.8	3620
YKK4501-2	560	94.4	0.86	2973	0.6	7.0	1.8	4235
YKK4502-2	630	94.6	0.87	2973	0.6	7.0	1.8	4300
YKK4503-2	710	94.7	0.87	2800	0.6	7.0	1.8	4365
YKK4504-2	800	94.8	0.87	2800	0.6	7.0	1.8	4430
YKK5001-2	900	95	0.87	2800	0.6	7.0	1.8	5310
YKK5002-2	1000	95.1	0.87	2800	0.6	7.0	1.8	5510
YKK5003-2	1120	95.2	0.87	2800	0.6	7.0	1.8	5710
YKK5004-2	1250	95.3	0.87	2800	0.6	7.0	1.8	5910
YKK5601-2	1400	95.4	0.88	2800	0.6	7.0	1.8	6700
YKK5602-2	1600	95.5	0.88	2800	0.6	7.0	1.8	7100
YKK5603-2	1800	95.6	0.88	2891	0.6	7.0	1.8	7500
YKK6301-2	2000	95.7	0.88	2891	0.6	7.0	1.8	9400
YKK6302-2	2240	95.8	0.88	2891	0.6	7.0	1.8	9800
YKK6303-2	2500	95.9	0.88	2891	0.6	7.0	1.8	1020
YKK3551-4	185	92.8	0.85	1480	0.7	6.5	1.8	2280
YKK3552-4	200	92.9	0.85	1480	0.7	6.5	1.8	2325
YKK3553-4	220	93.0	0.85	1480	0.7	6.5	1.8	2390
YKK3554-4	250	93.1	0.85	1480	0.7	6.5	1.8	2450
YKK4001-4	280	93.2	0.86	1480	0.7	6.5	1.8	3780
YKK4002-4	315	93.3	0.86	1480	0.7	6.5	1.8	3845
YKK4003-4	355	93.5	0.86	1480	0.7	6.5	1.8	3925
YKK4004-4	400	93.7	0.86	1480	0.7	6.5	1.8	4050
YKK4005-4	450	93.9	0.86	1480	0.7	6.5	1.8	4160
YKK4502-4	500	94.0	0.86	1485	0.7	6.5	1.8	4370
YKK4503-4	560	94.2	0.86	1485	0.7	6.5	1.8	4460
YKK4504-4	630	94.4	0.86	1485	0.7	6.5	1.8	4630
YKK4505-4	710	94.6	0.86	1485	0.7	6.5	1.8	4680
YKK5001-4	800	94.8	0.87	1485	0.7	6.5	1.8	5740
YKK5002-4	900	94.9	0.87	1485	0.7	6.5	1.8	5830
YKK5003-4	1000	95.0	0.87	1485	0.7	6.5	1.8	6025
YKK5004-4	1120	95.1	0.87	1485	0.7	6.5	1.8	6235
YKK5601-4	1250	95.2	0.88	1480	0.6	6.5	1.8	7150
YKK5602-4	1400	95.3	0.88	1480	0.6	6.5	1.8	8100
YKK5603-4	1600	95.4	0.88	1480	0.6	6.5	1.8	9050
YKK6301-4	1800	95.5	0.88	1480	0.6	6.5	1.8	11250
YKK6302-4	2000	95.6	0.88	1480	0.6	6.5	1.8	12200
YKK6303-4	2240	95.7	0.88	1480	0.6	6.5	1.8	13100
YKK3553-6	185	92.4	0.82	985	0.8	6.0	1.8	2470
YKK3554-6	200	92.6	0.82	985	0.8	6.0	1.8	2520
YKK4002-6	220	92.8	0.82	985	0.7	6.0	1.8	3860
YKK4003-6	25	93.0	0.82	985	0.7	6.0	1.8	3900
YKK4004-6	280	93.3	0.82	985	0.7	6.0	1.8	3950
YKK4005-6	315	93.5	0.82	985	0.7	6.0	1.8	4060
YKK4502-6	355	93.7	0.83	985	0.7	6.0	1.8	4300
YKK4503-6	400	93.8	0.83	985	0.7	6.0	1.8	4350
YKK4504-6	450	94.1	0.83	985	0.7	6.0	1.8	4470
YKK4505-6	500	94.3	0.83	985	0.7	6.0	1.8	4600
YKK5001-6	560	94.4	0.84	985	0.7	6.0	1.8	5515
YKK5002-6	630	94.5	0.84	985	0.7	6.0	1.8	5590

DATA(6kV)

型号 Model	额定功率 Rated Output (kW)	效率 Eff (%)	功率因素 Power Factor	同步转速 Synchronous Speed (r/min)	堵转转矩 Tstart/Tn (Standard)	堵转电流 Ist/In (Standard)	最大转矩 Tmax/Tn (Standard)	重量 Weight (kg)
YKK5004-6	800	94.9	0.84	985	0.7	6.0	1.8	5810
YKK5601-6	900	95.0	0.85	985	0.7	6.5	1.8	7650
YKK5602-6	1000	95.1	0.85	985	0.7	6.5	1.8	7780
YKK5603-6	1120	95.2	0.85	985	0.7	6.5	1.8	7900
YKK6301-6	1250	95.3	0.86	985	0.7	6.5	1.8	8730
YKK6302-6	1400	95.4	0.86	985	0.7	6.5	1.8	11250
YKK6303-6	1600	95.5	0.86	985	0.7	6.5	1.8	10250
YKK4003-8	185	92.5	0.78	740	0.8	5.5	1.8	3830
YKK4004-8	200	92.7	0.78	740	0.8	5.5	1.8	3890
YKK4005-8	220	92.9	0.78	740	0.8	5.5	1.8	3940
YKK4502-8	250	93.0	0.79	740	0.8	5.5	1.8	4110
YKK4503-8	280	93.2	0.79	740	0.8	5.5	1.8	4200
YKK4504-8	315	93.4	0.79	740	0.8	5.5	1.8	4330
YKK4505-8	355	93.5	0.79	740	0.8	5.5	1.8	4460
YKK5001-8	400	93.7	0.80	740	0.8	5.5	1.8	5265
YKK5002-8	450	93.8	0.80	740	0.8	5.5	1.8	5425
YKK5003-8	500	94.2	0.80	740	0.8	5.5	1.8	5605
YKK5004-8	560	94.4	0.80	740	0.8	5.5	1.8	5775
YKK5601-8	630	94.5	0.82	740	0.7	6.0	1.8	6850
YKK5602-8	710	94.6	0.82	740	0.7	6.0	1.8	7050
YKK5603-8	800	94.7	0.82	740	0.7	6.0	1.8	7300
YKK6301-8	900	94.8	0.84	740	0.7	6.0	1.8	8270
YKK6302-8	1000	94.9	0.84	740	0.7	6.0	1.8	8675
YKK6303-8	1120	95.0	0.84	740	0.7	6.0	1.8	9080
YKK6304-8	1250	95.1	0.84	740	0.7	6.0	1.8	9485
YKK4501-10	185	91.7	0.75	590	0.8	5.5	1.8	4080
YKK4502-10	200	91.9	0.75	590	0.8	5.5	1.8	4130
YKK4503-10	220	92.1	0.75	590	0.8	5.5	1.8	4210
YKK4504-10	250	92.3	0.75	590	0.8	5.5	1.8	4280
YKK4505-10	280	92.5	0.75	590	0.8	5.5	1.8	4520
YKK5001-10	315	92.8	0.76	590	0.8	5.5	1.8	5280
YKK5002-10	355	93.0	0.76	590	0.8	5.5	1.8	5375
YKK5003-10	400	93.3	0.76	590	0.8	5.5	1.8	5540
YKK5004-10	450	93.4	0.76	590	0.8	5.5	1.8	5700
YKK5601-10	500	93.6	0.80	590	0.7	6.0	1.8	5895
YKK5602-10	560	93.7	0.80	590	0.7	6.0	1.8	6100
YKK5603-10	630	93.8	0.80	590	0.7	6.0	1.8	6150
YKK5604-10	710	94.0	0.80	590	0.7	6.0	1.8	6300
YKK6301-10	800	94.2	0.82	590	0.7	6.0	1.8	9250
YKK6302-10	900	94.3	0.82	590	0.7	6.0	1.8	9550
YKK6303-10	1000	94.4	0.82	590	0.7	6.0	1.8	9850
YKK6304-10	1120	94.6	0.82	590	0.7	6.0	1.8	10400
YKK4504-12	185	91.8	0.70	490	0.8	5.5	1.8	4350
YKK4505-12	200	92.0	0.70	490	0.8	5.5	1.8	4370
YKK5001-12	220	92.2	0.72	490	0.8	5.5	1.8	5220
YKK5002-12	250	92.5	0.72	490	0.8	5.5	1.8	5395
YKK5003-12	280	92.7	0.72	490	0.8	5.5	1.8	5555
YKK5004-12	315	92.8	0.72	490	0.8	5.5	1.8	5815
YKK5601-12	355	93.0	0.75	490	0.7	6.0	1.8	6075
YKK5602-12	400	93.3	0.75	490	0.7	6.0	1.8	7060
YKK5603-12	450	93.4	0.75	490	0.7	6.0	1.8	7340
YKK5604-12	500	93.7	0.75	490	0.7	6.0	1.8	7620
YKK6301-12	560	93.8	0.78	490	0.7	6.0	1.8	7900
YKK6302-12	630	93.9	0.78	490	0.7	6.0	1.8	10700
YKK6303-12	710	94.0	0.78	490	0.7	6.0	1.8	10980
YKK6304-12	800	94.2	0.78	490	0.7	6.0	1.8	11260

YKK10kV技术数据 TECHNICAL DATA(10kV)

型号 Model	额定功率 Rated Output (kW)	效率 Eff (%)	功率因素 Power Factor	同步转速 Synchronous Speed (r/min)	堵转转矩 Tstart/Tn (Standard)	堵转电流 Ist/In (Standard)	最大转矩 Tmax/Tn (Standard)	重量 Weight (kg)
YKK4501-2	220	92.4	0.85	3000	0.6	7.0	1.8	3700
YKK4502-2	250	92.6	0.85	3000	0.6	7.0	1.8	3760
YKK4503-2	280	92.8	0.85	3000	0.6	7.0	1.8	3860
YKK4504-2	315	93	0.85	3000	0.6	7.0	1.8	3890
YKK4505-2	355	93.3	0.86	3000	0.6	7.0	1.8	4200
YKK4506-2	400	93.7	0.86	3000	0.6	7.0	1.8	4300
YKK4507-2	450	94	0.86	3000	0.6	7.0	1.8	4490
YKK5001-2	500	94.2	0.86	3000	0.6	7.0	1.8	5640
YKK5002-2	560	94.4	0.86	3000	0.6	7.0	1.8	5660
YKK5003-2	630	94.6	0.87	3000	0.6	7.0	1.8	5850
YKK5004-2	710	94.7	0.87	3000	0.6	7.0	1.8	6030
YKK5005-2	800	94.8	0.87	3000	0.6	7.0	1.8	6060
YKK5601-2	900	94.9	0.87	3000	0.6	7.0	1.8	7800
YKK5602-2	1000	95	0.87	3000	0.6	7.0	1.8	8050
YKK5603-2	1120	95.2	0.87	3000	0.6	7.0	1.8	8300
YKK6301-2	1250	95.3	0.87	3000	0.6	7.0	1.8	9900
YKK6302-2	1400	95.4	0.87	3000	0.6	7.0	1.8	10300
YKK6303-2	1600	95.5	0.87	3000	0.6	7.0	1.8	10400
YKK4501-4	220	92.4	0.83	1500	0.6	7.0	1.8	3700
YKK4502-4	250	92.6	0.83	1500	0.6	7.0	1.8	3760
YKK4503-4	280	92.8	0.83	1500	0.6	7.0	1.8	3860
YKK4504-4	315	93	0.83	1500	0.6	7.0	1.8	3890
YKK4505-4	355	93.3	0.86	1500	0.6	7.0	1.8	4200
YKK4506-4	400	93.5	0.86	1500	0.6	7.0	1.8	4300
YKK4507-4	450	93.8	0.86	1500	0.6	7.0	1.8	4490
YKK5001-4	500	94	0.86	1500	0.6	7.0	1.8	5640
YKK5002-4	560	94.2	0.86	1500	0.6	7.0	1.8	5660
YKK5003-4	630	94.4	0.86	1500	0.6	7.0	1.8	5850
YKK5004-4	710	94.6	0.86	1500	0.6	7.0	1.8	6030
YKK5005-4	800	94.8	0.87	1500	0.6	7.0	1.8	6060
YKK5601-4	900	94.9	0.87	1500	0.6	7.0	1.8	7800
YKK5602-4	1000	95	0.87	1500	0.6	7.0	1.8	8050
YKK5603-4	1120	95.1	0.87	1500	0.6	7.0	1.8	8300
YKK6301-4	1250	95.2	0.88	1500	0.6	7.0	1.8	9900
YKK6302-4	1400	95.3	0.88	1500	0.6	7.0	1.8	10300
YKK6303-4	1600	95.4	0.88	1500	0.6	7.0	1.8	10400
YKK4504-6	220	92	0.8	1000	0.7	6.0	1.8	3890
YKK4505-6	250	92.2	0.8	1000	0.7	6.0	1.8	4200
YKK4506-6	280	92.5	0.8	1000	0.7	6.0	1.8	4300
YKK4507-6	315	92.8	0.82	1000	0.7	6.0	1.8	4490
YKK5001-6	355	93.1	0.83	1000	0.7	6.0	1.8	5640
YKK5002-6	400	93.3	0.83	1000	0.7	6.0	1.8	5660
YKK5003-6	450	93.5	0.83	1000	0.7	6.0	1.8	5850

DATA(10kV)

型号	功率 (kW)	功率因数	同步转速 (r/min)	堵转转矩 (Tstart/Tn)	堵转电流 (Ist/In)	最大转矩 (Tmax/Tn)	重量 (kg)
YKK5005-6	560	94.1	1000	0.7	6.0	1.8	6030
YKK5601-6	630	94.4	1000	0.7	6.0	1.8	7800
YKK5602-6	710	94.6	1000	0.7	6.0	1.8	8050
YKK5603-6	800	94.7	1000	0.7	6.0	1.8	8300
YKK5604-6	900	94.9	1000	0.7	6.0	1.8	8500
YKK6301-6	1000	95.1	1000	0.6	6.0	1.8	9900
YKK6302-6	1120	95.2	1000	0.6	6.0	1.8	10300
YKK6303-6	1250	95.3	1000	0.6	6.0	1.8	10400
YKK5001-8	200	92	750	0.7	6.0	1.8	5640
YKK5002-8	250	92.2	750	0.7	6.0	1.8	5660
YKK5003-8	280	92.5	750	0.7	6.0	1.8	5850
YKK5004-8	315	92.8	750	0.7	6.0	1.8	6030
YKK5005-8	355	93.1	750	0.7	6.0	1.8	6060
YKK5006-8	400	93.2	750	0.7	6.0	1.8	5820
YKK5601-8	450	93.4	750	0.7	6.0	1.8	7800
YKK5602-8	500	93.8	750	0.7	6.0	1.8	8050
YKK5603-8	560	93.9	750	0.7	6.0	1.8	8300
YKK5604-8	630	94.9	750	0.7	6.0	1.8	8500
YKK6301-8	710	94.6	750	0.7	6.0	1.8	9900
YKK6302-8	800	94.7	750	0.7	6.0	1.8	10300
YKK6303-8	900	94.8	750	0.7	6.0	1.8	10400
YKK5003-10	220	91.9	600	0.7	5.5	1.8	5850
YKK5004-10	250	92.1	600	0.7	5.5	1.8	6030
YKK5005-10	280	92.4	600	0.7	5.5	1.8	6060
YKK5601-10	315	92.6	600	0.7	6.0	1.8	7800
YKK5602-10	355	92.8	600	0.7	6.0	1.8	8050
YKK5603-10	400	93	600	0.7	6.0	1.8	8300
YKK5604-10	450	93.2	600	0.7	6.0	1.8	8500
YKK5605-10	500	93.4	600	0.7	6.0	1.8	8300
YKK6301-10	560	93.5	600	0.7	6.0	1.8	9900
YKK6302-10	630	93.7	600	0.7	6.0	1.8	10300
YKK6303-10	710	93.9	600	0.7	6.0	1.8	10400
YKK6304-10	800	94.3	600	0.7	6.0	1.8	11800
YKK5601-12	220	91.8	500	0.7	6.0	1.8	7800
YKK5602-12	250	92	500	0.7	6.0	1.8	8050
YKK5603-12	280	92.1	500	0.7	6.0	1.8	8300
YKK5604-12	315	92.3	500	0.7	6.0	1.8	8500
YKK5605-12	355	92.5	500	0.7	6.0	1.8	8300
YKK6301-12	400	92.7	500	0.7	6.0	1.8	9900
YKK6302-12	450	92.9	500	0.7	6.0	1.8	10300
YKK6303-12	500	93.2	500	0.7	6.0	1.8	10400
YKK6304-12	560	93.5	500	0.7	6.0	1.8	11800

电动机铭牌 Nameplate of Motor

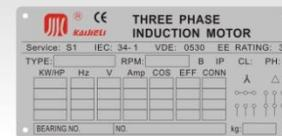
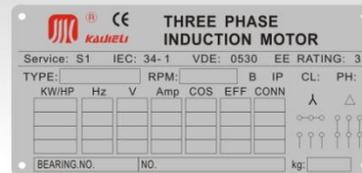

接线图 Connection diagram

三相电机接线图
Three phase motor

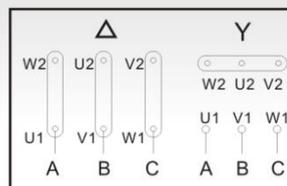

单相电机接线图
Single phase motor

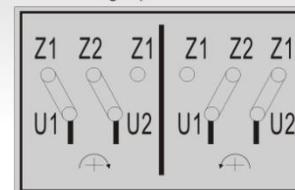

防护等级 Protection class

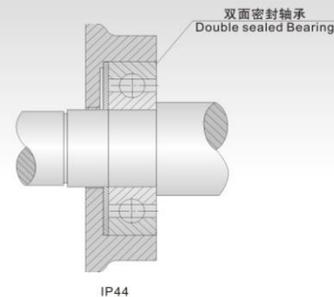

IP44

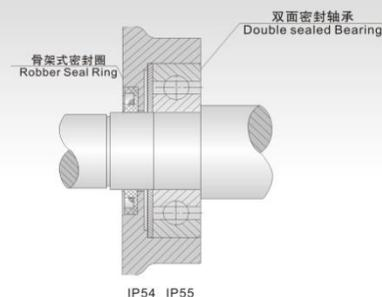

IP54 IP55

in Drive Shaft

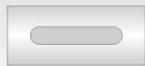

闭口槽 Closed Keyway



开口槽 Open Keyway

安装结构形式 Mounting construction

基本结构形式 Fundamental construction	B3					
安装结构形式 Mounting construction	B3	B6	B7	B8	V5	V6
示意图 Diagram						
制造范围 (机座号) Range of manufacture (frame size)	63-355	63-160				

基本结构形式 Fundamental construction	B5			B35		
安装结构形式 Mounting construction	B5	V1	V3	B35	V15	V36
示意图 Diagram						
制造范围 (机座号) Range of manufacture (frame size)	63-280	63-355	63-160	63-355	63-160	

基本结构形式 Fundamental construction	小凸缘式 Small flange type		
安装结构形式 Mounting construction	B14	B34	V18
示意图 Diagram			
制造范围 (机座号) Range of manufacture (frame size)	63-112		

*电动机的安装方式符合IEC34-7的规定 The mounting constructions of the motors comply with IEC34-7 recommendation.



- 美、澳、非洲区域 America, Australia & Africa
Tel: 0086-512-66658651
- 欧洲区域 Europe
Tel: 0086-512-66659568
- 中东区域 Middle East
Tel: 0086-512-66658698
- 南亚区域 South Asia
Tel: 0086-512-66659178
- 东南亚区域 South East Asia
Tel: 0086-512-66659078

