

Catalog | May 2014

Low voltage Process performance motors according to Australian MEPS

We provide motors and generators, services and expertise to save energy and improve customers' processes over the total lifecycle of our products, and beyond.



Low voltage Process performance motors

Sizes 63 to 450, 0.09 to 1000 kW

General information	4
Cast iron motors	17
Ordering information	18
Rating plates	19
Technical data	20
Variant codes	31
Mechanical design	38
Dimension drawings	57
Accessories	71
Cast iron motors in brief	77
Cast iron motor construction	80
Aluminum motors	81
Ordering information	82
Rating plates	83
Technical data	84
Variant codes	88
Mechanical design	94
Dimension drawings	105
Accessories	121
Aluminum motors in brief	122
Total product offering	126
Life cycle services and support	127

International motor efficiency standards

Since the validation of IEC/EN 60034-30, a worldwide energy efficiency classification system has existed for low voltage three-phase asynchronous motors. This system increases the level of harmonization in efficiency regulations around the world and also covers motors for explosive atmospheres. IEC/EN 60034-30:2008 defines International Efficiency (IE) classes for single speed, three-phase, 50 and 60 Hz induction motors. The standard is part of an effort to unify motor testing procedures as well as efficiency and product labeling requirements to enable motor purchasers worldwide to easily recognize premium efficiency products. The efficiency levels defined in IEC/EN 60034-30 are based on test methods specified in IEC/EN 60034-2-1:2007.

To promote transparency in the market, IEC 60034-30 states that both the efficiency class and efficiency value must be shown on the motor rating plate and in product documentation. The documentation must clearly indicate the efficiency testing method used as the different methods can produce differing results.

Minimum energy performance standards

While the IEC sets guidelines for motor testing and efficiency classes, the organization does not regulate efficiency. The biggest drivers for mandatory Minimum Energy Performance Standard (MEPS) levels for electric motors are global climate change, government targets to cut the CO₂ emissions and rising electricity demand, especially in developing countries. The whole value chain, from manufacturer up to end user, must be aware of the legislation in order to meet local requirements and additionally save energy and reduce carbon footprint.

Harmonized standards and the increasing adoption of MEPS around the world are good news. However, it is important to remember that harmonization is an ongoing process. Even though MEPS are already in effect in several regions, they are evolving and they differ in terms of scope and requirements. At the same time, new countries are planning to adopt their own MEPS. To get the latest information please visit www.abb.com/motors&generators/energyefficiency.

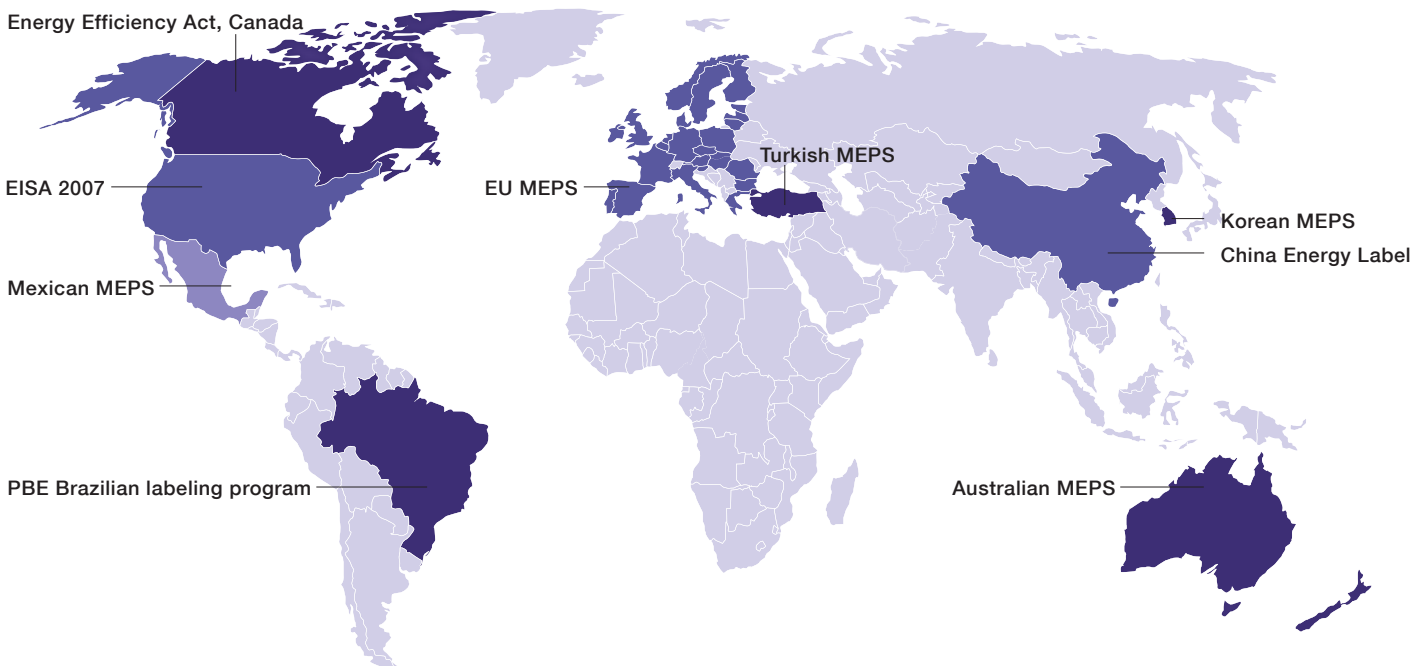

IEC/EN 60034-30:2008

IEC/EN 60034-30:2008 defines three International Efficiency (IE) classes for single speed, three-phase, cage induction motors. Additionally, IEC/TS 60034-31 specifies efficiency class IE4.

- IE1 = Standard efficiency (EFF2 in the former European classification scheme)
- IE2 = High efficiency (EFF1 in the former European classification scheme and identical to EPart in the USA for 60 Hz)
- IE3 = Premium efficiency (identical to “NEMA Premium” in the USA for 60 Hz)
- IE4 = Super premium efficiency, according to IEC/TS 60034-31

Efficiency levels defined in IEC/EN 60034-30 are based on test methods specified in IEC/EN 60034-2-1:2007.

Compared to the former European efficiency classes defined by the CEMEP agreement the scope has been expanded.

IEC/EN 60034-30 covers almost all motors (for example standard, hazardous area, marine, brake motors)

- Single speed, three-phase, 50 Hz and 60 Hz
- 2-, 4- or 6-pole
- Rated output from 0.75 to 375 kW
- Rated voltage UN up to 1000 V
- Duty type S1 (continuous duty) or S3 (intermittent periodic duty) with a rated cyclic duration factor of 80 % or higher
- Capable of operating direct online

The following motors are excluded from IEC 60034-30:

- Motors made solely for converter operation
- Motors completely integrated into a machine (for example, pump, fan or compressor) that cannot be tested separately from the machine

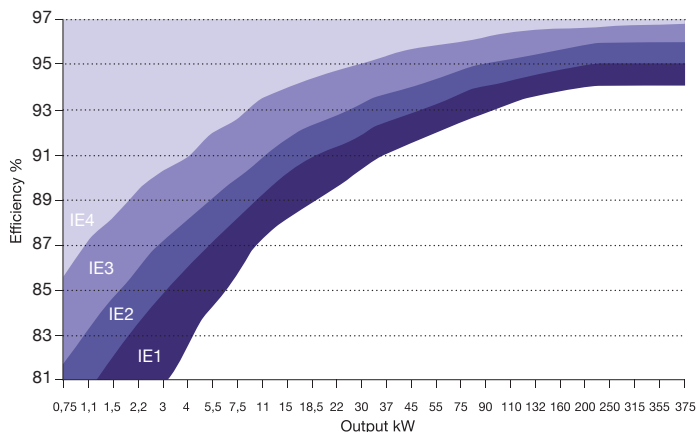

IE Classes - 4-pole motors

Minimum efficiency values defined in IEC 60034-30:2008 (based on test methods specified in IEC 60034-2-1:2007)

Output kW	IE1 Standard efficiency			IE2 High efficiency			IE3 Premium efficiency		
	2 pole	4 pole	6 pole	2 pole	4 pole	6 pole	2 pole	4 pole	6 pole
0.75	72.1	72.1	70.0	77.4	79.6	75.9	80.7	82.5	78.9
1.1	75.0	75.0	72.9	79.6	81.4	78.1	82.7	84.1	81.0
1.5	77.2	77.2	75.2	81.3	82.8	79.8	84.2	85.3	82.5
2.2	79.7	79.7	77.7	83.2	84.3	81.8	85.9	86.7	84.3
3	81.5	81.5	79.7	84.6	85.5	83.3	87.1	87.7	85.6
4	83.1	83.1	81.4	85.8	86.6	84.6	88.1	88.6	86.8
5.5	84.7	84.7	83.1	87.0	87.7	86.0	89.2	89.6	88.0
7.5	86.0	86.0	84.7	88.1	88.7	87.2	90.1	90.4	89.1
11	87.6	87.6	86.4	89.4	89.8	88.7	91.2	91.4	90.3
15	88.7	88.7	87.7	90.3	90.6	89.7	91.9	92.1	91.2
18.5	89.3	89.3	88.6	90.9	91.2	90.4	92.4	92.6	91.7
22	89.9	89.9	89.2	91.3	91.6	90.9	92.7	93.0	92.2
30	90.7	90.7	90.2	92.0	92.3	91.7	93.3	93.6	92.9
37	91.2	91.2	90.8	92.5	92.7	92.2	93.7	93.9	93.3
45	91.7	91.7	91.4	92.9	93.1	92.7	94.0	94.2	93.7
55	92.1	92.1	91.9	93.2	93.5	93.1	94.3	94.6	94.1
75	92.7	92.7	92.6	93.8	94.0	93.7	94.7	95.0	94.6
90	93.0	93.0	92.9	94.1	94.2	94.0	95.0	95.2	94.9
110	93.3	93.3	93.3	94.3	94.5	94.3	95.2	95.4	95.1
132	93.5	93.5	93.5	94.6	94.7	94.6	95.4	95.6	95.4
160	93.7	93.8	93.8	94.8	94.9	94.8	95.6	95.8	95.6
200	94.0	94.0	94.0	95.0	95.1	95.0	95.8	96.0	95.8
250	94.0	94.0	94.0	95.0	95.1	95.0	95.8	96.0	95.8
315	94.0	94.0	94.0	95.0	95.1	95.0	95.8	96.0	95.8
355	94.0	94.0	94.0	95.0	95.1	95.0	95.8	96.0	95.8
375	94.0	94.0	94.0	95.0	95.1	95.0	95.8	96.0	95.8

ABB and efficiency standards

ABB determines efficiency values according to IEC/EN 60034-2-1 using the low uncertainty method (i.e. indirect method), with additional load losses determined by measurement.

As the world market leader, ABB offers the largest range of LV motors available. It has long advocated the need for efficiency in motors, and high efficiency products have formed the core of its portfolio for many years. The core of ABB's Process performance range is based on full range in IE2 and IE3 motors - with many available from stock. Super premium efficiency IE4 motors also available.

Rated Power kW	Minimum Efficiency %			
	2-pole	4-pole	6-pole	8-pole
0.73	78.8	80.5	76.0	71.8
0.75	78.8	80.5	76.0	71.8
1.1	80.6	82.2	78.3	74.7
1.5	82.6	83.5	79.9	76.8
2.2	84.0	84.9	81.9	79.4
3	85.3	86.0	83.5	81.3
4	86.3	87.0	84.7	82.8
5.5	87.2	87.9	86.1	84.5
7.5	88.3	88.9	87.3	86.0
11	89.5	89.9	88.7	87.7
15	90.3	90.8	89.6	88.9
18.5	90.8	91.2	90.3	89.7
22	91.2	91.6	90.8	90.2
30	92.0	92.3	91.6	91.2
37	92.5	92.8	92.2	91.8
45	92.9	93.1	92.7	92.4
55	93.2	93.5	93.1	92.9
75	93.9	94.0	93.7	93.7
90	94.2	94.4	94.2	94.1
110	94.5	94.7	94.5	94.5
132	94.8	94.9	94.8	94.8
150	95.0	95.2	95.1	95.2
< 185	95.0	95.2	95.1	95.2

Table 1: Minimum efficiency level – Test Method A

Rated Power kW	Minimum Efficiency %			
	2-pole	4-pole	6-pole	8-pole
0.73	81.4	82.9	78.8	75.0
0.75	81.4	82.9	78.8	75.0
1.1	83.0	84.5	80.9	77.6
1.5	84.8	85.6	82.4	79.6
2.2	86.2	86.9	84.2	81.9
3	87.2	87.8	85.6	83.6
4	88.1	88.7	86.7	85.0
5.5	88.9	89.5	87.9	86.5
7.5	89.9	90.4	89.0	87.8
11	90.9	91.3	90.2	89.3
15	91.6	92.1	91.0	90.4
18.5	92.1	92.4	91.6	91.1
22	92.4	92.8	92.1	91.5
30	93.1	93.4	92.8	92.4
37	93.6	93.8	93.3	92.9
45	93.9	94.1	93.7	93.5
55	94.2	94.4	94.1	93.9
75	94.8	94.9	94.6	94.6
90	95.0	95.2	95.0	94.9
110	95.3	95.5	95.3	95.3
132	95.5	95.6	95.5	95.5
150	95.7	95.9	95.8	95.9
< 185	95.7	95.9	95.8	95.9

Table 2: High Efficiency (HE) level – Test Method A

Compliance and verification



The scheme is monitored by the Australian government which conducts random testing to ensure compliance. Importing unregistered products is subject to strict penalties.

Mounting arrangements

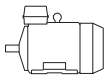
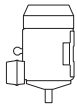
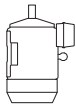
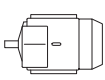
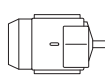
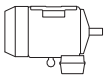
Foot-mounted motor

Code I / code II						Product code pos. 12
						A: foot-mounted, term.box top R: foot-mounted, term.box RHS L: foot-mounted, term.box LHS
IM B3	IM V5	IM V6	IM B6	IM B7	IM B8	
IM 1001	IM 1011	IM 1031	IM 1051	IM 1061	IM 1071	

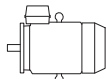
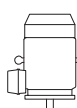
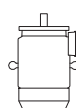
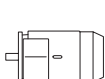
Flange-mounted motor, large flange

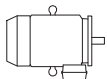
Code I / code II						Product code pos. 12
						B: flange mounted, large flange
IM B5	IM V1	IM V3	*)	*)	*)	
IM 3001	IM 3011	IM 3031	IM 3051	IM 3061	IM 3071	

Flange-mounted motor, small flange

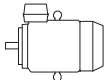
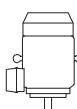
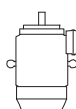
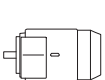
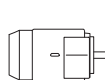
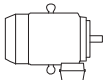
Code I / code II						Product code pos. 12
						C: flange mounted, small flange
IM B14	IM V18	IM V19	*)	*)	*)	
IM 3601	IM 3611	IM 3631	IM 3651	IM 3661	IM 3671	

Foot- and flange-mounted motor with feet, large flange

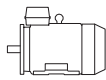
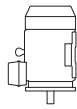
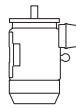
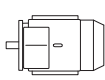
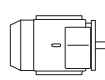
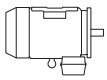
Code I / code II						Product code pos. 12
						H: foot/flange-mounted, term. box top S: foot/flange-mounted, term. box RHS
IM B35	IM V15	IM V36	*)	*)	*)	
IM 2001	IM 2011	IM 2031	IM 2051	IM 2061	IM 2071	

Foot- and flange-mounted motor with feet, small flange

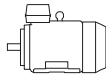
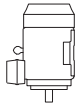
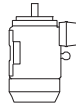
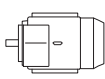
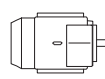
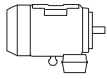
Code I / code II						Product code pos. 12
						T: foot/flangemounted, term. box RHS
IM B34	IM V17	IM 2131	IM 2151	IM 2161	IM 2171	
IM 2101	IM 2111	IM 2131	IM 2151	IM 2161	IM 2171	

Foot-mounted motor, shaft with free extensions

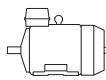
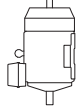
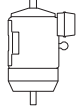
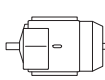
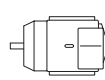
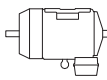
Code I / code II						Product code pos. 12
						J: foot/flangemounted, small flange
IM 1002	IM 1012	IM 1032	IM 1052	IM 1062	IM 1072	

*) Not stated in IEC 60034-7.

Note: If the motor is mounted shaft upwards, take measures to prevent water or any other liquid from running down the shaft into the motor.

Cooling

Designation system concerning methods of cooling refers to standard IEC 60034-6.

Explanation of the product code

International Cooling	Circuit arrangement	Primary coolant	Method of movement of primary coolant	Secondary coolant	Method of movement of secondary coolant
IC	4	(A)	1	(A)	6
	1	2	3	4	5

Position 1

- 0: Free circulation (open circuit)
- 4: Frame surface cooled

Position 2

- A: For air (omitted for simplified designation)

Position 3

- 0: Free convection
- 1: Self-circulation
- 6: Machine-mounted independent component

Position 4

- A: For air (omitted for simplified designation)
- W: For water

Position 5

- 0: Free convection
- 1: Self-circulation
- 6: Machine-mounted independent component
- 8: Relative displacement

Degrees of protection: IP code/IK code

Classification of degrees of protection provided by enclosures of rotating machines are refers to:

- Standard IEC 60034-5 or EN 60529 for IP code
- Standard EN 50102 for IK code

IP protection

Protection of persons against getting in contact with (or approaching) live parts and against contact with moving parts inside the enclosure. Also protection of the machine against ingress of solid foreign objects. Protection of machines against the harmful effects due to the ingress of water.

Explanation of the IP code

Ingress protection	Degree of protection to persons and to parts of the motors inside the enclosure	Degree of protection provided by the enclosure with respect to harmful effects due to ingress of water
IP	5	5
	1	2

Position 1

2:	Motors protected against solid objects greater than 12 mm
4:	Motors protected against solid objects greater than 1 mm
5:	Dust-protected motors
6:	Dust-tight motors

Position 2

3:	Motors protected against spraying water
4:	Motors protected against splashing water
5:	Motors protected against water jets
6:	Motors protected against heavy seas

IK code

Classification of degrees of protection provided by enclosure for motors against external mechanical impacts.

Explanation of the IK code

International mechanical protection	Characteristic group
IK	08
	1

Position 1

Relation between IK code and impact energy:

IK code	Impact energy/Joule
0:	Not protected according to EN 50102
01:	0.15
02:	0.2
03:	0.35
04:	0.5
05:	0.7
06:	1
07:	2
08:	5 (ABB Standard)
09:	10
10:	20

Insulation

ABB uses class F insulation, which, with temperature rise B, is the most common requirement among industry today.

The use of Class F insulation with Class B temperature rise gives ABB products a 25 °C safety margin. This can be used to increase the loading for limited periods, to operate at higher ambient temperatures or altitudes, or with greater voltage and frequency tolerances. It can also be used to extend insulation. For instance, a 10 K temperature reduction will extend the insulation life.

Thermal class 130 (B)

- Nominal ambient temperature 40 °C
- Max permissible temperature rise 80 K
- Hot spot temperature margin 10 K

Thermal class 155 (F)

- Nominal ambient temperature 40 °C
- Max permissible temperature rise 105 K
- Hotspot temperature margin 10 K

Thermal class 180 (H)

- Nominal ambient temperature 40 °C
- Max permissible temperature rise 125 K
- Hot spot temperature margin 10 K

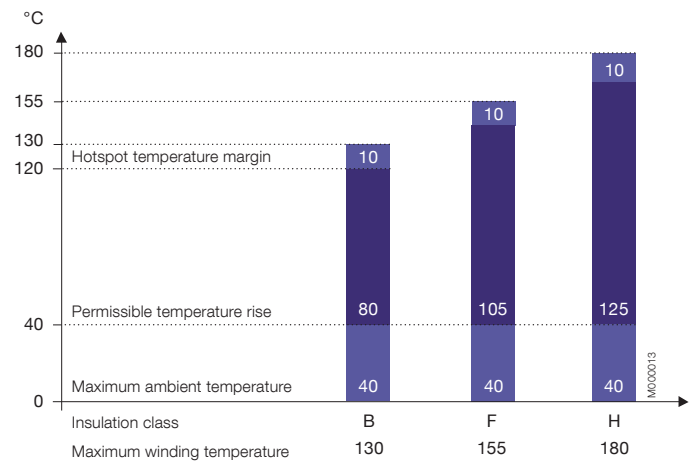

Safety margins per thermal class.

Surface treatment

The surface treatment categorization of ABB motors is based on the ISO 12944 standard. ISO 12994-5 divides paint system durability into three categories: low (L), medium (M), and high (H). Low durability corresponds to a lifetime of 2 - 5 years, medium to 5 – 15 years, and high durability to over 15 years.

The durability range is not a guaranteed lifetime. Its purpose is to help the owner of the motor plan for appropriate maintenance intervals. More frequent maintenance may be required because of fading, chalking, contamination, wear and tear, or for other reasons.

ABB's standard surface treatment is corrosivity category C3, durability range M (which equal to medium corrosivity and medium durability). Special surface treatment is available in corrosivity categories C4 and C5-M, durability class M for both. In addition, surface treatment according to the NORSOK standard for offshore environments is available as an option.

The standard ABB paint color for motors is Munsell blue 8B 4.5/3.25.

Corrosivity category	Outdoor atmospheres	Indoor atmospheres	Use in ABB motors
C1, very low	Not used	Heated buildings with clean atmospheres	Not available
C2, low	Atmospheres with low level pollution, mostly rural areas.	Unheated buildings where condensation may occur, such as depots and sports halls.	Not available
C3, medium	Urban and industrial atmospheres, moderate sulfur dioxide pollution. Coastal areas with low salinity.	Production rooms with high humidity and some air pollution; food processing plants, laundries, breweries, dairies.	Standard treatment
C4, high	Industrial areas and coastal areas with moderate salinity.	Chemical plants, swimming pools, coastal ship- and boatyards.	Optional treatment for cast iron motors, variant code 115
C5-I, very high (industrial)	Industrial areas and coastal areas with high humidity and aggressive atmosphere.	Buildings or areas with nearly permanent condensation and high pollution.	Not available
C5-M, very high (marine)	Coastal and offshore areas with high salinity.	Buildings or areas with nearly permanent condensation and high pollution.	Optional treatment for cast iron motors, variant code 754, 711

Atmospheric corrosivity categories and recommended environments.

Variable speed drives with Process performance motors

Squirrel cage induction motors offer excellent availability, reliability and efficiency. With a variable speed drive (VSD) – a frequency converter – the motor performance can be further improved. Instead of running the motor continuously at full speed, the VSD enables speed adjustment according to actual need. The VSD makes it possible to control the process accurately and in some cases even to improve the capacity of the process by operating at higher than nominal speeds.

In contrast with conventional applications operating with a direct-on-line (DOL) supply, a VSD makes smooth starting possible. This significantly reduces the stress on the motor and driven application. Smooth starting also means that the supply network will not be affected by high starting current transients, a fact that can be taken into account in the design of the network.

The use of ABB industrial drives together with Process performance motors usually provides substantial energy savings as the speed and therefore the power required by the process can be optimized.

Process performance motors are designed for both DOL and variable speed operation. A wide range of options is available, so motors can be adapted to the most demanding applications.

When selecting Process performance motors for VSDs, the following points must be taken into consideration.

1. Dimensioning

The voltage (or current) fed by the VSD is not purely sinusoidal. This may increase motor losses, vibration, and noise level. Further, a change in the distribution of losses may affect the motor's temperature rise. In each case, the motor must be correctly sized according to the instructions supplied for the frequency converter.

ABB's DriveSize program utilizes dimensioning rules that are based on comprehensive motor and drive type tests. Please use DriveSize for selecting the correct motor and drive combination for a desired load profile.

In case of manual dimensioning, note that the loadability (or load capacity) curves provided in this catalog and in the respective manuals are indicative only. Values for a specific motor and drive are available on request.

In addition to thermal dimensioning, an adequate torque margin must be maintained for stability. The maximum torque of the motor must be at least 30 % higher than the load torque over the whole duty range.

Voltage drop in the supply cable must also be taken into consideration, especially in cases where long supply cables are needed.

2. Operating speed, vibrations and shaft seals

Process performance motors are designed to work over a wide speed range and also at significantly higher than nominal speeds. The maximum speeds can be found on motor rating plates or in DriveSize. In addition to motor speed, make sure that the maximum or critical speed of the entire application is not exceeded.

If a particularly low level of vibration is required, motors with improved balancing (variant code 417) should be used.

In high speed applications, the use of labyrinth seals (variant code 783) instead of V rings should be considered.

Guideline maximum speed values for Process performance motors are shown in Table 1.

Motor size	Maximum speed, r/min	
	2-pole motors	4-pole motors
71-80	6000	4500
90-100	6000	6000
112-200	4500	4500
225-250	3600	3600
280	3600	2600
315	3600	2300
355 SM, ML, LKA	3600	2000
355 LKB	3600	2000
400	3600	1800
450	3000	1800

Table 1. Guideline maximum speed values for Process performance cast iron motors.

3. Ventilation

When the motor is operated at low speeds, the cooling capacity of the fan decreases, which again reduces the motor's load capacity. A separate constant speed fan (variant codes 183, 422, 514) can be used to increase cooling capacity.

At high speeds, the use of metal fans (variant code 068) instead of plastic ones should be considered. If a low noise level is required, unidirectional low-noise fans (variant codes 044 and 045) are recommended.

4. Lubrication

In variable speed applications, bearing temperature varies as a function of speed and motor load. In such cases, the most accurate relubrication intervals can be obtained by measuring the bearing temperature under normal operating conditions. If the measured temperature is higher than +80 °C, the relubrication intervals specified on the lubrication plate or in the maintenance manual must be shortened, or lubricants suitable for high operating temperatures must be used. See ABB low voltage motor manual.

In case of continuous operation at very low speeds and at very low temperatures (below -20 °C), the lubrication properties of standard greases may not be sufficient, and special greases with additives are needed.

Operating temperatures also affect bearing life. When motors are equipped with sealed bearings, that is, bearings greased for life, it must be noted that if the operating temperature differs from the design temperature, the bearing life will also be different. More information on bearing lifetimes can be found in section Mechanical design of this catalog and in the relevant manuals.

The use of so-called conductive greases for elimination of bearing currents is not recommended because of their poor lubrication characteristics and low conductivity.

5. Winding insulation

To ensure that motors operate reliably, the effects of non-sinusoidal output voltages from the converter must be taken into consideration when selecting the correct insulation system for the motor and output filters for the converter.

Insulation and filters must be selected according to Table 2.

Winding insulation and filters required	
UN ≤ 500 V	Standard insulation
UN ≤ 600 V	Standard insulation + dU/dt filters OR Special insulation (variant code 405)
UN ≤ 690 V	Special insulation (variant code 405) AND dU/dt-filters at converter output
600 V < UN ≤ 690 V cable length > 150 m	Special insulation (variant code 405)

Table 2. Selection of motor winding insulation and converter output filters

For more information on dU/dt filters, see the relevant ABB drives catalogs.

For other converters and cases where the guidelines shown in Table 2 cannot be applied, selection must be based on the voltages present at motor terminals. The allowed phase-to-ground voltage peaks at motor terminals:

- 1300 V peak: standard insulation
- 1800 V peak: special insulation, variant code 405

The maximum allowed phase-to-phase voltage peaks at the motor terminals as a function of pulse rise time are shown in Figure 1. The higher curve, Special insulation, applies to motors with special winding insulation for frequency converter supply, variant code 405. Standard insulation applies to motors with standard design.

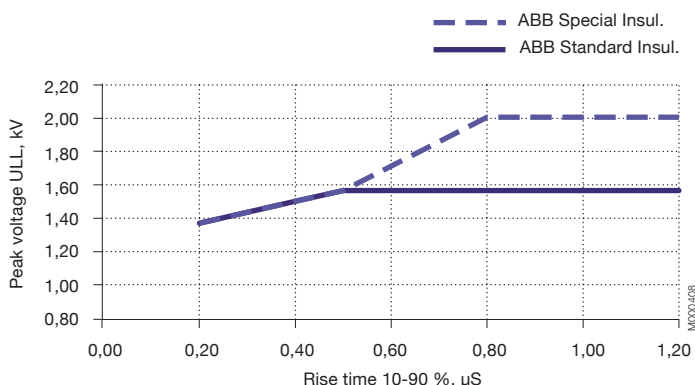

Figure 1. Maximum allowed phase-to-phase voltage peaks at motor terminals, as a function pulse rise time

6. Bearing currents

Bearing voltages and currents must be avoided in all motors to ensure reliable operation of the entire application. With ACS800 or ACS550 drives and uncontrolled DC voltage, insulated bearings (variant code 701) and/or properly dimensioned filters at the converter must be used, as indicated in Table 3. For information on other converter types, contact ABB Sales. When ordering, clearly state which alternative will be used.

Nominal power (PN) and / or Frame size (IEC)	Precautionary measures
$P_N < 100$ kW	No action needed
$P_N \geq 100$ kW OR $IEC 315 \leq$ Frame size \leq IEC 355	Insulated non-drive end bearing
$P_N \geq 350$ kW OR $IEC 400 \leq$ Frame size \leq IEC 450	Insulated non-drive end bearing AND Common mode filter at the converter

Table 3. Precautionary measures to avoid bearing currents in variable speed drives

For more information on bearing currents, see “Technical guide No. 5, Bearing currents in modern AC drive systems”.

Common mode filters

Common mode filters reduce common mode currents and so decrease the risk of bearing currents. Common mode filters do not significantly affect the phase of main voltages on motor terminals. For more information, see ABB drives catalogs.

Insulated bearings

ABB uses bearings with insulated inner or outer races. Hybrid bearings, that is, bearings with non-conductive ceramic rolling elements, can also be used in special applications.

7. Cabling, grounding, and EMC

The use of a variable speed drive sets higher demands on the cabling and grounding of the drive system. The motor must be cabled using shielded symmetrical cables and cable glands providing 360° bonding (EMC glands, variant code 704). For motors up to 30 kW, asymmetrical cables can be used, but shielded cables are always recommended, especially if there are sensitive components in the driven application.

For motor sizes IEC 280 and above, additional potential equalization is needed between the motor frame and the machinery, unless the motor and the driven machine are installed on a common steel base. When a steel base is used for potential equalization, high frequency conductivity of the connection must be checked.

To meet EMC requirements, special EMC cables must be used in addition to appropriate cable gland mounting with special earthing pieces. Refer to ABB drives manuals for more information.

8. Motor loadability with frequency converter drives

The loadability curves shown in Figures 2 and 3 are indicative guidelines and do not present exact values. These loadability curves can also be used for preliminary dimensioning of motors used at frequency converter duty, but it must be noted that the harmonic content and control algorithms vary between frequency converters, so the motor temperature rise will also be different.

The curves show the maximum continuous load torque as a function of frequency (speed), which results in the same temperature rise as operation with the rated sinusoidal supply at nominal frequency and full rated load.

Normally, Process performance motors operate according to class B temperature rise. For these motors, dimensioning should be done according to temperature rise B curve, or the motor can be slightly overloaded. In other words, it can be dimensioned according to temperature rise F curve.

However, if only class F temperature rise with a sinusoidal supply is indicated for the motor in the technical data section, dimensioning must be done according to the temperature rise curve B.

If the motor is loaded according the temperature rise F curve, it will be necessary to check the temperature rise in other parts of the motor and ensure that the lubrication intervals and grease type are still appropriate.

Temperature rise B

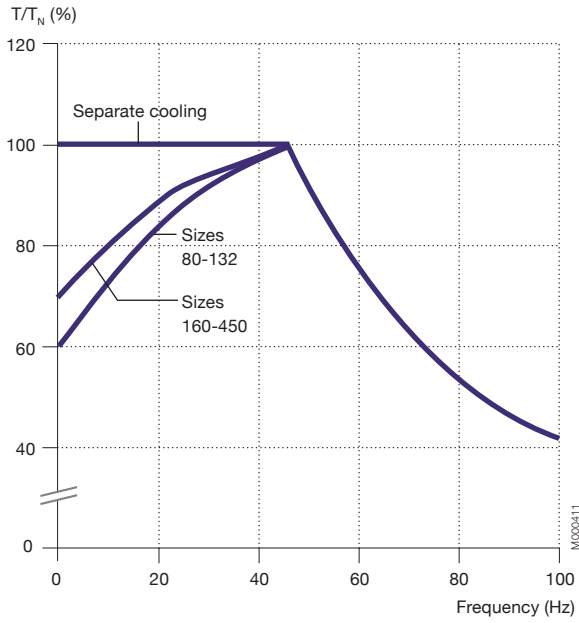

Temperature rise F

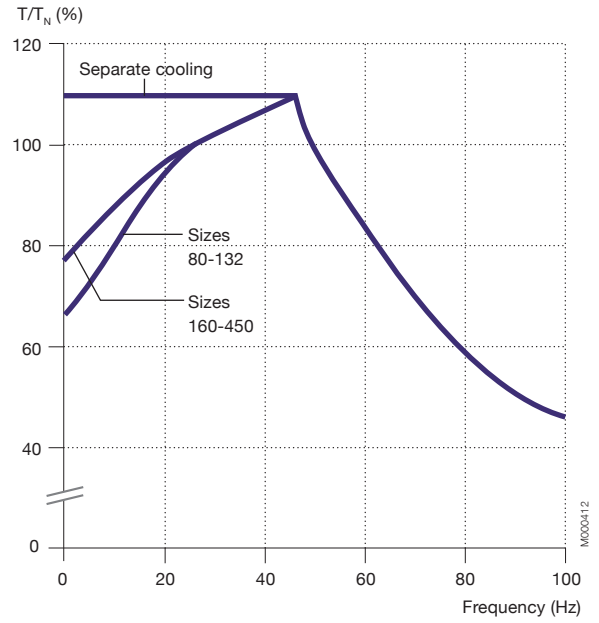
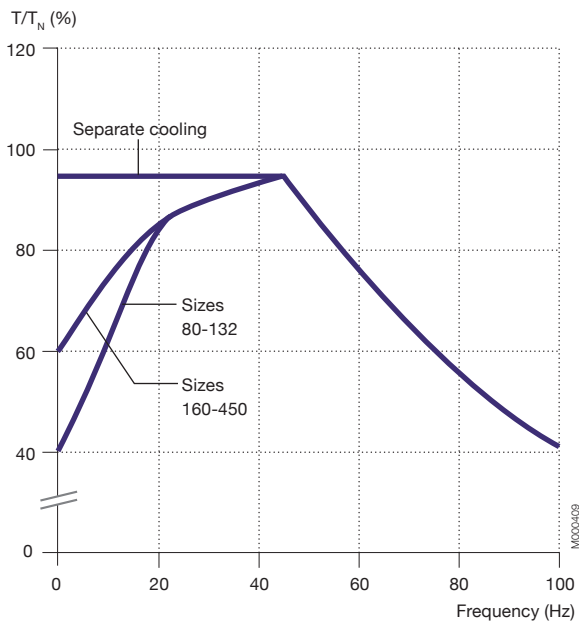

Figure 2. Loadability curves for frequency converters with DTC control

Temperature rise B



Temperature rise F

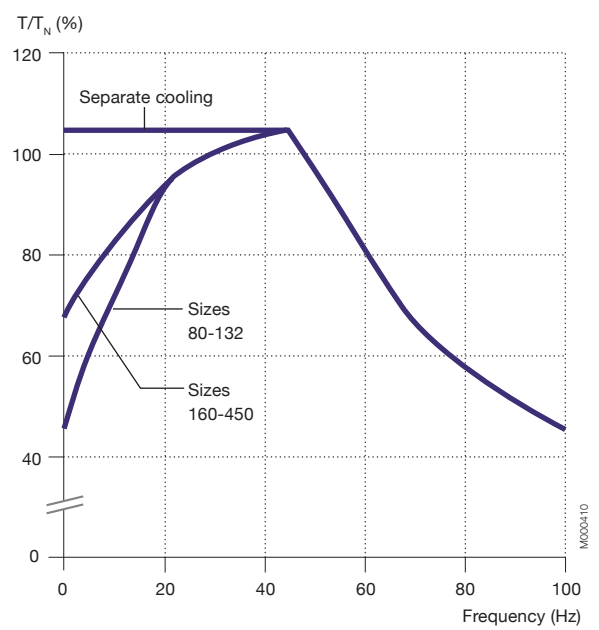

Figure 3. Loadability curves for other frequency converters

For further information, please contact ABB.

Process performance cast iron motors

Totally enclosed squirrel cage three phase low voltage motors

Sizes 71 to 450, 0.09 to 1000 kW

Ordering information	18
Rating plates	19
Technical data IE2 AU MEPS	20
3000 r/min motors	20
1500 r/min motors	22
1000 r/min motors	24
750 r/min motors	26
600 and 500 r/min motors	27
Technical data IE3 AU high efficiency (HE) MEPS	28
3000 r/min motors	28
1500 r/min motors	29
1000 r/min motors	30
Variant codes	31
Mechanical design	38
Motor frame, drain holes and heating elements	38
Bearings	39
Terminal box	49
Dimension drawings	57
Accessories	71
Built-in brake	71
Separate cooling	73
Silencer	74
Slide rails	75
Cast iron motors in brief	77
Motor construction	80



Ordering information

When placing an order, specify motor type, size and product code according to the following example.

Example	
Motor type	M3BP 160 MLC
Pole number	2
Mounting arrangement (IM-code)	IM B3 (IM 1001)
Rated output	18.5 kW
Product code	3GBP161033-ADG
Variant codes if needed	

Explanation of the product code

Motor type	Motor size	Product code	Mounting arrangement code, Voltage and frequency code, Generation code	Variant codes
M3BP	160MLC	3GBP 161 033	- ADG	003, etc.
		1 2 3 4 5 6 7 8 9 10 11 12 13 14		

Positions 1 to 4

3GBP: Totally enclosed fan cooled squirrel cage motor with cast iron frame

Positions 5 and 6

IEC size

71:	71
80:	80
90:	90
10:	100
12:	112
13:	132
16:	160
18:	180
20:	200
22:	225
25:	250
28:	280
31:	315
35:	355
40:	400
45:	450

Position 7

Speed (Pole pairs)

1:	2 poles
2:	4 poles
3:	6 poles
4:	8 poles
5:	10 poles
6:	12 poles
7:	> 12 poles
8:	Two-speed motors for fan drive motors for constant torque
9:	Multi-speed motors, two-speed

Positions 8 to 10

Serial number

Position 11

- (dash)

Position 12 (marked with black dot in data tables)

Mounting arrangement

A:	Foot-mounted, top-mounted terminal box
R:	Foot-mounted, terminal box RHS seen from D-end
L:	Foot-mounted, terminal box LHS seen from D-end
B:	Flange-mounted, large flange
C:	Flange-mounted, small flange (sizes 71 to 112)
H:	Foot- and flange-mounted, terminal box top-mounted
J:	Foot- and flange-mounted, small flange with tapped holes
S:	Foot- and flange-mounted, terminal box RHS seen from D-end
T:	Foot- and flange-mounted, terminal box LHS seen from D-end
V:	Flange-mounted, special flange
F:	Foot- and flange-mounted. Special flange

Position 13 (marked with black dot in data tables)

Voltage and frequency

Single-speed motors

B:	380 VΔ 50 Hz
D:	400 VΔ, 415 VΔ, 690 VY 50 Hz
E:	500 VΔ 50 Hz
F:	500 VY 50 Hz
S:	230 VΔ, 400 VY, 415 VY 50 Hz
T:	660 VΔ 50 Hz
U:	690 VΔ 50 Hz
X:	Other rated voltage, connection or frequency, 690 V maximum

Two-speed motors

A:	220 V 50 Hz
B:	380 V 50 Hz
D:	400 V 50 Hz
E:	500 V 50 Hz
S:	230 V 50 Hz
X:	Other rated voltage, connection or frequency, 690 V maximum

Remark: For voltage code X the variant code "209 Non-standard voltage or frequency (special winding)" must be ordered.

Position 14

Generation code

A, B, C...G...K: The product code must be, if needed, followed by variant codes.

Rating plates

The motor's main rating plate shows the motor's performance values with various connections at nominal speed. The rating plate also shows the efficiency level (IE2, IE3, or IE4), year of manufacture, and the lowest nominal efficiency at 100, 75, and 50 % nominal load.

The lubrication plate specifies regreasing amount, regreasing interval in hours - depending on the mounting position and ambient temperature - and types of lubricant recommended.

ABB					
Regreasing intervals in duty hours					
Bearings		6319/C3		6316/C3	
Amount of grease		55 g		40 g	
Mounting	Ambient temp.	1800 r/min	1500 r/min	1000 r/min	0-900 r/min
Hor	25	6500	8500	12500	16000
Hor	40	3250	4250	6250	8000
Vert	25	3250	4250	6250	8000
Vert	40	1630	2130	3130	4000
Do not exceed the motor max. speed					
The following or similar high performance grease can be used:					
Esso	Unirex N2 or N3		Shell	Albida EMS2	
Total	Multis Complex S2 A		Mobil	Mobilith SCH 100	
Kluber	Kluberplex BEM 41-132		FAG	Arconol TEMP110	
			1060392-1		
See respective "Motor Manual"					

Motor sizes 280 to 450, lubrication plate

CE IE2						
3 ~ Motor M3BP 315SMA 4 IMB3/IM1001						
2013				No.		
		Ins. cl. F		IP 55		
V	Hz	kW	r/min	A	cosφ	Duty
690 Y	50	110	1489	113	0.85	S1
400 D	50	110	1489	196	0.85	S1
415 D	50	110	1489	191	0.85	S1
IE2-95.2%(100%)-95.3%(75%)-94.9%(50%)						
Prod.code 3GBP312210-ADG543						
				Nmax 2300 r/min		
6319/C3		6316/C3		900 kg		
ABB IEC 60034-1						

Example of a standard motor rating plate

Technical data

IE2 cast iron motors according to AU MEPS, 3000 r/min

IP 55 - IC 411 - Insulation class F, temperature rise class B. IE2 efficiency class according to IEC 60034-30; 2008.

Output kW	Motor type	Product code	Speed r/min	Efficiency IEC 60034-2-1; 2007			Power factor cos φ	Current		Torque			Moment of inertia J = 1/4 GD ² kgm ²	Weight kg	Sound pressure level L _{PA} dB
				Full load 100%	3/4 load 75%	1/2 load 50%		I _N A	I _s /I _N	T _N Nm	T ₁ /T _N	T _b /T _N			
3000 r/min = 2 poles				415 V 50 Hz				CENELEC-design							
0.37 ⁴⁾	M3BP 71 MA	3GBP 071 321...B	2785	75.1	74.2	69.7	0.75	0.91	4.7	1.26	2.4	2.5	0.00039	11	58
0.55 ⁴⁾	M3BP 71 MB	3GBP 071 322...B	2829	78.1	77.9	74.9	0.76	1.28	4.7	1.86	2.6	2.7	0.00051	11	56
0.75	M3BP 80 MB	3GBP 081 441...B	2905	81.3	80.1	75.9	0.70	1.83	7.7	2.4	4.5	4.6	0.0010	16	57
1.1	M3BP 80 MC	3GBP 081 443...B	2865	80.9	80.0	77.4	0.78	2.4	7.9	3.6	3.1	3.9	0.0012	18	60
1.5	M3BP 90 SLB	3GBP 091 442...B	2900	83.0	83.1	81.1	0.88	2.8	7.9	4.9	2.7	2.8	0.00254	24	69
2.2	M3BP 90 SLC	3GBP 091 443...B	2895	84.0	84.7	83.6	0.88	4.1	7.3	7.2	2.0	2.7	0.0028	25	64
3	M3BP 100 LB	3GBP 101 442...B	2910	86.3	86.6	85.0	0.86	5.6	8.9	9.8	3.5	4.2	0.00528	36	68
4	M3BP 112 MC	3GBP 111 443...B	2860	84.6	86.3	86.8	0.93	7.0	6.4	13.3	2.5	3.1	0.0062	40	68
5.5	M3BP 132 SMB	3GBP 131 442...B	2870	87.0	87.5	86.5	0.90	9.7	7.4	18.3	2.2	2.9	0.0128	68	70
7.5	M3BP 132 SME	3GBP 131 445...B	2910	89.8	90.0	89.0	0.90	12.9	8.8	24.6	2.6	4.3	0.018	75	70
11	M3BP 160 MLA	3GBP 161 031...G	2945	90.7	91.1	90.2	0.87	19.3	8.0	35.6	2.6	3.3	0.044	127	69
15	M3BP 160 MLB	3GBP 161 036...G	2946	91.7	92.0	92.2	0.89	25.5	8.1	48.6	2.7	3.6	0.053	141	69
18.5	M3BP 160 MLC	3GBP 161 037...G	2946	92.0	92.7	92.3	0.88	31.7	8.0	59.9	3.1	3.6	0.063	170	69
22	M3BP 180 MLA	3GBP 181 031...G	2959	92.3	92.7	92.2	0.85	39.0	8.1	70.9	3.0	3.6	0.076	190	69
30	M3BP 200 MLA	3GBP 201 035...G	2962	93.2	93.7	93.4	0.89	50.3	8.3	96.7	3.0	3.4	0.18	283	72
37	M3BP 200 MLB	3GBP 201 036...G	2964	93.9	94.3	94.0	0.87	63.0	8.7	119	3.3	3.6	0.20	298	72
45	M3BP 225 SMA	3GBP 221 031...G	2965	93.3	93.5	92.7	0.87	77.1	7.1	144	2.7	2.7	0.24	347	74
55	M3BP 250 SMA	3GBP 251 031...G	2969	93.8	94.0	93.5	0.87	93.7	7.2	176	2.4	3.0	0.51	405	75
75 ²⁾	M3BP 280 SMA	3GBP 281 210...G	2977	94.1	93.8	92.5	0.88	126	8.3	240	2.3	3.2	0.80	625	77
75 ²⁾	M3BP 280 SMA	3GBP 281 210...G	2976	94.2	94.1	93.1	0.89	124	7.0	240	1.9	2.7	0.80	625	77
90 ²⁾	M3BP 280 SMB	3GBP 281 220...G	2975	94.6	94.4	93.5	0.88	150	8.1	288	2.3	3.1	0.90	665	77
110 ²⁾	M3BP 315 SMA	3GBP 311 210...G	2984	95.0	94.5	92.9	0.83	194	8.2	352	2.2	3.2	1.20	880	78
110 ²⁾	M3BP 315 SMB	3GBP 311 220...G	2978	94.7	94.5	93.5	0.91	177	6.2	352	1.7	2.5	1.40	940	78
132 ²⁾	M3BP 315 SMB	3GBP 311 220...G	2984	94.9	94.6	93.3	0.85	227	8.6	422	2.4	3.2	1.40	940	78
150 ²⁾	M3BP 315 SMC	3GBP 311 230...G	2985	95.6	95.3	94.2	0.87	250	8.5	479	2.7	3.4	1.70	1025	78
160 ²⁾	M3BP 315 SMC	3GBP 311 230...G	2983	95.4	95.2	94.2	0.87	268	8.6	512	2.5	3.2	1.70	1025	78
160	M3BP 355 SMA	3GBP 351 210...G	2980	96.1	95.9	95.1	0.91	254	6.1	512	1.6	2.6	3.00	1600	83
185 ²⁾	M3BP 315 MLA	3GBP 311 410...G	2984	95.9	95.7	94.8	0.88	304	8.9	592	3.0	3.5	2.10	1190	78
200 ²⁾	M3BP 315 MLA	3GBP 311 410...G	2982	95.8	95.7	94.9	0.89	326	8.3	640	2.8	3.2	2.10	1190	78
250 ²⁾	M3BP 355 SMA	3GBP 351 210...G	2985	95.7	95.4	94.4	0.88	412	8.2	800	2.3	3.5	3.00	1600	83
315 ²⁾	M3BP 355 SMB	3GBP 351 220...G	2982	95.7	95.7	95.0	0.89	514	7.6	1009	2.3	3.2	3.40	1680	83
355 ²⁾	M3BP 355 SMC	3GBP 351 230...G	2985	95.7	95.7	95.0	0.88	586	7.9	1135	2.4	3.2	3.60	1750	83
400 ²⁾	M3BP 355 MLA	3GBP 351 410...G	2984	96.9	96.6	95.8	0.87	660	7.7	1280	2.5	3.1	4.10	2000	83
450 ²⁾	M3BP 355 MLB	3GBP 351 420...G	2985	97.1	97.0	96.3	0.90	716	8.6	1440	2.4	3.8	4.30	2080	83
500 ²⁾	M3BP 355 LKA	3GBP 351 810...G	2983	97.0	96.9	96.4	0.90	796	8.1	1601	2.2	4.2	4.80	2320	83
560 ²⁾	M3BP 355 LKB	3GBP 351 820...G	2984	97.1	97.0	96.4	0.90	891	8.6	1792	2.4	4.4	5.20	2460	83
560 ³⁾	M3BP 400 LA	3GBP 401 510...G	2989	97.2	97.1	96.5	0.88	910	8.4	1789	2.3	3.7	7.90	2950	82
560 ³⁾	M3BP 400 LKA	3GBP 401 810...G	2989	97.2	97.1	96.5	0.88	910	8.4	1789	2.3	3.7	7.90	2950	82
630 ³⁾	M3BP 400 LB	3GBP 401 520...G	2988	97.4	97.4	96.7	0.88	1022	8.4	2013	2.3	3.6	8.20	3050	82
630 ³⁾	M3BP 400 LKB	3GBP 401 820...G	2988	97.4	97.4	96.7	0.88	1022	8.4	2013	2.3	3.6	8.20	3050	82
710 ³⁾	M3BP 400 LC	3GBP 401 530...G	2988	97.5	97.4	96.9	0.89	1138	8.4	2269	2.8	3.6	9.30	3300	82
710 ³⁾	M3BP 400 LKC	3GBP 401 830...G	2988	97.5	97.4	96.9	0.89	1138	8.4	2269	2.8	3.6	9.30	3300	82
800 ¹⁾³⁾	M3BP 450 LA	3GBP 451 510...G	2991	97.2	97.0	96.3	0.87	1316	8.5	2554	1.4	3.4	12.50	4000	85
900 ¹⁾³⁾	M3BP 450 LB	3GBP 451 520...G	2991	97.3	97.2	96.5	0.88	1462	8.4	2873	1.6	3.3	14.00	4200	85

¹⁾ Temperature rise class F

²⁾ -3dB(A) sound pressure level reduction with unidirectional fan construction. Direction of rotation must be stated when ordering, see variant codes 044 and 045

³⁾ Unidirectional fan, variant code 044 or 045 is mandatory

⁴⁾ Output powers below 0.75 kW and above 185 kW are not subject to Australian MEPS requirement
Efficiency values are given according to IEC 60034-2 - 1; 2007

Technical data

IE2 cast iron motors according to AU MEPS, 3000 r/min

IP 55 - IC 411 - Insulation class F, temperature rise class B. IE2 efficiency class according to IEC 60034-30; 2008.

Output kW	Motor type	Product code	Speed r/min	Efficiency IEC 60034-2-1; 2007			Power factor cos φ	Current		Torque			Moment of inertia J = 1/4 GD ² kgm ²	Weight kg	Sound pressure level L _{PA} dB
				Full load 100%	3/4 load 75%	1/2 load 50%		I _N A	I _s / I _N	T _N Nm	T _i / T _N	T _p / T _N			
3000 r/min = 2 poles				415 V 50 Hz				High-output design							
22	M3BP 160 MLD	3GBP 161 034-...G	2951	92.1	92.7	92.4	0.87	38.1	8.5	71.1	3.4	3.9	0.063	170	69
27	M3BP 160 MLE	3GBP 161 035-...G	2949	92.5	93.1	92.9	0.87	46.6	9.3	87.4	3.7	4.1	0.072	184	69
30	M3BP 180 MLB	3GBP 181 032-...G	2953	92.2	92.9	92.6	0.87	52.0	8.3	97	3.0	3.6	0.092	208	69
45	M3BP 200 MLC	3GBP 201 033-...G	2962	93.7	94.2	93.9	0.87	76.7	8.5	145	3.3	3.6	0.20	298	72
55 ¹⁾	M3BP 200 MLD	3GBP 201 034-...G	2958	93.7	94.1	93.8	0.88	92.7	8.4	177	3.2	3.6	0.22	314	72
55	M3BP 225 SMB	3GBP 221 032-...G	2965	93.8	94.1	93.6	0.87	93.7	7.0	177	2.6	2.7	0.27	369	74
75 ¹⁾	M3BP 225 SMC	3GBP 221 033-...G	2970	94.7	94.7	94.1	0.80	137	7.6	241	3.4	3.3	0.31	396	74
75	M3BP 250 SMB	3GBP 251 032-...G	2975	95.0	95.3	95.1	0.87	126	8.1	240	3.0	3.3	0.58	451	75
80 ¹⁾	M3BP 225 SMD	3GBP 221 034-...G	2967	94.2	94.4	93.6	0.84	140	7.5	257	3.2	3.1	0.33	410	74
90 ²⁾	M3BP 280 SMC	3GBP 281 230-...G	2974	94.7	94.7	94.0	0.91	145	6.8	288	2.0	2.6	1.15	725	77
90 ¹⁾	M3BP 250 SMC	3GBP 251 033-...G	2973	95.6	95.8	95.6	0.89	147	8.1	289	2.8	3.3	0.64	487	75
110 ²⁾	M3BP 280 SMC	3GBP 281 230-...G	2973	94.7	94.7	93.8	0.89	181	8.5	353	2.6	3.2	1.15	725	77
132	M3BP 280 MLA	3GBP 281 410-...G	2977	95.5	95.5	94.9	0.89	216	8.1	423	2.7	3.2	1.40	840	81
160	M3BP 280 MLB	3GBP 281 420-...G	2976	95.9	96.0	95.4	0.90	257	8.5	513	3.1	3.2	1.55	890	81
250 ²⁾⁴⁾	M3BP 315 LKA	3GBP 311 810-...G	2982	95.7	95.7	95.1	0.89	408	8.8	801	3.0	3.2	2.65	1440	78
315 ¹⁾²⁾⁴⁾	M3BP 315 LKC	3GBP 311 830-...G	2983	95.7	95.7	95.3	0.89	514	9.5	1009	3.4	3.4	3.30	1630	78

¹⁾ Temperature rise class F

²⁾ -3dB(A) sound pressure level reduction with unidirectional fan construction. Direction of rotation must be stated when ordering, see variant codes 044 and 045

⁴⁾ Output powers below 0.75 kW and above 185 kW are not subject to Australian MEPS requirement

Efficiency values are given according to IEC 60034-2 - 1; 2007

Technical data

IE2 cast iron motors according to AU MEPS, 1500 r/min

IP 55 - IC 411 - Insulation class F, temperature rise class B. IE2 efficiency class according to IEC 60034-30; 2008.

Output kW	Motor type	Product code	Speed r/min	Efficiency IEC 60034-2-1; 2007			Power factor cos φ	Current		Torque			Moment of inertia J = 1/4 GD ² kgm ²	Weight kg	Sound pressure level L _{PA} dB
				Full load 100%	3/4 load 75%	1/2 load 50%		I _N A	I _s / I _N	T _N Nm	T ₁ / T _N	T _b / T _N			
1500 r/min = 4 poles				415 V 50 Hz				CENELEC-design							
0.25 ⁴⁾	M3BP 71 MA	3GBP 072 321...B	1390	69.2	69.8	66.7	0.78	0.64	3.8	1.71	2.1	2.2	0.00074	10	45
0.37 ⁴⁾	M3BP 71 MB	3GBP 072 322...B	1410	73.3	74.5	72.9	0.78	0.90	4.5	2.5	1.8	2.3	0.00088	11	45
0.55 ⁴⁾	M3BP 80 MA	3GBP 082 321...B	1420	72.7	71.0	65.7	0.69	1.52	5.0	3.6	2.1	3.0	0.0014	15	45
0.75	M3BP 80 MD	3GBP 082 444...B	1435	80.8	80.5	77.4	0.70	1.84	6.4	4.9	3.4	3.2	0.0021	17	50
1.1	M3BP 90 SLC	3GBP 092 444...B	1435	82.9	82.6	80.4	0.80	2.3	6.5	7.3	2.9	3.3	0.0049	26	56
1.5	M3BP 90 SLD	3GBP 092 445...B	1445	83.3	83.7	80.5	0.74	3.3	5.1	9.9	4.0	4.7	0.0054	27	56
2.2	M3BP 100 LC	3GBP 102 443...B	1455	85.6	84.5	82.2	0.78	4.5	6.6	14.4	3.2	3.9	0.0095	36	56
3	M3BP 100 LE	3GBP 102 445...B	1450	86.1	86.7	85.7	0.83	5.8	7.2	19.7	2.9	3.6	0.0011	38	58
4	M3BP 112 MB	3GBP 112 442...B	1435	85.7	87.0	86.7	0.81	8.0	7.0	26.6	3.1	3.5	0.013	44	59
5.5	M3BP 132 SMB	3GBP 132 442...B	1460	89.0	89.3	88.3	0.82	10.4	6.0	35.9	1.8	2.5	0.033	70	66
7.5	M3BP 132 SMC	3GBP 132 443...B	1455	89.1	89.6	88.9	0.82	14.2	6.1	49.2	1.7	2.5	0.037	73	64
11	M3BP 160 MLA	3GBP 162 031...G	1475	90.2	90.9	90.5	0.83	20.4	7.3	71.2	2.4	3.0	0.081	135	62
15	M3BP 160 MLB	3GBP 162 032...G	1473	90.9	91.6	91.2	0.81	28.3	7.5	97.2	2.8	3.2	0.099	165	62
18.5	M3BP 180 MLA	3GBP 182 031...G	1480	91.6	92.3	92.0	0.80	35.1	7.7	119	2.8	3.1	0.17	205	62
22	M3BP 180 MLB	3GBP 182 032...G	1480	92.0	92.7	92.5	0.82	40.5	7.8	141	2.9	3.2	0.20	222	62
30	M3BP 200 MLA	3GBP 202 031...G	1482	93.7	94.2	94.1	0.83	53.6	7.9	193	3.0	3.3	0.31	291	63
37	M3BP 225 SMA	3GBP 222 031...G	1481	93.7	94.0	93.6	0.80	68.6	7.3	238	2.9	3.1	0.36	324	66
45	M3BP 225 SMB	3GBP 222 032...G	1484	94.0	94.2	93.7	0.82	81.2	8.0	289	3.0	3.5	0.44	356	66
55	M3BP 250 SMA	3GBP 252 031...G	1481	94.1	94.3	93.9	0.82	99.1	7.5	354	2.8	3.2	0.77	414	67
75	M3BP 280 SMA	3GBP 282 210...G	1485	94.7	94.8	94.1	0.84	131	7.2	482	2.7	3.0	1.25	625	68
75	M3BP 280 SMA	3GBP 282 210...G	1484	94.2	94.5	94.0	0.85	130	6.8	482	2.4	2.7	1.25	625	68
90	M3BP 315 SMA	3GBP 312 210...G	1486	94.7	94.9	94.3	0.88	150	6.2	578	1.6	2.1	2.30	900	70
90	M3BP 280 SMB	3GBP 282 220...G	1484	95.1	95.3	94.8	0.84	156	7.7	579	2.7	2.9	1.50	665	68
110	M3BP 315 SMA	3GBP 312 210...G	1489	95.2	95.2	94.4	0.84	191	7.9	705	2.2	2.7	2.30	900	70
110	M3BP 315 SMA	3GBP 312 210...G	1488	94.6	94.7	94.1	0.85	190	6.9	705	1.9	2.4	2.30	900	70
132	M3BP 315 SMB	3GBP 312 220...G	1488	95.2	95.2	94.5	0.84	230	7.8	847	2.5	2.9	2.60	960	70
132	M3BP 315 SMB	3GBP 312 220...G	1487	95.3	95.5	95.0	0.87	221	6.7	847	2.2	2.5	2.60	960	70
150	M3BP 315 SMC	3GBP 312 230...G	1488	95.4	95.4	94.6	0.83	263	8.2	962	2.8	3.3	2.90	1000	70
160	M3BP 315 SMC	3GBP 312 230...G	1489	95.7	95.8	95.1	0.84	277	7.7	1026	2.6	3.1	2.90	1000	70
160	M3BP 315 MLA	3GBP 312 410...G	1486	95.4	95.6	95.2	0.88	265	6.9	1028	2.3	2.8	3.50	1160	70
185	M3BP 315 MLA	3GBP 312 410...G	1489	95.8	95.8	95.2	0.84	319	8.3	1186	2.9	3.4	3.50	1160	70
200 ⁴⁾	M3BP 315 MLA	3GBP 312 410...G	1488	95.6	95.6	95.2	0.85	342	7.7	1285	2.7	3.1	3.50	1160	70
250 ⁴⁾	M3BP 355 SMA	3GBP 352 210...G	1489	95.9	95.9	95.4	0.85	426	7.6	1604	2.5	2.9	5.90	1610	74
315 ⁴⁾	M3BP 355 SMB	3GBP 352 220...G	1489	95.9	95.9	95.5	0.85	537	7.8	2021	2.5	3.0	6.90	1780	74
355 ⁴⁾	M3BP 355 SMC	3GBP 352 230...G	1488	95.9	95.9	95.6	0.85	605	7.2	2279	2.6	2.9	7.20	1820	78
400 ⁴⁾	M3BP 355 MLA	3GBP 352 410...G	1490	96.3	96.3	95.8	0.84	687	7.3	2563	2.5	2.8	8.40	2140	78
450 ⁴⁾	M3BP 355 MLB	3GBP 352 420...G	1491	96.8	96.7	96.1	0.84	769	7.3	2882	2.5	3.1	8.40	2140	78
500 ⁴⁾	M3BP 355 LKA	3GBP 352 810...G	1491	97.0	97.0	96.3	0.85	843	7.3	3202	2.2	3.3	10.00	2500	78
560 ¹⁴⁾	M3BP 355 LKB	3GBP 352 820...G	1491	96.8	96.8	96.3	0.84	958	7.8	3586	2.8	2.9	10.60	2600	78
560 ⁴⁾	M3BP 400 LA	3GBP 402 510...G	1492	96.8	96.7	96.1	0.84	958	7.8	3584	2.6	3.1	15.00	3200	78
560 ⁴⁾	M3BP 400 LKA	3GBP 402 810...G	1492	96.8	96.7	96.1	0.84	958	7.8	3586	2.6	3.1	15.00	3200	78
560 ⁴⁾	M3BP 400 LKA	3GBP 402 810...G	1492	96.8	96.7	96.1	0.84	958	7.8	3584	2.6	3.1	15.00	3200	78
630 ⁴⁾	M3BP 400 LB	3GBP 402 520...G	1492	97.0	97.0	96.4	0.86	1050	8.2	4032	2.4	3.2	16.00	3300	78
630 ⁴⁾	M3BP 400 LKB	3GBP 402 820...G	1492	97.0	97.0	96.4	0.86	1050	8.2	4034	2.4	3.2	16.00	3300	78
630 ⁴⁾	M3BP 400 LKB	3GBP 402 820...G	1492	97.0	97.0	96.4	0.86	1050	8.2	4032	2.4	3.2	16.00	3300	78

⁴⁾ Output powers below 0.75 kW and above 185 kW are not subject to Australian MEPS requirement
Efficiency values are given according to IEC 60034-2 - 1; 2007

Technical data

IE2 cast iron motors according to AU MEPS, 1500 r/min

IP 55 - IC 411 - Insulation class F, temperature rise class B. IE2 efficiency class according to IEC 60034-30; 2008.

Output kW	Motor type	Product code	Speed r/min	Efficiency IEC 60034-2-1; 2007			Power factor cos φ	Current		Torque			Moment of inertia J = 1/4 GD ² kgm ²	Weight kg	Sound pressure level L _{PA} dB
				Full load 100%	3/4 load 75%	1/2 load 50%		I _N A	I _s / I _N	T _N Nm	T _i / T _N	T _p / T _N			
1500 r/min = 4 poles				415 V 50 Hz				CENELEC-design							
710 ⁴⁾	M3BP 400 LC	3GBP 402 530-...G	1492	97.1	97.0	96.5	0.84	1211	8.2	4544	2.6	3.2	17.00	3400	78
710 ⁴⁾	M3BP 400 LKC	3GBP 402 830-...G	1492	97.1	97.0	96.5	0.84	1211	8.2	4547	2.6	3.2	17.00	3400	78
710 ⁴⁾	M3BP 400 LKC	3GBP 402 830-...G	1492	97.1	97.0	96.5	0.84	1211	8.2	4544	2.6	3.2	17.00	3400	78
800 ⁴⁾	M3BP 450 LA	3GBP 452 510-...G	1492	96.9	96.8	96.1	0.85	1351	7.5	5120	1.4	3.0	23.00	4050	85
900 ⁴⁾	M3BP 450 LB	3GBP 452 520-...G	1492	97.1	97.1	96.4	0.85	1517	7.5	5760	1.4	3.0	25.00	4350	85
1000 ⁴⁾	M3BP 450 LC	3GBP 452 530-...G	1492	97.2	97.2	96.6	0.85	1683	7.3	6400	1.4	2.9	30.00	4700	85
1500 r/min = 4 poles				415 V 50 Hz				High-output design							
18.5	M3BP 160 MLC	3GBP 162 033-...G	1473	91.2	91.8	91.5	0.81	34.8	7.1	119	3.3	3.5	0.110	173	62
22	M3BP 160 MLD	3GBP 162 034-...G	1470	91.2	92.0	92.1	0.84	39.9	7.3	142	2.7	3.1	0.13	187	62
30 ¹⁾	M3BP 180 MLC	3GBP 182 033-...G	1479	92.0	92.7	92.6	0.82	55.3	7.7	193	2.9	3.2	0.22	235	62
37	M3BP 200 MLB	3GBP 202 032-...G	1481	93.6	94.2	94.2	0.84	65.4	7.6	238	2.8	3.2	0.34	307	63
45	M3BP 200 MLC	3GBP 202 033-...G	1480	93.2	93.8	93.6	0.80	83.9	7.8	290	3.2	3.5	0.37	319	63
55	M3BP 225 SMC	3GBP 222 033-...G	1480	93.9	94.3	94.0	0.83	98.1	7.8	354	3.2	3.3	0.47	370	66
64	M3BP 225 SMD	3GBP 222 034-...G	1478	93.8	94.0	93.5	0.80	118	8.4	413	3.6	3.6	0.54	399	66
75 ¹⁾	M3BP 250 SMB	3GBP 252 032-...G	1479	94.6	95.0	95.0	0.83	132	7.6	484	3.0	3.4	0.87	450	67
90 ¹⁾	M3BP 250 SMC	3GBP 252 033-...G	1481	94.6	95.0	94.7	0.81	163	7.7	580	3.4	3.6	0.94	478	67
110	M3BP 280 SMC	3GBP 282 230-...G	1485	95.6	95.7	95.2	0.84	190	8.0	707	3.0	3.2	1.85	725	68
132	M3BP 280 MLA	3GBP 282 410-...G	1484	95.5	95.7	95.3	0.85	226	7.2	849	2.9	3.1	2.30	840	75
160	M3BP 280 MLB	3GBP 282 420-...G	1484	95.6	95.8	95.5	0.83	278	7.7	1029	3.1	3.1	2.50	890	75
250 ⁴⁾	M3BP 315 LKA	3GBP 312 810-...G	1488	95.8	95.8	95.2	0.85	427	7.9	1605	2.7	3.1	4.40	1410	78
280 ⁴⁾	M3BP 315 LKB	3GBP 312 820-...G	1488	95.8	95.9	95.3	0.86	472	8.1	1798	2.8	3.3	5.00	1520	78
315 ⁴⁾	M3BP 315 LKC	3GBP 312 830-...G	1489	95.8	95.8	95.2	0.85	538	8.3	2021	2.8	3.4	5.50	1600	78

¹⁾ Temperature rise class F

⁴⁾ Output powers below 0.75 kW and above 185 kW are not subject to Australian MEPS requirement
Efficiency values are given according to IEC 60034-2 - 1; 2007

Technical data

IE2 cast iron motors according to AU MEPS, 1000 r/min

IP 55 - IC 411 - Insulation class F, temperature rise class B. IE2 efficiency class according to IEC 60034-30; 2008.

Output kW	Motor type	Product code	Speed r/min	Efficiency IEC 60034-2-1; 2007			Power factor cos φ	Current		Torque			Moment of inertia J = 1/4 GD ² kgm ²	Weight kg	Sound pressure level L _{PA} dB
				Full load 100%	3/4 load 75%	1/2 load 50%		I _N A	I _s /I _N	T _N Nm	T _l /T _N	T _b /T _N			
1000 r/min = 6 poles				415 V 50 Hz				CENELEC-design							
0.18 ⁴⁾	M3BP 71 MA	3GBP 073 321...B	900	61.7	61.6	57.4	0.72	0.56	3.1	1.9	2.1	2.2	0.00089	10	42
0.25 ⁴⁾	M3BP 71 MB	3GBP 073 322...B	905	66.9	65.8	60.4	0.65	0.79	3.5	2.6	2.4	2.5	0.0011	12	42
0.37 ⁴⁾	M3BP 80 MA	3GBP 083 321...B	925	70.7	69.9	65.2	0.65	1.12	3.7	3.8	1.9	2.4	0.0019	15	47
0.55 ⁴⁾	M3BP 80 MB	3GBP 083 322...B	925	72.9	73.0	69.6	0.69	1.52	3.9	5.6	1.9	2.4	0.0024	17	47
0.75	M3BP 90 SLC	3GBP 093 443...B	960	76.4	74.0	68.2	0.56	2.4	4.6	7.4	2.6	3.3	0.0049	25	44
1.1	M3BP 90 SLE	3GBP 093 444...B	945	80.1	80.4	78.0	0.69	2.7	4.3	11.1	2.4	2.9	0.0054	28	44
1.5	M3BP 100 L	3GBP 103 442...B	955	81.2	81.4	79.2	0.69	3.7	4.2	14.9	1.6	2.2	0.0087	37	49
2.2	M3BP 112 MB	3GBP 113 442...B	955	82.8	82.7	80.1	0.65	5.6	5.1	21.9	2.6	3.1	0.013	44	66
3	M3BP 132 SMB	3GBP 133 441...B	975	84.1	83.7	81.2	0.71	6.9	6.3	29.3	2.6	3.6	0.033	69	57
4	M3BP 132 SMC	3GBP 133 442...B	965	85.3	85.6	84.0	0.70	9.3	4.8	39.5	1.4	2.4	0.033	69	57
5.5	M3BP 132 SMF	3GBP 133 444...B	965	85.6	86.5	85.5	0.72	12.4	5.2	54.4	2.2	3.3	0.049	86	57
7.5	M3BP 160 MLA	3GBP 163 031...G	981	88.6	89.2	88.7	0.75	15.7	7.8	73.0	1.9	3.4	0.087	134	59
11	M3BP 160 MLB	3GBP 163 032...G	980	89.4	90.1	89.7	0.77	22.2	8.0	107	2.1	3.2	0.11	172	59
15	M3BP 180 MLA	3GBP 183 033...G	979	90.5	90.9	90.3	0.75	30.7	6.2	146	1.9	2.9	0.17	207	59
18.5	M3BP 200 MLA	3GBP 203 031...G	989	91.3	91.8	91.5	0.79	35.6	7.0	178	2.5	3.1	0.38	269	63
22	M3BP 200 MLB	3GBP 203 032...G	988	91.7	92.4	92.2	0.81	41.2	7.0	212	2.4	3.0	0.45	291	63
30	M3BP 225 SMA	3GBP 223 031...G	989	92.7	93.2	92.9	0.80	56.2	7.4	289	2.8	3.1	0.66	349	63
37	M3BP 250 SMA	3GBP 253 031...G	991	93.1	93.5	93.2	0.79	69.9	7.1	356	2.6	2.9	1.13	395	63
45	M3BP 280 SMA	3GBP 283 210...G	990	93.5	93.7	93.0	0.82	81.6	7.5	434	2.7	2.7	1.85	605	66
55	M3BP 280 SMB	3GBP 283 220...G	989	93.7	93.9	93.2	0.83	98.3	7.5	531	2.9	2.8	2.20	645	66
75	M3BP 315 SMA	3GBP 313 210...G	990	93.7	93.6	92.7	0.78	142	7.7	723	2.6	3.0	3.20	830	70
90	M3BP 315 SMB	3GBP 313 220...G	992	95.0	95.1	94.4	0.80	164	7.9	866	2.6	3.0	4.10	930	70
110	M3BP 315 SMC	3GBP 313 230...G	992	94.8	94.9	94.3	0.81	199	7.9	1058	2.7	3.1	4.90	1000	70
132	M3BP 315 MLA	3GBP 313 410...G	991	95.4	95.5	95.0	0.81	235	8.0	1271	2.9	3.2	5.80	1150	68
132	M3BP 315 MLB	3GBP 313 410...G	991	95.2	95.5	95.3	0.84	229	6.8	1271	2.4	2.7	5.80	1150	68
150	M3BP 355 SMA	3GBP 353 210...G	993	95.5	95.4	94.7	0.82	269	7.9	1442	2.3	3.1	7.90	1520	75
160	M3BP 355 SMC	3GBP 353 210...G	993	95.4	95.4	94.7	0.82	285	7.3	1538	2.2	2.8	7.90	1520	75
160	M3BP 355 SMA	3GBP 353 210...G	992	95.0	95.2	94.8	0.83	282	6.3	1540	1.8	2.3	7.90	1520	75
185	M3BP 355 SMB	3GBP 353 220...G	994	95.7	95.6	94.9	0.82	330	8.2	1777	2.6	3.1	9.70	1680	75
200 ⁴⁾	M3BP 355 SMB	3GBP 353 220...G	994	95.7	95.7	95.0	0.83	350	7.5	1921	2.4	2.9	9.70	1680	75
250 ⁴⁾	M3BP 355 SMC	3GBP 353 230...G	994	95.7	95.7	95.0	0.81	448	8.0	2401	2.8	3.1	11.30	1820	75
315 ⁴⁾	M3BP 355 MLB	3GBP 353 420...G	993	95.7	95.7	95.0	0.82	558	7.6	3029	2.8	2.9	13.50	2180	75
355 ⁴⁾	M3BP 355 LKA	3GBP 353 810...G	993	95.7	95.6	94.9	0.81	637	8.2	3413	3.0	3.1	15.50	2500	75
400 ⁴⁾	M3BP 355 LKB	3GBP 353 820...G	993	96.0	96.0	95.3	0.81	715	7.7	3846	2.8	2.8	16.50	2600	75
400 ⁴⁾	M3BP 400 LA	3GBP 403 510...G	994	96.2	96.2	95.6	0.80	723	7.5	3842	2.5	2.9	17.00	2900	76
400 ⁴⁾	M3BP 400 LKA	3GBP 403 810...G	994	96.2	96.2	95.6	0.80	723	7.5	3842	2.5	2.9	17.00	2900	76
450 ⁴⁾	M3BP 400 LKB	3GBP 403 820...G	994	96.6	96.5	95.9	0.80	810	7.8	4323	2.6	3.0	20.50	3150	76
450 ⁴⁾	M3BP 400 LB 6	3GBP 403 520...G	994	96.6	96.5	95.9	0.80	810	7.8	4323	2.6	3.0	20.50	3150	76
500 ⁴⁾	M3BP 400 LC	3GBP 403 530...G	994	96.6	96.6	96.1	0.82	878	7.6	4803	2.7	2.9	22.00	3300	76
500 ⁴⁾	M3BP 400 LKC	3GBP 403 830...G	994	96.6	96.6	96.1	0.82	878	7.6	4803	2.7	2.9	22.00	3300	76
560 ⁴⁾	M3BP 400 LD	3GBP 403 540...G	994	96.9	96.8	96.2	0.83	968	7.8	5379	2.6	3.0	24.00	3400	77
560 ⁴⁾	M3BP 400 LKD	3GBP 403 840...G	994	96.9	96.8	96.2	0.83	968	7.8	5379	2.6	3.0	24.00	3400	77
630 ⁴⁾	M3BP 450 LA	3GBP 453 510...G	995	96.8	96.8	96.3	0.83	1090	7.0	6046	1.2	2.7	31.00	4150	81
710 ⁴⁾	M3BP 450 LB	3GBP 453 520...G	995	96.9	96.9	96.4	0.84	1213	7.5	6814	1.4	2.7	37.00	4500	81
800 ¹⁴⁾	M3BP 450 LC	3GBP 453 530...G	995	96.9	96.9	96.5	0.83	1383	7.7	7677	1.4	2.9	41.00	4800	81

¹⁾ Temperature rise class F

⁴⁾ Output powers below 0.75 kW and above 185 kW are not subject to Australian MEPS requirement
Efficiency values are given according to IEC 60034-2 - 1; 2007

Technical data

IE2 cast iron motors according to AU MEPS, 1000 r/min

IP 55 - IC 411 - Insulation class F, temperature rise class B. IE2 efficiency class according to IEC 60034-30; 2008.

Output kW	Motor type	Product code	Speed r/min	Efficiency IEC 60034-2-1; 2007			Power factor cos φ	Current		Torque			Moment of inertia J = 1/4 GD ² kgm ²	Weight kg	Sound pressure level L _{PA} dB
				Full load 100%	3/4 load 75%	1/2 load 50%		I _N A	I _s / I _N	T _N Nm	T _i / T _N	T _p / T _N			
1000 r/min = 6 poles				415 V 50 Hz				High-output design							
15	M3BP 160 MLC	3GBP 163 033-...G	976	89.6	90.3	90.0	0.75	31.0	7.7	146	2.0	3.9	0.13	185	59
18.5	M3BP 180 MLB	3GBP 183 034-...G	978	90.8	91.5	91.2	0.77	36.8	6.2	180	1.9	2.9	0.20	221	59
30 ¹⁾	M3BP 200 MLC	3GBP 203 033-...G	987	92.0	92.6	92.2	0.79	57.4	7.2	290	2.5	3.1	0.53	318	63
37	M3BP 225 SMB	3GBP 223 034-...G	987	92.8	93.5	93.6	0.83	66.8	7.1	357	2.5	2.9	0.82	393	63
45 ¹⁾	M3BP 225 SMC	3GBP 223 033-...G	985	92.6	93.3	93.3	0.82	82.4	6.9	436	2.5	2.8	0.82	393	63
45	M3BP 250 SMB	3GBP 253 032-...G	991	93.2	93.6	93.4	0.80	83.9	7.5	433	2.7	2.9	1.37	441	63
55 ¹⁾	M3BP 250 SMC	3GBP 253 033-...G	990	93.4	94.0	93.8	0.81	101	7.6	530	2.8	3.0	1.50	468	63
75	M3BP 280 SMC	3GBP 283 230-...G	990	95.6	95.8	95.3	0.83	133	7.8	723	3.1	2.9	2.85	725	66
90	M3BP 280 MLA	3GBP 283 410-...G	990	94.0	94.1	93.3	0.79	170	7.5	868	2.6	2.7	3.10	840	70
110	M3BP 280 MLB	3GBP 283 420-...G	990	94.4	94.5	93.7	0.80	204	8.0	1061	3.0	2.8	4.10	890	70
150	M3BP 315 LKA	3GBP 313 810-...G	991	95.3	95.3	94.5	0.79	269	8.4	1445	3.0	3.2	7.30	1410	74
185	M3BP 315 LKB	3GBP 313 820-...G	991	95.6	95.6	95.1	0.82	330	7.7	1782	2.7	2.9	8.30	1520	74
185	M3BP 315 LKC	3GBP 313 830-...G	991	95.9	96.0	95.5	0.82	326	7.7	1782	2.9	3.0	9.20	1600	74
200 ⁴⁾	M3BP 315 LKC	3GBP 313 830-...G	990	95.5	95.6	95.2	0.84	351	7.3	1929	2.7	2.8	9.20	1600	74

¹⁾ Temperature rise class F

⁴⁾ Output powers below 0.75kW and above 185kW are not subject to Australian MEPS requirement
Efficiency values are given according to IEC 60034-2 - 1; 2007

Technical data

IE2 cast iron motors according to AU MEPS, 750 r/min

IP 55 - IC 411 - Insulation class F, temperature rise class B. IE2 efficiency class according to IEC 60034-30; 2008.

Output kW	Motor type	Product code	Speed r/min	Efficiency IEC 60034-2-1; 2007			Power factor cos φ	Current		Torque			Moment of inertia J = 1/4 GD ² kgm ²	Weight kg	Sound pressure level L _{PA} dB
				Full load 100%	3/4 load 75%	1/2 load 50%		I _N A	I _s /I _N	T _N Nm	T ₁ /T _N	T _b /T _N			
750 r/min = 8 poles				415 V 50 Hz				CENELEC-design							
0.09 ⁴⁾	M3BP 71 MA	3GBP 074 101...B	670	48.6	44.5	36.8	0.57	0.45	2.1	1.28	1.9	2.1	0.00089	11	40
0.12 ⁴⁾	M3BP 71 MB	3GBP 074 102...B	680	50.2	45.8	37.9	0.53	0.62	2.2	1.68	3.0	2.6	0.0011	12	43
0.18 ⁴⁾	M3BP 80 MA	3GBP 084 101...B	705	56.5	53.0	45.7	0.60	0.73	3.6	2.4	2.4	2.7	0.0019	15	45
0.25 ⁴⁾	M3BP 80 MB	3GBP 084 102...B	690	61.4	60.1	54.1	0.62	0.91	3.1	3.4	2.2	2.1	0.0024	17	50
0.37 ⁴⁾	M3BP 90 SLB	3GBP 094 102...B	710	65.1	62.3	54.5	0.52	1.52	2.8	4.9	1.5	2.3	0.0044	24	50
0.55 ⁴⁾	M3BP 90 SLC	3GBP 094 103...B	665	62.9	65.2	63.6	0.64	1.9	2.4	7.8	1.2	1.6	0.0049	25	53
0.75	M3BP 100 LB	3GBP 104 442...B	725	74.1	71.1	65.0	0.51	2.7	4.2	9.8	2.8	3.7	0.0087	34	53
1.1	M3BP 100 LC	3GBP 104 443...B	705	74.9	73.8	69.4	0.63	3.2	3.6	14.8	1.9	2.4	0.0095	35	46
1.5	M3BP 112 MB	3GBP 114 442...B	710	77.0	75.6	71.0	0.61	4.4	4.1	20.1	2.6	2.9	0.013	42	52
2.2	M3BP 132 SMB	3GBP 134 443...B	730	79.5	77.6	72.6	0.55	7.0	5.4	28.7	2.1	4.2	0.040	75	56
3	M3BP 132 SME	3GBP 134 444...B	720	81.3	79.1	76.8	0.63	8.1	5.9	39.7	1.8	3.5	0.048	86	58
4	M3BP 160 MLA	3GBP 164 031...G	733	84.2	84.4	82.6	0.63	10.4	5.6	52.1	1.7	2.9	0.068	120	59
5.5	M3BP 160 MLB	3GBP 164 032...G	731	84.5	84.9	83.6	0.63	14.3	5.7	71.8	1.5	2.9	0.085	134	59
7.5	M3BP 160 MLC	3GBP 164 033...G	732	85.8	86.4	85.3	0.63	19.3	4.9	97.8	1.6	3.1	0.132	184	59
11	M3BP 180 MLA	3GBP 184 031...G	735	86.0	86.8	85.8	0.65	27.3	4.6	142	2.0	2.8	0.214	233	59
15	M3BP 200 MLA	3GBP 204 031...G	739	89.4	90.0	89.1	0.72	32.4	5.5	193	2.2	2.6	0.450	290	60
18.5	M3BP 225 SMA	3GBP 224 031...G	739	90.0	90.5	90.3	0.72	39.7	5.6	239	2.2	2.5	0.669	350	63
22	M3BP 225 SMB	3GBP 224 032...G	739	90.8	91.4	90.7	0.71	47.4	5.8	284	2.2	2.5	0.722	363	63
30	M3BP 250 SMA	3GBP 254 031...G	743	91.8	92.1	91.2	0.68	66.8	6.1	385	2.8	2.6	1.404	440	63
37	M3BP 280 SMA	3GBP 284 210...G	742	93.0	93.0	91.9	0.77	71.8	7.7	476	1.8	3.2	1.850	605	65
45	M3BP 280 SMB	3GBP 284 220...G	741	93.3	93.3	92.2	0.76	88.2	8.0	579	2.0	3.3	2.200	645	65
55	M3BP 315 SMA	3GBP 314 210...G	742	93.4	93.4	92.5	0.78	105	7.5	707	1.7	2.9	3.200	830	62
75	M3BP 315 SMB	3GBP 314 220...G	740	93.7	93.8	93.2	0.77	144	7.6	967	1.8	2.9	4.100	930	62
75	M3BP 315 SMB	3GBP 314 220...G	741	93.7	94.1	93.6	0.82	135	7.1	966	1.7	2.7	4.100	930	62
90	M3BP 315 SMC	3GBP 314 230...G	739	94.2	94.3	93.7	0.80	166	8.0	1162	2.0	2.9	4.900	1000	64
110	M3BP 355 SMA	3GBP 354 210...G	745	95.6	95.2	93.9	0.72	222	9.2	1409	2.0	3.4	7.900	1520	69
132	M3BP 355 SMA	3GBP 354 210...G	744	95.4	95.3	94.5	0.75	256	8.0	1694	1.7	2.8	7.900	1520	69
150	M3BP 355 SMB	3GBP 354 220...G	744	95.5	95.4	94.6	0.75	291	8.3	1925	1.9	3.1	9.700	1680	69
160	M3BP 355 SMB	3GBP 354 220...G	744	95.4	95.4	94.6	0.77	303	8.1	2053	1.8	2.8	9.700	1680	69
185	M3BP 355 SMC	3GBP 354 230...G	743	95.5	95.4	94.6	0.76	354	8.3	2377	1.9	3.0	11.300	1820	69
200 ⁴⁾	M3BP 355 SMC	3GBP354230...G	744	95.3	95.3	94.5	0.78	374	7.9	2567	1.8	2.8	11.300	1820	69
250 ⁴⁾	M3BP 355 MLB	3GBP 354 420...G	743	95.4	95.4	94.8	0.78	467	8.0	3213	1.8	2.9	13.500	2180	72
315 ¹⁾⁴⁾	M3BP 355 LKB	3GBP 354 820...G	743	95.5	95.5	94.9	0.78	588	8.4	4048	1.9	2.9	16.500	2600	75
315 ⁴⁾	M3BP 400 LA	3GBP 404 510...G	744	96.1	96.2	95.6	0.79	577	7.3	4043	1.3	2.8	17.000	2900	71
315 ⁴⁾	M3BP 400 LKA	3GBP 404 810...G	744	96.1	96.2	95.6	0.79	577	7.3	4043	1.3	2.8	17.000	2900	71
355 ⁴⁾	M3BP 400 LB	3GBP 404 520...G	744	96.2	96.3	95.9	0.82	626	7.4	4556	1.3	2.7	21.000	3200	71
355 ⁴⁾	M3BP 400 LKB	3GBP 404 820...G	744	96.2	96.3	95.9	0.82	626	7.4	4556	1.3	2.7	21.000	3200	71
400 ⁴⁾	M3BP 400 LC	3GBP 404 530...G	744	96.3	96.3	95.9	0.80	722	7.9	5134	1.4	2.9	24.000	3400	71
400 ⁴⁾	M3BP 400 LKC	3GBP 404 830...G	744	96.3	96.3	95.9	0.80	722	7.9	5134	1.4	2.9	24.000	3400	71
450 ⁴⁾	M3BP 450 LA	3GBP 454 510...G	744	96.3	96.3	96.1	0.81	802	6.4	5775	1.1	2.7	26.000	3750	80
500 ⁴⁾	M3BP 450 LB	3GBP 454 520...G	744	96.3	96.4	96.1	0.81	891	6.8	6417	1.1	2.8	29.000	4000	80
560 ⁴⁾	M3BP 450 LC	3GBP 454 530...G	745	96.4	96.4	96.0	0.80	1010	7.4	7177	1.3	3.2	35.000	4350	80
630 ¹⁾⁴⁾	M3BP 450 LD	3GBP 454 540...G	745	96.6	96.6	96.1	0.79	1148	8.0	8075	1.4	3.5	41.000	4800	80
750 r/min = 8 poles				415 V 50 Hz				High-output design							
55	M3BP 280 SMC	3GBP 284 230...G	740	93.5	93.6	92.7	0.77	106	8.4	709	2.1	3.3	2.850	725	65

¹⁾ Temperature rise class F

⁴⁾ Output powers below 0.75 kW and above 185 kW are not subject to Australian MEPS requirement
Efficiency values are given according to IEC 60034-2 - 1; 2007

Technical data

Cast iron motors according to AU MEPS, 600 and 500 r/min

IP 55 - IC 411 - Insulation class F, temperature rise class B.

Output kW	Motor type	Product code	Speed r/min	Efficiency IEC 60034-2-1; 2007			Power factor cos φ	Current		Torque			Moment of inertia J = 1/4 GD ² kgm ²	Weight kg	Sound pressure level L _{PA} dB
				Full load 100%	3/4 load 75%	1/2 load 50%		I _N A	I _s /I _N	T _N Nm	T _i /T _N	T _p /T _N			
600 r/min = 10 poles				415 V 50 Hz				GENELEC-design							
37	M3BP 280 SMB	3GBP 285 220-...G	593	92.5	92.1	90.5	0.70	79.4	6.9	595	1.7	3.2	2.20	645	60
45	M3BP 280 SMC	3GBP 285 230-...G	593	92.9	92.7	91.2	0.72	93.5	6.9	725	1.8	3.0	2.85	725	60
55	M3BP 315 SMB	3GBP 315 220-...G	595	93.8	93.7	92.6	0.76	107	6.9	884	1.7	2.9	4.10	930	70
75	M3BP 315 SMC	3GBP 315 230-...G	594	93.6	93.5	92.4	0.76	146	7.0	1207	1.6	3.0	4.90	1000	70
90	M3BP 315 MLA	3GBP 315 410-...G	594	93.7	93.7	92.7	0.75	178	6.8	1449	1.8	2.9	5.80	1150	70
110	M3BP 355 SMA	3GBP 355 210-...G	595	94.5	94.4	93.3	0.74	218	7.0	1765	1.4	2.7	7.90	1520	73
132	M3BP 355 SMB	3GBP 355 220-...G	595	94.8	94.8	94.0	0.77	251	6.8	2122	1.4	2.6	9.70	1680	73
160	M3BP 355 SMC	3GBP 355 230-...G	595	94.8	94.8	93.8	0.75	313	7.0	2572	1.5	2.7	11.30	1820	76
200	M3BP 355 MLB	3GBP 355 420-...G	594	95.0	95.0	94.3	0.76	385	6.8	3215	1.5	2.6	13.500	2180	77
250 ¹⁾	M3BP 355 LKB	3GBP 355 820-...G	594	95.2	95.3	94.6	0.76	480	6.6	4025	1.5	2.5	16.500	2600	79
250	M3BP 400 LB	3GBP 405 520-...G	595	95.3	95.2	94.3	0.72	506	6.6	4012	1.4	2.4	20.000	3100	79
250	M3BP 400 LKB	3GBP 405 820-...G	595	95.3	95.2	94.3	0.72	506	6.6	4012	1.4	2.4	20.000	3100	79
315	M3BP 400 LC	3GBP 405 530-...G	595	95.4	95.3	94.5	0.72	638	6.6	5055	1.4	2.4	24.000	3400	79
315	M3BP 400 LKC	3GBP 405 830-...G	595	95.4	95.3	94.5	0.72	638	6.6	5055	1.4	2.4	24.000	3400	79
355	M3BP 450 LA	3GBP 455 510-...G	596	96.0	95.8	94.9	0.69	745	6.0	5687	1.2	2.4	31.000	4050	82
400	M3BP 450 LB	3GBP 455 520-...G	596	95.9	95.8	94.8	0.69	840	5.9	6408	1.1	2.2	34.000	4250	82
450	M3BP 450 LC	3GBP 455 530-...G	596	96.1	96.0	95.2	0.70	930	6.0	7210	1.1	2.2	38.000	4550	82
500 ¹⁾	M3BP 450 LD	3GBP 455 540-...G	596	96.1	96.0	95.1	0.68	1064	6.3	8011	1.2	2.3	42.000	4800	82
500 r/min = 12 poles				415 V 50 Hz				CENELEC-design							
30	M3BP 280 SMB	3GBP 286 220-...G	493	90.0	89.0	86.1	0.55	84.3	5.9	581	2.1	3.2	2.20	645	71
37	M3BP 280 SMC	3GBP 286 230-...G	494	90.4	89.4	86.4	0.55	103	6.5	716	2.2	3.4	2.85	725	71
45	M3BP 315 SMB	3GBP 316 220-...G	494	92.9	92.8	91.7	0.74	91	6.8	869	1.7	2.8	4.10	930	71
55	M3BP 315 SMC	3GBP 316 230-...G	494	93.1	93.0	92.0	0.74	111	6.8	1065	1.7	2.8	4.90	1000	71
75	M3BP 315 MLA	3GBP 316 410-...G	494	93.2	93.3	92.5	0.74	151	6.6	1452	1.7	2.7	5.80	1150	71
90	M3BP 355 SMA	3GBP 356 210-...G	495	93.5	93.4	92.1	0.69	194	5.9	1736	1.4	2.5	7.90	1520	75
110	M3BP 355 SMB	3GBP 356 220-...G	495	93.8	93.6	92.3	0.68	239	6.2	2122	1.5	2.7	9.70	1680	75
132	M3BP 355 SMC	3GBP 356 230-...G	495	93.8	93.7	92.5	0.68	287	6.3	2546	1.5	2.7	11.30	1820	77
160	M3BP 355 MLB	3GBP 356 420-...G	495	93.8	93.9	93.0	0.71	334	5.9	3092	1.4	2.5	13.50	2180	77
200 ¹⁾	M3BP 355 LKB	3GBP 356 820-...G	495	93.9	93.9	93.0	0.70	423	6.1	3866	1.5	2.6	16.50	2600	79
200	M3BP 400 LB	3GBP 406 520-...G	495	95.1	95.0	94.1	0.77	379	5.7	3858	1.2	2.3	20.0	3100	82
200	M3BP 400 LKB	3GBP 406 820-...G	495	95.1	95.0	94.1	0.77	379	5.7	3858	1.2	2.3	20.0	3100	82
250	M3BP 400 LC	3GBP 406 530-...G	495	95.2	95.2	94.3	0.77	474	6.0	4822	1.2	2.3	24.0	3400	82
250	M3BP 400 LKC	3GBP 406 830-...G	495	95.2	95.2	94.3	0.77	474	6.0	4822	1.2	2.3	24.0	3400	82
315	M3BP 450 LB	3GBP 456 520-...G	496	95.1	95.2	94.4	0.72	620	5.7	6064	1.1	2.1	34.0	4300	82
355	M3BP 450 LC	3GBP 456 530-...G	496	95.7	95.6	94.8	0.74	697	5.6	6848	1.1	2.1	38.0	4550	82
400 ¹⁾	M3BP 450 LD	3GBP 456 540-...G	496	95.7	95.7	95.0	0.75	775	5.6	7716	1.1	2.2	42.0	4800	82

¹⁾ Temperature rise class F
Efficiency values are given according to IEC 60034-2 - 1; 2007

Technical data

IE3 cast iron motors according to AU MEPS, 3000 r/min

IP 55 - IC 411 - Insulation class F, temperature rise class B
IE3 efficiency class according to IEC 60034-30; 2008

Output kW	Motor type	Product code	Speed r/min	Efficiency IEC 60034-2-1; 2007			Power factor cos φ	Current		Torque			Moment of inertia J = 1/4 GD ² kgm ²	Weight kg	Sound pressure level L _{PA} dB
				Full load 100%	3/4 load 75%	1/2 load 50%		I _N A	I _s / I _N	T _N Nm	T ₁ / T _N	T _b / T _N			
3000 r/min = 2 poles				415 V 50 Hz				CENELEC-design							
11	M3BP 160 MLA	3GBP 161 051-...K	2954	92.2	92.8	92.2	0.89	18.6	8.7	35.5	2.9	3.6	0.052	141	69
15	M3BP 160 MLB	3GBP 161 052-...K	2956	93.1	93.5	93.0	0.89	25.1	9.0	48.4	3.3	3.7	0.062	170	69
18.5	M3BP 160 MLC	3GBP 161 053-...K	2953	92.9	93.5	93.3	0.90	30.7	8.9	59.8	3.3	3.9	0.072	183	69
22	M3BP 180 MLA	3GBP 181 051-...K	2961	93.8	94.4	94.3	0.91	35.8	8.7	70.9	2.8	3.5	0.116	234	69
30	M3BP 200 MLA	3GBP 201 051-...K	2964	94.3	94.7	94.7	0.89	49.7	8.4	96.6	3.0	3.4	0.196	298	72
37	M3BP 200 MLB	3GBP 201 052-...K	2968	94.8	95.2	95.1	0.88	61.7	9.4	119	3.4	3.7	0.217	314	72
45	M3BP 225 SMA	3GBP 221 051-...K	2974	95.5	95.6	95.2	0.90	72.8	8.4	144	3.3	3.2	0.323	409	74
55	M3BP 250 SMA	3GBP 251 051-...K	2978	95.7	95.9	95.5	0.88	90.8	8.6	176	3.0	3.5	0.579	452	75
75	M3BP 280 SMB	3GBP 281 220-...K	2980	96.4	96.2	95.2	0.87	126.5	8.3	240	2.3	3.1	0.900	665	77
90	M3BP 280 SMC	3GBP 281 230-...K	2982	96.5	96.3	95.4	0.87	149.2	8.7	288	2.7	3.3	1.150	725	77
110	M3BP 315 SMB	3GBP 311 220-...K	2984	96.5	96.3	95.4	0.86	183.8	7.7	352	2.1	2.8	1.400	940	77
132	M3BP 315 SMC	3GBP 311 230-...K	2986	96.9	95.8	96.0	0.87	220.1	8.6	422	2.6	3.2	1.700	1025	77
150	M3BP 315 MLA	3GBP 311 410-...K	2985	97.2	97.1	96.5	0.88	243.8	8.3	479	2.6	3.1	2.100	1190	77
160	M3BP 315 MLB	3GBP 311 420-...K	2983	97.2	97.1	96.5	0.89	257.0	7.6	512	2.4	2.9	2.100	1190	77
185	M3BP 315 MLB	3GBP 311 420-...K	2985	97.3	97.2	96.7	0.88	299.4	8.4	591	2.6	3.1	2.200	1220	77
185 ¹⁾	M3BP 355 SMA	3GBP 351 210-...K	2986	97.0	96.7	95.8	0.87	303.9	8.7	591	2.3	3.6	3.000	1600	83
200 ²⁾	M3BP 315 MLA	3GBP 311 410-...L	2984	95.8	95.8	95.2	0.87	334	8.2	640	2.7	3.3	2.100	1190	81
200 ²⁾	M3BP 315 MLB	3GBP 311 420-...K	2983	96.2	96.2	96.0	0.89	324	7.8	640	2.4	2.9	2.200	1220	77
200 ²⁾	M3BP 355 SMA	3GBP 351 210-...K	2985	96.2	96.1	95.4	0.89	324	8.2	639	2.1	3.3	3.000	1600	83
250 ²⁾	M3BP 315 LKB	3GBP 311 820-...K	2983	96.3	96.3	96.1	0.91	396	8.5	800	2.7	2.9	2.900	1540	77
250 ²⁾	M3BP 315 LKB	3GBP 311 820-...L	2984	95.8	95.9	95.5	0.89	408	8.2	800	2.7	3.6	2.900	1540	81
250 ¹⁾²⁾	M3BP 355 SMA	3GBP 351 210-...L	2985	96.0	95.7	94.6	0.88	412	8.2	800	2.3	3.5	3.000	1600	83
250 ¹⁾²⁾	M3BP 355 SMB	3GBP 351 220-...K	2984	96.3	96.3	95.8	0.89	405	8.1	800	2.4	3.2	3.400	1680	83
315 ¹⁾²⁾	M3BP 355 SMB	3GBP 351 220-...L	2982	96.1	96.0	95.2	0.88	518	7.6	1009	2.3	3.2	3.400	1680	83
315 ¹⁾²⁾	M3BP 355 SMC	3GBP 351 230-...K	2985	96.4	96.4	95.8	0.88	516	8.4	1007	2.5	3.0	3.600	1750	83
355 ¹⁾²⁾	M3BP 355 SMC	3GBP 351 230-...L	2985	96.2	96.1	95.4	0.88	583	7.9	1136	2.4	3.2	3.600	1750	83
355 ¹⁾²⁾	M3BP 355 MLA	3GBP 351 410-...K	2984	96.5	96.5	96.2	0.89	575	7.9	1136	2.5	2.8	4.100	2000	83

¹⁾ -3dB(A) sound pressure level reduction with unidirectional fan construction. Direction of rotation must be stated when ordering, see variant codes 044 and 045

²⁾ Output powers below 0.75 kW and above 185 kW are not subject to Australian MEPS requirement

Efficiency values are given according to IEC 60034-2 - 1; 2007

Technical data

IE3 cast iron motors according to AU MEPS, 1500 r/min

IP 55 - IC 411 - Insulation class F, temperature rise class B
IE3 efficiency class according to IEC 60034-30; 2008

Output kW	Motor type	Product code	Speed r/min	Efficiency IEC 60034-2-1; 2007			Power factor cos φ	Current		Torque			Moment of inertia J = 1/4 GD ² kgm ²	Weight kg	Sound pressure level L _{PA} dB
				Full load 100%	3/4 load 75%	1/2 load 50%		I _N A	I _s / I _N	T _N Nm	T _i / T _N	T _b / T _N			
1500 r/min = 4 poles				415 V 50 Hz				CENELEC-design							
11	M3BP 160 MLA	3GBP 162 051-...K	1477	92.3	92.9	92.6	0.82	20.2	8.3	71.1	2.8	3.2	0.108	173	62
15	M3BP 160 MLB	3GBP 162 052-...K	1477	92.7	93.2	93.1	0.82	27.4	8.4	96.9	3.0	3.5	0.125	187	62
18.5	M3BP 180 MLA	3GBP 182 051-...K	1484	93.6	94.0	93.6	0.81	33.9	8.2	119	3.3	3.3	0.217	235	62
22	M3BP 180 MLB	3GBP 182 052-...K	1483	93.2	93.6	93.4	0.80	41.0	8.6	141	3.0	3.3	0.217	235	62
30	M3BP 200 MLA	3GBP 202 051-...K	1484	94.7	95.1	94.9	0.80	55.0	8.8	193	3.3	3.6	0.366	319	63
37	M3BP 225 SMA	3GBP 222 051-...K	1484	95.1	95.5	95.4	0.84	64.4	8.3	238	3.0	3.3	0.536	398	66
45	M3BP 225 SMB	3GBP 222 052-...K	1482	95.2	95.6	95.6	0.84	78.2	8.5	289	3.1	3.4	0.536	398	66
55	M3BP 250 SMA	3GBP 252 051-...K	1486	95.6	95.8	95.5	0.83	96.4	8.5	353	3.2	3.6	0.933	476	67
75	M3BP 280 SMB	3GBP 282 220-...K	1487	96.2	96.2	95.6	0.83	131.5	7.8	481	2.7	3.0	1.500	665	72
90	M3BP 280 SMC	3GBP 282 230-...K	1487	96.3	96.3	95.7	0.83	157.7	8.4	577	3.1	3.2	1.850	725	72
110	M3BP 315 SMC	3GBP 312 230-...K	1491	96.8	96.7	96.1	0.83	190.4	8.8	704	2.6	3.3	2.900	1000	68
132	M3BP 315 SMD	3GBP 312 240-...K	1490	96.9	96.8	96.2	0.82	229.2	8.6	845	2.8	3.4	3.200	1065	68
150	M3BP 315 MLB	3GBP 312 420-...K	1490	96.8	96.8	96.2	0.85	257.7	9.0	961	3.1	3.4	3.900	1220	68
160	M3BP 315 MLB	3GBP 312 420-...K	1489	96.7	96.7	96.3	0.85	271.0	8.8	1026	2.9	3.2	3.900	1220	68
185	M3BP 315 LKB	3GBP 312 820-...K	1491	97.0	97.0	96.4	0.85	314.5	8.7	1184	2.9	3.4	5.000	1520	74
185	M3BP 355 SMA	3GBP 352 210-...K	1492	97.1	97.1	96.5	0.85	319.8	8.1	1184	2.5	3.1	5.900	1610	74
200 ²⁾	M3BP 315 MLB	3GBP 312 420-...L	1488	96.0	96.3	96.0	0.85	341	7.3	1284	2.6	3.2	3.900	1220	74
200 ²⁾	M3BP 315 LKB	3GBP 312 820-...K	1491	96.5	96.5	96.1	0.86	335	8.2	1280	2.7	3.1	5.000	1520	74
200 ²⁾	M3BP 355 SMA	3GBP 352 210-...K	1491	96.5	96.5	96.2	0.86	335	7.7	1280	2.3	2.9	5.900	1610	74
250 ²⁾	M3BP 315 LKA	3GBP 312 810-...L	1489	96.0	96.2	95.9	0.84	431	7.4	1604	2.7	3.4	4.400	1410	78
250 ²⁾	M3BP 315 LKC	3GBP 312 830-...K	1491	96.6	96.6	96.4	0.85	423	8.2	1601	2.5	3.2	5.500	1600	74
250 ²⁾	M3BP 355 SMA	3GBP 352 210-...L	1491	96.2	96.2	95.6	0.85	425	6.9	1601	2.3	3.1	5.900	1610	78
250 ²⁾	M3BP 355 SMB	3GBP 352 220-...K	1492	96.6	96.6	96.2	0.86	418	8.4	1600	2.7	3.1	6.900	1780	74
315 ²⁾	M3BP 355 SMB	3GBP 352 220-...L	1492	96.2	96.2	95.6	0.85	536	7.8	2017	2.5	3.5	6.900	1780	78
315 ²⁾	M3BP 355 SMC	3GBP 352 230-...K	1492	96.7	96.7	96.2	0.84	539	7.9	2016	3.0	3.1	7.200	1820	74
355 ²⁾	M3BP 355 SMC	3GBP 352 230-...L	1491	96.0	96.1	95.5	0.85	605	6.8	2273	2.5	3.0	7.200	1820	78
355 ²⁾	M3BP 355 MLA	3GBP 352 410-...K	1492	96.7	96.7	96.3	0.85	600	8.5	2272	2.9	3.1	8.400	2140	78

²⁾ Output powers below 0.75 kW and above 185 kW are not subject to Australian MEPS requirement
Efficiency values are given according to IEC 60034-2 - 1; 2007

Technical data

IE3 cast iron motors according to AU MEPS, 1000 r/min

IP 55 - IC 411 - Insulation class F, temperature rise class B

IE3 efficiency class according to IEC 60034-30; 2008

Output kW	Motor type	Product code	Speed r/min	Efficiency IEC 60034-2-1; 2007			Power factor cos φ	Current					Moment of inertia J = 1/4 GD ² kgm ²	Weight kg	Sound pressure level L _{PA} dB
				Full load 100%	3/4 load 75%	1/2 load 50%		I _N A	I _s /I _N	T _N Nm	T _I /T _N	T _b /T _N			
1000 r/min = 6 poles				415 V 50 Hz				CENELEC-design							
7.5	M3BP 160 MLA	3GBP 163 051-...K	981	90.0	91.3	90.8	0.76	15.2	8.4	73.0	1.9	3.6	0.114	172	59
11	M3BP 160 MLB	3GBP 163 052-...K	983	90.7	90.9	90.0	0.72	23.4	8.8	106	2.4	4.2	0.131	185	59
15	M3BP 180 MLA	3GBP 183 051-...K	982	91.8	92.5	92.5	0.77	29.5	8.3	145	2.4	3.8	0.225	234	59
18.5	M3BP 200 MLA	3GBP 203 051-...K	991	92.4	92.5	91.8	0.75	37.1	7.8	178	2.8	3.5	0.448	291	63
22	M3BP 200 MLB	3GBP 203 052-...K	990	93.0	93.1	92.3	0.78	42.1	8.1	212	2.8	3.5	0.531	318	63
30	M3BP 225 SMA	3GBP 223 051-...K	990	94.2	94.5	94.2	0.78	56.8	8.4	289	3.1	3.4	0.813	392	63
37	M3BP 250 SMA	3GBP 253 051-...K	992	94.5	94.9	94.6	0.79	68.9	8.2	356	3.0	3.1	1.486	467	63
45	M3BP 280 SMB	3GBP 283 220-...K	992	95.5	95.7	95.1	0.83	78.9	8.3	433	3.4	2.8	2.200	680	65
55	M3BP 280 SMC	3GBP 283 230-...K	990	95.4	95.6	95.1	0.83	97.0	7.9	530	3.0	2.8	2.850	725	65
75	M3BP 315 SMC	3GBP 313 230-...K	994	96.4	96.4	95.7	0.80	135.0	7.6	720	2.5	3.0	4.900	1000	67
90	M3BP 315 SMD	3GBP 313 240-...K	994	96.0	96.0	95.3	0.78	168.0	8.0	864	2.9	3.4	4.900	1040	67
110	M3BP 315 MLB	3GBP 313 420-...K	994	96.5	96.6	96.0	0.81	198.0	7.3	1056	2.6	2.9	6.300	1200	68
132	M3BP 315 LKA	3GBP 313 810-...K	993	96.6	96.7	96.2	0.80	237.5	7.6	1269	2.7	2.9	7.300	1410	68
150	M3BP 315 LKC	3GBP 313 830-...K	994	96.8	96.8	96.1	0.78	278.0	7.8	1441	2.9	3.1	9.200	1600	68
150	M3BP 355 SMB	3GBP 353 220-...K	995	96.7	96.6	96.0	0.79	273.0	7.7	1439	2.4	3.1	9.700	1680	73
160	M3BP 315 LKC	3GBP 313 830-...K	994	96.7	96.6	96.0	0.80	288.0	7.5	1537	3.0	3.1	9.200	1600	68
185	M3BP 355 SMC	3GBP 353 230-...K	996	96.5	96.4	95.7	0.79	340.0	8.1	1773	2.7	3.2	11.300	1820	73
200 ²⁾	M3BP 355 SMB	3GBP 353 220-...L	993	95.9	96.0	95.7	0.81	358	7.2	1923	2.8	2.7	9.700	1680	75
200 ²⁾	M3BP 355 SMC	3GBP 353 230-...K	995	96.0	96.0	95.5	0.81	357	7.7	1919	2.5	3.0	11.300	1820	73
250 ²⁾	M3BP 355 SMC	3GBP 353 230-...L	994	95.9	96.0	95.6	0.79	459	8.2	2404	3.2	3.3	11.300	1820	75
250 ²⁾	M3BP 355 MLB	3GBP 353 420-...K	995	96.0	96.0	95.6	0.82	441	7.6	2399	2.5	2.9	13.500	2180	73
315 ²⁾	M3BP 355 MLB	3GBP 353 420-...L	993	96.0	96.2	95.9	0.81	564	7.3	3029	2.8	3.4	13.500	2180	76
315 ²⁾	M3BP 355 LKA	3GBP 353 810-...K	995	96.0	96.0	95.7	0.82	556	7.4	3023	2.5	2.8	15.500	2500	76
355 ²⁾	M3BP 355 LKA	3GBP 353 810-...L	993	96.0	96.1	95.7	0.79	651	8	3413	3.1	3.4	15.500	2500	76
355 ²⁾	M3BP 355 LKB	3GBP 353 820-...K	995	96.0	96.0	95.4	0.78	659	8.1	3407	2.9	3.1	16.500	2600	76

²⁾ Output powers below 0.75 kW and above 185 kW are not subject to Australian MEPS requirement
Efficiency values are given according to IEC 60034-2 - 1; 2007

Variant codes

Cast iron motors

Variant codes specify additional options and features to the standard motor. The desired features are listed as three-digit variant codes in the motor order. Note also that there are variants that cannot be used together.

Most of the variant codes apply to IE2, IE3, and IE4 motors. However, confirm the availability of variants for IE3 and IE4 motors with your ABB sales office before making an order.

Code/ Variant, M3BP	Frame size																
	71	80	90	100	112	132	160	180	200	225	250	280	315	355	400	450	
Administration																	
530	Two-year extension on standard warranty	NA	NA	NA	NA	NA	NA	R	R	R	R	R	P	P	P	P	P
531	Sea freight packing	NA	P	P	P	P	P	NA	NA	NA	NA	NA	P	P	P	P	P
532	Packing of motor in vertical mounting position	NA	NA	NA	NA	NA	NA	NA	NA	NA	NA	NA	P	P	NA	NA	NA
533	Wooden sea freight packing	P	P	P	P	P	P	NA	NA	NA	NA	NA	P	P	P	P	P
Balancing																	
417	Vibration acc. to Grade B (IEC 60034-14).	P	P	P	P	P	P	P	P	P	P	P	P	P	P	P	R
423	Balanced without key.	P	P	P	P	P	P	P	P	P	P	P	P	P	P	P	P
424	Full-key balancing	P	P	P	P	P	P	P	P	P	P	P	P	P	P	P	P
Bearings and Lubrication																	
036	Transport lock for bearings.	M	M	M	M	M	M	M	M	M	M	M	P	P	P	P	P
037	Roller bearing at D-end.	P	P	P	P	P	P	M	M	M	M	M	P	P	P	P	P
039	Cold-resistant grease	M	M	M	M	M	M	NA	NA	NA	NA	NA	P	P	P	P	P
040	Heat-resistant grease	M	M	M	M	M	M	S	S	S	S	S	P	P	P	P	P
041	Bearings regreasable via grease nipples.	M	M	M	M	M	M	S	S	S	S	S	S	S	S	S	S
042	Locked D-end	S	S	S	S	S	S	S	S	S	S	S	S	S	S	S	S
043	SPM compatible nipples for vibration measurement	M	M	M	M	M	M	S	S	S	S	S	S	S	S	S	S
057	2RS bearings at both ends.	M	M	M	M	M	M	M	M	M	M	M	NA	NA	NA	NA	NA
058	Angular contact bearing at D-end, shaft force away from bearing.	M	M	M	M	M	M	M	M	M	M	M	P	P	P	P	P
059	Angular contact bearing at N-end, shaft force towards bearing.	M	M	M	M	M	M	P	P	P	P	P	P	P	P	P	P
060	Angular contact bearing at D-end, shaft force towards bearing.	NA	NA	NA	NA	NA	NA	NA	NA	NA	NA	NA	P	P	P	P	P
061	Angular contact bearing at N-end, shaft force away from bearing.	NA	NA	NA	NA	NA	NA	NA	NA	NA	NA	NA	P	P	P	P	P
107	Pt100 2-wire in bearings.	NA	NA	NA	NA	NA	NA	P	P	P	P	P	P	P	P	P	P
128	Double PT100, 2-wire in bearings	NA	NA	NA	NA	NA	NA	NA	NA	NA	NA	NA	P	P	P	P	P
129	Double PT100, 3-wire in bearings	NA	NA	NA	NA	NA	NA	NA	NA	NA	NA	NA	P	P	P	P	P
130	Pt100 3-wire in bearings.	NA	NA	NA	NA	NA	NA	NA	NA	NA	NA	NA	P	P	P	P	P
188	63-series bearings.	M	M	M	M	M	M	S	S	S	S	S	S	S	S	S	S
194	2Z bearings greased for life at both ends.	S	S	S	S	S	S	M	M	M	M	M	NA	NA	NA	NA	NA
420	Bearing mounted PTC thermistors.	NA	NA	NA	NA	NA	NA	NA	NA	NA	NA	NA	P	P	P	P	P
433	Outlet grease collector	NA	NA	NA	NA	NA	NA	NA	NA	NA	NA	NA	P	P	P	P	P
506	Nipples for vibration measurement : SKF Marlin Quick Connect stud CMSS-2600-3	NA	NA	NA	NA	NA	NA	NA	NA	NA	NA	NA	P	P	P	P	P
654	Provision for vibration sensors (M8 x 1)	NA	NA	NA	NA	NA	NA	NA	NA	NA	NA	NA	P	P	P	P	P
796	Grease nipples JIS B 1575 PT 1/8 Type A	NA	NA	NA	NA	NA	NA	M	M	M	M	M	P	P	P	P	P
797	Stainless steel SPM nipples	M	M	M	M	M	M	M	M	M	M	M	P	P	P	P	P
798	Stainless steel grease nipples	M	M	M	M	M	M	M	M	M	M	M	P	P	P	P	P
799	Grease nipples flat type DIN 3404, thread M10 x 1	NA	NA	NA	NA	NA	NA	NA	NA	NA	NA	NA	P	P	P	P	P
800	Grease nipples JIS B 1575 PT 1/8" pin type	NA	NA	NA	NA	NA	NA	NA	NA	NA	NA	NA	P	P	P	P	P
Brakes																	
412	Built-in brake.	NA	NA	NA	NA	NA	NA	R	R	R	R	R	R	R	R	R	R

S: Included as standard

P: New manufacture only

M: On modification for a stocked motor or on new manufacture; the number of variants per order may be limited.

R: On request

NA: Not applicable

Code/ Variant, M3BP	Frame size															
	71	80	90	100	112	132	160	180	200	225	250	280	315	355	400	450
Branch standard designs																
142	Manilla connection.	NA	NA	P	P	P	P	P	P	P	P	P	P	NA	NA	NA
172	Smoke venting specification, 300 °C, 1 hour, DOL use, class F300 according to EN 12101-3	NA	NA	NA	NA	NA	NA	NA	NA	NA	NA	NA	P	P	P	NA
173	Smoke venting specification, 200 °C, 2 hours, DOL use, class F200 according to EN 12101-3	NA	NA	NA	NA	NA	NA	NA	NA	NA	NA	NA	P	P	P	NA
174	Smoke venting specification, 400 °C, 2 hours, DOL use, class F400 according to EN 12101-3	NA	NA	NA	NA	NA	NA	NA	NA	NA	NA	NA	P	P	P	NA
178	Stainless steel / acid proof bolts.	M	M	M	M	M	M	M	M	M	M	P	P	P	P	P
204	Jacking bolts for foot mounted motors.	NA	NA	NA	NA	NA	NA	NA	NA	NA	NA	NA	P	P	S	S
209	Non-standard voltage or frequency, (special winding).	P	P	P	P	P	P	P	P	P	P	P	P	P	P	P
386	Smoke venting specification, 200 °C, 2 hours, VSD use, Class F200 according to EN 12101-3.	NA	NA	NA	NA	NA	NA	NA	NA	NA	NA	NA	P	P	P	NA
387	Smoke venting specification, 300 °C, 1 hour, VSD use, Class F300 according to EN 12101-3	NA	NA	NA	NA	NA	NA	NA	NA	NA	NA	NA	P	P	P	NA
389	Smoke Venting specification, 400 °C, 2 hours, VSD use, Class F400 according to EN 12101-3	NA	NA	NA	NA	NA	NA	NA	NA	NA	NA	NA	P	P	P	NA
392	Smoke Venting specification, 250 °C, 2 hours, DOL use, Class T250	NA	NA	NA	NA	NA	NA	NA	NA	NA	NA	NA	P	P	P	NA
393	Smoke venting specification, 250 °C, 2 hours, VSD use, Class T250	NA	NA	NA	NA	NA	NA	NA	NA	NA	NA	NA	P	P	P	NA
396	Motor designed for ambient temperature -20 °C to -40 °C, with space heaters (code 450/451 must be added)	NA	NA	NA	NA	NA	P	P	P	P	P	P	P	P	P	P
397	Motor designed for ambient temperature -40 °C to -55 °C, with space heaters (code 450/451 must be added)	NA	NA	NA	NA	NA	NA	NA	NA	NA	NA	NA	P	P	P	P
398	Motor designed for ambient temperature -20 °C to -40 °C	NA	NA	NA	NA	NA	P	P	P	P	P	P	P	P	P	P
399	Motor designed for ambient temperature -40 °C to -55 °C	NA	NA	NA	NA	NA	NA	NA	NA	NA	NA	NA	P	P	P	P
425	Corrosion protected stator and rotor core.	M	M	M	M	M	P	P	P	P	P	P	P	P	P	P
Cooling system																
044	Unidirectional fan for reduced noise level. Rotation clockwise seen from D-end. Available only for 2-pole motors.	NA	NA	NA	NA	NA	NA	NA	NA	NA	NA	NA	P	P	P	P
045	Unidirectional fan for reduced noise level. Rotation counter clockwise seen from D-end. Available only for 2-pole motors.	NA	NA	NA	NA	NA	NA	NA	NA	NA	NA	NA	P	P	P	P
068	Light alloy metal fan	M	M	M	M	M	M	M	M	M	M	P	P	P	P	P
075	Cooling method IC418 (without fan).	P	P	P	P	P	P	P	P	P	P	P	P	P	P	P
183	Separate motor cooling (fan axial, N-end).	M	M	M	M	M	M	M	M	M	M	P	P	P	P	P
206	Steel fan	NA	NA	NA	NA	NA	NA	NA	NA	NA	NA	NA	P	P	P	NA
422	Separate motor cooling (on top) with integrated fan motor	NA	NA	NA	NA	NA	NA	NA	NA	NA	NA	NA	P	P	P	P
514	Separate motor cooling (fan on top)	NA	NA	NA	NA	NA	NA	NA	NA	NA	NA	NA	P	P	P	P
791	Stainless steel fan cover	NA	NA	NA	NA	NA	NA	NA	NA	NA	NA	NA	P	P	P	P
Coupling																
035	Assembly of customer supplied coupling-half.	NA	NA	NA	NA	NA	NA	NA	NA	NA	NA	NA	P	P	P	P
Documentation																
141	Binding dimension drawing.	M	M	M	M	M	M	M	M	M	M	P	P	P	P	P
Drain holes																
065	Plugged existing drain holes.	M	M	M	M	M	M	M	M	M	M	P	P	P	P	P
448	Draining holes with metal plugs.	NA	NA	NA	NA	NA	NA	NA	NA	NA	NA	NA	P	P	P	P
Earthing Bolt																
067	External earthing bolt.	M	M	M	M	M	S	S	S	S	S	S	S	S	S	S
Heating elements																
450	Heating element, 100-120 V	M	M	M	M	M	M	M	M	M	M	P	P	P	P	P
451	Heating element, 200 - 240 V	M	M	M	M	M	M	M	M	M	M	P	P	P	P	P
Insulation system																
014	Winding insulation class H.	P	P	P	P	P	P	P	P	P	P	P	P	P	P	P

S: Included as standard
P: New manufacture only
M: On modification for a stocked motor or on new manufacture; the number of variants per order may be limited.
R: On request
NA: Not applicable

Code/ Variant, M3BP	Frame size															
	71	80	90	100	112	132	160	180	200	225	250	280	315	355	400	450
405	P	P	P	P	P	P	P	P	P	P	P	P	P	P	P	P
406	NA	NA	NA	NA	NA	NA	NA	NA	P	P	P	P	P	P	P	P
Marine																
024	M	M	M	M	M	M	P	P	P	P	P	P	P	P	P	P
025	M	M	M	M	M	M	P	P	P	P	P	P	P	P	P	P
026	M	M	M	M	M	M	P	P	P	P	P	P	P	P	P	P
027	M	M	M	M	M	M	P	P	P	P	P	P	P	P	P	P
049	M	M	M	M	M	M	P	P	P	P	P	P	P	P	P	P
050	NA	NA	NA	NA	NA	NA	P	P	P	P	P	P	P	P	P	P
051	NA	NA	NA	NA	NA	NA	P	P	P	P	P	P	P	P	P	P
096	M	M	M	M	M	M	M	M	M	M	M	P	P	P	P	P
186	M	M	M	M	M	M	M	M	M	M	M	P	P	P	P	P
481	NA	NA	NA	NA	NA	NA	P	P	P	P	P	P	P	P	P	P
483	NA	NA	NA	NA	NA	NA	P	P	P	P	P	P	P	P	P	P
484	NA	NA	NA	NA	NA	NA	P	P	P	P	P	P	P	P	P	P
491	NA	NA	NA	NA	NA	NA	M	M	M	M	M	P	P	P	P	P
492	M	M	M	M	M	M	M	M	M	M	M	P	P	P	P	P
493	NA	NA	NA	NA	NA	NA	M	M	M	M	M	P	P	P	P	P
494	NA	NA	NA	NA	NA	NA	M	M	M	M	M	P	P	P	P	P
496	M	M	M	M	M	M	M	M	M	M	M	P	P	P	P	P
675	M	M	M	M	M	M	M	M	M	M	M	P	P	P	P	P
676	M	M	M	M	M	M	M	M	M	M	M	P	P	P	P	P
Mounting arrangements																
008	M	M	M	M	M	M	NA	NA	NA	NA	NA	NA	NA	NA	NA	NA
009	M	M	M	M	M	M	M	M	M	M	M	P	P	P	P	P
047	M	M	M	M	M	M	NA	NA	NA	NA	NA	NA	NA	NA	NA	NA
066	M	M	M	M	M	M	M	M	M	M	M	P	P	P	P	P
305	NA	NA	NA	NA	NA	NA	M	M	M	M	M	P	P	P	P	P
Noise reduction																
055	NA	NA	NA	NA	NA	NA	NA	NA	NA	NA	NA	NA	P	P	P	P
Painting																
105	NA	NA	NA	NA	NA	NA	NA	NA	NA	NA	NA	NA	P	P	P	P
106	NA	NA	NA	NA	NA	NA	NA	NA	NA	NA	NA	NA	S	S	S	S
114	M	M	M	M	M	M	M	M	M	M	M	P	P	P	P	P
115	NA	NA	NA	NA	NA	NA	NA	NA	NA	NA	NA	NA	P	P	P	P
168	P	P	P	P	P	P	NA	NA	NA	NA	NA	NA	P	P	P	P
179	R	R	R	R	R	R	R	R	R	R	R	R	R	R	R	R
710	P	P	P	P	P	P	NA	NA	NA	NA	NA	NA	P	P	P	P
711	P	P	P	P	P	P	P	P	P	P	P	P	P	P	P	P
754	NA	NA	NA	NA	NA	NA	NA	NA	NA	NA	NA	NA	P	P	P	P
Protection																

- S: Included as standard
- P: New manufacture only
- M: On modification for a stocked motor or on new manufacture; the number of variants per order may be limited.
- R: On request
- NA: Not applicable

Code/ Variant, M3BP	Frame size															
	71	80	90	100	112	132	160	180	200	225	250	280	315	355	400	450
005 Protective roof, vertical motor, shaft down.	M	M	M	M	M	M	M	M	M	M	M	P	P	P	P	P
072 Radial seal at D-end. Not possible for 2-pole, 280 and 315 frames	M	M	M	M	M	M	M	M	M	M	M	P	P	NA	NA	NA
073 Sealed against oil at D-end.	NA	NA	NA	NA	NA	NA	M	M	M	M	M	P	P	P	P	P
076 Draining holes with plugs in open position.	NA	NA	NA	NA	NA	NA	NA	NA	NA	NA	NA	S	S	S	S	S
158 Degree of protection IP65.	M	M	M	M	M	M	M	M	M	M	M	P	P	P	P	NA
211 Weather protected, IP xx W	M	M	M	M	M	M	M	M	M	M	M	NA	NA	NA	NA	NA
250 Degree of protection IP66	P	P	P	P	P	P	P	P	P	P	P	P	P	P	P	NA
401 Protective roof, horizontal motor.	NA	NA	NA	NA	NA	NA	NA	NA	NA	NA	NA	P	P	P	P	P
403 Degree of protection IP56.	M	M	M	M	M	M	M	M	M	M	M	P	P	P	P	NA
404 Degree of protection IP56, without fan and fan cover.	P	P	P	P	P	P	P	P	P	P	P	R	R	R	NA	NA
434 Degree of protection IP56, open deck.	NA	NA	NA	NA	NA	NA	NA	NA	NA	NA	NA	P	P	P	P	R
520 Motor protection cover made of glass fiber. Vertical motor, shaft down.	NA	NA	NA	NA	NA	NA	NA	NA	NA	NA	NA	P	P	P	P	NA
783 Labyrinth sealing at D-end.	NA	NA	NA	NA	NA	NA	P	P	P	P	P	P	P	S	S	S
784 Gamma-seal at D-end.	M	M	M	M	M	M	S	S	S	S	S	NA	NA	NA	NA	NA
Rating & instruction plates																
002 Restamping voltage, frequency and output, continuous duty.	M	M	M	M	M	M	M	M	M	M	M	P	P	P	P	P
003 Individual serial number.	NA	NA	NA	NA	NA	NA	S	S	S	S	S	S	S	S	S	S
004 Additional text on std rating plate (max 12 digits on free text line).	NA	NA	NA	M	M	M	M	M	M	M	M	P	P	P	P	P
095 Restamping output (maintained voltage, frequency), intermittent duty.	M	M	M	M	M	M	M	M	M	M	M	P	P	P	M	M
098 Stainless rating plate.	M	M	M	M	M	M	S	S	S	S	S	S	S	S	S	S
126 Tag plate	NA	NA	NA	NA	NA	NA	NA	NA	NA	NA	NA	P	P	P	P	P
135 Mounting of additional identification plate, stainless.	M	M	M	M	M	M	M	M	M	M	M	P	P	P	P	P
138 Mounting of additional identification plate, aluminium.	M	M	M	M	M	M	NA	NA	NA	NA	NA	NA	NA	NA	NA	NA
139 Additional identification plate delivered loose.	M	M	M	M	M	M	M	M	M	M	M	P	P	P	P	P
159 Additional plate with text "Made in"	M	M	M	M	M	M	M	M	M	M	M	P	P	P	P	P
160 Additional rating plate affixed.	M	M	M	M	M	M	M	M	M	M	M	P	P	P	P	P
161 Additional rating plate delivered loose.	M	M	M	M	M	M	M	M	M	M	M	P	P	P	P	P
163 Frequency converter rating plate. Rating data according to quotation.	M	M	M	M	M	M	M	M	M	M	M	P	P	P	P	P
360 Cargotec rating plate	NA	NA	NA	NA	NA	NA	P	P	P	P	P	P	P	P	P	P
Shaft & rotor																
069 Two shaft extensions as per basic catalogue.	P	P	P	P	P	P	P	P	P	P	P	P	P	P	P	P
070 Special shaft extension at D-End, standard shaft material	NA	P	P	P	P	P	P	P	P	P	P	P	P	P	P	P
131 Motor delivered with half key (key not exceeding shaft diameter)	M	M	M	M	M	M	M	M	M	M	M	NA	NA	NA	NA	NA
164 Shaft extension with closed keyway	S	S	S	S	S	S	S	S	S	S	S	P	P	P	P	R
165 Shaft extension with open keyway	NA	NA	NA	NA	NA	NA	P	P	P	P	P	S	S	S	S	S
410 Shaft material stainless steel	P	P	P	P	P	P	R	R	R	R	R	P	P	P	P	P
600 Special shaft extension at N-end, standard shaft material.	P	P	P	P	P	P	P	P	P	P	P	P	P	P	P	P
Standards and Regulations																
010 Fulfilling CSA Safety Certificate.	NA	NA	NA	NA	NA	NA	M	M	M	M	M	P	P	P	P	P
151 Design according to SHELL DEP 33.66.05.31-Gen. June 2007	NA	NA	NA	NA	NA	NA	NA	NA	NA	NA	NA	P	P	P	P	NA
242 Fulfilling CSA Energy Efficiency Verification IE2 (code 010 included)	NA	NA	NA	NA	NA	NA	P	P	P	P	P	NA	NA	NA	NA	NA
408 Fulfilling EISA Subtype II efficiency requirements, CC031A.	NA	NA	NA	NA	NA	NA	P	P	P	P	P	P	P	NA	NA	NA
500 Fulfilling Korean MEPS efficiency regulations	NA	NA	NA	NA	NA	NA	P	P	P	P	P	P	P	P	NA	NA
540 China energy label	NA	NA	NA	NA	NA	NA	P	P	P	P	P	P	P	P	NA	NA
542 NBR design	NA	NA	NA	NA	NA	NA	P	P	P	P	P	P	P	P	NA	NA
543 Australian MEPS	NA	P	P	P	P	P	P	P	P	P	P	P	P	P	NA	NA
778 GOST Export/Import Certificate (Russia).	NA	P	P	P	P	P	M	M	M	M	M	P	P	P	P	P
779 SASO Export/Import Certificate (Saudi Arabia)	NA	NA	NA	NA	NA	NA	NA	NA	NA	NA	NA	P	P	P	P	P
802 GOST Kazakhstan certified	NA	NA	NA	NA	NA	NA	NA	NA	NA	NA	NA	P	P	P	P	P
Stator winding temperature sensors																
120 KTY 84-130 (1 per phase) in stator winding.	NA	NA	NA	NA	NA	NA	P	P	P	P	P	P	P	P	P	P

S: Included as standard
P: New manufacture only
M: On modification for a stocked motor or on new manufacture; the number of variants per order may be limited.
R: On request
NA: Not applicable

Code/ Variant, M3BP	Frame size															
	71	80	90	100	112	132	160	180	200	225	250	280	315	355	400	450
121 Bimetal detectors, break type (NCC), (3 in series), 130 °C, in stator winding	M	M	M	M	M	M	M	M	M	M	M	P	P	P	P	P
122 Bimetal detectors, break type (NCC), (3 in series), 150 °C, in stator winding	M	M	M	M	M	M	M	M	M	M	M	P	P	P	P	P
123 Bimetal detectors, break type (NCC), (3 in series), 170 °C, in stator winding	M	M	M	M	M	M	M	M	M	M	M	P	P	P	P	P
124 Bimetal detectors, break type (NCC), (3 in series), 140 °C, in stator winding	NA	NA	NA	NA	NA	NA	M	M	M	M	M	P	P	P	P	P
125 Bimetal detectors, break type (NCC), (2 × 3 in series), 150 °C, in stator winding	NA	NA	NA	NA	NA	NA	M	M	M	M	M	P	P	P	P	P
127 Bimetal detectors, break type (NCC), (3 in series, 130 °C & 3 in series, 150 °C), in stator winding	M	M	M	M	M	M	M	M	M	M	M	P	P	P	P	P
435 PTC - thermistors (3 in series), 130 °C, in stator winding	M	M	M	M	M	M	M	M	M	M	M	P	P	P	P	P
436 PTC - thermistors (3 in series), 150 °C, in stator winding	S	S	S	S	S	S	S	S	S	S	S	S	S	S	S	S
437 PTC - thermistors (3 in series), 170 °C, in stator winding	M	M	M	M	M	M	M	M	M	M	M	P	P	P	P	P
438 PTC - thermistors (3 in series), 190 °C, in stator winding	NA	NA	NA	NA	NA	NA	NA	NA	NA	NA	NA	P	P	P	P	P
439 PTC - thermistors (2 × 3 in series), 150 °C, in stator winding	M	M	M	M	M	M	M	M	M	M	M	P	P	P	P	P
441 PTC - thermistors (3 in series, 130 °C & 3 in series, 150 °C), in stator winding	M	M	M	M	M	M	M	M	M	M	M	P	P	P	P	P
442 PTC - thermistors (3 in series, 150 °C & 3 in series, 170 °C), in stator winding	M	M	M	M	M	M	P	P	P	P	P	P	P	P	P	P
445 Pt100 2-wire in stator winding, 1 per phase	M	M	M	M	M	M	M	M	M	M	M	P	P	P	P	P
446 Pt100 2-wire in stator winding, 2 per phase	NA	NA	NA	NA	NA	NA	M	M	M	M	M	P	P	P	P	P
502 Pt100 3-wire in stator winding, 1 per phase	NA	NA	NA	NA	NA	NA	NA	NA	NA	NA	NA	P	P	P	P	P
503 Pt100 3-wire in stator winding, 2 per phase	NA	NA	NA	NA	NA	NA	NA	NA	NA	NA	NA	P	P	P	P	P
511 PTC thermistors (2 × 3 in series), 130 °C, in stator winding	NA	NA	NA	NA	NA	NA	NA	NA	NA	NA	NA	P	P	P	P	P
Terminal box																
015 Motor supplied in D connection.	M	M	M	M	M	M	M	M	M	M	M	NA	NA	NA	NA	NA
017 Motor supplied in Y connection.	M	M	M	M	M	M	M	M	M	M	M	NA	NA	NA	NA	NA
019 Larger than standard terminal box.	P	P	P	P	P	P	NA	NA	NA	NA	NA	P	P	P	P	NA
020 Detached terminal box.	NA	NA	NA	NA	NA	NA	NA	NA	NA	NA	NA	P	P	P	P	P
021 Terminal box LHS (seen from D-end).	P	P	P	P	P	P	P	P	P	P	P	P	P	P	P	NA
022 Cable entry LHS (seen from D-end).	P	P	P	P	P	P	M	M	M	M	M	P	P	P	P	P
157 Terminal box degree of protection IP65.	NA	NA	NA	NA	NA	NA	M	M	M	M	M	P	P	P	P	NA
180 Terminal box RHS (seen from D-end).	P	P	P	P	P	P	P	P	P	P	P	P	P	P	P	NA
230 Standard metal cable glands.	M	M	M	M	M	M	M	M	M	M	M	S	S	S	S	S
231 Standard cable glands with clamping device.	NA	NA	NA	NA	NA	NA	NA	NA	NA	NA	NA	P	P	P	P	P
277 Cable sealing end unit, size small for C-opening	NA	NA	NA	NA	NA	NA	NA	NA	NA	NA	NA	P	NA	NA	NA	NA
278 Cable sealing end unit, size medium for D-opening	NA	NA	NA	NA	NA	NA	NA	NA	NA	NA	NA	NA	P	P	P	P
279 Cable sealing end unit, size large for D-opening	NA	NA	NA	NA	NA	NA	NA	NA	NA	NA	NA	NA	P	P	P	P
292 Adapter C-C	NA	NA	NA	NA	NA	NA	NA	NA	NA	NA	NA	P	NA	NA	NA	NA
293 Adapter D-D	NA	NA	NA	NA	NA	NA	NA	NA	NA	NA	NA	NA	P	P	NA	NA
294 Adapter E-D	NA	NA	NA	NA	NA	NA	NA	NA	NA	NA	NA	NA	P	P	P	NA
295 Adapter E-2D	NA	NA	NA	NA	NA	NA	NA	NA	NA	NA	NA	NA	P	P	P	S
296 Adapter E-3D	NA	NA	NA	NA	NA	NA	NA	NA	NA	NA	NA	NA	NA	NA	NA	P
375 Standard plastic cable gland	M	M	M	M	M	M	NA	NA	NA	NA	NA	NA	NA	NA	NA	NA
380 Separate terminal box for temperature detectors, std. material	NA	NA	NA	NA	NA	NA	NA	NA	NA	NA	NA	P	P	P	P	P
400 4 × 90 degr turnable terminal box.	NA	NA	NA	NA	NA	NA	S	S	S	S	S	S	S	S	S	NA
402 Terminal box adapted for AI cables.	NA	NA	NA	NA	NA	NA	NA	NA	NA	NA	NA	S	S	S	S	S
413 Extended cable connection, no terminal box.	NA	NA	NA	NA	NA	NA	NA	NA	NA	NA	NA	P	P	P	P	P
418 Separate terminal box for auxiliaries, standard material.	P	P	P	P	P	P	M	M	M	M	M	P	P	P	P	P
444 Adapter E-2E	NA	NA	NA	NA	NA	NA	NA	NA	NA	NA	NA	NA	NA	NA	NA	P
447 Top mounted separate terminal box for monitoring equipment.	NA	NA	NA	NA	NA	NA	NA	NA	NA	NA	NA	P	P	P	P	P
466 Terminal box at N-end.	NA	NA	NA	NA	NA	NA	NA	NA	NA	NA	NA	P	P	P	P	P
467 Lower than standard terminal box and rubber extended cable. Cable length 2 m	NA	NA	NA	NA	NA	NA	P	P	P	P	P	NA	NA	NA	NA	NA
468 Cable entry from D-end.	M	M	M	M	M	M	R	R	R	R	R	P	P	P	P	NA

S: Included as standard
P: New manufacture only
M: On modification for a stocked motor or on new manufacture; the number of variants per order may be limited.
R: On request
NA: Not applicable

Code/ Variant, M3BP	Frame size															
	71	80	90	100	112	132	160	180	200	225	250	280	315	355	400	450
469 Cable entry from N-end.	M	M	M	M	M	M	M	M	M	M	M	P	P	P	P	NA
567 Separate terminal box material: cast Iron	NA	NA	NA	NA	NA	NA	S	S	S	S	S	P	P	P	P	P
568 Separate terminal box for heating elements, std. material	NA	NA	NA	NA	NA	NA	NA	NA	NA	NA	NA	P	P	P	P	P
569 Separate terminal box for brakes	NA	NA	NA	NA	NA	NA	NA	NA	NA	NA	NA	P	P	P	P	P
729 Aluminum non-drilled flange for cable glands	NA	NA	NA	NA	NA	NA	M	M	M	M	M	P	P	P	P	P
730 Prepared for NPT cable glands	M	M	M	M	M	M	NA	NA	NA	NA	NA	P	P	P	P	P
731 Two standard metal cable glands.	M	M	M	M	M	M	M	M	M	M	M	S	S	S	S	S
732 Standard cable gland, Ex d IIB, armoured cable.	NA	NA	NA	NA	NA	NA	NA	NA	NA	NA	NA	P	P	P	P	P
740 Prepared for PG cable glands.	NA	NA	NA	NA	NA	NA	M	M	M	M	M	NA	NA	NA	NA	NA
742 Protective cover for accessory terminal block in main terminal box.	NA	NA	NA	NA	NA	NA	NA	NA	NA	NA	NA	P	P	P	P	P
743 Painted non-drilled flange in steel for cable glands	NA	NA	NA	NA	NA	NA	M	M	M	M	M	P	P	P	P	P
744 Stainless steel non-drilled flange for cable glands.	NA	NA	NA	NA	NA	NA	NA	NA	NA	NA	NA	P	P	P	P	P
745 Painted steel flange equipped with nickle plated brass cable glands	NA	NA	NA	NA	NA	NA	NA	NA	NA	NA	NA	P	P	P	P	P
746 Stainless steel cable flange equipped with standard nickle plated brass cable glands	NA	NA	NA	NA	NA	NA	NA	NA	NA	NA	NA	P	P	P	P	P
753 Cast iron terminal box	NA	NA	NA	NA	NA	NA	S	S	S	S	S	S	S	S	S	S
Testing																
140 Test confirmation.	S	S	S	S	S	S	M	M	M	M	M	NA	NA	NA	NA	NA
145 Type test report from a catalogue motor, 400V 50Hz.	M	M	M	M	M	M	M	M	M	M	M	P	P	P	P	P
146 Type test with report for one motor from specific delivery batch.	NA	P	P	P	P	P	M	M	M	M	M	P	P	P	P	P
148 Routine test report.	M	M	M	M	M	M	M	M	M	M	M	P	P	P	P	P
149 Test according to separate test specification.	NA	NA	NA	NA	NA	NA	NA	NA	NA	NA	NA	R	R	R	R	R
150 Customer witnessed testing. Specify test procedure with other codes.	P	P	P	P	P	P	P	P	P	P	P	P	P	P	P	P
153 Reduced test for classification society.	NA	NA	NA	NA	NA	NA	M	M	M	M	M	NA	NA	NA	NA	NA
221 Type test and multi-point load test with report for one motor from specific delivery batch.	NA	NA	NA	NA	NA	NA	NA	NA	NA	NA	NA	R	R	R	R	R
222 Torque/speed curve, type test and multi-point load test with report for one motor from specific delivery batch.	NA	P	P	P	P	P	M	M	M	M	M	P	P	P	P	P
760 Vibration level test	P	P	P	P	P	P	M	M	M	M	M	P	P	P	P	P
761 Vibration spectrum test for one motor from specific delivery batch.	NA	NA	NA	NA	NA	NA	P	P	P	P	P	P	P	P	P	P
762 Noise level test for one motor from specific delivery batch.	P	P	P	P	P	P	M	M	M	M	M	P	P	P	P	P
763 Noise spectrum test for one motor from specific delivery batch.	NA	NA	NA	NA	NA	NA	P	P	P	P	P	P	P	P	P	P
764 Test for one motor from specific delivery batch with ABB frequency converter available at ABB test field. ABB standard test procedure.	NA	NA	NA	NA	NA	NA	NA	NA	NA	NA	NA	P	P	P	P	P
Variable speed drives																
181 Rating plate with ABB standard loadability values for VSD operation. Other auxiliaries for VSD operation to be selected as necessary.	NA	NA	NA	NA	NA	NA	NA	NA	NA	NA	NA	P	P	P	P	P
429 Separate motor cooling (fan top, N-end) and 1024 pulse tacho (Leine & Linde 861) mounted.	NA	NA	NA	NA	NA	NA	NA	NA	NA	NA	NA	P	P	P	P	P
470 Prepared for hollow shaft pulse tacho (L&L equivalent).	NA	NA	NA	NA	NA	NA	M	M	M	M	M	P	P	P	P	P
472 1024 pulse tacho (L&L 861007455-1024).	NA	NA	NA	NA	P	P	M	M	M	M	M	P	P	P	P	P
473 2048 pulse tacho (L&L 861007455-2048).	NA	NA	NA	NA	P	P	M	M	M	M	M	P	P	P	P	P
474 Separate motor cooling (axial fan, N-end) and prepared for hollow shaft tacho (L&L equivalent)	NA	NA	NA	NA	NA	NA	M	M	M	M	M	P	P	P	P	P
476 Separate motor cooling (axial fan, N-end) and 1024 pulse tacho (L&L 861007455-1024)	NA	NA	NA	NA	NA	NA	M	M	M	M	M	P	P	P	P	P
477 Separate motor cooling (axial fan, N-end) and 2048 pulse tacho (L&L 861007455-2048)	NA	NA	NA	NA	NA	NA	M	M	M	M	M	P	P	P	P	P
478 Separate motor cooling (fan on top, N-end) and prepared for hollow shaft tacho (L&L equivalent)	NA	NA	NA	NA	NA	NA	NA	NA	NA	NA	NA	P	P	P	P	P
479 Mounting of other type of pulse tacho with shaft extension, tacho not included.	NA	NA	NA	NA	NA	NA	R	R	R	R	R	P	P	P	P	P
486 Separate motor cooling (fan top, N-end) and prepared for DC-tacho.	NA	NA	NA	NA	NA	NA	NA	NA	NA	NA	NA	P	P	P	P	P

S: Included as standard
P: New manufacture only
M: On modification for a stocked motor or on new manufacture; the number of variants per order may be limited.
R: On request
NA: Not applicable

Code/ Variant, M3BP	Frame size															
	71	80	90	100	112	132	160	180	200	225	250	280	315	355	400	450
510 Separate motor cooling (fan top, N-end) and 2048 pulse tacho (Leine & Linde 861) mounted.	NA	NA	NA	NA	NA	NA	NA	NA	NA	NA	NA	P	P	P	P	P
580 Separate motor cooling, IP44, 400 V, 50Hz (axial fan, N-end) and 1024 pulse tacho (L&L 503)	NA	NA	NA	NA	NA	NA	M	NA	NA	NA	NA	NA	NA	NA	NA	NA
582 1024 pulse tacho, GHK912-GBR-1024, BEI IDEACOD	NA	NA	NA	NA	NA	NA	NA	NA	NA	NA	NA	P	P	P	P	P
583 2048 pulse tacho, GHK912-GBR-2048, BEI IDEACOD	NA	NA	NA	NA	NA	NA	NA	NA	NA	NA	NA	P	P	P	P	P
658 Special tacho mounted, price category 1	NA	NA	NA	NA	NA	NA	NA	NA	NA	NA	NA	P	P	P	P	P
659 Special tacho mounted, price category 2	NA	NA	NA	NA	NA	NA	NA	NA	NA	NA	NA	P	P	P	P	P
660 Special tacho mounted, price category 3	NA	NA	NA	NA	NA	NA	NA	NA	NA	NA	NA	P	P	P	P	P
701 Insulated bearing at N-end.	NA	NA	NA	NA	NA	NA	M	M	M	M	M	P	P	P	P	P
704 EMC cable gland.	M	M	M	M	M	M	M	M	M	M	M	P	P	P	P	P
Y/D starting																
117 Terminals for Y/D start at both speeds (two speed windings).	NA	NA	NA	NA	NA	NA	P	P	P	P	P	P	P	R	R	R
118 Terminals for Y/D start at high speed (two speed windings).	NA	NA	NA	NA	NA	NA	NA	NA	NA	NA	NA	P	P	R	R	R
119 Terminals for Y/D start at low speed (two speed windings).	NA	NA	NA	NA	NA	NA	NA	NA	NA	NA	NA	P	P	R	R	R

- S: Included as standard
P: New manufacture only
M: On modification for a stocked motor or on new manufacture; the number of variants per order may be limited.
R: On request
NA: Not applicable

Mechanical design

Motor frame, drain holes and heating elements

Motor frame

The motor frame is made of cast iron, and the standard design includes cast iron feet, bearing housing, and terminal box. Integrated cast iron feet provide rigid mounting and minimize vibration.

Motors can be supplied for foot mounting, flange mounting, and combinations of these.

Drain holes

Motors that will be operated in very humid or wet environments, and especially under intermittent duty, should be provided with drain holes. The IM designation, such as IM 3031, determines the intended mounting arrangement for the motor.

Motor sizes 71 - 450 are fitted with drain holes and closable plugs. The plugs are open on delivery. When mounting the motors, ensure that the drain holes face downwards.

In the case of vertical mounting, the upper plug must be hammered home completely. In very dusty environments, both plugs should be hammered home.

When mounting arrangement differs from foot mounted IM B3, mention variant code 066 when ordering.

See variant codes 065 and 066 under the heading "Drain holes".

Heating elements

Heating elements are installed into windings to keep them free of corrosion in humid conditions. The required power of heating elements is shown in the table. You can order heating elements with variant code 450 or 451.

Motor size	71	80	90	100	112	132	160	180
Power (W)	8	8	25	25	25	25	25	50

Motor size	200	225	250	280	315	355	400	450
Power (W)	50	50	50	60	2×60	2×60	2×60	2×100

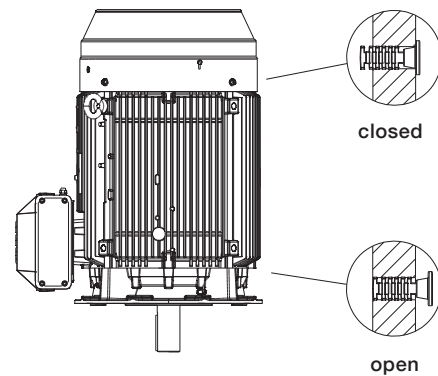
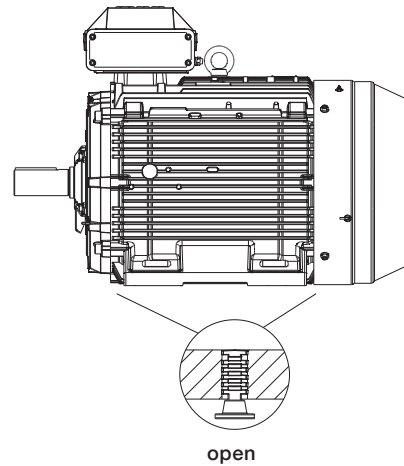

M000175

As standard, motor sizes 71 - 450 are delivered with drain holes and closable plugs.

Bearings

Process performance motors are normally fitted with single-row deep-groove ball bearings, as shown in the table below.

If the bearing at the D-end is replaced with a roller bearing (NU- or NJ-), higher radial forces can be handled. Roller bearings are suitable for belt-drive applications and can be ordered with variant code 037.

When high axial forces are involved, angular-contact ball bearings should be used. When ordering a motor with an angular-contact ball bearing, specify also the method of mounting and the direction and magnitude of axial force. The variant codes for ordering angular-contact ball bearings are 058 and 059.

Standard and alternative designs

Motor size	Number of poles	Standard design		Alternative designs		
		Deep groove ball bearings		Roller bearings (037)	Ang. contact ball bearings (058, 059)	
		D-end	N-end	D-end	D-end	N-end
71	2 - 8	6203-2Z/C3	6202-2Z/C3	NU 203 ECP/C3	7203 B	7202 B
80	2 - 8	6204-2Z/C3	6203-2Z/C3	NU 204 ECP/C3	7204 B	7203 B
90	2 - 8	6205-2Z/C3	6204-2Z/C3	NU 205 ECP/C3	7205 B	7204 B
100	2 - 8	6206-2Z/C3	6205-2Z/C3	NU 206 ECP/C3	7206 B	7205 B
112	2 - 8	6206-2Z/C3	6205-2Z/C3	NU 206 ECP/C3	7206 B	7205 B
132	2 - 8	6208-2Z/C3	6208-2Z/C3	NU 208 ECP/C3	7208 B	7208 B
160	2 - 12	6309/C3	6209/C3	NU 309 ECP/C3	7309 B	7209 B
180	2 - 12	6310/C3	6209/C3	NU 310 ECP/C3	7310 B	7209 B
200	2 - 12	6312/C3	6210/C3	NU 312 ECP/C3	7312 B	7210 B
225	2 - 12	6313/C3	6212/C3	NU 313 ECP/C3	7313 B	7212 B
250	2 - 12	6315/C3	6213/C3	NU 315 ECP/C3	7315 B	7213 B
280	2	6316/C3	6316/C3	¹⁾	7316 B	7616 B
	4 - 12	6316/C3	6316/C3	NU 316 ECP/C3	7316 B	7316 B
315	2	6316/C3	6316/C3	¹⁾	7316 B	7316 B
	4 - 12	6319/C3	6316/C3	NU 319 ECP/C3	7319 B	7316 B
355	2	6316M/C3	6316M/C3	¹⁾	7316 B	7316 B
	4 - 12	6322/C3	6316/C3	NU 322 ECP/C3	7322 B	7316 B
400	2	6317M/C3	6317M/C3	¹⁾	7317 B	7317 B
	4 - 12	6324/C3	6319/C3	NU 324 ECP/C3	7324 B	7319 B
450	2	6317M/C3	6317M/C3	¹⁾	7317 B	7317 B
	4 - 12	6326M/C3	6322/C3	NU 326 ECP/C3	7326 B	7322 B

¹⁾ On request

Axially-locked bearings

All motors are equipped as standard with an axially locked bearing at the D-end.

Transport locking

Motors with roller bearings or an angular-contact ball bearing are fitted with a transport lock before dispatch to prevent damage to bearings during transport. A warning sign is attached to motors larger than 250 when transport locking is used.

Locking may also be fitted in other cases if severe transport conditions are expected.

Bearing seals

These tables present the standard and alternative sizes and types of bearing seals per motor size.

Bearing seals for motor sizes 71 – 250

Motor size	Number of poles	Standard design		Alternative design
		Axial seal		Radial seal at D-end (DIN 3760)
		D-end	N-end	Variant code 072
71	2 - 12	VA16	Labyrinth seal	17×28×7
80	2 - 12	VA20	Labyrinth seal	20×40×7
90	2 - 12	VA25	Labyrinth seal	25×42×7
100	2 - 12	VA30	Labyrinth seal	30×47×7
112	2 - 12	VA30	Labyrinth seal	30×47×7
132	2 - 12	VA40	VA40	40×62×7
160	2 - 12	RB45	VA45	45×62×8
180	2 - 12	RB50	VA45	50×68×8
200	2 - 12	RB60	VA50	60×80×8
225	2 - 12	RB65	VA60	65×85×10
250	2 - 12	RB75	VA65	75×95×10

Bearing seals for motor sizes 280 - 450

Motor size	Number of poles	Standard design		Alternative design	
		D-end	N-end	D-end	N-end
280	2	Labyrinth seal	VS80	-	Labyrinth seal
280	4 - 12	VS80	VS80	Labyrinth seal	Labyrinth seal
	4 - 12			Radial seal 80×110×10	Radial seal 80×110×10
315	2	Labyrinth seal	VS80	-	Labyrinth seal
315 SM, ML	4 - 12	VS95	VS80	Labyrinth seal	Labyrinth seal
	4 - 12			Radial seal 95×125×10	Radial seal 80×110×10
315 LK	4 - 12	Labyrinth seal	VS80	-	Labyrinth seal
	4 - 12			-	Radial seal 80×110×10
355	2	Labyrinth seal	VS80	-	Labyrinth seal
355	4 - 12	Labyrinth seal	VS80	-	Labyrinth seal
400	2	Labyrinth seal	Labyrinth seal	-	-
400	4 - 12	Labyrinth seal	VS95	-	Labyrinth seal
450	2	Labyrinth seal	Labyrinth seal	-	-
450	4 - 12	Labyrinth seal	Labyrinth seal	-	-

Table is valid for IE2 motors

Axial seal:

RB45...75 = Gamma-ring
 VA16...65 = V-ring, type A
 VS80...95 = V-ring, type S

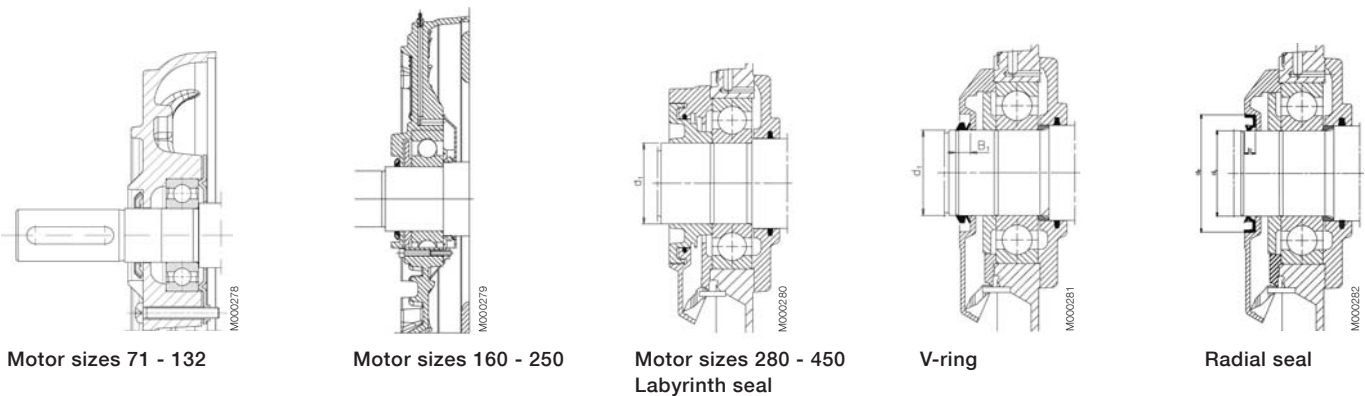

Motor sizes 71 - 132

Motor sizes 160 - 250

Motor sizes 280 - 450
Labyrinth seal

V-ring

Radial seal

Bearing life and lubrication

Bearing life

The nominal life L10h of a bearing is defined according to ISO 281 as the number of operating hours achieved or exceeded by 90 % of identical bearings in a large test series under specified conditions. 50 % of bearings achieve at least five times this lifetime.

The calculated bearing life L10h for power transmission by means of coupling is for horizontally mounted motors in sizes 280 to 315 \geq 200,000 hours.

Lubrication

On delivery, motors in frame size 160 and above are pre-lubricated with high-quality grease. Before first start-up, see instructions for relubrication and recommended grease in the Manual for low voltage motors delivered together with the motor, or see the lubrication plate on the motor.

Motors with bearings greased for life

Motors in frame sizes 71 - 132 are equipped with bearings greased for life, while this is available as an option for frame sizes 160 - 250. Bearings are lubricated with high-quality, high-temperature grease. Bearing types are stated on the rating plate.

The approximate lifetime of bearings in four-pole motors is about 40 000 duty hours. Lifetime is subject to the load conditions of the application run by the motor.

Lubrication intervals

ABB follows the L1 principle in defining lubrication intervals. This means that 99 % of motors will make the interval time.

The lubrication intervals can also be calculated according to the L10 principle, which usually gives twice as long interval times. L10 values are available from ABB at request.

Motors with relubrication nipples

In frame sizes 280 - 450, the bearing system allows the use of a valve disc to ease lubrication. Motors are lubricated while running.

The grease outlet opening has closing valves at both ends. These should be opened before greasing and closed 1 - 2 hours after regreasing. This ensures that the construction is tight and bearings remain dust- and dirt-free.

A grease-collection method can be used optionally.

The following tables show lubrication intervals according to the L1 principle for various nominal speeds in 25 °C ambient temperature. These values apply to horizontally mounted motors (B3) with 80 °C bearing temperature and high-quality grease containing lithium-complex soap and mineral or PAO-oil.

Lubrication intervals in duty hours for ball bearings

Frame size	Amount of grease g/bearing	Amount of grease g/N-end	Output kW	Speed 3600 r/min	Speed 3000 r/min	Output kW	Speed 1800 r/min	Speed 1500 r/min	Output kW	Speed 1000 r/min	Output kW	Speed 500-900 r/min
Ball bearings												
Lubrication intervals in duty hours												
160	13	13	≤ 18.5	9000	12 000	≤ 15	18 000	21 500	≤ 11	24 000	all	24 000
160	13	13	> 18.5	7500	10 000	> 15	15 000	18 000	> 11	22 500	all	24 000
180	15	15	≤ 22	7000	9000	≤ 22	15 500	18 500	≤ 15	24 000	all	24 000
180	15	15	> 22	6000	8500	> 22	14 000	17 000	> 15	21 000	all	24 000
200	20	15	≤ 37	5500	8000	≤ 30	14 500	17 500	≤ 22	23 000	all	24 000
200	20	15	> 37	3000	5500	> 30	10 000	12 000	> 22	16 000	all	20 000
225	23	20	≤ 45	4000	6500	≤ 45	13 000	16 500	≤ 30	22 000	all	24 000
225	23	20	> 45	1500	2500	> 45	5000	6000	> 30	8000	all	10 000
250	30	23	≤ 55	2500	4000	≤ 55	9000	11 500	≤ 37	15 000	all	18 000
250	30	23	> 55	1000	1500	> 55	3500	4500	> 37	6000	all	7000
280	35	35	all	1900	3200	-	-	-	-	-	-	-
280	40	40	-	-	-	all	7800	9600	all	13 900	all	15 000
315	35	35	all	1900	3200	-	-	-	-	-	-	-
315	55	40	-	-	-	all	5900	7600	all	11 800	all	12 900
355	35	35	all	1900	3200	-	-	-	-	-	-	-
355	70	40	-	-	-	all	4000	5600	all	9600	all	10 700
400	40	40	all	1500	2700	-	-	-	-	-	-	-
400	85	55	-	-	-	all	3200	4700	all	8600	all	9700
450	40	40	all	1500	2700	-	-	-	-	-	-	-
450	95	70	-	-	-	all	2500	3900	all	7700	all	8700

Lubrication intervals in duty hours for roller bearings

Frame size	Amount of grease g/bearing	Amount of grease g/N-end	Output kW	Speed 3600 r/min	Speed 3000 r/min	Output kW	Speed 1800 r/min	Speed 1500 r/min	Output kW	Speed 1000 r/min	Output kW	Speed 500-900 r/min
Roller bearings												
Lubrication intervals in duty hours												
160	13	13	≤ 18.5	4500	6000	≤ 15	9000	10 500	≤ 11	12 000	all	12 000
160	13	13	> 18.5	3500	5000	> 15	7500	9000	> 11	11 000	all	12 000
180	15	15	≤ 22	3500	4500	≤ 22	7500	9000	≤ 15	12 000	all	12 000
180	15	15	> 22	3000	4000	> 22	7000	8500	> 15	10500	all	12 000
200	20	15	≤ 37	2750	4000	≤ 30	7000	8500	≤ 22	11 500	all	12 000
200	20	15	> 37	1500	2500	> 30	5000	6000	> 22	8000	all	10 000
225	23	20	≤ 45	2000	3000	≤ 45	6500	8000	≤ 30	11 000	all	12 000
225	23	20	> 45	750	1250	> 45	2500	3000	> 30	4000	all	5000
250	30	23	≤ 55	1000	2000	≤ 55	4500	5500	≤ 37	7500	all	9000
250	30	23	> 55	500	750	> 55	1500	2000	> 37	3000	all	3500
280	35	35	all	900	1600	-	-	-	-	-	-	-
280	40	40	-	-	-	all	4000	5300	all	7000	all	8500
315	35	35	all	900	1600	-	-	-	-	-	-	-
315	55	40	-	-	-	all	2900	3800	all	5900	all	6500
355	35	35	all	900	1600	-	-	-	-	-	-	-
355	70	40	-	-	-	all	2000	2800	all	4800	all	5400
400	40	40	all	-	1300	-	-	-	-	-	-	-
400	85	55	-	-	-	all	1600	2400	all	4300	all	4800
450	40	40	all	-	1300	-	-	-	-	-	-	-
450	95	70	-	-	-	all	1300	2000	all	3800	all	4400

Radial forces

Pulley diameter

When the desired bearing life has been determined, the minimum permissible pulley diameter can be calculated with F_R as follows:

$$D = \frac{1.9 \cdot 10^7 \cdot K \cdot P}{n \cdot F_R}$$

Where:

D:	pulley diameter, mm
P:	power requirement, kW
n:	motor speed, r/min.
K:	belt tension factor, dependent on belt type and type of duty. A common value for V-belts is 2.5
F_R:	permissible radial force

Permissible loading on the shaft

The following table shows permissible radial forces on the shaft in Newtons, assuming zero axial force, a 25 °C ambient temperature, and normal conditions. The values are given for a calculated bearing life of 20 000 and 40 000 hours per motor size.

These calculated values further assume mounting position IM B3 (foot-mounted), with force directed sideways. In some cases, the strength of the shaft affects permissible forces.

Permissible loads of simultaneous radial and axial forces can be supplied on request.

If the radial force is applied between points X_0 and X_{max} , the permissible force F_R can be calculated with the following formula:

$$F_R = F_{X_0} - \frac{X}{E} (F_{X_0} - F_{X_{max}})$$

Where:

E:	length of the shaft extension in the standard version
-----------	---

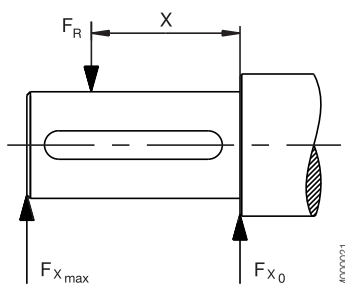

Permissible radial forces, motor sizes 71 – 132

Motor size	No. of poles	Length of shaft extension E (mm)	Basic design with deep groove ball bearings			
			20,000 h		40,000 h	
			F_{X_0} (N)	$F_{X_{max}}$ (N)	F_{X_0} (N)	$F_{X_{max}}$ (N)
71	2	30	540	460	370	310
	4	30	680	580	540	455
	6	30	780	655	620	525
	8	30	860	655	680	580
80	2	40	735	620	585	490
	4	40	925	780	735	615
	6	40	1060	865	840	710
	8	40	1165	870	925	780
90	2	50	805	660	590	485
	4	50	1015	835	805	660
	6	50	1160	955	920	760
	8	50	1280	1050	1015	835
100	2	60	860	695	365	295
	4	60	1410	1135	860	695
	6	60	1615	1300	1215	975
	8	60	1780	1430	1410	1135
112	2	60	870	715	365	300
	4	60	1425	1165	870	710
	6	60	1635	1335	1230	1005
	8	60	1800	1470	1425	1165
132	2	80	1720	1400	890	725
	4	80	2320	1890	1720	1400
	6	80	2655	2160	2105	1715
	8	80	2925	2380	2320	1890

Permissible radial forces, motor sizes 160 – 280

Motor size	Poles	Length of shaft extension E (mm)	Ball bearings				Roller bearings			
			20,000 h		40,000 h		20,000 h		40,000 h	
			F _{x0} (N)	F _{xmax} (N)	F _{x0} (N)	F _{xmax} (N)	F _{x0} (N)	F _{xmax} (N)	F _{x0} (N)	F _{xmax} (N)
160 MLA	2	110	3540	2740	2955	2285	7100	4300	6140	4300
	4	110	4000	3100	3325	2570	8000	4300	6870	4300
	6	110	4170	3200	3440	2655	8600	4300	7270	4300
	8	110	4600	3585	3855	2985	9300	4300	7955	4300
160 MLB	2	110	3540	2740	2955	2270	7085	4300	6070	4300
	4	110	4085	3300	3370	2725	8300	4300	7055	4300
	6	110	4100	3355	3400	2755	8600	4300	7300	4300
	8	110	4200	3270	3455	2670	9000	4300	7570	4300
160 MLC	2	110	3400	2600	2855	2200	6800	4300	5885	4300
	4	110	3700	3000	3070	2485	7800	4300	6640	4300
	6	110	3600	2900	2870	2325	8000	4300	6700	4300
	8	110	4170	3370	3370	2725	9000	4300	7585	4300
160 MLD	2	110	3585	2900	3000	2440	7100	4300	6140	4300
	4	110	3400	2755	2755	2240	7600	4300	6370	4300
160 MLE	2	110	3185	2570	2640	2140	6785	4300	5770	4300
180 MLA	2	110	4100	3385	3455	2825	8125	5500	7025	5500
	4	110	4270	3485	3525	2885	8600	5500	7300	5500
	6	110	4700	3800	3855	3155	9400	5500	7900	5500
	8	110	4785	3900	3870	3170	9800	5500	8255	5500
180 MLB	2	110	4170	3400	3470	2825	7900	5500	6770	5500
	4	110	4185	3400	3440	2810	8500	5500	7200	5500
	6	110	4370	3570	3525	2885	9000	5500	7600	5500
180 MLC	4	110	3700	3055	3010	2470	7900	5500	6655	5440
200 MLA	2	110	5600	4685	4700	3925	10 900	9100	9470	7900
	4	110	6285	5200	5240	4370	12 500	9550	10700	8900
	6	110	6800	5700	5700	4770	13 600	9550	11670	9550
	8	110	6800	5700	5600	4685	14 100	9550	12 000	9550
200 MLB	2	110	5670	4700	4700	3925	11 000	9200	9500	7900
	4	110	5700	4700	4700	3925	12 000	9550	10 185	8500
	6	110	6400	5370	5300	4425	13 200	9550	11 200	9385
200 MLC	2	110	5000	4185	4185	3500	10 400	8700	8900	7455
	4	110	5400	4500	4425	3685	11 600	9550	9800	8200
	6	110	5800	4885	4740	3955	12 500	9550	10 600	8800
200 MLD	2	110	4985	4170	4170	3485	10 400	8700	8900	7400
225 SMA	2	110	6400	5400	5355	4500	13 300	10 700	11 500	9700
	4	140	7300	5900	6155	4970	15 400	10 250	13 200	10 250
	6	140	7600	6200	6370	5140	16 400	10 250	14 000	10 250
	8	140	8500	6900	7100	5725	17 900	10 250	15 300	10 250
225 SMB	2	110	6100	5185	5155	4340	13 000	10 700	11 200	9455
	4	140	7085	5700	5885	4755	15 100	10 250	12 900	10 250
	6	140	7100	5700	5840	4700	16 000	10 250	13 500	10 250
	8	140	8000	6485	6600	5340	17 300	10 250	14 700	10 250
225 SMC	2	110	5600	4700	4685	3940	12 600	10 600	10 770	9070
	4	140	6400	5200	5300	4285	14 500	10 250	12 385	10 000
225 SMD	2	110	5500	4640	4600	3880	12 420	10 460	10 640	8960
	4	140	5800	4700	4725	3800	13 500	10 250	11 400	9270
250 SMA	2	140	7700	6285	6500	5285	17 100	10 900	14 900	10 900
	4	140	8700	7000	7300	5900	19 800	13 800	17 000	13 785
	6	140	9400	7600	7800	6355	21 600	13 800	18 400	13 800
	8	140	9600	7800	7900	6400	22 700	13 800	19 300	13 800
250 SMB	2	140	7100	5800	6000	4885	16 700	10 900	14 400	10 900
	4	140	7800	6300	6470	5240	18 900	13 800	16 200	13 100
	6	140	8900	7200	7355	5955	21 200	13 800	18 000	13 800
250 SMC	2	140	6800	5500	5670	4600	16 300	10 900	14 000	10 900
	4	140	7400	6000	6055	4900	18 100	13 800	15 400	12 485

Motor size	Poles	Length of shaft extension E (mm)	Ball bearings				Roller bearings			
			20,000 h		40,000 h		20,000 h		40,000 h	
			F _{x0} (N)	F _{xmax} (N)	F _{x0} (N)	F _{xmax} (N)	F _{x0} (N)	F _{xmax} (N)	F _{x0} (N)	F _{xmax} (N)
250 SMC	6	140	8200	6600	6670	5400	20 300	13 800	17 200	13 800
280 SM_	2	140	7300	6000	5800	4900	20 400	6000	16 500	6000
	4	140	9200	7800	7300	6200	25 100	9200	20300	9200
	6	140	10 600	8900	8400	7000	28 300	9200	23 000	9200
	8	140	11 700	9200	9200	7800	30 900	9200	25 100	9200
280 ML_	2	140	7400	6200	5800	5000	20 600	6200	16 700	6200
	4	140	9200	7900	7300	6200	25 000	9500	20 300	9500
	6	140	10 500	9000	8300	7100	28 300	9400	22 900	9400
	8	140	11 600	9500	9200	7900	30 800	9500	25 000	9500

Permissible radial forces, motor sizes 315 – 450

Motor size	Poles	Length of shaft extension E (mm)	Ball bearings				Roller bearings			
			20,000 h		40,000 h		20,000 h		40,000 h	
			F _{x0} (N)	F _{xmax} (N)	F _{x0} (N)	F _{xmax} (N)	F _{x0} (N)	F _{xmax} (N)	F _{x0} (N)	F _{xmax} (N)
315 SM_	2	140	7300	6000	5800	4950	20 300	6000	16 500	6000
	4	170	11 400	9400	9000	7450	32 500	9600	26 600	9600
	6	170	13 000	9600	10 300	8500	37 000	9600	30 000	9600
	8	170	14 400	9600	11 400	9400	40 300	9600	32 700	9600
315 ML_	2	140	7400	6400	5850	5050	20 600	5850	16 700	5850
	4	170	11 500	9700	9100	7650	32 700	13 600	26 500	13 600
	6	170	13 200	11 100	10 400	8800	36 900	13 600	29 900	13 600
	8	170	14 500	12 200	11 500	9700	40 200	13 600	32 600	13 600
315 LK_	2	140	7400	6550	5800	5150	20 800	5550	16 800	5550
	4	170	11 500	10 000	9100	7850	33 100	13 350	26 800	13350
	6	170	13 200	11 400	10 450	9050	37 300	13 350	30 300	13350
	8	170	14 600	12 600	11 550	10 000	40 800	13 350	33 100	13350
355 SM_	2	140	7350	6450	5750	5050	20 600	7200	16 700	7200
	4	210	15 200	12 600	12 000	9950	45 500	14 000	36 900	14 000
	6	210	17 500	14 000	13 800	11 400	51 400	14 000	41 700	14 000
	8	210	19 300	14 000	15 250	12 600	56 000	14 000	45 500	14 000
355 ML_	2	140	7350	6550	5750	5100	20 800	6750	16 800	6750
	4	210	15 300	12 900	12 000	10 100	45 900	13 600	37 200	13 600
	6	210	17 600	13 600	13 900	11 600	51 500	13 600	42 100	13 600
	8	210	19 400	13 600	15 300	12 900	56 000	13 600	45 900	13 600
355 LK_	2	140	7350	6650	5650	5100	21 000	6550	17 000	6550
	4	210	15 200	13 000	11 850	10 200	46 000	13 000	37300	13 000
	6	210	17 500	13 000	13 700	11 900	52 000	13 000	42 000	13 000
	8	210	19 400	13 000	15 200	13 000	56 500	13 000	46 000	13 000
400 L_	2	170	7650	6850	4400	3900	23 900	9050	19 350	9050
	4	210	15 600	13 550	12 150	10 550	52 500	16 000	43 300	16 000
	6	210	17 800	15 450	13 850	12 000	60 000	16 000	48 800	16 000
	8	210	19 700	16 000	15 350	13 350	65 700	16 000	53 200	16 000
400 LK_	2	170	7650	6850	4400	3900	23 900	9050	19 350	9050
	4	210	15 600	11 500	12 150	10 550	52 500	11 500	43 300	11 500
	6	210	17 800	11 500	13 850	11 500	60 000	11 500	48 800	11 500
	8	210	19 700	11 500	15 350	11 500	65 700	11 500	53 200	11 500
450 L_	2	170	7400	6700	3500	3300	24 000	7500	19 000	7500
	4	210	17 000	15 200	13 000	11 600	62 000	25 000	50 000	25 000
	6	210	19 000	17 000	14 000	13 000	70 000	24 000	56 000	24 000
	8	210	21 300	19 000	16 500	14 600	76 000	23 000	62 000	23 000

Axial forces

The following tables present permissible axial forces on the shaft in Newtons, assuming zero radial force, a 25 °C ambient temperature, and normal conditions. The values are given for a calculated bearing life of 20,000 and 40,000 hours per motor size.

At 60 Hz, the values must be reduced by 10 percent, and for two-speed motors, the higher speed determines permissible axial force. Permissible loads of simultaneous radial and axial forces can be supplied on request.

For axial force F_{AD} , it is assumed that the D-bearing is locked with a locking ring.

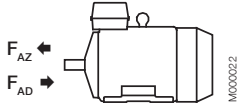

Mounting arrangement IM B3

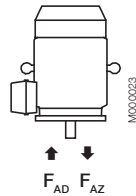

Mounting arrangement IM V1

Permissible axial forces, motor sizes 71 - 132

Motor size	Poles	Length of shaft extension E (mm)	Mounting arrangement IM B3				Mounting arrangement IM V1			
			Deep groove ball bearings				Deep groove ball bearings			
			20,000 h		40,000 h		20,000 h		40,000 h	
			$F_{AD}(N)$	$F_{AZ}(N)$	$F_{AD}(N)$	$F_{AZ}(N)$	$F_{AD}(N)$	$F_{AZ}(N)$	$F_{AD}(N)$	$F_{AZ}(N)$
71	2	30	635	265	525	155	650	255	535	145
	4	30	780	410	635	265	800	400	655	250
	6	30	890	520	715	345	915	505	740	330
	8	30	980	610	780	410	1005	595	805	395
80	2	40	805	380	655	230	835	360	685	210
	4	40	995	570	800	375	1050	535	855	340
	6	40	1140	715	910	485	1180	685	955	460
	8	40	1255	830	1000	575	1300	805	1040	545
90	2	50	890	390	730	230	940	355	780	195
	4	50	1095	595	885	385	1170	550	960	335
	6	50	1250	750	1000	500	1330	700	1080	450
	8	50	1375	875	1100	600	1445	835	1165	555
100	2	60	1410	360	1185	135	1485	310	1265	90
	4	60	1695	645	1405	355	1810	575	1515	280
	6	60	1910	860	1570	520	2005	800	1660	455
	8	60	2085	1035	1700	650	2180	975	1795	590
112	2	60	1410	360	1190	140	1480	315	1260	95
	4	60	1695	645	1400	350	1820	560	1525	265
	6	60	1905	855	1565	515	2035	775	1690	430
	8	60	2080	1030	1695	645	2195	960	1810	575
132	2	80	2065	665	1725	325	2210	570	1865	225
	4	80	2510	1110	2060	660	2710	985	2250	525
	6	80	2830	1430	2295	895	3100	1250	2565	715
	8	80	3105	1705	2505	1105	3335	1550	2740	955

Permissible axial forces, motor sizes 160 - 280

Motor size	Poles	Length of shaft extension E (mm)	Mounting arrangement IM B3				Mounting arrangement IM V1			
			Deep groove ball bearings				Deep groove ball bearings			
			20,000 h		40,000 h		20,000 h		40,000 h	
			F _{AD} (N)	F _{AZ} (N)	F _{AD} (N)	F _{AZ} (N)	F _{AD} (N)	F _{AZ} (N)	F _{AD} (N)	F _{AZ} (N)
160 MLA	2	110	2850	2850	2325	2325	3100	2578	2570	2048
	4	110	3450	3450	2775	2775	3820	3150	3120	2450
	6	110	3690	3690	2970	2970	4100	3410	3325	2635
	8	110	4155	4155	3315	3315	4440	3845	3640	3045
160 MLB	2	110	2850	2850	2325	2325	3120	2570	2580	2030
	4	110	3435	3435	2760	2760	3880	3085	3180	2385
	6	110	3600	3600	2880	2880	4120	3240	3360	2480
	8	110	3750	3750	2970	2970	4140	3450	3340	2650
160 MLC	2	110	2775	2775	2280	2280	3080	2500	2560	1980
	4	110	3150	3150	2535	2535	3620	2770	2985	2135
	6	110	3135	3135	2490	2490	3680	2700	3005	2025
	8	110	3675	3675	2910	2910	4240	3260	3445	2465
160 MLD	2	110	2865	2865	2330	2330	3220	2540	2665	1985
	4	110	2900	2900	2320	2320	3420	2470	2820	1870
160 MLE	2	110	2500	2500	2025	2025	2900	2150	2420	1670
180 MLA	2	110	3300	3300	2700	2700	3660	2940	3060	2340
	4	110	3600	3600	2920	2920	4160	3150	3460	2450
	6	110	4140	4140	3320	3320	4800	3675	3940	2815
	8	110	4220	4220	3360	3360	4960	3740	4040	2820
180 MLB	2	110	3340	3340	2725	2725	3760	2960	3125	2320
	4	110	3580	3580	2900	2900	4220	3095	3500	2375
	6	110	3800	3800	3040	3040	4500	3285	3700	2485
180 MLC	4	110	3220	3220	2560	2560	3880	2660	3220	2000
200 MLA	2	110	4460	4460	3640	3640	5000	3965	4200	3125
	4	110	5000	5260	4260	4260	5000	4680	5000	3640
	6	110	5000	5480	4720	4720	5000	5265	5000	4065
	8	110	5000	5880	4700	4700	5000	5195	5000	3955
200 MLB	2	110	4440	4440	3620	3620	5000	3905	4220	3085
	4	110	4720	4720	3840	3840	5000	4060	4700	3120
	6	110	5000	5480	4420	4420	5000	4800	5000	3660
200 MLC	2	110	3940	3940	3180	3180	4600	3385	3880	2665
	4	110	4480	4480	3620	3620	5000	3775	4520	2875
	6	110	4980	4980	3980	3980	5000	4165	5000	3105
200 MLD	2	110	3940	3940	3200	3200	4660	3370	3925	2635
225 SMA	2	110	4980	4980	4060	4060	5000	4375	4780	3455
	4	140	5000	6080	4920	4920	5000	5445	5000	4225
	6	140	5000	6520	5000	5260	5000	5735	5000	4395
	8	140	5000	7420	5000	5960	5000	6535	5000	5095
225 SMB	2	110	4860	4860	3960	3960	5000	4245	4780	3345
	4	140	5000	5880	4780	4780	5000	5175	5000	3995
	6	140	5000	6020	4840	4840	5000	5155	5000	3915
	8	140	5000	6940	5000	5560	5000	6055	5000	4635
225 SMC	2	110	4380	4380	3540	3540	5000	3670	4440	2900
	4	140	5000	5240	4260	4260	5000	4445	5000	3425
225 SMD	2	110	4320	4320	3480	3480	5000	3590	4400	2790
	4	140	4800	4800	3820	3820	5000	3895	5000	2935
250 SMA	2	140	6000	6080	4920	4920	6000	5345	5840	4225
	4	140	6000	7140	5820	5820	6000	6300	6000	4920
	6	140	6000	7880	6000	6380	6000	6950	6000	5350
	8	140	6000	8200	6000	6600	6000	7125	6000	5385
250 SMB	2	140	5620	5620	4540	4540	6000	4830	5640	3810
	4	140	6000	6320	5100	5100	6000	5325	6000	4085
	6	140	6000	7480	6000	6040	6000	6370	6000	4830

Motor size	Poles	Length of shaft extension E (mm)	Mounting arrangement IM B3				Mounting arrangement IM V1			
			Deep groove ball bearings				Deep groove ball bearings			
			20,000 h		40,000 h		20,000 h		40,000 h	
			$F_{AD}(N)$	$F_{AZ}(N)$	$F_{AD}(N)$	$F_{AZ}(N)$	$F_{AD}(N)$	$F_{AZ}(N)$	$F_{AD}(N)$	$F_{AZ}(N)$
250 SMC	2	140	5260	5260	4220	4220	6000	4395	5400	3415
	4	140	5960	5960	4760	4760	6000	4900	6000	3700
	6	140	6000	6860	5520	5520	6000	5575	6000	4135
280 SM_	2	140	6200	4250	4900	2900	7550	3150	6200	1800
	4	140	8000	6000	6250	4250	9600	4550	7800	2750
	6	140	7250	9250	7150	5150	11 150	5500	9000	3350
280 ML_	2	140	10 300	8300	7950	5950	12 200	7000	9850	4700
	4	140	6100	4100	4800	2800	8150	2750	6800	1400
	6	140	7800	5800	6000	4000	10 450	4050	8650	2250
280 ML_	2	140	8950	6950	6900	4900	12 350	4750	10 250	2600
	4	140	10 000	8000	7700	5700	13 450	5800	11 050	3450
	6	140								

Permissible axial forces, motor sizes 315 - 450

Motor size	Poles	Length of shaft extension E (mm)	Mounting arrangement IM B3				Mounting arrangement IM V1			
			Deep groove ball bearings				Deep groove ball bearings			
			20,000 h		40,000 h		20,000 h		40,000 h	
			$F_{AD}(N)$	$F_{AZ}(N)$	$F_{AD}(N)$	$F_{AZ}(N)$	$F_{AD}(N)$	$F_{AZ}(N)$	$F_{AD}(N)$	$F_{AZ}(N)$
315 SM_	2	140	6180	4200	4850	2850	7950	2600	6600	1300
	4	170	9400	7400	7250	5250	11 750	5500	9550	3300
	6	170	10 900	8900	8350	6350	13 600	6300	11 050	3750
	8	170	12 000	10 000	9200	7000	15 350	7900	12 450	5000
315 ML_	2	140	6050	4050	4750	2750	8650	2300	7300	-
	4	170	9250	7250	7100	5100	12 500	5050	10 300	2900
	6	170	10 650	8650	8100	6100	14 900	5800	12 350	3250
	8	170	11 500	9900	8900	6800	15 400	6300	13 600	3400
315 LK_	2	140	6000	3950	4650	2650	9100	1350	7750	-
	4	170	9100	7150	7000	5000	13 100	3850	10 900	1700
	6	170	10 500	8500	7950	5950	15 700	4100	13 100	1550
	8	170	11 750	9750	8900	6900	16 900	6300	14 100	3450
355 SM_	2	140	3050	6850	1750	5550	6350	4250	4950	2900
	4	210	8600	12 400	5900	9700	13250	8600	10 450	5850
	6	210	10 550	14 350	7300	11 100	15650	9580	12 350	6270
	8	210	12 200	16 000	8550	12 350	17350	12 500	13 600	8900
355 ML_	2	140	2900	6700	1600	5400	7100	3700	5750	2350
	4	210	8360	12 150	5650	9450	14 600	7950	11 850	5150
	6	210	10 100	13 900	6900	10 700	18 050	8600	14 700	5300
	8	210	12 000	15 800	7300	11 000	21 100	11 650	17 000	7600
355 LK_	2	140	2650	6450	1350	5150	8250	2650	6900	1300
	4	210	8200	12 000	5450	9250	15 650	6600	12 850	3800
	6	210	9900	13 700	6700	10 500	19 100	7050	15 800	3750
	8	210	11 450	15 250	7800	11 600	21 200	8700	17 500	5000
400 L, LK_	2	170	2150	7150	¹⁾	5800	8650	2150	7220	-
	4	210	7100	13 100	4300	10 300	16 050	6400	13 150	3400
	6	210	8850	14 850	5500	11 500	18 450	6750	15 100	3400
	8	210	10 450	16 450	6750	12 750	20 100	8350	16 450	4700
450 L_	2	170	1800	6800	¹⁾	5500	11 500	-	10 000	-
	4	210	7600	13 500	4500	10 500	20 000	4400	17 700	1200
	6	210	9000	15 000	5600	11 500	26 000	3700	22 200	-
	8	210	10 800	16 800	7000	12 900	27 800	5500	23 700	1350

¹⁾ The maximum lifetime of the grease is 27 000 h, see Grease lifetime.

Terminal box

Standard terminal box

Degree of protection and mounting options

The degree of protection for the standard terminal box is IP 55. By default, terminal boxes are mounted on top of the motor at D-end. In motor sizes 71 - 132, the terminal box is integrated in motor frame. On request, the terminal box can also be mounted on the left or right side regardless of motor size (see Mounting options).

Turnability

The standard terminal boxes for motor sizes 160 - 400 can be turned 4*90°. In sizes 71 to 132, turning is not possible in the standard motor, but 2*180° turning is available as an option (variant code 022).

Cable entries

In motor sizes 71 - 132, the terminal box has tapped holes with plugs for cable connections. Sizes 160 - 250 come with a connection flange with tapped cable entries, and can be provided with cable glands as an option.

Sizes 280 - 450 have a flange or cable sealing end units, depending on frame height and length. The standard flange material is aluminum.

Cable type and terminations

If no cable type is specified in the order, it will be a PVC-insulated non-armored cable, and its termination parts are determined as shown in the following table.

Terminations are suitable for copper and aluminum cables (Al-cables on request for motor sizes 160 to 250). Cables are connected to terminals by cable lugs, which are not included in the delivery.

Ordering

To ensure the delivery of desired terminations for the motor, state the cable type, quantity, size, and outer diameter when ordering. Non-standard designs of terminal boxes, such as non-standard size or higher degree of protection, are available as options.

See section Variant codes for all options available.

Standard delivery

Standard delivery if no other information is provided. Note: For other network voltages and/or side-mounted motors, contact your ABB sales office.

Motor size	Pole number	Terminal box	Terminal box opening	45° adapter (variant code)	Threaded holes	Cable gland	Cable sealing end unit (variant code)	Cable outer diameter mm	Single core cross-section mm ² /phase	Terminal bolt size 6 x
71	2-8	-	-	-	2xM16x1.5	-	-	Ø5-9	2.5	M4
80	2-8	-	-	-	2xM25x1.5	-	-	Ø11-16	4	M4
90	2-8	-	-	-	2xM32x1.5	-	-	Ø11-16	6	M5
100-132	2-8	-	-	-	2xM32x1.5	-	-	Ø14-21	10	M5
160-180	2-8	120	B	-	-	2xM40x1.5	-	2xØ19-27	1x35	M6
200-250	2-8	120	B	-	-	2xM63x1.5	-	2xØ34-45	1x70	M10
280 SM	2-8	210	C	-	2xM63x1.5	2xM63x1.5	-	2xØ32-49	2x150	M12
280 ML	2-4	210	C	-	2xM63x1.5	2xM63x1.5	-	2xØ32-49	2x150	M12
280 ML	6	370	D	-	2xM63x1.5	2xM63x1.5	-	2xØ32-49	2x150	M12
280 MLB	8	370	D	-	2xM63x1.5	2xM63x1.5	-	2xØ32-49	2x150	M12
315 SM, ML	2-8	370	D	-	2xM63x1.5	2xM63x1.5	-	2xØ32-49	2x240	M12
315 LKA, LKB	2-4	370	D	-	2xM63x1.5	2xM63x1.5	-	2xØ32-49	2x240	M12
315 LKC	2-4	750	E	E-D (294)	-	-	Medium (278)	2xØ48-60	4x240	M12
315 LKA - LKC	6-8	370	D	-	2xM63x1.5	2xM63x1.5	-	2xØ32-49	2x240	M12
355 SMA - SMC	2-4	750	E	E-D (294)	-	-	Medium (278)	2xØ48-60	4x240	M12
355 SMC	6	750	E	E-D (294)	-	-	Medium (278)	2xØ48-60	4x240	M12
355 SMC	8	370	D	-	2xM63x1.5	2xM63x1.5	-	2xØ32-49	2x240	M12
355 SMA, SMB	6-8	370	D	-	2xM63x1.5	2xM63x1.5	-	2xØ32-49	2x240	M12
355 ML, LK	2-4	750	E	E-D (294)	-	-	Large (279)	2xØ60-80	4x240	M12
355 ML, LK	6-8	750	E	E-D (294)	-	-	Medium (278)	2xØ48-60	4x240	M12
400 L, LK	2-6	750	E	E-D (294)	-	-	Large (279)	2xØ60-80	4x240	M12
400 L, LK	8	750	E	E-D (294)	-	-	Medium (278)	2xØ48-60	4x240	M12
450	2-4	1200	E	E-2D (295)	-	-	2 x large (279)	4xØ60-80	6x240	M12
450 LA, LD	6	750	E	E-D (294)	-	-	Large (279)	2xØ60-80	4x240	M12
450 LB, LC	6	1200	E	E-D (294)	-	-	Medium (278)	2xØ48-60	4x240	M12
450 LA - LD	8	750	E	E-D (294)	-	-	Large (279)	2xØ60-80	4x240	M12

Auxiliary cable entries

160 - 180	2-8				1xM16			Ø5-9		
200 - 250	2-8				1xM16			Ø5-9		
280 - 450	2-8				2xM20			Ø8-14		

Motor size	Earthing on frame	Earthing in main terminal box
71 - 112	M4	M4
132	M5	M5
160 - 180	clamp	M6
200 - 250	clamp	M6
280 - 315	M10	2xM10
355 - 400	M10	2xM10
450	M10	4xM12

Terminal boxes and boards

The pictures below show standard terminal boxes and the corresponding terminal boards for various motor sizes.

Motor sizes 71 - 132



Fig. 1. Integrated terminal box for motor sizes 71 - 132. Tapped holes for cable entries.

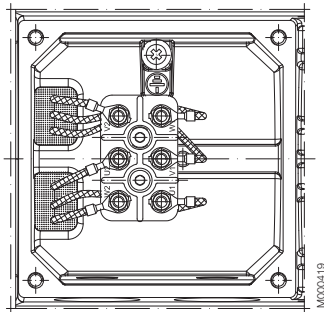

Fig. 2. Terminal board for motor sizes 71 - 080

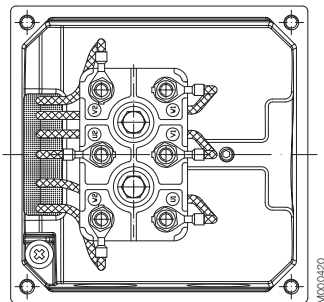

Fig. 3. Terminal board for motor sizes 90 - 112

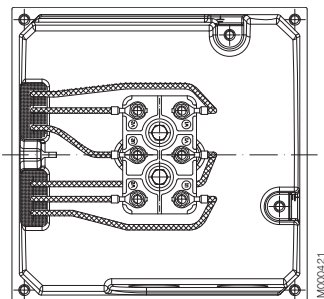

Fig. 4. Terminal board for motor sizes 132

Motor sizes 160 - 250

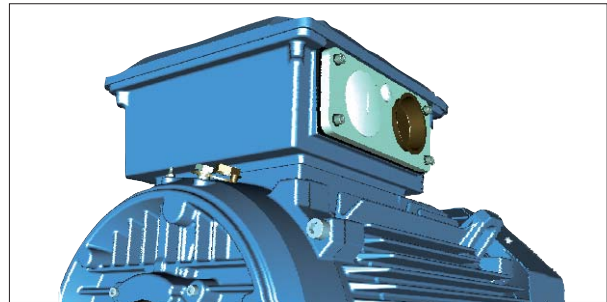

Fig. 5. Terminal box for motor sizes 160 - 250. Connection flanges with tapped cable entries.

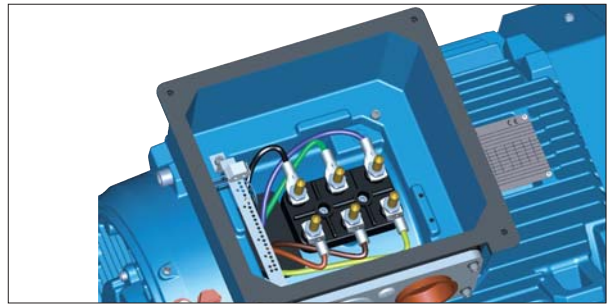
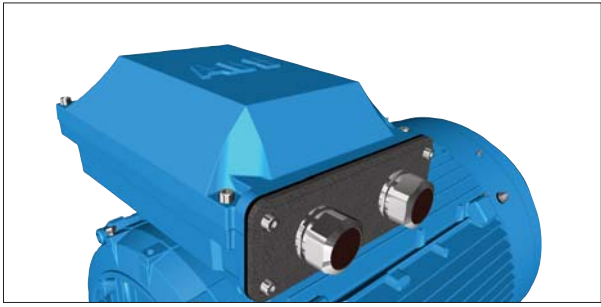

Fig. 6. Terminal board for motor sizes 160 - 250.

Motor sizes 280 - 315



M000423

Fig. 7. Terminal box for motor sizes 280 - 315, except LKC. Connection flange with tapped cable entries.

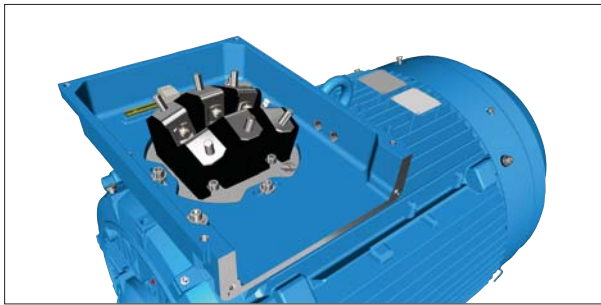

M000427

Fig. 8. Terminal board for motor sizes 280 - 315, except LKC.

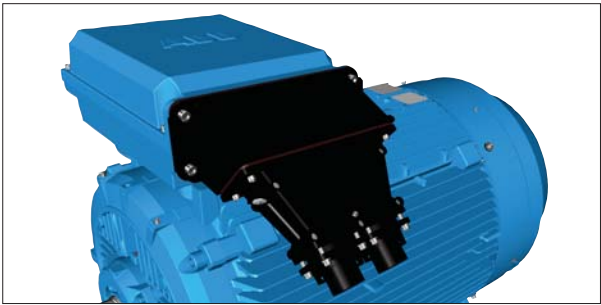

M000424

Fig. 9. Terminal box for motor sizes 315 LKC and 355 - 400. Adapter and cable sealing end unit.

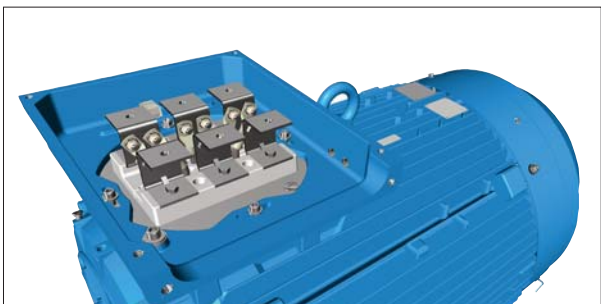

M000428

Fig. 10. Terminal board for motor sizes 315 LKC and 355 - 400.

Motor size 450

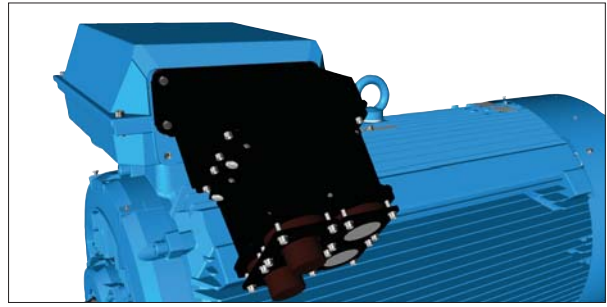

M000425

Fig. 11. Terminal box for motor sizes 450, with adapter and cable sealing end unit.

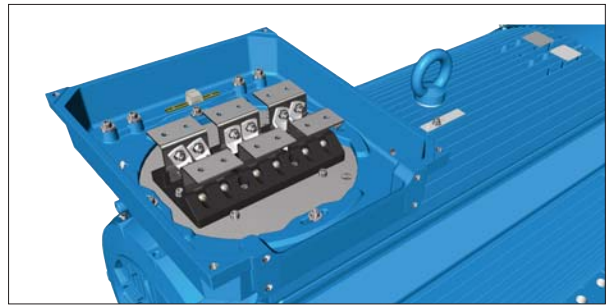

M000429

Fig. 12. Terminal board for motor size 450.

Terminal box

Terminal box alternatives

Optional adapters

There is a broad selection of cable termination accessories available to allow termination of one or several cables. The most common ones are explained below.

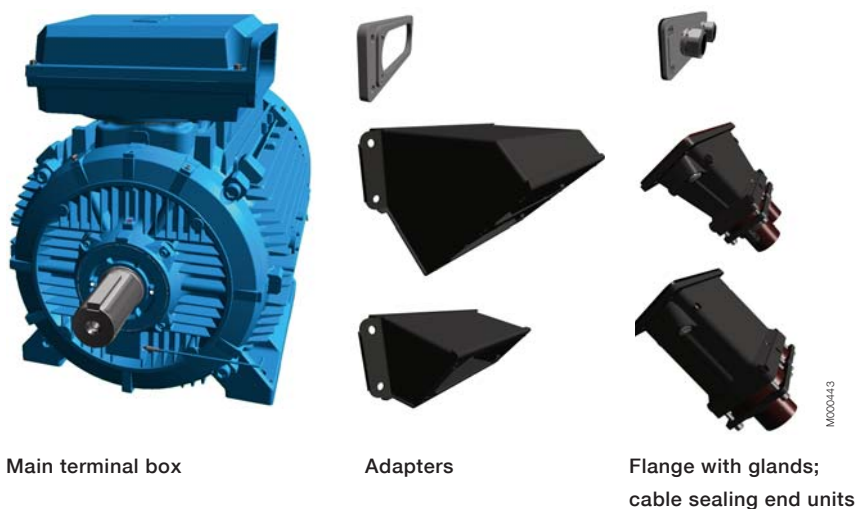

Main terminal box

Adapters

Flange with glands;
cable sealing end units

How to order?

- Check first that the terminal box itself allows mounting of the desired cable and cores (refer to motor type and terminal box type cross reference on previous page).
- If very large cables are used it might be necessary to use a larger terminal box than standard. Select the right cable gland(s) or cable sealing end unit(s) that match outer diameter of the cable(s)
- Select appropriate adapter or flange
- Note that turning the terminal box to a non-standard position might limit the use of some adapters.

Ordering example

Motor	200 kW, 4 pole, 400 V 50 Hz
Cables	2 pieces, outer diameter 58 mm, single core cross section 185 mm ² , clamping device needed, cables coming from below
Needed one terminal box for anticondensation heaters and another for temperature detectors, material must be cast iron.	
Motor	M3BP 315 MLA 4-pole, B3
Adapter	D-D - variant code 293
Cable sealing end unit	Variant code 278
Clamping	Variant code 231
Auxiliaries	Variant codes 380, 567, 568

Main terminal box and maximum single core cross-section

You can select one size larger than standard terminal box if a larger single cross-section is needed. The standard sizes of the main terminal box are listed in the following table. The terminal box is named according to its current-carrying capacity, from 120 to 1200. Check also the capacity of the cable entry to make sure that the cables fit. A larger terminal box can be ordered with variant code 019.

Standard terminal box	Size of opening	Max single cross-section mm ² /phase
120	B	1 × 70
210	C	2 × 240
370	D	2 × 300
750	E	4 × 500
1200	E	4 × 500

Optional adapters

To allow easy termination of cables entering the terminal box from above or below, an angle adapter is recommended.

These are available for motor sizes 280 and above and can also be used to allow the mounting of several cable sealing end units or gland plates. For exact suitability on a certain motor size, refer to the 'terminal box opening' column in section Standard terminal box.



Adapter	292	293	294	295	296	444
Variant code	292	293	294	295	296	444
Suited for motor sizes	280	315, 355	315 LKC, 355 - 450	315 LKC, 355 - 450	315 LKC, 355 - 450	315 LKC, 355 - 450
Opening to terminal box	C	D	E	E	E	E
Flange or opening for end unit	C	D	D	2 × D	3 × D	2 × E
Material	Steel	Steel	Steel	Steel	Steel	Steel
Notes			Included in type 750 terminal box when 750 is the standard size.	Included in type 1200 terminal box when 1200 is the standard size.	Only possible on type 1200 terminal box	Only possible on type 1200 terminal box

Cable sealing end units

As an alternative to flanges and cable glands, cable sealing end units can be used. These allow more space for spreading the cores for easy termination.

Cable sealing end units have rubber-sealed entries for one of two main cables. In addition, there are two plugged M20 holes for auxiliary cables.



End unit	277	278	279
Variant code	277	278	279
Suited for motor sizes	280	315, 355	315, 355
Opening to terminal box	C	D	D
Cable outer diameter	1 - 2 cables, 48 - 60 mm	1 - 2 cables, 48 - 60 mm	1 - 2 cables, 60 - 80 mm
Cable entry for auxiliary cable	2 × M20 plugged holes	2 × M20 plugged holes	2 × M20 plugged holes
Additional optional variants	EMC cable gland (704); Standard gland with clamping device (231)	EMC cable gland (704); Standard gland with clamping device (231)	EMC cable gland (704); Standard gland with clamping device (231)

Auxiliary terminal box

It's possible to equip motors with one or several auxiliary terminal boxes for connection of auxiliaries like heaters or temperature detectors. The standard auxiliary terminal box is made of aluminum and equipped with M20 glands for entry of the connection cables. As an option cast iron box is also available.

Connection terminals are spring loaded type for quick and easy connection. These are suitable for up to 2,5 mm² wires. Auxiliary terminal boxes are equipped with an earthing terminal. The first auxiliary terminal box is as standard located a RHS at D-end.

Related variant codes

380	Separate terminal box for temperature detectors, standard material
418	Separate terminal box for auxiliaries, standard material
567	Separate terminal box material: cast iron
568	Separate terminal box for heating elements, standard material
569	Separate terminal box for brake



Small, aluminum auxiliary terminal box (80 x 125 mm, max 12 strips). Earthing size M4

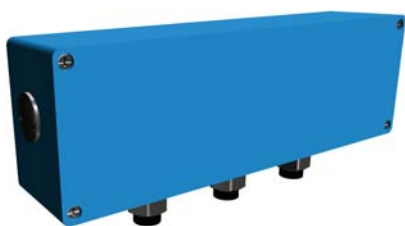

Large, aluminum auxiliary terminal box (80 x 250 mm, max 30 strips) Earthing M4



Cast iron auxiliary terminal box (211 x 188 mm, max 30 strips) Earthing M6

The standard cable entry size is M20 and the number of entries depends on the terminal box type and number of selected auxiliaries.

Terminal box

Dimensions

Terminal boxes, standard design with 6 terminal

For motor sizes 71 to 132 the terminal box is integrated in the frame and the dimensions for the terminal box are in the motor dimensions drawings.

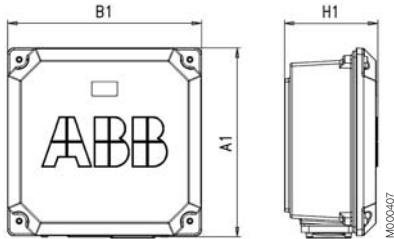

Motor sizes 160 - 250

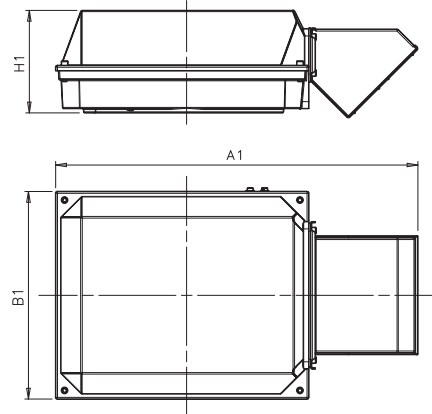

Motor size 450, top-mounted, terminal box 1200 + adapter

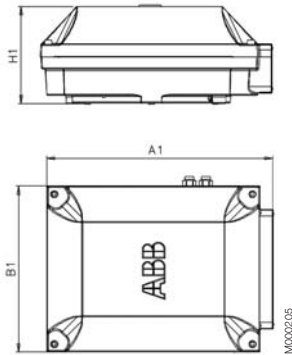

Motor sizes 280 - 315, 355 SMA, SMB, side-mounted, terminal boxes 210, 370

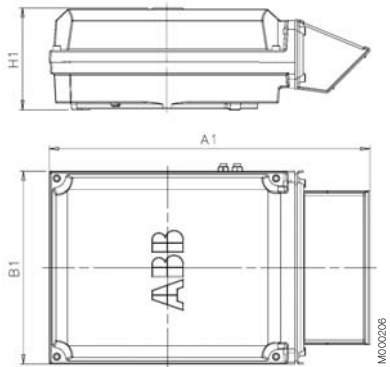

Motor sizes 2 - 4 pole 315 LKC, 355 - 450, top-mounted, terminal box 750 + adapter

Terminal box types acc. to current capacity	A1	B1	H1
Box types for 160 - 250			
160	257	257	145
260	257	257	136
350	300	311	150
Box types for 280 - 450			
210	416	306	177
370	451	347	200
750, top-mounted	686	413	219
750, side-mounted	525	413	219
1200 (variant code 295)*	1000	578	285
1200 (variant code 444)	1195	578	285
1200 (variant code 296)	1250	578	285

* Standard terminal box for motor size 450. See Optional adapters for more information.

Dimensions for terminal box inlets

Corresponds to motor sizes 160 and above

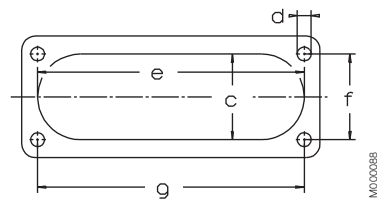

Inlet	c mm	e mm	f mm	g mm	d thread type
B	71	194	62	193	M8
C	62	193	62	193	M8
D	100	300	80	292	M10
E	115	370	100	360	M12

Dimension drawings

Flange-mounted cast iron motors, 71 - 132

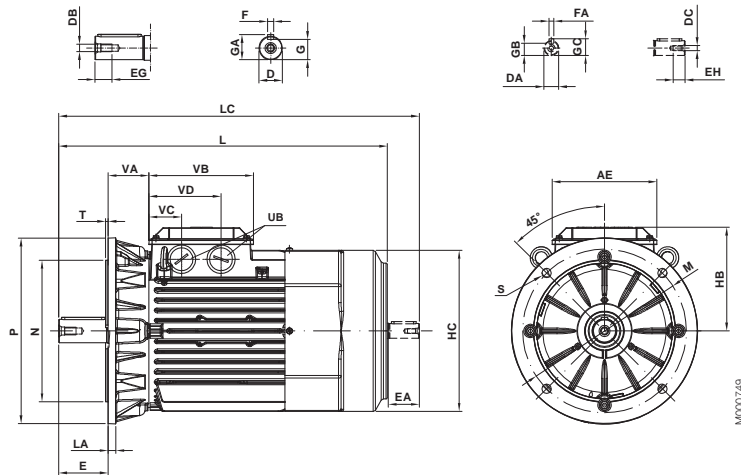

Mounting options IM B5 (IM 3001), IM 3002, large flange

IM B5 (IM3001), IM 3002

Motor size	AC	AE	D-Tol.	DA	DB	DC	E	EA	EG	EH	F	FA	G	GA	GB	GC	H	HA
71	139	97	14-j6	11	M5	M4	30	23	12.5	10	5	4	11	16	8.5	12.5	71	9
80	157	97	19-j6	14	M6	M5	40	30	16	12.5	6	5	15.5	21.5	11	16	80	10
90	177	110	24-j6	14	M8	M5	50	30	19	12.5	8	5	20	27	11	16	90	11
100	197	110	28-j6	19	M10	M6	60	40	22	16	8	6	24	31	15.5	21.5	100	12
112	197	110	28-j6	19	M10	M6	60	40	22	16	8	6	24	31	15.5	21.5	112	12
132	268.5	160	38-k6	24	M12	M8	80	50	28	19	10	8	33	41	20	27	132	14

Motor size	HB	HC	HD	HE	K	L	LA	LC	M	N	P	S	T	UB	VA	VB	VC	VD
71	108	139	178	62	7	264	9	292	130	110	160	10	3.5	M16x1.5	30	105	31.5	73.5
80	116	157	195	69	10	321	10	356	165	130	200	12	3.5	M25x1.5	32	105	32	74
90	130	177	219	79	10	357	10	392	165	130	200	12	3.5	M25x1.5	42	118	39	81
100	148	197	247	94	12	381	11	426	215	180	250	15	4.0	M32x1.5	45	118	36	84
112	148	197	259	94	12	403	11	448	215	180	250	15	4.0	M32x1.5	45	118	36	84
132	168	261	300	116	12	533	12.5	588	265	230	300	15	4.0	M32x1.5	65	169	82	130

Tolerances

A, B	± 0.8
D, DA	ISO j6
F, FA	ISO h9
H	+0 -0.5
N	ISO j6
C, CA	± 0.8

Dimension drawings

Flange-mounted cast iron motors, 71 - 132

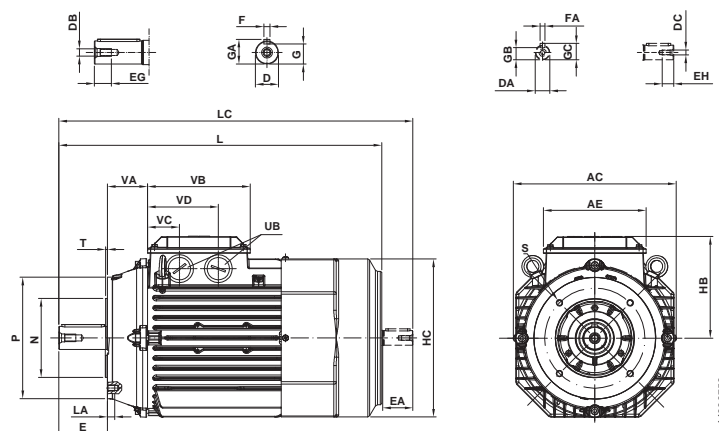

Mounting options IM B14 (IM 3601), IM 3602, small flange

IM B14 (IM 3601), IM 3602

Motor size	AC	AE	D-Tol.	DA	DB	DC	E	EA	EG	EH	F	FA	G	GA	GB	GC	H	HA
71	139	97	14-j6	11	M5	M4	30	23	12.5	10	5	4	11	16	8.5	12.5	71	9
80	157	97	19-j6	14	M6	M5	40	30	16	12.5	6	5	15.5	21.5	11	16	80	10
90	177	110	24-j6	14	M8	M5	50	30	19	12.5	8	5	20	27	11	16	90	11
100	197	110	28-j6	19	M10	M6	60	40	22	16	8	6	24	31	15.5	21.5	100	12
112	197	110	28-j6	19	M10	M6	60	40	22	16	8	6	24	31	15.5	21.5	112	12
132	268.5	160	38-k6	24	M12	M8	80	50	28	19	10	8	33	41	20	27	132	14

Motor size	HB	HC	HD	HE	K	L	LA	LC	M	N	P	S	T	UB	VA	VB	VC	VD
71	108	139	178	62	7	264	8	292	85	70	105	M6	2.5	M16×1.5	30	105	31.5	73.5
80	116	157	195	69	10	321	8	356	100	80	120	M6	3	M25×1.5	32	105	32	74
90	130	177	219	79	10	357	10	392	115	95	140	M8	3	M25×1.5	42	118	39	81
100	148	197	247	94	12	381	10	426	130	110	160	M8	3.5	M32×1.5	45	118	36	84
112	148	197	259	94	12	403	10	448	130	110	160	M8	3.5	M32×1.5	45	118	36	84
132	168	261	300	116	12	533	12.5	588	165	130	200	M10	3.5	M32×1.5	65	169	82	130

Tolerances

A, B	± 0.8
D, DA	ISO j6
F, FA	ISO h9
H	+0 -0.5
N	ISO j6
C, CA	± 0.8

Dimension drawings

Foot- and flange-mounted cast iron motors, 71 - 132

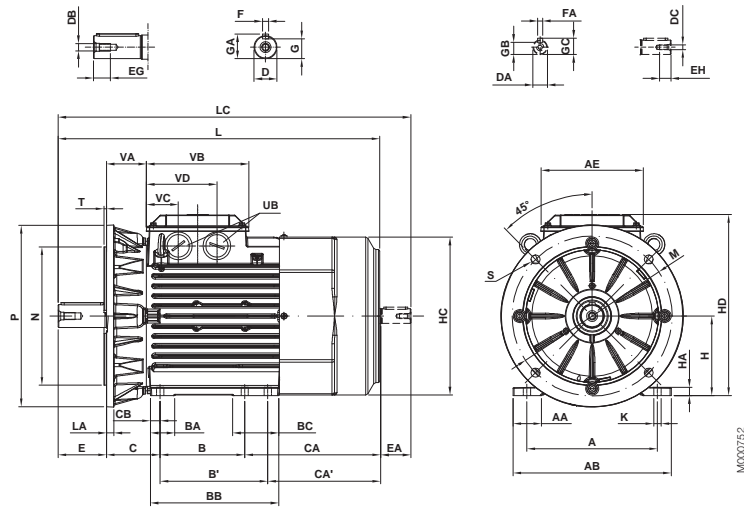

Mounting options IM B35 (IM 2001), IM 2002, large flange

IM B35 (IM 2001), IM 2102

Motor size	A	AA	AB	AC	AE	B	B'	BA	BB	BC	C	CA	CA'	CB	D-Tol.	DA	DB	DC
71	112	24	136	139	97	90	-	24	110	24	45	104	-	10	14-j6	11	M5	M4
80	125	28	154	157	97	100	-	28	125	28	50	136	-	12	19-j6	14	M6	M5
90	140	30	170	177	110	100	125	30	150	55	56	156	131	12	24-j6	14	M8	M5
100	160	38	200	197	110	140	-	34	172	34	63	123	-	16	28-j6	19	M10	M6
112	190	41	230	197	110	140	-	34	172	34	70	138	-	16	28-j6	19	M10	M6
132	216	47	262	268.5	160	140	178	40	212	76	89	228	190	16	38-k6	24	M12	M8

Motor size	E	EA	EG	EH	F	FA	G	GA	GB	GC	H	HA	HC	HD	HE	K	L	LA	LC
71	30	23	12.5	10	5	4	11	16	8.5	12.5	71	9	139	178	62	7	264	9	292
80	40	30	16	12.5	6	5	15.5	21.5	11	16	80	10	157	195	69	10	321	10	356
90	50	30	19	12.5	8	5	20	27	11	16	90	11	177	219	79	10	357	10	392
100	60	40	22	16	8	6	24	31	15.5	21.5	100	12	197	247	94	12	381	11	426
112	60	40	22	16	8	6	24	31	15.5	21.5	112	12	197	259	94	12	403	11	448
132	80	50	28	19	10	8	33	41	20	27	132	14	261	300	116	12	533	12.5	588

Motor size	M	N	P	S	T	UB	VA	VB	VC	VD
71	130	110	160	10	3.5	M16×1.5	30	105	31.5	73.5
80	165	130	200	12	3.5	M25×1.5	32	105	32	74
90	165	130	200	12	3.5	M25×1.5	42	118	39	81
100	215	180	250	15	4.0	M32×1.5	45	118	36	84
112	215	180	250	15	4.0	M32×1.5	45	118	36	84
132	265	230	300	15	4.0	M32×1.5	65	169	82	130

Tolerances

A, B	± 0.8
D, DA	ISO j6
F, FA	ISO h9
H	+0 -0.5
N	ISO j6
C, CA	± 0.8

Dimension drawings

Foot- and flange-mounted cast iron motors, 71 - 132

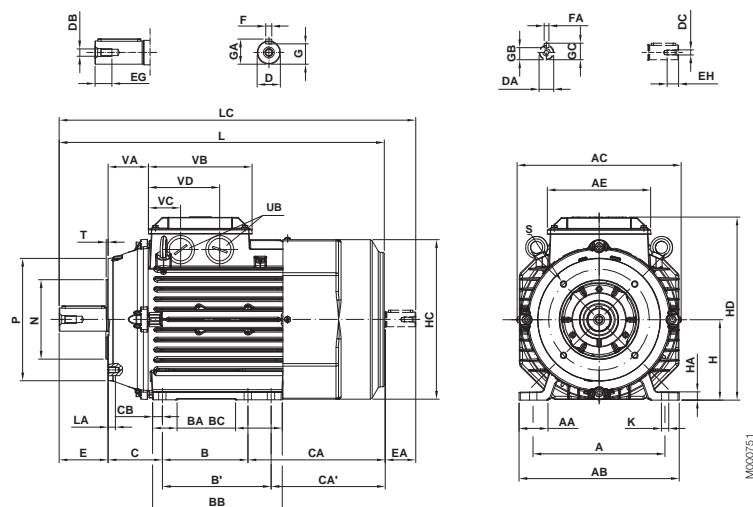

Mounting options IM B34 (IM 2101), IM 2102, small flange

IM B34 (IM 2101), IM 2102

Motor size	A	AA	AB	AC	AE	B	B'	BA	BB	BC	C	CA	CA'	CB	D-Tol.	DA	DB	DC
71	112	24	136	139	97	90	-	24	110	24	45	104	-	10	14-j6	11	M5	M4
80	125	28	154	157	97	100	-	28	125	28	50	136	-	12	19-j6	14	M6	M5
90	140	30	170	177	110	100	125	30	150	55	56	156	131	12	24-j6	14	M8	M5
100	160	38	200	197	110	140	-	34	172	34	63	123	-	16	28-j6	19	M10	M6
112	190	41	230	197	110	140	-	34	172	34	70	138	-	16	28-j6	19	M10	M6
132	216	47	262	268.5	160	140	178	40	212	76	89	228	190	16	38-k6	24	M12	M8

Motor size	E	EA	EG	EH	F	FA	G	GA	GB	GC	H	HA	HC	HD	HE	K	L	LA
71	30	23	12.5	10	5	4	11	16	8.5	12.5	71	9	139	178	62	7	264	8
80	40	30	16	12.5	6	5	15.5	21.5	11	16	80	10	157	195	69	10	321	8
90	50	30	19	12.5	8	5	20	27	11	16	90	11	177	219	79	10	357	10
100	60	40	22	16	8	6	24	31	15.5	21.5	100	12	197	247	94	12	381	10
112	60	40	22	16	8	6	24	31	15.5	21.5	112	12	197	259	94	12	403	10
132	80	50	28	19	10	8	33	41	20	27	132	14	261	300	116	12	533	12

Motor size	LC	M	N	P	S	T	UB	VA	VB	VC	VD
71	292	85	70	105	M6	2.5	M16×1.5	30	105	31.5	73.5
80	356	100	80	120	M6	3	M25×1.5	32	105	32	74
90	392	115	95	140	M8	3	M25×1.5	42	118	39	81
100	426	130	110	160	M8	3.5	M32×1.5	45	118	36	84
112	448	130	110	160	M8	3.5	M32×1.5	45	118	36	84
132	588	165	130	200	M10	3.5	M32×1.5	65	169	82	130

Tolerances

A, B	± 0.8
D, DA	ISO j6
F, FA	ISO h9
H	+0 -0.5
N	ISO j6
C, CA	± 0.8

Dimension drawings

Foot-mounted cast iron motors, 160 - 250

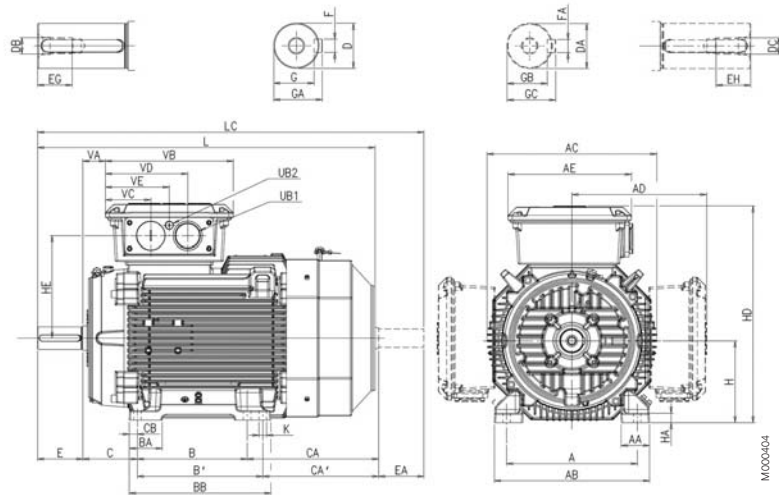

Mounting options: IM B3 (IM 1001), IM B6 (IM 1051), IM B7 (IM 1061), IM B8 (IM 1071), IM V5 (IM 1011), IM V6 (IM 1031)

IM B3 (IM 1001), IM1002

Motor size	Poles	A	AA	AB	AC	AD	AE	B	B'	BA	BB	C	CA	CA'	CB	D	DA	DB	DC
160 ¹⁾	2 - 8	254	67	310	338	261	257	210	254	69	294	108	164	126	20	42	32	M16	M12
160 ²⁾	2 - 8	254	67	310	338	261	257	210	254	69	294	108	262	224	20	42	32	M16	M12
180	2 - 8	279	67	340	381	281	257	241	279	68	317	121	263	225	19	48	32	M16	M12
200	2 - 8	318	69	378	413	328	300	267	305	80	345	133	314	276	20	55	45	M20	M16
225	2	356	84	435	460	348	300	286	311	69	351	149	314	289	20	55	55	M20	M20
225	2 - 8	356	84	435	460	348	300	286	311	69	351	149	314	289	20	60	55	M20	M20
250	2	406	92	480	508	376	300	311	349	69	392	168	281	243	23	60	55	M20	M20
250	2 - 8	406	92	480	508	376	300	311	349	69	392	168	281	243	23	65	55	M20	M20

Motor size	Poles	E	EA	EG	EH	F	FA	G	GA	GB	GC	H	HA	HD	HE	K	L	LC	UB1
160 ¹⁾	2 - 8	110	80	36	28	12	10	37	45	27	35	160	23	421	195	14.5	584	671.5	M40
160 ²⁾	2 - 8	110	80	36	28	12	10	37	45	27	35	160	23	421	195	14.5	681	768.5	M40
180	2 - 8	110	80	36	28	14	10	42.5	51.5	27	35	180	23	461	215	14.5	726	815	M40
200	2 - 8	110	110	42	36	16	14	49	59	39.5	48.5	200	23	528	249	18.5	821	934	M63
225	2	110	110	42	42	16	16	49	59	49	59	225	23	573	269	18.5	849	971	M63
225	4 - 8	140	110	42	42	18	16	53	64	49	59	225	23	573	269	18.5	879	1001	M63
250	2	140	110	42	42	18	16	53	64	49	59	250	23	626	297	24.0	884	1010	M63
250	4 - 8	140	110	42	42	18	16	58	69	49	59	250	23	626	297	24.0	884	1010	M63

Motor size	Poles	UB2	VA	VB	VC	VD	VE
160 ¹⁾	2 - 8	M16	49	257	95	162	129
160 ²⁾	2 - 8	M16	49	257	95	162	129
180	2 - 8	M16	62	257	95	162	129
200	2 - 8	M16	55	311	111	201	156
225	2	M16	48	311	111	201	156
225	4 - 8	M16	48	311	111	201	156
250	2	M16	48	311	111	201	156
250	4 - 8	M16	48	311	111	201	156

Tolerances	
A, B	ISO js14
C, CA	± 0.8
D, DA	ISO k6 < Ø 50mm ISO m6 > Ø 50mm
F, FA	ISO h9
H	+0 -0.5

M3BP IE2:

- ¹⁾ MLA, MLB 2 and 8, MLC 2
- ²⁾ MLB 4-6, MLC 4-8, MLD, MLE

M3BP IE3:

- ¹⁾ MLA 2 only
- ²⁾ All others

Dimension drawings

Flange-mounted cast iron motors, 160 - 250

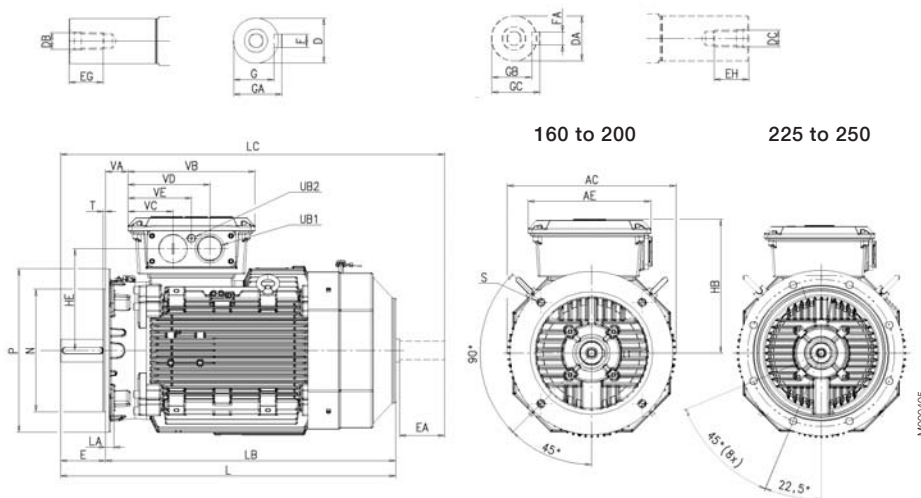

Mounting options: IM B5 (IM 3001), V1 (IM 3011), V3 (IM 3031)

IM B5 (IM 3001), IM3002

Motor size	Poles	AC	AE	D	DA	DB	DC	E	EA	EG	EH	F	FA	G	GA	GB	GC	HB
160 ¹⁾	2 - 8	338	257	42	32	M16	M12	110	80	36	28	12	10	37	45	27	35	261
160 ²⁾	2 - 8	338	257	42	32	M16	M12	110	80	36	28	12	10	37	45	27	35	261
180	2 - 8	381	257	48	32	M16	M12	110	80	36	28	14	10	42.5	51.5	27	35	281
200	2 - 8	413	300	55	45	M20	M16	110	110	42	36	16	14	49	59	39.5	48.5	328
225	2	460	300	55	55	M20	M20	110	110	42	42	16	16	49	59	49	59	348
225	4 - 8	460	300	60	55	M20	M20	140	110	42	42	18	16	53	64	49	59	325
250	2	508	300	60	55	M20	M20	140	110	42	42	18	16	53	64	49	59	376
250	4 - 8	508	300	65	55	M20	M20	140	110	42	42	18	16	58	69	49	59	376

Motor size	Poles	HE	L	LA	LB	LC	M	N	P	S	T	UB1	UB2	VA	VB	VC	VD	VE
160 ¹⁾	2 - 8	195	584	20	474	671.5	300	250	350	19	5	M40	M16	49	257	95	162	129
160 ²⁾	2 - 8	195	681	20	571	768.5	300	250	350	19	5	M40	M16	49	257	95	162	129
180	2 - 8	215	726	15	616	815	300	250	350	19	5	M40	M16	62	257	95	162	129
200	2 - 8	249	821	20	711	934	350	300	400	19	5	M63	M16	55	311	111	201	156
225	2	269	849	20	739	971	400	350	450	19	5	M63	M16	48	311	111	201	156
225	4 - 8	269	879	20	739	1001	400	350	450	19	5	M63	M16	48	311	111	201	156
250	2	297	884	24	744	1010	500	450	550	19	5	M63	M16	48	311	111	201	156
250	4 - 8	297	884	24	744	1010	500	450	550	19	5	M63	M16	48	311	111	201	156

Tolerances

D, DA	ISO k6 < Ø 50mm
	ISO m6 > Ø 50mm
F, FA	ISO h9
N	ISO j6

M3BP IE2:

- ¹⁾ MLA, MLB 2 and 8, MLC 2
- ²⁾ MLB 4-6, MLC 4-8, MLD, MLE

M3BP IE3:

- ¹⁾ MLA 2 only
- ²⁾ All others

Dimension drawings

Foot- and flange-mounted cast iron motors, 160 - 250

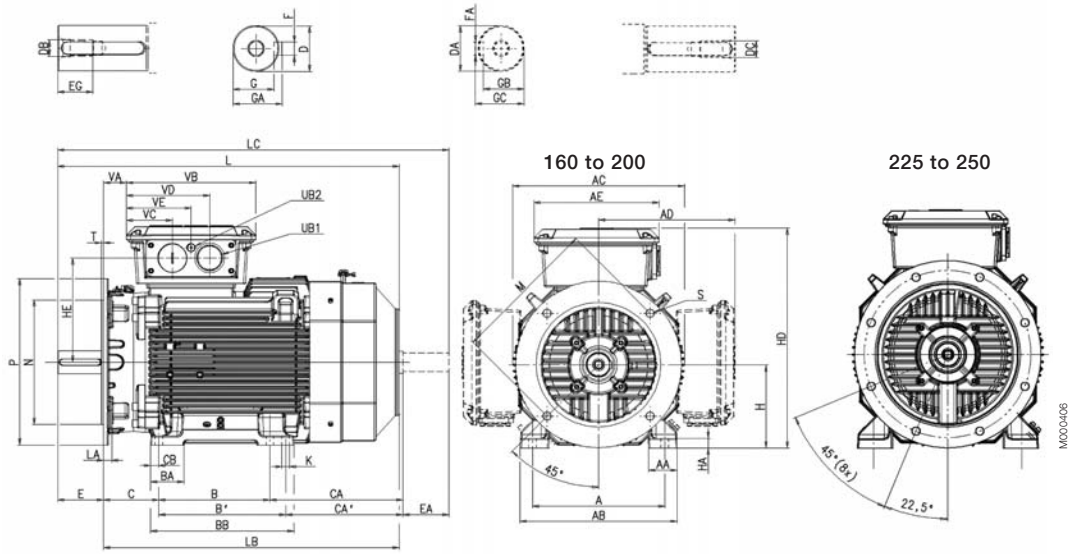

Mounting options: IM B35 (IM 2001), IM V15 (IM 2011), IM V36 (IM 2031)

IM B35 (IM 2001), IM2102

Motor size	Poles	A	AA	AB	AC	AD	AE	B	B'	BA	BB	C	CA	CA'	CB	D	DA	DB	DC	E	EA	EG	EH
160 ¹⁾	2 - 8	254	67	310	338	261	257	210	254	69	294	108	164	126	20	42	32	M16	M12	110	80	36	28
160 ²⁾	2 - 8	254	67	310	338	261	257	210	254	69	294	108	262	224	20	42	32	M16	M12	110	80	36	28
180	2 - 8	279	67	340	381	281	257	241	279	68	317	121	263	225	19	48	32	M16	M12	110	80	36	28
200	2 - 8	318	69	378	413	328	300	267	305	80	345	133	314	276	20	55	45	M20	M16	110	110	42	36
225	2	356	84	435	460	348	300	286	311	69	351	149	314	289	20	55	55	M20	M20	110	110	42	42
225	4 - 8	356	84	435	460	348	300	286	311	69	351	149	314	289	20	60	55	M20	M20	140	110	42	42
250	2	406	92	480	508	376	300	311	349	69	392	168	281	243	23	60	55	M20	M20	140	110	42	42
250	4 - 8	406	92	480	508	376	300	311	349	69	392	168	281	243	23	65	55	M20	M20	140	110	42	42

Motor size	Poles	F	FA	G	GA	GB	GC	H	HA	HD	HE	K	L	LA	LB	LC	M	N	P	S	T	UB1	UB2
160 ¹⁾	2 - 8	12	10	37	45	27	35	160	23	421	195	14.5	584	20	474	671.5	300	250	350	19	5	M40	M16
160 ²⁾	2 - 8	12	10	37	45	27	35	160	23	421	195	14.5	681	20	571	768.5	300	250	350	19	5	M40	M16
180	2 - 8	14	10	42.5	51.5	27	35	180	23	461	215	14.5	726	15	616	815	300	250	350	19	5	M40	M16
200	2 - 8	16	14	49	59	39.5	48.5	200	23	528	249	18.5	821	20	711	934	350	300	400	19	5	M63	M16
225	2	16	16	49	59	49	59	225	23	573	269	18.5	849	20	739	971	400	350	450	19	5	M63	M16
225	4 - 8	18	16	53	64	49	59	225	23	573	269	18.5	879	20	739	1001	400	350	450	19	5	M63	M16
250	2	18	16	53	64	49	59	250	23	626	297	24.0	884	24	744	1010	500	450	550	19	5	M63	M16
250	4 - 8	18	16	58	69	49	59	250	23	626	297	24.0	884	24	744	1010	500	450	550	19	5	M63	M16

Motor size	Poles	VA	VB	VC	VD	VE
160 ¹⁾	2 - 8	49	257	95	162	129
160 ²⁾	2 - 8	49	257	95	162	129
180	2 - 8	62	257	95	162	129
200	2 - 8	55	311	111	201	156
225	2	48	311	111	201	156
225	4 - 8	48	311	111	201	156
250	2	48	311	111	201	156
250	4 - 8	48	311	111	201	156

Tolerances	
A, B	ISO js14
C, CA	± 0.8
D, DA	ISO k6 < Ø 50 mm ISO m6 > Ø 50 mm
F, FA	ISO h9
H	+0 -0.5
N	ISO j6

M3BP IE2:

- ¹⁾ MLA, MLB 2 and 8, MLC 2
- ²⁾ MLB 4-6, MLC 4-8, MLD, MLE

M3BP IE3:

- ¹⁾ MLA 2 only
- ²⁾ All others

Dimension drawings

Foot-mounted cast iron motors, 280 - 315

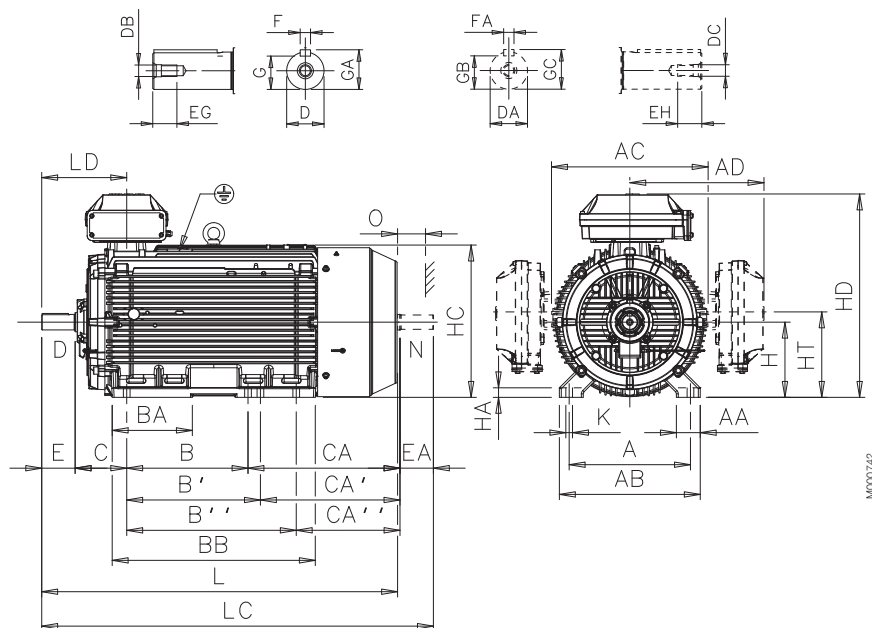

Mounting options: IM B3 (IM 1001), IM B6 (IM 1051), IM B7 (IM 1061), IM B8 (IM 1071), IM V5 (IM 1011), IM V6 (IM 1031)

Motor size	Poles	A	AA	AB	AC	AD ¹⁾	AD ²⁾	B	B'	B''	BA	BB	C	CA	CA'	CA''	D	DA	DB	DC	E	EA
280 SM ₋	2	457	84	530	577	481	-	368	419	-	147	506	190	400	349	-	65	60	M20	M20	140	140
	4 - 12	457	84	530	577	481	-	368	419	-	147	506	190	400	349	-	75	65	M20	M20	140	140
280 ML ₋	2	457	84	530	577	-	504	419	457	-	193	608	190	400	349	-	65	60	M20	M20	140	140
	4 - 12	457	84	530	577	481	504	419	457	-	193	608	190	400	349	-	75	65	M20	M20	140	140
315 SM ₋	2	508	100	590	654	545	-	406	457	-	180	558	216	420	369	-	65	60	M20	M20	140	140
	4 - 12	508	100	590	654	545	-	406	457	-	180	558	216	420	369	-	80	75	M20	M20	170	140
315 ML ₋	2	508	100	590	654	545	-	457	508	-	212	669	216	480	429	-	65	60	M20	M20	140	140
	4 - 12	508	100	590	654	545	-	457	508	-	212	669	216	480	429	-	90	75	M24	M20	170	140
315 LK ₋	2	508	100	590	654	562	576	508	560	710	336	851	216	635	583	433	65	60	M20	M20	140	140
	4 - 12	508	100	590	654	562	576	508	560	710	336	851	216	635	583	433	90	75	M24	M20	170	140

Motor size	Poles	EG	EH	F	FA	G	GA	GB	GC	H	HA	HC	HD ¹⁾ top-m.	HD ²⁾ top-m.	HT	K	L	LC	LD	LD	O
																			top-m.	side-m.	
280 SM ₋	2	40	40	18	18	58	69	53	64	280	31	564	762	-	337.5	24	1088	1238	336	539	100
	4 - 12	40	40	20	18	67.5	79.5	58	69	280	31	564	762	-	337.5	24	1088	1238	336	539	100
280 ML ₋	2	40+	40	18	18	58	69	53	64	280	31	564	-	785	337.5	24	1189	1340	336	590	100
	4 - 12	40	40	20	18	67.5	79.5	58	69	280	31	564	762	785	337.5	24	1189	1340	336	590	100
315 SM ₋	2	40	40	18	18	58	69	53	64	315	40	638	852	-	375	28	1174	1322	356	585	115
	4 - 12	40	40	22	20	71	85	67.5	79.5	315	40	638	852	-	375	28	1204	1352	386	615	115
315 ML ₋	2	40	40	18	18	58	69	53	64	315	40	638	852	-	375	28	1285	1433	356	640	115
	4 - 12	48	40	25	20	81	95	67.5	79.5	315	40	638	852	-	375	28	1315	1463	386	670	115
315 LK ₋	2	40	40	18	18	58	69	53	64	315	40	638	870	880	359	28	1491	1639	356	721	115
	4 - 12	48	40	25	20	81	95	67.5	79.5	315	40	638	852	880	359	28	1521	1669	386	751	115

Tolerances

A, B	± 0.8
C, CA	± 0.8
D	ISO k6 < Ø 50 mm ISO m6 > Ø 50 mm

Tolerances

F	ISO h9
H	+0 -0.5
N	ISO j6

¹⁾ Terminal box 370

²⁾ Terminal box 750

Dimension drawings

Flange-mounted cast iron motors, 280 - 315

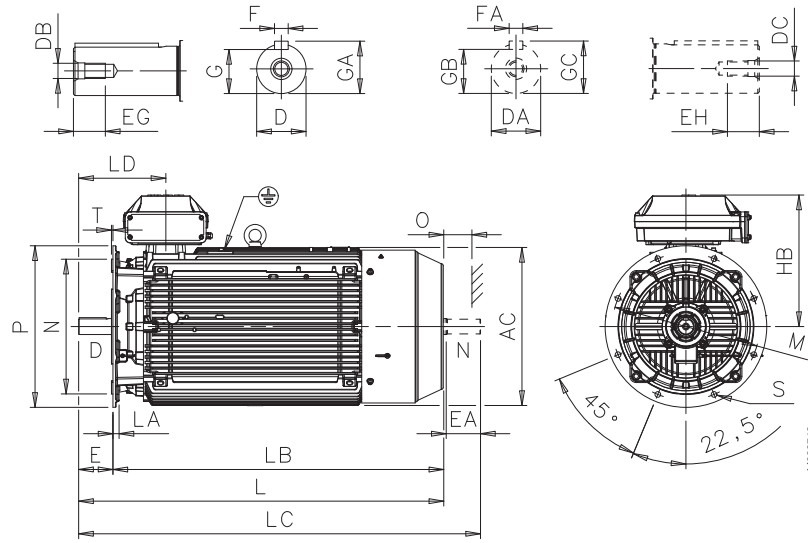

Mounting options: IM B5 (IM 3001), V1 (IM 3011), V3 (IM 3031)

Motor size	Poles	AC	D	DA	DB	DC	E	EA	EG	EH	F	FA	G	GA	GB
280 SM_	2	577	65	60	M20	M20	140	140	40	40	18	18	58	69	53
	4 - 12	577	75	65	M20	M20	140	140	40	40	20	18	67.5	79.5	58
280 ML_	2	577	65	60	M20	M20	140	140	40	40	18	18	58	69	53
	4 - 12	577	75	65	M20	M20	140	140	40	40	20	18	67.5	79.5	58
315 SM_	2	645	65	60	M20	M20	140	140	40	40	18	18	58	69	53
	4 - 12	645	80	75	M20	M20	170	140	40	40	22	20	71	85	67.5
315 ML_	2	645	65	60	M20	M20	140	140	40	40	18	18	58	69	53
	4 - 12	645	90	75	M24	M20	170	140	48	40	25	20	81	95	67.5
315 LK_	2	645	65	60	M20	M20	140	140	40	40	18	18	58	69	53
	4 - 12	645	90	75	M24	M20	170	140	48	40	25	20	81	95	67.5

Motor size	Poles	GC	HB ¹⁾	HB ²⁾	L	LA	LB	LC	LD	M	N	O	P	S	T
280 SM_	2	64	482	-	1088	23	948	1238	336	500	450	100	550	18	5
	4 - 12	69	482	-	1088	23	948	1238	336	500	450	100	550	18	5
280 ML_	2	64	-	505	1189	23	1049	1340	336	500	450	100	550	18	5
	4 - 12	69	482	505	1189	23	1049	1340	336	500	450	100	550	18	5
315 SM_	2	64	537	-	1174	25	1034	1322	356	600	550	115	660	23	6
	4 - 12	79.5	537	-	1204	25	1034	1352	386	600	550	115	660	23	6
315 ML_	2	64	537	-	1285	25	1145	1433	356	600	550	115	660	23	6
	4 - 12	79.5	537	-	1315	25	1145	1463	386	600	550	115	660	23	6
315 LK_	2	64	537	565	1491	25	1306	1639	356	600	550	115	660	23	6
	4 - 12	79.5	537	565	1521	25	1306	1669	386	600	550	115	660	23	6

Tolerances

D, DA ISO m6

F, FA ISO h9

N ISO j6 (280 SM_)

ISO js6 (315_)

¹⁾ Terminal box 370

²⁾ Terminal box 750

Dimension drawings

Foot- and flange-mounted cast iron motors, 280 - 315

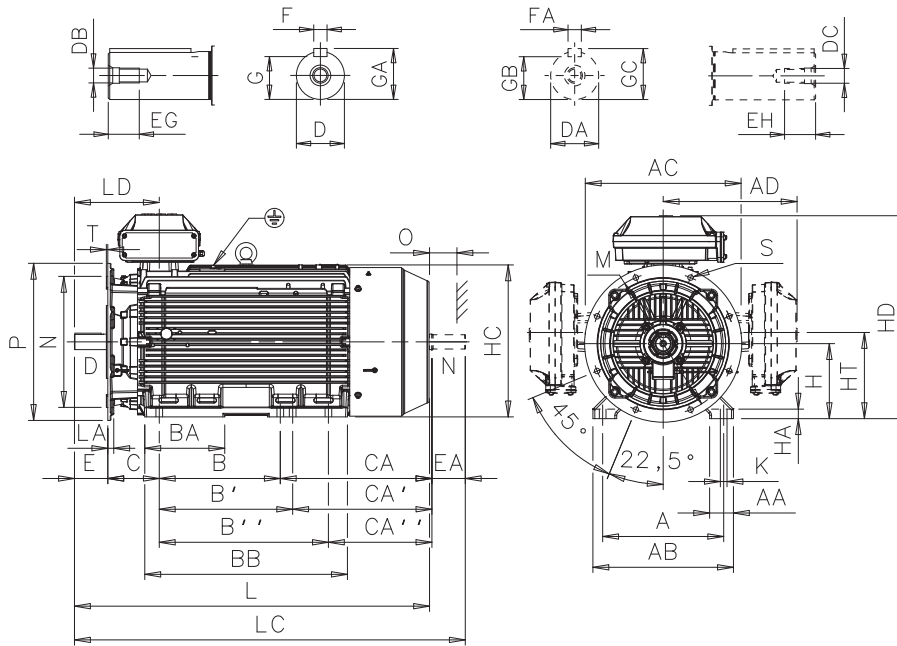

Mounting options: IM B35 (IM 2001), IM V15 (IM 2011), IM V36 (IM 2031)

Motor size	Poles	A	AA	AB	AC	AD ¹⁾	AD ²⁾	B	B'	B''	BA	BB	C	CA	CA'	CA''	D	DA	DB	DC	E	EA	EG	EH	F
280 SM_	2	457	84	530	577	481	-	368	419	-	147	506	190	400	349	-	65	60	M20	M20	140	140	40	40	18
	4 - 12	457	84	530	577	481	-	368	419	-	147	506	190	400	349	-	75	65	M20	M20	140	140	40	40	20
280 ML_	2	457	84	530	577	-	504	419	457	-	193	608	190	400	349	-	65	60	M20	M20	140	140	40	40	18
	4 - 12	457	84	530	577	481	504	419	457	-	193	608	190	400	349	-	75	65	M20	M20	140	140	40	40	20
315 SM_	2	508	100	590	654	545	-	406	457	-	180	558	216	420	369	-	65	60	M20	M20	140	140	40	40	18
	4 - 12	508	100	590	654	545	-	406	457	-	180	558	216	420	369	-	80	75	M20	M20	170	140	40	40	22
315 ML_	2	508	100	590	654	545	-	457	508	-	212	669	216	480	429	-	65	60	M20	M20	140	140	40	40	18
	4 - 12	508	100	590	654	545	-	457	508	-	212	669	216	480	429	-	90	75	M24	M20	170	140	48	40	25
315 LK_	2	508	100	590	654	562	576	508	560	710	336	851	216	635	583	433	65	60	M20	M20	140	140	40	40	18
	4 - 12	508	100	590	654	562	576	508	560	710	336	851	216	635	583	433	90	75	M24	M20	170	140	48	40	25

Motor size	Poles	FA	G	GA	GB	GC	H	HA	HC	HD ¹⁾ top-m.	HD ²⁾ top-m.	HT	K	L	LA	LC	LD top-m.	LD side-m.	M	N	O	P	S	T
280 SM_	2	18	58	69	53	64	280	31	564	762	-	337.5	24	1088	23	1238	336	539	500	450	100	550	18	5
	4 - 12	18	67.5	79.5	58	69	280	31	564	762	-	337.5	24	1088	23	1238	336	539	500	450	100	550	18	5
280 ML_	2	18	58	69	53	64	280	31	564	-	785	337.5	24	1189	23	1340	336	590	500	450	100	55	18	5
	4 - 12	18	67.5	79.5	58	69	280	31	564	762	785	337.5	24	1189	23	1340	336	590	500	450	100	550	15	5
315 SM_	2	18	58	69	53	64	315	40	638	852	-	375	28	1174	25	1322	356	585	600	550	115	660	23	6
	4 - 12	20	71	85	67.5	79.5	315	40	638	852	-	375	28	1204	25	1352	386	615	600	550	115	660	23	6
315 ML_	2	18	58	69	53	64	315	40	638	852	-	375	28	1285	25	1433	356	640	600	550	115	660	23	6
	4 - 12	20	81	95	67.5	79.5	315	40	638	852	-	375	28	1315	25	1463	386	670	600	550	115	660	23	6
315 LK_	2	18	58	69	53	64	315	40	638	852	880	359	28	1491	25	1639	356	721	600	550	115	660	23	6
	4 - 12	20	81	95	67.5	79.5	315	40	638	852	880	359	28	1521	25	1669	386	751	600	550	115	660	23	6

Tolerances

A, B	± 0.8
D	ISO m6
F	ISO h9
H	+0 -1.0N

Tolerances

N	ISO j6 (280 SM_)
	ISO js6 (315_)
C	± 0.8

¹⁾ Terminal box 370
²⁾ Terminal box 750

Dimension drawings

Foot-mounted cast iron motors, 355 - 450

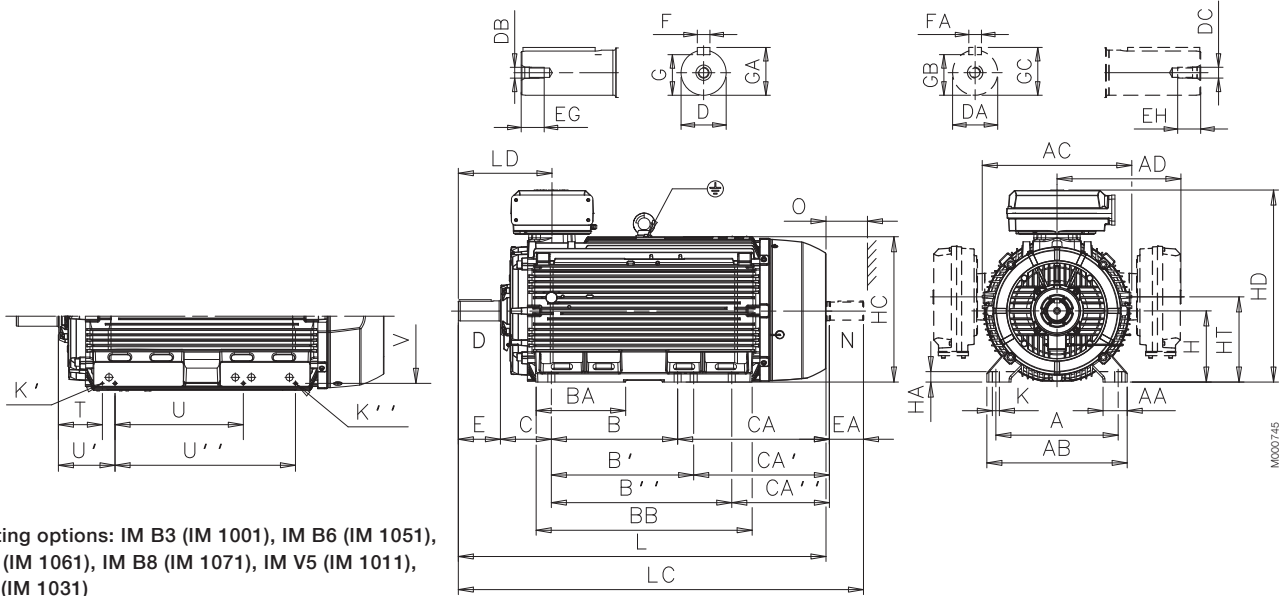

Mounting options: IM B3 (IM 1001), IM B6 (IM 1051), IM B7 (IM 1061), IM B8 (IM 1071), IM V5 (IM 1011), IM V6 (IM 1031)

Motor size	Poles	A	AA	AB	AC	AD ¹⁾	AD ²⁾	B	B'	B''	BA	BB	C	CA	CA'	CA''	D	DA	DB	DC	E	EA	EG	EH	F	FA
355 SM _L	2	610	120	700	746	604	618	500	560	-	221	722	254	525	465	-	70	70	M20	M20	140	140	42	40	20	20
	4 - 12	610	120	700	746	604	618	500	560	-	221	722	254	525	465	-	100	90	M24	M24	210	170	51	51	28	25
355 ML _L	2	610	120	700	746	604	618	560	630	-	267	827	254	500	570	-	70	70	M20	M20	140	140	42	40	20	20
	4 - 12	610	120	700	746	604	618	560	630	-	267	827	254	500	570	-	100	90	M24	M24	210	170	51	51	28	25
355 LK _L ⁴⁾	2	610	120	700	746	604	618	630	710	900	447	1077	254	750	670	480	70	70	M20	M20	140	140	42	40	20	20
	4 - 12	610	120	700	746	604	618	630	710	900	447	1077	254	750	670	480	100	90	M24	M24	210	170	51	51	28	25
400 L _L	2	710	150	840	834	-	660	900	1000	-	410	1156	224	567	467	-	80	70	M20	M20	170	140	42	40	22	20
	4 - 12	710	150	840	834	-	660	900	1000	-	410	1156	224	567	467	-	110	90	M24	M24	210	170	50	51	28	25
400 LK _L ⁴⁾	2	686	150	840	834	-	660	710	800	900	410	1156	280	701	611	511	80	70	M20	M20	170	140	42	40	22	20
	4 - 12	686	150	840	834	-	660	710	800	900	410	1156	280	701	611	511	100	90	M24	M24	210	170	50	51	28	25
450 L _L	2	800	160	950	966	-	-	1000	1120	1250	320	1300	250	-	-	-	80	-	M20	-	170	-	42	-	22	-
	4 - 12	800	160	950	966	-	-	1000	1120	1250	450	1420	250	737	617	487	120	100	M24	M24	210	210	50	50	32	28

Motor size	Poles	G	GA	GB	GC	H	HA	HC	HD ¹⁾	HD ²⁾	HD ³⁾	HD	K	K'	K''	L	LC	LD	LD	O	T	U	U'	U''	V
									top-m.	top-m.	top-m.	side-m.						top-m.	side-m.						
355 SM _L	2	62.5	74.5	62.5	74.5	355	45	725	944	958	-	843	35	10	M16	1409	1559	397	679	130	120	280	560	-	670
	4 - 12	90	106	81	95	355	45	725	944	958	-	843	35	10	M16	1479	1659	467	750	130	120	282	560	-	670
355 ML _L	2	62.5	74.5	62.5	74.5	355	45	725	944	958	-	843	35	10	M16	1514	1664	397	732	130	120	282	630	-	670
	4 - 12	90	106	81	95	355	45	725	944	958	-	843	35	10	M16	1584	1764	467	802	130	120	282	630	-	670
355 LK _L ⁴⁾	2	62.5	74.5	62.5	74.5	355	45	725	944	958	-	843	35	10	M16	1764	1914	397	857	130	120	282	630	890	670
	4 - 12	90	106	81	95	355	45	725	944	958	-	843	35	10	M16	1834	2014	467	927	130	120	282	630	890	670
400 L _L	2	71	85	67.5	79.5	400	45	814	-	1045	-	943	35	10	M16	1851	2001	458	909	150	248	287	887	-	802
	4 - 12	90	116	81	95	400	45	814	-	1045	-	943	35	10	M16	1891	2071	498	949	150	248	287	887	-	802
400 LK _L ⁴⁾	2	71	85	67.5	79.5	400	45	814	-	1045	-	943	35	10	M16	1851	2001	458	909	150	248	287	748	916	802
	4 - 12	90	106	81	95	400	45	814	-	1045	-	943	35	10	M16	1891	2071	498	949	150	248	287	748	916	802
450 L _L	2	71	85	-	-	450	46	933	-	1213	1281	-	40	10	M16	2027	-	450	-	180	274	290	861	-	912
	4 - 12	109	127	100	116	450	46	933	-	1169	1231	-	42	10	M16	2187	2407	525	-	180	274	323	841	-	912

Tolerances

A, B	± 0.8
D, DA	ISO m6
F, FA	ISO h9

Tolerances

H	+0 -1.0
N	ISO j6
C, CA	± 0.8

¹⁾ Terminal box 370

²⁾ Terminal box 750

³⁾ Terminal box 1200

⁴⁾ Size with alternative dimensions

Dimension drawings

Flange-mounted cast iron motors, 355 - 450

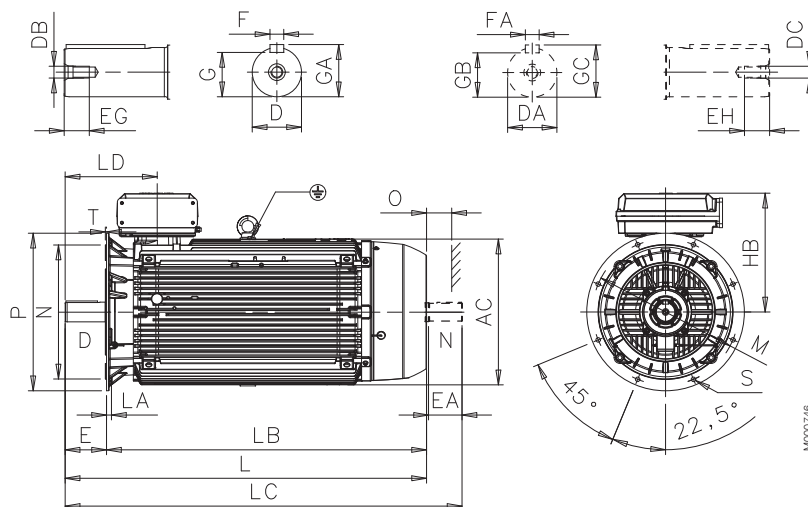

Mounting options: IM B5 (IM 3001), V1 (IM 3011), V3 (IM 3031), IM B14 (IM 3601), V18 (IM 3611), V19 (IM 3631)

Motor size	Poles	AC	D	DA	DB	DC	E	EA	EG	EH	F	FA	G	GA	GB	GC	GD	GF
355 SM ₋	2	740	70	70	M20	M20	140	140	42	40	20	20	62.5	74.5	62.5	74.5	12	12
	4 - 12	740	100	90	M24	M24	210	170	51	51	28	25	90	106	81	95	16	14
355 ML ₋	2	740	70	70	M20	M20	140	140	42	40	20	20	62.5	74.5	62.5	74.5	12	12
	4 - 12	740	100	90	M24	M24	210	170	51	51	28	25	90	106	81	95	16	14
355 LK ⁴⁾	2	740	70	70	M20	M20	140	140	42	40	20	20	62.5	74.5	62.5	74.5	12	12
	4 - 12	740	100	90	M24	M24	210	170	51	51	28	25	90	106	81	95	16	14
400 L ₋	2	814	80	70	M20	M20	170	140	42	40	22	20	71	85	67.5	79.5	12	12
	4 - 12	814	110	90	M24	M24	210	170	50	50	28	25	100	116	81	95	16	14
400 LK ⁴⁾	2	814	80	70	M20	M20	170	140	42	40	22	20	71	85	67.5	79.5	12	12
	4 - 12	814	100	90	M24	M24	210	170	50	50	28	25	90	106	81	95	16	14
450 L ₋	2	966	80	-	M20	-	170	-	42	-	22	-	71	85	-	-	14	-
	4 - 12	966	120	100	M24	M24	210	210	50	50	32	28	109	127	100	116	18	16

Motor size	Poles	HB ¹⁾	HB ²⁾	HB ³⁾	L	LA	LB	LC	LD ¹⁾	LD ²⁾	LD ³⁾	M	N	O	P	S	T
355 SM ₋	2	589	603	-	1409	25	1269	1559	397	397	-	740	680	130	800	23	6
	4 - 12	589	603	-	1479	25	1269	1659	467	467	-	740	680	130	800	23	6
355 ML ₋	2	589	603	-	1514	25	1374	1664	397	397	-	740	680	130	800	23	6
	4 - 12	589	603	-	1584	25	1374	1764	467	467	-	740	680	130	800	23	6
355 LK ⁴⁾	2	589	603	-	1764	25	1624	1914	397	397	-	740	680	130	800	23	6
	4 - 12	589	603	-	1834	25	1624	2014	467	467	-	740	680	130	800	23	6
400 L ₋	2	-	645	-	1851	26	1681	2001	458	458	-	940	880	150	1000	28	6
	4 - 12	-	645	-	1891	26	1681	2071	498	498	-	940	880	150	1000	28	6
400 LK ⁴⁾	2	-	645	-	1851	26	1681	2001	458	458	-	740	680	150	800	24	6
	4 - 12	-	645	-	1891	26	1681	2071	498	498	-	740	680	150	800	24	6
450 L ₋	2	-	719	843	2147	33	1937	-	-	485	520	1080	1000	180	1150	28	6
	4 - 12	-	719	843	2187	33	1977	2407	-	525	560	1080	1000	180	1150	28	6

Tolerances

D, DA ISO m6

N ISO js6 (315_)

F, FA ISO h9

¹⁾ Terminal box 370

²⁾ Terminal box 750

³⁾ Terminal box 1200

⁴⁾ Size with alternative dimensions

Dimension drawings

Foot- and flange-mounted cast iron motors, 355 - 450

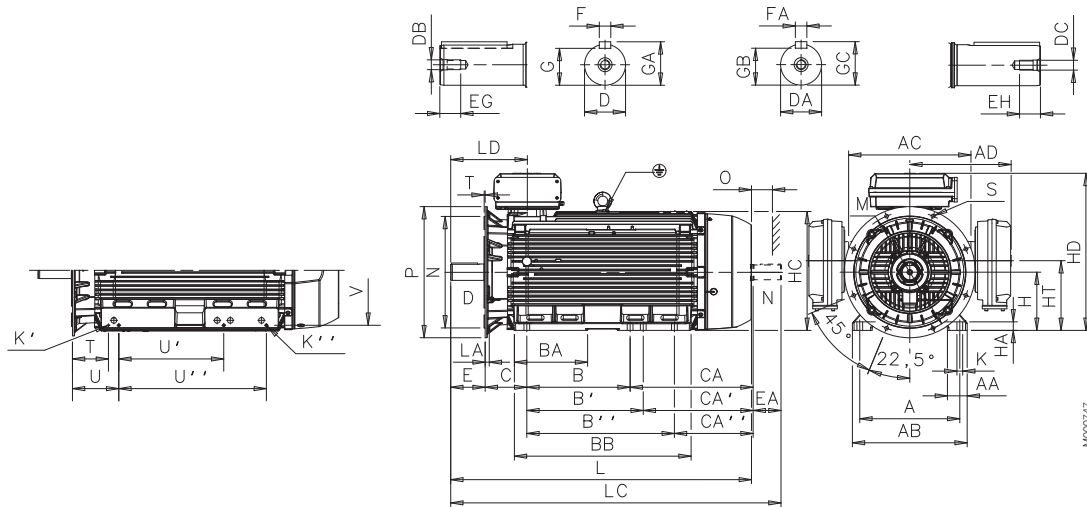

Mounting options: IM B35 (IM 2001), IM V15 (IM 2011), IM V36 (IM 2031)

Motor size	Poles	A	AA	AB	AC	AD ¹⁾	AD ²⁾	B	B'	B''	BA	BB	C	CA	CA'	CA''	D	DA	DB	DC	E	EA	EG	EH	F	FA
355 SM ₋	2	610	120	700	746	604	618	500	560	-	221	722	254	525	465	-	70	70	M20	M20	140	140	42	40	20	20
	4 - 12	610	120	700	746	604	618	500	560	-	221	722	254	525	465	-	100	90	M24	M24	210	170	51	51	28	25
355 ML ₋	2	610	120	700	746	604	618	560	630	-	267	827	254	500	570	-	70	70	M20	M20	140	140	42	40	20	20
	4 - 12	610	120	700	746	604	618	560	630	-	267	827	254	500	570	-	100	90	M24	M24	210	170	51	51	28	25
355 LK ₋₄₎	2	610	120	700	746	604	618	630	710	900	447	1077	254	750	670	480	70	70	M20	M20	140	140	42	40	20	20
	4 - 12	610	120	700	746	604	618	630	710	900	447	1077	254	750	670	480	100	90	M24	M24	210	170	51	51	28	25
400 L ₋	2	710	150	840	834	-	660	900	1000	-	410	1156	224	567	467	-	80	70	M20	M20	170	140	42	40	22	20
	4 - 12	710	150	840	834	-	660	900	1000	-	410	1156	224	567	467	-	110	90	M24	M24	210	170	50	51	28	25
400 LK ₋₄₎	2	686	150	840	834	-	660	710	800	900	410	1156	280	701	611	511	80	70	M20	M20	170	140	42	40	22	20
	4 - 12	686	150	840	834	-	660	710	800	900	410	1156	280	701	611	511	100	90	M24	M24	210	170	50	51	28	25
450 L ₋	2	800	160	950	966	-	-	1000	1120	1250	320	1300	250	-	-	-	80	-	M20	-	170	-	42	-	22	-
	4 - 12	800	160	950	966	-	-	1000	1120	1250	450	1420	250	737	617	487	120	100	M24	M24	210	210	50	50	32	28

Motor size	Poles	G	GA	GB	GC	H	HA	HC	HD ¹⁾	HD ²⁾	HD ³⁾	HD	K	K'	K''	L	LC	LD	LD	O	T	U	U'	U''	V
355 SM ₋	2	62.5	74.5	62.5	74.5	355	45	725	944	958	-	843	35	10	M16	1409	1559	397	679	130	120	280	560	-	670
	4 - 12	90	106	81	95	355	45	725	944	958	-	843	35	10	M16	1479	1659	467	750	130	120	282	560	-	670
355 ML ₋	2	62.5	74.5	62.5	74.5	355	45	725	944	958	-	843	35	10	M16	1514	1664	397	732	130	120	282	630	-	670
	4 - 12	90	106	81	95	355	45	725	944	958	-	843	35	10	M16	1584	1764	467	802	130	120	282	630	-	670
355 LK ₋₄₎	2	62.5	74.5	62.5	74.5	355	45	725	944	958	-	843	35	10	M16	1764	1914	397	857	130	120	282	630	890	670
	4 - 12	90	106	81	95	355	45	725	944	958	-	843	35	10	M16	1834	2014	467	927	130	120	282	630	890	670
400 L ₋	2	71	85	67.5	79.5	400	45	814	-	1045	-	943	35	10	M16	1851	2001	458	909	150	248	287	887	-	802
	4 - 12	90	116	81	95	400	45	814	-	1045	-	943	35	10	M16	1891	2071	498	949	150	248	287	887	-	802
400 LK ₋₄₎	2	71	85	67.5	79.5	400	45	814	-	1045	-	943	35	10	M16	1851	2001	458	909	150	248	287	748	916	802
	4 - 12	90	106	81	95	400	45	814	-	1045	-	943	35	10	M16	1891	2071	498	949	150	248	287	748	916	802
450 L ₋	2	71	85	-	-	450	46	933	-	1213	1281	-	40	10	M16	2027	-	450	-	180	274	290	861	-	912
	4 - 12	109	127	100	116	450	46	933	-	1169	1231	-	42	10	M16	2187	2407	525	-	180	274	323	841	-	912

Tolerances

A, B ± 0.8

D, DA ISO m6

F, FA ISO h9

Tolerances

H +0 -1.0

N ISO js6

C ± 0.8

¹⁾ Terminal box 370

²⁾ Terminal box 750

³⁾ Terminal box 1200

⁴⁾ Size with alternative dimensions

Accessories

Built-in brake (variant code 412)

Brake design

Electromagnetic disc brakes are applied by the action of a set of springs and are released when voltage is applied to the brake coil.

This means that the motor will brake automatically in case of any voltage failure, as significant safety feature. The brake is always functional, irrespective of the mounting position of the brake motor.

Detailed view

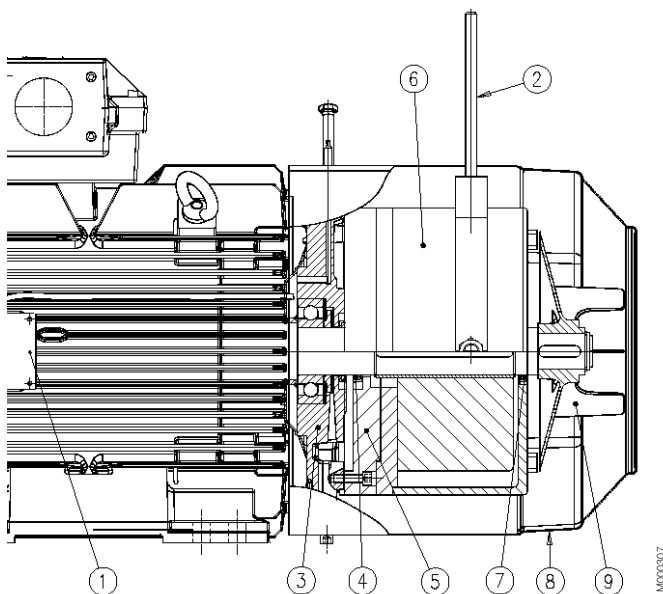

1. Connection box, (with rectifier, optional)
2. Manual release (optional)
3. Modified N-end shield
4. V-ring seal
5. Adapter flange for brake
6. Brake
7. V-ring seal
8. Fan cover
9. Fan

Brake disc

The brake linings are made of asbestos-free material. The linings are highly resistant to wear and have excellent thermal conductivity, providing consistent performance also in high temperatures.

The brake disc withstands a large number of braking instances and is insensitive to dust and moisture.

Note that changing from a used to a new disc will result in a different braking torque.

Replacing the brake disc

The brake disc must be replaced when the minimum permissible lining thickness has been reached. For minimum lining thickness, refer to the brake manufacturer's catalog.

Rectifier

Rectifier is a device for DC brake applications. It is highly resistant to temperature changes as well as to voltage peaks and has additional protection for the auxiliary contact of the contactor. Thanks to its compact design, it can be placed inside the motor's terminal box. Rectifier is an optional element.

Torque adjustment

Reducing the torque of the brake is possible with most brake types. Refer to the brake manufacturer's catalog or contact ABB for more information.

Manual release

Manual release bolts are provided as standard. A manual release handle is an optional element. Manual release overrides the action of brake springs as long as it is applied.

Though the manual release handle is optionally available for all motor sizes, it cannot be used in combination with the Pintsch Bamag brake type SFB.

Brake rating plates

The brake comes with two rating plates, one attached to the brake itself and another delivered loose, together with the motor. Variant code 412 is marked on the motor's rating plate (if it is listed among the five first codes on the motor order).

Available brake types

Motors can be fitted with recommended brakes from either Pintsch Bamag or Stromag, as seen in the tables below. Other brakes can be provided on request.

Brake type	Brake torque Nm	For motor size
KFB 10	100	160
KFB 16	160	160 - 180
KFB 25	250	180 - 225
KFB 40	400	200 - 250
KFB 63	630	225 - 280
KFB 1000	1000	280 - 315
KFB 1600	1600	315 - 355
On request		355 - 450

Pintsch & Bamag, type KFB, IP 67, 110 V DC Electromagnetic Double-Disc Spring-Applied Brake

Brake type	Brake torque Nm	For motor size
SFB 16	160	200 - 225
SFB 25	250	200 - 225
SFB 40	400	225 - 250
SFB 63	630	250
SFB 100	1000	280 - 315
SFB 160	1600	315 - 355
SFB 250	2500	355 - 400
SFB 400	4000	400
On request		450

Pintsch & Bamag, type SFB, IP 67, 110 V DC Electromagnetic Double-Disc Spring-Applied Brake

Brake type	Brake torque Nm	For motor size
NFF 10	100	160
NFF 16	160	160 - 180
NFF 25	250	180 - 225
NFF 40	400	200 - 250
NFF 63	630	225 - 250
For sizes 280-450 on request		

Stromag, type NFF, 110 V DC, IP66

Options for the brake

On new manufacture only

- Hand release (not possible for Pintsch Bamag brake type SFB)
- Rectifier
- Micro switch
- Proximity switch (not possible for Stromag brake)
- Standstill heater

On request

- Special brake voltage
- Raised brake torque
- Combination with brake, separate cooling fan and/or tachometer
- For other variants, please contact ABB.

Dimensions of brake motor

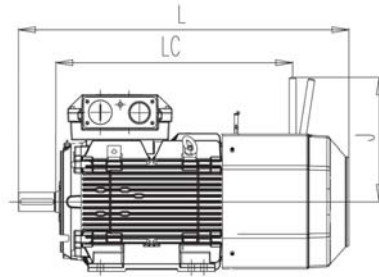

Foot-mounted: IM B3 (IM1001), IM B6 (IM 1051), IM B7 (IM1061), IM B8 (IM 1071), IM V5 (IM 1011), IM V6 (IM 1031)

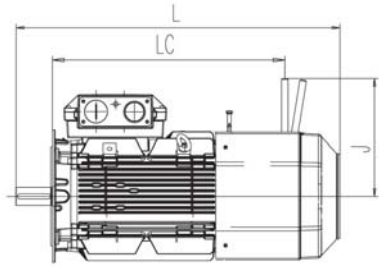

Flange-mounted: IM B5 (IM 3001), IM V1 (IM 3011), IM V3 (IM 3031), IM B14 (IM 3601), IM V18 (IM 3611), IM V19 (IM 3631)

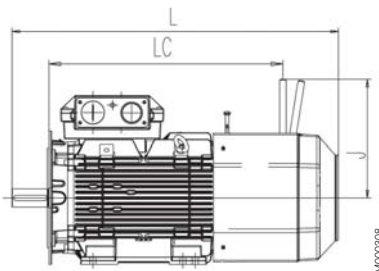

Foot- and flange-mounted: IM B35 (IM 2001), IM V15 (IM 2011), IM V36 (IM 2031)

Motor size	Poles	Foot-mounted			Flange-mounted			Foot- and flange-mounted		
		L	LC	J	L	LC	J	L	LC	J
160 ¹⁾	2-8	773	511	372	773	511	372	773	511	372
160 ²⁾	2-8	871	608	372	871	608	372	871	608	372
180	2-8	935	687	372	935	687	372	935	687	372
200	2-8	1011	695	460	1011	695	460	1011	695	460
225	2	1085	729	460	1085	729	460	1085	729	460
225	4-8	1115	729	460	1105	729	460	1115	729	460
250	2-8	1119	755	460	1119	755	460	1119	755	460

¹⁾ MLA-2, MLB-2, MLC-2, MLA-4, MLA-6, MLA-8 and MLB-8 -poles

²⁾ MLD-2, MLE-2, MLB-4, MLC-4, MLD-4, MLB-6, MLC-6 and MLC-8 -poles

Motor sizes 280 to 450 on request. Other dimensions same as Process performance cast iron motors sizes 180 to 250

Separate cooling

Axial fan, N-end

Fan motors with an axial fan are available for motor sizes 71-450 and can be ordered with variant code 183.

The values here are given for 400 V, but technical data for other voltages can be found in MotSize.

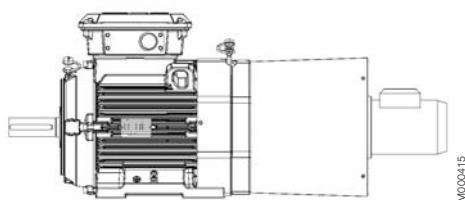

Axial fan, N-end, for motor sizes 71 - 132

Main motor	Fan motor type	Voltage range at 50 Hz, V	Voltage range at 60 Hz, V	Power W	Current A
M3BP 71	Wistro 132	380 - 500	380 - 575	29	0,06
		220 - 290	220 - 332	28	0,1
M3BP 80	Wistro 156	380 - 500	380 - 575	34	0,06
		220 - 290	220 - 332	34	0,10
M3BP 90	Wistro 169	380 - 500	380 - 575	75	0,19
		220 - 290	220 - 332	78	0,33
M3BP 100	Wistro 187	380 - 500	380 - 575	94	0,17
		220 - 290	220 - 332	87	0,31
M3BP 112	Wistro 210	380 - 500	380 - 575	99	0,17
		220 - 290	220 - 332	103	0,31
M3BP 132	Wistro 250	380 - 500	380 - 575	148	0,25
		220 - 290	220 - 332	146	0,45

Axial fan, N-end, for motor sizes 160 - 450

Main motor	Fan motor type (at 50 Hz)	Voltage V at 50 Hz	Power kW	Current A
M3BP 160 - 250	M2VA 63 B 4 B14	400	0.18	0,61
M3BP 280 - 315 ML	M3BP 80 MD 4 B14	400	0.75	1,83
M3BP 315 LK - 355 SM	M3BP 90 SLD 4 B14	400	1.5	3,0
M3BP 355 ML - 450 L	M3BP 100 LD 4 B14	400	3.0	6,3

Fan on top, N-end

The non-axial fan available for motor sizes 280 and above is a Ziehl-Abegg fan with an integrated motor. This cooling option is suited for 400 V, 50 Hz networks and can be ordered with variant code 422.

Fan on top, N-end, for motor sizes 280 - 450

Main motor	Fan motor type	Voltage V	Freq. Hz	Power kW	Current A
M3BP 280	Ziehl-Abegg RH35	400 VY	50	0.35	0.83
		460 VY	60	0.5	0.9
M3BP 315	Ziehl-Abegg RH40	400 VY	50	0.50	1.0
		460 VY	60	0.8	1.4
M3BP 355	Ziehl-Abegg RH45	400 VY	50	0.90	1.8
		460 VY	60	1.4	2.2
M3BP 400	Ziehl-Abegg RH50	400 VY	50	1.55	3.3
		460 VY	60	2.5	4.3
M3BP 450	Ziehl-Abegg RH56	400 VY	50	2.30	4.5
		460 VY	60	2.5	4.3

Special motor and fan on top, N-end

A special ABB fan motor type is available for motor sizes 280 and above. It is suited for environments where IP 65 is the required IP class or where the input voltage must be other than 360 - 420 V (50 Hz).

The values here are given for 400 V, but technical data for other voltages can be found in MotSize.

The centrifugal impeller used in the fan is a Ziehl-Abegg impeller. This type of cooling can be ordered with variant code 514.

Special motor and fan on top, N-end, for motor sizes 280 - 450

Main motor	Fan motor type	Voltage V at 50 Hz	Power kW	Current A
M3BP 280 - 315	M3BP 80 MD 4 B34	400	0.75	1.83
M3BP 355	M3BP 90 SLD 4 B34	400	1.5	3.0
M3BP 400	M3BP 100 LD 4 B34	400	3.0	6.3
M3BP 450	M3BP 112 MB 4 B34	400	4.0	8.2

Silencer for motor sizes 280 - 450

Both foot-mounted and flange-mounted motors can be fitted with a silencer to reduce noise level by about 5 - 6 dB(A). The silencer is painted blue and made of 2 mm steel sheet. The sound absorbing material is 40 mm thick polyurethane foam. On the rim there is a rubber strip for sealing on the floor. The silencer fits loosely over the motor.

The variant code for ordering a silencer is 055.

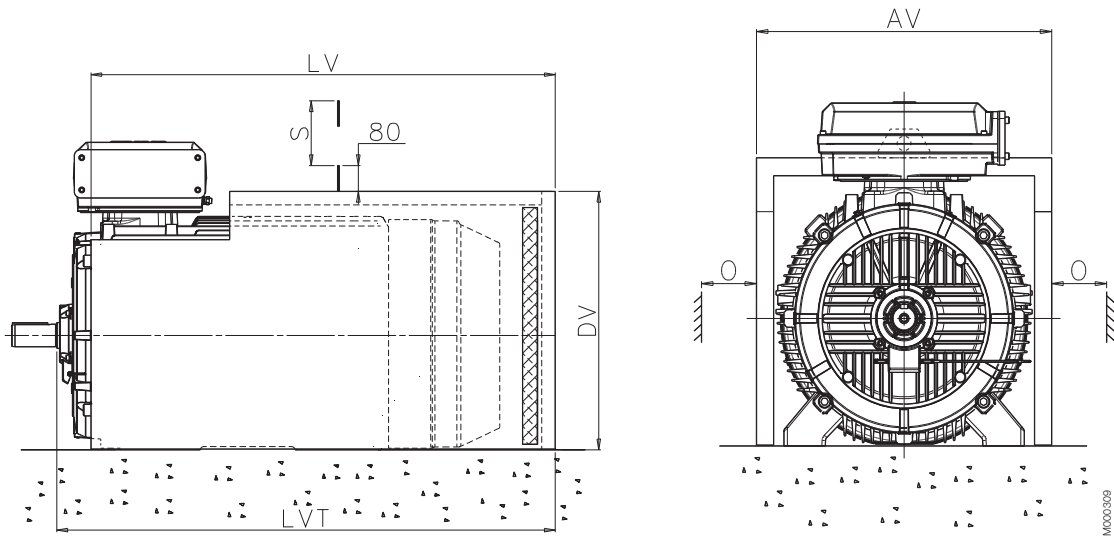

Motor size	AV	LV	LVT	DV	O ¹⁾	S ²⁾	Weight kg
280 SM_	681	1010	1090	616	50	762	38
315 SM_	760	1094	1191	697	60	852	47
315 ML_	760	1205	1302	697	60	852	51
315 LK_	760	1411	1508	697	60	852	58
355 SM_	850	1335	1441	777	65	958	62
355 ML_	850	1440	1546	777	65	958	67
355 LK_	850	1690	1796	777	65	958	77
400 L_	938	1750	1873	866	75	1045	88
400 LK_	938	1750	1873	866	75	1045	88
450 L_	1050	2110	2230	990	80	1045	120

¹⁾ Clearance for motor cooling.

²⁾ Clearance for removal of silencer.

Note: The dimensions are only valid for standard foot-mounted motors.

Slide rails for motor sizes 160 - 250

A set of slide rails includes two complete rails with screws for mounting the motor on the rails. Screws for mounting the rails on the foundation are not included. Slide rails have unmachined lower surfaces and should, before tightening down, be supported in a suitable manner.

Slide rails can be ordered with article numbers shown in the table.

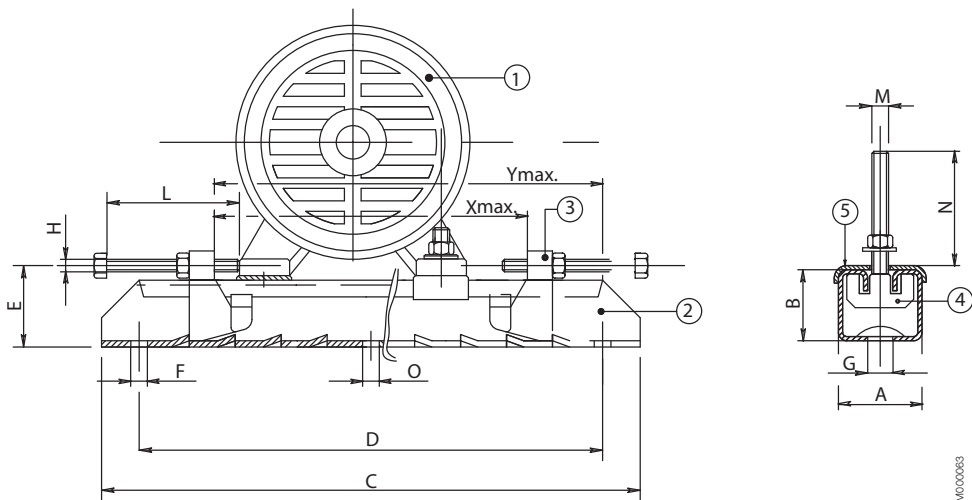

1 Motor | 2 Rail | 3 Movable adjusting bolt | 4 Fixing bolt, motor | 5 Plate

Motor size	Type	Article no. 3GZV103001-	A	B	C	D	E	F	G	H	L	M	N	O	Xmax	Ymax	Weight/ rail kg
Frame sizes 71 to 132 on request																	
160 - 180	TT180/12	-14	75	42	700	630	57	17	26	M12	120	M12	50	-	520	580	12.0
200 - 225	TT225/16	-15	82	50	864	800	68	17	27	M16	140	M16	65	17	670	740	20.4
250	TT280/20	-16	116	70	1072	1000	90	20	27	M18	150	M20	80	20	870	940	43.0

Slide rails for motor sizes 280 - 400

A set of slide rails includes two complete rails with screws for mounting the motor on the rails. Screws for mounting the rails on the foundation are not included. Slide rails have unmachined lower surfaces and should be supported in a suitable manner before tightening down.

Slide rails can be ordered with article numbers shown in the table.

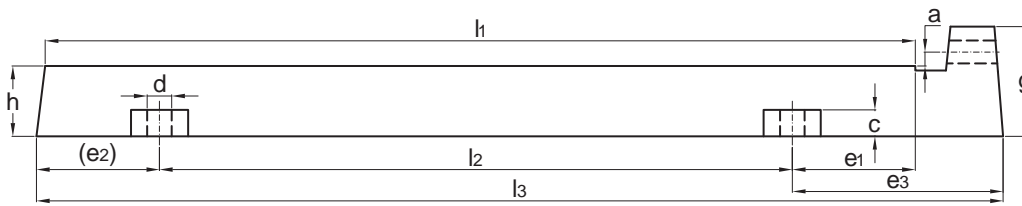

Slide rails for motor sizes 280 - 315.

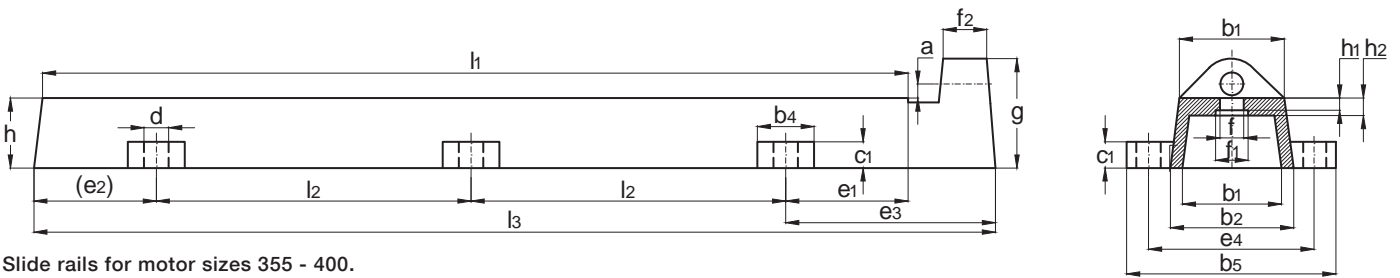

Slide rails for motor sizes 355 - 400.

Note: Slide rails that do not fulfill the DIN standard are available for motor size 450 on request.

Motor size	Article no.	l1	l2	l3	a	h	b1	b2	c	d	e1	e2	e3	e4	Bolts to feet	Horizontal bolts	Weight kg/2 pc
280	3GZF334730-55	800	600	900	16	75	100	120	35	28	100	100	200	165	M20×90	M24×300	50
315	3GZF334730-56	1000	720	1100	16	80	120	140	40	28	140	140	240	190	M24×100	M24×300	80
355 - 400	3GZF334730-57	1250	485	1350	16	80	120	140	35	28	140	140	240	190	M24×100	M24×300	90

Motors in brief

IE2 cast iron motors, sizes 71 - 132

The following tables present the standard design of IE2 cast iron motors.

Motor size		71	80	90	100	112	132
Stator and end shields	Material	Cast iron					
	Paint color shade	Munsell blue 8B 4.5/3.25					
	Corrosion class	C3 (medium)					
Feet		Integrated cast iron feet					
Bearings	D-end	6203-2Z/C3	6204-2Z/C3	6205-2Z/C3	6206-2Z/C3	6206-2Z/C	6208-2Z/C3
	N-end	6202-2Z/C3	6203-2Z/C3	6204-2Z/C3	6205-2Z/C3	6205-2Z/C3	6208-2Z/C3
Axially locked bearings		Locked at D-end					
Bearing seals	D-end	V-ring as standard					
	N-end	Labyrinth seal					
Lubrication		Permanently lubricated shielded bearings					
Measuring nipples for condition monitoring of the bearings		Not included					
Rating plate	Material	Stainless steel					
Terminal box	Frame and cover	Cast iron					
	Corrosion class	C3 (medium)					
	Cover screws	Zinc-electroplated steel					
Connections	Threaded openings	2 × M16	2 × M25	2 × M32			
	Terminals	6 terminals for connection with cable lugs (not included)					
	Cable glands	Cable flange included, glands as option					
Fan	Material	Glass-fiber reinforced polypropylene					
Fan cover	Material	Steel					
	Paint color shade	Munsell blue 8B 4.5/3.25					
	Corrosion class	C3 (medium)					
Stator winding	Material	Copper					
	Insulation	Insulation class F. Temperature rise class B unless otherwise stated.					
	Winding protection	3 PTC thermistors, 150 °C					
Rotor winding	Material	Pressure die-cast aluminum					
Balancing method		Half-key balancing as standard					
Keyway		Closed keyway					
Drain holes		Drain holes with closable plastic plugs, open on delivery					
Enclosure		IP 55					
Cooling method		IC 411					

Motors in brief

IE2/IE3 cast iron motors, sizes 160 - 250

Motor size		160	180	200	225	250
Stator and end shields	Material	Cast iron				
	Paint color shade	Munsell blue 8B 4.5/3.25				
	Corrosion class	C3 (medium)				
Feet	Material	Integrated cast iron feet, bolted feet when terminal box on LHS/RHS				
Bearings	D-end	6309/C3	6310/C3	6312/C3	6313/C3	6315/C3
	N-end	6209/C3	6209/C3	6210/C3	6212/C3	6213/C3
Axially locked bearings		Locked at D-end				
Bearing seals	D-end	Gamma-ring				
	N-end	V-ring				
Lubrication		Regreasable bearings, regreasing nipples M6 × 1				
Measuring nipples for condition monitoring of the bearings		Included				
Rating plate	Material	Stainless steel				
Terminal box	Frame and cover	Cast iron				
	Corrosion class	C3 (medium)				
	Cover screws	Zinc-electroplated steel				
Connections	Cable entries	2 × M40, 1 × M16		2 × M63, 1 × M16		
	Terminals	6 terminals for connection with cable lugs (not included)				
	Cable glands	Cable flange included, glands as option				
Fan	Material	Glass-fiber reinforced polypropylene				
Fan cover	Material	Steel				
	Paint color shade	Munsell blue 8B 4.5/3.25				
	Corrosion class	C3 (medium)				
Stator winding	Material	Copper				
	Insulation	Insulation class F. Temperature rise class B unless otherwise stated.				
	Winding protection	3 PTC thermistors, 150 °C				
Rotor winding	Material	Pressure die-cast aluminum				
Balancing method		Half-key balancing as standard				
Keyway		Closed keyway				
Drain holes		Drain holes with closable plastic plugs, open on delivery				
Enclosure		IP 55				
Cooling method		IC 411				

Motors in brief

IE2/IE3 cast iron motors, sizes 280 - 450

Motor size		280	315	355	400	450	
Stator and end shields	Material	Cast iron					
	Paint color shade	Munsell blue 8B 4.5/3.25					
	Corrosion class	C3 (medium)					
Feet	Material	Integrated cast iron feet					
Bearings	D-end	2-pole	6316/C3	6316/C3	6316M/C3	6317M/C3	6317M/C3
		4-12-pole	6316/C3	6319/C3	6322/C3	6324/C3	6326M/C3
	N-end	2-pole	6316/C3	6316/C3	6316M/C3	6317M/C3	6317M/C3
		4-12-pole	6316/C3	6316/C3	6316/C3	6319/C3	6322/C3
Axially locked bearings		Locked at D-end					
Bearing seals	D-end	V-ring or labyrinth seal					
	N-end	V-ring or labyrinth seal					
Lubrication		Regreasable bearings, regreasing nipples M10x1					
Measuring nipples for condition monitoring of the bearings		Included					
Rating plate	Material	Stainless steel					
Terminal box	Frame and cover	Cast iron				Cover steel	
	Corrosion class	C3 (medium)				Steel	
	Cover screws	Zinc-electroplated steel					
Connections	Cable-entries	2-4-pole	2 x M63	2 x M63, 2 x Ø48-60	2 x Ø48-60, 60-80	2 x Ø60-80 (2-6-pole)	2 x Ø60-80
		6-8-pole			2 x Ø32-49, 48-60	2 x Ø48-60 (8-pole)	
			See section Standard terminal box for detailed information.				
	Terminals	6 terminals for connection with cable lugs (not included)					
	Cable glands	Cable flange and glands included					
Fan	Material	Glass-fiber reinforced polypropylene					
Fan cover	Material	Steel					
	Paint color shade	Munsell blue 8B 4.5/3.25					
	Corrosion class	C3 (medium)					
Stator winding	Material	Copper					
	Insulation	Insulation class F. Temperature rise class B unless otherwise stated.					
	Winding protection	3 PTC thermistors, 155 °C					
Rotor winding	Material	Pressure die-cast aluminum					
Balancing method		Half-key balancing					
Keyway		Open keyway					
Drain holes		Drain holes with closable plastic plugs, open on delivery					
Enclosure		IP 55					
Cooling method		IC 411					

Motor construction

Process performance cast iron motors

Exploded view, frame size 315

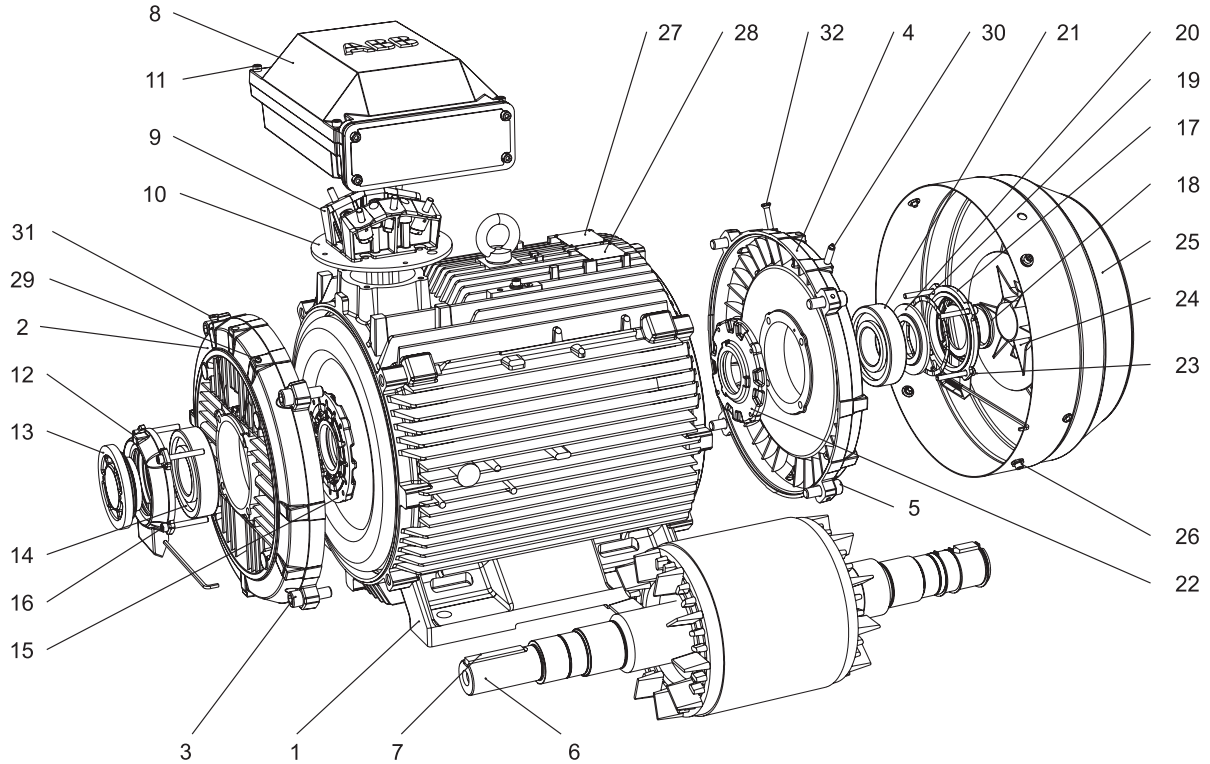

1	Stator frame	13	Valve disc with labyrinth seal, D-end; standard in 2-pole motors, V-ring in 4-8 pole motors	23	Screws for bearing cover
2	End shield, D-end	14	Bearing, D-end	24	Fan
3	Screws for end shield, D-end	15	Inner bearing cover, D-end	25	Fan cover
4	End shield, N-end	16	Screws for bearing cover	26	Screws for fan cover
5	Screws for end shield, N-end	17	Outer bearing cover, N-end	27	Rating plate
6	Rotor with shaft	18	Seal, N-end	28	Lubrication plate
7	Key, D-end	19	Wave spring	29	Grease nipple, D-end
8	Terminal box	20	Valve disc, N-end	30	Grease nipple, N-end
9	Terminal board	21	Bearing, N-end	31	SPM nipple, D-end
10	Intermediate flange	22	Inner bearing cover, N-end	32	SPM nipple, N-end
11	Screws for terminal box cover				
12	Outer bearing cover, D-end				

Process performance aluminum motors

Totally enclosed squirrel cage three phase low voltage motors

Sizes 63 to 280, 0.09 to 90 kW

Ordering information	82
Rating plates	83
Technical data IE2 AU MEPS	84
3000 r/min motors	84
1500 r/min motors	85
1000 r/min motors	86
750 r/min motors	87
Technical data IE3 AU high efficiency (HE) MEPS	86
3000, 1500, 1000 and 750 r/min motors	86
Variant codes	88
Mechanical design	94
Motor frame and drain holes	94
Bearings	95
Terminal box	103
Dimension drawings	105
Accessories	121
Slide rails	121
IE2/IE3 aluminum motors in brief	122



Ordering information

When placing an order, specify motor type, size and product code according to the following example.

Example	
Motor type	M3AA 112 MB
Pole number	4
Mounting arrangement (IM-code)	IM B3 (IM 1001)
Rated output	4 kW
Product code	3GAA 112312-ADE
Variant codes if needed	

Explanation of the product code

Motor type	Motor size	Product code	Code for mounting arrangement, Voltage and frequency code, Generation code followed by variant codes
M3AA	112MB	3GAA 112 312	- ADE, 122, 003, etc.
		1 2 3 4 5 6 7 8 9 10 11 12 13 14...	

Positions 1 to 4

3GAA: Totally enclosed motor with aluminum stator frame

Position 4

Type of rotor

A: Squirrel cage rotor

Positions 5 and 6

IEC size

06: 63

07: 71

08: 80

09: 90

10: 100

11: 112

13: 132

16: 160

18: 180

20: 200

22: 225

25: 250

28: 280

Position 7

Pole pairs

1: 2 poles

2: 4 poles

3: 6 poles

4: 8 poles

5: 10 poles

6: 12 poles

7: > 12 poles

8: Two-speed motors

9: Multi-speed motors

Positions 8 to 10

Running number

Position 11

- (dash)

Position 12 (marked with black dot in data tables)

Mounting arrangement

A: Foot-mounted motor

B: Flange-mounted motor. Large flange with clearance holes.

C: Flange-mounted motor. Small flange with tapped holes.

F: Foot- and flange-mounted motor. Special flange.

H: Foot- and flange-mounted motor. Large flange with clearance holes.

J: Foot- and flange-mounted motor. Small flange with tapped holes.

N: Flange-mounted (CI ring flange FF)

P: Foot-and flange-mounted motor (CI ring flange FF)

V: Flange-mounted motor. Special flange.

Position 13 (marked with black dot in data tables)

Voltage and frequency code

Single-speed motors

B: 380 VΔ 50 Hz

D: 400 VΔ, 415 VΔ, 690 VY 50 Hz

E: 500 VΔ 50 Hz

F: 500 VY 50 Hz

S: 230 VΔ, 400 VY, 415 VY 50 Hz

T: 660 VΔ 50 Hz

U: 690 VΔ 50 Hz

X: Other rated voltage, connection or frequency, 690 V maximum

Two-speed motors

A: 220 V 50 Hz

B: 380 V 50 Hz

D: 400 V 50 Hz

E: 500 V 50 Hz

S: 230 V 50 Hz

X: Other rated voltage, connection or frequency, 690 V maximum

Remark: For voltage code X the variant code "209 Non-standard voltage or frequency (special winding)" must be ordered.

Position 14

Version

A,B,C...: Generation code followed by variant codes

Rating plates

The motor's main rating plate shows the motor's performance values with various connections at nominal speed. The rating plate also shows the efficiency level (IE2, IE3, or IE4), year of manufacture, and the lowest nominal efficiency at 100, 75, and 50 % nominal load. The material of the rating plate is aluminum as standard.

ABB		IE2 CE				
3~Motor		M3AA 225 SMA 4				
		2011				
No.		3GV1124367690001				
		ins. c F				
		IP 55				
V	H _z	kW	r/min	A	cos ϕ	duty
400	Δ 50	37	1479	68	0,84	S1
690	Y 50	37	1479	39,4	0,84	S1
415	Δ 50	37	1481	68	0,81	S1
480	Δ 60	37	1782	59,	0,84	S1
50 Hz: IE2 - 93,4(100%) - 93,8(75%) - 93,1(50%)						
60 Hz: IE2 - 93,8(100%) - 93,5(75%) - 92,5(50%)						
3GAA 222 031-ADG						
6313-2Z/C3		6212-2Z/C3		240 kg		
spare-parts:www.abb.com/partsonline				IEC 60034-1		

Example of a standard motor rating plate

Technical data

IE2 aluminum motors according to AU MEPS, 3000 r/min

IP 55 - IC 411 - Insulation class F, temperature rise class B

IE2 efficiency class according to IEC 60034-30; 2008

Output kW	Motor type	Product code	Speed r/min	Efficiency IEC 60034-2-1; 2007			Power factor cos φ	Current		Torque			Moment of inertia J = 1/4 GD ² kgm ²	Weight kg	Sound pressure level L _{PA} dB
				Full load 100%	3/4 load 75%	1/2 load 50%		I _N A	I _s /I _N	T _N Nm	T _l /T _N	T _b /T _N			
3000 r/min = 2 poles				415 V 50 Hz				CENELEC-design							
0.18 ²⁾	M3AA 63 A	3GAA 061 311...C	2830	70.9	68.8	62.9	0.58	0.60	4.4	0.6	3.8	3.4	0.00013	54	3.9
0.25 ²⁾	M3AA 63 B	3GAA 061 312...C	2830	77.3	75.7	68.4	0.65	0.69	4.7	0.84	3.9	3.6	0.00016	54	4.4
0.37 ²⁾	M3AA 71 A	3GAA 071 311...E	2810	74.5	75.7	73.1	0.74	0.93	5.1	1.26	3.0	3.0	0.00035	58	4.9
0.55 ²⁾	M3AA 71 B	3GAA 071 312...E	2800	78.0	79.4	77.6	0.71	1.38	5.3	1.88	3.1	3.2	0.00045	58	5.9
0.75	M3AA 80 B	3GAA 081 442...E	2910	80.7	79.2	74.5	0.69	1.87	8.1	2.4	4.4	4.2	0.0090	10.5	60
1.1	M3AA 80 C	3GAA 081 443...E	2890	82.1	81.9	79.1	0.75	2.4	8.2	3.6	3.9	3.8	0.0011	11	60
1.5	M3AA 90 L	3GAA 091 442...E	2910	84.1	84.3	82.3	0.85	2.9	7.9	4.9	2.8	3.6	0.0024	16	63
2.2	M3AA 90 LB	3GAA 091 443...E	2890	84.3	84.8	83.8	0.86	4.2	7.2	7.2	2.7	3.4	0.0027	18	63
3	M3AA 100 LB	3GAA 101 442...E	2915	85.7	85.7	83.8	0.87	5.5	9.0	9.8	3.1	4.1	0.0050	25	62
4	M3AA 112 MB	3GAA 111 442...E	2890	85.4	86.6	86.5	0.92	7.0	8.1	13.2	2.7	3.0	0.0062	30	68
5.5	M3AA 132 SB	3GAA 131 442...E	2920	88.0	87.8	86.0	0.84	10.3	8.8	17.9	3.0	5.0	0.016	42	73
7.5	M3AA 132 SC	3GAA 131 443...E	2920	88.2	88.4	86.9	0.89	13.2	8.4	24.5	2.3	3.5	0.022	56	73
11	M3AA 160 MLA	3GAA 161 031...G	2935	89.8	90.4	89.8	0.90	18.9	8.0	35.7	2.6	3.3	0.044	91	69
15 ³⁾	M3AA 160 MLB	3GAA 161 036...G	2950	91.7	92.2	91.7	0.89	25.5	8.1	48.5	2.7	3.6	0.053	105	69
18.5 ³⁾	M3AA 160 MLC	3GAA 161 037...G	2946	92.1	92.9	92.7	0.89	31.3	8.0	59.9	3.1	3.6	0.063	123	69
22	M3AA 180 MLA	3GAA 181 031...G	2953	91.6	92.1	91.5	0.86	38.8	8.1	71.1	3.0	3.6	0.076	132	69
30 ³⁾	M3AA 200 MLA	3GAA 201 035...G	2963	92.9	93.4	93.1	0.89	50.4	8.3	96.6	3.0	3.4	0.178	210	72
37 ³⁾	M3AA 200 MLB	3GAA 201 036...G	2964	93.4	93.7	93.3	0.87	63.3	8.7	119	3.3	3.6	0.196	225	72
45	M3AA 225 SMA	3GAA 221 031...G	2968	93.3	93.2	92.0	0.87	77.1	7.1	144	2.7	2.7	0.244	263	74
55 ³⁾	M3AA 250 SMA	3GAA 251 031...G	2973	94.4	94.5	93.9	0.87	93.1	7.2	176	2.4	3.0	0.507	304	75
75	M3AA 280 SMA	3GAA 281 031...G	2972	94.4	94.4	93.6	0.88	125	7.5	240	2.7	3.1	0.583	389	75
90 ¹⁾³⁾	M3AA 280 SMB	3GAA 281 032...G	2972	94.8	95.1	94.7	0.88	150	8.4	289	2.9	3.4	0.644	425	75
3000 r/min = 2 poles				415 V 50 Hz				High-output design							
22	M3AA 160 MLD	3GAA 161 034...G	2932	91.4	92.1	92.2	0.92	36.3	8.5	71.6	3.4	3.9	0.063	123	69
27 ³⁾	M3AA 160 MLE	3GAA 161 035...G	2950	92.7	93.3	93.1	0.87	46.5	9.3	87.4	3.7	4.1	0.072	145	69
30 ³⁾	M3AA 180 MLB	3GAA 181 032...G	2957	92.4	93.1	92.8	0.85	53.1	8.3	96.8	3.0	3.6	0.092	149	69
45	M3AA 200 MLC	3GAA 201 033...G	2953	93.2	93.3	92.6	0.89	75.4	8.5	145	3.3	3.6	0.196	225	72
55 ¹⁾	M3AA 200 MLD	3GAA 201 034...G	2954	93.7	94.1	93.6	0.89	91.7	8.4	177	3.2	3.6	0.217	241	72
55	M3AA 225 SMB	3GAA 221 032...G	2966	93.8	93.8	93.0	0.87	93.7	7.0	177	2.6	2.7	0.274	286	74
75 ¹⁾³⁾	M3AA 225 SMC	3GAA 221 033...G	2975	94.8	94.9	94.3	0.80	137	7.6	240	3.4	3.3	0.309	312	74
75 ³⁾	M3AA 250 SMB	3GAA 251 032...G	2972	94.9	94.9	94.3	0.88	124	8.1	240	3.0	3.3	0.583	351	75
80 ¹⁾	M3AA 225 SMD	3GAA 221 034...G	2969	94.5	94.3	93.5	0.85	138	7.5	257	3.2	3.1	0.329	317	74
90 ¹⁾³⁾	M3AA 250 SMC	3GAA 251 033...G	2973	95.4	95.7	95.4	0.88	149	8.1	289	2.8	3.3	0.644	386	75

¹⁾ Temperature rise class F

²⁾ Output powers below 0.75 kW and above 185 kW are not subject to Australian MEPS requirement

³⁾ IE3 efficiency, also approved for Australian HE MEPS

Efficiency values are given according to IEC 60034-2 - 1; 2007

Technical data

IE2 aluminum motors according to AU MEPS, 1500 r/min

IP 55 - IC 411 - Insulation class F, temperature rise class B

IE2 efficiency class according to IEC 60034-30; 2008

Output kW	Motor type	Product code	Speed r/min	Efficiency IEC 60034-2-1; 2007			Power factor cos φ	Current		Torque			Moment of inertia J = 1/4 GD ² kgm ²	Weight kg	Sound pressure level L _{PA} dB
				Full load 100%	3/4 load 75%	1/2 load 50%		I _N A	I _s /I _N	T _N Nm	T ₁ /T _N	T ₂ /T _N			
1500 r/min = 4 poles				415 V 50 Hz				CENELEC-design							
0.12 ²⁾	M3AA 63 A	3GAA 062 311-...C	1400	64.3	58.3	50.6	0.53	0.48	3.3	0.81	3.0	3.2	0.00019	40	4.0
0.18 ²⁾	M3AA 63 B	3GAA 062 312-...C	1400	66.0	62.7	55.5	0.57	0.66	3.3	1.24	2.8	2.9	0.00026	40	4.5
0.25 ²⁾	M3AA 71 A	3GAA 072 311-...E	1370	65.0	65.5	61.2	0.70	0.76	4.0	1.74	2.1	2.3	0.00066	45	5.2
0.37 ²⁾	M3AA 71 B	3GAA 072 312-...E	1385	69.5	71.2	68.4	0.72	1.02	4.4	2.5	2.1	2.2	0.00080	45	5.9
0.55 ²⁾	M3AA 80 A	3GAA 082 311-...E	1385	72.5	74.8	72.9	0.72	1.46	4.6	3.8	1.9	2.4	0.0013	50	8.5
0.75	M3AA 80 E	3GAA 082 445-...E	1440	80.6	80.1	76.8	0.68	1.9	6.7	4.9	3.5	3.4	0.0020	15	54
1.1	M3AA 90 LB	3GAA 092 444-...E	1440	83.2	83.2	81.0	0.79	2.3	7.0	7.2	3.1	3.5	0.0043	16	50
1.5	M3AA 90 LD	3GAA 092 445-...E	1445	83.9	83.3	80.5	0.75	3.3	7.7	9.9	3.4	3.6	0.006	20	50
2.2	M3AA 100 LC	3GAA 102 443-...E	1455	86.1	85.4	82.7	0.77	4.6	7.5	14.4	3.0	3.6	0.009	25	54
3	M3AA 100 LD	3GAA 102 444-...E	1440	85.7	86.8	86.0	0.78	6.2	6.6	19.8	3.0	3.6	0.011	28	63
4	M3AA 112 MC	3GAA 112 443-...E	1450	87.4	87.8	86.6	0.76	8.3	7.2	26.3	3.4	4.0	0.013	34	64
5.5	M3AA 132 M	3GAA 132 442-...E	1465	88.8	89.1	87.9	0.80	10.7	6.5	35.8	2.1	2.8	0.038	48	66
7.5	M3AA 132 MA	3GAA 132 444-...E	1460	88.7	89.1	88.0	0.81	14.5	6.7	49	1.9	2.8	0.048	59	63
11	M3AA 160 MLA	3GAA 162 031-...G	1472	90.3	91.1	90.9	0.83	20.4	7.3	71.3	2.4	3.0	0.081	99	62
15 ³⁾	M3AA 160 MLB	3GAA 162 032-...G	1470	91.9	92.2	91.5	0.81	28	7.5	97.4	2.8	3.2	0.099	118	62
18.5	M3AA 180 MLA	3GAA 182 031-...G	1480	91.7	92.1	91.4	0.83	33.8	7.7	119	2.8	3.1	0.166	146	62
22 ³⁾	M3AA 180 MLB	3GAA 182 032-...G	1480	92.6	93.2	93.1	0.83	39.8	7.8	141	2.9	3.2	0.195	163	62
30 ³⁾	M3AA 200 MLA	3GAA 202 031-...G	1482	93.4	93.8	93.4	0.83	53.8	7.9	193	3.0	3.3	0.309	218	63
37	M3AA 225 SMA	3GAA 222 031-...G	1480	93.1	93.3	92.5	0.82	67.4	7.3	238	2.9	3.1	0.356	240	66
45 ³⁾	M3AA 225 SMB	3GAA 222 032-...G	1480	94.1	94.0	92.9	0.83	80.1	8.0	290	3.0	3.5	0.440	273	66
55 ³⁾	M3AA 250 SMA	3GAA 252 031-...G	1482	94.7	94.8	94.3	0.85	95	7.5	354	2.8	3.2	0.765	314	67
75 ¹⁾³⁾	M3AA 280 SMA	3GAA 282 031-...G	1482	94.8	95.0	94.4	0.82	134	7.4	483	3.0	3.2	0.866	389	67
90 ¹⁾	M3AA 280 SMB	3GAA 282 032-...G	1478	94.5	94.8	94.6	0.84	157	8.0	581	3.5	3.7	0.941	418	67
1500 r/min = 4 poles				415 V 50 Hz				High-output design							
0.55 ¹⁾	M3AA 71 C	3GAA 072 003-...E	1370	67.7	70.5	68.1	0.72	1.56	4.3	3.8	2.5	2.3	0.0011	45	6.5
18.5	M3AA 160 MLC	3GAA 162 033-...G	1467	91.4	92.2	91.9	0.83	33.9	7.1	120	3.3	3.5	0.110	127	62
22	M3AA 160 MLD	3GAA 162 034-...G	1466	91.8	92.5	92.3	0.83	40.1	7.3	143	2.7	3.1	0.125	140	62
30 ¹⁾	M3AA 180 MLC	3GAA 182 033-...G	1479	91.8	92.6	92.4	0.81	56.1	7.7	193	2.9	3.2	0.217	177	62
37 ³⁾	M3AA 200 MLB	3GAA 202 032-...G	1480	93.6	94.2	94.3	0.83	66.2	7.6	238	2.8	3.2	0.343	234	63
45	M3AA 200 MLC	3GAA 202 033-...G	1480	93.9	94.0	93.4	0.81	82.3	7.8	290	3.2	3.5	0.366	246	63
55	M3AA 225 SMC	3GAA 222 033-...G	1477	93.7	94.0	93.6	0.85	96	7.8	355	3.2	3.3	0.474	287	66
64	M3AA 225 SMD	3GAA 222 034-...G	1479	94.2	94.4	93.9	0.79	119	8.4	413	3.6	3.6	0.542	314	66
75 ¹⁾³⁾	M3AA 250 SMB	3GAA 252 032-...G	1482	94.8	95.0	94.4	0.82	134	7.6	483	3.0	3.4	0.866	350	67
90 ¹⁾	M3AA 250 SMC	3GAA 252 033-...G	1478	94.8	95.0	94.4	0.82	161	7.7	581	3.4	3.6	0.941	377	67

¹⁾ Temperature rise class F

²⁾ Output powers below 0.75 kW and above 185 kW are not subject to Australian MEPS requirement

³⁾ IE3 efficiency, also approved for Australian HE MEPS

Efficiency values are given according to IEC 60034-2 - 1; 2007

Technical data

IE2 aluminum motors according to AU MEPS, 1000 r/min

IP 55 - IC 411 - Insulation class F, temperature rise class B

IE2 efficiency class according to IEC 60034-30; 2008

Output kW	Motor type	Product code	Speed r/min	Efficiency IEC 60034-2-1; 2007			Power factor cos φ	Current		Torque			Moment of inertia J = 1/4 GD ² kgm ²	Weight kg	Sound pressure level L _{PA} dB
				Full load 100%	3/4 load 75%	1/2 load 50%		I _N A	I _s /I _N	T _N Nm	T _L /T _N	T _b /T _N			
1000 r/min = 6 poles				415 V 50 Hz				CENELEC-design							
0.09 ²⁾	M3AA 63 A	3GAA 063 311-...C	925	44.9	40.3	29.9	0.52	0.53	2.2	0.94	2.3	2.3	0.00020	38	4.0
0.12 ²⁾	M3AA 63 B	3GAA 063 312-...C	925	54.8	51.3	43.5	0.54	0.56	2.2	1.25	2.3	2.3	0.00027	38	4.5
0.18 ²⁾	M3AA 71 A	3GAA 073 311-...E	895	58.7	58.8	53.2	0.67	0.63	3.1	1.94	1.9	2.1	0.00092	42	5.5
0.25 ²⁾	M3AA 71 B	3GAA 073 312-...E	900	62.6	61.5	55.5	0.68	0.81	3.4	2.6	2.3	2.4	0.0012	42	6.5
0.37 ²⁾	M3AA 80 A	3GAA 083 311-...E	910	67.8	69.2	65.7	0.70	1.08	3.6	3.9	1.8	2.2	0.0020	47	9.0
0.55 ²⁾	M3AA 80 B	3GAA 083 312-...E	910	68.5	70.3	67.1	0.69	1.61	3.4	5.8	1.7	2	0.0026	47	10
0.75	M3AA 90 LB	3GAA 093 443-...E	935	76.1	76.0	72.7	0.71	1.93	4.1	7.6	2.2	2.5	0.0048	18	44
1.1	M3AA 90 LD	3GAA 093 444-...E	945	78.3	78.2	75.4	0.71	2.7	4.7	11.1	2.3	2.5	0.0056	20	48
1.5	M3AA 100 LC	3GAA 103 442-...E	950	79.8	80.4	78.3	0.72	3.6	4.1	15.0	1.8	2.2	0.0090	26	49
2.2	M3AA 112 MB	3GAA 113 442-...E	965	83.0	82.3	79.1	0.64	5.7	5.3	21.7	2.1	2.4	0.010	34	56
3 ³⁾	M3AA 132 MA	3GAA 133 442-...E	975	85.9	85.6	83.4	0.68	7.1	6.2	29.3	2.4	3.7	0.038	46	57
4	M3AA 132 MB	3GAA 133 443-...E	980	85.9	84.6	81.2	0.58	11.1	5.5	38.9	2.3	3.2	0.045	54	57
5.5 ³⁾	M3AA 132 MC	3GAA 133 444-...E	975	88.7	88.6	87.0	0.68	12.6	5.6	53.8	1.8	3.5	0.049	59	61
7.5 ³⁾	M3AA 160 MLA	3GAA 163 031-...G	977	88.7	89.2	88.6	0.76	15.4	7.8	73.3	1.9	3.4	0.087	98	59
11 ³⁾	M3AA 160 MLB	3GAA 163 032-...G	980	89.7	90.3	89.8	0.74	23	8.0	107	2.1	3.2	0.114	125	59
15 ³⁾	M3AA 180 MLA	3GAA 183 033-...G	979	90.8	91.3	90.9	0.75	30.6	6.1	146	1.9	2.9	0.168	148	59
18.5 ³⁾	M3AA 200 MLA	3GAA 203 031-...G	987	92.1	92.2	91.3	0.78	35.8	7.0	178	2.5	3.1	0.382	196	63
22 ³⁾	M3AA 200 MLB	3GAA 203 032-...G	988	92.4	92.6	91.9	0.81	40.8	7.0	212	2.4	3.0	0.448	218	63
30	M3AA 225 SMA	3GAA 223 031-...G	987	92.1	92.6	92.2	0.81	55.9	7.4	290	2.8	3.1	0.663	266	63
37	M3AA 250 SMA	3GAA 253 031-...G	991	93.1	93.1	92.3	0.79	69.9	7.1	356	2.6	2.9	1.130	294	63
45 ³⁾	M3AA 280 SMA	3GAA 283 031-...G	991	93.2	93.7	93.4	0.82	81.9	7.2	433	2.6	2.8	1.369	378	63
55 ¹⁾³⁾	M3AA 280 SMB	3GAA 283 032-...G	990	93.6	94.1	93.9	0.82	99.6	7.6	530	2.8	3.0	1.500	404	63
1000 r/min = 6 poles				415 V 50 Hz				High-output design							
0.37 ²⁾	M3AA 71 C	3GAA 073 003-...E	905	62.7	62.1	56.4	0.63	1.3	3.7	3.9	2.6	2.8	0.0015	44	7.0
15	M3AA 160 MLC	3GAA 163 033-...G	975	89.2	90.2	90.0	0.74	31.6	7.7	146	2.0	3.9	0.131	138	59
18.5 ³⁾	M3AA 180 MLB	3GAA 183 034-...G	978	90.8	91.6	91.4	0.77	36.8	6.2	180	1.9	2.9	0.198	162	59
30 ¹⁾	M3AA 200 MLC	3GAA 203 033-...G	987	91.8	92.2	90.4	0.80	56.8	7.2	290	2.5	3.1	0.531	245	63
37 ³⁾	M3AA 225 SMB	3GAA 223 034-...G	987	93.0	93.7	93.5	0.83	66.6	7.1	357	2.5	2.9	0.821	300	63
45 ¹⁾	M3AA 225 SMC	3GAA 223 033-...G	985	92.7	93.0	92.7	0.82	82.3	6.9	436	2.5	2.8	0.821	300	63
45 ³⁾	M3AA 250 SMB	3GAA 253 032-...G	990	93.8	94.4	94.5	0.80	83.4	7.5	434	2.7	2.9	1.369	341	63
55 ¹⁾	M3AA 250 SMC	3GAA 253 033-...G	988	93.3	93.8	93.1	0.82	100	7.6	531	2.8	3.0	1.500	367	63

¹⁾ Temperature rise class F

²⁾ Output powers below 0.75 kW and above 185 kW are not subject to Australian MEPS requirement

³⁾ IE3 efficiency, also approved for Australian HE MEPS

Efficiency values are given according to IEC 60034-2 - 1; 2007

Technical data

IE2 aluminum motors according to AU MEPS, 750 r/min

IP 55 - IC 411 - Insulation class F, temperature rise class B

IE2 efficiency class according to IEC 60034-30; 2008

Output kW	Motor type	Product code	Speed r/min	Efficiency IEC 60034-2-1; 2007			Power factor cos φ	Current					Torque T _N Nm	Moment of inertia J = 1/4 GD ² kgm ²	Weight kg	Sound pressure level L _{PA} dB
				Full load 100%	3/4 load 75%	1/2 load 50%		I _N A	I _s / I _N	T _N Nm	T ₁ / T _N	T ₂ / T _N				
750 r/min = 8 poles				415 V 50 Hz				CENELEC-design								
0.09 ²⁾	M3AA 71 A	3GAA 074 001-...E	680	47.3	43.2	35.7	0.55	0.48	2.5	1.27	2.4	2.3	0.00092	40	5.5	
0.12 ²⁾	M3AA 71 B	3GAA 074 002-...E	675	50.2	47.0	39.6	0.57	0.58	2.5	1.72	2.4	2.3	0.0012	43	6.5	
0.18 ²⁾	M3AA 80 A	3GAA 084 001-...E	695	56.3	53.7	46.8	0.58	0.76	2.9	2.4	2.5	2.5	0.0018	45	8.5	
0.25 ²⁾	M3AA 80 B	3GAA 084 002-...E	695	60.7	58.7	52.1	0.57	1.00	3.2	3.4	2.7	2.7	0.0024	50	9.5	
0.37 ¹⁾²⁾	M3AA 90 S	3GAA 094 001-...E	700	56.2	51.9	43.8	0.51	1.79	2.7	5.0	1.8	2.3	0.0032	52	13	
0.55 ²⁾	M3AA 90 L	3GAA 094 002-...E	675	59.1	57.5	51.6	0.55	2.3	2.2	7.9	1.6	1.8	0.0043	52	16	
0.75 ³⁾	M3AA 100 LB	3GAA 104 442-...E	715	77.7	76.4	72.1	0.61	2.2	4.0	10.0	2.3	2.8	0.008	23	46	
1.5	M3AA 112 MB	3GAA 114 442-...E	695	77.9	77.6	75.1	0.69	3.8	3.7	20.6	2.0	2.6	0.010	28	52	
2.2	M3AA 132 MB	3GAA 134 443-...E	730	81.2	79.9	76.2	0.58	6.5	5.1	28.7	2.1	4.3	0.049	54	58	
3	M3AA 132 MC	3GAA 134 444-...E	725	82.8	82.4	79.5	0.63	7.9	5.2	39.5	2.0	3.7	0.049	59	61	
4	M3AA 160 MLA	3GAA 164 031-...G	732	83.9	84.2	82.9	0.63	10.5	5.6	52.1	1.7	2.9	0.068	84	59	
5.5	M3AA 160 MLB	3GAA 164 032-...G	726	84.9	85.5	84.7	0.63	14.3	5.7	72.3	1.5	2.9	0.085	98	59	
7.5	M3AA 160 MLC	3GAA 164 033-...G	730	86.8	87.3	86.6	0.65	18.4	4.9	98.1	1.6	3.1	0.132	137	59	
15 ³⁾	M3AA 200 MLA	3GAA 204 031-...G	739	89.8	90.4	90.1	0.70	33.1	5.5	193	2.2	2.6	0.450	217	60	
18.5 ³⁾	M3AA 225 SMA	3GAA 224 031-...G	740	91.4	91.5	90.6	0.71	39.6	5.6	238	2.2	2.5	0.669	266	63	
22 ³⁾	M3AA 225 SMB	3GAA 224 032-...G	739	91.4	91.5	90.5	0.72	46.5	5.8	284	2.2	2.5	0.722	279	63	
30	M3AA 250 SMA	3GAA 254 031-...G	741	92.1	91.9	90.5	0.70	64.7	6.1	386	2.8	2.6	1.404	340	63	
37 ³⁾	M3AA 280 SMA	3GAA 284 031-...G	742	92.8	93.1	92.5	0.71	78.1	5.9	476	2.6	2.5	1.505	403	63	
750 r/min = 8 poles				415 V 50 Hz				High-output design								
0.18 ²⁾	M3AA 71 C	3GAA 074 003-...E	670	48.7	46.5	39.2	0.61	0.84	2.7	2.6	2.3	2.2	0.0015	40	7.0	
0.37 ²⁾	M3AA 80 C	3GAA 084 003-...E	690	62.8	62.0	56.3	0.60	1.36	3.3	5.1	2.5	2.5	0.0031	45	11	

¹⁾ Temperature rise class F

²⁾ Output powers below 0.75 kW and above 185 kW are not subject to Australian MEPS requirement

³⁾ IE3 efficiency, also approved for Australian HE MEPS

Efficiency values are given according to IEC 60034-2 - 1; 2007

Variant codes

Aluminum motors

Variant codes specify additional options and features to the standard motor. The desired features are listed as three-digit variant codes in the motor order. Note also that there are variants that cannot be used together.

Most of the variant codes apply to IE2, IE3, and IE4 motors. However, confirm the availability of variants for IE3 and IE4 motors with your ABB sales office before making an order.

Code/ Variant, M3AA	Frame size												
	63	71	80	90	100	112	132	160	180	200	225	250	280
Administration													
530 Two-year extension on standard warranty	NA	NA	NA	NA	NA	NA	NA	R	R	R	R	R	R
Balancing													
417 Vibration acc. to Grade B (IEC 60034-14).	NA	NA	NA	P	P	R	R	R	R	R	R	R	R
423 Balanced without key.	NA	NA	NA	P	P	P	P	P	P	P	P	P	P
424 Full-key balancing	NA	NA	NA	P	P	P	P	P	P	P	P	P	P
426 Half key balancing.	NA	NA	NA	NA	NA	NA	NA	S	S	S	S	S	S
Bearings and Lubrication													
036 Transport lock for bearings.	NA	NA	NA	M	M	M	M	M	M	M	M	M	M
037 Roller bearing at D-end.	NA	NA	NA	M	P	P	P	M	M	M	M	M	M
038 Ball bearing at D-end.	NA	NA	NA	NA	NA	NA	NA	S	S	S	S	S	S
039 Cold-resistant grease	NA	NA	NA	M	M	M	M	NA	NA	NA	NA	NA	NA
040 Heat-resistant grease	NA	NA	NA	M	M	M	M	NA	NA	NA	NA	NA	NA
041 Bearings regreasable via grease nipples.	NA	NA	NA	P	P	M	M	M	M	M	M	M	S
042 Locked D-end	S	S	S	S	S	M	M	S	S	S	S	S	S
043 SPM compatible nipples for vibration measurement	NA	NA	NA	R	R	M	M	M	M	M	M	M	S
057 2RS bearings at both ends.	NA	NA	NA	M	M	M	M	M	M	M	M	M	M
058 Angular contact bearing at D-end, shaft force away from bearing.	NA	NA	NA	M	M	M	M	M	M	M	M	M	M
059 Angular contact bearing at N-end, shaft force towards bearing.	NA	NA	NA	M	M	M	M	M	M	M	M	M	M
188 63-series bearings.	NA	NA	NA	M	S	S	M	S	S	S	S	S	S
194 2Z bearings greased for life at both ends.	NA	NA	NA	NA	NA	NA	NA	S	S	S	S	S	M
195 Bearings greased for life.	NA	NA	NA	NA	NA	NA	NA	S	S	S	S	S	NA
796 Grease nipples JIS B 1575 PT 1/8 Type A	NA	NA	NA	NA	NA	M	M	M	M	M	M	M	M
797 Stainless steel SPM nipples	NA	NA	NA	R	R	M	M	M	M	M	M	M	M
798 Stainless steel grease nipples	NA	NA	NA	NA	NA	M	M	M	M	M	M	M	M
Brakes													
412 Built-in brake.	NA	NA	NA	NA	NA	NA	NA	P	P	NA	NA	NA	NA
Branch standard designs													
071 Cooling Tower duty	NA	NA	NA	NA	NA	P	P	P	P	P	P	P	P
079 Silumin-alloy rotor cage.	NA	NA	NA	P	P	R	R	NA	NA	NA	NA	NA	NA
142 Manilla connection.	NA	NA	NA	P	P	P	P	P	P	P	P	P	P
172 Smoke venting specification, 300 °C, 1 hour, DOL use, class F300 according to EN 12101-3	NA	NA	NA	NA	NA	NA	NA	R	R	R	R	R	NA
174 Smoke venting specification, 400 °C, 2 hours, DOL use, class F400 according to EN 12101-3	NA	NA	NA	NA	NA	NA	NA	R	R	R	R	R	NA
176 Smoke Venting specification, 300°C, 2 hours, DOL use, Class F300 (120) according to EN 12101-3	NA	NA	NA	R	R	R	R	NA	NA	NA	NA	NA	NA
178 Stainless steel / acid proof bolts.	M	NA	NA	P	P	P	P	M	M	M	M	M	M
199 Extreme heavy duty design.	NA	NA	NA	NA	NA	M	NA	R	R	R	R	R	R
209 Non-standard voltage or frequency, (special winding).	NA	NA	NA	P	P	P	P	P	P	P	P	P	P
217 Cast iron D-end shield (on aluminum motor).	NA	NA	NA	M	M	M	M	S	S	S	S	S	S
232 Cast iron N-end shield (on aluminium motor).	NA	NA	NA	R	R	R	R	NA	NA	NA	NA	NA	NA
387 Smoke venting specification, 300 °C, 1 hour, VSD use, Class F300 according to EN 12101-3	NA	NA	NA	NA	NA	NA	NA	R	R	R	R	R	NA
389 Smoke Venting specification, 400 °C, 2 hours, VSD use, Class F400 according to EN 12101-3	NA	NA	NA	NA	NA	NA	NA	R	R	R	R	R	NA

S: Included as standard
P: New manufacture only
M: On modification of a stocked motor; or on new manufacture, the number per order may be limited
R: On request
NA: Not applicable

Code/ Variant, M3AA	Frame size												
	63	71	80	90	100	112	132	160	180	200	225	250	280
392 Smoke Venting specification, 250 °C, 2 hours, DOL use, Class T250	NA	NA	NA	NA	NA	NA	NA	R	R	R	R	R	NA
393 Smoke venting specification, 250 °C, 2 hours, VSD use, Class T250	NA	NA	NA	NA	NA	NA	NA	R	R	R	R	R	NA
425 Corrosion protected stator and rotor core.	P	P	P	P	P	P	P	P	P	P	P	P	P
983 Shock resistant design	NA	NA	NA	NA	NA	NA	NA	NA	NA	P	P	P	NA
Cooling system													
046 Two-directional fan.	NA	NA	NA	NA	NA	NA	NA	S	S	S	S	S	S
053 Metal fan cover.	S	M	M	M	M	M	M	S	S	S	S	S	S
068 Light alloy metal fan	R	NA	NA	M	M	M	M	M	M	M	M	M	M
075 Cooling method IC418 (without fan).	NA	NA	NA	P	P	M	M	M	M	M	M	M	M
183 Separate motor cooling (fan axial, N-end).	NA	NA	NA	M	M	P	P	M	M	M	M	M	M
189 Separate motor cooling, IP44, 400V, 50Hz (fan axial, N-end).	NA	NA	NA	NA	NA	NA	NA	M	M	M	M	M	M
205 Non metallic fan	NA	NA	NA	NA	NA	NA	NA	S	S	S	S	S	S
792 Metal fasteners for fan cover	NA	NA	NA	NA	NA	NA	NA	S	S	S	S	S	S
793 Fan for reduced noise level (2-p fan).	NA	NA	NA	NA	NA	NA	NA	R	R	R	R	R	R
794 Fan for reduced noise level (4-p fan).	NA	NA	NA	NA	NA	NA	NA	R	R	R	R	R	R
Coupling													
035 Assembly of customer supplied coupling-half.	NA	NA	NA	R	R	R	R	NA	NA	NA	NA	NA	NA
Documentation													
141 Binding dimension drawing.	M	M	M	M	M	M	M	M	M	M	M	M	M
Drain holes													
065 Plugged existing drain holes.	NA	NA	NA	M	M	M	M	M	M	M	M	M	M
Earthing Bolt													
067 External earthing bolt.	NA	NA	NA	M	M	M	M	M	M	M	M	M	M
Hazardous Environments													
452 DIP/Ex tD acc. to ATEX directive 94/9/EC , T= 125 °C, cat. 3D, IP55	NA	NA	NA	P	P	P	M	M	M	M	M	M	M
454 DIP/Ex tD acc. to ATEX directive 94/9/EC , T= 125 °C, cat. 3D, IP65	NA	NA	NA	NA	NA	NA	M	NA	NA	NA	NA	NA	NA
480 Ex nA II acc. to ATEX directive 94/9/EC, temp. class T3.	NA	NA	NA	M	M	M	M	M	M	M	M	M	M
Heating elements													
450 Heating element, 100-120 V	NA	NA	NA	M	M	M	M	M	M	M	M	M	M
451 Heating element, 200 - 240 V	NA	NA	NA	M	M	M	M	M	M	M	M	M	M
Insulation system													
014 Winding insulation class H.	NA	NA	NA	P	P	P	P	P	P	P	P	P	P
405 Special winding insulation for frequency converter supply.	R	R	R	P	P	P	P	P	P	P	P	P	P
406 Winding for supply > 690 <= 1000 volts	NA	NA	NA	NA	NA	NA	NA	NA	NA	P	P	P	P
Marine													
024 Fulfilling Bureau Veritas (BV) requirements, with certificate.	NA	NA	NA	M	M	M	M	P	P	P	P	P	P
025 Fulfilling Det Norske Veritas (DNV) requirements, with certificate.	NA	NA	NA	M	M	M	M	P	P	P	P	P	P
026 Fulfilling Lloyds Register of Shipping (LR) requirements, with certificate.	NA	NA	NA	M	M	M	M	P	P	P	P	P	P
027 Fulfilling American Bureau of Shipping (ABS) requirements, with certificate.	NA	NA	NA	M	M	M	M	P	P	P	P	P	P
049 Fulfilling Germanischer Lloyd (GL) requirements, with certificate.	NA	NA	NA	M	M	M	M	P	P	P	P	P	P
050 Fulfilling Registro Italiano Navale (RINA) requirements, with certificate.	NA	NA	NA	M	M	M	M	P	P	P	P	P	P
051 Fulfilling Russian Maritime Register of Shipping (RS) requirements, with certificate.	NA	NA	NA	NA	NA	NA	NA	P	P	P	P	P	P
096 Fulfilling Lloyds Register of Shipping (LR) requirements, without certificate (non-essential duty only)	M	M	M	M	M	M	M	M	M	M	M	M	P
186 Fulfilling Det Norske Veritas (DNV) requirements, without certificate (non-essential duty only)	M	M	M	M	M	M	M	M	M	M	M	M	M
481 Fulfilling Nippon Kaiji Kyokai (NK) requirements, with certificate.	NA	NA	NA	M	M	M	M	P	P	P	P	P	P
483 Fulfilling China Classification Societies (CCS) requirements (Beijing), with certificate.	NA	NA	NA	M	M	M	M	P	P	P	P	P	P
484 Fulfilling Korea Register of Shipping (KR) requirements, with certificate.	NA	NA	NA	M	M	M	M	P	P	P	P	P	P
491 Fulfilling Nippon Kaiji Kyokai (NK) requirements, without certificate.	NA	NA	NA	M	M	M	M	M	M	M	M	M	M
492 Fulfilling Registro Italiano Navale (RINA) requirements, without certificate.	NA	NA	NA	M	M	M	M	M	M	M	M	M	M
493 Fulfilling China Classification Societies (CCS) requirements (Beijing), without certificate.	NA	NA	NA	M	M	M	M	M	M	M	M	M	M
494 Fulfilling Korea Register of Shipping (KR) requirements, without certificate.	NA	NA	NA	M	M	M	M	M	M	M	M	M	M

S: Included as standard
P: New manufacture only
M: On modification of a stocked motor; or on new manufacture, the number per order may be limited
R: On request
NA: Not applicable

Code/ Variant, M3AA	Frame size												
	63	71	80	90	100	112	132	160	180	200	225	250	280
496 Fulfilling Bureau Veritas (BV) requirements, without certificate (non-essential duty only)	M	M	M	M	M	M	M	M	M	M	M	M	P
675 Fulfilling American Bureau of Shipping (ABS) requirements, without certificate (non-essential duty only)	NA	NA	NA	M	M	M	M	M	M	M	M	M	P
676 Fulfilling Germanischer Lloyd (GL) requirements, without certificate (non-essential duty only)	NA	NA	NA	M	M	M	M	M	M	M	M	M	P
Mounting arrangements													
007 IM 3001 flange mounted, IEC flange, from IM 1001 (B5 from B3).	NA	NA	NA	NA	NA	NA	NA	M	M	NA	NA	NA	NA
008 IM 2101 foot/flange mounted, IEC flange, from IM 1001 (B34 from B3).	NA	NA	NA	M	M	M	M	M	NA	NA	NA	NA	NA
009 IM 2001 foot/flange mounted, IEC flange, from IM 1001 (B35 from B3).	NA	NA	NA	M	M	M	M	M	M	M	M	M	M
047 IM 3601 flange mounted, IEC flange, from IM 3001 (B14 from B5).	NA	NA	NA	M	M	M	M	M	NA	NA	NA	NA	NA
048 IM 3001 flange mounted, IEC flange, from IM 3601 (B5 from B14).	NA	NA	M	M	M	M	M	NA	NA	NA	NA	NA	NA
066 Modified for specified mounting position differing from IM B3 (1001), IM B5 (3001), B14 (3601), IM B35 (2001) & IM B34 (2101)	M	M	M	M	M	M	M	M	M	M	M	M	M
078 (IM 3601) Flange mounted, DIN C-flange.	NA	NA	NA	R	R	NA	NA	NA	NA	NA	NA	NA	NA
116 Special flange.	R	R	NA	R	R	NA	NA	NA	NA	NA	NA	NA	NA
200 Flange ring holder.	NA	NA	NA	M	M	M	M	NA	NA	NA	NA	NA	NA
218 Flange ring FT 85.	NA	NA	NA	M	NA	NA	NA	NA	NA	NA	NA	NA	NA
219 Flange ring FT 100.	NA	NA	NA	M	NA	NA	NA	NA	NA	NA	NA	NA	NA
220 Flange ring FF 100.	NA	NA	NA	M	NA	NA	NA	NA	NA	NA	NA	NA	NA
223 Flange ring FF 115.	NA	NA	NA	M	NA	NA	NA	NA	NA	NA	NA	NA	NA
224 Flange ring FT 115.	NA	NA	NA	M	M	M	NA	NA	NA	NA	NA	NA	NA
226 Flange ring FF 130.	NA	NA	NA	M	M	M	NA	NA	NA	NA	NA	NA	NA
227 Flange ring FT 130.	NA	NA	NA	M	M	M	NA	NA	NA	NA	NA	NA	NA
229 Flange FT 130.	NA	NA	NA	NA	M	M	NA	NA	NA	NA	NA	NA	NA
233 Flange ring FF 165.	NA	NA	NA	M	M	M	NA	NA	NA	NA	NA	NA	NA
234 Flange ring FT 165.	NA	NA	NA	M	M	M	NA	NA	NA	NA	NA	NA	NA
235 Flange FF 165.	NA	NA	NA	M	NA	NA	NA	NA	NA	NA	NA	NA	NA
236 Flange FT 165.	NA	NA	NA	NA	NA	NA	M	NA	NA	NA	NA	NA	NA
243 Flange ring FF 215.	NA	NA	NA	NA	M	M	M	NA	NA	NA	NA	NA	NA
244 Flange ring FT 215.	NA	NA	NA	NA	M	M	M	NA	NA	NA	NA	NA	NA
245 Flange FF 215.	NA	NA	NA	NA	M	M	NA	NA	NA	NA	NA	NA	NA
253 Flange ring FF 265.	NA	NA	NA	NA	NA	NA	M	NA	NA	NA	NA	NA	NA
254 Flange ring FT 265.	NA	NA	NA	NA	NA	NA	M	NA	NA	NA	NA	NA	NA
255 Flange FF 265.	NA	NA	NA	NA	NA	NA	M	NA	NA	NA	NA	NA	NA
260 Flange FT 115.	NA	NA	NA	M	NA	NA	NA	NA	NA	NA	NA	NA	NA
Painting													
114 Special paint color, standard grade	NA	NA	NA	M	M	M	M	M	M	M	M	M	M
168 Primer paint only.	NA	NA	NA	P	P	P	P	NA	NA	NA	NA	NA	NA
179 Special paint specification.	R	R	R	R	R	R	R	R	R	R	R	R	R
Protection													
005 Protective roof, vertical motor, shaft down.	NA	NA	NA	M	M	M	M	M	M	M	M	M	M
072 Radial seal at D-end. Not possible for 2-pole , 280 and 315 frames	P	NA	NA	M	M	M	M	M	M	M	M	M	M
074 Degree of protection IP55.	NA	NA	NA	NA	NA	NA	NA	S	S	S	S	S	S
158 Degree of protection IP65.	NA	NA	NA	P	P	P	P	M	M	M	M	M	M
211 Weather protected, IP xx W	NA	P	P	M	M	M	M	M	M	M	M	M	M
403 Degree of protection IP56.	M	M	M	M	M	M	M	M	M	M	M	M	M
404 Degree of protection IP56, without fan and fan cover.	NA	NA	NA	P	P	P	P	NA	NA	NA	NA	NA	NA
784 Gamma-seal at D-end.	NA	NA	NA	M	M	M	M	M	M	M	M	M	M
Rating & instruction plates													
002 Restamping voltage, frequency and output, continuous duty.	NA	NA	NA	M	M	M	M	M	M	M	M	M	M
003 Individual serial number.	NA	NA	NA	S	S	S	S	S	S	S	S	S	S
004 Additional text on std rating plate (max 12 digits on free text line).	NA	NA	NA	M	M	M	M	M	M	M	M	M	M
095 Restamping output (maintained voltage, frequency), intermittent duty.	NA	NA	NA	M	M	M	M	M	M	M	M	M	M
098 Stainless rating plate.	NA	NA	NA	M	M	M	M	M	M	M	M	M	M
S:	Included as standard												
P:	New manufacture only												
M:	On modification of a stocked motor; or on new manufacture, the number per order may be limited												
R:	On request												
NA:	Not applicable												

Code/ Variant, M3AA	Frame size												
	63	71	80	90	100	112	132	160	180	200	225	250	280
135 Mounting of additional identification plate, stainless.	NA	NA	NA	M	M	M	M	M	M	M	M	M	R
138 Mounting of additional identification plate, aluminium.	M	M	M	M	M	M	M	M	M	M	M	M	M
139 Additional identification plate delivered loose.	NA	NA	NA	M	M	M	M	M	M	M	M	M	M
159 Additional plate with text "Made in"	NA	NA	NA	P	P	P	P	M	M	M	M	M	M
160 Additional rating plate affixed.	NA	NA	NA	M	M	M	M	M	M	M	M	M	M
161 Additional rating plate delivered loose.	M	M	M	M	M	M	M	M	M	M	M	M	M
162 Rating plate fixed to stator.	S	S	S	S	S	S	S	S	S	S	S	S	S
163 Frequency converter rating plate. Rating data according to quotation.	NA	NA	NA	M	M	M	M	M	M	M	M	M	M
198 Aluminum rating plate.	S	S	S	S	S	S	NA	S	S	S	S	S	S
333 Not for use in the USA	NA	NA	NA	M	M	M	M	M	M	M	M	M	M
Shaft & rotor													
069 Two shaft extensions as per basic catalogue.	NA	NA	NA	P	P	P	P	P	P	P	P	P	P
070 Special shaft extension at D-End, standard shaft material	NA	NA	NA	P	P	R	R	R	R	R	R	R	R
131 Motor delivered with half key (key not exceeding shaft diameter)	NA	NA	NA	M	M	M	M	M	M	M	M	M	M
155 Cylindrical shaft extension, D-end, without key-way.	NA	NA	NA	NA	NA	R	R	NA	NA	NA	NA	NA	NA
164 Shaft extension with closed keyway	NA	NA	NA	NA	NA	NA	NA	S	S	S	S	S	S
165 Shaft extension with open keyway	NA	NA	NA	P	P	P	P	P	P	P	P	P	P
410 Shaft material stainless steel	NA	NA	NA	P	P	R	R	R	R	R	R	R	R
600 Special shaft extension at N-end, standard shaft material.	NA	NA	NA	P	P	P	P	R	R	R	R	R	R
Standards and Regulations													
010 Fulfilling CSA Safety Certificate.	NA	NA	NA	P	P	P	P	M	M	M	M	M	M
152 Classified shaft material.	NA	NA	NA	NA	NA	NA	NA	R	R	R	R	R	R
154 Fulfilling requirements of specified classification society (certificate).	R	R	R	R	R	R	R	NA	NA	NA	NA	NA	NA
242 Fulfilling CSA Energy Efficiency Verification IE2 (code 010 included)	NA	NA	NA	NA	NA	NA	NA	P	P	P	P	P	NA
408 Fulfilling EISA Subtype II efficiency requirements, CC031A.	NA	NA	NA	R	R	NA	NA	P	P	P	P	P	P
497 Fulfilling Russian Maritime Register of Shipping (RS) requirements, without certificate.	NA	NA	NA	NA	NA	NA	NA	M	M	M	M	M	M
500 Fulfilling Korean MEPS efficiency regulations	NA	NA	NA	NA	NA	NA	NA	R	R	R	R	R	R
540 China energy label	NA	NA	NA	NA	NA	NA	NA	M	M	M	M	M	M
542 NBR design	P	P	NA	P	P	P	P	P	P	P	P	P	P
543 Australian MEPS	NA	NA	P	P	P	P	P	P	P	P	P	P	NA
756 EDF - UTO Specification for nuclear motor	NA	NA	NA	NA	NA	R	R	NA	NA	NA	NA	NA	NA
778 GOST Export/Import Certificate (Russia).	NA	NA	NA	P	P	P	P	M	M	M	M	M	M
779 SASO Export/Import Certificate (Saudi Arabia)	NA	NA	NA	NA	NA	NA	NA	M	M	M	M	M	M
Stator winding temperature sensors													
120 KTY 84-130 (1 per phase) in stator winding.	NA	NA	NA	NA	NA	NA	NA	R	R	R	R	R	R
121 Bimetal detectors, break type (NCC), (3 in series), 130 °C, in stator winding	NA	NA	NA	M	M	M	M	M	M	M	M	M	M
122 Bimetal detectors, break type (NCC), (3 in series), 150 °C, in stator winding	NA	NA	NA	M	M	M	M	M	M	M	M	M	M
123 Bimetal detectors, break type (NCC), (3 in series), 170 °C, in stator winding	NA	NA	NA	M	M	M	M	M	M	M	M	M	M
124 Bimetal detectors, break type (NCC), (3 in series), 140 °C, in stator winding	NA	NA	NA	NA	NA	NA	NA	M	M	M	M	M	M
125 Bimetal detectors, break type (NCC), (2x3 in series), 150 °C, in stator winding	NA	NA	NA	M	M	M	M	M	M	M	M	M	M
127 Bimetal detectors, break type (NCC), (3 in series, 130 °C & 3 in series, 150 °C), in stator winding	NA	NA	NA	M	M	M	M	M	M	M	M	M	M
321 Bimetal detectors, closing type (NO), (3 in parallel), 130°C, in stator winding.	NA	NA	NA	M	M	M	M	NA	NA	NA	NA	NA	NA
322 Bimetal detectors, closing type (NO), (3 in parallel), 150°C, in stator winding.	NA	NA	NA	M	M	M	M	NA	NA	NA	NA	NA	NA
323 Bimetal detectors, closing type (NO), (3 in parallel), 170°C, in stator winding.	R	R	R	NA	NA	R	R	NA	NA	NA	NA	NA	NA
435 PTC - thermistors (3 in series), 130 °C, in stator winding	NA	NA	NA	M	M	M	M	M	M	M	M	M	M
436 PTC - thermistors (3 in series), 150 °C, in stator winding	NA	NA	NA	M	M	M	M	S	S	S	S	S	S
437 PTC - thermistors (3 in series), 170 °C, in stator winding	NA	NA	NA	M	M	M	M	M	M	M	M	M	M
439 PTC - thermistors (2 × 3 in series), 150 °C, in stator winding	NA	NA	NA	M	M	M	M	M	M	M	M	M	M
440 PTC - thermistors (3 in series, 110°C & 3 in series, 130°C), in stator winding.	NA	NA	NA	P	P	P	P	NA	NA	NA	NA	NA	NA
441 PTC - thermistors (3 in series, 130 °C & 3 in series, 150 °C), in stator winding	NA	NA	NA	M	M	M	M	M	M	M	M	M	M
442 PTC - thermistors (3 in series, 150 °C & 3 in series, 170 °C), in stator winding	NA	NA	NA	P	P	M	M	M	M	M	M	M	M
445 Pt100 2-wire in stator winding, 1 per phase	NA	NA	NA	M	M	M	M	M	M	M	M	M	M

S: Included as standard
P: New manufacture only
M: On modification of a stocked motor; or on new manufacture, the number per order may be limited
R: On request
NA: Not applicable

Code/ Variant, M3AA	Frame size												
	63	71	80	90	100	112	132	160	180	200	225	250	280
446 Pt100 2-wire in stator winding, 2 per phase	NA	R	R	R	R	R	R	M	M	M	M	M	M
Terminal box													
015 Motor supplied in D connection.	NA	NA	NA	M	M	M	M	M	M	M	M	M	M
016 9 terminals in terminal box	NA	NA	NA	P	P	P	P	NA	NA	NA	NA	NA	NA
017 Motor supplied in Y connection.	NA	NA	NA	P	P	NA	NA	M	M	M	M	M	M
019 Larger than standard terminal box.	NA	NA	NA	NA	NA	NA	NA	NA	NA	M	M	M	M
021 Terminal box LHS (seen from D-end).	NA	NA	NA	NA	NA	NA	NA	NA	NA	P	P	P	P
022 Cable entry LHS (seen from D-end).	NA	NA	NA	NA	NA	NA	NA	S	S	NA	NA	NA	NA
230 Standard metal cable glands.	M	M	M	P	P	P	P	M	M	M	M	M	M
375 Standard plastic cable gland	NA	NA	NA	M	M	M	M	NA	NA	NA	NA	NA	NA
376 Two standard plastic cable glands	NA	NA	NA	M	M	M	M	NA	NA	NA	NA	NA	NA
418 Separate terminal box for auxiliaries, standard material.	NA	NA	NA	NA	R	R	R	M	M	M	M	M	M
465 Terminal box on top.	NA	NA	NA	NA	NA	NA	NA	S	S	S	S	S	S
467 Lower than standard terminal box and rubber extended cable. Cable length 2 m	NA	NA	NA	NA	NA	NA	NA	P	P	P	P	P	P
729 Aluminum non-drilled flange for cable glands	NA	NA	NA	NA	NA	NA	NA	NA	NA	M	M	M	M
731 Two standard metal cable glands.	NA	M	M	P	P	P	P	M	M	M	M	M	M
738 Prepared for metric cable glands.	NA	NA	NA	NA	NA	NA	NA	S	S	S	S	S	S
740 Prepared for PG cable glands.	NA	NA	NA	NA	NA	M	M	M	M	M	M	M	M
743 Painted non-drilled flange in steel for cable glands	NA	NA	NA	NA	NA	NA	NA	NA	NA	S	S	S	S
Testing													
140 Test confirmation.	NA	NA	NA	NA	NA	NA	NA	M	M	M	M	M	M
145 Type test report from a catalogue motor, 400V 50Hz.	P	M	M	M	P	P	P	M	M	M	M	M	M
146 Type test with report for one motor from specific delivery batch.	NA	NA	NA	M	M	M	M	M	M	M	M	M	M
147 Type test with report for motor from specific delivery batch, customer witnessed.	NA	NA	NA	M	M	M	M	M	M	M	M	M	M
148 Routine test report.	P	P	P	P	P	P	P	M	M	M	M	M	M
149 Test according to separate test specification.	R	R	R	R	R	R	R	R	R	R	R	R	R
153 Reduced test for classification society.	P	P	P	M	M	M	M	M	M	M	M	M	M
221 Type test and multi-point load test with report for one motor from specific delivery batch.	P	P	P	M	M	M	M	M	M	M	M	M	M
222 Torque/speed curve, type test and multi-point load test with report for one motor from specific delivery batch.	P	P	P	P	P	M	M	M	M	M	M	M	M
760 Vibration level test	P	P	P	P	P	M	M	M	M	M	M	M	M
762 Noise level test for one motor from specific delivery batch.	P	P	P	P	P	P	P	M	M	M	M	M	M
Variable speed drives													
181 Rating plate with ABB standard loadability values for VSD operation. Other auxiliaries for VSD operation to be selected as necessary.	NA	NA	NA	R	R	R	R	NA	NA	NA	NA	NA	NA
470 Prepared for hollow shaft pulse tacho (L&L equivalent).	NA	NA	NA	R	R	R	R	M	M	M	M	M	M
472 1024 pulse tacho (L&L 861007455-1024).	NA	NA	NA	R	R	R	R	M	M	M	M	M	M
473 2048 pulse tacho (L&L 861007455-2048).	NA	NA	NA	R	R	R	R	M	M	M	M	M	M
474 Separate motor cooling (axial fan, N-end) and prepared for hollow shaft tacho (L&L equivalent)	NA	NA	NA	R	R	R	R	M	M	M	M	M	M
476 Separate motor cooling (axial fan, N-end) and 1024 pulse tacho (L&L 861007455-1024)	NA	NA	NA	R	R	R	R	M	M	M	M	M	M
477 Separate motor cooling (axial fan, N-end) and 2048 pulse tacho (L&L 861007455-2048)	NA	NA	NA	R	R	R	R	M	M	M	M	M	M
479 Mounting of other type of pulse tacho with shaft extension, tacho not included.	NA	NA	NA	NA	NA	NA	NA	R	R	R	R	R	R
570 Prepared for hollow shaft pulse tacho (L&L 503).	NA	NA	NA	NA	NA	R	R	M	M	M	M	M	M
572 1024 pulse tacho (L&L 503).	NA	NA	NA	NA	NA	R	R	M	M	M	M	M	M
573 2048 pulse tacho (L&L 503).	NA	NA	NA	NA	NA	P	P	M	M	M	M	M	M
574 Separate motor cooling (fan axial, N-end) and prepared for hollow shaft tacho (L&L 503).	NA	NA	NA	NA	NA	NA	NA	M	M	M	M	M	M
576 Separate motor cooling (fan axial, N-end) and 1024 pulse tacho (L&L 503).	NA	NA	NA	NA	NA	NA	NA	M	M	M	M	M	M
577 Separate motor cooling (fan axial, N-end) and 2048 pulse tacho (L&L 503).	NA	NA	NA	NA	NA	NA	NA	M	M	M	M	M	M
580 Separate motor cooling, IP44, 400 V, 50Hz (axial fan, N-end) and 1024 pulse tacho (L&L 503)	NA	NA	NA	NA	NA	P	P	M	M	M	M	M	M
581 Separate motor cooling, IP44, 400V, 50Hz (fan axial, N-end) and 2048 pulse tacho (L&L 503).	NA	NA	NA	NA	NA	P	P	M	M	M	M	M	M

S: Included as standard
P: New manufacture only
M: On modification of a stocked motor; or on new manufacture, the number per order may be limited
R: On request
NA: Not applicable

Code/ Variant, M3AA	Frame size												
	63	71	80	90	100	112	132	160	180	200	225	250	280
661 1024 Pulse tachometer mounted, Hohner series 59, 11-30V	NA	NA	NA	P	P	P	P	NA	NA	NA	NA	NA	NA
701 Insulated bearing at N-end.	NA	NA	NA	NA	NA	NA	NA	M	M	M	M	M	M
704 EMC cable gland.	NA	NA	NA	M	M	M	M	M	M	M	M	M	M

Y/D starting

023 6 terminals (for Y/D start, single speed), in terminal box.	NA	NA	NA	S	S	S	S	S	S	S	S	S	S
117 Terminals for Y/D start at both speeds (two speed windings).	NA	NA	NA	P	P	P	P	NA	NA	NA	NA	NA	R
118 Terminals for Y/D start at high speed (two speed windings).	NA	NA	NA	P	P	P	P	NA	NA	NA	NA	NA	NA

- S: Included as standard
- P: New manufacture only
- M: On modification of a stocked motor; or on new manufacture, the number per order may be limited
- R: On request
- NA: Not applicable

Mechanical design

Motor frame and drain holes

Motor frame

The motor frame is made of aluminum alloy. Frame sizes 63 to 180 have aluminum feet and sizes 200 to 280 have cast iron feet.

The bearing end shields of sizes 63 to 132 are made of aluminum, and those of 160 to 280 are made of cast iron.

Drain holes

Motors that will be operated in very humid or wet environments and especially under intermittent duty should be provided with drain holes. The IM designation, such as IM 3031, determines the intended mounting arrangement for the motor.

Motors are provided with closable plastic plugs in the drain holes. The plugs on delivery, when mounting the motors, ensure that the drainholes face downwards. In the case of vertical mounting, the upper plug must be hammered home completely. In very dusty environments both plugs should be hammered home.

Motors are supplied with drain holes both at the D-end and N-end.

When mounting arrangement differs from foot mounted IM B3, please use variant code 066 when ordering. See variant codes 065, 066 and 076 under the heading "Drain holes".

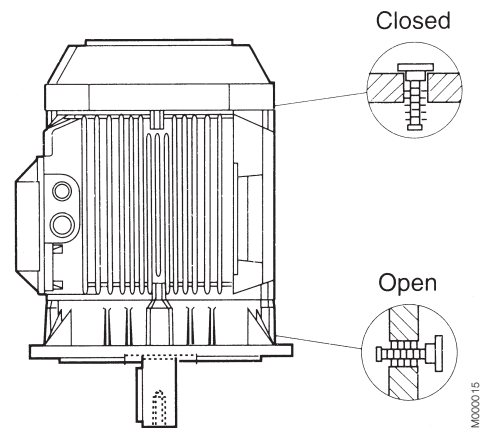
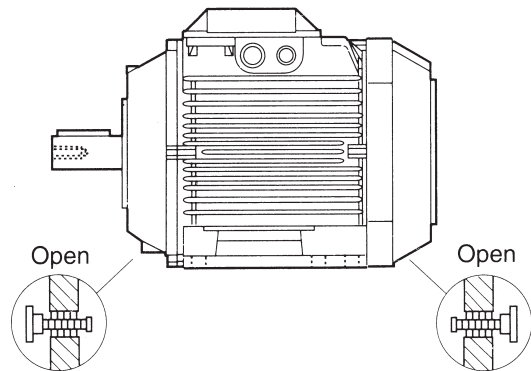

Bearings

The motors are provided with bearings according to the tables below.

Greater axial forces can be tolerated if the motors are provided with angular contact ball bearings.

Standard design: deep groove ball bearings

Motor size	Foot- and flange-mounted motor	
	D-end	N-end
63	6202-2Z/C3	6201-2Z/C3
71	6203-2Z/C3	6202-2Z/C3
80	6204-2Z/C3	6203-2Z/C3
90	6205-2Z/C3	6204-2Z/C3
100	6306-2Z/C3	6205-2Z/C3
112	6306-2Z/C3	6205-2Z/C3
132 ¹⁾	6208-2Z/C3	6206-2Z/C3
132 ²⁾	6308-2Z/C3	6206-2Z/C3
160	6309-2Z/C3	6209-2Z/C3
180	6310-2Z/C3	6209-2Z/C3
200	6312-2Z/C3	6210-2Z/C3
225	6313-2Z/C3	6212-2Z/C3
250	6315-2Z/C3	6213-2Z/C3
280 2 pole	6315/C3	6213/C3
280 4-8 pole	6316/C3	6213/C3

¹⁾ all types except ²⁾

²⁾ SM_

Note that in such cases the axial force must only operate in one direction.

Motor versions with roller bearings tolerate greater radial forces.

Alternative design with roller bearings

It is recommended to use roller bearings in belt drives for motor sizes 160 to 280.

See variant code 037 under the heading "Bearings and lubrication".

Motor size	Foot- and flange-mounted motor	
	D-end	N-end
63	-	6201-2Z/C3
71	-	6202-2Z/C3
80	-	6203-2Z/C3
90	NU 205	6204-2Z/C3
100	NU 306	6205-2Z/C3
112	NU 306	6205-2Z/C3
132 ¹⁾	NU 208	6206-2Z/C3
132 ²⁾	NU 308	6206-2Z/C3
160	NU 309 ECP	6209-2Z/C3
180	NU 310 ECP	6209-2Z/C3
200	NU 312 ECP	6210-2Z/C3
225	NU 313 ECP	6212-2Z/C3
250	NU 315 ECP	6213-2Z/C3
280 2 pole	NU 315 ECP	6213/C3
280 4-8 pole	NU 316 ECP	6213/C3

¹⁾ all types except ²⁾

²⁾ SM_

Alternative design: angular contact ball bearings

See variant codes 058 and 059 under the heading "Bearings and lubrication".

Motor size	D-end 058	N-end 059
63	-	-
71	-	-
80	-	-
90	7205 B	7204 B
100	7306 B	7205 B
112	7306 B	7205 B
132 ¹⁾	7208 B	7206 B
132 ²⁾	7308 B	7206 B
160	7309 BEP	7209 BEP
180	7310 BEP	7209 BEP
200	7312 BEP	7210 BEP
225	7313 BEP	7212 BEP
250	7315 BEP	7213 BEP
280 2 pole	7315 BEP	7213 BEP
280 4-8 pole	7316 BEP	7213 BEP

¹⁾ all types except ²⁾

²⁾ SM_

Transport locking

Motors provided with roller bearings or angular contact ball bearings are fitted with a transport lock to prevent damage to the bearings, due to vibration, during transport.

Axially locked bearings

The table below shows which of the motor's bearings are axially locked in the bearing seat. In motor size 63 the locking is done by an internal retaining ring, in motor sizes 71 to 280 by an inner bearing cover.

Motor size	Foot-mounted motors	Flange-mounted motors	
		Large flange	Small flange
63	On request at D-end	On request at D-end	On request at D-end
71-132	D-end ¹⁾	D-end ¹⁾	D-end ¹⁾
160-280	D-end	D-end	-

¹⁾ A spring-washer at the N-end presses the rotor toward the D-end.

Bearing seals

Motor size	Number of poles	Standard design, axial seal		Alternative design Radial seal (Din3760) Variant code 073
		D-end	N-end	
71	2-12	V-16A	Labyrinth seal	17×28×7
80	2-12	V-20A	Labyrinth seal	20×40×7
90	2-12	V-25A	Labyrinth seal	25×42×7
100	2-12	V-30A	Labyrinth seal	30×47×7
112	2-12	V-30A	Labyrinth seal	30×47×7
132	2-12	V-40A	Labyrinth seal	40×62×7
160	2-12	V-45A	V-45A	45×65×8
180	2-12	V-50A	V-45A	50×72×8
200	2-12	V-60A	V-50A	60×80×8
225	2-12	V-65A	V-60A	65×85×8
250	2-12	V-75A	V-65A	75×95×8

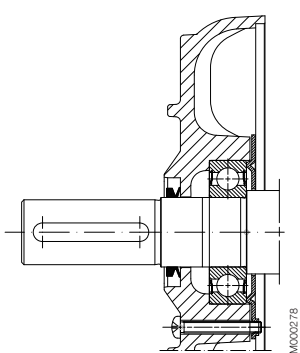

Motor sizes 71 - 132

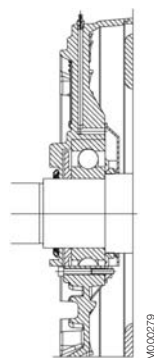

Motor sizes 160 - 250

Bearing life and lubrication

Bearing life

The nominal life is defined as the number of hours that are attained or exceeded by 90 percent of identical bearings, in a large test series, under certain specified conditions. 50 percent of the bearings attain a life of as much as 5 times this figure.

The life of bearings is dependent on various factors such as bearing load, motor speed, operating temperature and the purity of the grease. The permissible radial and axial loading for different motor sizes is shown in the table on the following pages.

The table is valid for 50 Hz. For 60 Hz and/or some other bearing life than specified in the table the values are changed according to the table on the right.

The table values assume the occurrence of only radial or axial forces. In the case of simultaneous radial and axial forces information can be supplied on request. It is assumed that the radial force is applied at the end of the motor shaft.

Permissible force at changed bearing life or supply frequency

Bearing life in hours at		Permissible force, as percentage of value in tables
50 Hz	60 Hz	
25 000	21 000	100 % of value for 25.000 hours
40 000	33 000	100 % of value for 40.000 hours
63 000	52 000	86 % of value for 40.000 hours
80 000	67 000	80 % of value for 40.000 hours

Lubrication

The motors are delivered with bearing grease for use at normal temperatures in dry or humid environments. The motors are lubricated for ambient temperatures 40°C and in some cases even above 40°C, see table 1 next page.

Motor sizes 63 to 250 are provided with shielded bearings. As an option, motor sizes 90 to 250 are provided with grease nipples for regreasing, see variant code 041 under the heading "Bearings and lubrications".

Motor size 280 is provided with grease nipples for re-greasing as standard.

The lubrication interval L_1 , suitable for relubricated bearings, is defined as the number of operating hours after which 99 percent of the bearings are adequately lubricated.

Lubrication intervals and grease quantities are specified on a plate on the motor as well as in the manual supplied with the motor.

The grease lifetime L_{10} , suitable for permanent lubricated bearings, is defined as the number of operating hours after which 90 percent of the bearings are adequately lubricated. 50 percent of the bearings achieve two times this figure. Maximum lifetime, however, should be regarded as 40,000 hours.

In case of high ambient temperatures the shaft loads must be reduced compared to permissible loadings in the table, please contact ABB.

Lubrication intervals

ABB follows the L_1 -principle in defining lubrication interval. That means that 99 percent of the motors are sure to make the interval time. The lubrication intervals can also be calculated according to the L_{10} -principle, which are normally doubled compared to L_1 -values. Values available from ABB at request.

The table below gives lubrication intervals according to the L_1 -principle for different speeds. The values are valid for horizontal mounted motors (B3), with about 80°C bearing temperature and using good quality grease with lithium complex soap and with mineral or PAO-oil.

For more information, see ABB's Low Voltage Motors Manual.

Lubrication intervals for ball and roller bearings

Frame size	Amount of grease g	Amount of grease g					
		3600 r/min	3000 r/min	1800 r/min	1500 r/min	1000 r/min	500-750 r/min
Ball bearings: lubrication intervals in duty hours							
280	60	2000	3500	-	-	-	-
280	70	-	-	8000	10 500	14 000	17 000
Roller bearings: lubrication intervals in duty hours							
280	60	1000	1750	-	-	-	-
280	70	-	-	4000	5250	7000	8500

Grease lifetime

Ambient temperature and rated output

Motor	r/min	25 °C		40 °C		50 °C		60 °C		70 °C		80 °C	
		Basic	High	Basic	High	Basic	High	Basic	High	Basic	High	Basic	High
63	3000	40 000	40 000	40 000	40 000	40 000	40 000	31 000	31 000	17 000	17 000	9000	9000
	1500	40 000	40 000	40 000	40 000	40 000	40 000	33 000	33 000	18 000	18 000	9000	9000
	1000	40 000	40 000	40 000	40 000	40 000	40 000	33 000	33 000	18 000	18 000	9000	9000
	750	40 000	40 000	40 000	40 000	40 000	40 000	33 000	33 000	18 000	18 000	9000	9000
71	3000	40 000	40 000	40 000	40 000	40 000	40 000	27 000	27 000	15 000	15 000	8000	8000
	1500	40 000	40 000	40 000	40 000	40 000	40 000	33 000	33 000	18 000	18 000	9000	9000
	1000	40 000	40 000	40 000	40 000	40 000	40 000	33 000	33 000	18 000	18 000	9000	9000
	750	40 000	40 000	40 000	40 000	40 000	40 000	33 000	33 000	18 000	18 000	9000	9000
80	3000	40 000	40 000	40 000	40 000	39 000	39 000	23 000	23 000	13 000	13 000	7000	7000
	1500	40 000	40 000	40 000	40 000	40 000	40 000	33 000	33 000	18 000	18 000	9000	9000
	1000	40 000	40 000	40 000	40 000	40 000	40 000	33 000	33 000	18 000	18 000	9000	9000
	750	40 000	40 000	40 000	40 000	40 000	40 000	33 000	33 000	18 000	18 000	9000	9000
90	3000	40 000	40 000	40 000	40 000	33 000	33 000	20 000	20 000	11 000	11 000	6000	6000
	1500	40 000	40 000	40 000	40 000	40 000	40 000	33 000	33 000	18 000	18 000	9000	9000
	1000	40 000	40 000	40 000	40 000	40 000	40 000	33 000	33 000	18 000	18 000	9000	9000
	750	40 000	40 000	40 000	40 000	40 000	40 000	33 000	33 000	18 000	18 000	9000	9000
100	3000	40 000	40 000	39 000	39 000	25 000	25 000	15 000	15 000	8000	8000	4000	4000
	1500	40 000	40 000	40 000	40 000	40 000	40 000	30 000	30 000	17 000	17 000	9000	9000
	1000	40 000	40 000	40 000	40 000	40 000	40 000	33 000	33 000	18 000	18 000	9000	9000
	750	40 000	40 000	40 000	40 000	40 000	40 000	33 000	33 000	18 000	18 000	9000	9000
112	3000	40 000	40 000	39 000	39 000	25 000	25 000	15 000	15 000	8000	8000	4000	4000
	1500	40 000	40 000	40 000	40 000	40 000	40 000	30 000	30 000	17 000	17 000	9000	9000
	1000	40 000	40 000	40 000	40 000	40 000	40 000	33 000	33 000	18 000	18 000	9000	9000
	750	40 000	40 000	40 000	40 000	40 000	40 000	33 000	33 000	18 000	18 000	9000	9000
132 ¹⁾	3000	40 000	40 000	33 000	33 000	21 000	21 000	13 000	13 000	7000	7000	4000	4000
	1500	40 000	40 000	40 000	40 000	40 000	40 000	26 000	26 000	14 000	14 000	7000	7000
	1000	40 000	40 000	40 000	40 000	40 000	40 000	33 000	33 000	18 000	18 000	9000	9000
	750	40 000	40 000	40 000	40 000	40 000	40 000	33 000	33 000	18 000	18 000	9000	9000

¹⁾ all types except ²⁾

²⁾ SM_

In vertically mounted motors, the grease lifetime is half the figures above.

For applications corresponding to the empty cells in the table, please contact ABB. These applications can imply reduced lifetime for bearings and winding. Motors with roller bearings (optional) have considerably shorter grease life. For continuous operation regreasing nipples should be considered.

Table 1: Grease lifetime L_{10} in deep groove ball bearings of type 2Z in horizontally mounted motors in continuous running duty.
Table continues on next page

Grease lifetime

Ambient temperature and rated output

Motor	r/min	25 °C		40 °C		50 °C		60 °C		70 °C		80 °C	
		Basic	High	Basic	High	Basic	High	Basic	High	Basic	High	Basic	High
132 ²⁾	3000	40 000	40 000	31 000	31 000	20 000	20 000	12 000	12 000	6000	6000	3000	3000
	1500	40 000	40 000	40 000	40 000	40 000	40 000	24 000	24 000	13 000	13 000	7000	7000
	1000	40 000	40 000	40 000	40 000	40 000	40 000	33 000	33 000	18 000	18 000	9000	9000
	750	40 000	40 000	40 000	40 000	40 000	40 000	33 000	33 000	18 000	18 000	9000	9000
160	3000	40 000	40 000	40 000	36 000	40 000	19 000	26 000	9000	14 000	5000	8000	2000
	1500	40 000	40 000	40 000	40 000	40 000	40 000	40 000	38 000	40 000	20 000	37000	10 000
	1000	40 000	40 000	40 000	40 000	40 000	40 000	40 000	40 000	40 000	24 000	40 000	12 000
	750	40 000		40 000		40 000		40 000		40 000		40 000	
180	3000	38 000	38 000	38 000	38 000	38 000	38 000	38 000	23 000	23 000	12 000	13 000	7000
	1500	40 000	40 000	40 000	40 000	40 000	24 000	40 000	12 000	26 000	6000	13 000	3000
	1000	40 000	40 000	40 000	40 000	40 000	40 000	40 000	40 000	40 000	24 000	29 000	12 000
	750	40 000		40 000		40 000		40 000		37000		21 000	
200	3000	27 000	27 000	27 000	27 000	27 000	18 000	24 000	10 000	14 000	5000	8000	3000
	1500	40 000	40 000	40 000	40 000	40 000	40 000	40 000	32000	40 000	18 000	30 000	10 000
	1000	40 000	40 000	40 000	40 000	40 000	40 000	40 000	40 000	40 000	30 000	38 000	17 000
	750	40 000		40 000		40 000		40 000		40 000		40 000	
225	3000	23 000	23 000	23 000	18 000	23 000	10 000	20 000	6000	12 000	3000	7000	1000
	1500	40 000	40 000	40 000	40 000	40 000	23 000	40 000	12 000	40 000	6000	25 000	3000
	1000	40 000	40 000	40 000	40 000	40 000	40 000	40 000	40 000	40 000	40 000	40 000	27 000
	750	40 000		40 000		40 000		40 000		40 000		40 000	
250	3000	16 000	16 000	16 000	13 000	16 000	7000	12 000	4000	7000	2000	4000	1000
	1500	40 000	40 000	40 000	39 000	40 000	21 000	40 000	11 000	33 000	6000	19 000	3000
	1000	40 000	40 000	40 000	40 000	40 000	40 000	40 000	40 000	40 000	25 000	36 000	13 000
	750	40 000		40 000		40 000		40 000		40 000		40 000	

²⁾ SM_

In vertically mounted motors, the grease lifetime is half the figures above.

For applications corresponding to the empty cells in the table, please contact ABB. These applications can imply reduced lifetime for bearings and winding.

Motors with roller bearings (optional) have considerably shorter grease life. For continuous operation regreasing nipples should be considered.

Table 1: Grease lifetime L_{10} in deep groove ball bearings of type 2Z in horizontally mounted motors in continuous running duty.

Radial forces

Pulley diameter

When the desired bearing life has been determined the minimum permissible pulley diameter can be calculated with F_R , according to the formula:

$$D = \frac{1.9 \cdot 10^7 \cdot K \cdot P}{n \cdot F_R}$$

Where:

D:	pulley diameter, mm
P:	power requirement, kW
n:	motor speed, r/min.
K:	belt tension factor, dependent on belt type and type of duty. A common value for V-belts is 2.5
F_R:	permissible radial force

Permissible loading on shaft

The tables give the permissible radial force in Newtons, assuming zero axial force, ambient temperature of 25°C.

Permissible loads of simultaneous radial and axial forces will be supplied on request.

The bearing life, L_{10} , is calculated according to SKF's theory on bearing life L_{10aah} , which also takes the purity of the grease into consideration. An adequate lubrication is a necessary prerequisite for the table at right.

If the radial force is applied between points X_0 and X_{max} , the permissible force F_R can be calculated from the following formula:

$$F_R = F_{X_0} - \frac{X}{E} (F_{X_0} - F_{X_{max}})$$

Where:

E:	length of the shaft extension in the standard version
-----------	---

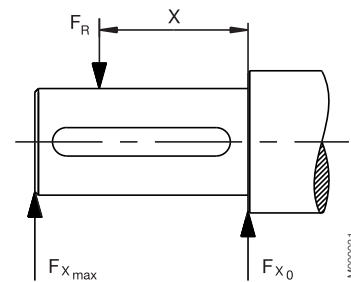

Permissible radial forces

Motor sizes 63 to 132

Motor size	No. of poles	Length of shaft extension E (mm)	Ball bearings Basic design with deep groove ball bearings			
			25 000 hrs		40 000 hrs	
			F_{x0} (N)	F_{xmax} (N)	F_{x0} (N)	F_{xmax} (N)
63	2-8	23	490	400	490	400
71	2-8	30	680	570	680	570
80	2	40	630	750	930	750
80	4-8	40	930	750	930	750
90	2-8	50	1010	810	1010	810
100	2-8	60	2280	1800	2280	1800
112	2-8	60	2280	1800	2280	1800
132 ¹⁾	2-8	80	2120	1610	2120	1610
132 ²⁾	2-8	80	2600	2100	2600	2100

¹⁾ 62-series bearings

²⁾ 63-series bearings

Motor sizes 160 to 280

Motor size	No. of poles	Length of shaft extension E (mm)	Ball bearings Basic design with deep groove ball bearings				Roller bearings Alternative design with roller bearings			
			20 000 hrs		40 000 hrs		20 000 hrs		40 000 hrs	
			F_{x0} (N)	F_{xmax} (N)	F_{x0} (N)	F_{xmax} (N)	F_{x0} (N)	F_{xmax} (N)	F_{x0} (N)	F_{xmax} (N)
160	2	110	4760	3860	4100	3320	6580	4300	5620	4300
	4	110	5180	4200	4380	3545	7340	4300	6180	4300
	6	110	5160	4180	4360	3540	7780	4300	6500	4300
	8	110	6280	4300	5320	4300	8860	4300	7440	4300
180	2	110	6060	4960	5280 ¹⁾	4305 ¹⁾	7600	5500	6560	5500
	4	110	4800	3940	4020	3300	7280	5500	6140	5500
	6	110	6280	5140	5280	4380	8680	5500	7280	5500
	8	110	6960	5500	5880	4800	9440	5500	7920	5500
200	2	110	7800	6500	6760 ²⁾	5640 ²⁾	10 360	8640	8880	7400
	4	110	8400	7020	7180	5980	11 560	9550	9800	8180
	6	110	8960	7480	7600	6340	12 480	9550	10 520	8780
	8	110	10480	8740	8940	7400	14 100	9550	11 920	9550
225	2	110	8520	7180	7360 ³⁾	6200 ³⁾	12 320	10 380	10 560	8900
	4	140	8380	6780	7200	5820	13 380	10 250	11 320	9160
	6	140	10 960	8860	9360	7560	15 860	10 250	13 420	10 250
	8	140	12 100	9780	10 340	8360	17 220	10 250	14 580	10 250
250	2	140	10 480 ⁴⁾	8500 ⁴⁾	9080 ⁴⁾	7360 ⁴⁾	16 220	10 900	13 960	10 900
	4	140	10 840	8780	9380	7600	18 020	13 800	15 320	13 800
	6	140	12 600	10 220	10 700	8680	20 240	13 800	17 140	13 800
	8	140	14 660	11 880	12 540	10 160	22 680	13 800	19 220	13 800
280	2	140	6780	5500	5680	4600	16 280	13 200	14 000	11 360
	4	140	8060	6540	6640	5380	19 480	15 780	16 540	13 400
	6	140	8980	7280	7360	5960	21 920	17 760	18 580	15 060
	8	140	9180	7460	7460	6060	22 240	18 020	18 860	15 300

¹⁾ The maximum lifetime of the grease is 38 000 h

²⁾ The maximum lifetime of the grease is 27 000 h

³⁾ The maximum lifetime of the grease is 23 000 h

⁴⁾ The maximum lifetime of the grease is 16 000 h

Axial forces

The following tables give the permissible axial forces in Newtons, assuming zero radial force, ambient temperature of 25°C. The values are based on normal conditions at 50 Hz with standard bearings and calculated bearing lives of 20 000 and 40 000 hours.

At 60 Hz the values are to be reduced by 10 percent.

For two-speed motors, the values are to be based on the higher speed. The permissible loads of simultaneous radial and axial forces will be supplied on request.

Given axial forces F_{AD} , assumes D-bearing locked by means of locking ring.

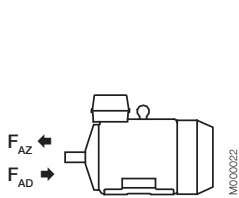

Mounting arrangement IM B3

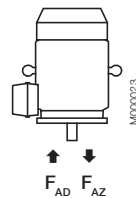

Mounting arrangement IM V1

Permissible axial forces, motor sizes 63 - 280

Motor size	Poles	Mounting arrangement IM B3, deep groove ball bearings				Mounting arrangement IM V1, deep groove ball bearings			
		20 000 hours		40 000 hours		20 000 hours		40 000 hours	
		F_{AD} (N)	F_{AZ} (N)	F_{AD} (N)	F_{AZ} (N)	F_{AD} (N)	F_{AZ} (N)	F_{AD} (N)	F_{AZ} (N)
63	2	480	125	420	105	495	115	440	95
	4	565	165	470	115	585	155	490	105
	6	580	190	490	145	600	180	550	115
	8	590	195	590	205				
71	2	625	325	515	215	640	315	530	200
	4	780	480	630	330	800	470	650	320
	6	890	590	710	410	925	570	745	390
	8	985	685	780	480	1020	665	815	455
80	2	810	470	650	315	845	450	690	290
	4	1015	675	810	470	1075	640	865	430
	6	1170	830	925	595	1225	795	980	550
	8	1300	960	1015	675	1350	925	1070	645
90	2	885	485	720	320	945	450	775	280
	4	1170	650	945	425	1245	600	1020	375
	6	1270	870	1005	605	1360	815	1095	550
	8	1410	1010	1110	710	1485	960	1185	660
100	2	1620	1120	1280	780	1710	1060	1370	715
	4	2065	1565	1615	1115	2180	1485	1735	1035
	6	2390	1890	1860	1360	2510	1815	1980	1285
	8	2660	2160	2065	1565	2780	2080	2185	1485
112 M, MB	2	1615	1115	1275	775	1725	1040	1385	700
	4	2060	1560	1610	1110	2210	1460	1110	1010
	6	2385	1885	1860	1360	2540	1785	2010	1260
	8	2655	2155	2060	1560	2790	2055	2195	1475

Permissible axial forces, motor sizes 63 - 280

Motor size	Poles	Mounting arrangement IM B3, deep groove ball bearings				Mounting arrangement IM V1, deep groove ball bearings			
		20 000 hours		40 000 hours		20 000 hours		40 000 hours	
		F _{AD} (N)	F _{AZ} (N)	F _{AD} (N)	F _{AZ} (N)	F _{AD} (N)	F _{AZ} (N)	F _{AD} (N)	F _{AZ} (N)
132 M, MA	4	2245	1645	1760	1160	2460	1505	1970	1015
	6	2595	1980	2025	1425	2815	1850	2245	1280
	8	2875	2270	2240	1640	3130	2115	2490	1470
132 MC	6	2580	1980	2010	1410	2885	1780	2315	1210
132 MBA	4	2235	1635	1750	1150	2495	1465	2010	980
132 S	6	2600	2000	2030	1435	2780	1885	2210	1315
	8	2885	2285	2245	1645	3100	2145	2460	1505
132 SB	2	1760	1160	1400	800	1910	1075	1540	705
132 SBB, SC	2	1760	1160	1395	795	1945	1045	1575	670
132 SMB, SMC	2	2210	1610	1740	1140	2435	1470	1950	985
	4	2840	2240	2205	1605	3150	2035	2515	1400
132 SMD	4	2830	2200	2230	1595	3195	1995	2560	1355
132 SME	2	2210	1610	1730	1130	2490	1425	2005	940
160	2	4160	4160	3425	3425	4560	3810	3860	3110
	4	4740	4740	3920	3920	5260	4310	4440	3490
	6	4840	4840	4000	4000	5400	4420	4540	3560
	8	5980	5980	4920	4920	6560	5580	5460	4480
180	2	5480	5480	4600 ¹⁾	4600 ¹⁾	5920	5115	5060 ¹⁾	4255 ¹⁾
	4	4360	4360	3540	3540	5080	3860	4240	3020
	6	5980	5980	4940	4630	6000	5445	5600	4385
	8	6000	6620	5460	5460	6000	6120	6000	4900
200	2	5000	6880	5000 ²⁾	5700 ²⁾	5000	6350	5000 ²⁾	5230 ²⁾
	4	5000	7660	5000	6340	5000	6950	5000	5650
	6	5000	8300	5000	6880	5000	7505	5000	6025
	8	5000	9880	5000	8160	5000	9215	5000	7435
225	2	5000	7380	5000 ³⁾	6120 ³⁾	5000	6770	5000 ³⁾	5490 ³⁾
	4	5000	7600	5000	6220	5000	6795	5000	5475
	6	5000	10140	5000	8420	5000	9270	5000	7490
	8	5000	11 420	5000	9460	5000	10 595	5000	8535
250	2	6000 ⁴⁾	9020 ⁴⁾	6000 ⁴⁾	7500 ⁴⁾	6000 ⁴⁾	8335 ⁴⁾	6000 ⁴⁾	6755 ⁴⁾
	4	6000	9800	6000	8040	6000	8820	6000	7120
	6	6000	11520	6000	9520	6000	10 275	6000	8235
	8	6000	13 700	6000	11 380	6000	12 645	6000	10 205
280	2	5260	5260	4220	4220	6400	4400	5420	3420
	4	6500	6500	5160	5160	7920	5400	6640	4120
	6	7500	7500	6040	6040	8500	6180	7840	4640
	8	7740	7740	6180	6180	8500	6435	7980	4775

¹⁾ The maximum lifetime of the grease is 38 000 h

²⁾ The maximum lifetime of the grease is 27 000 h

³⁾ The maximum lifetime of the grease is 23 000 h

⁴⁾ The maximum lifetime of the grease is 16 000 h

Terminal box

Sizes 63 to 180

The terminal box is made of aluminum alloy and is located on top of the stator. The lower part of the box is integrated with the stator. It is provided with two knockout openings on each side. Sizes 132 SM_ and 160 - 180 also have a third smaller opening. Cable glands are not included.

Sizes 200 to 280

The terminal box and cover are made of deep drawn steel and mounted on top of the stator. The box is bolted to the stator and is not rotatable. The size of the box is the same for all frame sizes.

The motors can also be provided with an extra large terminal box, standard for voltage code S and frame size 280. See variant code 019 under the heading "Terminal box". This will increase the dimension HD by 32 mm. The box is supplied with two FL 21 openings. The right opening is provided with a flange with two holes for M63 cable glands. The holes are sealed by means of plastic plugs. Cable glands are not supplied. The opening on the other side is provided with a cover flange. The box can also be provided with an FL 13 opening towards the N-end.

When new motors are manufactured the terminal box can be mounted on the left or the right side. See variant codes 021 and 180 under the heading "Terminal box".

In the basic design the terminal box is provided with two FL 13 flange openings, one on each side. The opening on the right side, seen from the D-end, is supplied with a flange with two holes for M40 cable glands. On delivery the holes are sealed by means of plastic plugs. Cable glands are not supplied. The opening on the other side is provided with a cover flange.

Dimensions for terminal box

Motor size	Dimensions		
	HB	HD	HE
Code 019: Larger than standard terminal box			
200 ML	332.5	603	240
225 SM	353	578	260.5
250 SM	376	626	283.5
Code 021: Terminal box on left-hand side seen from D end			
Code 180: Terminal box on right-hand side seen from D end			
200 ML	332	532	239
225 SM	354	579	260.5
250 SM	377	627	284
Code 467: Lower than standard terminal box without screw terminals and extended rubber connection cable 2 m.			
160	211.5	371.5	
180	226.5	406.5	
200 ML	248	448	
225 SM	269	494	
250 SM	292	542	
280	292	572	

Refer to the Dimension drawings section for dimensions HB, HD and HE.

Connections

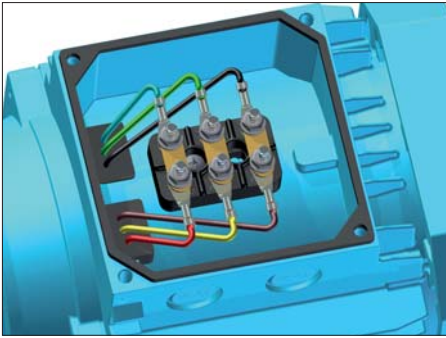

Terminal board for motor sizes 63 to 80

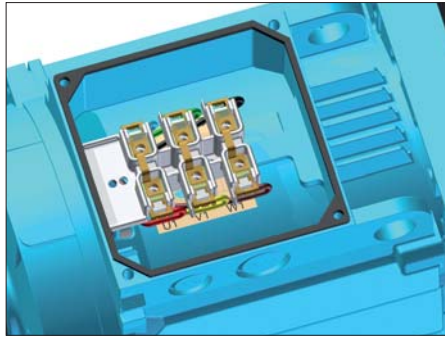

Terminal board for motor sizes 90 to 112

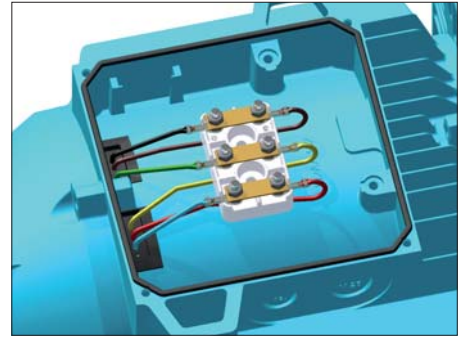

Terminal board for motor size 132

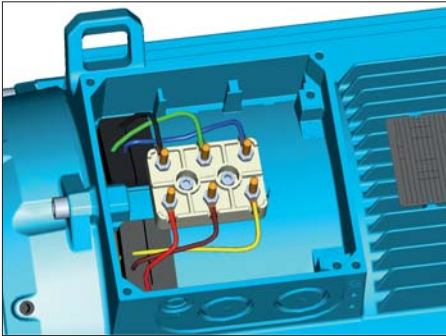

Terminal board for motor sizes 160 to 180

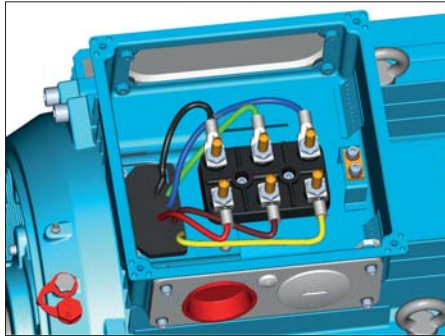

Terminal board for motor sizes 200 to 280

The terminal block is provided with six terminals for connecting Cu-cable.
The terminals are marked in accordance with IEC 60034-8.

Connection openings

Motor size	Opening	Metric cable entry	Method of connection	Terminal bolt size	Maximum connectable Cu-cable area, mm ²
63	Knock-out opening	1 × M16 × 1.5 1 × Pg 11	Cable lug	M4	2.5
71-80	Knock-out opening	2 × (2 × M20)	Cable lug	M4	4
90-112	Knock-out opening	2 × (M25 + M20)	Screw terminal	M4	6
132 ¹⁾	Knock-out opening	2 × (M25 + M20)	Cable lug	M5	10
132 ²⁾	Knock-out opening	2 × (M40 × M32 + M12)	Cable lug	M6	35
160-180	Knock-out opening	2 × (2 × M40) + M16	Cable lug	M6	35
200-250	2 × FL 13	1 × (2 × M40 + M16)	Cable lug	M10	70
280	2 × FL 21	1 × (2 × M63 + M16)	Cable lug	M10	70

¹⁾ all types except ²⁾

²⁾ SM_

Dimension drawings

Foot-mounted aluminum motors, 63 - 112

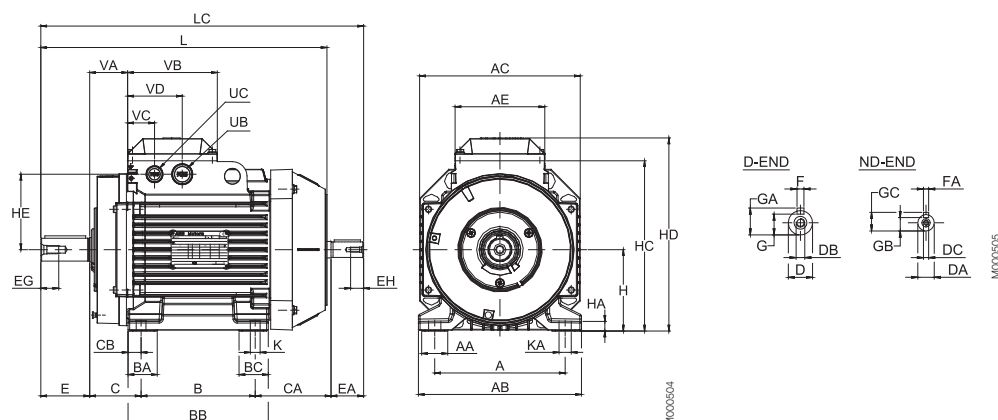

Foot-mounted motor; IM B3 (IM 1001), IM 1002

IM B3 (IM 1001), IM 1002

Motor size	A	AA	AB	AC	AE	B	BA	BB	BC	C	CA	CB	D	DA	DB	DC	E	EA	EG	EH	F
63	100	25	120	120	85	80	32	98	32	40	74	10	11	11	M4	M4	23	23	10	10	4
71	112	23	136	130	97	90	24.5	110	24.5	45	79.5	10	14	11	M5	M4	30	23	12.5	10	5
80 ¹⁾	125	27	154	150	97	100	32	125	32	50	80.5	12.5	19	14	M6	M5	40	30	16	12.5	6
80 ²⁾	125	27	154	150	97	100	32	125	32	50	108	12.5	19	14	M6	M5	40	30	16	12.5	6
90 ³⁾	140	27	170	177	110	100	32	125	32	56	83.5	12.5	24	14	M8	M5	50	30	19	12.5	8
90 ⁴⁾	140	27	170	177	110	125	32	150	32	56	83.5	12.5	24	14	M8	M5	50	30	19	12.5	8
90 ⁵⁾	140	27	170	177	110	125	32	150	32	56	105.5	12.5	24	14	M8	M5	50	30	19	12.5	8
100 ⁶⁾	160	32	200	197	110	140	36	172	36	63	93	16	28	19	M10	M6	60	40	22	16	8
100 ⁷⁾	160	32	200	197	110	140	36	172	36	63	115	16	28	19	M10	M6	60	40	22	16	8
100 ⁸⁾	160	32	200	197	110	140	36	172	36	70	136	16	28	19	M10	M6	60	40	22	16	8
112 ⁹⁾	190	32	230	197	110	140	36	172	36	70	136	16	28	19	M10	M6	60	40	22	16	8
112 ¹⁰⁾	190	41	222	221	160	140	31	168	31	70	91	14	28	19	M10	M8	60	40	22	19	8

Motor size	FA	G	GA	GB	GC	H	HA	HC	HD	HE	K	KA	L	LC	UB	UC	VA	VB	VC	VD
63	4	8.5	12.5	8.5	12.5	63	7	120	151	50	7	11	214	237	pg11	M16x1.5	31	92	30.5	61.5
71	4	11	16	8.5	12.5	71	9	151	180	63.5	7	11	240	267	M20	M20	35			
80 ¹⁾	5	15.5	21.5	11	16	80	10	164.5	193.5	68	10	14	265.5	300.5	M20	M20	37.5	97	30.5	66.5
80 ²⁾	5	15.5	21.5	11	16	80	10	164.5	193.5	68	10	14	293	328	M20	M20	37.5	97	30.5	66.5
90 ³⁾	5	20	27	11	16	90	10	189	217	82.5	10	14	284.5	319.5	M25	M20	43.5	110	33	67
90 ⁴⁾	5	20	27	11	16	90	10	189	217	82.5	10	14	309.5	344.5	M25	M20	43.5	110	33	67
90 ⁵⁾	5	20	27	11	16	90	10	189	217	82.5	10	14	331.5	366.5	M25	M20	43.5	110	33	67
100 ⁶⁾	6	24	31	15.5	21.5	100	12	209	237	92.5	12	15	351	396	M25	M20	46.5	110	33	67
100 ⁷⁾	6	24	31	15.5	21.5	100	12	209	237	92.5	12	15	373	418	M25	M20	46.5	110	33	67
100 ⁸⁾	6	24	31	15.5	21.5	100	12	209	237	92.5	12	15	393	436	M25	M20	46.5	110	33	67
112 ⁹⁾	6	24	31	15.5	21.5	112	12	221	249	92.5	12	15	393	436	M25	M20	46.5	110	33	67
112 ¹⁰⁾	6	24	31	15.5	21.5	112	12	226	258	92	12	15	361	421.5	M25	M20	60	160	80	120

Tolerances

A, B	±0.8
D, DA	ISO j6
F, FA	ISO h9
H	+0 -0.5
N	ISO j6
C, CA	±0.8

¹⁾ IE2: B-2, C-2, A-4, D-4, A-6, B-6, A-8, B-8, C-8

IE3: B-2, C-2

²⁾ IE3: E-4

³⁾ IE2: S-8

⁴⁾ IE2: L-2, L-8, LB-2, LB-4, LB-6, LB-8

IE3: L-2, LB-2, LB-4, LB-6

⁵⁾ IE2: LD-4, LD-6

IE3: LD-4, LD-6

⁶⁾ IE2: LB-2, LC-4, LC-6, LA-8, LB-8, LC-8

IE3: LC-4

⁷⁾ IE2: LD-4

⁸⁾ IE3: LB-2, LC-6, LD-4

⁹⁾ IE2: MB-2, MB-4, MB-6, MB-8, M-8

¹⁰⁾ IE3: MB-2, MB-4, MB-6

Dimension drawings

Flange-mounted aluminum motors, 63 - 112

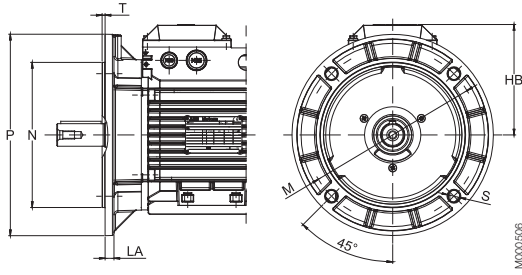

Flange-mounted motor, large flange; IM B5 (IM 3001), IM 3002

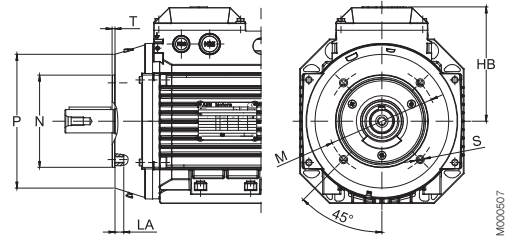

Flange-mounted motor, small flange; IM B14 (IM 3601)

IM B5 (IM3001), IM 3002

Motor size	HB	LA	M	N	P	S	T
63	103	10	100	80	120	7	3
71	109	9.5	130	110	160	10	3.5
80 ¹⁾	113.5	10	165	130	200	12	3.5
80 ²⁾	113.5	10	165	130	200	12	3.5
90 ³⁾	127	10	165	130	200	12	3.5
90 ⁴⁾	127	10	165	130	200	12	3.5
90 ⁵⁾	127	10	165	130	200	12	3.5
100 ⁶⁾	137	11	215	180	250	15	4
100 ⁷⁾	137	11	215	180	250	15	4
100 ⁸⁾	137	11	215	180	250	15	4
112 ⁹⁾	137	11	215	180	250	15	4
112 ¹⁰⁾	146	11	215	180	250	15	4

IM B14 (IM 3601), IM 3602

Motor size	HB	LA	M	N	P	S	T
63	103	10	75	60	90	M5	2.5
71	109	11	85	70	105	M6	3
80 ¹⁾	113.5	11	100	80	120	M6	3
80 ²⁾	113.5	11	100	80	120	M6	3
90 ³⁾	127	13	115	95	140	M8	3
90 ⁴⁾	127	13	115	95	140	M8	3
90 ⁵⁾	127	13	115	95	140	M8	3
100 ⁶⁾	137	14	130	110	160	M8	3.5
100 ⁷⁾	137	14	130	110	160	M8	3.5
100 ⁸⁾	137	14	130	110	160	M8	3.5
112 ⁹⁾	137	14	130	110	160	M8	3.5
112 ¹⁰⁾	146	20	130	110	160	M8	3.5

Tolerances

A, B	±0.8
D, DA	ISO j6
F, FA	ISO h9
H	+0 -0.5
N	ISO j6
C, CA	±0.8

¹⁾ IE2: B-2, C-2, A-4, D-4, A-6, B-6, A-8, B-8, C-8
IE3: B-2, C-2

²⁾ IE3: E-4

³⁾ IE2: S-8

⁴⁾ IE2: L-2, L-8, LB-2, LB-4, LB-6, LB-8

IE3: L-2, LB-2, LB-4, LB-6

⁵⁾ IE2: LD-4, LD-6

IE3: LD-4, LD-6

⁶⁾ IE2: LB-2, LC-4, LC-6, LA-8, LB-8, LC-8

IE3: LC-4

⁷⁾ IE2: LD-4

⁸⁾ IE3: LB-2, LC-6, LD-4

⁹⁾ IE2: MB-2, MB-4, MB-6, MB-8, M-8

¹⁰⁾ IE3: MB-2, MB-4, MB-6

Dimension drawings

Foot- and flange-mounted aluminum motors, 63 - 112

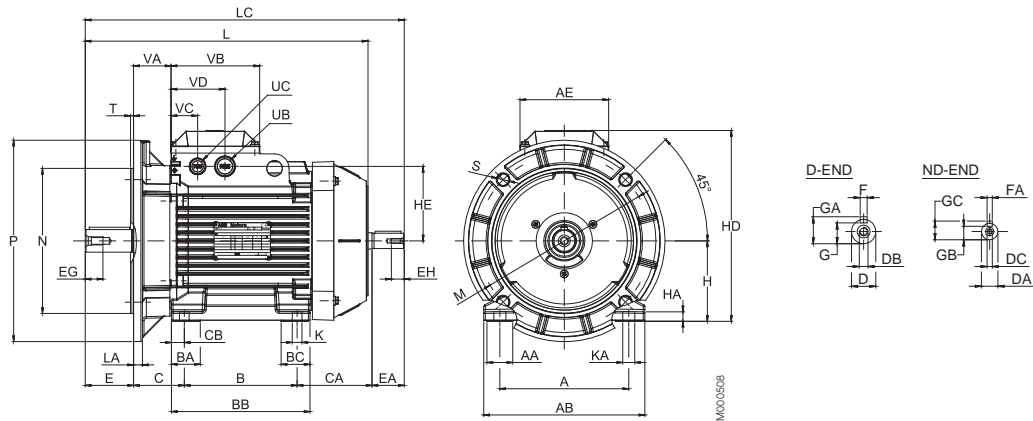

Foot- and flange-mounted motor; IM B35 (IM 2001), IM 2002, large flange

IM B35 (IM 2001), IM 2002; IM B34 (IM 2101), IM 2102

Motor size	A	AA	AB	AC	AE	B	BA	BB	BC	C	CA	CB	D	DA	DB	DC	E	EA	EG	EH	F
63	100	25	120	120	85	80	32	98	32	40	74	10	11	11	M4	M4	23	23	10	10	4
71	112	23	136	130	97	90	24.5	110	24.5	45	79.5	10	14	11	M5	M4	30	23	12.5	10	5
80 ¹⁾	125	27	154	150	97	100	32	125	32	50	80.5	12.5	19	14	M6	M5	40	30	16	12.5	6
80 ²⁾	125	27	154	150	97	100	32	125	32	50	108	12.5	19	14	M6	M5	40	30	16	12.5	6
90 ³⁾	140	27	170	177	110	100	32	125	32	56	83.5	12.5	24	14	M8	M5	50	30	19	12.5	8
90 ⁴⁾	140	27	170	177	110	125	32	150	32	56	83.5	12.5	24	14	M8	M5	50	30	19	12.5	8
90 ⁵⁾	140	27	170	177	110	125	32	150	32	56	105.5	12.5	24	14	M8	M5	50	30	19	12.5	8
100 ⁶⁾	160	32	200	197	110	140	36	172	36	63	93	16	28	19	M10	M6	60	40	22	16	8
100 ⁷⁾	160	32	200	197	110	140	36	172	36	63	115	16	28	19	M10	M6	60	40	22	16	8
100 ⁸⁾	160	32	200	197	110	140	36	172	36	70	136	16	28	19	M10	M6	60	40	22	16	8
112 ⁹⁾	190	32	230	197	110	140	36	172	36	70	136	16	28	19	M10	M6	60	40	22	16	8
112 ¹⁰⁾	190	41	222	221	160	140	31	168	31	70	91	14	28	19	M10	M8	60	40	22	19	8

Motor size	FA	G	GA	GB	GC	H	HA	HC	HD	HE	K	KA	L	LC	UB	UC	VA	VB	VC	VD
63	4	8.5	12.5	8.5	12.5	63	7	120	151	50	7	11	214	237	pg11	M16×1.5	31	92	30.5	61.5
71	4	11	16	8.5	12.5	71	9	151	180	63.5	7	11	240	267	M20	M20	35			
80 ¹⁾	5	15.5	21.5	11	16	80	10	164.5	193.5	68	10	14	265.5	300.5	M20	M20	37.5	97	30.5	66.5
80 ²⁾	5	15.5	21.5	11	16	80	10	164.5	193.5	68	10	14	293	328	M20	M20	37.5	97	30.5	66.5
90 ³⁾	5	20	27	11	16	90	10	189	217	82.5	10	14	284.5	319.5	M25	M20	43.5	110	33	67
90 ⁴⁾	5	20	27	11	16	90	10	189	217	82.5	10	14	309.5	344.5	M25	M20	43.5	110	33	67
90 ⁵⁾	5	20	27	11	16	90	10	189	217	82.5	10	14	331.5	366.5	M25	M20	43.5	110	33	67
100 ⁶⁾	6	24	31	15.5	21.5	100	12	209	237	92.5	12	15	351	396	M25	M20	46.5	110	33	67
100 ⁷⁾	6	24	31	15.5	21.5	100	12	209	237	92.5	12	15	373	418	M25	M20	46.5	110	33	67
100 ⁸⁾	6	24	31	15.5	21.5	100	12	209	237	92.5	12	15	393	436	M25	M20	46.5	110	33	67
112 ⁹⁾	6	24	31	15.5	21.5	112	12	221	249	92.5	12	15	393	436	M25	M20	46.5	110	33	67
112 ¹⁰⁾	6	24	31	15.5	21.5	112	12	226	258	92	12	15	361	421.5	M25	M20	60	160	80	120

Tolerances

A, B	± 0.8
D, DA	ISO j6
F, FA	ISO h9
H	+0 -0.5
N	ISO j6
C, CA	± 0.8

¹⁾ IE2: B-2, C-2, A-4, D-4, A-6, B-6, A-8, B-8, C-8

IE3: B-2, C-2

²⁾ IE3: E-4

³⁾ IE2: S-8

⁴⁾ IE2: L-2, L-8, LB-2, LB-4, LB-6, LB-8

IE3: L-2, LB-2, LB-4, LB-6

⁵⁾ IE2: LD-4, LD-6

IE3: LD-4, LD-6

⁶⁾ IE2: LB-2, LC-4, LC-6, LA-8, LB-8, LC-8

IE3: LC-4

⁷⁾ IE2: LD-4

⁸⁾ IE3: LB-2, LC-6, LD-4

⁹⁾ IE2: MB-2, MB-4, MB-6, MB-8, M-8

¹⁰⁾ IE3: MB-2, MB-4, MB-6

Dimension drawings

Foot- and flange-mounted aluminum motors, 63 - 112

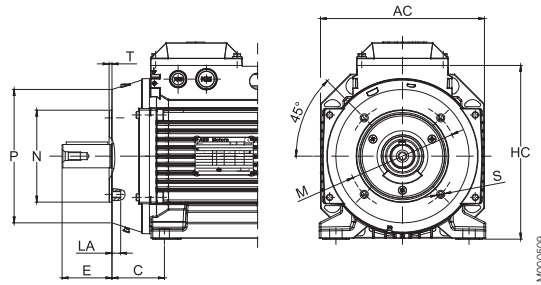

Foot- and flange-mounted motor; IM B34 (IM 2101), IM 2102, small flange

IM B35 (IM 2001), IM 2002

Motor size	HB	LA	M	N	P	S	T
63	103	10	100	80	120	7	3
71	109	9.5	130	110	160	10	3.5
80 ¹⁾	113.5	10	165	130	200	12	3.5
80 ²⁾	113.5	10	165	130	200	12	3.5
90 ³⁾	127	10	165	130	200	12	3.5
90 ⁴⁾	127	10	165	130	200	12	3.5
90 ⁵⁾	127	10	165	130	200	12	3.5
100 ⁶⁾	137	11	215	180	250	15	4
100 ⁷⁾	137	11	215	180	250	15	4
100 ⁸⁾	137	11	215	180	250	15	4
112 ⁹⁾	137	11	215	180	250	15	4
112 ¹⁰⁾	146	11	215	180	250	15	4

IM B34 (IM 2101), IM 2102

Motor size	HB	LA	M	N	P	S	T
63	103	10	65	50	80	M5	2.5
71	109	11	85	70	105	M6	3
80 ¹⁾	113.5	11	100	80	120	M6	3
80 ²⁾	113.5	11	100	80	120	M6	3
90 ³⁾	127	13	115	95	140	M8	3
90 ⁴⁾	127	13	115	95	140	M8	3
90 ⁵⁾	127	13	115	95	140	M8	3
100 ⁶⁾	137	14	130	110	160	M8	3.5
100 ⁷⁾	137	14	130	110	160	M8	3.5
100 ⁸⁾	137	14	130	110	160	M8	3.5
112 ⁹⁾	137	14	130	110	160	M8	3.5
112 ¹⁰⁾	146	20	130	110	160	M8	3.5

Tolerances

A, B	± 0.8
D, DA	ISO j6
F, FA	ISO h9
H	+0 -0.5
N	ISO j6
C, CA	± 0.8

¹⁾ IE2: B-2, C-2, A-4, D-4, A-6, B-6, A-8, B-8, C-8
IE3: B-2, C-2

²⁾ IE3: E-4

³⁾ IE2: S-8

⁴⁾ IE2: L-2, L-8, LB-2, LB-4, LB-6, LB-8

IE3: L-2, LB-2, LB-4, LB-6

⁵⁾ IE2: LD-4, LD-6

IE3: LD-4, LD-6

⁶⁾ IE2: LB-2, LC-4, LC-6, LA-8, LB-8, LC-8

IE3: LC-4

⁷⁾ IE2: LD-4

⁸⁾ IE3: LB-2, LC-6, LD-4

⁹⁾ IE2: MB-2, MB-4, MB-6, MB-8, M-8

¹⁰⁾ IE3: MB-2, MB-4, MB-6

Dimension drawings

Special design aluminum motors with two-piece flanges, 71 - 132

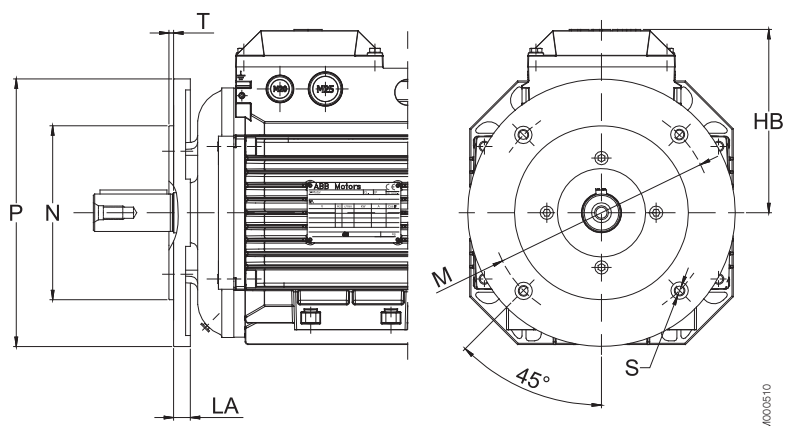

Motor size	IEC flange	Flange dimensions							Variant code	
		HB	P	M	N	LA	S	T	FF	FT
71	FT85	105	105	85	70	7.5	M6	2.5	-	218
	FF100/FT100	105	120	100	80	7.5	M6	3	220	219
	FF115/FT115	105	140	115	95	9.5	M8	3	223	224
	FF130/FT130	105	160	130	110	9.5	M8	3.5	226	227
	FF165/FT165	105	200	165	130	10.5	M10	3.5	233	234
80	FT85	110	105	85	70	7.5	M6	2.5	-	218
	FF100/FT100	110	120	100	80	7.5	M6	3	220	219
	FF115/FT115	110	140	115	95	9.5	M8	3	223	224
	FF130/FT130	110	160	130	110	9.5	M8	3.5	226	227
	FF165/FT165	110	200	165	130	10.5	M10	3.5	233	234
90	FT85	127	105	85	70	7.5	M6	2.5	-	218
	FF100/FT100	127	120	100	80	7.5	M6	3	220	219
	FF115/FT115	127	140	115	95	9.5	M8	3	223	224
	FF130/FT130	127	160	130	110	9.5	M8	3.5	226	227
	FF165/FT165	127	200	165	130	10.5	M10	3.5	233	234
100	FF130/FT130	137	160	130	110	9.5	M8	3.5	226	227
	FF165/FT165	137	200	165	130	10.5	M10	3.5	233	234
	FF215/FT215	137	250	215	180	12.5	M12	4	243	244
112	FF130/FT130	137	160	130	110	9.5	M8	3.5	226	227
	FF165/FT165	137	200	165	130	10.5	M10	3.5	233	234
	FF215/FT215	137	250	215	180	12.5	M12	4	243	244
132	FF215/FT215	164	250	215	180	12.5	M12	4	243	244
	FF265/FT265	164	300	265	230	16	M12	4	253	254

Tolerances

N	ISO j6
---	--------

Dimension drawings

Foot- and flange-mounted aluminum motors, 132

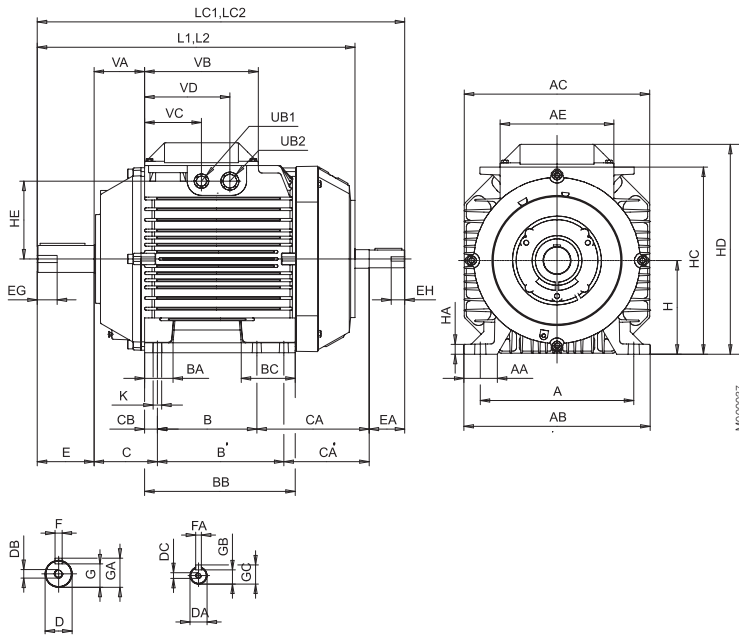

Foot-mounted motor; IM B3 (IM 1001), IM 1002

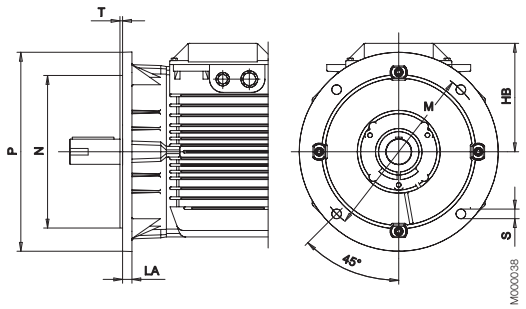

Flange-mounted motor, large flange; IM B5 (IM 3001), IM 3002

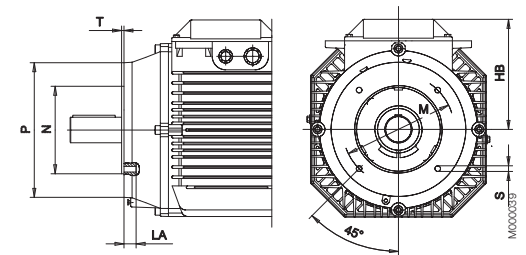

Flange-mounted motor, small flange; IM B14 (IM 3601), IM 3602

IM B3 (IM 1001), IM 1002

Motor size	A	AA	AB	AC	AE	B	B'	BA	BB	BC	C	CA	CA'	CB	D	DA	DB	DC	E	EA	EG	EH	F
132 ¹⁾	216	47	262	261	160	140	178	40	212	76	89	158	120	18	38	24	M12	M8	80	50	28	19	10
132 ²⁾	216	47	262	261	160	140	178	40	212	76	89	178	140	18	38	24	M12	M8	80	50	28	19	10
132 SM ₋	216	47	262	261	160	140	178	40	212	76	89	261	223	18	38	24	M12	M8	80	50	28	19	10

Motor size	FA	G	GA	GB	GC	H	HA	HC	HD	HE	K	KA	L	LC	UB1	UB2	UD	VA	VB	VC	VD	VE
132 ¹⁾	8	33	41	20	27	132	14	263.5	295.5	109.5	12	15	447	517	M20	M25	-	71	160	80	120	
132 ²⁾	8	33	41	20	27	132	14	263.5	295.5	109.5	12	15	487	537	M20	M25	-	71	160	80	120	
132 SM ₋	8	33	41	20	27	132	14	287	321	123.5	12	15	550	620	M40	M32	M12	71	160	42	102	136

IM B5 (IM3001), IM 3002

Motor size	HB	LA	M	N	P	S	T
132 ¹⁾	163.5	14	265	230	300	14.5	4
132 ²⁾	163.5	14	265	230	300	14.5	4
132 SM ₋	189	14	265	230	300	14.5	4

IM B14 (IM 3601), 3602

Motor size	HB	LA	M	N	P	S	T
132 ¹⁾	163.5	14.5	165	130	200	M10	3.5
132 ²⁾	163.5	14.5	165	130	200	M10	3.5
132 SM ₋	189	14.5	165	130	200	M10	3.5

Tolerances

A, B	ISO js14
C, CA	+2 -2
D	ISO k6
DA	ISO j6
F, FA	ISO h9
H	+0 -0.5
N	ISO j6

¹⁾ IE2: SB-2, M-4, MA-4, MBA-4

IE3: M-4, MA-4, S-6

²⁾ IE2: SC-2, MC-6

IE3: SB-2, SC-2, MA-6, MC-6

Dimension drawings

Foot- and flange-mounted aluminum motors, 132

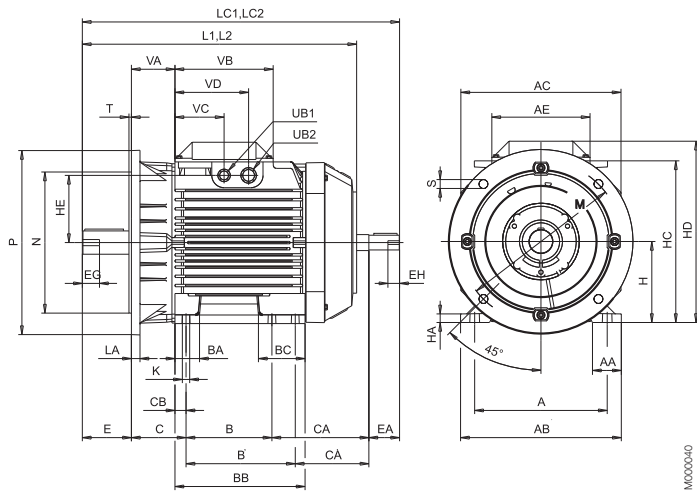

Foot- and flange-mounted motor; IM B35 (IM 2001), IM 2002, large flange

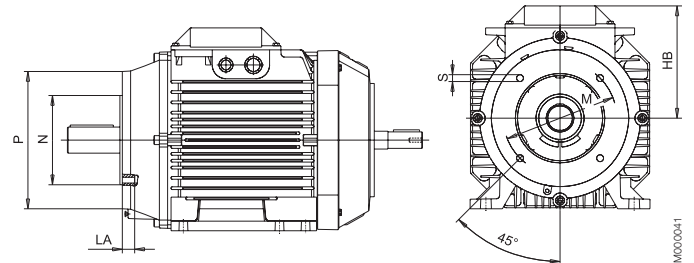

Foot- and flange-mounted motor; IM B34 (IM 2101), IM 2102, small flange

IM B3 (IM 2001), IM 2002

Motor size	A	AA	AB	AC	AE	B	B'	BA	BB	BC	C	CA	CA'	CB	D	DA	DB	DC	E	EA	EG	EH	F
132 ¹⁾	216	47	262	261	160	140	178	40	212	76	89	158	120	18	38	24	M12	M8	80	50	28	19	10
132 ²⁾	216	47	262	261	160	140	178	40	212	76	89	178	140	18	38	24	M12	M8	80	50	28	19	10
132 SM_	216	47	262	261	160	140	178	40	212	76	89	261	223	18	38	24	M12	M8	80	50	28	19	10

Motor size	FA	G	GA	GB	GC	H	HA	HC	HD	HE	K	KA	L	LC	UB1	UB2	UD	VA	VB	VC	VD	VE
132 ¹⁾	8	33	41	20	27	132	14	263.5	295.5	109.5	12	15	447	517	M20	M25	-	71	160	80	120	
132 ²⁾	8	33	41	20	27	132	14	263.5	295.5	109.5	12	15	487	537	M20	M25	-	71	160	80	120	
132 SM_	8	33	41	20	27	132	14	287	321	123.5	12	15	550	620	M40	M32	M12	71	160	42	102	136

IM B35 (IM 2001)

Motor size	HB	LA	M	N	P	S	T
132 ¹⁾	163.5	14	265	230	300	14.5	4
132 ²⁾	163.5	14	265	230	300	14.5	4
132 SM_	189	14	265	230	300	14.5	4

IM B34 (IM 2101)

Motor size	HB	LA	M	N	P	S	T
132 ¹⁾	163.5	14.5	165	130	200	M10	3.5
132 ²⁾	163.5	14.5	165	130	200	M10	3.5
132 SM_	189	14.5	165	130	200	M10	3.5

Tolerances

A, B	ISO js14
C, CA	+2 -2
D	ISO k6
DA	ISO j6
F, FA	ISO h9
H	+0 -0.5
N	ISO j6

- 1) IE2: SB-2, M-4, MA-4, MBA-4
IE3: M-4, MA-4, S-6
- 2) IE2: SC-2, MC-6
IE3: SB-2, SC-2, MA-6, MC-6

Dimension drawings

Foot-mounted aluminum motors, 160 - 180

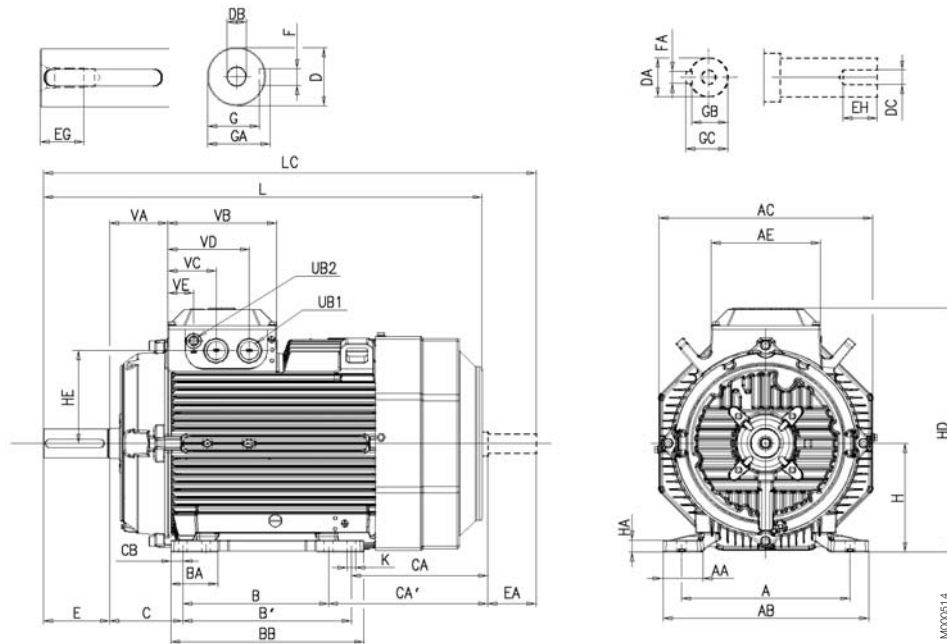

Foot-mounted motor; IM B3 (IM 1001), IM 1002

IM B3 (IM 1001), IM 1002

Motor size	A	AA	AB	AC	AE	B	B'	BA	BB	C	CA	CA'	CB	D	DA	DB	DC	E	EA
160 ¹⁾	254	54	310	323	180	210	254	84	294	108	172	128	20	42	32	M16	M12	110	80
160 ²⁾	254	54	310	323	180	210	254	84	294	108	269	225	20	42	32	M16	M12	110	80
180	279	68	341	354	180	241	279	78	319	121	263	225	20	48	32	M16	M12	110	80

Motor size	EG	EH	F	FA	G	GA	GB	GC	H	HA	HC	HD	HE	K	L	LC	UB1 ³⁾	UB2 ³⁾	VA
160 ¹⁾	36	28	12	10	37	45	27	35	160	20	342	370	139	15	584	680	2*M40	M16	88.5
160 ²⁾	36	28	12	10	37	45	27	35	160	20	342	370	139	15	681	777	2*M40	M16	88.5
180	36	28	14	10	42.5	51.5	27	35	180	20	369	405	154	15	726	815	2*M40	M16	88.5

Motor size	VB	VC	VD	VE
160 ¹⁾	180	80	135.5	43
160 ²⁾	180	80	135.5	43
180	180	80	135.5	43

Tolerances

A, B	ISO js14
C, CA	± 0.8
D, DA	ISO k6
F, FA	ISO h9
H	+0 -0.5

M3AA IE2:

- ¹⁾ MLA-2, MLB-2, MLC-2, MLA-4, MLA-6, MLA-8 and MLB 8-poles
- ²⁾ MLD-2, MLE-2, MLB-4, MLC-4, MLD-4, MLB-6, MLC-6 and MLC-8 poles

M3AA IE3:

- ¹⁾ MLA-2
- ²⁾ MLB-2, MLC-2, all 4- and 6-poles
- ³⁾ Knock-out openings

Dimension drawings

Flange-mounted aluminum motors, 160 - 180

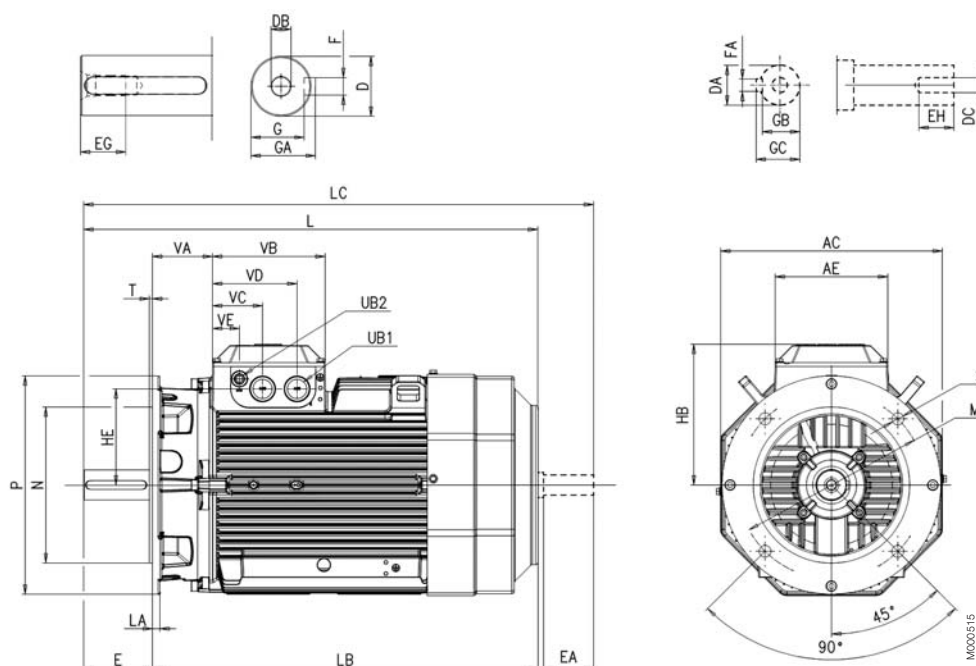

Flange-mounted motor; IM B5 (IM 3001), IM 3002

IM B5 (IM 3001), IM 3002

Motor size	AC	AE	D	DA	DB	DC	E ⁴⁾	EA	EG	EH	F	FA	G	GA	GB	GC	HB
160 ¹⁾	323	180	42	32	M16	M12	110	80	36	28	12	10	37	45	27	35	210
160 ²⁾	323	180	42	32	M16	M12	110	80	36	28	12	10	37	45	27	35	210
180	354	180	48	32	M16	M12	110	80	36	28	14	10	42.5	51.5	27	35	225

Motor size	HE	L	LA	LB	LC	M	N	P	S	T	UB1 ³⁾	UB2 ³⁾	VA	VB	VC	VD	VE
160 ¹⁾	139	681	20	474	680	300	250	350	19	5	2*M40	M16	88.5	180	43	80	135.5
160 ²⁾	139	681	20	571	777	300	250	350	19	5	2*M40	M16	88.5	180	43	80	135.5
180	154	726	15	616	815	300	250	350	19	5	2*M40	M16	88.5	180	43	80	135.5

Tolerances

D, DA	ISO k6
F, FA	ISO h9
N	ISO j6

M3AA IE2:

- ¹⁾ MLA-2, MLB-2, MLC-2, MLA-4, MLA-6, MLA-8 and MLB 8-poles
- ²⁾ MLD-2, MLE-2, MLB-4, MLC-4, MLD-4, MLB-6, MLC-6 and MLC-8 poles

M3AA IE3:

- ¹⁾ MLA-2
- ²⁾ MLB-2, MLC-2, all 4- and 6-poles
- ³⁾ Knock-out openings
- ⁴⁾ Shoulder of shaft extension and contact surface of flange are in the same plane.

Dimension drawings

Foot- and flange-mounted aluminum motors, 160 - 180

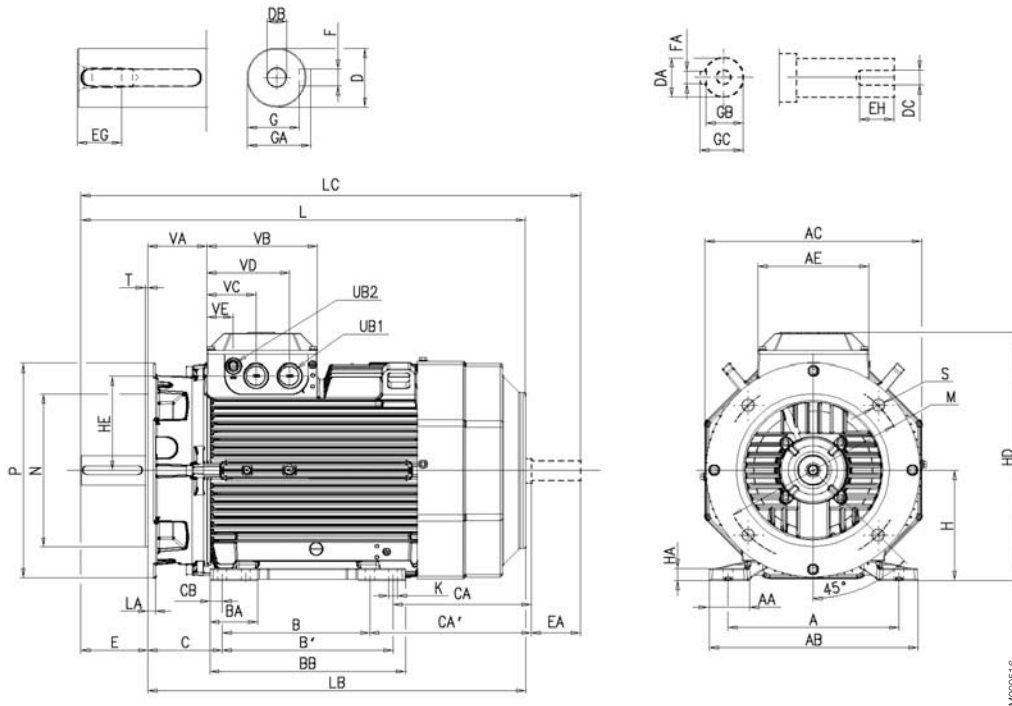

Foot- and flange-mounted motor; IM B35 (IM 2001), IM 2002

IM B35 (IM 2001), IM 2002

Motor size	A	AA	AB	AC	AE	B	B'	BA	BB	C	CA	CA'	CB	D	DA	DB	DC	E ⁴⁾	EA
160 ¹⁾	254	54	310	323	180	210	254	84	294	108	172	128	20	42	32	M16	M12	110	80
160 ²⁾	254	54	310	323	180	210	254	84	294	108	269	225	20	42	32	M16	M12	110	80
180	279	68	341	354	180	241	279	78	319	121	263	225	20	48	32	M16	M12	110	80

Motor size	EG	EH	F	FA	G	GA	GB	GC	H	HA	HC	HD	HE	K	L	LA	LB	LC	M
160 ¹⁾	36	28	12	10	37	45	27	35	160	20	342	370	139	14.5	584	20	474	680	300
160 ²⁾	36	28	12	10	37	45	27	35	160	20	342	370	139	14.5	681	20	571	777	300
180	36	28	14	10	42.5	51.5	27	35	180	20	369	405	154	14.5	726	15	616	815	300

Motor size	N	P	S	T	UB1 ³⁾	UB2 ³⁾	VA	VB	VC	VD	VE
160 ¹⁾	250	350	19	5	2*M40	M16	88.5	180	80	135.5	43
160 ²⁾	250	350	19	5	2*M40	M16	88.5	180	80	135.5	43
180	250	350	19	5	2*M40	M16	88.5	180	80	135.5	43

Tolerances

A, B	ISO js14
C, CA	±8
D, DA	ISO k6
F, FA	ISO h9
H	+0 - 0.5
N	ISO j6

M3AA IE2:

- ¹⁾ MLA-2, MLB-2, MLC-2, MLA-4, MLA-6, MLA-8 and MLB 8-poles
- ²⁾ MLD-2, MLE-2, MLB-4, MLC-4, MLD-4, MLB-6, MLC-6 and MLC-8 poles

M3AA IE3:

- ¹⁾ MLA-2
- ²⁾ MLB-2, MLC-2, all 4- and 6-poles

³⁾ Knock-out openings

⁴⁾ Shoulder of shaft extension and contact surface of flange are in same plane.

Dimension drawings

Foot-mounted aluminum motors, 200 - 225

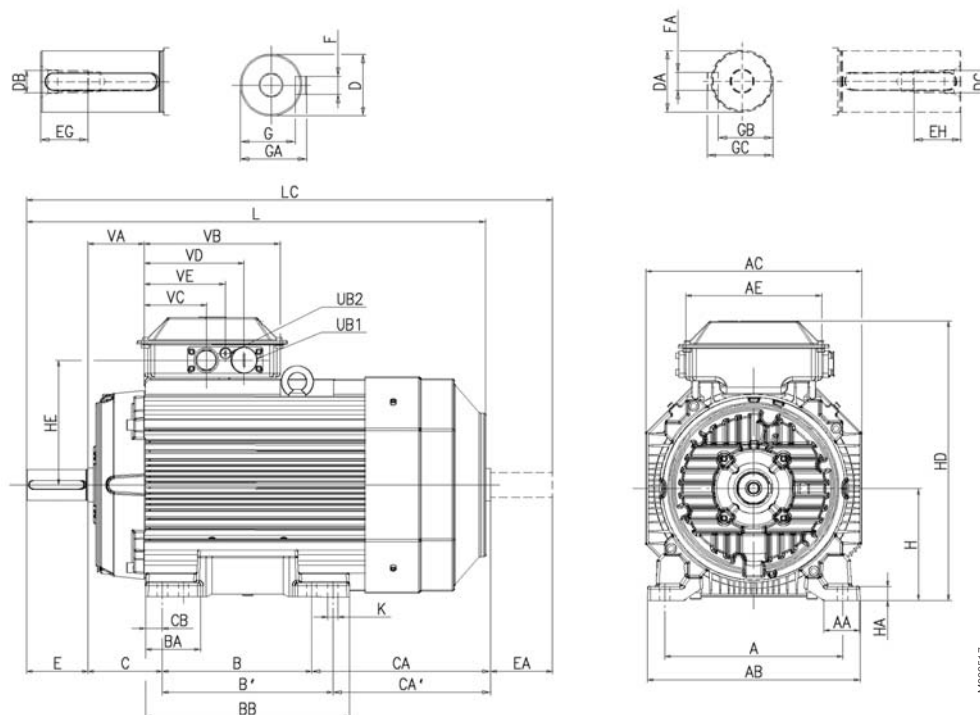

Foot-mounted motor; IM B3 (IM 1001), IM 1002

IM B3 (IM 1001), IM 1002

Motor size	Poles	A	AA	AB	AC	AE	B	B'	BA	BB	C	CA	CA'	CB	D	DA	DB	DC	E	EA
200		318	64	380	386	243	267	305	112	365	133	314	276	30	55	45	M20	M16	110	110
225	2	356	69	418	425	243	286	311	102	365	149	314	289	24.5	55	55	M20	M20	110	110
225	4-8	356	69	418	425	243	286	311	102	365	149	314	289	24.5	60	55	M20	M20	140	110

Motor size	Poles	EG	EH	F	FA	G	GA	GB	GC	H	HA	HD ²⁾	HD ³⁾	HE ²⁾	HE ³⁾	K	L	LC	UB ¹⁾
200		42	36	16	14	49	59	39.5	48.5	200	25	500	532	224	239	18	821	934	2×FL13
225	2	42	42	16	14	49	59	49	59	225	25	547	579	244.5	260	18	850	971	2×FL13
225	4-8	42	42	18	16	53	64	49	59	225	25	547	579	244.5	260	18	880	1001	2×FL13

Motor size	Poles	VA	VB	VC ²⁾	VC ³⁾	VD ²⁾	VD ³⁾	VE ²⁾	VE ³⁾
200		101	243	112	77	179	167	145	122
225	2	93.5	243	112	77	179	167	145	122
225	4-8	93.5	243	112	77	179	167	145	122

Tolerances

A,B	ISO js14
C, CA	± 0.8
D 55-65	ISO m6
DA 45-55	ISO k6
F, FA	ISO h9
H	+0 -0.5

¹⁾ Flange opening is provided with pipe flange FL 13, with tapped lead-in holes plugged with sealing plugs. Single- and two-speed motors: 2 × M40 + M16. Motors for 230VD 50Hz or 225 SMC-2, 225 SMD-2, 225 SMD-4 have pipe flange FL21 and 2 × M63 + M16

²⁾ For flange opening FL13: 2 × M40 + M16

³⁾ For extra large flange opening FL21: 2 × M63 + M16

Dimension drawings

Flange-mounted aluminum motors, 200 - 225

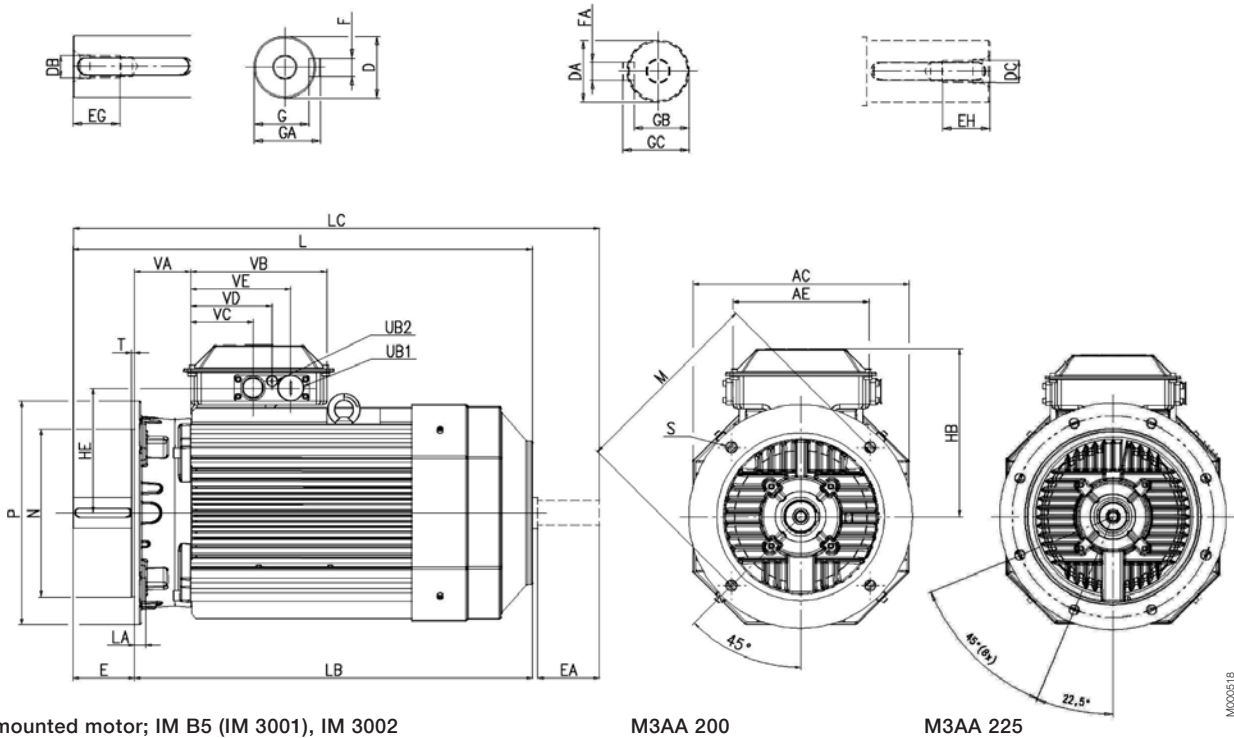

Flange-mounted motor; IM B5 (IM 3001), IM 3002

M3AA 200

M3AA 225

IM B5 (IM 3001), IM 3002

Motor size	Poles	AC	AE	D	DA	DB	DC	E ¹⁾	EA	EG	EH	F	FA	G	GA	GB	GC	HB ³⁾	HB ⁴⁾	HE ³⁾
200		386	243	55	45	M20	M16	110	110	42	36	14	16	49	59	39.5	48.5	300	332	224
225	2	425	243	55	55	M20	M20	110	110	42	42	16	16	49	59	49	59	300	332	244
225	4-8	425	243	60	55	M20	M20	140	110	42	42	16	16	53	64	49	59	322	354	244

Motor size	Poles	HE ⁴⁾	L	LA	LB	LC	M	N	P	S	T	UB ²⁾	VA	VB	VC ³⁾	VC ⁴⁾	VD ³⁾	VD ⁴⁾	VE ³⁾	VE ⁴⁾
200		239	821	20	711	934	350	300	400	19	5	2×FL13	101	243	112	77	179	167	145	122
225	2	260	850	22	740	971	400	350	450	19	5	2×FL13	93.5	243	112	77	179	167	145	122
225	4-8	260	880	22	740	1001	400	350	450	19	5	2×FL13	93.5	243	112	77	179	167	145	122

Tolerances

D 55-65	ISO m6
DA 45-55	ISO k6
F, FA	ISO h9
N	ISO j6

¹⁾ Shoulder of shaft extension and contact surface of flange are in the same plane.

²⁾ Flange opening is provided with pipe flange FL 13, with tapped lead-in holes plugged with sealing plugs. Single- and two-speed motors: 2 × M40 + M16. Motors for 230VD 50Hz or 225 SMC-2, 225 SMD-2, 225 SMD-4 have pipe flange FL21 and 2 × M63 + M16

³⁾ For flange opening FL13: 2 × M40 + M16

⁴⁾ For extra large flange opening FL21: 2 × M63 + M16

Dimension drawings

Foot- and flange-mounted aluminum motors, 200 - 225

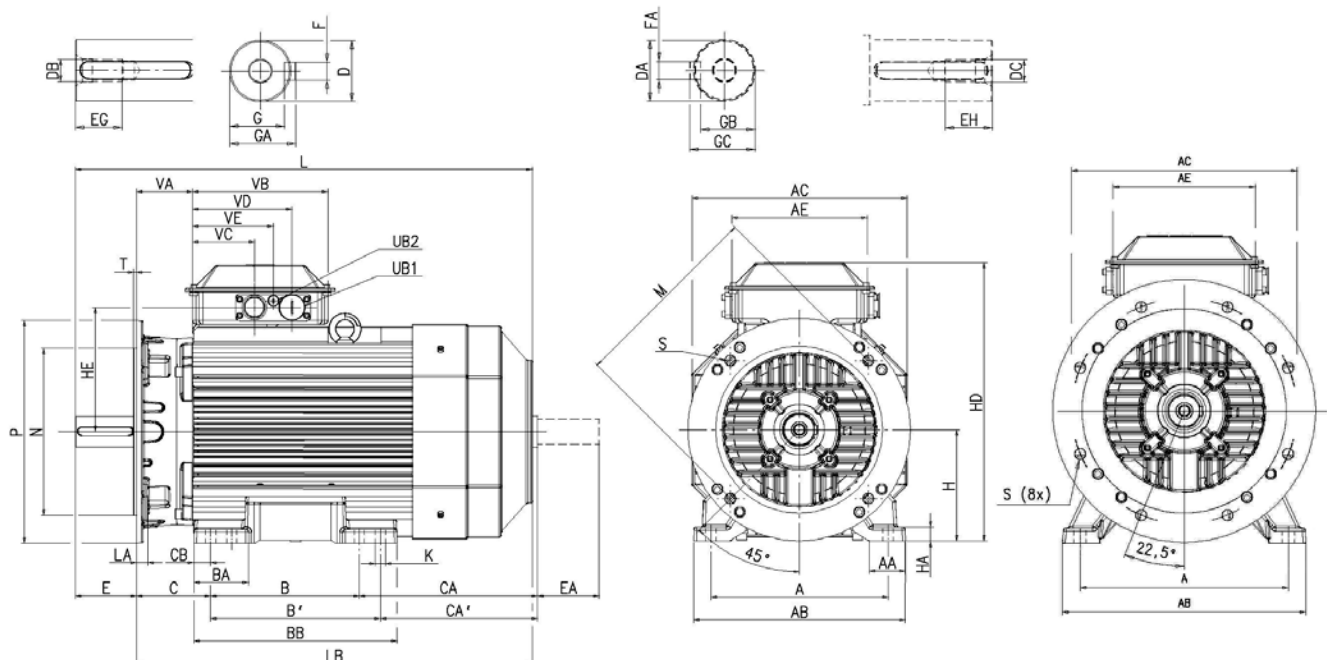

Foot- and flange-mounted motor; IM B35 (IM 2001), IM 2002

M3AA 200

M3AA 225

IM B35 (IM 2001), IM 2002

Motor size	Poles	A	AA	AB	AC	AE	B	B'	BA	BB	C	CA	CA'	CB	D	DA	DB	DC	E ¹⁾	EA
200		318	64	380	386	243	267	305	112	365	133	314	276	30	55	45	M20	M16	110	110
225	2	356	69	418	425	243	286	311	102	365	149	314	289	24.5	55	55	M20	M20	110	110
225	4-8	356	69	418	425	243	286	311	102	365	149	314	289	24.5	60	55	M20	M20	140	110

Motor size	Poles	EG	EH	F	FA	G	GA	GB	GC	H	HA	HD ³⁾	HD ⁴⁾	HE ³⁾	HE ⁴⁾	K	L	LA	LB	LC
200		42	36	16	14	49	59	39.5	48.5	200	25	500	532	223	239	18	821	20	711	934
225	2	42	42	16	14	49	59	49	59	225	25	547	579	244	260	18	850	22	740	971
225	4-8	42	42	18	16	53	64	49	59	225	25	547	579	244	260	18	880	22	740	1001

Motor size	Poles	M	N	P	S	T	UB ²⁾	VA	VB	VC ³⁾	VC ⁴⁾	VD ³⁾	VD ⁴⁾	VE ³⁾	VE ⁴⁾
200		350	300	400	19	5	2xFL13	101	243	112	77	179	167	145	122
225	2	400	350	450	19	5	2xFL13	93.5	243	112	77	179	167	145	122
225	4-8	400	350	450	19	5	2xFL13	93.5	243	112	77	179	167	145	122

Tolerances

A, B	ISO js14
C, CA	± 0.8
D 55-75	ISO m6
DA 45-55	ISO k6
F, FA	ISO h9
H	+0 -0.5
N	ISO j6

¹⁾ Shoulder of shaft extension and contact surface of flange are in the same plane.

²⁾ Flange opening is provided with pipe flange FL 13, with tapped lead-in holes plugged with sealing plugs. Single- and two-speed motors: 2 x M40 + M16. Motors for 230VD 50Hz or 225 SMC-2, 225 SMD-2, 225 SMD-4 have pipe flange FL21 and 2 x M63 + M16

³⁾ For flange opening FL13: 2 x M40 + M16

⁴⁾ For extra large flange opening FL21: 2 x M63 + M16

Dimension drawings

Foot-mounted aluminum motors, 250 - 280

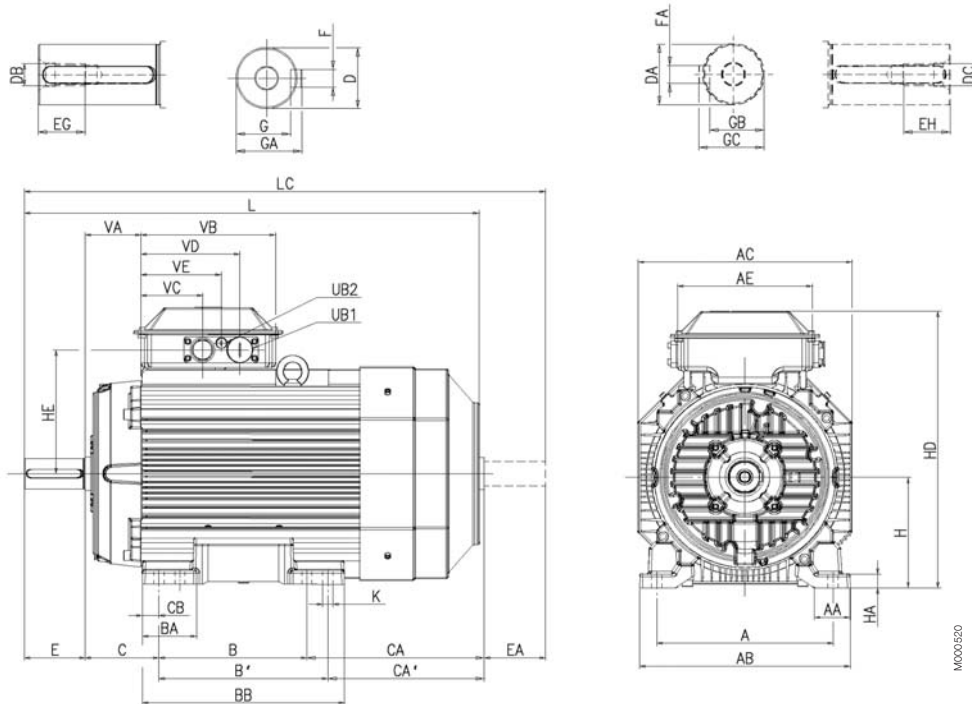

Foot-mounted motor; IM B3 (IM 1001), IM 1002

IM B3 (IM 1001), IM 1002

Motor size	Poles	A	AA	AB	AC	AE	B	B'	BA	BB	C	CA	CA'	CB	D	DA	DB	DC	E	EA
250	2	406	78	473	471	243	311	349	106	409	168	281	243	40	60	55	M20	M20	140	110
250	4-8	406	78	473	471	243	311	349	106	409	168	281	243	30	65	55	M20	M20	140	110
280	2	457	102.5	522	471	243	368	419	92	489	190	202	151	37.5	65	55	M20	M20	140	110
280	4-8	457	102.5	522	471	243	368	419	92	489	190	202	151	37.5	75	55	M20	M20	140	110

Motor size	Poles	EG	EH	F	FA	G	GA	GB	GC	H	HA	HD ²⁾	HD ³⁾	HE ²⁾	HE ³⁾	K	L	LC	UB ¹⁾	VA
250	2	42	42	18	16	53	64	49	59	250	30	594	627	268	284	22	884	1010	2×FL13	93.5
250	4-8	42	42	18	16	58	69	49	59	250	30	594	627	268	284	22	884	1010	2×FL13	93.5
280	2	42	42	18	16	58	69	49	59	280	40	-	657	-	284	24	884	1010	2×FL21	93.5
280	4-8	42	42	20	16	67.5	79.5	49	59	280	40	-	657	-	284	24	884	1010	2×FL21	93.5

Motor size	Poles	VB	VC ³⁾	VC ⁴⁾	VD ³⁾	VD ⁴⁾	VE ³⁾	VE ⁴⁾
250	2	243	112	77	179	167	145	122
250	4-8	243	112	77	179	167	145	122
280	2	243	-	77	-	167	-	122
280	4-8	243	-	77	-	167	-	122

Tolerances

A, B	ISO js14
C, CA	± 0.8
D 55-75	ISO m6
DA 45-55	ISO k6
F, FA	ISO h9
H	+0 -0.5

¹⁾ Flange opening is provided with pipe flange FL 13, with tapped lead-in holes plugged with sealing plugs. Single- and two-speed motors: 2 × M40 + M16. Motors for 230VD 50Hz or 250 SMC-2, 250 SMC-4 and all 280 have pipe flange FL21 and 2 × M63 + M16

²⁾ For flange opening FL13: 2 × M40 + M16

³⁾ For extra large flange opening FL21: 2 × M63 + M16

Dimension drawings

Flange-mounted aluminum motors, 250 - 280

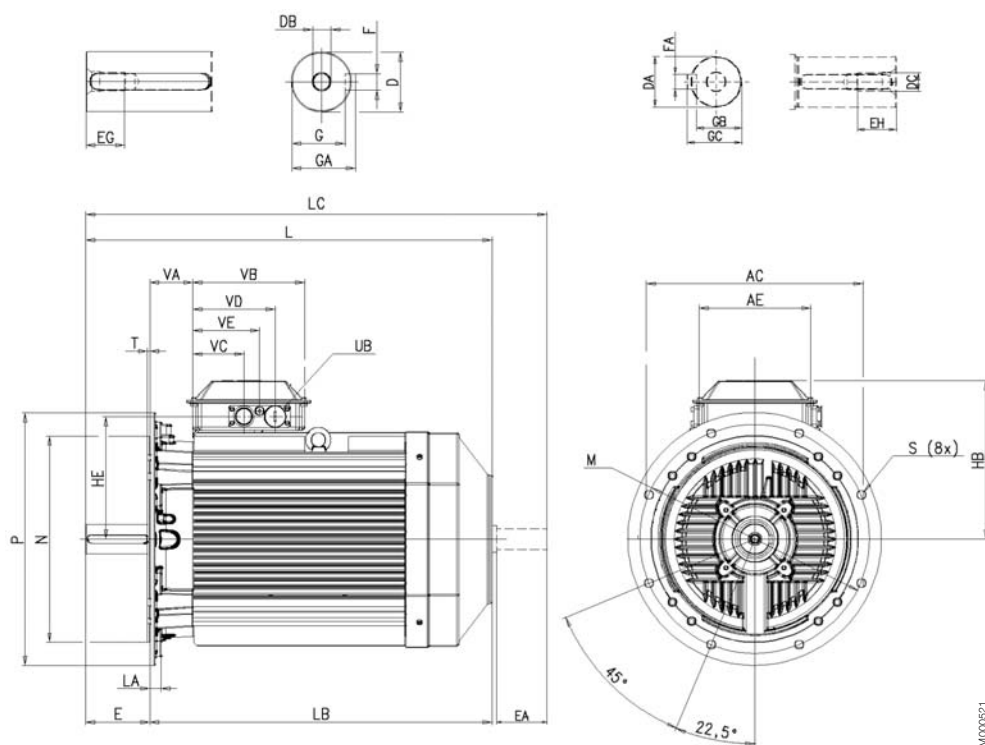

Flange-mounted motor; IM B5 (IM 3001), IM 3002

IM B5 (IM 3001), IM 3002

Motor size	Poles	AC	AE	D	DA	DB	DC	E ¹⁾	EA	EG	EH	F	FA	G	GA	GB	GC	HB ³⁾	HB ⁴⁾	HE ³⁾	HE ⁴⁾
250	2	471	243	60	55	M20	M20	140	110	42	42	18	16	53	64	49	59	344	377	268	284
250	4-8	471	243	65	55	M20	M20	140	110	42	42	18	16	58	69	49	59	344	377	268	284
280	2	471	243	65	55	M20	M20	140	110	42	42	18	16	58	69	49	59	-	377	-	284
280	4-8	471	243	75	55	M20	M20	140	110	42	42	20	16	67.5	79.5	49	59	-	377	-	284

Motor size	Poles	L	LA	LB	LC	M	N	P	S	T	UB ²⁾	VA	VB	VC ³⁾	VC ⁴⁾	VD ³⁾	VD ⁴⁾	VE ³⁾	VE ⁴⁾
250	2	884	24	744	1010	500	450	550	19	5	2×FL13	93.5	243	112	77	179	167	145	122
250	4-8	884	24	744	1010	500	450	550	19	5	2×FL13	93.5	243	112	77	179	167	145	122
280	2	884	24	744	1010	500	450	550	19	5	2×FL21	93.5	243	-	77	-	167	-	122
280	4-8	884	24	744	1010	500	450	550	19	5	2×FL21	93.5	243	-	77	-	167	-	122

Tolerances

D 55-75 ISO m6

DA 45-55 ISO k6

F, FA ISO h9

N ISO j6

¹⁾ Shoulder of shaft extension and contact surface of flange are in the same plane.

²⁾ Flange opening is provided with pipe flange FL 13, with tapped lead-in holes plugged with sealing plugs.
Single- and two-speed motors: 2 × M40 + M16.

Motors for 230VD 50Hz or 250 SMC-2, 250 SMC-4 and all 280 have pipe flange FL21 and 2 × M63 + M16

³⁾ For flange opening FL13: 2 × M40 + M16

⁴⁾ For extra large flange opening FL21: 2 × M63 + M16

Dimension drawings

Foot- and flange-mounted aluminum motors, 250 - 280

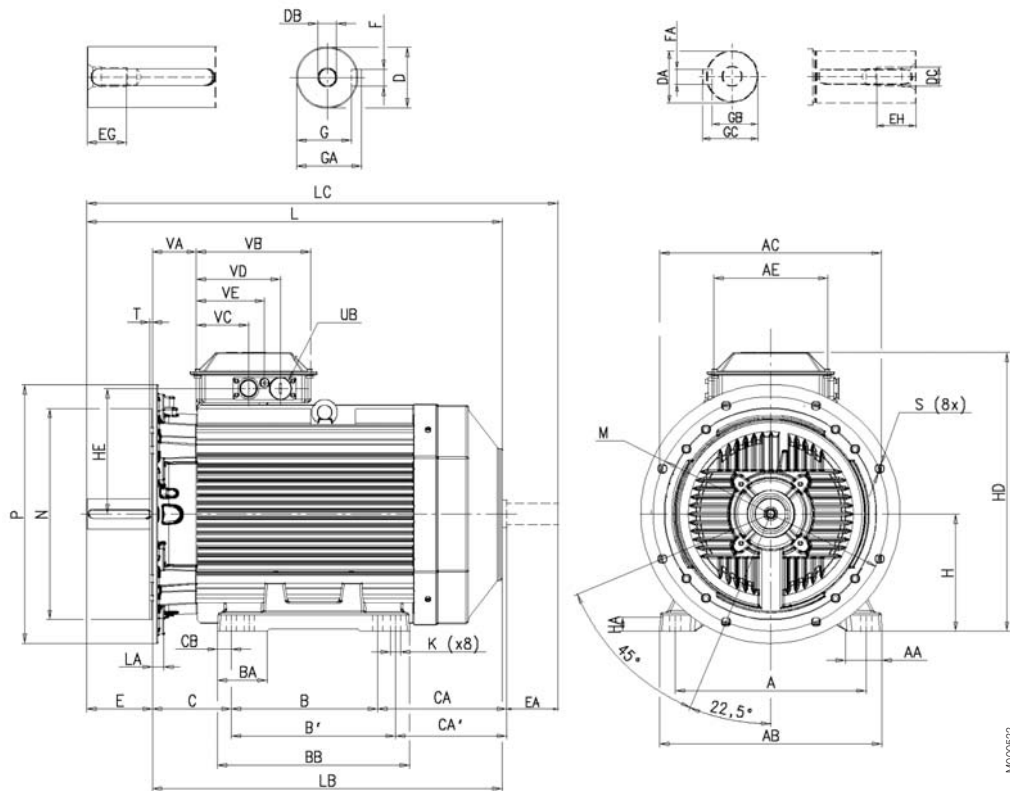

Foot- and flange-mounted motor; IM B35 (IM 2001), IM 2002

IM B35 (IM 2001), IM 2002

Motor size	Poles	A	AA	AB	AC	AE	B	B'	BA	BB	C	CA	CA'	CB	D	DA	DB	DC	E ¹⁾	EA	EG	EH	F
250	2	406	78	474	471	243	311	349	106	409	168	281	243	40	60	55	M20	M20	140	110	42	42	18
250	4-8	406	78	474	471	243	311	349	106	409	168	281	243	30	65	55	M20	M20	140	110	42	42	18
280	2	457	103	525	471	243	368	419	92	489	190	202	151	38	65	55	M20	M20	140	110	42	42	18
280	4-8	457	103	525	471	243	368	419	92	489	190	202	151	38	75	55	M20	M20	140	110	42	42	20

Motor size	Poles	FA	G	GA	GB	GC	H	HA	HD ³⁾	HD ⁴⁾	HE ³⁾	HE ⁴⁾	K	L	LA	LB	LC	M	N	P	S	T	UB ²⁾
250	2	16	53	64	49	59	250	30	594	627	268	284	22	884	24	744	1010	500	450	550	19	5	2×FL13
250	4-8	16	58	69	49	59	250	30	594	627	268	284	22	884	24	744	1010	500	450	550	19	5	2×FL13
280	2	16	58	69	49	59	280	40	-	657	-	284	24	884	24	744	1010	500	450	550	19	5	2×FL21
280	4-8	16	68	80	49	59	280	40	-	657	-	284	24	884	24	744	1010	500	450	550	19	5	2×FL21

Motor size	Poles	VA	VB	VC ³⁾	VC ⁴⁾	VD ³⁾	VD ⁴⁾	VE ³⁾	VE ⁴⁾
250	2	93	243	112	77	179	167	145	122
250	4-8	93	243	112	77	179	167	145	122
280	2	93	243	-	77	-	167	-	122
280	4-8	93	243	-	77	-	167	-	122

Tolerances	
A, B	ISO js14
C, CA	± 0.8
D 55-75	ISO m6
DA 45-55	ISO k6
F, FA	ISO h9
H	+0 -0.5
N	ISO js6

- ¹⁾ Shoulder of shaft extension and contact surface of flange are in the same plane.
- ²⁾ Flange opening is provided with pipe flange FL 13, with tapped lead-in holes plugged with sealing plugs. Single- and two-speed motors: 2 × M40 + M16. Motors for 230VD 50Hz or 250 SMC-2, 250 SMC-4 and all 280 have pipe flange FL21 and 2 × M63 + M16
- ³⁾ For flange opening FL13: 2 × M40 + M16
- ⁴⁾ For extra large flange opening FL21: 2 × M63 + M16

Accessories

Slide rails for motor sizes 160 to 280

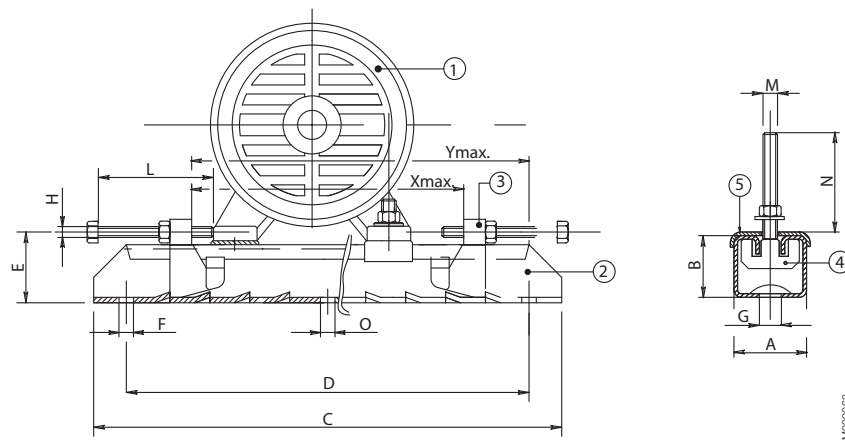

1 Motor | 2 Rail | 3 Movable adjusting bolt | 4 Fixing bolt, motor | 5 Plate

Motor size	Type	Product code 3GZV103001-	A	B	C	D	E	F	G	H	L	M	N	O	Xmax	Ymax	Weight kg
160-180	TT180/12	-14	75	42	700	630	57	17	26	M12	120	M12	50	-	520	580	12.0
200-225	TT225/16	-15	82	50	864	800	68	17	27	M16	140	M16	65	17	670	740	20.4
250-280	TT280/20	-16	116	70	1072	1000	90	20	27	M18	150	M20	80	20	870	940	43.0

¹⁾ Smaller sizes on request.

Each set includes two complete slide rails including screw for mounting the motor on the rails. Screws for mounting the rails on the foundation are not included. Slide rails are supplied with unmachined lower surfaces and should, prior to tightening down, be supported in a suitable manner.

Motors in brief

IE2/IE3 aluminum motors, sizes 63 - 132

Size	M3AA	63	71	80	90	100	112	132
Stator and end shields	Material	Die-cast aluminum alloy						
	Paint color shade	Munsell blue 8B 4.5/3.25						
	Corrosion class	C3 medium according to ISO/EN 12944-5						
Feet	Material	Integrated aluminum feet						
End shields	Material	Die-cast aluminum alloy						
	Paint color shade	Munsell blue 8B 4.5/3.25						
	Corrosion class	C3 medium according to ISO/EN 12944-5						
Bearings	D-end	6202-2Z/C3	6203-2Z/C3	6204-2Z/C3	6205-2Z/C3	6306-2Z/C3	6306-2Z/C3	6208-2Z/C3 6308-2Z/C3 (SM ₁)
	N-end	6201-2Z/C3	6202-2C/C3	6203-2Z/C3	6204-2Z/C3	6205-2Z/C3	6205-2Z/C3	6206-2Z/C3
Axially locked bearings		Locked at D-end with internal retaining ring			Locked at D-end			
Bearing seals	D-end	V-ring						
	N-end	Labyrinth seal						
Lubrication		Permanently lubricated shielded bearings						
		Grease temperature range -40 °C to +160 °C						
Measuring nipples		Not included						
Rating plate	Material	Aluminum						
Terminal box	Frame and cover	Die-cast aluminum alloy, integrated in stator						
	Corrosion class	C3 medium according to ISO/EN 12944-5						
	Cover screws	Zinc-electroplated steel						
Connections	Knock-out openings	1 × M16 × Pg11	2 × (M20 + M20)		2 × (M20+M25)		2 × (M20+M25) ¹⁾ 2 × (M40+M32+M12) ²⁾	
	Terminal box	Cable lugs, 6 terminals			6 screw terminals		Cable lugs, 6 terminals	
Fan	Material	Glass-fiber reinforced polypropylene						
Fan cover	Material	Polypropylene						
Stator winding	Material	Copper						
	Insulation	Insulation class F						
	Winding protection	Optional						
Rotor winding	Material	Die-cast aluminum						
Balancing method		Half-key balancing						
Keyway		Closed keyway						
Drain holes		Drain holes with closable plastic plugs, open on delivery						
Enclosure		IP 55						
Cooling method		IC 411						

¹⁾ Types S, SB, M, MA

²⁾ Types SC, MC, SMA - SME

Motors in brief

IE2/IE3 aluminum motors, sizes 160 - 280

Size	M3AA	160	180	200	225	250	280
Stator	Material	Die-cast aluminum alloy		Extruded aluminum alloy			
	Paint color shade	Munsell blue 8B 4.5/3.25					
	Corrosion class	C3 medium according to ISO/EN 12944-5					
Feet	Material	Separate aluminum feet		Separate cast iron feet			
End shields	Material	Cast iron					
	Paint color shade	Munsell blue 8B 4.5/3.25					
	Corrosion class	C3 medium according to ISO/EN 12944-5					
Bearings	D-end	6309-2Z/C3	6310-2Z/C3	6312-2Z/C3	6313-2Z/C3	6315-2Z/C3	6316/C3 ¹⁾
	N-end	6209-2Z/C3	6209-2Z/C3	6210-2Z/C3	6212-2Z/C3	6213-2Z/C3	6213/C3
Axially locked bearings		Locked at D-end					
Bearing seals		Axial seal at both ends					
Lubrication		Permanently lubricated shielded bearings					
		Grease temperature range -40 °C to +160 °C					
Measuring nipples		Not included					
Rating plate	Material	Aluminum					
Terminal box	Material	Die-cast aluminum alloy, integrated in stator		Deep-drawn steel sheet, bolted to stator			
	Corrosion class	C3 medium according to ISO/EN 12944-5					
	Cover screws	Zinc-electroplated steel					
Connections	Openings	(2 × M40 + M16) + (2 × M40)		2 × FL13, 2 × M40 + 1 × M16		2 × FL21	
		Type: knock-outs		Voltage code S; 2 × FL21, 2 × M63 + 1 × M16		2 × M63, 1 × M16	
	Screws	M6		M10			
	Terminal box	6 terminals for connection with cable lugs (not included)					
Fan	Material	Glass-fiber reinforced polypropylene					
Fan cover	Material	Steel					
	Paint color shade	Munsell blue 8B 4.5/3.25					
	Corrosion class	C3 medium according to ISO/EN 12944-5					
Stator winding	Material	Copper					
	Insulation	Insulation class F					
	Winding protection	3 PTC thermistors, 150 °C					
Rotor winding	Material	Die-cast aluminum					
Balancing method		Half-key balancing					
Keyway		Closed keyway					
Drain holes		Drain holes with closable plastic plugs, open on delivery					
Enclosure		IP 55					
Cooling method		IC 411					

¹⁾ 6315/C3 for 2-pole motors

For your notes

A series of horizontal dotted lines for taking notes.

For your notes

A series of horizontal dotted lines for taking notes.

Total product offering

Motors, generators and mechanical power transmission products with a complete portfolio of services



ABB is the leading manufacturer of low, medium and high voltage motors and generators, and mechanical power transmission products. ABB products are backed by a complete portfolio of services. Our in-depth knowledge of virtually every type of industrial process ensures we always specify the best solution for your needs.

> Low and high voltage IEC induction motors

- Process performance motors
- General performance motors
- High voltage cast iron motors
- Induction modular motors
- Slip-ring modular motors
- Synchronous reluctance motors

> Low and medium voltage NEMA motors

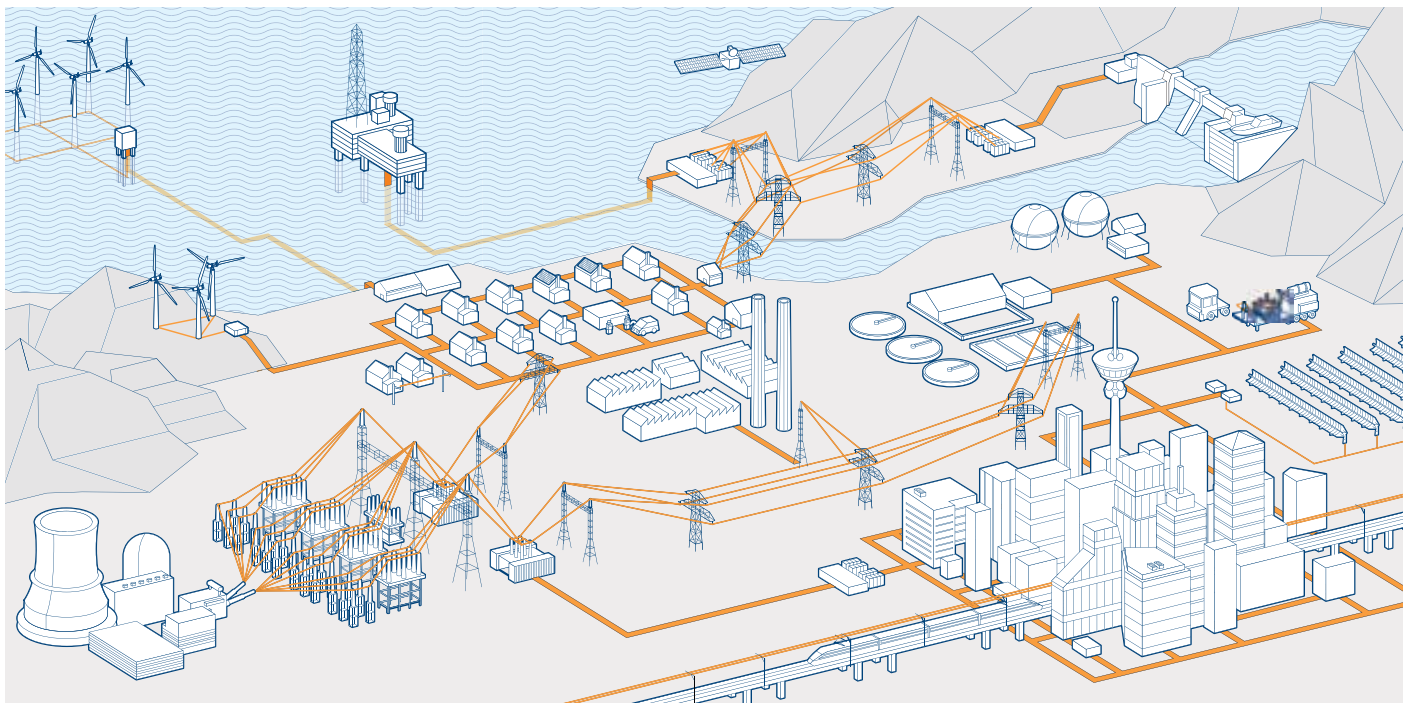
- Steel frame open drip proof (ODP) motors
- Weather protected, water cooled, fan ventilated
- Cast iron frame (TEFC)
- Air to air cooled (TEAAC) motors

> Motors and generators for explosive atmospheres

- IEC and NEMA motors and generators, for all protection types

> Synchronous motors

> Synchronous generators

- Synchronous generators for diesel and gas engines
- Synchronous generators for steam and gas turbines

> Wind power generators

> Generators for small hydro

> Other motors and generators

- Brake motors
- DC motors and generators
- Gear motors
- Marine motors and generators
- Single phase motors
- Motors for high ambient temperatures
- Permanent magnet motors and generators
- High speed motors
- Smoke extraction motors

- Wash down motors
- Water cooled motors
- Generator sets
- Roller table motors
- Low inertia motors
- Traction motors and generators

> Life cycle services

- Installation and commissioning
- Spares and consumables
- Preventive maintenance
- Predictive maintenance
- Condition monitoring
- On-site and workshop
- Remote troubleshooting
- Technical support
- Engineering and consulting
- Extensions, upgrades and retrofits
- Replacements
- Training
- Service agreements

> Mechanical power transmission components, bearings, gearings

Life cycle services and support

From pre-purchase to migration and upgrades

ABB offers a complete portfolio of services to ensure trouble-free operation and long product lifetimes. These services cover the entire life cycle. Local support is provided through a global network of ABB service centers and certified partners.

Pre-purchase

ABB's front-end sales organization can help customers to quickly and efficiently select, configure and optimize the right motor or generator for their application.

Installation and commissioning

Professional installation and commissioning by ABB's certified engineers represent an investment in availability and reliability over the entire life cycle.

Engineering and consulting

ABB's experts provide energy efficiency and reliability appraisals, advanced condition and performance assessments and technical studies.

Condition monitoring and diagnosis

Unique services collect and analyze data to provide early warnings of problems before failures can occur. All critical areas of the equipment are covered.

Maintenance and field services

ABB offers life cycle management plans and preventive maintenance products. The recommended four-level maintenance program covers the entire product lifetime.

Spare parts

Spare parts and support are offered throughout the life cycle of ABB products. In addition to individual spares, tailored spare part packages are also available.

Repair and refurbishment

Support for all ABB motors and generators and other brands is provided by ABB's global service organization. Specialist teams can also deliver emergency support.

Migration and upgrades

Life cycle audits determine the optimum upgrades and migration paths. Upgrades range from individual components to direct replacement motors and generators.

Training

Product and service training courses take a practical approach. The training ranges from standard courses to specially tailored programs to suit customer requirements.

Specialized support

Specialized support is offered through ABB's global service organization. Local units provide major and minor repairs as well as overhauls and reconditioning.

Service contracts

Service contracts are tailored to the customer's needs. The contracts combine ABB's entire service portfolio and 120 years of experience to deploy the optimal service practices.



Contact us

www.abb.com/motors&generators

We reserve the right to make technical changes or modify the contents of this document without prior notice. With regard to purchase orders, the agreed particulars shall prevail. ABB does not accept any responsibility what so ever for potential errors or possible lack of information in this document.

We reserve all rights in this document and in the subject matter and illustrations contained herein. Any reproduction, disclosure to third parties or utilization of its contents – in whole or in parts – is forbidden without prior written consent of ABB.

© Copyright 2014 ABB.
All rights reserved.

9AKK105944 AU-EN 05-2014