

## YLP 10-1000-23 POMPA LOBE PUMP

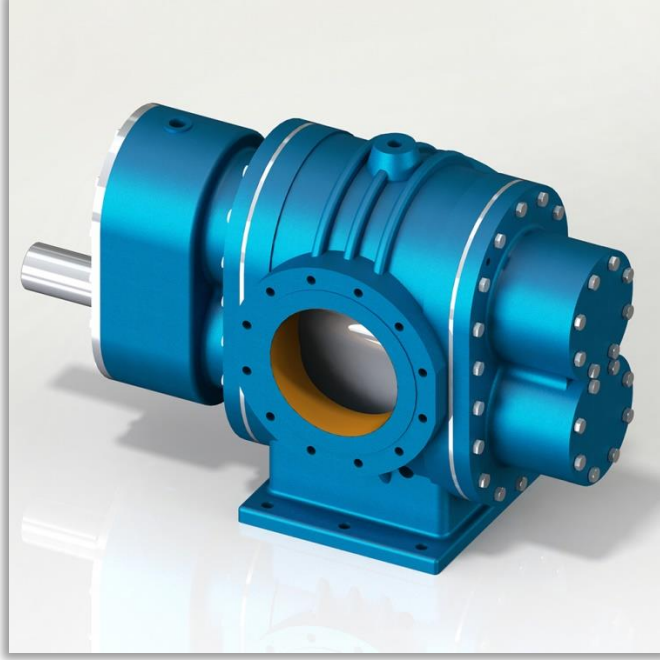

POMPA DEĞERLERİ / PUMP PROPERTIES	
Q	:300 m <sup>3</sup> /h
Hm	:1 ~ 7 Bar
T	:0 ~ 150 °C
n	:1 ~ 230 d/d
Visc.	:150 ~ 500000 SSU

### KULLANIM ALANLARI

- Gıda Sanayinde (Çikolata, Şeker Şurubu, Krema, Melas...)
- Kimya Sanayinde (İlaç, Deterjan, Sabun, Kozmetik kremler...)
- Boya Sanayinde
- Kağıt Sanayinde
- Jeller, Gres...

### USE AREAS

- *Food Industry (Chocolate, Sugar Syrup, Cream, Molasses)*
- *Chemical Industry (Drugs, Detergents, Soap, Cosmetic creams...)*
- *Paint Industry*
- *Pulp & Paper Industry*
- *Gels, Greases...*

### MALZEME SEÇENEKLERİ

- Pompa Gövdesi ve Kapaklar: Pik.
- Loblar: Çelik döküm, paslanmaz AISI 304 / 316 döküm
- Yataklar : Rulman
- Sızdırmazlık: Özel keçe

### MATERIAL OPTIONS

- *Pump Body and Covers:Cast iron.*
- *Lobes: Steel cast, stainless AISI 304 / 316 cast.*
- *Bearings: Bearing*
- *Sealing: Special seal*

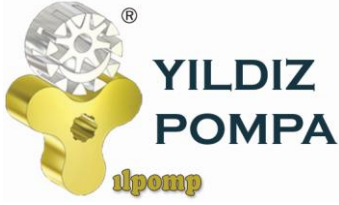

## YLP 10-1000-23 POMPA LOBE PUMP



### LOP POMPA ÇALIŞMA PRENSİBİ / WORKING PRINCIPLE OF LOBE PUMP

Lob Pompalar, Zamanlama Dişlileri tarafından tahrik edilmektedir. Söz konusu Zamanlama Dişlileri sayesinde, paralel miller üzerinde bulunan ve tamamen paslanmaz çelikten imal edilen Gövde'nin içerisinde birbirine veya gövde ile lob arasında temas etmeden dönmesini sağlamaktadır. Pompanın tahriki ise redüktörden alınan dönme hareketi, döndüren zamanlama dişlisinden döndürülen zamanlama dişlisine ters yönde aktararak sağlanmaktadır.

Lob Pompaların hijyenik malzeme ve tasarımından dolayı güvenilirlik sağlayabilir, sıvının yapısını bozmadan transfer edebilir ve sıvının viskozitesine bağlı olmak üzere, 12 Bar'a kadar basınç elde edebilmektedir.

*Rotary Lobe Pumps, are driven by Timing Gears. Rotor lobes, which are located on two parallel shafts in a stainless steel casing, are prevented from physical contact with each other and/or with inner surface of casing by timing gears. Rotational motion received from driver's shaft are transferred in the opposite direction to pump's driven timing gear by driving timing gear.*

*Rotary Lobe Pumps are reliable thanks to its hygiene design, capable of pumping without damaging liquid's structure, and depending on liquid's viscosity, Rotary Lobe Pumps have the ability of generating pressure up to 12 Bar.*

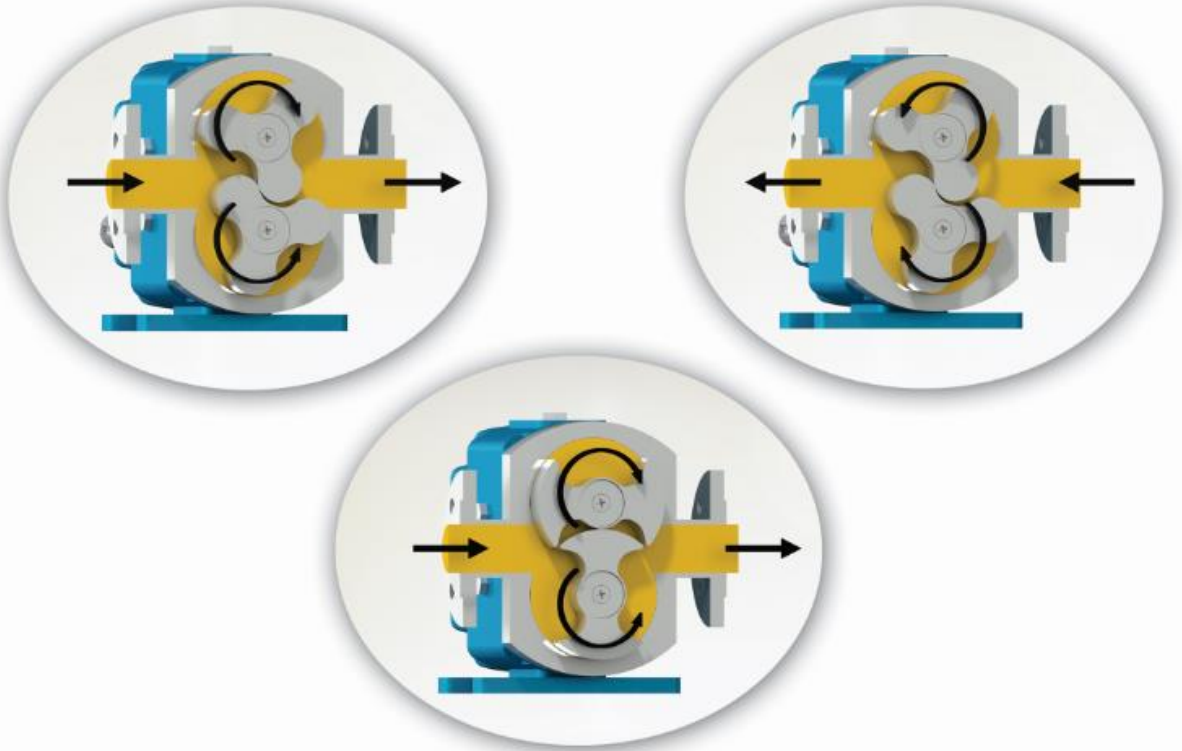

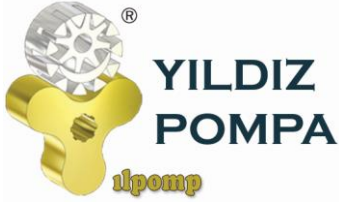

## YLP 10-1000-23 POMPA LOBE PUMP

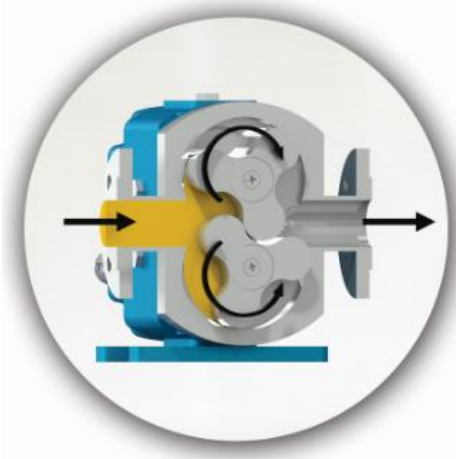

Yandaki renkli kısım sıvının pompa gövdesindeki emiş ağız alanına, çeviren ve çevrilen dış dişlilerin sayesinde lob boşlukları alanına girişini gösterir. Siyah oklar pompanın dönüş ve sıvının ilerleyişini gösterir.

*Colored area in the picture on the side presents liquid while entering suction port, due to vacuum created by rotation of lobes; which are rotated by timing gears. Arrows in black indicates forward advancing of the liquid and rotation direction of the pump.*

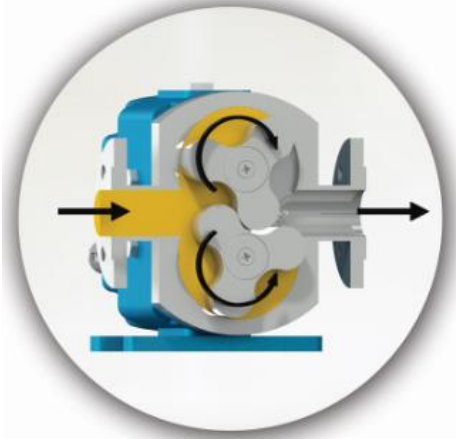

Görüldüğü gibi akışkan taşınması loblar ile lobları içinde barındıran gövde arasında olmaktadır. Akışkan loblar arasından geçmemektedir.

*Picture here presents liquid filling inner chamber of the pump and just before reaching to discharge port. Here we can also see how a closed area is formed between rotor/lobe and casing.*

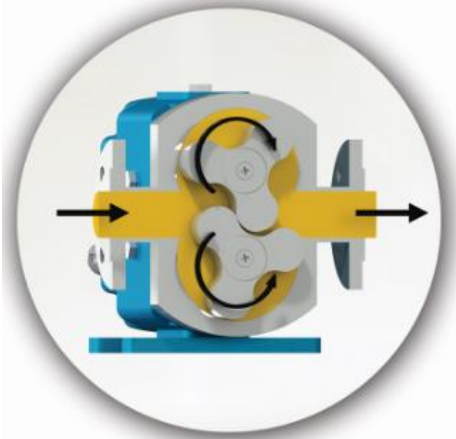

Lob ve lob gövdesi arasındaki boşlukların sıvı için nasıl bir kapalı cep oluşturduğunu görebiliyoruz. Bu görüntü pompanın tamamen dolup taşıdığı durumu ve sıvının boşaltma işlemini, boşaltma ağızından ilerleyişini göstermektedir. Sonunda lobların gücü ile akışkan basınç altında çıkış ağızına iletilir.

*In this picture, we can see how inner chamber of pump is completely filled, how liquid have reached outlet port and now overflowing outside the pump. As a final step, liquid is forced under pressure to outlet port by power generated by rotation of lobes/rotors.*



## YLP 10-1000-23 POMPA LOBE PUMP



### POMPA BOYUT ÖLÇÜLERİ / PUMP DIMENSIONS

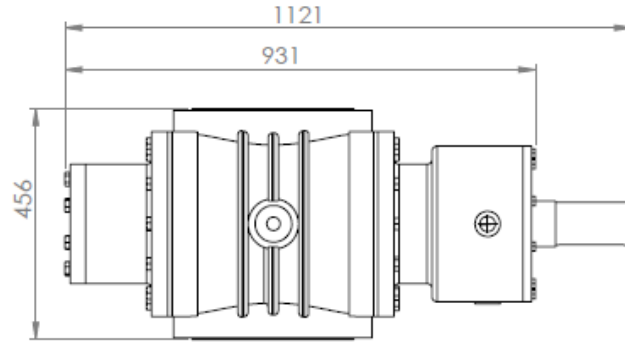
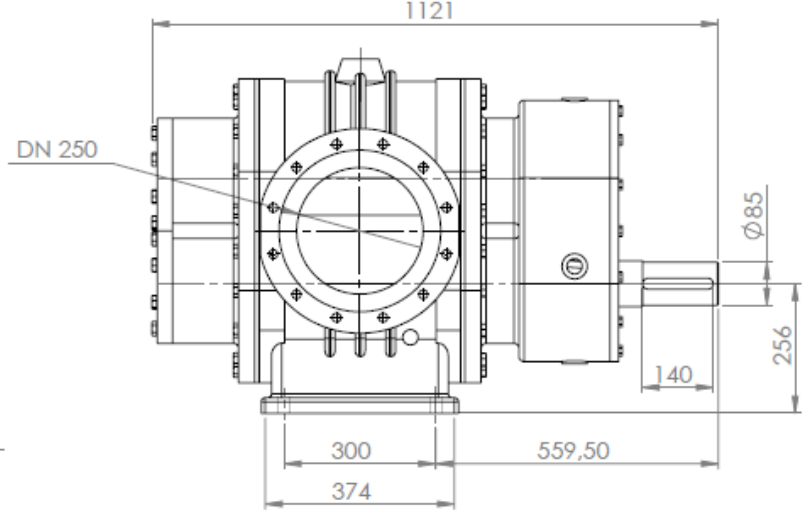
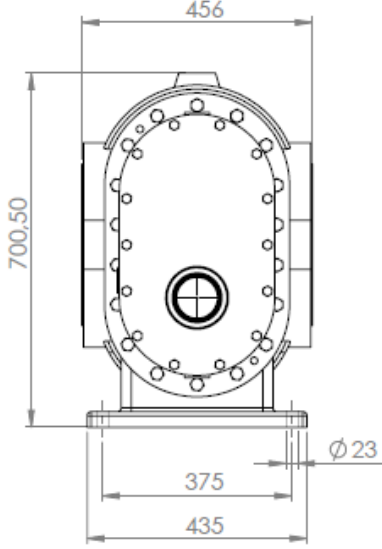

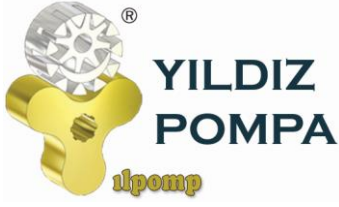

## YLP 10-1000-23 POMPA LOBE PUMP

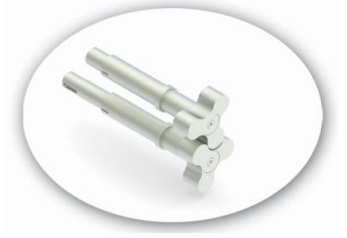

### AKUPLAJ ÖLÇÜLERİ / COUPLING DIMENSIONS REDÜKTÖR AKUPELİ / GEARBOX DRIVE

45 kw 60 d/d (rpm) İMAK-İRAN123-225M 315C KAPLİN

