



MLFB-Ordering data: 1LE1002-1BB22-2AA4

Motor type: 1AV1112B

Client order no.:

Order no.:

Offer no.:

Remarks:

Item no.:

Consignment no.:

Project:

U [V]	Δ / Y	f [Hz]	P [kW]	P [hp]	I [A]	n [1/min]	M [Nm]	NOM. EFF at ... load [%]			Power factor at ... load			I _A /I _N I _f /I _N	M _A /M _N T _f /T _N	M _K /M _N T _B /T _N	IE-CL
								4/4	3/4	2/4	4/4	3/4	2/4				
230	Δ	50	4.00	- / -	14.60	1435	27.0	83.1	84.3	84.0	0.83	0.77	0.65	6.1	2.5	2.9	IE1
400	Y	50	4.00	- / -	8.40	1435	27.0	83.1	84.3	84.0	0.83	0.77	0.65	6.1	2.5	2.9	IE1
460	Y	60	4.55	- / -	8.10	1735	25.0	85.0	86.1	85.1	0.83	0.78	0.66	6.8	2.5	3.2	IE1
IM B3 / IM 1001			FS 112 M		27 kg	IP55	IEC/EN 60034			IEC, DIN, ISO, VDE, EN							

Mechanical data

Sound pressure level 50Hz/60Hz (load)	58 dB(A) ¹⁾	62 dB(A) ¹⁾
Moment of inertia	0.01 kg m ²	
Bearing DE NDE	6206 2Z C3	6206 2Z C3
Bearing lifetime	40000 h	
Lubricants	Esso Unirex N3	
Regreasing device	No	
Grease nipple	- / -	
Type of bearing	Preloaded bearing DE	
Condensate drainage holes	No	
External earthing terminal		
Vibration severity grade	A	
Insulation	155(F) to 130(B)	
Duty type	S1	
Direction of rotation	bidirectional	
Frame material	aluminum	
Data of anti condensation heating	-/-	
Coating (paint finish)	Standard paint finish C2	
Color, paint shade	RAL7030	
Motor protection	(A) without (Standard)	
Method of cooling	IC411 - self ventilated, surface cooled	

Environmental conditions

Ambient temperature	-20 °C - +40 °C
Altitude above sea level	1000 m

Notes

I_A¹⁾ = locked rotor current / current nominal M_K/M_N = break down torque / nominal torque
M_A/M_N = locked rotor torque / torque nominal 1) Value is valid only for DOL operation with motor design IC411

Terminal box

Terminal box position	top
Material of terminal box	Aluminium
Type of terminal box	TB1 F00
Contact screw thread	M4
Max. cross-sectional area	4.0 mm ²
Cable diameter from ... to ...	11.0 mm - 21.0 mm
Cable entry	2xM32x1,5
Cable gland	2 plugs

Special design (0)

Tel: 48 0000 49 (60 Lines)

Confidencial, reproducción, disseminación y/o edición de este documento así como su utilización en otros proyectos sin autorización expresa de Siemens AG. Reservados todos los derechos. /
 Vertraulich, Vervielfältigung, Verbreitung, Weitergabe und/oder Bearbeitung dieses Dokuments, sowie die Nutzung dieses Dokuments in anderen Projekten ohne schriftliche Genehmigung von Siemens AG. Alle Rechte vorbehalten. /
 Tous droits réservés. Toute réimpression, reproduction ou utilisation de ce document sans autorisation écrite de Siemens AG est formellement interdite. /
 Todos los derechos reservados. Toda reproducción o uso no autorizado de este documento sin el consentimiento escrito de Siemens AG quedan expresamente prohibidos. /
 Copyright © Siemens AG 2018. All rights reserved. /
 Confidantiale, verspreiden, verspreiden en/of verspreiden van dit document, evenals het gebruik van dit document in andere projecten, is zonder schriftelijke toestemming van Siemens AG uitdrukkelijk verboden. /
 Vertraulich, Vervielfältigung, Verbreitung, Weitergabe und/oder Bearbeitung dieses Dokuments, sowie die Nutzung dieses Dokuments in anderen Projekten ohne schriftliche Genehmigung von Siemens AG. Alle Rechte vorbehalten. /
 Tous droits réservés. Toute réimpression, reproduction ou utilisation de ce document sans autorisation écrite de Siemens AG est formellement interdite. /
 Todos los derechos reservados. Toda reproducción o uso no autorizado de este documento sin el consentimiento escrito de Siemens AG quedan expresamente prohibidos. /
 Copyright © Siemens AG 2018. All rights reserved. /
 Confidantiale, verspreiden, verspreiden en/of verspreiden van dit document, evenals het gebruik van dit document in andere projecten, is zonder schriftelijke toestemming van Siemens AG uitdrukkelijk verboden.

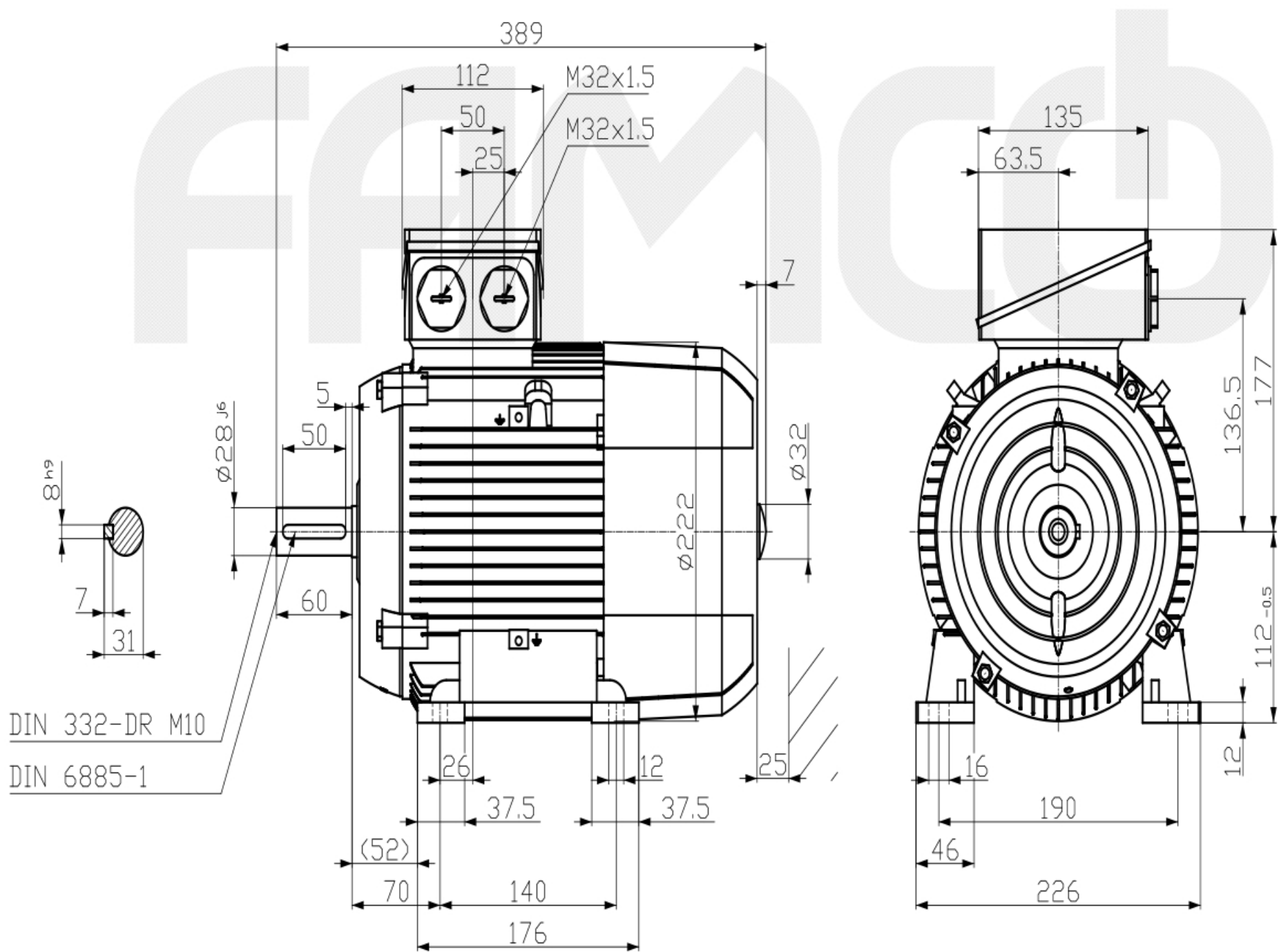

Tel: 48 0000 49 (60 Lines)

Tolerance	Surface	Material	Weight	Scale
1LE1002-1BB22-2AA4	Author	Dimensional drawing		
	Creator	DTK	Maßzeichnung	
	Approval			
	Department			
	Change Order	MFB	Doc. Type	
	Doc. State	1/21/19	Item No.	Page Size A3
	Revision	Index RS	Doc. No.	1st Language en 2nd Language de
© Siemens AG 2018	Project No.	-	Ref. No.	Sheet 1 of 1