



MLFB-Ordering data: 1LE1002-1BC22-2FA4

Motor type: 1AV1112C

Client order no.:

Order no.:

Offer no.:

Remarks:

Item no.:

Consignment no.:

Project:

U [V]	Δ / Y	f [Hz]	P [kW]	P [hp]	I [A]	n [1/min]	M [Nm]	NOM. EFF at ... load [%]			Power factor at ... load			I_A/I_N I_f/I_N	M_A/M_N T_f/T_N	M_K/M_N T_B/T_N	IE-CL
								4/4	3/4	2/4	4/4	3/4	2/4				
230	Δ	50	2.20	- / -	9.90	940	22.0	77.7	78.4	76.6	0.72	0.64	0.51	4.6	2.6	2.7	IE1
400	Y	50	2.20	- / -	5.70	940	22.0	77.7	78.4	76.6	0.72	0.64	0.51	4.6	2.6	2.7	IE1
460	Y	60	2.54	- / -	5.60	1140	21.0	78.5	79.2	77.8	0.73	0.65	0.53	5.1	2.6	2.8	IE1
IM B5 / IM 3001			FS 112 M			25 kg	IP55	IEC/EN 60034			IEC, DIN, ISO, VDE, EN						

Mechanical data

Sound pressure level 50Hz/60Hz (load)	57 dB(A) ¹⁾ 60 dB(A) ¹⁾
Moment of inertia	0.0092 kg m ²
Bearing DE NDE	6206 2Z C3 6206 2Z C3
Bearing lifetime	40000 h
Lubricants	Esso Unirex N3
Regreasing device	No
Grease nipple	- / -
Type of bearing	Preloaded bearing DE
Condensate drainage holes	No
External earthing terminal	
Vibration severity grade	A
Insulation	155(F) to 130(B)
Duty type	S1
Direction of rotation	bidirectional
Frame material	aluminum
Data of anti condensation heating	-/-
Coating (paint finish)	Standard paint finish C2
Color, paint shade	RAL7030
Motor protection	(A) without (Standard)
Method of cooling	IC411 - self ventilated, surface cooled

Environmental conditions

Ambient temperature	-20 °C - +40 °C
Altitude above sea level	1000 m

Notes

I_A/I_N = locked rotor current / current nominal M_K/M_N = break down torque / nominal torque
 M_A/M_N = locked rotor torque / torque nominal 1) Value is valid only for DOL operation with motor design IC411

Terminal box

Terminal box position	top
Material of terminal box	Aluminium
Type of terminal box	TB1 F00
Contact screw thread	M4
Max. cross-sectional area	4.0 mm ²
Cable diameter from ... to ...	11.0 mm - 21.0 mm
Cable entry	2xM32x1,5
Cable gland	2 plugs

Special design (0)

Transmittal, reproduction, dissemination and/or editing of this document as well as utilization of its contents and communication thereof to others without express authorization are prohibited. Offenders will be held liable for any damages caused by their actions. Patent, trademark, copyright or registration of a utility model or design patent are reserved.

Weitergabe sowie Vervielfältigung, Verbreitung und/oder Bearbeitung dieses Dokuments, Verwertung und Mitteilung seines Inhaltes sind verboten, soweit nicht ausdrücklich gestattet. Zuwiderhandlungen verpflichten zu Schadenersatz. Alle Rechte vorbehalten. Gebrauchsmuster-, Marken- oder Geschmackschutzrechte sind vorbehalten.

Confidencial e secreto. Vervielfältigung, Verbreitung und/oder Bearbeitung dieses Dokuments, Verwertung und Mitteilung seines Inhaltes sind verboten, soweit nicht ausdrücklich gestattet. Zuwiderhandlungen verpflichten zu Schadenersatz. Alle Rechte vorbehalten. Gebrauchsmuster-, Marken- oder Geschmackschutzrechte sind vorbehalten.

Confidencial e secreto. Vervielfältigung, Verbreitung und/oder Bearbeitung dieses Dokuments, Verwertung und Mitteilung seines Inhaltes sind verboten, soweit nicht ausdrücklich gestattet. Zuwiderhandlungen verpflichten zu Schadenersatz. Alle Rechte vorbehalten. Gebrauchsmuster-, Marken- oder Geschmackschutzrechte sind vorbehalten.

Confidencial e secreto. Vervielfältigung, Verbreitung und/oder Bearbeitung dieses Dokuments, Verwertung und Mitteilung seines Inhaltes sind verboten, soweit nicht ausdrücklich gestattet. Zuwiderhandlungen verpflichten zu Schadenersatz. Alle Rechte vorbehalten. Gebrauchsmuster-, Marken- oder Geschmackschutzrechte sind vorbehalten.

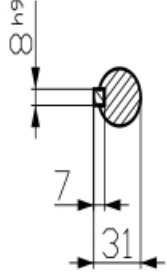

DIN 332-DR M10
DIN 6885-1

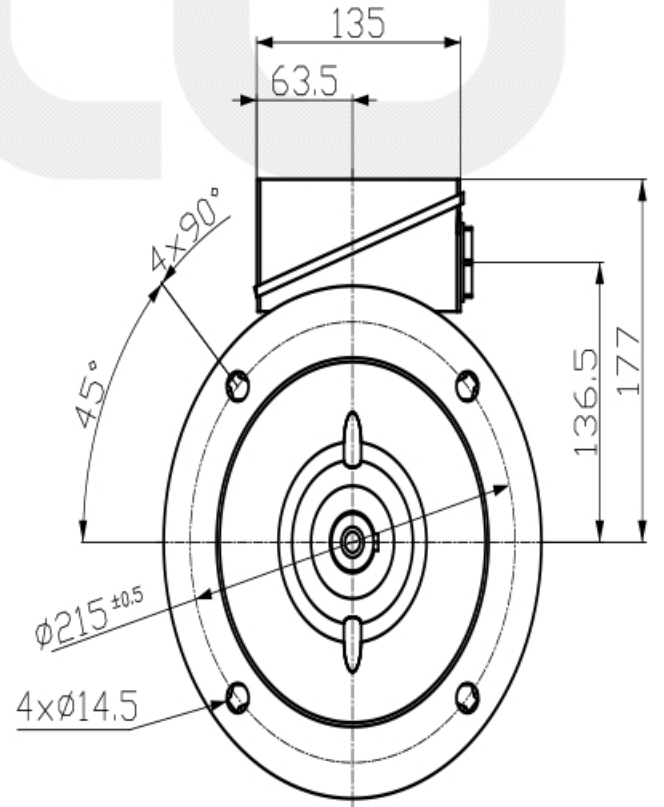
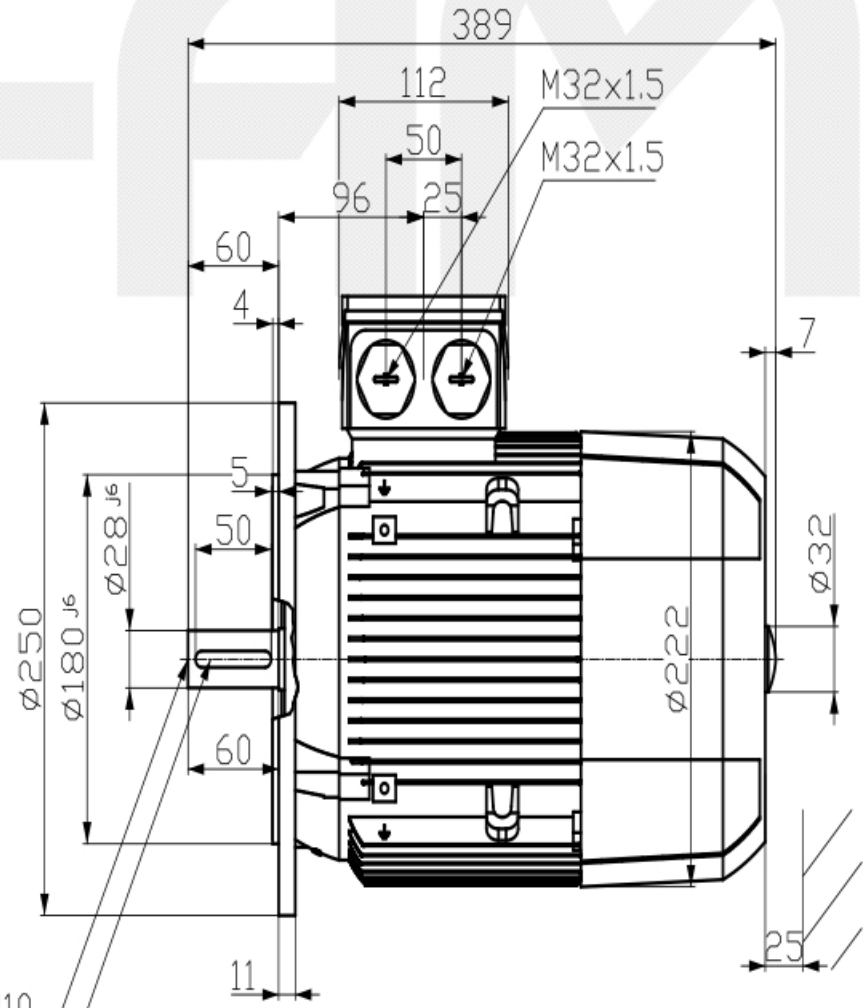

Tel: 48 0000 49 (60 Lines)

Tolerance	Surface	Material	Weight	Scale	
1LE1002-1BC22-2FA4	Author	Dimensional drawing Maßzeichnung	-	mm	
-	Creator				DTK
	Approval				
	Department				
	Change Order	MFB	Doc. Type		
	Doc. State	1/19/19	Item No.	Page Size A3	
	Revision	Index RS	Doc. No.	1st Language en 2nd Language de	
© Siemens AG 2018	Project No.	-	Ref. No.	Sheet 1 of 1	