



MLFB-Ordering data: 1LE1002-1CC23-4AA4

Motor type: 1AV1132C

Client order no.:

Order no.:

Offer no.:

Remarks:

Item no.:

Consignment no.:

Project:

U [V]	Δ / Y	f [Hz]	P [kW]	P [hp]	I [A]	n [1/min]	M [Nm]	NOM. EFF at ... load [%]			Power factor at ... load			I _A /I _N I _f /I _N	M _A /M _N T _f /T _N	M _K /M _N T _B /T _N	IE-CL
								4/4	3/4	2/4	4/4	3/4	2/4				
400	Δ	50	4.00	- / -	9.30	955	40.0	81.4	82.5	81.9	0.76	0.69	0.57	5.2	2.3	2.6	IE1
690	Y	50	4.00	- / -	5.40	955	40.0	81.4	82.5	81.9	0.76	0.69	0.57	5.2	2.3	2.6	IE1
460	Δ	60	4.55	- / -	8.90	1155	38.0	83.5	84.6	83.9	0.77	0.71	0.59	5.6	2.3	2.7	IE1
IM B3 / IM 1001		FS 132 M		39 kg		IP55		IEC/EN 60034			IEC, DIN, ISO, VDE, EN						

Mechanical data

Sound pressure level 50Hz/60Hz (load)	63 dB(A) ¹⁾	67 dB(A) ¹⁾
Moment of inertia	0.021 kg m ²	
Bearing DE NDE	6208 2Z C3	6208 2Z C3
Bearing lifetime	40000 h	
Lubricants	Esso Unirex N3	
Regreasing device	No	
Grease nipple	- / -	
Type of bearing	Preloaded bearing DE	
Condensate drainage holes	No	
External earthing terminal		
Vibration severity grade	A	
Insulation	155(F) to 130(B)	
Duty type	S1	
Direction of rotation	bidirectional	
Frame material	aluminum	
Data of anti condensation heating	-/-	
Coating (paint finish)	Standard paint finish C2	
Color, paint shade	RAL7030	
Motor protection	(A) without (Standard)	
Method of cooling	IC411 - self ventilated, surface cooled	

Environmental conditions

Ambient temperature	-20 °C - +40 °C
Altitude above sea level	1000 m

Notes

I_A¹⁾ = locked rotor current / current nominal M_K/M_N = break down torque / nominal torque
M_A/M_N = locked rotor torque / torque nominal 1) Value is valid only for DOL operation with motor design IC411

Terminal box

Terminal box position	top
Material of terminal box	Aluminium
Type of terminal box	TB1 H00
Contact screw thread	M4
Max. cross-sectional area	6.0 mm ²
Cable diameter from ... to ...	11.0 mm - 21.0 mm
Cable entry	2xM32x1,5
Cable gland	2 plugs

Special design (0)

Tel: 48 0000 49 (60 Lines)

Confidantia a titre de secret d'entreprise. Tous droits réservés. Communicado como secreto empresarial. Reservados todos los derechos. Dosepewnta a kawatce mroweozoutome weero oeperta. Confiado como secreto de empresa. Nos reservamos todos los derechos.

Transmittal, reproduction, dissemination and/or editing of this document as well as utilization of its contents and communication thereof to others without express authorization are prohibited. Offenders will be held liable for damages. Patent rights are reserved.

Weitergabe sowie Vervielfältigung, Verbreitung und/oder Bearbeitung dieses Dokuments, Verwertung und Mitteilung seines Inhaltes sind verboten, soweit nicht ausdrücklich gestattet. Zuwiderhandlungen verpflichten zu Schadenersatz. Alle Rechte vorbehalten.

Confidencial, reproducción, dissemination and/or editing of this document as well as utilization of its contents and communication thereof to others without express authorization are prohibited. Offenders will be held liable for damages. Patent rights are reserved.

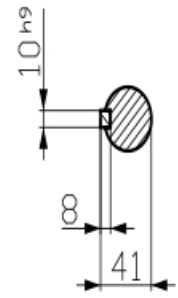

DIN 332-DR M12
DIN 6885-1

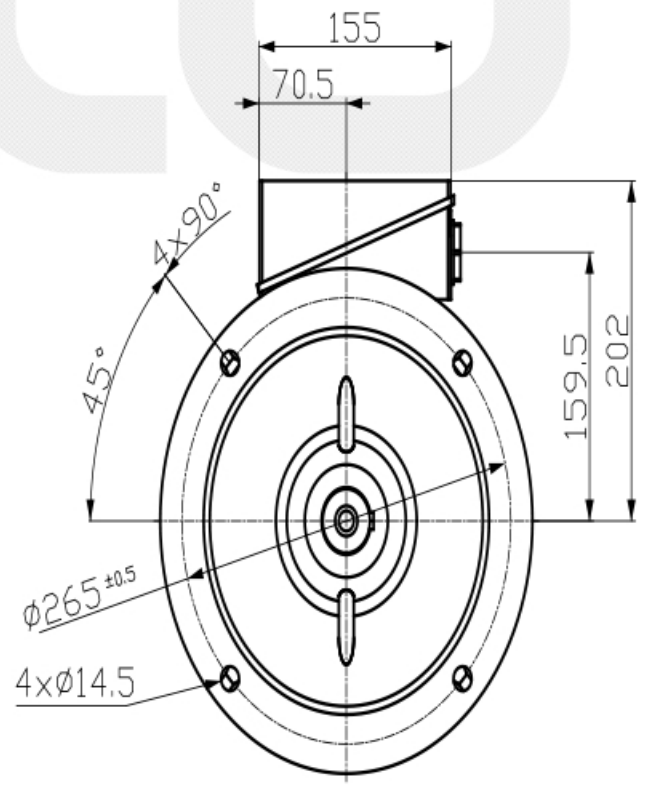
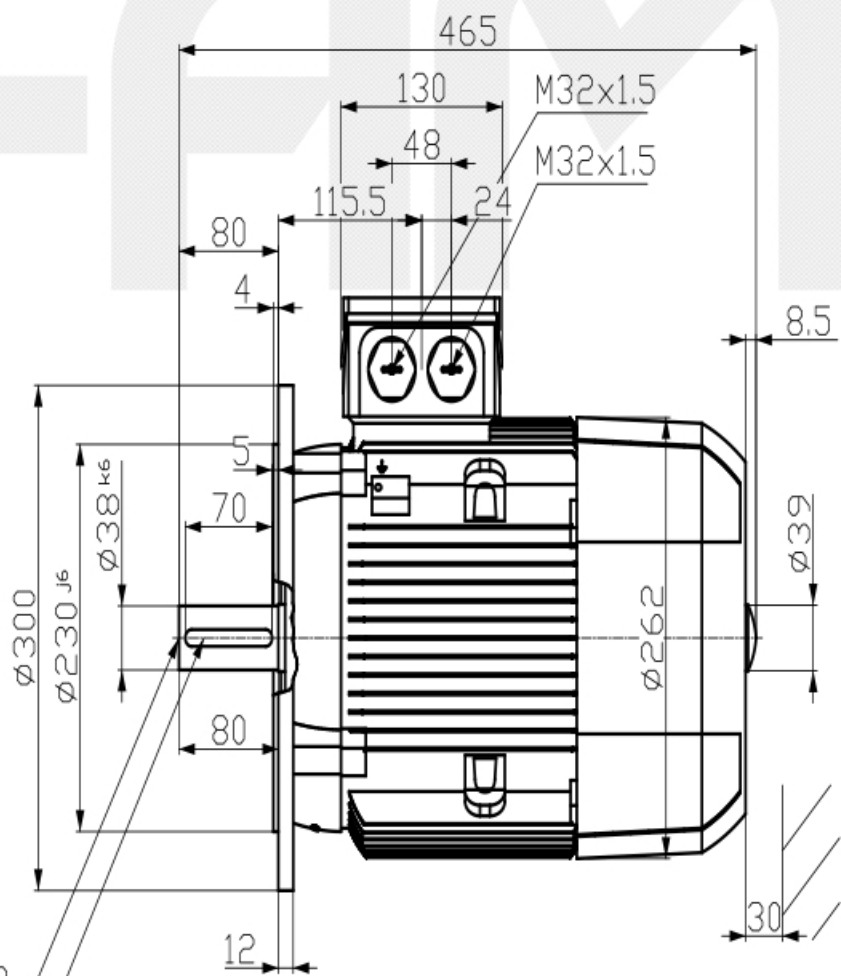

Tel: 48 0000 49 (60 Lines)

Tolerance	Surface	Material	Weight	Scale
			-	mm
1LE1002-1CC03-4FA4	Author	Dimensional drawing		
	Creator	Maßzeichnung		
	Approval	DTK		
	Department			
	Change Order	MFB	Doc. Type	
	Doc. State	1/21/19	Item No	Page Size A3
	Revision	Inden IS	Doc. No	1st Language en
				2nd Language de
© Siemens AG 2018	Project No	-	Ref No	Sheet 1 of 1