



MLFB-Ordering data: 1LE1002-1DC23-4AA4

Motor type: 1AV1162C

Client order no.:

Order no.:

Offer no.:

Remarks:

Item no.:

Consignment no.:

Project:

U [V]	Δ / Y	f [Hz]	P [kW]	P [hp]	I [A]	n [1/min]	M [Nm]	NOM. EFF at ... load [%]			Power factor at ... load			I _A /I _N I _f /I _N	M _A /M _N T _f /T _N	M _K /M _N T _B /T _N	IE-CL
								4/4	3/4	2/4	4/4	3/4	2/4				
400	Δ	50	7.50	- / -	17.50	970	74.0	84.7	84.8	83.2	0.73	0.66	0.54	5.5	2.1	2.9	IE1
690	Y	50	7.50	- / -	10.10	970	74.0	84.7	84.8	83.2	0.73	0.66	0.54	5.5	2.1	2.9	IE1
460	Δ	60	8.60	- / -	16.70	1170	70.0	86.0	86.0	84.5	0.75	0.68	0.57	5.9	2.2	2.9	IE1
IM B3 / IM 1001			FS 160 M		72 kg	IP55	IEC/EN 60034		IEC, DIN, ISO, VDE, EN								

Mechanical data

Sound pressure level 50Hz/60Hz (load)	67 dB(A) ¹⁾ 70 dB(A) ¹⁾
Moment of inertia	0.056 kg m ²
Bearing DE NDE	6209 2Z C3 6209 2Z C3
Bearing lifetime	40000 h
Lubricants	Esso Unirex N3
Regreasing device	No
Grease nipple	- / -
Type of bearing	Locating bearing NDE
Condensate drainage holes	No
External earthing terminal	
Vibration severity grade	A
Insulation	155(F) to 130(B)
Duty type	S1
Direction of rotation	bidirectional
Frame material	aluminum
Data of anti condensation heating	-/-
Coating (paint finish)	Standard paint finish C2
Color, paint shade	RAL7030
Motor protection	(A) without (Standard)
Method of cooling	IC411 - self ventilated, surface cooled

Environmental conditions

Ambient temperature	-20 °C - +40 °C
Altitude above sea level	1000 m

Notes

I_A¹⁾/I_N = locked rotor current / current nominal M_K/M_N = break down torque / nominal torque
M_A/M_N = locked rotor torque / torque nominal 1) Value is valid only for DOL operation with motor design IC411

Terminal box

Terminal box position	top
Material of terminal box	Aluminium
Type of terminal box	TB1 J00
Contact screw thread	M5
Max. cross-sectional area	16.0 mm ²
Cable diameter from ... to ...	19.0 mm - 28.0 mm
Cable entry	2xM40x1,5
Cable gland	2 plugs

Special design (0)

Tel: 48 0000 49 (60 Lines)

Confidencial, reproducción, disseminación o uso no autorizado de este documento es prohibido. Reservados todos los derechos. No se permite la explotación económica ni la transformación de esta obra. Queda permitida la impresión en su totalidad.

Transmittal, reproduction, dissemination and/or editing of this document as well as utilization of its contents and communication thereof to others without express authorization are prohibited. Offenders will be held liable for any damages. All rights reserved. No part of this document may be reproduced or transmitted in any form or by any means electronic or mechanical, including photocopying and recording, or by any information storage or retrieval system, without express prior written permission from Siemens AG.

Mehrsprachige sowie Übersetzung, Verbreitung und/oder Bearbeitung dieses Dokuments, Verwertung und Mitteilung seines Inhaltes sind verboten, soweit nicht ausdrücklich gestattet. Zuwiderhandlungen verpflichten zu Schadenersatz. Alle Rechte vorbehalten.

Confidencial como secreto de empresa. Reservados todos los derechos. No se permite la explotación económica ni la transformación de esta obra. Queda permitida la impresión en su totalidad.

Confidantiale als geheime informatie. Alle rechten voorbehouden. Het verspreiden van de inhoud van dit document is niet toegestaan.

Confidantiale als geheime informatie. Alle rechten voorbehouden. Het verspreiden van de inhoud van dit document is niet toegestaan.

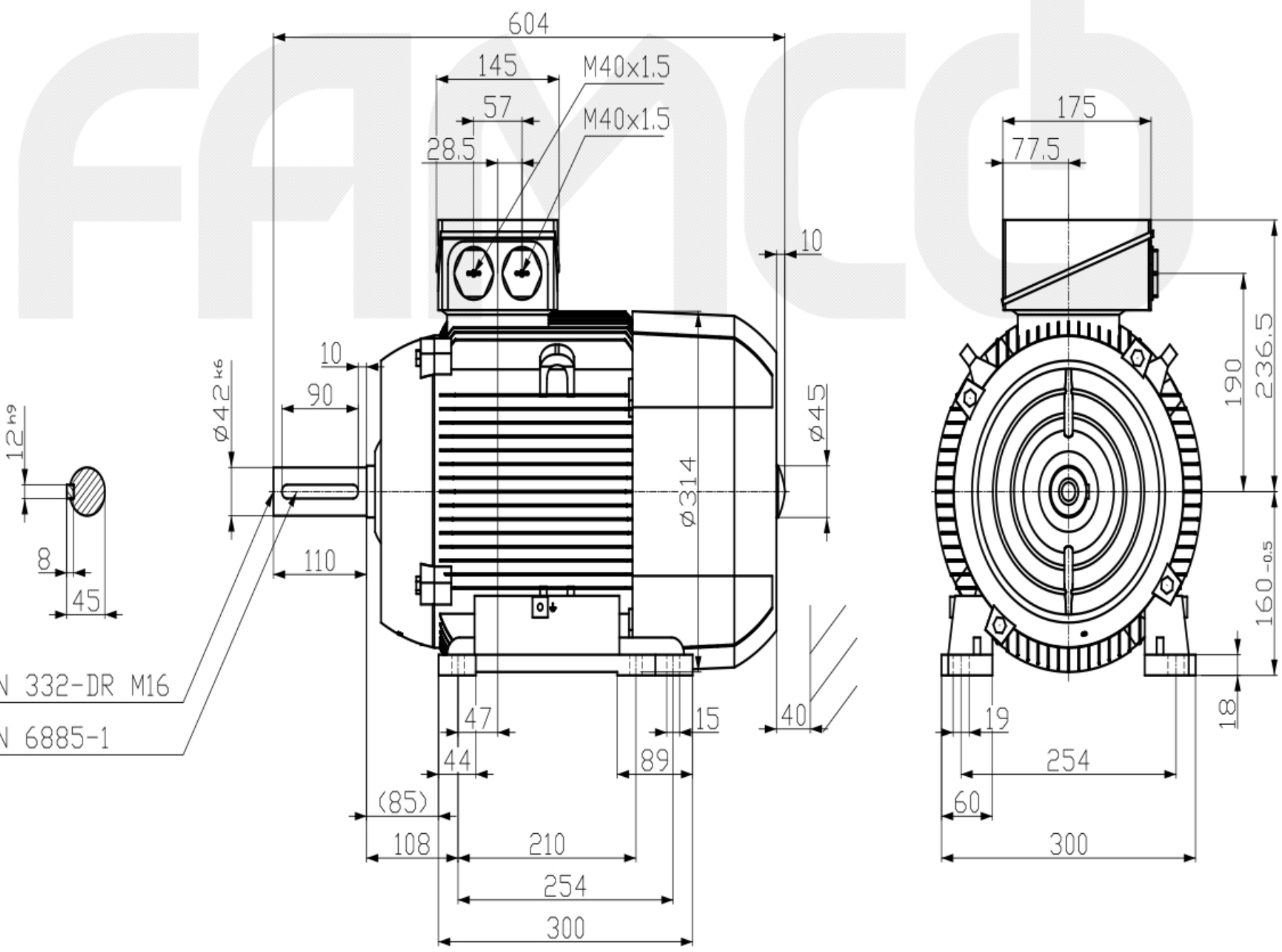

Tel: 48 0000 49 (60 Lines)

Tolerance	Surface	Material	Weight	Scale
			-	mm
1LE1002-1DC23-4AA4	Author	Dimensional drawing		
	Creator	Maßzeichnung		
	Approval	DTK		
	Department			
	Change Order	MFB	Doc. Type	
	Doc. State	1/21/19	Item No.	Page Size A3
	Revision	Index	Doc. No.	1st Language en
				2nd Language de
© Siemens AG 2018	Project No.	-	Ref. No.	Sheet 1 of 1