



MLFB-Ordering data: 1LE1502-2DB03-4AA4

Motor type: 1CV1280B

Client order no.:

Order no.:

Offer no.:

Remarks:

Item no.:

Consignment no.:

Project:

U [V]	Δ / Y	f [Hz]	P [kW]	P [hp]	I [A]	n [1/min]	M [Nm]	NOM. EFF at ... load [%]			Power factor at ... load			I _A /I _N I _f /I _N	M _A /M _N T _f /T _N	M _K /M _N T _B /T _N	IE-CL
								4/4	3/4	2/4	4/4	3/4	2/4				
400	Δ	50	75.00	- / -	137.00	1485	482.0	92.7	92.9	92.2	0.85	0.82	0.73	7.0	2.3	2.8	IE1
690	Y	50	75.00	- / -	80.00	1485	482.0	92.7	92.9	92.2	0.85	0.82	0.73	7.0	2.3	2.8	IE1
460	Δ	60	86.00	- / -	135.00	1785	460.0	93.2	93.2	92.4	0.86	0.83	0.76	7.0	2.3	2.8	IE1
IM B3 / IM 1001		FS 280 S		540 kg		IP55		IEC/EN 60034			IEC, DIN, ISO, VDE, EN						

Mechanical data

Sound pressure level 50Hz/60Hz (load)	72 dB(A) ¹⁾	76 dB(A) ¹⁾
Moment of inertia	1.20 kg m ²	
Bearing DE NDE	6317 C3	6317 C3
Relubrication interval/quantity	30 g 30 g 8000 h	
Lubricants	Esso Unirex N3	
Regreasing device	Yes (standard)	
Grease nipple	M10x1 DIN 3404 A	
Type of bearing	Locating bearing NDE	
Condensate drainage holes	Yes (standard)	
External earthing terminal	Yes (standard)	
Vibration severity grade	A	
Insulation	155(F) to 130(B)	
Duty type	S1	
Direction of rotation	bidirectional	
Frame material	cast iron	
Data of anti condensation heating	-/-	
Coating (paint finish)	Standard paint finish C2	
Color, paint shade	RAL7030	
Motor protection	(A) without (Standard)	
Method of cooling	IC411 - self ventilated, surface cooled	

Environmental conditions

Ambient temperature	-20 °C - +40 °C
Altitude above sea level	1000 m

Notes

I_A¹⁾ = locked rotor current / current nominal M_K/M_N = break down torque / nominal torque
M_A/M_N = locked rotor torque / torque nominal 1) Value is valid only for DOL operation with motor design IC411

Terminal box

Terminal box position	top
Material of terminal box	cast iron
Type of terminal box	TB1 N01
Contact screw thread	M10
Max. cross-sectional area	120.0 mm ²
Cable diameter from ... to ...	34.0 mm - 42.0 mm
Cable entry	2xM63x1,5
Cable gland	2 plugs

Special design (0)

Tel: 48 0000 49 (60 Lines)

Transmittal, reproduction, dissemination and/or editing of this document as well as utilization of its contents and communication thereof to others without express authorization are prohibited. Offenders will be held liable for any damages incurred. Patent rights, trademarks, trade names or other rights of a utility model or design patent are reserved.

Weitergabe sowie Vervielfältigung, Verbreitung und/oder Bearbeitung dieses Dokuments, Verwertung und Mitteilung seines Inhaltes sind verboten, soweit nicht ausdrücklich gestattet. Zuwiderhandlungen verpflichten zu Schadenersatz. Alle Rechte vorbehalten, insbesondere das Urheberrecht.

Confidat a titre de secret d'entreprise. Toute autre révélation, communication à quelque titre que ce soit, ou utilisation de son contenu, sans autorisation écrite de la Siemens AG, est formellement interdite.

Confidado como secreto de empresa. Nos reservamos todos los derechos.

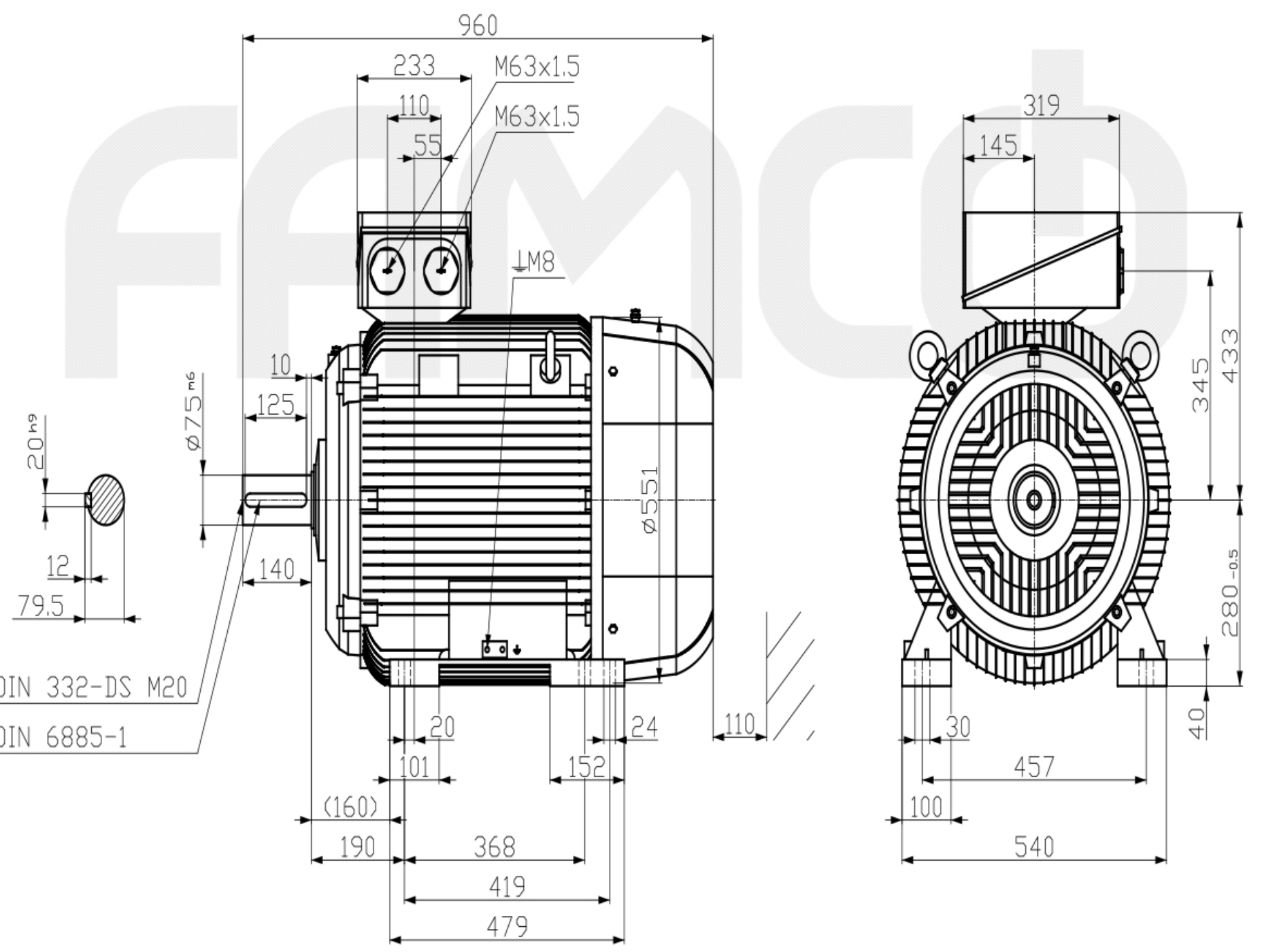

DIN 332-DS M20
 DIN 6885-1

Tel: 48 0000 49 (60 Lines)

Tolerance	Surface	Material	Weight	Scale
			-	mm
1LE1502-2DB03-4AA4	Author	Dimensional drawing Maßzeichnung		
	Creator DTK			
	Approval			
	Department			
	Change Order	MFB	Doc. Type	
	Doc. State	1/22/19	Item No	Page Size A3
	Revision	Index RS	Doc. No	1st Language en 2nd Language de
© Siemens AG 2018	Project No -		Ref No -	Sheet 1 of 1