

# MOTOVARIO

**MAINTENANCE AND USE INSTRUCTIONS OF  
MOTORVARIATORS SERIES:**

***TXF***

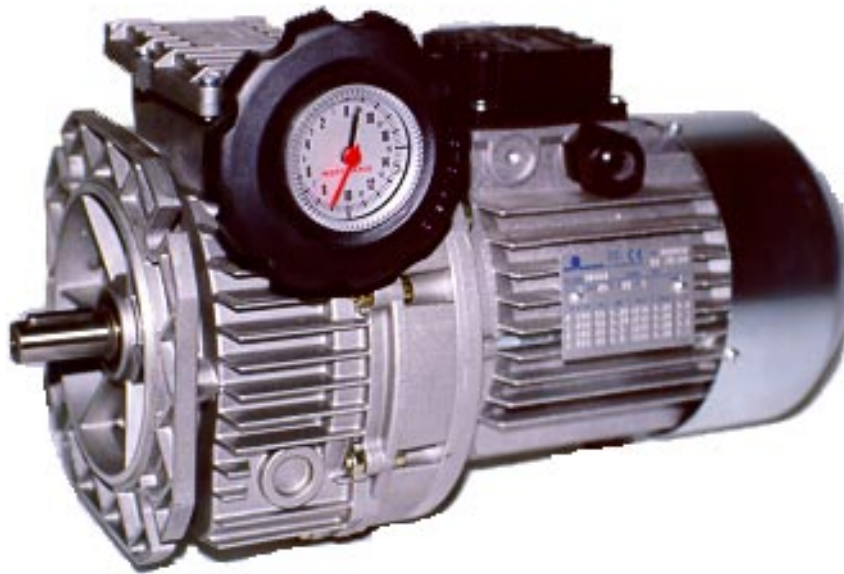

## **WAREHOUSE STORAGE**

When moving the unit, care should be taken to protect external parts from breakage or damage due to accidental knocks or falls.

If the unit is to be stored in a hostile atmosphere or for a long time (2/4 months), it is important to apply protective and waterproofing products to avoid deterioration of shafts and rubber parts.

Before starting up the unit, carry out the following checks:

Check the data shown on the name plate of the variator and/or the electric motor;

Check for any leaks of lubricant

If possible, remove any traces of dirt from the shaft and from the areas around the oil seal.

If the oil seal is not immersed in the lubricant inside the assembly during particularly long storage periods (4/6 months) it is recommended that it should be replaced as the rubber might stick to the shaft or even have lost the elasticity it needs to work properly.

## **INSTALLATION**

Particular care must be taken when installing drives, and is often the source of damage and of down time. Careful choice of the type of drive and mounting position can often avoid the need for protection of sensitive areas, particularly underneath the unit from oil leaks, however limited they may be.

The machine must be firmly fastened in place in order to prevent any vibrations

Whenever possible, protect the variator from direct sunlight and bad weather, especially when it is mounted on its vertical axis

Make sure the air intake on the fan side is unobstructed in order to ensure that the motor is correctly cooled

In the case of temperatures of  $< -10\text{ }^{\circ}\text{C}$  or  $> +50\text{ }^{\circ}\text{C}$ , contact Technical Assistance

If the motor is to be started up very often under load, the use of a heat probe inserted into the motor is recommended

The various machine members (pulleys, gear wheels, couplings, etc.) must be mounted on the shafts using special threaded holes or other systems that ensure correct operation without risk of causing damage to the bearings or the external parts of the assemblies (fig. 1)

Lubricate the surfaces that come into contact in order to prevent oxidation or seizure.

Example of a winch mounted correctly on the output shaft of a variator.  
N.B. avoid using improper tools

Fig.1

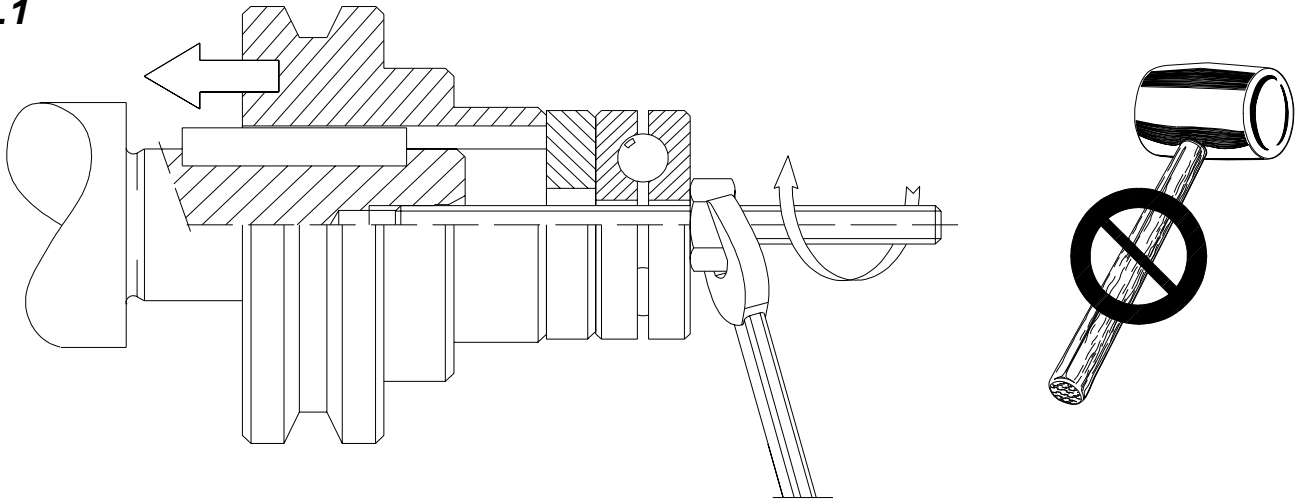

Correct (A) and incorrect (B) examples of pulleys mounted on the output shaft of a variator

Fig.2

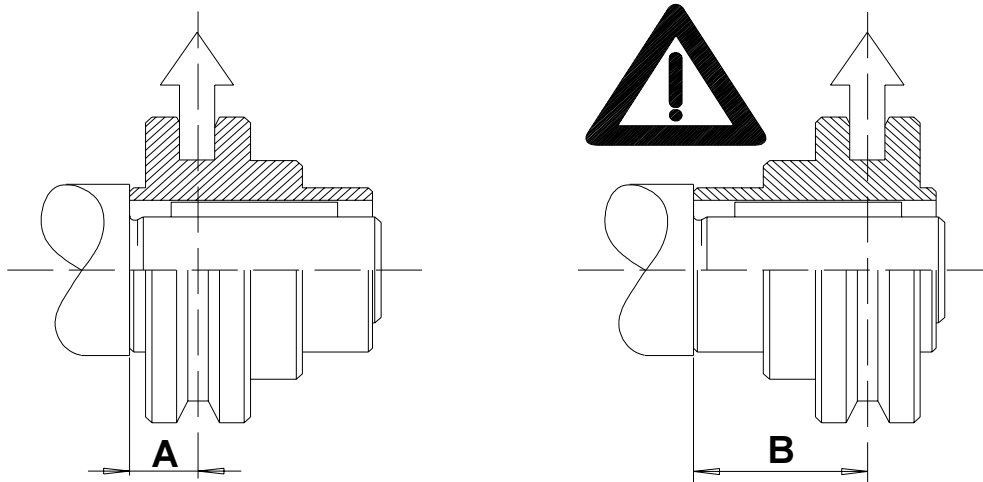

Correct (A) and incorrect (B-C) examples of coupling connections on the output shaft of a variator

Fig.3

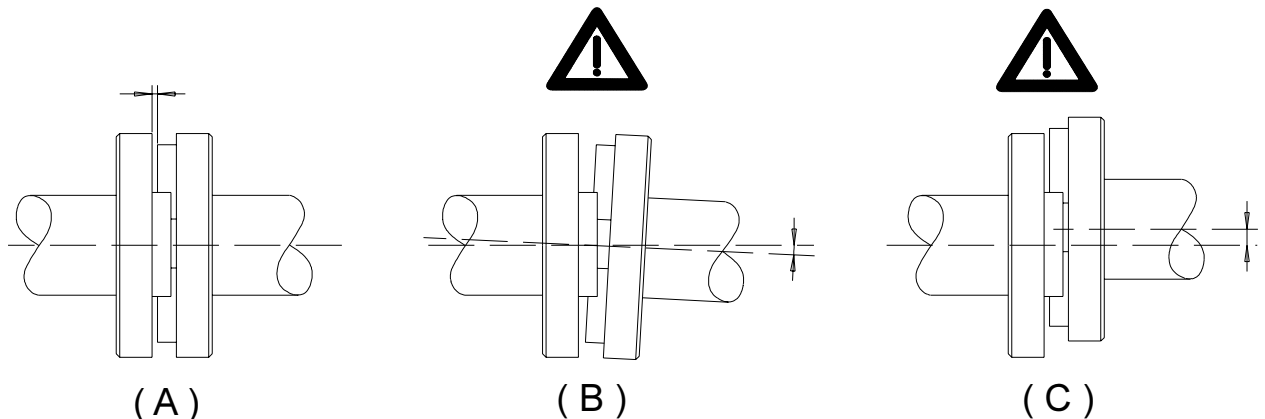

## **COUPLING NOTES**

The pulley must be mounted on the output shaft as close as possible to the stop so that it does not cause excessive radial load on the bearings (fig. 2). Great care must be taken when connecting the couplings to ensure that they are well aligned, so as not to cause excessive radial load on the bearings (fig.3). When it is applied, paint must never be used on rubber parts: oil seal, etc. It must never be applied to any breather holes in plugs if they are mounted on the unit. In the case of assemblies with oil plugs, remove the closed cap used for transport and fit it with the breather plug that is supplied with the variator. When the assembly is supplied without a motor, the following precautions must be followed in order to ensure that connections are properly made.

## **Mounting the motor on the pam B5 flange**

Check that the tolerance of the shaft and the motor flange comply with at least one 'normal' class of quality. Carefully clean off any trace of dirt or paint from the shaft, the centering and the face of the flange. Carry out mounting operations making sure not to use force. If this is not possible, check the tolerance of the motor key and ensure that it is correctly positioned. Apply assembly grease to the shaft in order to prevent oxidation or seizure caused by contact.

Good quality motors should be used in order to ensure that the unit works correctly, without vibrations or noise.

Use the oil window, if present, to check that the lubricant reaches the correct level required for the mounting position used.

## **STARTING UP**

The unit should be started up gradually: do not immediately apply the maximum load the machine is able to take ; look for and correct any malfunction that may be caused by incorrect mounting.

Running-in is essential for the variator to run properly since, notwithstanding the modern construction techniques for the gears and castings, the extreme cleanliness of the internal parts, and the excellent qualities of the lubricants used, the variator is a drive operating by friction therefore it is necessary a certain adaptation of the internal parts during the first running phases.

## **SERVICING**

The high degree of finish of the internal parts ensures that the unit will work correctly with only a minimum amount of servicing.

Generally speaking, the following rules should be followed: periodically check that the exterior of the assembly is clean, especially in the cooling areas; periodically check to see if there are any leaks, especially in the areas around the oil seals.

Assemblies that are lubricated for life and thus do not have any oil plugs do not require any special maintenance except as stated above.

For the other assemblies, low maintenance is required with an oil change at 1000 hours of use, and the following changes have to be done at 8000 hours of use. The change of oil naturally depends on the type of environment and service.

Apart from the normal maintenance rules given above, make sure the breather hole in the plug is clean and, using the oil window, periodically check that there is sufficient lubricant.

Should it be necessary to top up with lubricant, use the same type that is already in the variator or one that is compatible with it.

In case of doubtful incompatibility between lubricants, we recommend you empty out the oil from the variator completely and, before refilling with new oil, wash out the unit to remove any residue.

When changing the oil, follow the previous instructions.

## **TROUBLESHOOTING**

If any problems should arise when starting up the unit or during its first few hours of operation, contact the after sales service unit of Motovario.

The table shows a series of problems with a description of possible remedies.

It should be borne in mind however that the information given is for reference only as all the drives manufactured by Motovario are thoroughly tested and checked before they leave the factory.

Please note that tampering with the assembly without prior authorization from Motovario immediately invalidates the warranty and often makes it impossible to ascertain the causes of a defect or bad function.

PROBLEMS	CAUSES	ACTION 1	ACTION 2
The motor does not start.	Problems with power supply. Defective motor. Wrong motor size.	Check power supply.	Replace electric motor.
Current absorbed by the motor is higher than shown on the data plate.	Wrong motor size.	Check the application.	Replace the electric motor and, if necessary, the variator.
Very high temperature of the motor housing.	Defective motor. Wrong motor size.	Check the application.	Replace the electric motor and, if necessary, the variator.
Very high temperature of the variator housing.	Wrong variator size. Mounting position does not comply with the order.	Check the application.	Correct the working conditions: mounting position and/or lubricant level.
Oil leakages from oil seal.	Defective oil seal. Oil seal damaged during shipment. Defective motor shaft seat.	Replace the oil seal. Repair motor shaft seat (if possible).	Replace the part or return the unit to Motovario.
Oil leakages from joint.	Flat gasket or O-ring damaged.	Replace damaged gasket or O-ring.	Return the unit to Motovario.
The output shaft rotates in the wrong way.	Incorrect connection of the electric motor.	Reverse two phases of the power supply of the motor.	
Intermittent noise from the gears.	Dents in the internal components.	No practical problem if the noise has no effect on the application.	Return the unit to Motovario if there is significant noise in the application.
No intermittent noise from the gears.	Dirty inside the variator.	No practical problem if the noise has no effect on the application.	Return the unit to Motovario if there is significant noise in the application.
Electric motor vibrates.	Geometrical error on the coupling.	Check geometric tolerances of electric motor flange. Check tolerances and geometry of key on motor shaft.	Replace the electric motor.

**MOUNTING POSITION AND LUBRICATION**

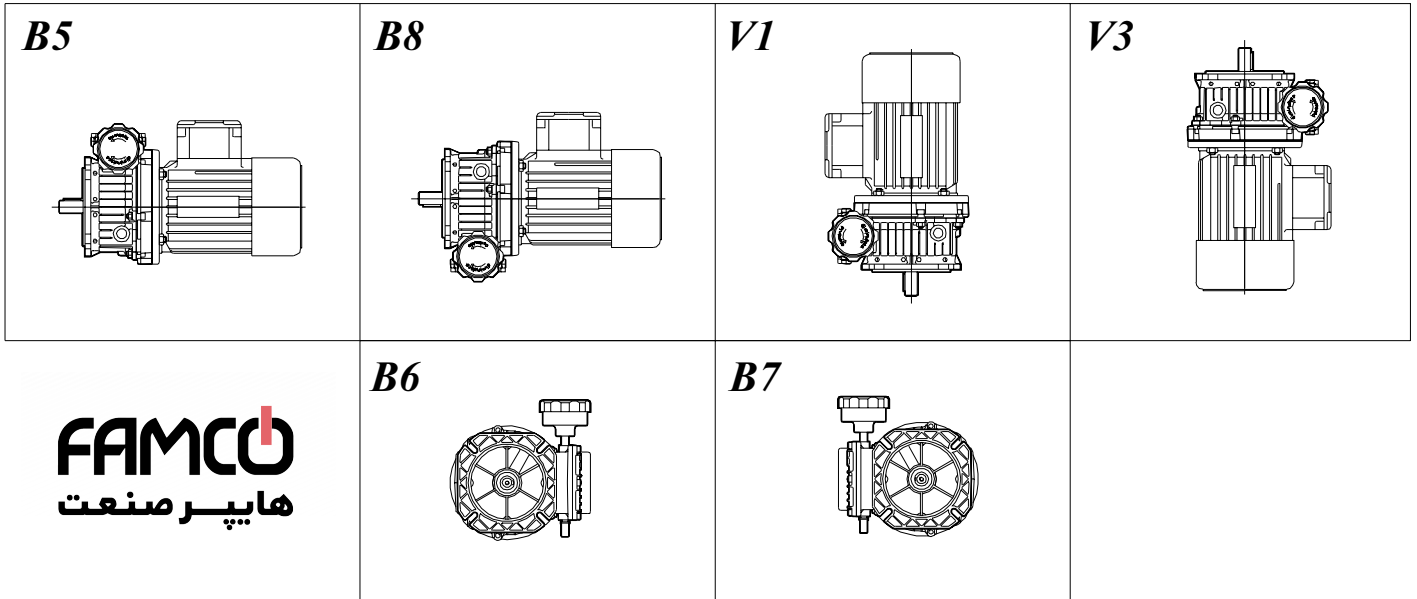

**FAMCO**  
هایپر صنعت

**Quantity of lubricant in litres**

TXF	B5 -B6 -B7	V1-V3-B8
002	0,1	0,25
005	0,13	0,4
010	0,33	0,75

TXF variators size 002-005-010 come pre-filled with lubricant for life and they do not need any maintenance. The above mentioned sizes are supplied without oil plugs.

All the variators come pre-filled with IP TRANSMISSION V.E., a mineral oil.

All the sizes, if not specified in the order, are supplied with the oil quantity as per B3-B5 mounting positions.

TXF - TXC	
Mineral	
(-25) ÷ (+ 40) ISO VG32	
IP	TRANSMISSION V.E.
SHELL	A.T.F. DEXRON
AGIP	A.T.F. DEXRON
ESSO	A.T.F. DEXRON
MOBIL	MOBIL ATF 220
CASTROL	TQ DEXRON II
BP	AUTRAN DX

## Motovariators series TX

∞

**FAMCO**  
هایپر صنعت

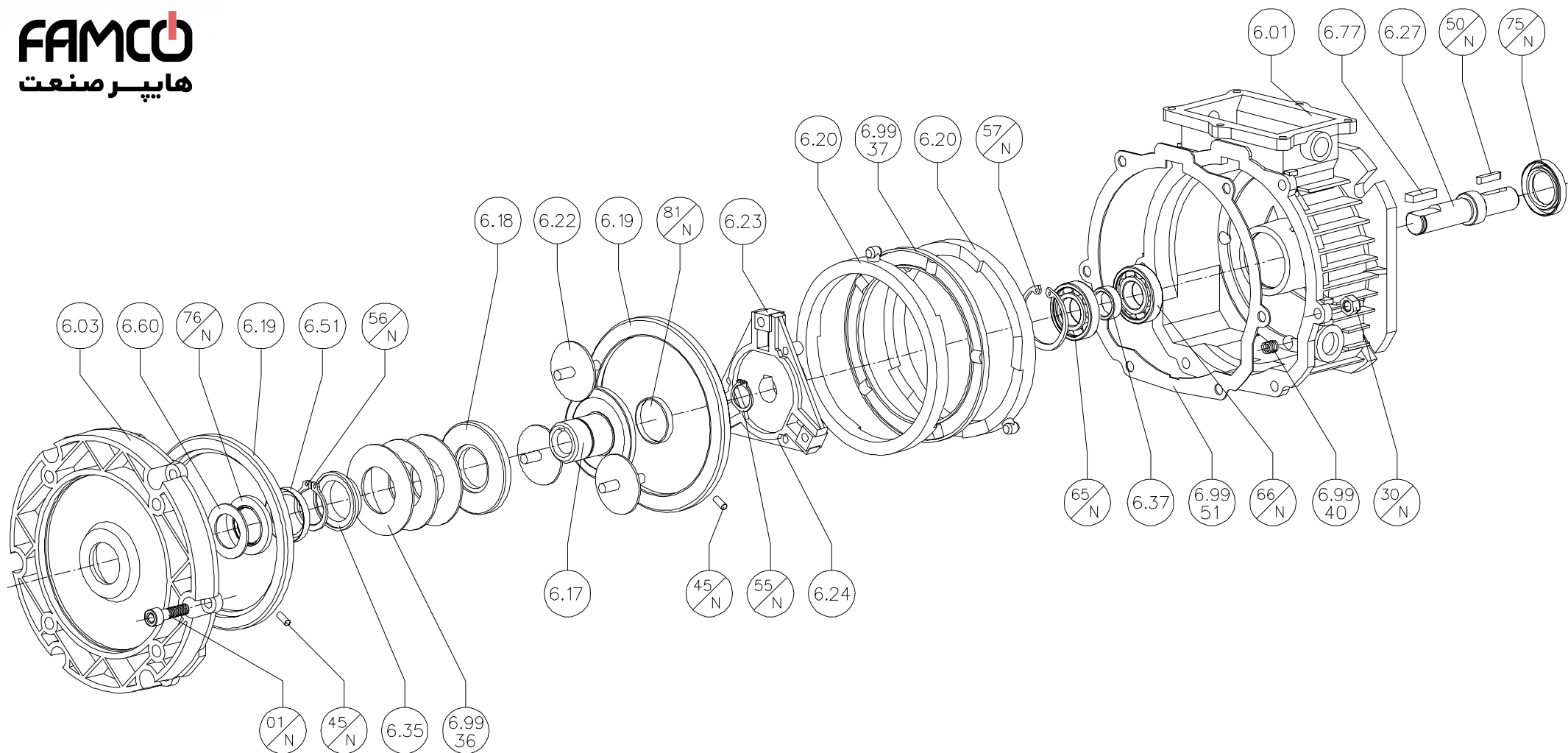

www.famcocorp.com

E-mail: info@famcocorp.com

@famco\_group

Tel: ۰۲۱-۴۸۰۰۰۰۴۹

Fax: ۰۲۱-۴۴۹۹۴۶۴۲

تهران، کیلومتر ۲۱ بزرگراه لشگری (جاده مخصوص کرج)

روبروی پالایشگاه نفت پارس، پلاک ۱۲



**TAV 001**  
**Size 002 ÷ 010**

Code	Description	002 - 063		005 - 071		005 - 080		010 - 080		010 - 090	
		Type	n°	Type	n°	Type	n°	Type	n°	Type	n°
01-N	Screw DIN 912	M6x20	6	M6x20	6	M6x20	6	M6x20	8	M6x20	8
30-N	Nut UNI 5587	M6	6	M6	6	M6	6	M6	8	M6	8
45-N	Pin UNI 6364	4x10	2	4x10	2	4x10	2	4x10	2	4x10	2
50-N	Key DIN 6885	(11) A 4x4x15	1	(14) A 5x5x20	1	(14) A 5x5x20	1	(19) A 6x6x30	1	(19) A 6x6x30	1
		(14) A 5x5x20	1	(19) A 6x6x30	1	(19) A 6x6x30	1	(24) A 8x7x35	1	(24) A 8x7x35	1
55-N	Seeger ring DIN 471	E 12	1	E 15	1	E 15	1	E 17	1	E 17	1
56-N	Seeger ring DIN 983	E18-K	1	E25-K	1	E30-K	1	E30-K	1	E45-K	1
57-N	Seeger ring DIN 472	I 28	1	I 35	1	I 35	1	I 40	1	I 40	1
65-N	Bearing	6001	1	6202	1	6202	1	6203	1	6203	1
66-N	Bearing	6001-2RS1	1	6202-2RS1	1	6202-2RS1	1	6203-2RS1	1	6203-2RS1	1
75-N	Oil seal DIN 3760	TC 15-24-7	1	TC 20-30-7	1	TC 20-30-7	1	TC 25-35-7	1	TC 25-35-7	1
76-N	Oil seal DIN 3760	SC 18-30-7	1	SC 25-40-7	1	SC 30-47-7	1	SC 30-62-7	1	SC 45-62-8	1
81-N	Cap	RCA 22-4	1	RCA 22-4	1	RCA 28-4	1	RCA 28-4	1	RCA 35-7	1

6.01	Variator casing	6.002.01	6.005.01	6.005.01	6.010.01	6.010.01
6.03	Input flange	6.002.03	6.005.03.160	6.005.03.200	6.010.03	6.010.03
6.17	Fixed sun race	6.002.17	6.005.17	6.010.17	6.010.17	1.020.17
6.18	Adjustable sun race	6.002.18	6.005.18	6.010.18	6.010.18	1.020.18
6.19	Annulus race	6.002.19	6.005.19	6.005.19	6.010.19	6.010.19
6.20	Cam ring	6.002.20	6.005.20	6.005.20	6.010.20	6.010.20
6.22	Planet disk	(3) 6.002.22	(3) 6.005.22	(3) 6.005.22	(3) 6.010.22	(3) 6.010.22
6.23	Friction bearing - planet disk	(3) 6.002.23	(3) 6.002.23	(3) 6.002.23	(3) 6.010.23	(3) 6.010.23
6.24	Planet carrier	6.002.24	6.005.24	6.005.24	6.010.24	6.010.24
6.27	Output shaft	6.002.27	6.005.27	6.005.27	6.010.27	6.010.27
6.35	Stop ring belleville springs	6.002.35	6.005.35	6.010.35	6.010.35	6.010.35.090
6.37	Bearings spacer	6.002.37	6.005.37	6.005.37	6.010.37	6.010.37
6.51	Centrifugal oil seal	6.002.51	6.005.51.071	6.005.51.080	6.005.51.080	6.010.51.090
6.60	Guide ring				6.010.60	
6.77	Special key				6.010.77	6.010.77
6.99.36	Belleville spring assembly	(3) 1.002.99.36	(3) 1.005.99.36	(5) 1.010.99.36	(5) 1.010.99.36	(3) 1.020.99.36
6.99.37	Ball ring	6.002.99.37	6.005.99.37	6.005.99.37	6.010.99.37	6.010.99.37
6.99.40	Coil spring	(3) 1.002.99.40	(4) 1.002.99.40	(4) 1.002.99.40	(4) 6.010.99.40	(4) 6.010.99.40
6.99.51	Flange gasket	6.002.99.51	6.005.99.51	6.005.99.51	6.010.99.51	6.010.99.51

## Motovariators series TX

**FAMCO**  
هایپر صنعت

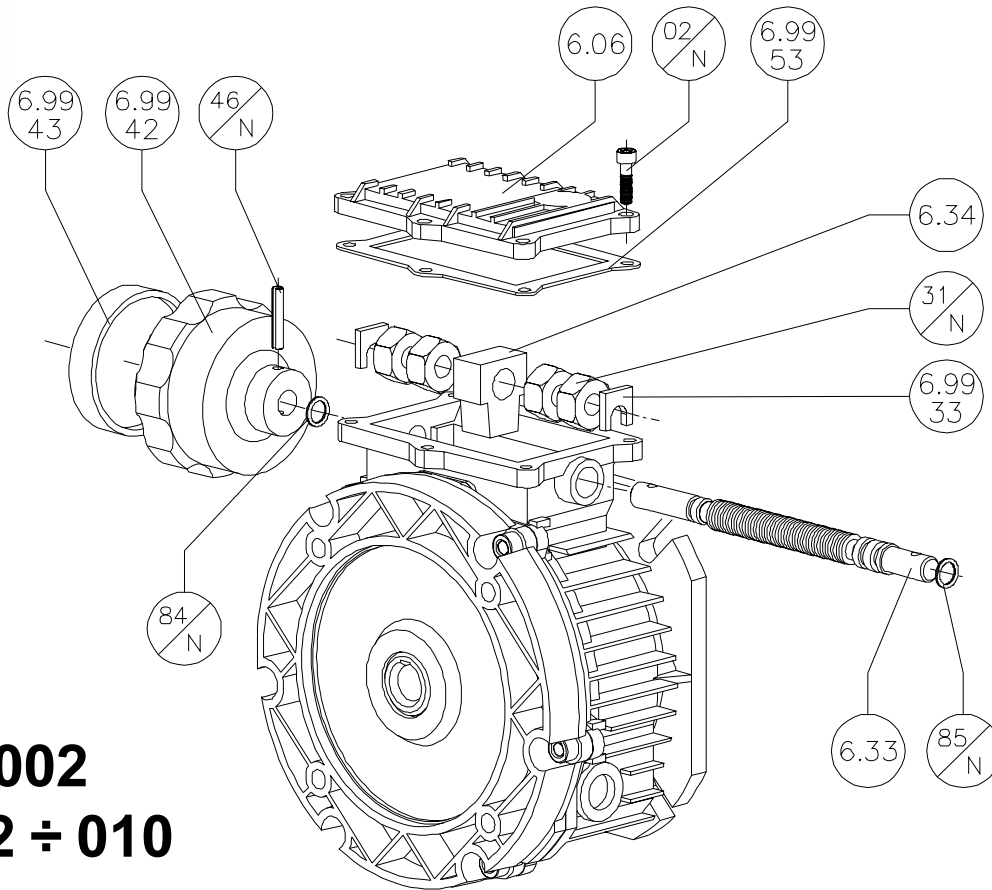

**TAV 002**  
**Size 002 ÷ 010**

Code	Description	002 - 063		005 - 071		005 - 080		010 - 080		010 - 090	
		Type	n°	Type	n°	Type	n°	Type	n°	Type	n°
02-N	Screw SFS torx TN912/8.8	M5x14	6	M5x14	6	M5x14	6	M5x14	6	M5x14	6
31-N	Nut UNI 5589	M12x1.5	4	M12x1.5	4	M12x1.5	4	M14x2	4	M14x2	4
46-N	Pin UNI 6873	4x24	1	4x24	1	4x24	1	4x24	1	4x24	1
84-N	O-Ring	OR 106	1	OR 106	1	OR 106	1	OR 108	1	OR 108	1
85-N	O-Ring	OR 108	1	OR 108	1	OR 108	1	OR 2043	1	OR 2043	1

6.06	Cover-control screw	6.002.06	6.002.06	6.002.06	6.010.06	6.010.06
6.33	Control screw	6.002.33	6.002.33	6.002.33	6.010.33	6.010.33
6.34	Control block	6.002.34	6.002.34	6.002.34	6.010.34	6.010.34
6.99.33	Stop plate	(2) 6.002.99.33	(2) 6.002.99.33	(2) 6.002.99.33	(2) 6.010.99.33	(2) 6.010.99.33
6.99.42	Handwheel	6.002.99.42	6.002.99.42	6.002.99.42	6.010.99.42	6.010.99.42
6.99.43	Handwheel cover	6.002.99.43	6.002.99.43	6.002.99.43	6.002.99.43	6.002.99.43
6.99.53	Cover gasket	6.002.99.53	6.002.99.53	6.002.99.53	6.010.99.53	6.010.99.53