

FAMCO
هایپر صنعت

MQ

Self-priming multistage pumps
50 Hz



General data

Applications	3
Type key	3
Pumped liquids	3
Operating conditions	3
Technical data	3
Features and benefits	3
Control panel	4
Installation	4
Product range, 1 x 220-240 V	4

Technical data

Material specification	5
Performance curves	6
Dimensions	6
Technical data	6

Applications

The MQ pump is designed for water supply and pressure boosting

- in private homes
- in summer houses and weekend cottages
- on farms
- in market gardens and other large gardens.

The pump is suitable for pumping of potable water and rainwater.

Type key

Example	MQ	3	-35	A	-O	-A	- BVBP
Pump range							
Rated flow [m ³ /h]							
Maximum head [m]							
Code for pump version							
A: Standard							
Code for pipework connection							
O: External thread							
Code for materials							
A: Standard							
Code for shaft seal							

Pumped liquids

Potable water, rainwater or other clean, thin, non-aggressive liquids, not containing solid particles or fibres.

Operating conditions

System pressure:	Max. 7.5 bar
Inlet pressure:	Max. 3 bar
Suction lift:	Max. 8 m
Liquid temperature:	0 °C to +35 °C
Ambient temperature:	0 °C to +45 °C.

Technical data

Mains voltage:	1 x 220-240 V, 50 Hz
Voltage tolerances:	- 10 % / + 6 %
Enclosure class:	IP 54
Insulation class:	B
Sound pressure level:	≤55 dB(A)
Marking:	CE.

Features and benefits

- **Complete system**
The MQ is a complete, all-in-one unit, incorporating pump, motor, diaphragm tank, pressure and flow sensor, controller and non-return valve. The controller ensures that the pump starts automatically when water is consumed and stops automatically when the consumption ceases. In addition, the controller protects the pump in case of faults.
- **Installation**
Due to its compact design, the pump does not take up much space and is easy to install. No space around the pump is required.
- **Simple operation**
The pump features a user-friendly control panel with On/Off button and indicator lights for indication of the operational state of the pump.
- **Self-priming pump**
As it is self-priming, the MQ is able to pump water from a level below the pump. Provided it is filled with water, the pump is able to lift water from a depth of 8 m in less than 5 minutes. This facilitates installation and start-up of the pump and provides more reliable water supply in installations where there is a risk of dry running and leakages in suction hose or pipes.
- **Built-in protective functions**
If exposed to dry running or excessive temperature, for example in case of seizure or overload, the pump will stop automatically, thus preventing a motor burnout.
- **Automatic reset**
The pump features an automatic reset function. In case of dry running or similar alarm, the pump will stop. Restarting will be attempted every 30 minutes for a period of 24 hours. The reset function can be deactivated.
- **Low noise level**
Thanks to its hydraulic design and internal cooling, the pump is extremely low-noise, which makes it suitable for both indoor and outdoor use.
- **Pressure tank**
The built-in pressure tank reduces the number of starts and stops in case of leakages in the pipe system, causing less wear on the pump.
- **Maintenance**
No maintenance of the pump is required.

Control panel

Operation of the MQ pump is effected entirely via the control panel.

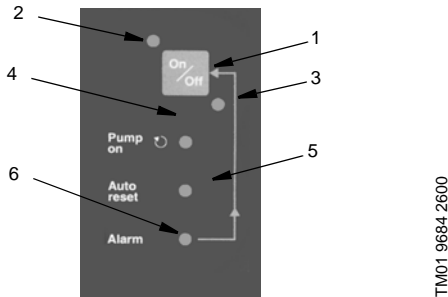

TM01 9684 2600

Fig. 1 MQ control panel

Pos.	Function	Description
1	On/Off button	The pump is started and stopped with the On/Off button.
2	Indicator light for mains connection (green)	Indicates that the pump is ready for operation.
3	Indicator light for mains connection (red)	Indicates that the pump is on standby.
4	Pump on (green)	Indicates that the pump is running.
5	Auto reset (green)	Indicates that the auto reset function is active. After an alarm, restarting will be attempted every 30 minutes for a period of 24 hours.
6	Alarm (red)	Indicates that the pump is in alarm state. Manual resetting is possible by pressing the On/Off button.

Product range, 1 x 220-240 V

Region	Pump type	Plug type					Product number
		Schuko	Swiss	Danish	Australian	Without plug	
All 50 Hz markets, except for UK, Ireland, Australia	MQ 3-25	●					96515520
	MQ 3-35	●					96515412
	MQ 3-35		●				96515413
	MQ 3-35			●			96515414
	MQ 3-45	●					96515415
	MQ 3-45		●				96515416
	MQ 3-45			●			96515417
UK, Ireland	MQ 3-35					●	96515418
	MQ 3-45					●	96515419
Australia	MQ 3-35				●		96515510
	MQ 3-45				●		96515511

All pumps are supplied with a 2 m cable.

Installation

Self-cooling, compact and horizontal, the pump is well suited for installations where space is limited.

In addition, the pump discharge is flexible, $\pm 5^\circ$, to facilitate connection to existing pipework.

The pump is supplied complete with a 2 m cable.

Material specification

Pos.	Component	Material
2	Motor stool with base plate	POM + 25 % glass fibre
4	Chamber	PPO + 20 % glass fibre
7	Drain and priming plug	POM + 25 % glass fibre
10	Self-priming valve	PP + 30 % glass fibre
14	Self-priming part	PPE/PS + 20 % glass fibre
16	Pump sleeve	Stainless steel, DIN W.-Nr. 1.4301, AISI 304
42	Pressure tank	Butyl (diaphragm)
49	Impeller	PPO + 20 % glass fibre and PTFE
65	Non-return valve	POM + 25 % glass fibre
92	Clamp	Stainless steel, DIN W.-Nr. 1.4301, AISI 304
100a	Discharge port	POM + 25 % glass fibre
101	Suction port	POM + 25 % glass fibre
103	Shaft seal:	Carbon/ceramics/NBR rubber
104	Stationary and rotating parts	
150	Shaft	Stainless steel, DIN W.-Nr. 1.4005, AISI 416
	Motor sleeve	Stainless steel, DIN W.-Nr. 1.4301, AISI 304
174a	Pressure switch	
184	Flow sensor	
	O-rings	NBR rubber

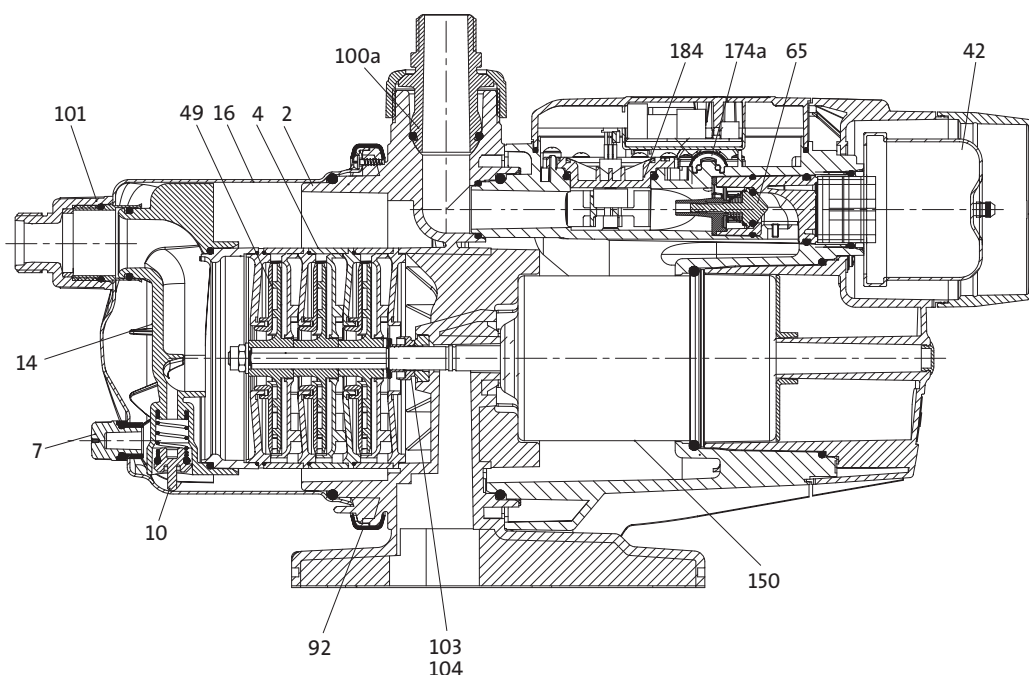
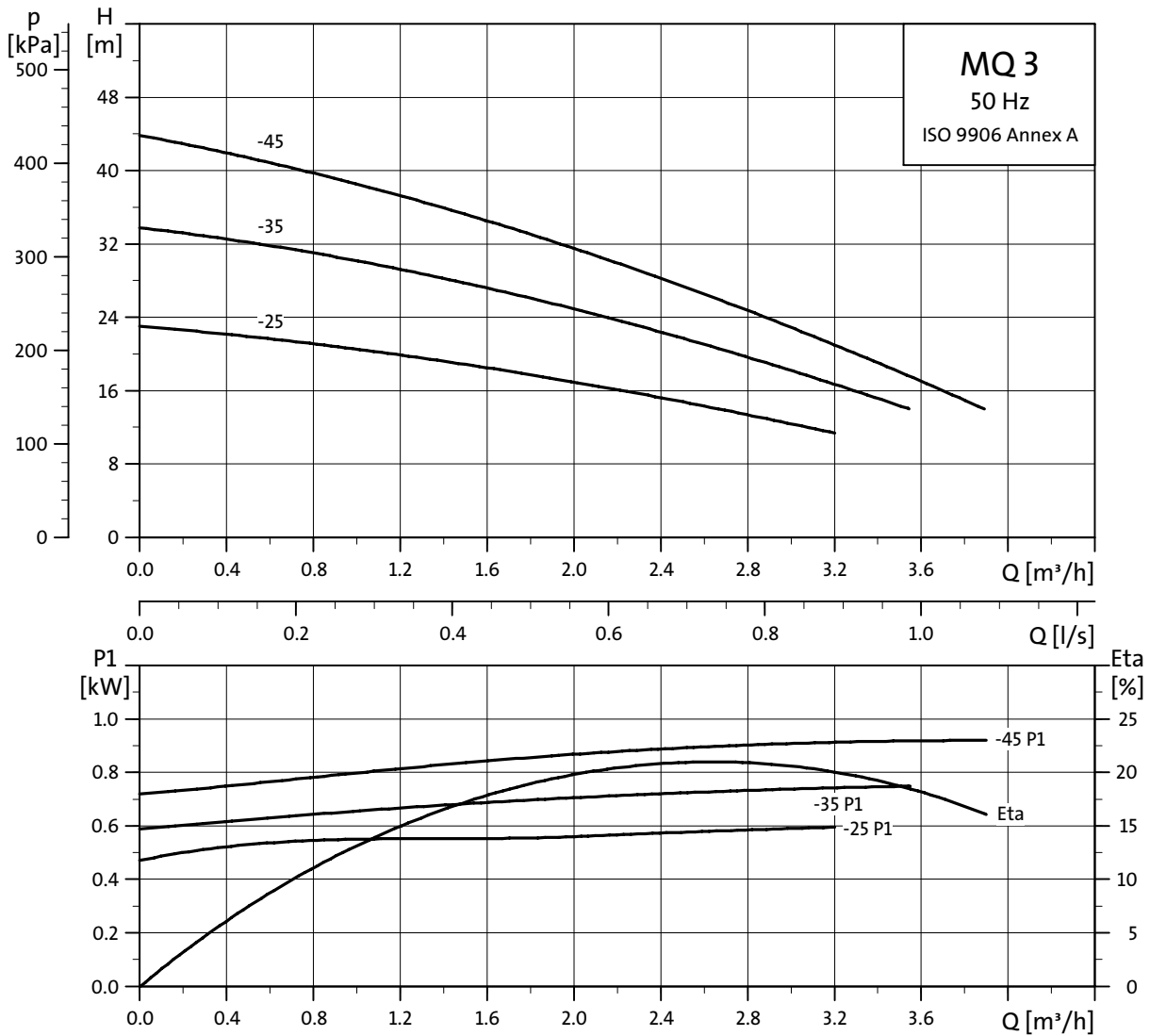

Fig. 2 Sectional drawing of MQ

TM01 9733 5006

Performance curves



TM01 9678 4103

Dimensions

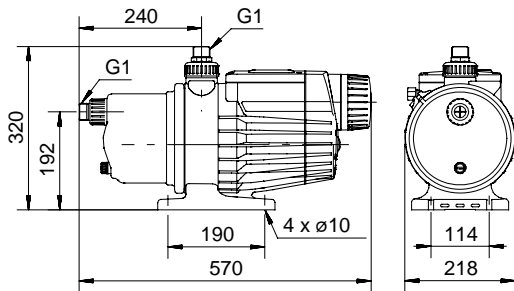

TM01 9734 2800

Technical data

Pump type	Voltage	$I_{1/1}$ [A]	I_{start} [A]	P_2 [W]	Net weight [kg]
MQ 3-25	1 x 220-240 V	3.3	11.7	450	13.0
MQ 3-35	1 x 220-240 V	4.0	11.7	550	13.0
MQ 3-45	1 x 220-240 V	4.5	11.7	670	13.0



V7164094 0607	GB
Repl. V7164094 1106	

Subject to alterations.