

FAMCO

هایپر صنعت

- www.famco.co.ir
- www.famcocorp.com



PUMPS
پمپ

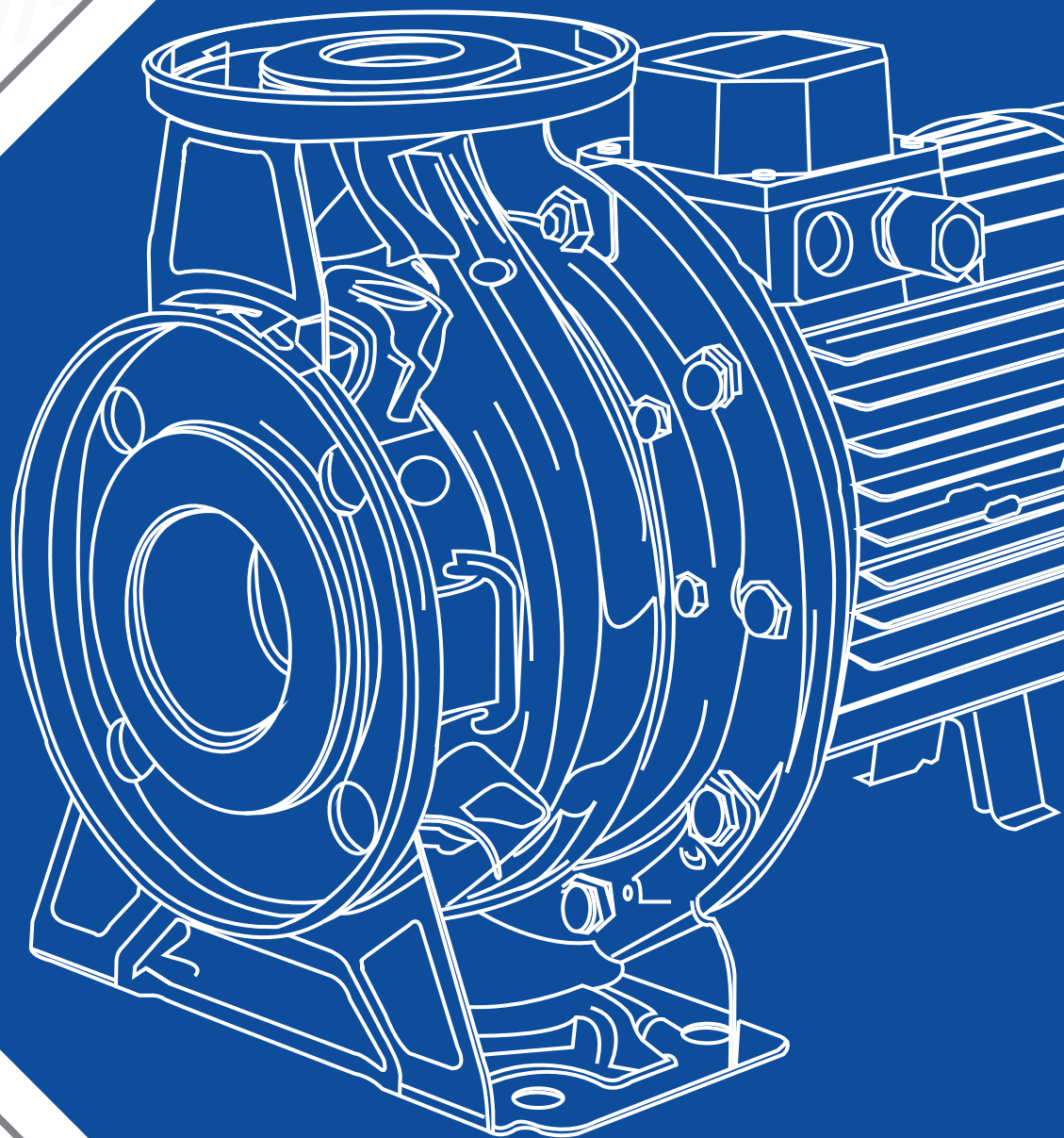

Catalog 2018 • • Symbol of the dynamism in industry

DML Series

SUBMERSIBLE PUMPS for dirty water



الکتروپمپ های مستغرق برای فاضلاب و آبهای آلوده سری (DML) 

مناسب برای سیستم های فاضلاب و آبهای آلوده

موتور	
1450	دور موتور (rpm)
F	کلاس عایقندی
IP 68	درجه محافظت
50	فرکانس (Hz)
مستقیم (2.2kw)	روش راه اندازی
ستاره - مثلث (3.7kw تا 22kw)	
3.7-22kw 2.2kw	محافظ حرارتی محافظ اضافه بار
10	طول کابل برق (m)

پمپ		
فاصلاب	نوع مایع	مشخصات سیال
40	حداکثر دما (°C)	
76	حداکثر قطر ذرات معلق (mm)	عمق غوطه وری
8	حداکثر (m)	
2/3 ارتفاع پمپ	حداقل (m)	ساختار
پروانه باز تک کاناله	پروانه	
دارای دو مکانیکال سیل در محفظه روغن	نوع آب بندی	
بلبرینگ با گریس دائمی	یاتاقان	
80-100-150	دهانه رانش (mm)	
چدن	پوسته	
چدن	پروانه	
استنلس استیل 403	شفت	جنس
1. سمت پروانه Silicon/NBR 2. سمت موتور Carbon/Ceramic/NBR 3. مایع روغنکاری: روغن توربین VG32 (SAE 10W/20W)	سیل مکانیکی	
جعبه حاوی اتصالات زانویی، فلنج، پیچ و مهره و واشر		متعلقات

DML Series

SUBMERSIBLE PUMPS for dirty water

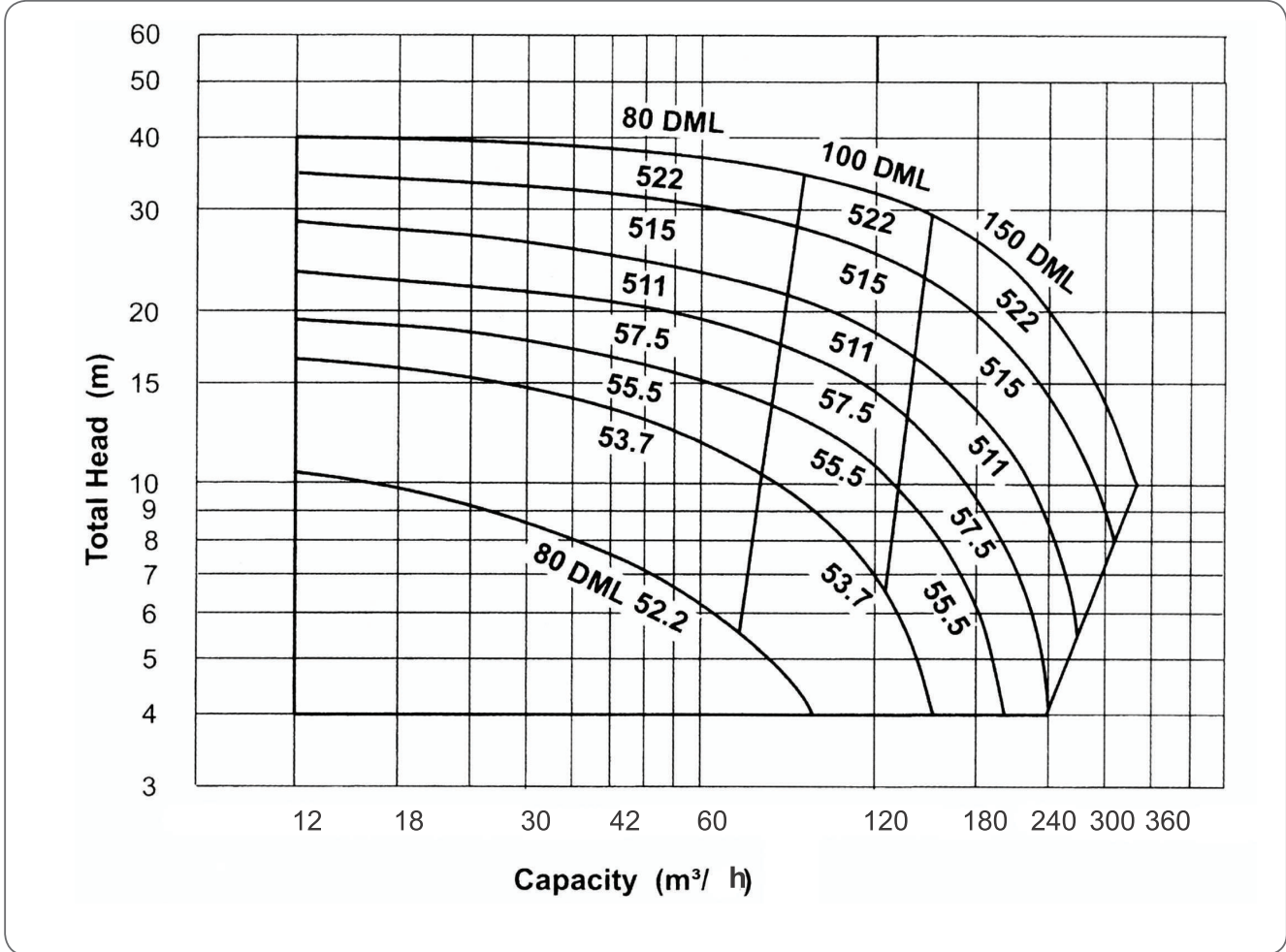

DML Series

SUBMERSIBLE PUMPS for dirty water

Discharge Flange Dimensions (JIS 10kgf/cm)

DA	DE	DF	DG	DT	DN	DD
80	150	185	126	18	8	15
100	175	210	151	20	8	15
150	240	280	212	22	8	19

Note:
1/. L.W.L (Low Water Level) is limited to 10 minutes operation at low water level.
2/. Is limited to 30 minutes operation with water level below top of motor.

Size	Model	Output KW	A	B	c	D	E	F	H	J	L1	CL	Weight
80	80DML52.2	2.2	534	320	378	157	285	298	668	210	279	10m	80 kg
	80DML53.7	3.7	534	320	378	157	285	298	727	210	279	10m	87 kg
	80DML55.5	5.5	640	381	453	188	360	334	824	255	310	10m	118kg
	80 DML 57.5	7.5	640	381	453	188	360	334	824	255	310	10m	123 kg
	80DML511	11	734	455	513	221	420	350	938	315	329	10m	157 kg
	80DML515	15	734	455	513	221	420	350	938	315	329	10 m	163 kg
100	80 DML 522	22	777	497	533	245	440	363	1021	335	332	10m	223 kg
	100 DML 52.2	2.2	577	320	420	157	315	313	668	210	279	10 m	81 kg
	100 DML 53.7	3.7	577	320	420	157	315	313	727	210	279	10m	89 kg
	100DML55.5	5.5	653	381	465	188	360	334	824	255	310	10 m	121 kg
	100DML57.5	7.5	653	381	465	188	360	334	824	255	310	10m	125kg
	100DML511	11	746	455	525	221	420	350	938	315	329	10m	160 kg
150	100DML515	15	746	455	525	221	420	350	938	315	329	10m	166kg
	100DML522	22	790	497	545	245	440	363	1021	335	332	10m	226 kg
	150 DML 55.5	5.5	713	381	525	188	385	369	824	255	310	10m	127kg
	150 DML 57.5	7.5	713	381	525	188	385	369	824	255	310	10m	132kg
	150DML511	11	806	455	585	221	445	385	938	315	329	10m	166kg
	150DML515	15	806	455	585	221	446	385	938	315	329	10m	172kg
	150DML522	22	850	497	605	245	465	398	1021	335	332	10m	232 kg

DML Series SUBMERSIBLE PUMPS for dirty water

80 DML

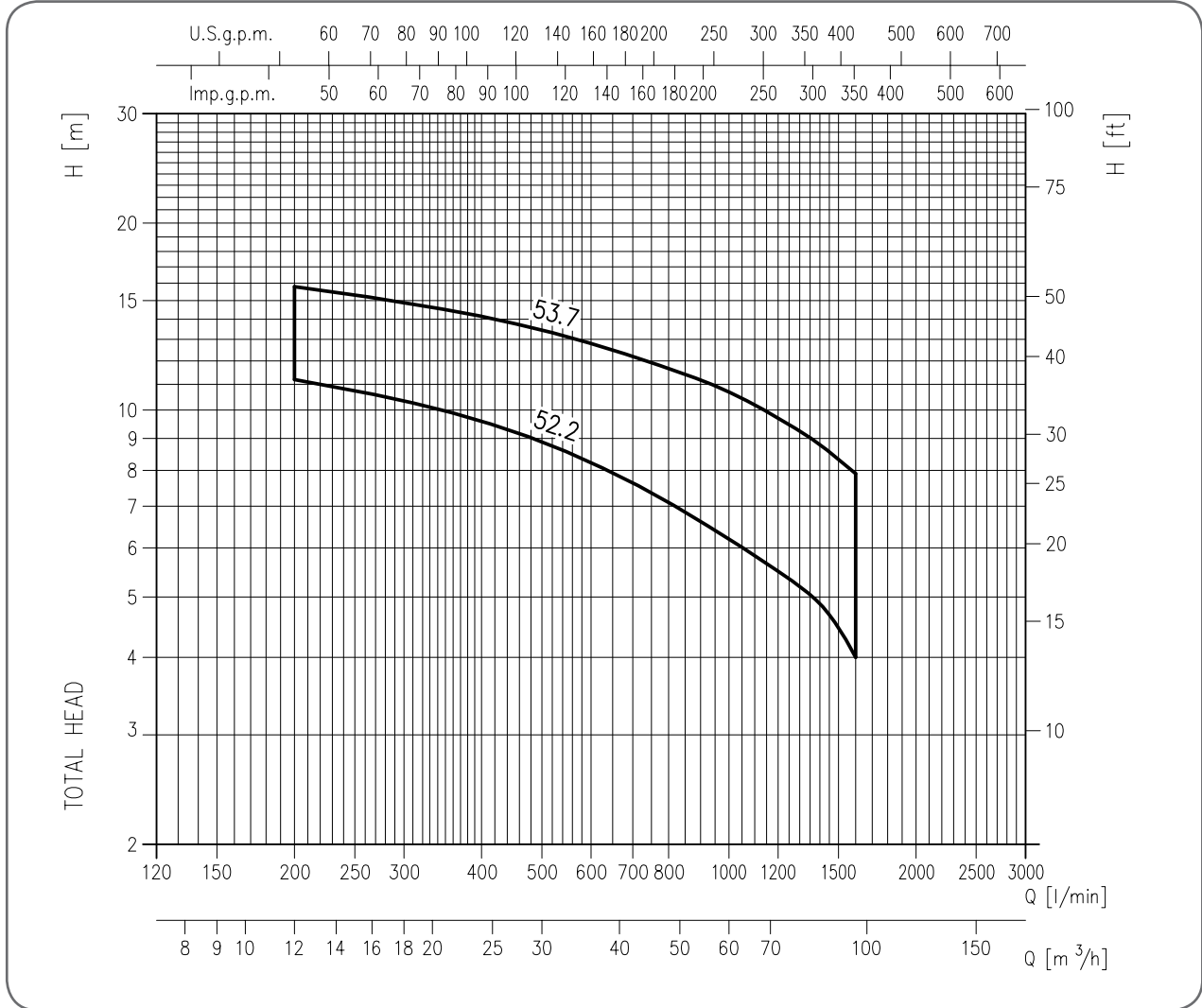

PERFORMANCE TABLE

جدول فنی:

PUMPTYPE DML	kW	HP	Q= Capacity									
			[l/min]	0	500	1000	1300	1600	1900	2200	2400	2500
			[m ³ /h]	0	30	60	78	96	114	132	144	150
H=total manometric head [m]												
80DML52.2	2.2	3	-	13.1	11.2	9.6	8.2	7.1	6.2	5.5	4.9	4
80DML53.7	3.7	5	-	17.9	15.8	14.2	12.8	11.7	10.7	9.7	8.8	7.9
80DML55.5	5.5	7.5	-	17.9	19.8	18.4	17	15.9	14.8	13.6	12.8	11.9
80DML57.5	7.5	10	-	24.9	23.2	21.6	20.4	19.2	18	16.9	15.9	15.2
80DML511	11	15	-	30.2	29.5	28.4	27.4	26.4	25.5	24.6	23.6	22.4
80DML515	15	20	-	35.6	35	34.4	33.8	32.9	32	30.4	28.8	28
80DML522	22	30	-	40	39.5	39.2	38.4	37.9	37.2	36.7	35.9	34.6

DML Series SUBMERSIBLE PUMPS for dirty water

100 DML

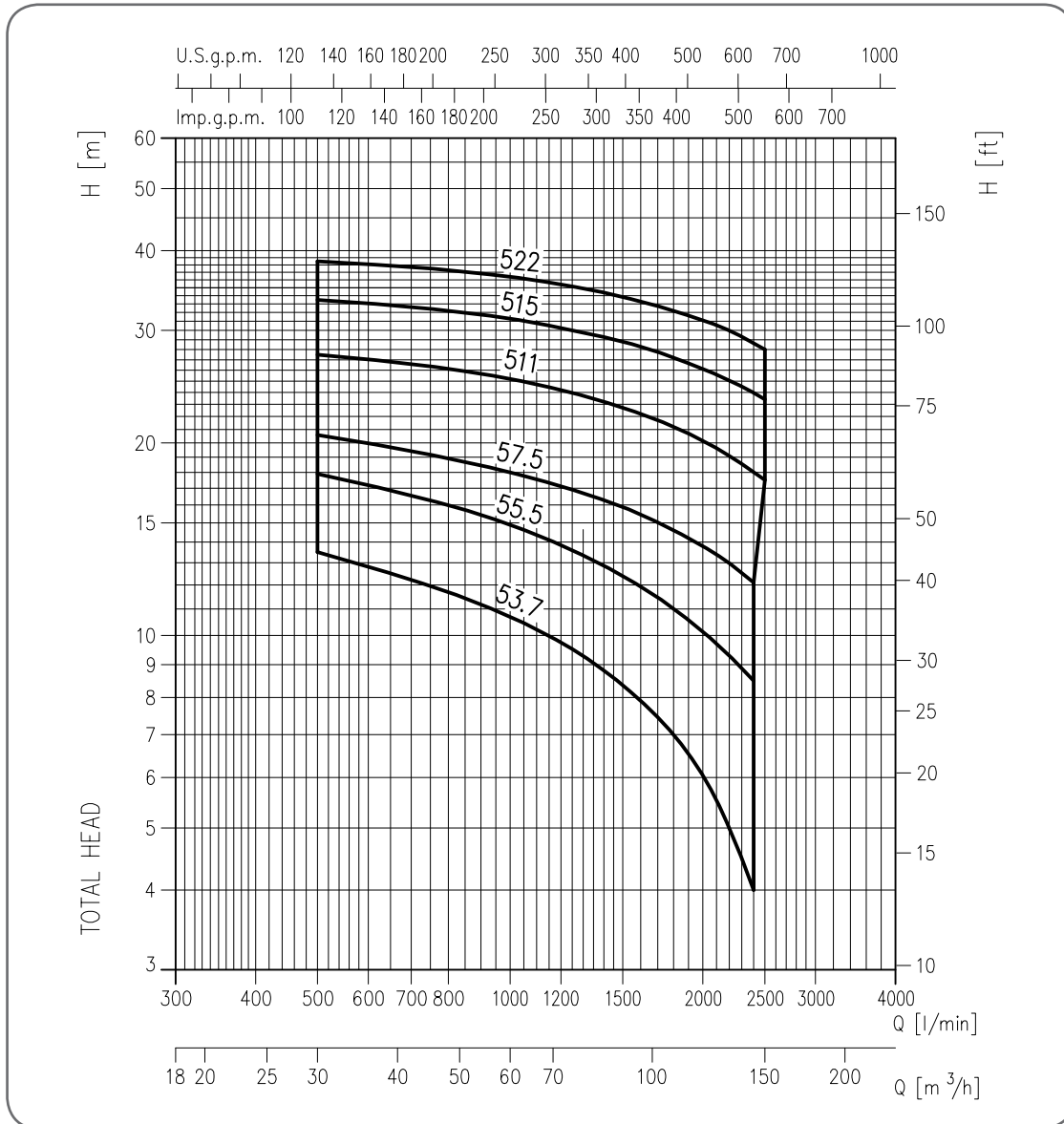

PUMPTYPE DML	kW	HP	Q= Capacity									
			[l/min]	0	500	1000	1300	1600	1900	2200	2400	2500
			[m³/h]	0	30	60	78	96	114	132	144	150
H=total manometric head [m]												
100DML53.7	3.7	5	-	17.9	13.5	10.7	9.3	7.9	6.5	5	4	-
100DML55.5	5.5	7.5	-	22	17.9	14.9	13.4	11.9	10.6	9.3	8.5	-
100DML57.5	7.5	10	-	25.3	20.6	18	16.7	15.5	14.2	13	12.1	-
100DML511	11	15	-	30.3	27.5	25.2	23.7	22.2	20.7	19.1	18	17.5
100DML515	15	20	-	35	33.5	31.3	29.8	28.3	26.7	25.1	24	23.4
100DML522	22	30	-	40	38.5	36.4	34.9	33.3	31.7	30	28.7	28

DML Series SUBMERSIBLE ELECTRO PUMPS

150 DML

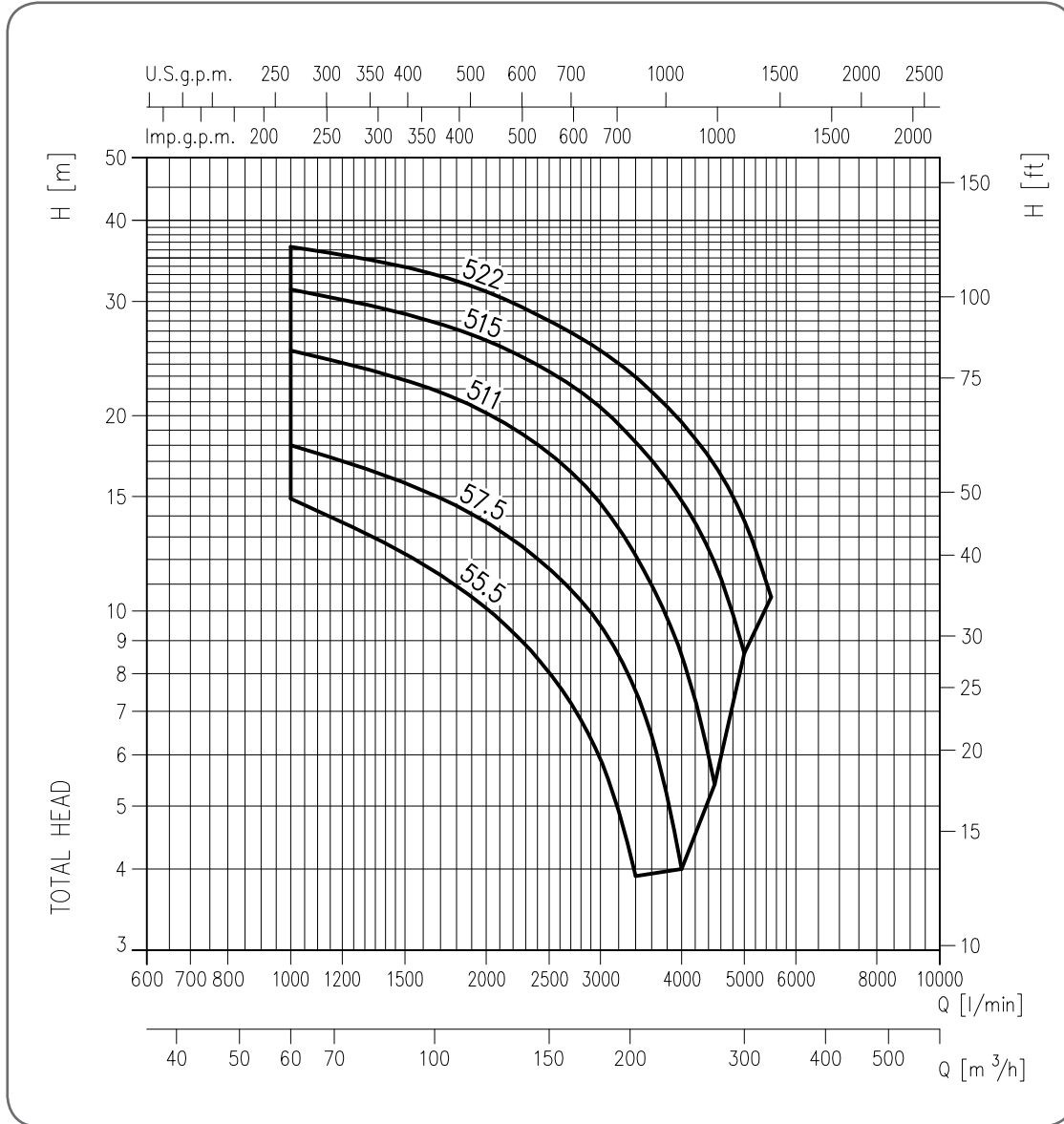

PUMP TYPE	kW	HP	Q= Capacity										
			[l/min]	0	1000	2000	2500	3000	3400	4000	4500	5000	5500
			[m3/h]	0	60	120	150	180	204	240	270	300	330
H=total manometric head [m]													
150DML55.5	5.5	7.5	-	22	14.9	10.1	8	5.9	3.9	-	-	-	-
150DML57.5	7.5	10	-	25.3	18	13.7	11.6	9.5	7.5	4	-	-	-
150DML511	11	15	-	30.3	25.2	20.2	17.5	14.7	12.2	8.6	5.4	-	-
150DML515	15	20	-	35	31.3	26.1	23.4	20.6	18.2	14.8	11.9	8.6	-
150DML522	22	30	-	40	36.4	31.1	28	25.2	22.9	19.5	16.8	13.8	10.5

DML Series SUBMERSIBLE ELECTRO PUMPS

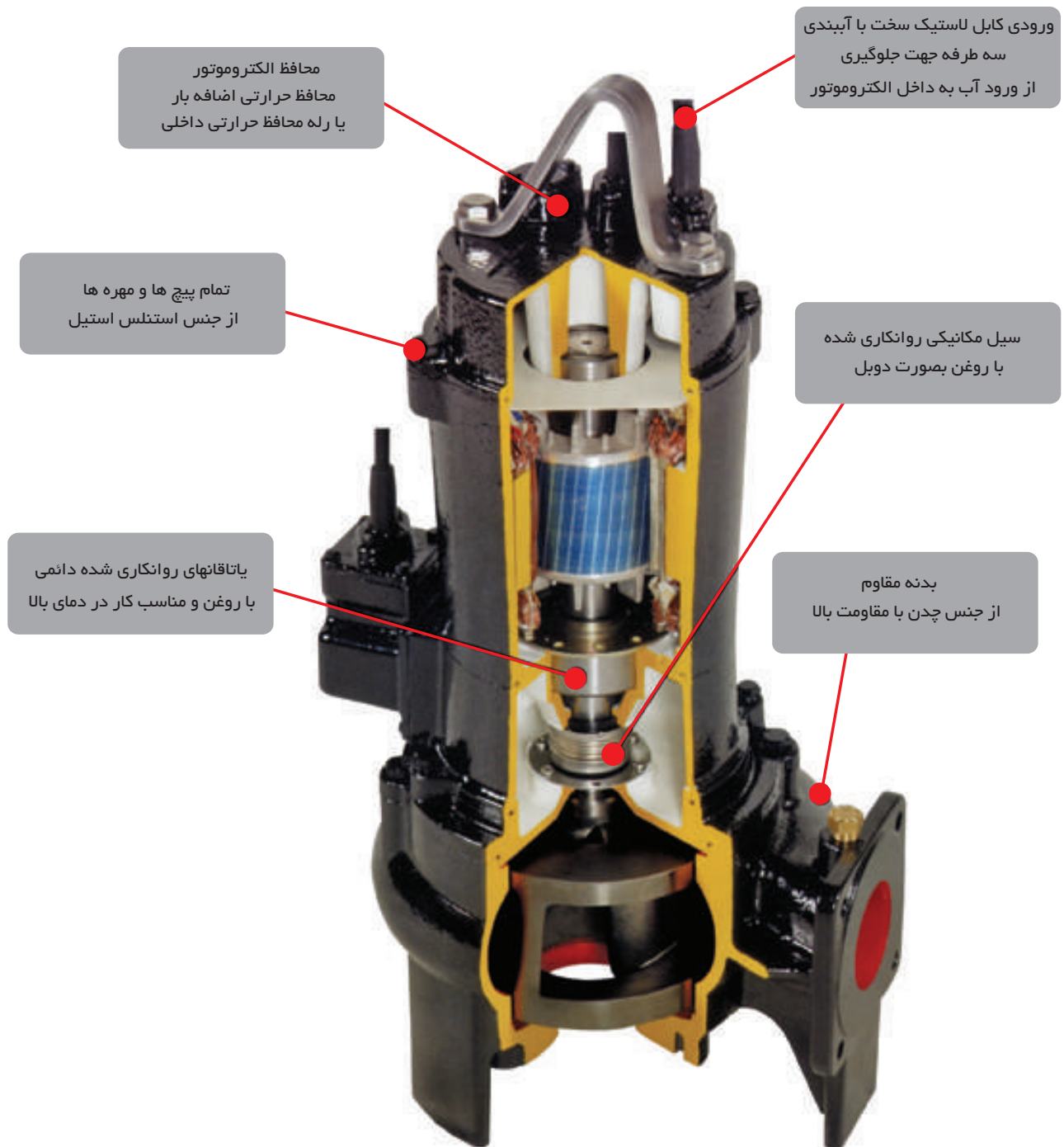

DL Series SUBMERSIBLE SEWAGE PUMPS



الکتروپمپ های لجن کش چدنی به همراه خرد کن سری (DL)



مناسب جهت فاضلاب های صنعتی و آبهای آلوده

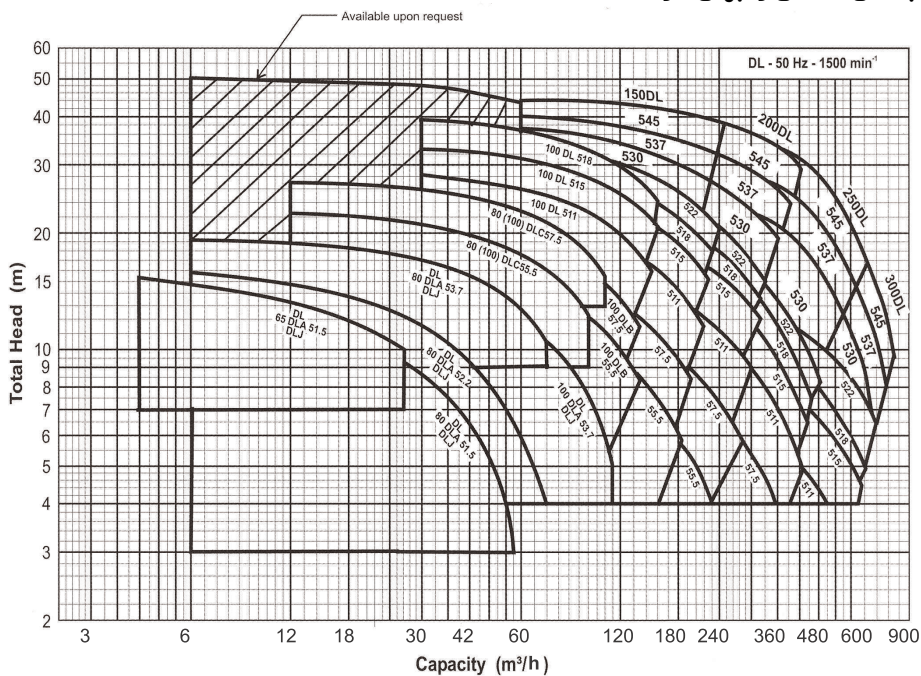

موتور	
1500	دور موتور (rpm)
F	کلاس عایقندی
11-45KW	محافظ حرارتی
تا 7.5KW	محافظ اضافه بار

پمپ		
فاصلاب، آبهای آلوده	نوع مایع	مشخصات سیال
0.4-45 KW	DL, DLA:40	
0.4-3.7 KW	DL J:32	(C°) حداکثر دما
نیمه باز غیر قابل انسداد	پروانه	ساختار
دارای دو مکانیکال سیل	نوع آب بندی	جنس
چدن	پوسته	
چدن	پروانه	
استیل 403 : 1.5-45 KW	شفت	
استیل 420 : 0.4-0.75 KW		

DL Series SUBMERSIBLE SEWAGE PUMPS

جدول ابعادی:

Size DL	Model	Output KW	A	B	C	D	E	F	H	J	L1	CL	Weight
65	65 DL 51.5	1.5	497	291	353	144	265	200	576	200	140	10 m	5-2 kg
80	80 DL 51.5	1.5	524	292	378	146	285	220	597	210	165	10 m	55 kg
	80 DL 52.2	2.2	542	308	388	154	295	220	654	220	165	10 m	67 kg
	80 DL 53.7	3.7	567	328	403	164	310	220	687	235	165	10m	75 kg
	80 DL 55.5	5.5	618	379	428	190	335	307	753	260	205	10m	134kg
100	80 DLC 57.5	7.5	648	399	448	200	355	305	751	280	205	10 m	148 kg
	100 DL 53.7	3.7	614	335	445	169	340	250	706	235	185	10 m	79 kg
	100 DLB 55.5	5.5	646	369	460	186	355	323	768.	250	205	10m	123 kg
	100 DLC 55.5	5.5	660	379	470	190	365	322	753	260	205	10 m	134 kg
	100 DL 57.5	7.5	673	385	480	193	375	323	760	270	205	10 m	141 kg
	100 DLC 57.5	7.5	690	399	490	200	385	320	751	280	205	10m	148 kg
	100 DL 511	11	701	402	500	201	395	323	859	290	205	10m	180kg
	100 DL 515	15	741	441	520	221	415	330	954	310	205	10 m	230 kg
150	100 DL 518	18.5	741	441	520	221	415	330	958	310	205	10m	285 kg
	150 DL 55.5	5.5	750	398	550	200	410	381	799	280	245	10m	146 kg
	150 DL 57.5	7.5	780	418	570	210	430	377	784	300	245	10 m	158 kg
	150 DL 511	11	810	438	590	220	450	377	883	320	245	10 m	199 kg
	150 DL 515	15	810	438	590	220	450	377	972	320	245	10 m	237 kg
	150 DL 518	18.5	848	476	610	238	470	381	979	340	245	10m	300 kg
	150 DL 522	22	848	476	610	238	470	381	979	340	245	10 m	325 kg
	150 DL 530	30	912	520	650	262	510	468	1284	360	1080	10 m	350kg
200	150 DL 537	37	912	520	650	262	510	468	1404	360	1135	10 m	350 kg
	150DL545	45	912	520	650	262	510	468	1404	360	1135	10m	350 kg
	200 DL 55.5	5.5	832	430	615	217	450	414	826	300	285	10 m	160 kg
	200 DL 57.5	7.5	863	453	635	228	470	410	809	320	285	10m	176 kg
	200 DL 511	11	863	453	635	228	470	410	908	320	285	10 m	212 kg
	200 DL 515	15	896	479	655	241	490	411	995	340	285	10 m	260 kg
	200 DL 518	18.5	932	512	675	257	510	415	1001	360	285	10 m	305 kg
	200 DL 522	22	932	512	675	257	510	415	1001	360	285	10 m	330 kg
250	200DL530	30	937	520.	675	262	510	483	1284	360	1080	10 m	350kg
	200 DL 537	37	937	520	675	262	510	483	1404	360	1135	10 m	370 kg
	200 DL 545	45	937	520	675	262	510	483	1404	360	1135	10m	370 kg
	250 DL 57.5	7.5	969	525	700	269	500	622	904	370	400	10 m	260 kg
	250 DL 511	11	993	541	720	273	520	634	1000	390	400	10 m	320 kg
	250 DL 515	15	1007	549	730	277	530	646	1086	400	400	10 m	380 kg
	250 DL 518	18.5	1007	549	730	277	530	646	1089	400	400	10 m	420 kg
	250 -DL 522	22	1007	549	730	277	530	646	1089	400	400	10 m	440 kg
300	250 DL 530	30	1125	660	790	335	590	706	1336	460	1132	10m	458kg
	250 DL 537	37	1125	660	790	335	590	706	1475	460	1206	10m	522kg
	250 DL 545	45	1125	660	790	335	590	706	1475	460	1206	10 m	540kg
	300 DL 511	11	1100	588	798	302	575	671	1050	420	450	10 m	365 kg
	300 DL 515	15	1100	588	798	302	575	671	1131	420	450	10m	395 kg
	300 DL 518	18.5	1135	618	818	317	595	668	1131	440	450	10m	440 kg
	300 DL 522	22	1135	618	818	317	595	668	1131	440	450	10m	465 kg
	300 DL 530	30.	1172	660	838	335	615	726	1336	460	1132	10m	458kg
300	300 DL 537	37	1172	660	838	335	615	726	1475	460	1206	10 m	522kg
	300 DL 545	45	1172	660	838	335	615	726	1475	460	1206	10 m	540kg

FAMCO

هایپر صنعت

Symbol of the dynamism
in industry

Tel: ۳۳۱۱۳۳۷۷ (خط ۳۰)
E-mail: info@famco.co.ir
www.famcocorp.com
www.famco.co.ir

تهران - کیلومتر ۲۱ جاده مخصوص کرج - روبروی پالایشگاه
نفت پارس، پلاک ۱۲
تهران - خیابان سعدی جنوبی - مجتمع اداری تجاری سعدی
طبقه ششم - واحد ۶۱۷

نماد پویایی در صنعت