



LENNTECH
WATER TREATMENT SOLUTIONS

info@lennotech.com Tel. +31-152-610-900
www.lennotech.com Fax. +31-152-61289

	Page
- SPECIFICATIONS	200
SELECTION CHART	201
TYPE KEY AND CURVE SPECIFICATIONS	211
PERFORMANCE CURVE ENR 32-125	213
PERFORMANCE CURVE ENR 32-160A	214
PERFORMANCE CURVE ENR 32-160B	215
PERFORMANCE CURVE ENR 32-200A	216
PERFORMANCE CURVE ENR 32-200B	217
PERFORMANCE CURVE ENR 32-250	218
PERFORMANCE CURVE ENR 40-125	219
PERFORMANCE CURVE ENR 40-160	220
PERFORMANCE CURVE ENR 40-200	221
PERFORMANCE CURVE ENR 40-250	222
PERFORMANCE CURVE ENR 40-315	223
PERFORMANCE CURVE ENR 50-125	224
PERFORMANCE CURVE ENR 50-160	225
PERFORMANCE CURVE ENR 50-200	226
PERFORMANCE CURVE ENR 50-250	227
PERFORMANCE CURVE ENR 50-315	228
PERFORMANCE CURVE ENR 65-125	229
PERFORMANCE CURVE ENR 65-160	230
PERFORMANCE CURVE ENR 65-200	231
PERFORMANCE CURVE ENR 65-250	232
PERFORMANCE CURVE ENR 80-160	233
PERFORMANCE CURVE ENR 80-200	234
PERFORMANCE CURVE ENR 80-250	235
PERFORMANCE CURVE ENR 100-160	236
PERFORMANCE CURVE ENR 100-200	237
PERFORMANCE CURVE ENR 100-250	238
PERFORMANCE CURVE ENR 125-200	239
- CONSTRUCTIONS	300
SECTIONAL VIEW	300

CONTENTS

50Hz

Rev. 0

- DIMENSIONS AND WEIGHT	400
PUMP WITH MOTOR 32-40	400
PUMP WITH MOTOR 40-50	401
PUMP WITH MOTOR 65-80-100	402
PUMP WITH MOTOR 100-125	403
PUMP WITHOUT MOTOR	404
- TECHNICAL DATA	500
MOTOR DATA 32-40-50	500
MOTOR DATA 50-65	501
MOTOR DATA 80-100-125	502
NOISE DATA	503

SPECIFICATION

50Hz

Rev. 0

PUMP		
Liquid Handled	Type of liquid	Clean water
	Temperature [°C]	min. -20°C max +120°C
Maximum working pressure	[MPa]	1.47
Flange		UNI 2236
Counterflange (On request)		UNI 2247
Construction	Impeller	Closed centrifugal type
	Shaft seal type	Mechanical seal
	Bearing	Sealed ball bearing
Pipe Connection	Suction	Flange to DIN 2532
	Discharge	Flange to DIN 2532
Material	Casing	CAST IRON
	Impeller	CAST IRON / BRONZE
	Shaft seal	SiC/Carbon/EPDM
	Shaft	AISI 420
	Bracket	CAST IRON
Applicable standard of test		ISO 9906 – Annex A

MOTOR		
Type	Electric - TEFC Three Phase	
Efficiency level (Reg. 640/2009)	IE2	
No. of Poles	2	
Rotation speed [min ⁻¹]	≈2900	
Insulation Class	F	
Protection degree (CEI EN 60034-5)	IP 55	
Power rating	[kW]	0.75 ÷ 110
	[HP]	1 ÷ 150
Frequency [Hz]	50	
Voltage [V]	400/690 ±10%	
Over load protection	Provided by the user	
Casing material	Cast Iron	

SELECTION CHART

50Hz

Rev. 0

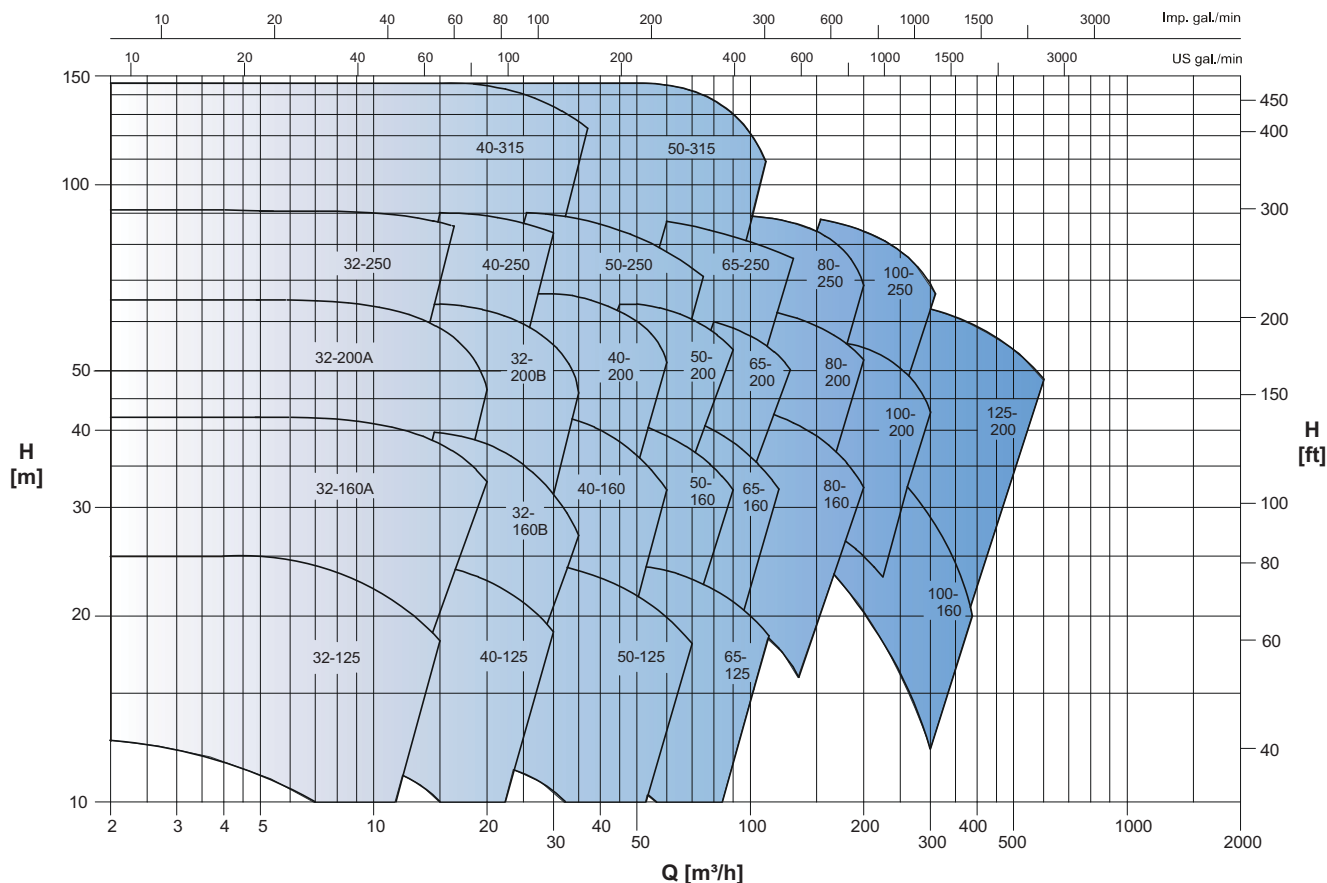

ENR 2 Poles: 32-125 Version

Pump type ENR	Q=Capacity											
	m ³ /h 0	2	4	6	8	10	12	14	16	18	20	22
Three Phase	l/min 0	33,3	67	100	133	167	200	233	267	300	333	367
	H=Total manometric head in meters											
ENR 32-125 Ø100	11,5	11,4	11	10,8	10,5	9,8	8	6	-	-	-	-
ENR 32-125 Ø110	14,5	14,5	14,3	14	13,8	12,8	11,8	10	8	-	-	-
ENR 32-125 Ø120	17,5	17,5	17,3	17,1	16,9	16	15	13,8	12	10	-	-
ENR 32-125 Ø130	22	22	22	21,9	21,7	21,2	20	18,8	17,7	15,3	13	-
ENR 32-125 Ø140	26	26	26	26	25,9	25,3	25	24	22,9	21	18,4	16

SELECTION CHART

50Hz

Rev. 0

ENR 2 Poles: 32-160 A Version

Pump type ENR	Q=Capacity												
	m ³ /h 0	2	4	6	8	10	12	13,5	15,2	16,8	18	19,5	20,5
Three Phase	l/min 0	33,3	67	100	133	167	200	225	253	280	300	325	342
H=Total manometric head in meters													
ENR 32-160A Ø130	22,5	22,5	22,5	22,4	21	19,9	17,4	15	-	-	-	-	-
ENR 32-160A Ø140	27	26,9	26,5	25,5	24,5	24,5	22,5	20	17,5	-	-	-	-
ENR 32-160A Ø150	30,5	30,7	30,6	30,2	29,5	29,5	27,5	25,5	22,5	20	-	-	-
ENR 32-160A Ø160	35,5	35,8	36	35,4	34,5	34,8	33	31,5	28,5	26,5	23	-	-
ENR 32-160A Ø168	40	41	40,5	40	39,8	39,7	37,8	37	35	32,5	30	27	-
ENR 32-160A Ø175	44,5	45	45	45	44,5	43,5	42,5	41	39	37,5	35	32,5	31

ENR 2 Poles: 32-160 B Version

Pump type ENR	Q=Capacity										
	m ³ /h 0	5	10	15	20	24,5	27	29	32	34	36
Three Phase	l/min 0	83,3	167	250	333	408	450	483	533	567	600
H=Total manometric head in meters											
ENR 32-160B Ø130	22,3	22,4	21,5	20	17,5	15	-	-	-	-	-
ENR 32-160B Ø140	26,3	26,4	25,7	24,5	24,9	18,5	17,5	-	-	-	-
ENR 32-160B Ø150	30	30,2	30	28,5	27	26	22	20	-	-	-
ENR 32-160B Ø160	35	35	34,8	33,5	31,5	28	27	25	22,5	-	-
ENR 32-160B Ø168	39	38,8	38,5	37,5	35,5	35,2	31,5	29	27,3	25	-
ENR 32-160B Ø175	42,5	42,5	42,5	42	40	37,5	35,3	33	31,5	28	27,5

ENR 2 Poles: 32-200 A Version

Pump type ENR	Q=Capacity												
	m ³ /h 0	3	7	10	12	14	15	18	19	21	22,5	23	24
Three Phase	l/min 0	50	117	167	200	233	250	300	317	350	375	383	400
H=Total manometric head in meters													
ENR 32-200A Ø170	37	36	35,5	34	33	31	30	27	-	-	-	-	-
ENR 32-200A Ø180	42	42	41,5	40	38	37	36	33	30	-	-	-	-
ENR 32-200A Ø190	48	48	47	46	45	44	42	39	37	35	-	-	-
ENR 32-200A Ø200	55	55	54	53,5	52	51	50	46	44	42	39	-	-
ENR 32-200A Ø207	60	60	59	58	57	56	55	52	51	47	45	42,5	-
ENR 32-200A Ø214	65	66	65	64	63	62	61	58	56	53,5	50	48	46

SELECTION CHART

50Hz

Rev. 0

ENR 2 Poles: 32-200 B Version

Pump type ENR	Q=Capacity										
	m ³ /h 0	5	10	15	20	25	26,9	29	31,5	33	35
Three Phase	l/min 0	83,3	167	250	333	417	448	483	525	550	583
H=Total manometric head in meters											
ENR 32-200B Ø170	37	37	36	35	32,5	26	-	-	-	-	-
ENR 32-200B Ø180	44	43,5	43	42	40	34	32	-	-	-	-
ENR 32-200B Ø190	49	48,5	48	47	46	42	40	35	-	-	-
ENR 32-200B Ø200	56	55	55	54	53,5	50	48	44	41	-	-
ENR 32-200B Ø207	61	61	60,5	60	59	56	54	52	48	45	-
ENR 32-200B Ø214	67	66,5	65,5	65,5	65	63	61	58	56	53	50

ENR 2 Poles: 32-250 Version

Pump type ENR	Q=Capacity											
	m ³ /h 0	4	8	10	12	14	16	18	19,1	19,9	21	21,5
Three Phase	l/min 0	66,7	133	167	200	233	267	300	318	332	350	358
H=Total manometric head in meters												
ENR 32-250 Ø215	56,5	55	55	54	52	49	45	39	-	-	-	-
ENR 32-250 Ø225	65	65	64	62,5	60	58	54	48,5	45	-	-	-
ENR 32-250 Ø235	72,5	72,5	71	70	68	65	62	57	54	52,5	-	-
ENR 32-250 Ø245	80	80	80	79	77	75	72	67	65	61	60	-
ENR 32-250 Ø255	90	90	89	88	87	85	82	77	75	71	69	68

ENR 2 Poles: 40-125 Version

Pump type ENR	Q=Capacity										
	m ³ /h 0	5	10	15	20	25	26,5	28	30	33	36
Three Phase	l/min 0	83,3	167	250	333	417	442	467	500	550	600
H=Total manometric head in meters											
ENR 40-125 Ø100	12	11,9	11,8	10,2	9	5,8	4,2	-	-	-	-
ENR 40-125 Ø110	14,2	14,2	14	13,8	12	8,7	8	7	-	-	-
ENR 40-125 Ø120	17,9	17,9	17,8	16,2	15,8	13	12	11	9,8	-	-
ENR 40-125 Ø130	22	22	22	21,8	20	18	17,5	16,2	14,8	12,5	-
ENR 40-125 Ø140	26	26,1	26	26	25	23,8	22,6	21	20,2	18	15

203

SELECTION CHART

50Hz

Rev. 0

ENR 2 Poles: 40-160 Version

Pump type ENR Three Phase	Q=Capacity												
	m ³ /h 0	10	15	20	25	30	35	42	47	52	57	62	65
	l/min 0	166,7	250	333	417	500	583	700	783	867	950	1033	1083
H=Total manometric head in meters													
ENR 40-160 Ø130	22,5	22,5	22,3	22	21	20	17,6	15	-	-	-	-	-
ENR 40-160 Ø140	27	27	26,5	25,5	25	24,8	22,5	20	17,5	-	-	-	-
ENR 40-160 Ø150	31,5	31	30,5	30	29,9	28,5	27,5	25,5	23	21	-	-	-
ENR 40-160 Ø160	36	35,4	35	35	34,9	33	32,5	31,5	28,5	27	24	-	-
ENR 40-160 Ø168	39,5	39,8	39,5	39	38	37,5	36,5	35	33	32	30	26,5	-
ENR 40-160 Ø175	43	43	42,5	42,5	42	41,5	41	39,5	37,5	35,5	33	30,5	26

ENR 2 Poles: 40-200 Version

Pump type ENR Three Phase	Q=Capacity												
	m ³ /h 0	10	15	20	27,5	35	42,5	47,5	52	55	59	62,5	65
	l/min 0	166,7	250	333	458	583	708	792	867	917	983	1042	1083
H=Total manometric head in meters													
ENR 40-200 Ø170	39,8	40	39,9	39,5	38,5	36	33	30	-	-	-	-	-
ENR 40-200 Ø180	45,5	45,5	45,5	45,5	45	43,5	40	37,5	35	-	-	-	-
ENR 40-200 Ø190	53	52,5	52,5	52	51,5	50	48	45	42,5	40	-	-	-
ENR 40-200 Ø200	58	58	57,5	57	57	56,5	55	52,5	50	47	44	-	-
ENR 40-200 Ø207	63	63	62,5	62,5	62	61,5	60	58	55	53	50	48	-
ENR 40-200 Ø214	68	68	67,5	67,5	67	66,5	65	63	60	58	56	54	52

ENR 2 Poles: 40-250 Version

Pump type ENR Three Phase	Q=Capacity											
	m ³ /h 0	5	10	15	20	25	30	32,5	35	37	39	42
	l/min 0	83,3	167	250	333	417	500	542	583	617	650	700
H=Total manometric head in meters												
ENR 40-250 Ø215	60,5	60	60	59	56	53	48	45	-	-	-	-
ENR 40-250 Ø225	68	67	66	65	64	60,5	56	53	50	-	-	-
ENR 40-250 Ø235	74	74	74	73	72	69	65	62	59,5	56	-	-
ENR 40-250 Ø245	82	82	82	81	80	78	74	71	69,5	65	63	-
ENR 40-250 Ø255	91	90,5	90	90	89	87	84	81	79,5	76	74	70

SELECTION CHART

50Hz

Rev. 0

ENR 2 Poles: 40-315 Version

Pump type ENR	Q=Capacity											
	m ³ /h 0	5	10	15	20	25	29	31	33	37,5	40	42,5
Three Phase	l/min 0	83,3	167	250	333	417	483	517	550	625	667	708
H=Total manometric head in meters												
ENR 40-315 Ø270	91	91	90	90	88	78	69	-	-	-	-	-
ENR 40-315 Ø 285	105	104	103	102	100	92	84	79	-	-	-	-
ENR 40-345 Ø295	115	114	113	112	110	105	99	92	88	-	-	-
ENR 40-315 Ø305	126	125	123	122	120	118	110	107	100	91	-	-
ENR 40-315 Ø315	135	134	133	132	131	128	123	120	117	107	100	-
ENR 40-315 Ø325	146	146	145	144	143	141	138	132	130	122	118	110

ENR 2 Poles: 50-125 Version

Pump type ENR	Q=Capacity										
	m ³ /h 0	5	10	20	30	35	40,5	45,5	51	58	66,5
Three Phase	l/min 0	83,3	167	333	500	583	675	758	850	967	1108
H=Total manometric head in meters											
ENR 50-125 Ø100	11,8	11,7	11,2	10	8	6	4	-	-	-	-
ENR 50-125 Ø110	14,4	14,5	14	13,9	12	10	8,2	6,8	-	-	-
ENR 50-125 Ø120	17,5	17,9	17,9	17,8	16	15	13,9	12	9,9	-	-
ENR 50-125 Ø130	21,5	21,8	21,8	21,7	20,8	20	19	18	16	13	-
ENR 50-125 Ø140	26	26	26	26	25,9	25,7	24,8	24	22,8	20	16,4

ENR 2 Poles: 50-160 Version

Pump type ENR	Q=Capacity										
	m ³ /h 0	10	20	30	45	55	70	77	84	92	100
Three Phase	l/min 0	166,7	333	500	750	917	1167	1283	1400	1533	1667
H=Total manometric head in meters											
ENR 50-160 Ø130	21	21	20,5	20	18	16,5	12	-	-	-	-
ENR 50-160 Ø 140	26	26	25	25	23,5	22,5	18,5	16,5	-	-	-
ENR 50-160 Ø150	31	31	30	30	28	27,5	24	22,5	20	-	-
ENR 50-160 Ø160	36	36	35,5	35	34	32,5	30	28,5	26	24	-
ENR 50-160 Ø175	42	42	42	42	41	40	37,5	36	33	31,5	29

205

SELECTION CHART

50Hz

Rev. 0

ENR 2 Poles: 50-200 Version

Pump type ENR Three Phase	Q=Capacity											
	m ³ /h 0	10	20	30	50	70	74	77	83	90	92,5	95
	l/min 0	166,7	333	500	833	1167	1233	1283	1383	1500	1542	1583
	H=Total manometric head in meters											
ENR 50-200 Ø170	40	40	40	39	36	30	29	-	-	-	-	-
ENR 50-200 Ø180	46	46	45,5	45	42	36	35	33,8	-	-	-	-
ENR 50-200 Ø190	52	52	51,5	50	48	42	42	40	38	-	-	-
ENR 50-200 Ø200	57,5	57	56,5	56	54	50	48	47	44	43	-	-
ENR 50-200 Ø207	61,5	61	61	60,5	58	54	53,5	52	50	48	47	-
ENR 50-200 Ø214	65,5	65,5	65,5	65	62,5	59	58	56,5	55	53	52	52

ENR 2 Poles: 50-250 Version

Pump type ENR Three Phase	Q=Capacity									
	m ³ /h 0	20	30	40	50	55,0	61	68	74	79
	l/min 0	333,3	500	667	833	917	1017	1133	1233	1317
	H=Total manometric head in meters									
ENR 50-250 Ø215	60,5	60	58	56	50	48	-	-	-	-
ENR 50-250 Ø225	68	67	65	62,5	58	56	52	-	-	-
ENR 50-250 Ø235	75	74	72	70	66	63,5	59	55	-	-
ENR 50-250 Ø245	82,5	82	80	78	75	74	70	64	60	-
ENR 50-250 Ø255	90,5	90	89	87,5	84	82,5	79	75	70	66

ENR 2 Poles: 50-315 Version

Pump type ENR Three Phase	Q=Capacity											
	m ³ /h 0	10	20	30	40	50	70	74	84	92	99	105
	l/min 0	166,7	333	500	667	833	1167	1233	1400	1533	1650	1750
	H=Total manometric head in meters											
ENR 50-315 Ø270	98	97,5	97	96,5	95	92	70	65	-	-	-	-
ENR 50-315 Ø285	112	112	111	110,5	110	107	92	85	72	-	-	-
ENR 50-315 Ø300	125	125	125	125	125	124	113	107	92	80	-	-
ENR 50-315 Ø313	140	140	139,5	139	138	137	130	125	112	100	85	-
ENR 50-315 Ø325	152	152	151	152	151	150	145	141	132	120	105	90

SELECTION CHART

50Hz

Rev. 0

ENR 2 Poles: 65-125 Version

Pump type ENR	Q=Capacity										
	m ³ /h 0	20	30	40	50	60	80	87	102	120	140
Three Phase	l/min 0	333	500	667	833	1000	1333	1450	1700	2000	2333
H=Total manometric head in meters											
ENR 65-125 Ø110	14	13,9	13,8	13	12	10,5	7	5	-	-	-
ENR 65-125 Ø120	17,5	17	16,3	16	15	14	11,8	10	7	-	-
ENR 65-125 Ø130	21	20,7	20,5	20	19,5	18,5	16	15	12	8	-
ENR 65-125 Ø143	26,5	26,4	26,3	26,2	26	25,5	24	23	20,5	17	12

ENR 2 Poles: 65-160 Version

Pump type ENR	Q=Capacity										
	m ³ /h 0	20	40	60	80	97	107	119	130	140	150
Three Phase	l/min 0	333	667	1000	1333	1617	1783	1983	2167	2333	2500
H=Total manometric head in meters											
ENR 65-160 Ø130	20,5	20	20	18	15	10,5	-	-	-	-	-
ENR 65-160 Ø140	25	25	24,5	22,5	20	15,5	12,5	-	-	-	-
ENR 65-160 Ø150	29	29	28	27,5	25	21	17,5	15	-	-	-
ENR 65-160 Ø160	34	34	33,5	33	31,5	27,5	25	22	17,5	-	-
ENR 65-160 Ø168	38	38	37,5	37,5	35,5	32,5	30	27,5	24,5	20	-
ENR 65-160 Ø175	42	42	42	41,5	40	37,5	35,5	32,5	30	27	23

ENR 2 Poles: 65-200 Version

Pump type ENR	Q=Capacity										
	m ³ /h 0	20	40	60	80	100	110	120	130	137	143
Three Phase	l/min 0	333,3	667	1000	1333	1667	1833	2000	2167	2283	2383
H=Total manometric head in meters											
ENR 65-200 Ø170	37	36,5	35,5	33	29	24	-	-	-	-	-
ENR 65-200 Ø180	43	42	41,5	39	36	31	28	-	-	-	-
ENR 65-200 Ø190	48	48	47	46	42,5	38	35	32	-	-	-
ENR 65-200 Ø200	53	53	53	52	50	46	44	40	38	-	-
ENR 65-200 Ø207	58	58	57	56	54	52	49	46	43	41	-
ENR 65-200 Ø214	62	62	62	61	60	57	55	52	49	46,5	44

SELECTION CHART

50Hz

Rev. 0

ENR 2 Poles: 65-250 Version

Pump type ENR Three Phase	Q=Capacity											
	m ³ /h 0	20	40	50	70	80	100	120	125	132	140	145
	l/min 0	333,3	667	833	1167	1333	1667	2000	2083	2200	2333	2417
	H=Total manometric head in meters											
ENR 65-250 Ø215	57,5	57	56	55,5	55	52,5	49	42,5	-	-	-	-
ENR 65-250 Ø225	64,5	64	64,0	63,5	62	60	57	52	50	-	-	-
ENR 65-250 Ø235	72	72	71,5	71	70	69	65,5	60	59	55	-	-
ENR 65-250 Ø245	81	80,5	80	80	79	78	75	70	68	65	64	-
ENR 65-250 Ø255	90	90	89	89	88	87	84	80	78	75	72,5	70

ENR 2 Poles: 80-160 Version

Pump type ENR Three Phase	Q=Capacity											
	m ³ /h 0	20	40	60	80	100	140	145	163	180	197	210
	l/min 0	333,3	667	1000	1333	1667	2333	2417	2717	3000	3283	3500
	H=Total manometric head in meters											
ENR 80-160 Ø130	20,3	20	20	19	17,5	17	11	-	-	-	-	-
ENR 80-160 Ø140	24	23,5	23	22,5	22,5	21,5	16	14	-	-	-	-
ENR 80-160 Ø150	28,5	27,9	27,8	27,7	27,5	26	22,5	20	17,5	-	-	-
ENR 80-160 Ø160	33	32,5	32,5	32,6	32,5	31,5	28	27	24,5	22,5	-	-
ENR 80-160 Ø168	37,7	37,5	37,5	37,5	37,5	37	34	32,5	30,2	27,5	25	-
ENR 80-160 Ø175	42,5	42,5	42,5	42,5	42	42	38,5	37,5	36,5	34,5	30	27,5

ENR 2 Poles: 80-200 Version

Pump type ENR Three Phase	Q=Capacity											
	m ³ /h 0	20	40	60	80	100	150	166	178	190	204	220
	l/min 0	333,3	667	1000	1333	1667	2500	2767	2967	3167	3400	3667
	H=Total manometric head in meters											
ENR 80-200 Ø170	35,2	35	35	34	33	31	20	-	-	-	-	-
ENR 80-200 Ø180	41	41	41	40	39	37,5	28	25	-	-	-	-
ENR 80-200 Ø190	47	47	46	45,5	45	44	35	32	29	-	-	-
ENR 80-200 Ø 200	54	54	54	53	52,5	51,5	45	41	38	35	-	-
ENR 80-200 Ø207	59	58,5	58	58	57,5	57	52	50	47	44	40	-
ENR 80-200 Ø214	65	65	65	65	64	64	59	58,5	55	53	50	45,5

SELECTION CHART

50Hz

Rev. 0

ENR 2 Poles: 80-250 Version

Pump type ENR	Q=Capacity											
	m ³ /h 0	20	40	60	80	120	140	170	179	189	198	205
Three Phase	l/min 0	333,3	667	1000	1333	2000	2333	2833	2983	3150	3300	3417
H=Total manometric head in meters												
ENR 80-250 Ø215	55,5	56	55,5	55,5	55	52	48,5	40	-	-	-	-
ENR 80-250 Ø225	64,5	64,5	64,5	64,5	64	60	56	48,5	46	-	-	-
ENR 80-250 Ø235	72,5	72,5	72	72	71,5	68	65	57	55	52	-	-
ENR 80-250 Ø245	82	81	80,5	81	80,5	78	75	68	65	62	59	-
ENR 80-250 Ø255	90	90	90	90	90	88	85	78,5	75	72	69	65,5

ENR 2 Poles: 100-160 Version

Pump type ENR	Q=Capacity							
	m ³ /h 0	100	200	280	300	320	340	375
Three Phase	l/min 0	1667	3333	4667	5000	5333	5667	6250
H=manometric head in meters								
ENR 100-160Ø183(Ø183)	23	23	19	13	-	-	-	-
ENR 100-160 Ø183(Ø173)/Ø183 (Ø167) -5°	26,5	26	22,5	17	15	-	-	-
ENR 100-160 Ø183(Ø165)/Ø183 (Ø155) -7.7°	32	31	27,5	22	20	18	-	-
ENR 100-160 Ø183(Ø158)/Ø183 (Ø142) -11.5°	35	35	32,5	28	27	25	22,5	-
ENR 100-160 Ø183(Ø151)/Ø183 (Ø129) -14.7°	40	40	50	36	35	33	31	27

ENR 2 Poles: 100-200 Version

Pump type ENR	Q=Capacity									
	m ³ /h 0	50	100	150	200	226	250	270	288	312
Three Phase	l/min 0	833,3	1667	2500	3333	3767	4167	4500	4800	5200
H=Total manometric head in meters										
ENR 100-200 Ø170	33,5	32,5	30,5	26	20	15	-	-	-	-
ENR 100-200 Ø180	38	37,5	37	34	29	24,9	21	-	-	-
ENR 100-200 Ø190	44,5	44	44	40,5	36	33	30	25,5	-	-
ENR 100-200 Ø200	50,5	50,5	50	47,5	45	41,5	39	35,5	34	-
ENR 100-200 Ø213	57	57	56,5	55	53	50	48	45,5	42,5	40

SELECTION CHART

50Hz

Rev. 0

ENR 2 Poles: 100-250 Version

Pump type ENR Three Phase	Q=Capacity									
	m ³ /h 0	50	100	150	200	262	275	285	298	312
	l/min 0	833,3	1667	2500	3333	4367	4583	4750	4967	5200
	H=Total manometric head in meters									
ENR 100-250 Ø215	55,5	55	55	52,5	46,5	37,5	-	-	-	-
ENR 100-250 Ø225	65	64,5	63,5	60,5	56	46	44	-	-	-
ENR 100-250 Ø235	71,5	71	70,5	68,5	65	55	51	50	-	-
ENR 100-250 Ø245	80	80	80	78	75	65	62	60	57	-
ENR 100-250 Ø255	89	89	88,5	86,5	84	75,5	74	71	69	66

ENR 2 Poles: 125-200 Version

Pump type ENR Three Phase	Q=Capacity									
	m ³ /h 0	100	200	300	400	450	490	540	580	650
	l/min 0	1667	3333	5000	6667	7500	8167	9000	9667	10833
	H=Total manometric head in meters									
ENR 125-200 Ø180	40,5	40	38	33	25	20	-	-	-	-
ENR 125-200 Ø190	46	45	44	40	34	29,9	25	-	-	-
ENR 125-200 Ø200	50	50	50	47,5	43	40	35	30	-	-
ENR 125-200 Ø210	56,5	56	55	55	51	48	45	42	37	-
ENR 125-200 Ø220	62	62	61	60	58	56	54	52	48	43

TYPE KEY AND CURVE SPECIFICATIONS

50Hz

Rev. 0

TYPE KEY:

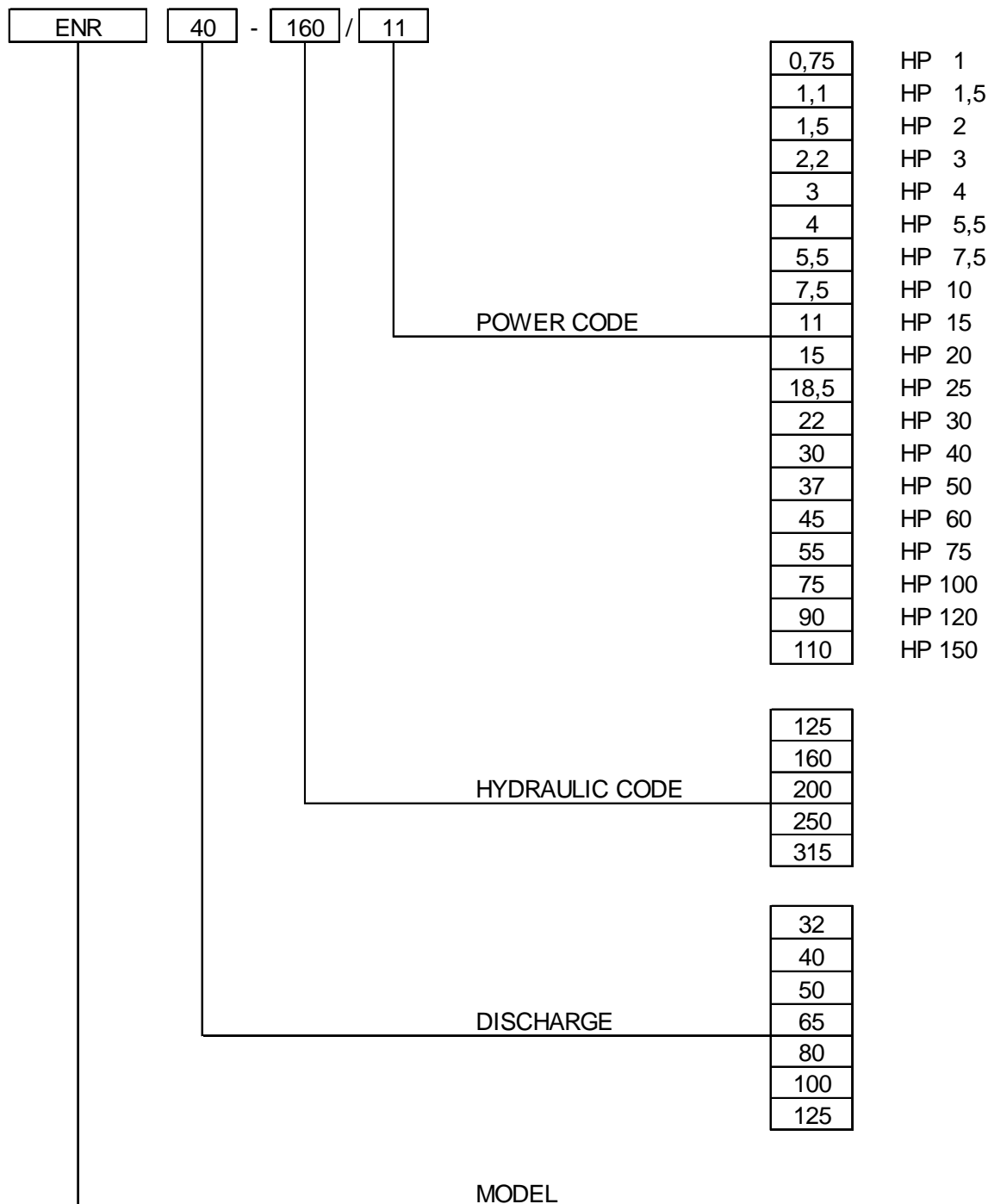

PERFORMANCE CURVE SPECIFICATIONS

The specifications below qualify the curves shown on the following pages.

Tolerances according to ISO 9906 Annex A

The curves refer to effective speed of asynchronous motors at 50 Hz

Measurements were carried out with clean water at 20°C of temperature and with a kinematic viscosity of $\nu = 1 \text{ mm}^2/\text{s}$ (1 cSt)

The NPSH curve is an average curve obtained in the same conditions of performance curves.

The continuous curves indicate the recommended working range. The dotted curve is only a guide.

In order to avoid the risk of over-heating, the pumps should not be used at a flow rate below 10% of best efficiency point.

Symbols explanation:

- Q = volume flow rate
- H = total head
- P_2 = pump power input (shaft power)
- η = pump efficiency
- NPSH = net positive suction head required by the pump
- MEI = minimum efficiency index

The minimum efficiency index (MEI) is a measure of the quality of a pump size in respect to its mean efficiency. The minimum efficiency index is based on the hydraulic efficiency and on the head at the best efficiency point.

The efficiency of a pump with trimmed impeller is usually lower than that of a pump with the full impeller diameter. The trimming of the impeller will adapt the pump to a fixed duty point, leading to reduced energy consumption. The minimum efficiency index (MEI) is based on the full impeller diameter.

The operation of these water pumps with variable duty points may be more efficient and economic when controlled, for example, by the use of a variable speed drive that matches the pump duty to the system.

MEI = 0.4 for ESOB 2900 rpm

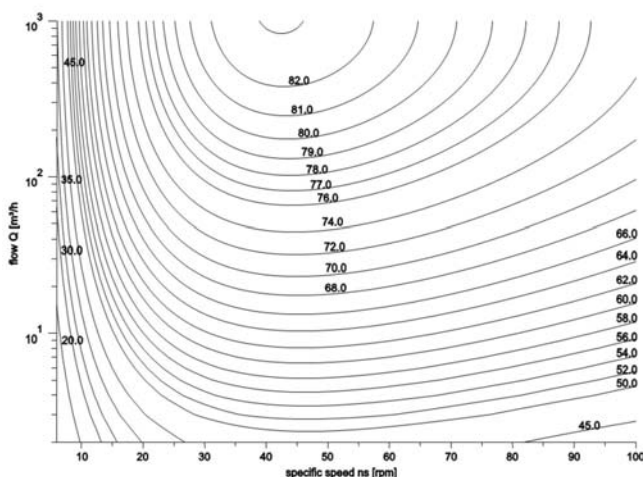

MEI = 0.7 for ESOB 2900rpm

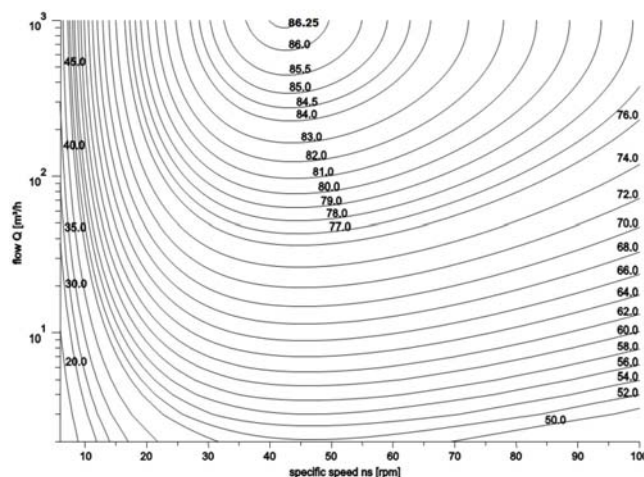

ENR 32-125 MEI > 0.40

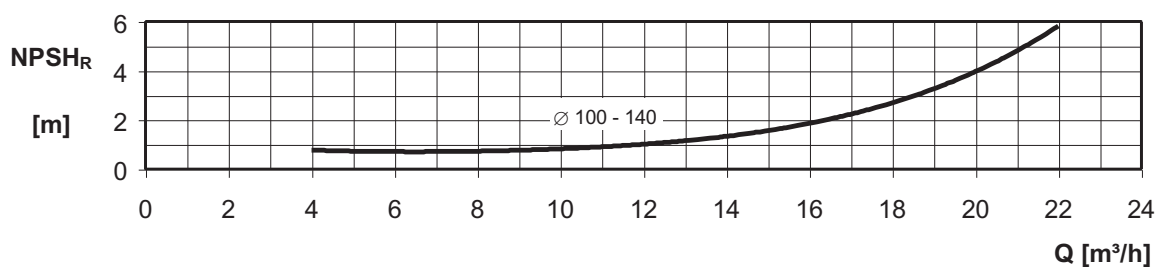
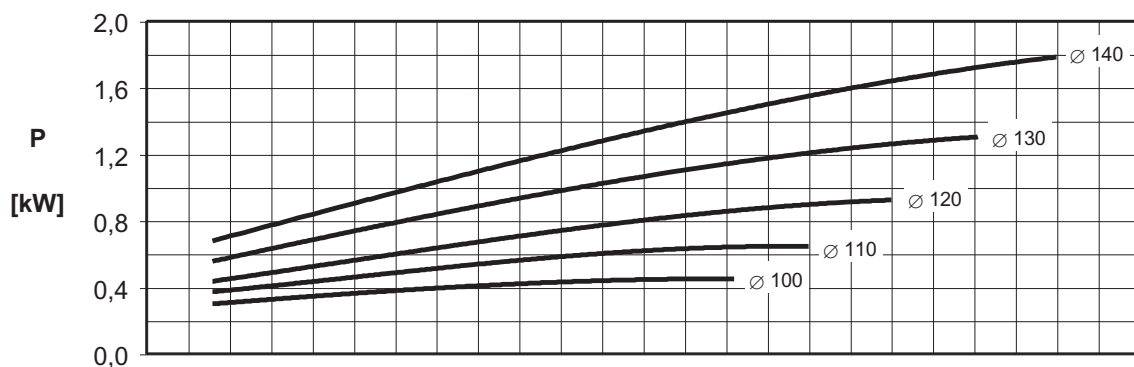
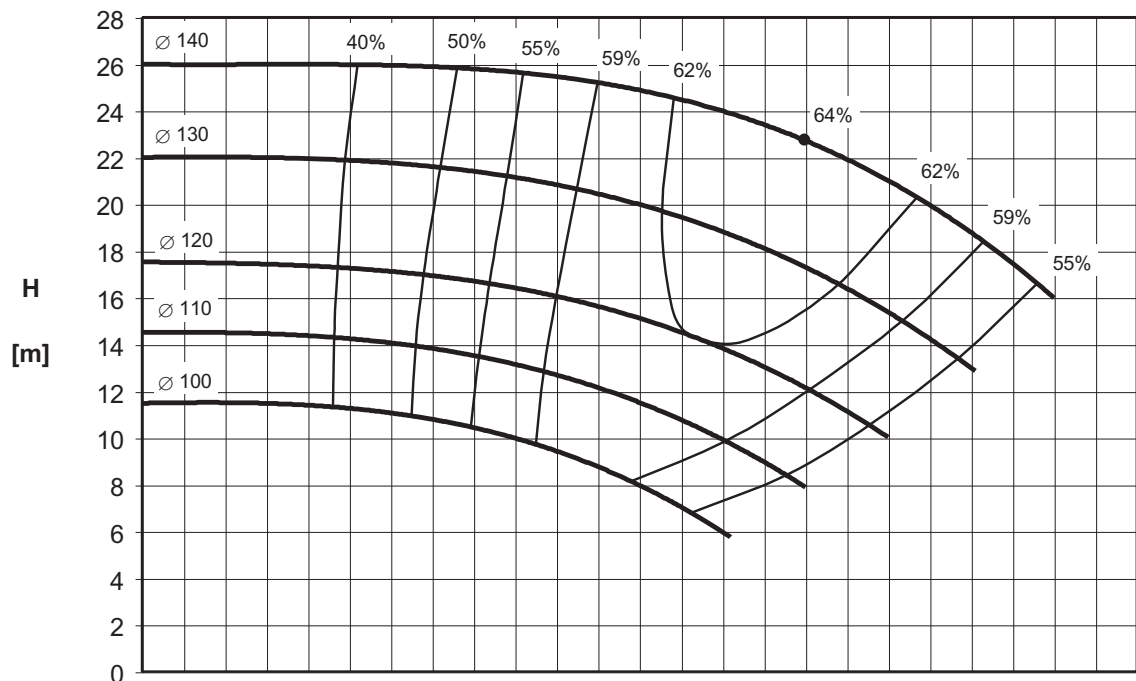

Rotation speed $\approx 2900 \text{ min}^{-1}$
Test standard: ISO 9906 – Annex A

PERFORMANCE CURVE

50Hz

Rev. 0

ENR 32-160A MEI > 0.40

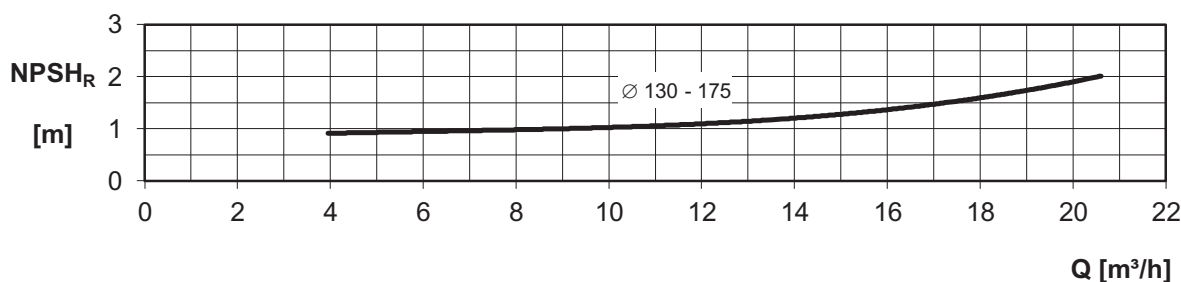
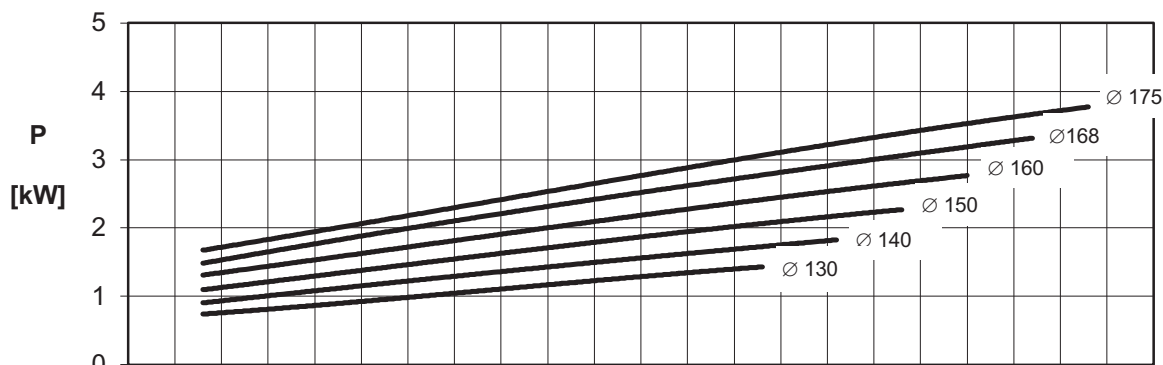
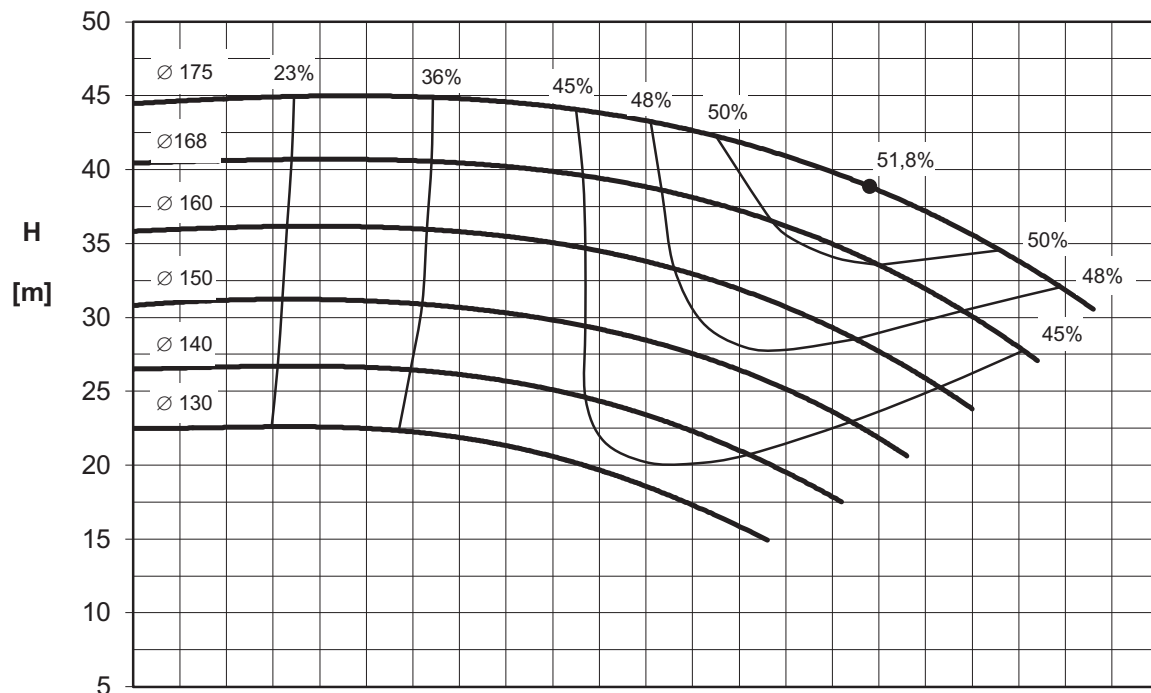

Rotation speed $\approx 2900 \text{ min}^{-1}$
Test standard: ISO 9906 – Annex A

PERFORMANCE CURVE

50Hz

Rev. 0

ENR 32-160B MEI > 0.40

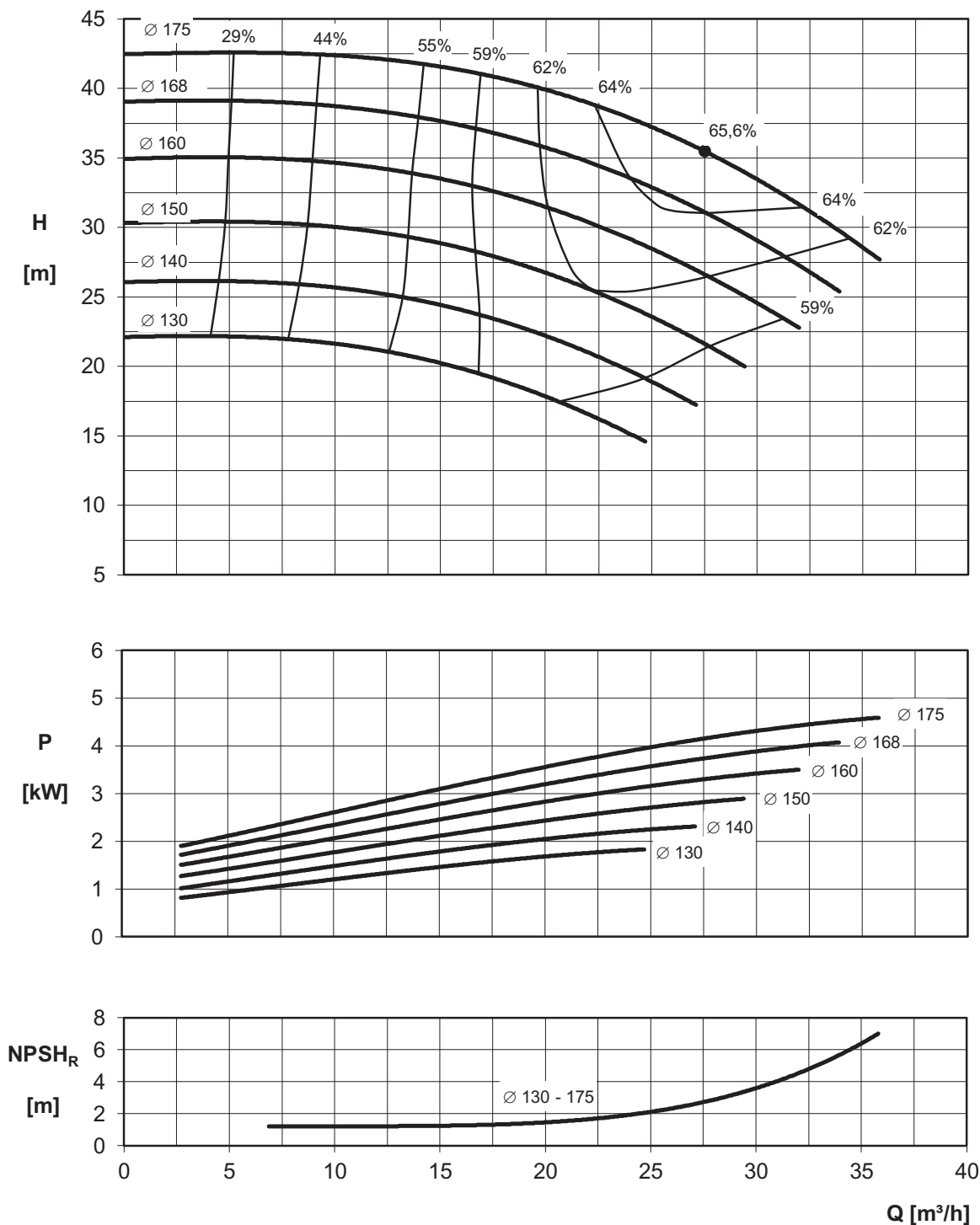

Rotation speed $\approx 2900 \text{ min}^{-1}$
Test standard: ISO 9906 – Annex A

PERFORMANCE CURVE

50Hz

Rev. 0

ENR 32-200A MEI > 0.40

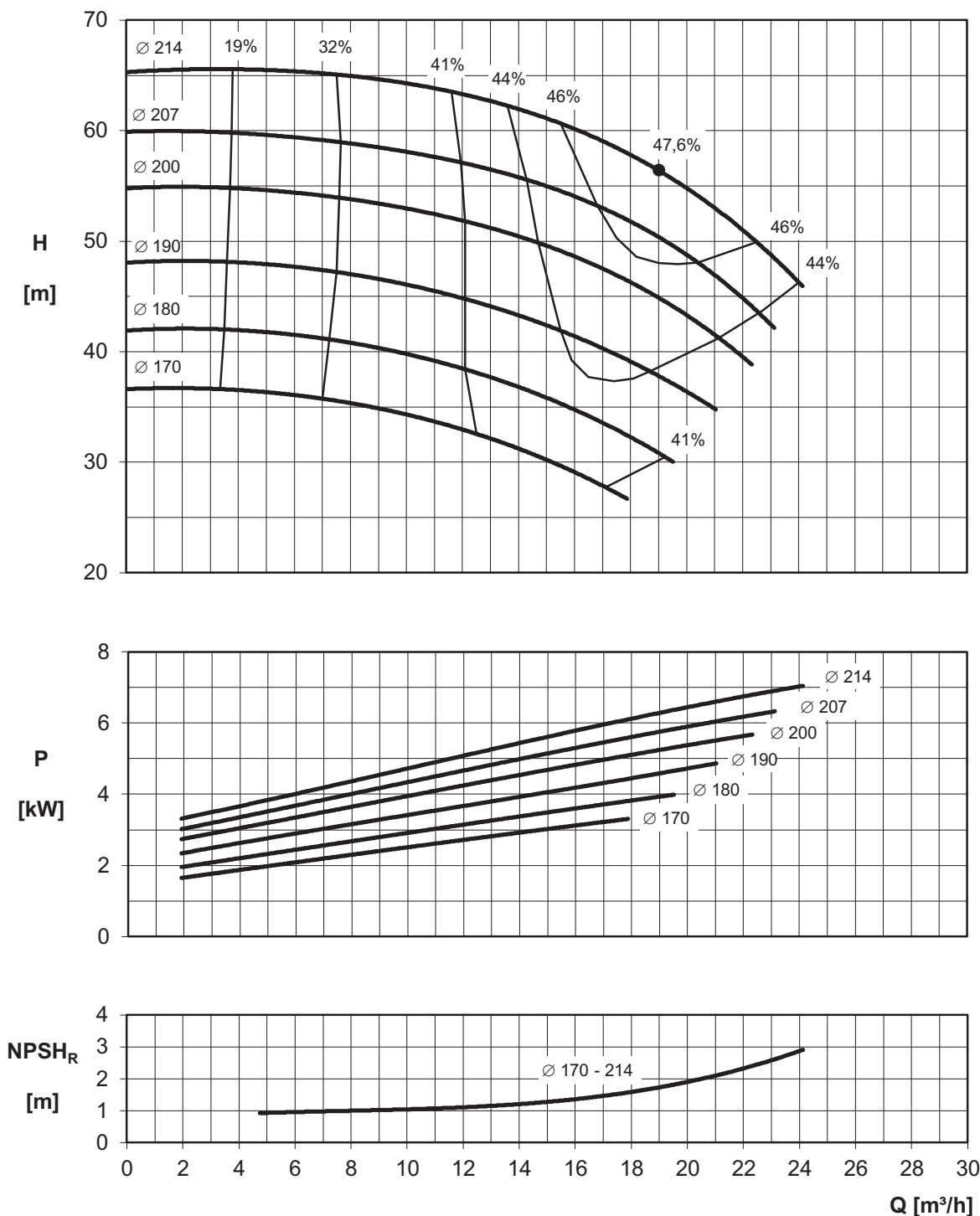

Rotation speed $\approx 2900 \text{ min}^{-1}$
Test standard: ISO 9906 – Annex A

ENR 32-200B MEI > 0.40

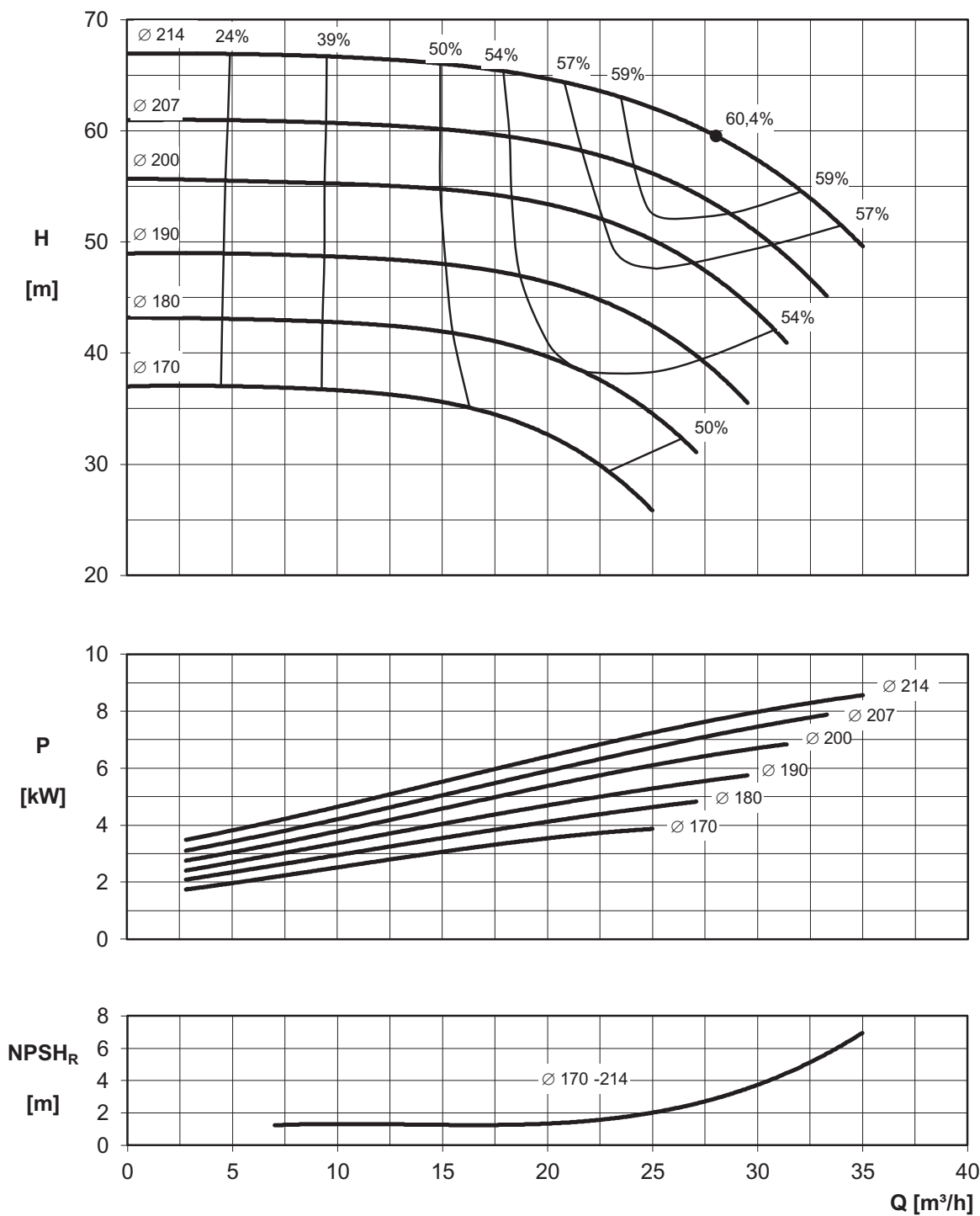

Rotation speed $\approx 2900 \text{ min}^{-1}$
Test standard: ISO 9906 – Annex A

PERFORMANCE CURVE

50Hz

Rev. 0

ENR 32-250 MEI > 0.40

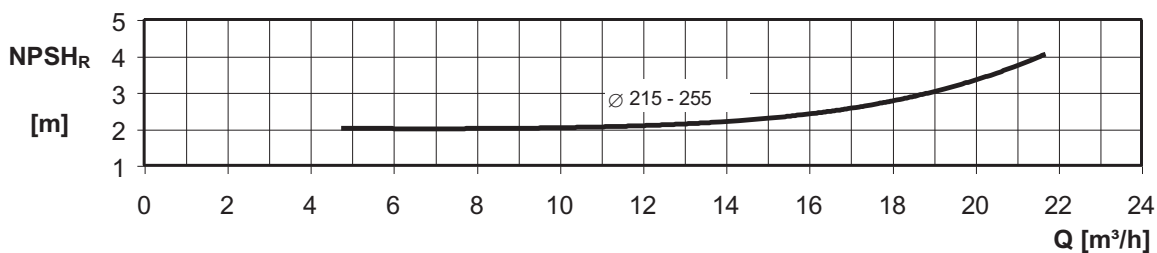
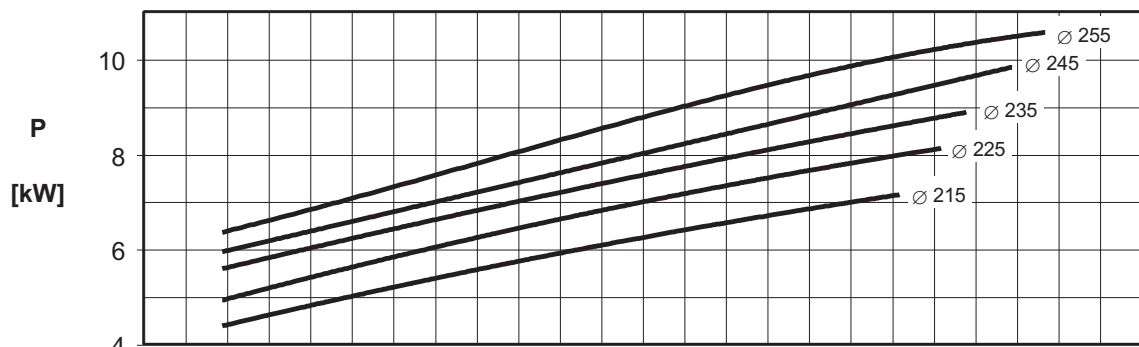
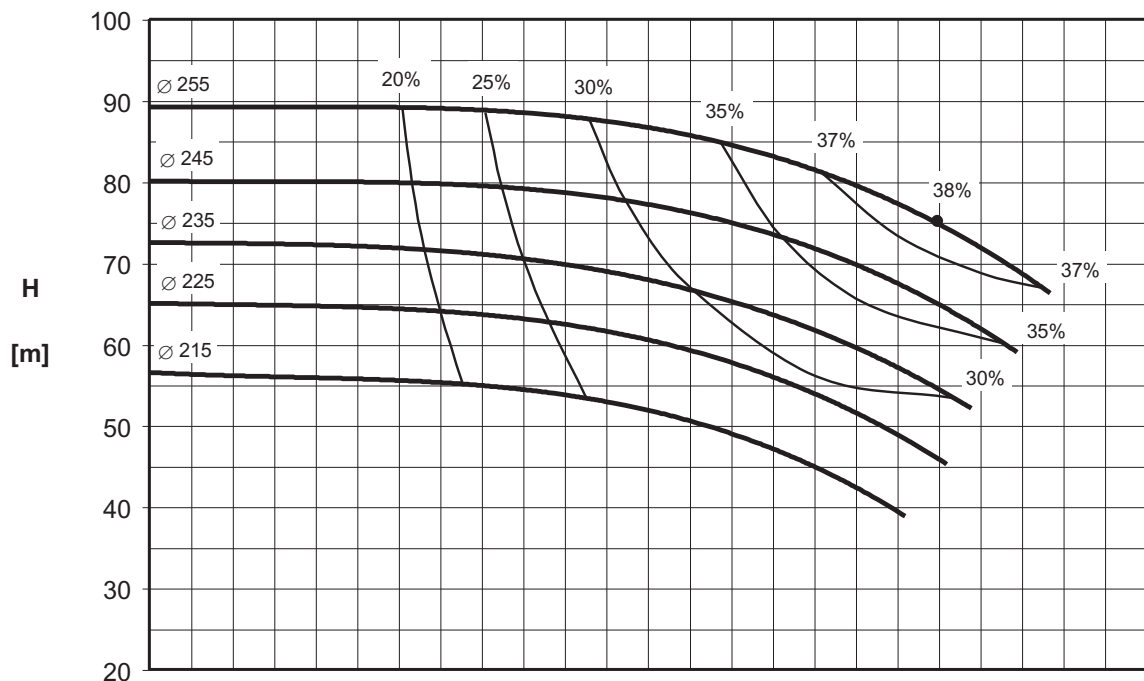

Rotation speed $\approx 2900 \text{ min}^{-1}$
Test standard: ISO 9906 – Annex A

ENR 40-125 MEI > 0.40

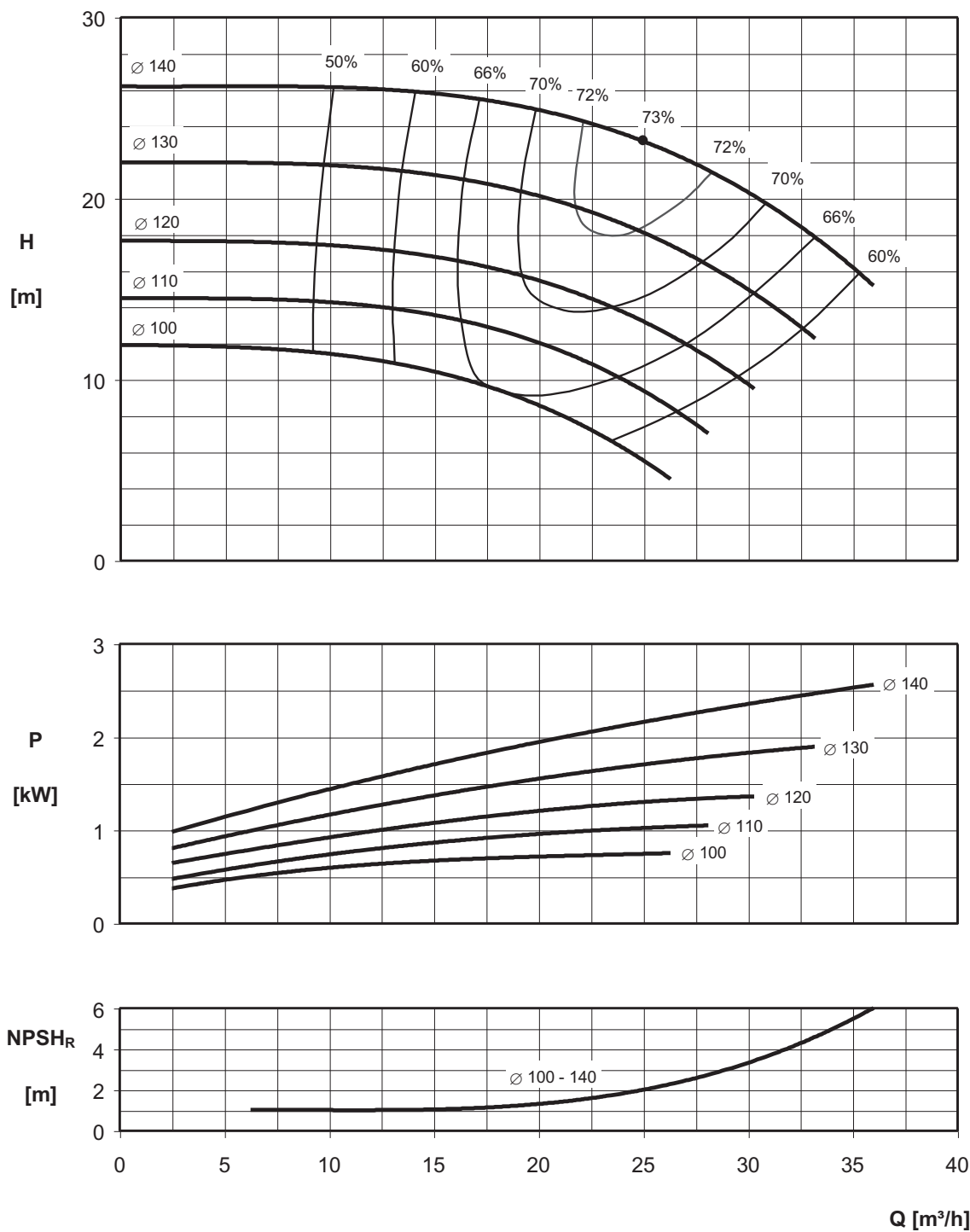

Rotation speed $\approx 2900 \text{ min}^{-1}$
Test standard: ISO 9906 – Annex A

ENR 40-160 MEI > 0.40

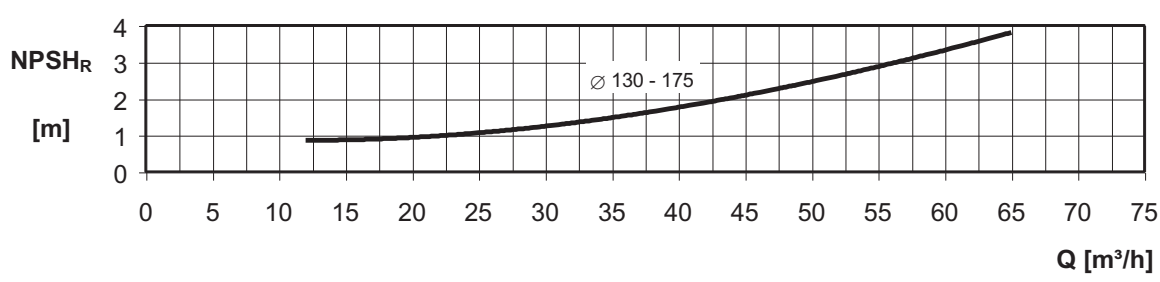
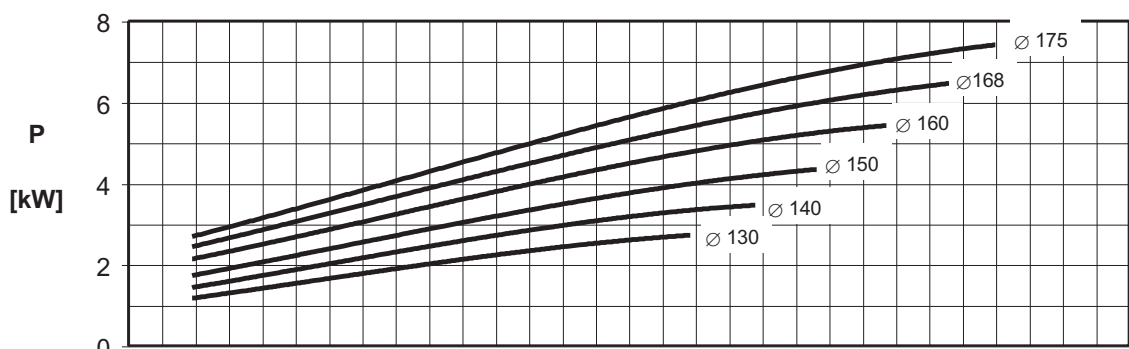
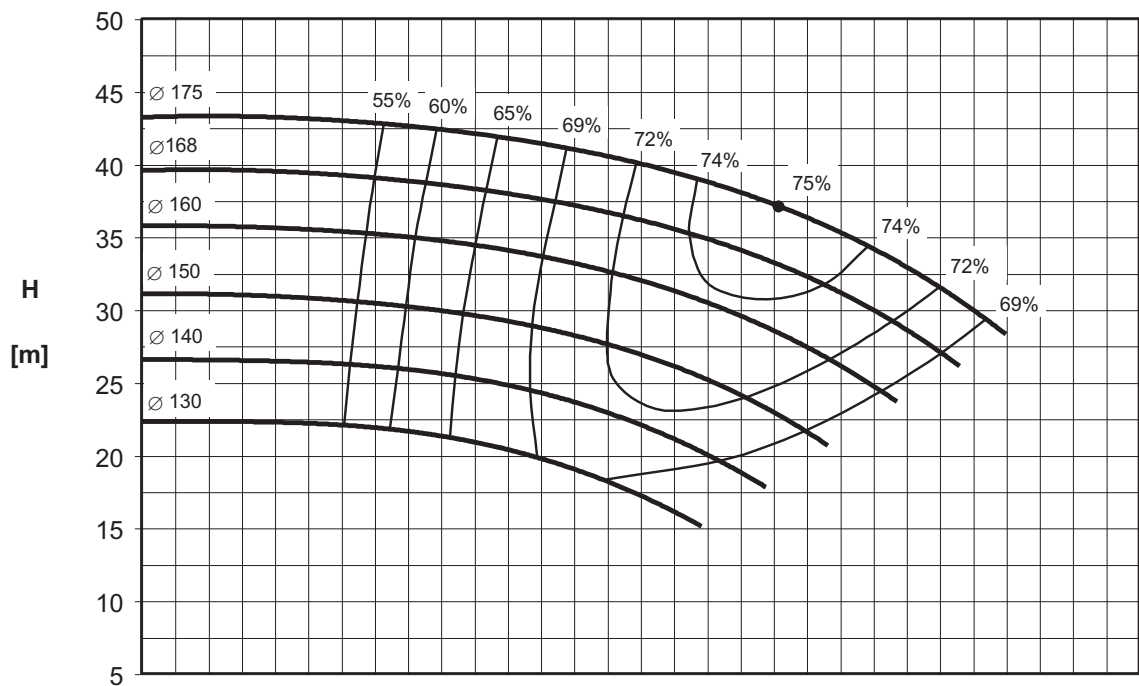

Rotation speed $\approx 2900 \text{ min}^{-1}$
Test standard: ISO 9906 – Annex A

ENR 40-200 MEI > 0.40

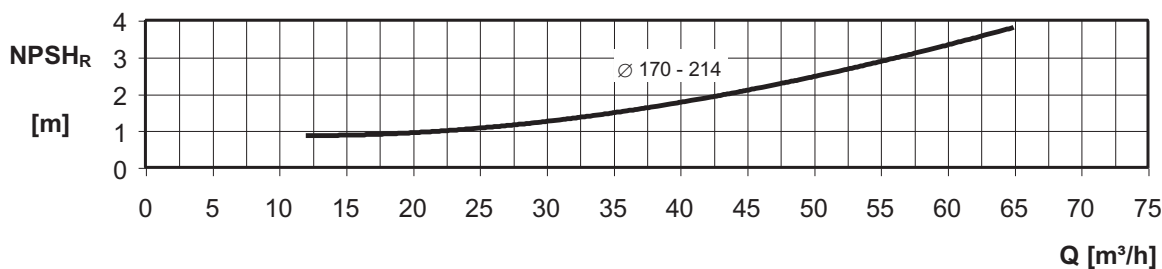
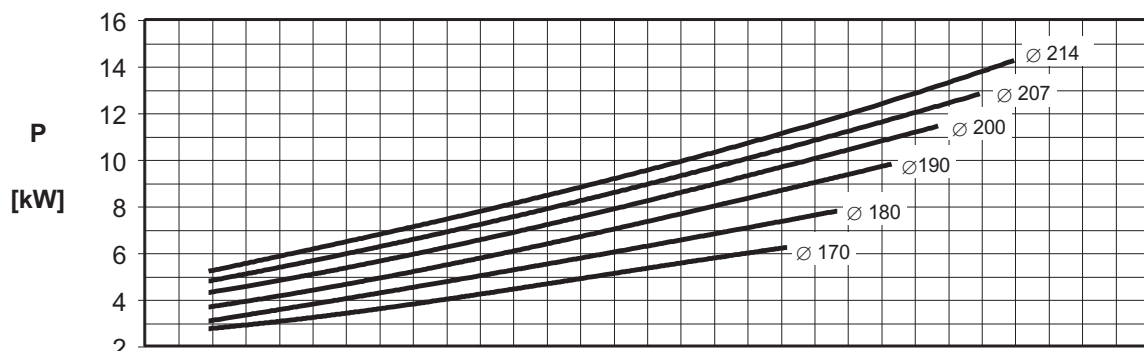
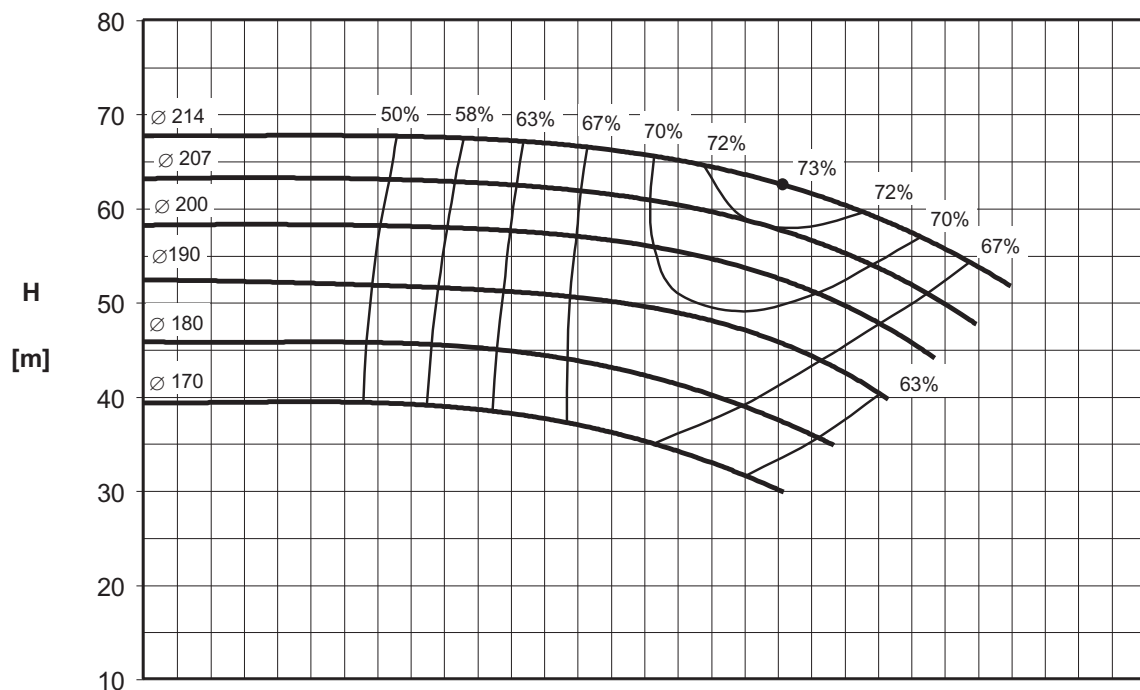

Rotation speed $\approx 2900 \text{ min}^{-1}$
Test standard: ISO 9906 – Annex A

PERFORMANCE CURVE

50Hz

Rev. 0

ENR 40-250 MEI > 0.40

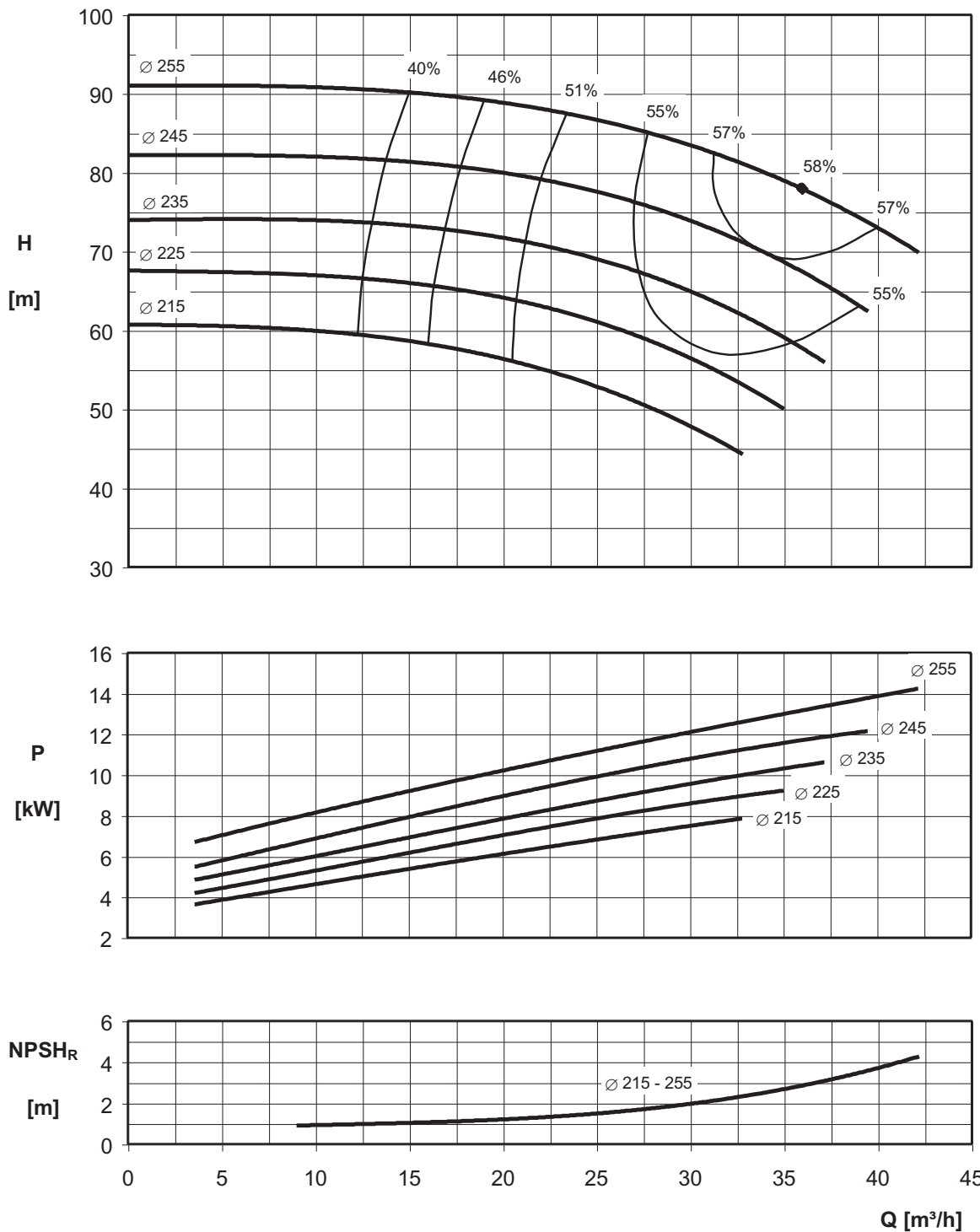

Rotation speed $\approx 2900 \text{ min}^{-1}$
 Test standard: ISO 9906 – Annex A

ENR 40-315 MEI > 0.40

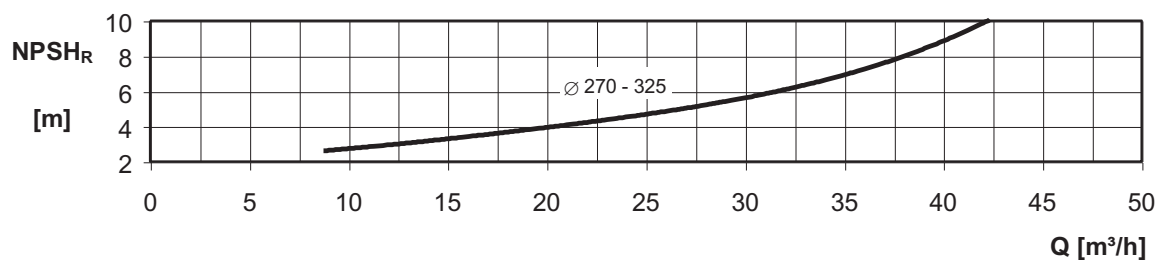
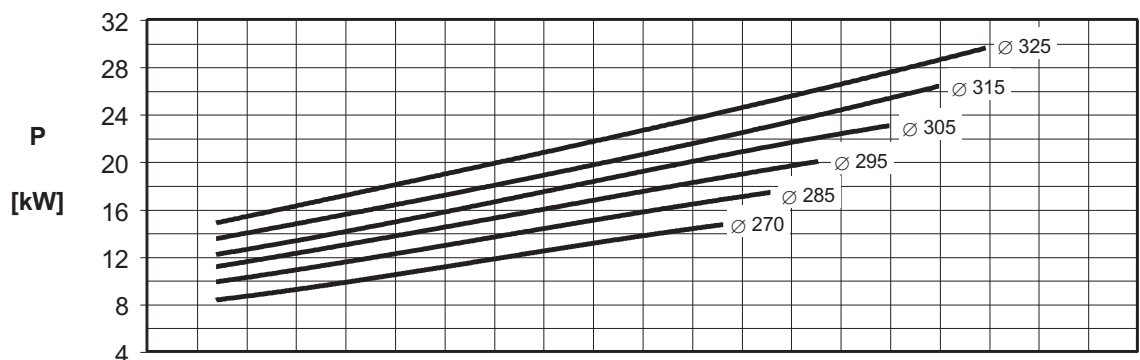
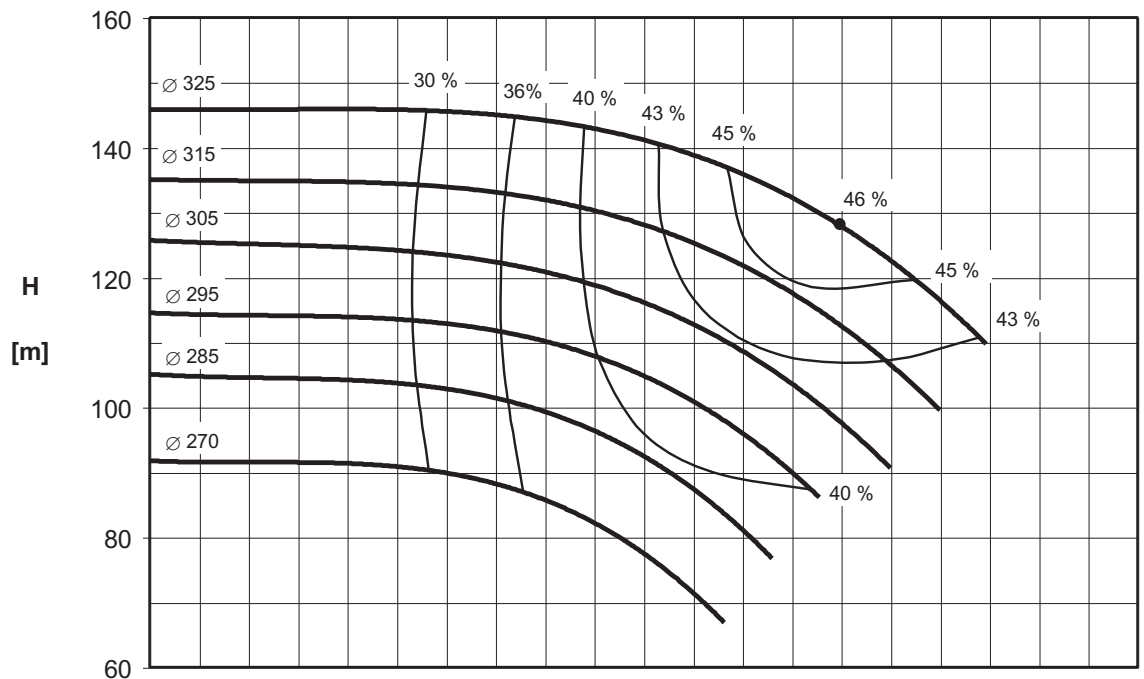

Rotation speed $\approx 2900 \text{ min}^{-1}$
Test standard: ISO 9906 – Annex A

PERFORMANCE CURVE

50Hz

Rev. 0

ENR 50-125 MEI > 0.40

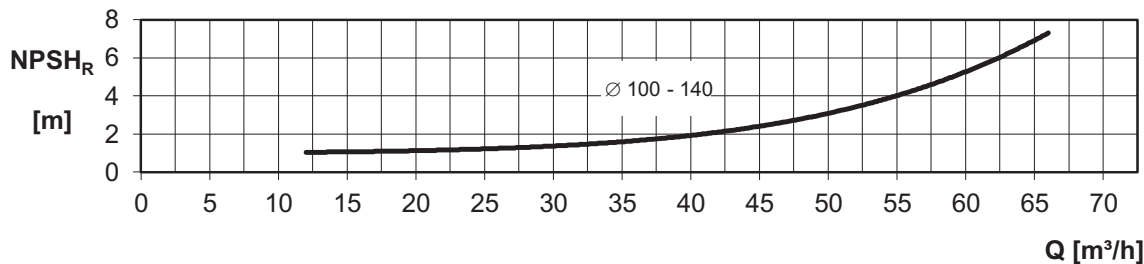
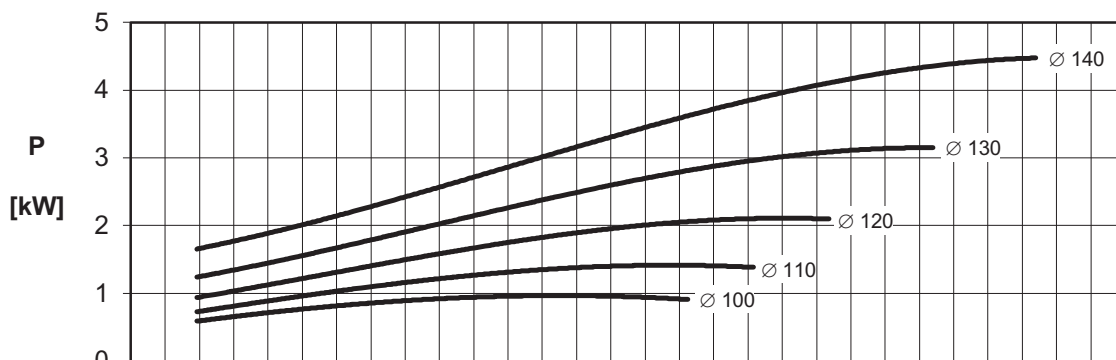
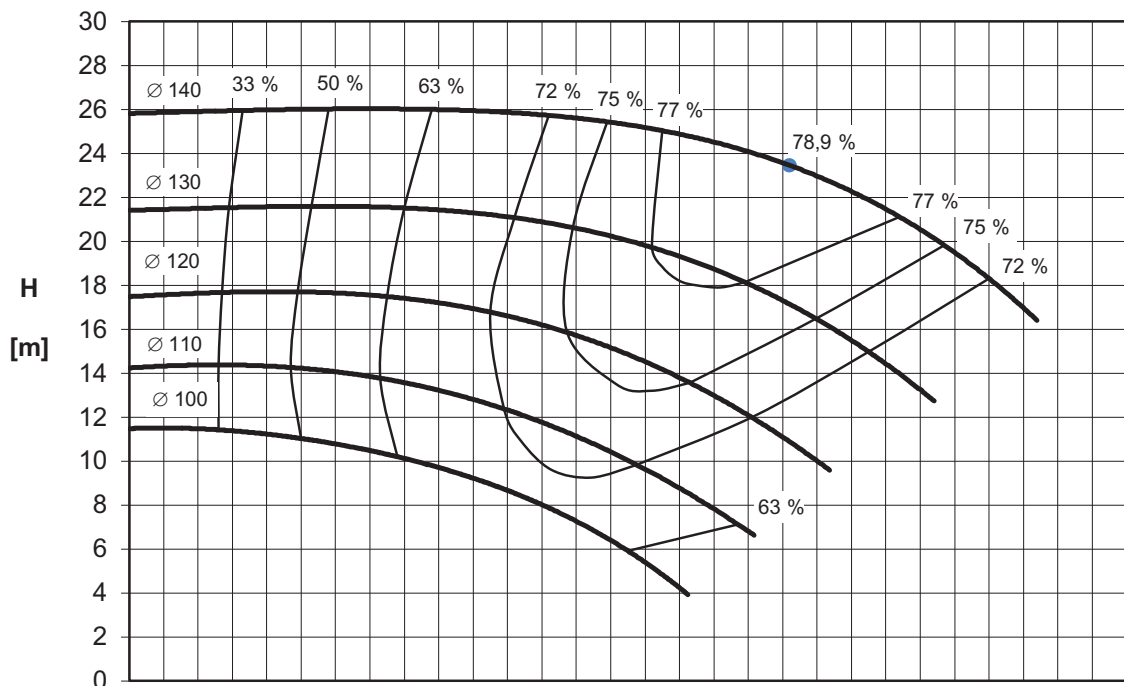

Rotation speed $\approx 2900 \text{ min}^{-1}$
Test standard: ISO 9906 – Annex A

ENR 50-160 MEI > 0.40

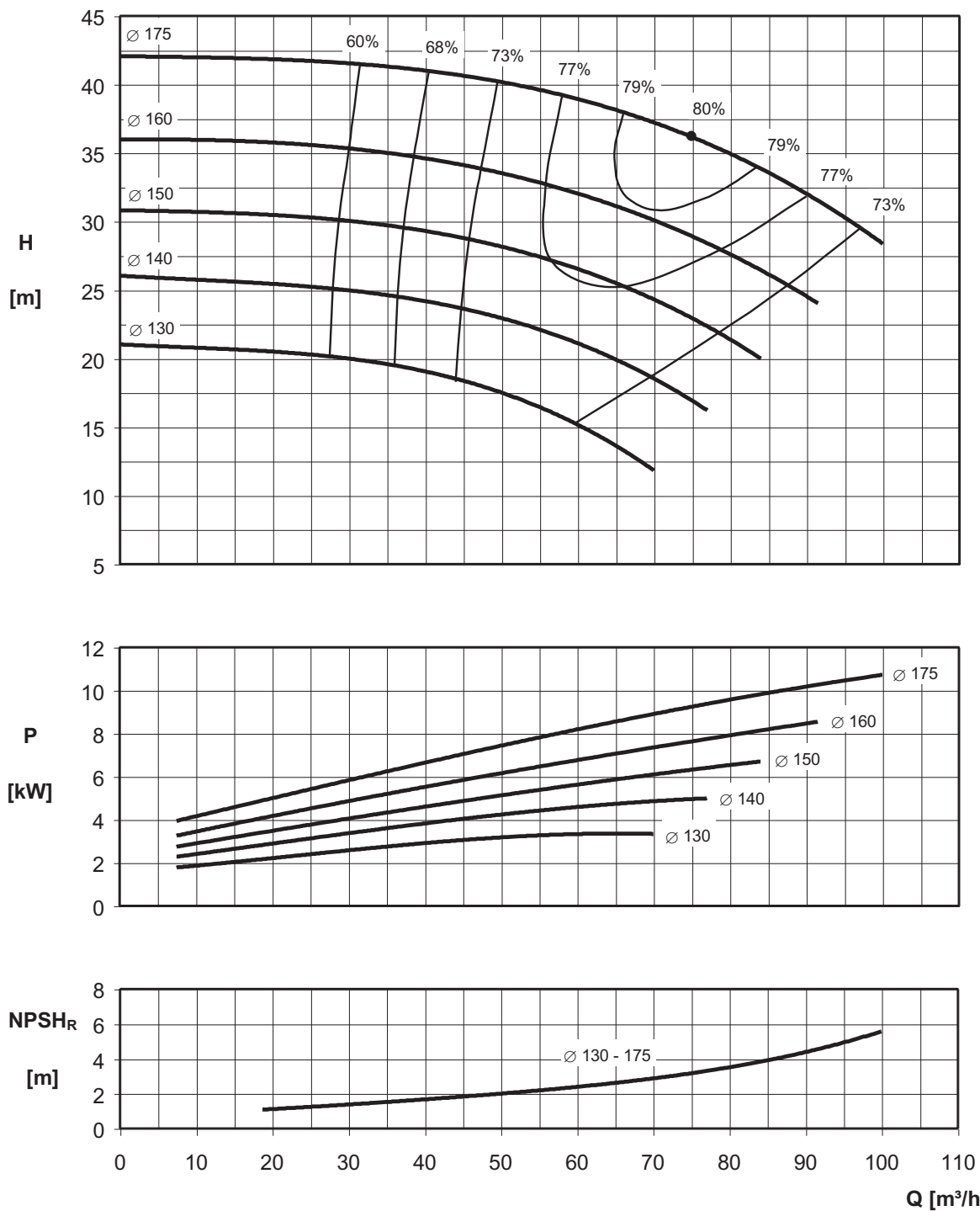

Rotation speed $\approx 2900 \text{ min}^{-1}$
Test standard: ISO 9906 – Annex A

PERFORMANCE CURVE

50Hz

Rev. 0

ENR 50-200 MEI > 0.40

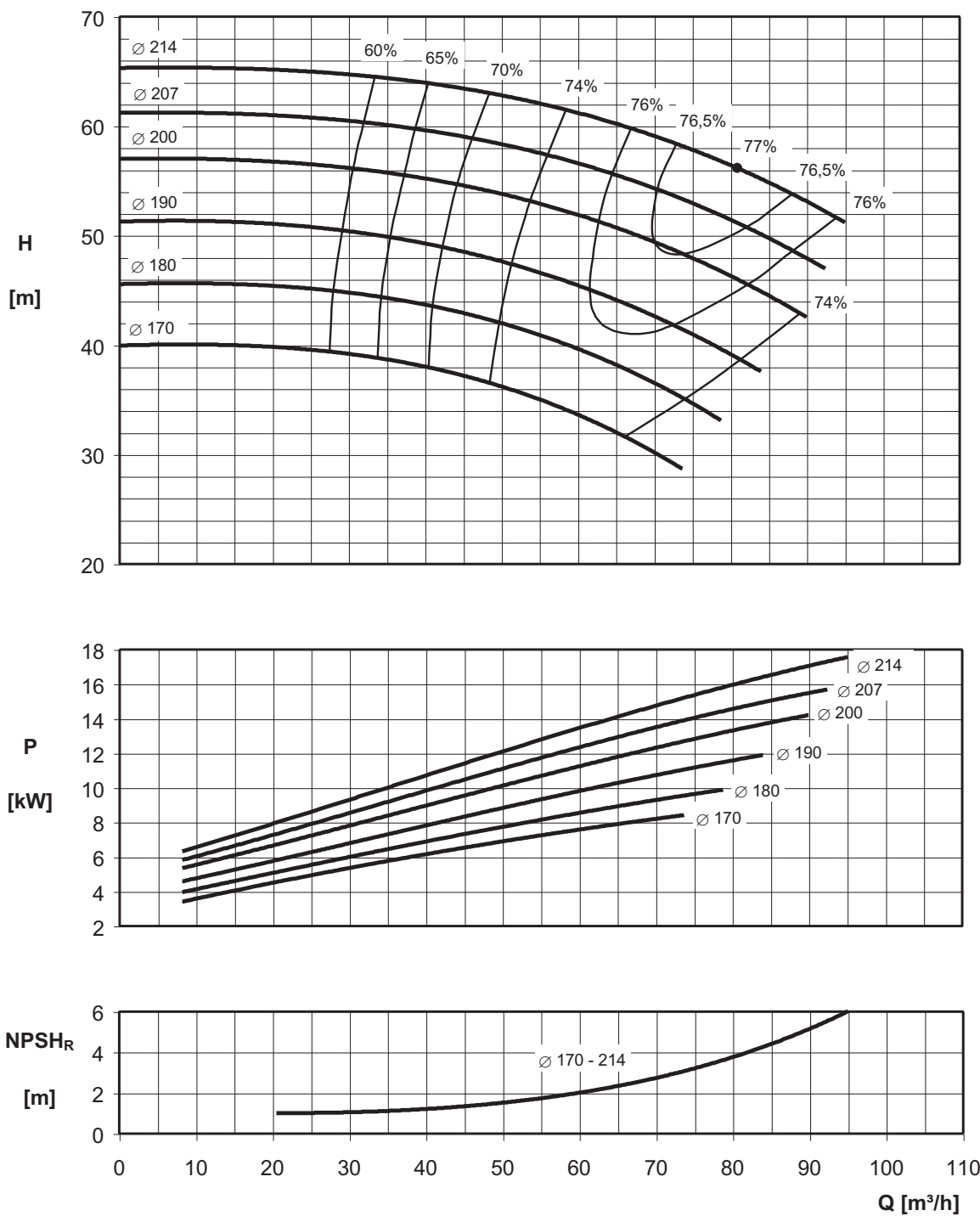

Rotation speed $\approx 2900 \text{ min}^{-1}$
Test standard: ISO 9906 – Annex A

ENR 50-250 MEI > 0.40

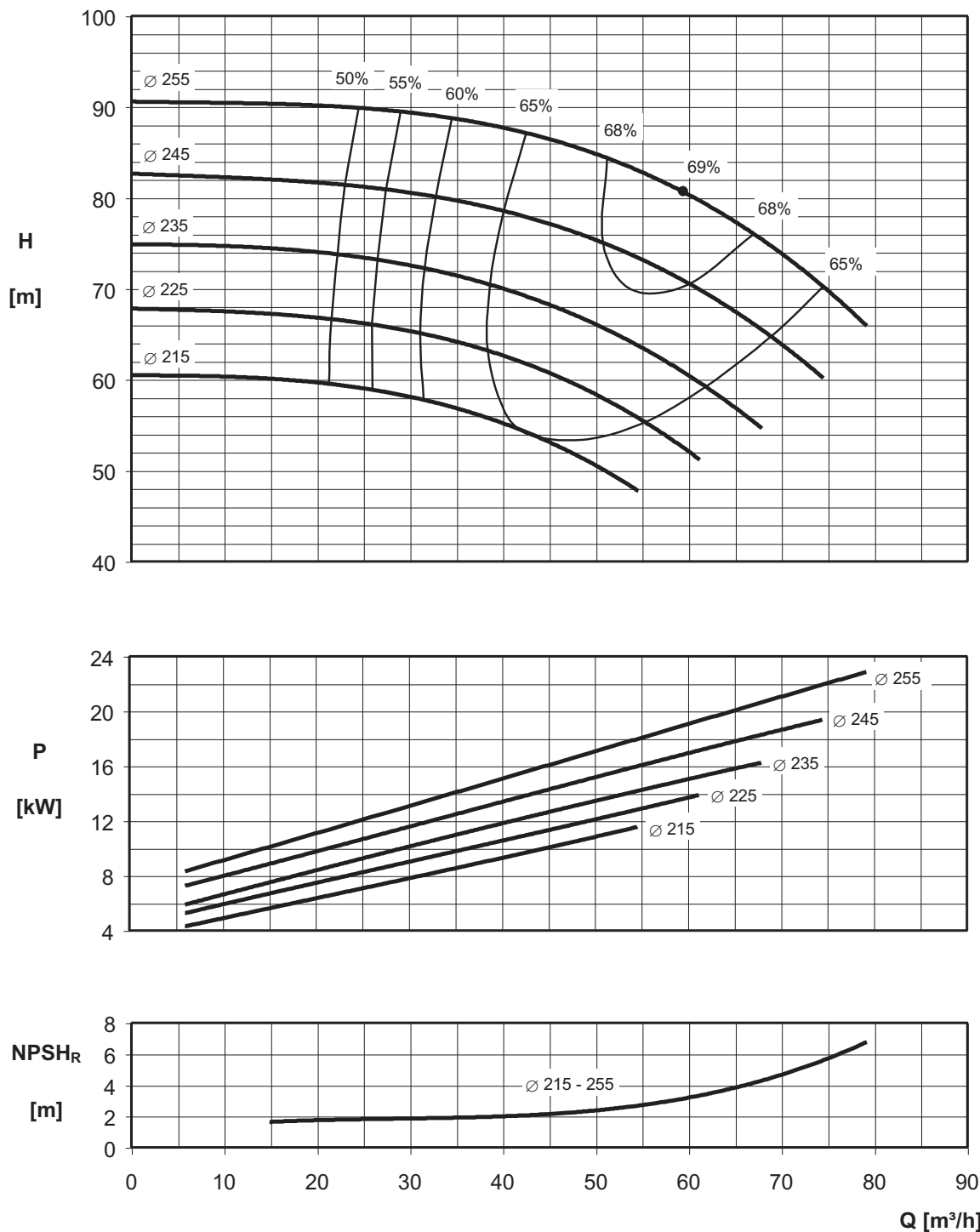

Rotation speed $\approx 2900 \text{ min}^{-1}$
Test standard: ISO 9906 – Annex A

ENR 50-315 MEI > 0.40

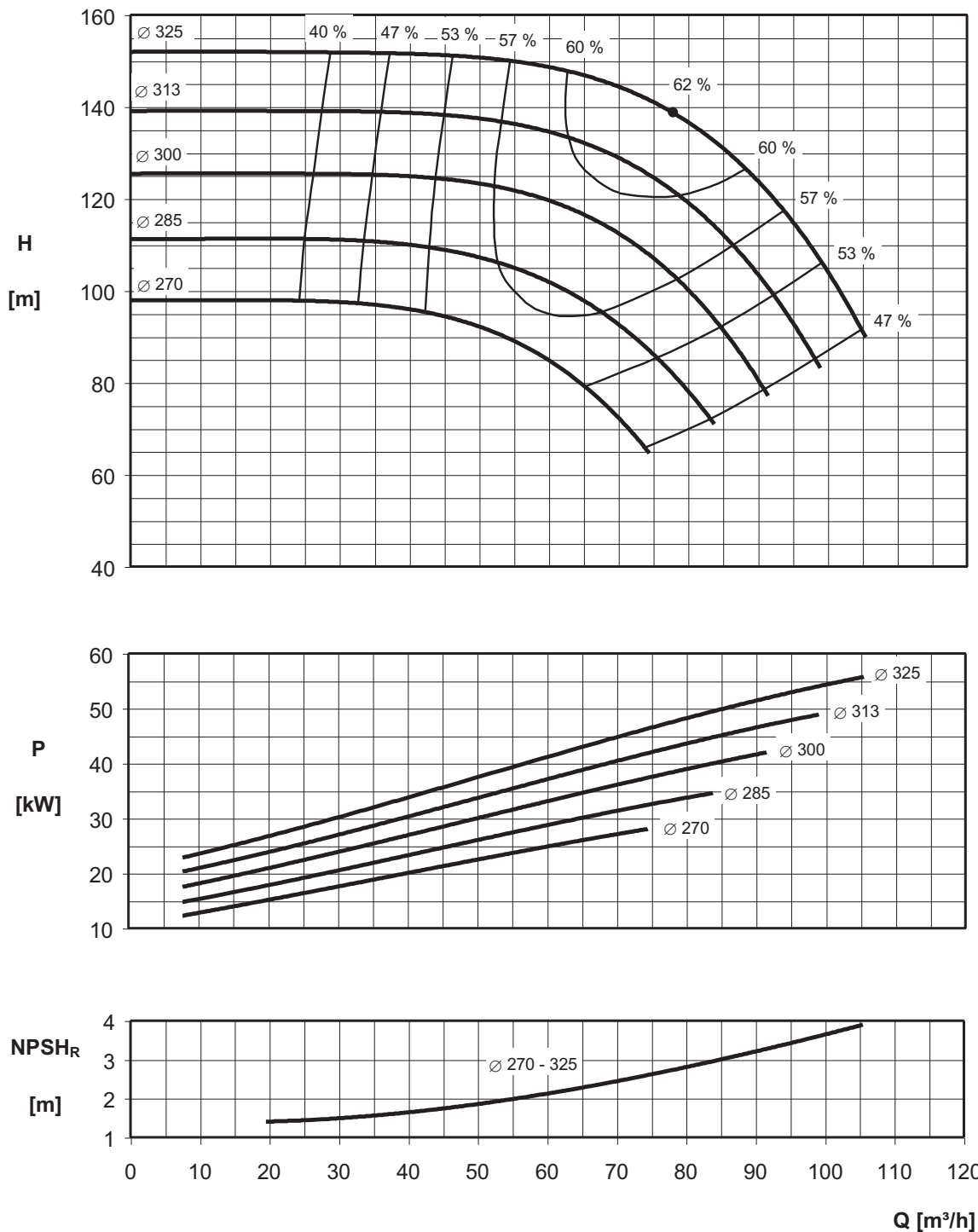

Rotation speed $\approx 2900 \text{ min}^{-1}$
Test standard: ISO 9906 – Annex A

ENR 65-125 MEI > 0.40

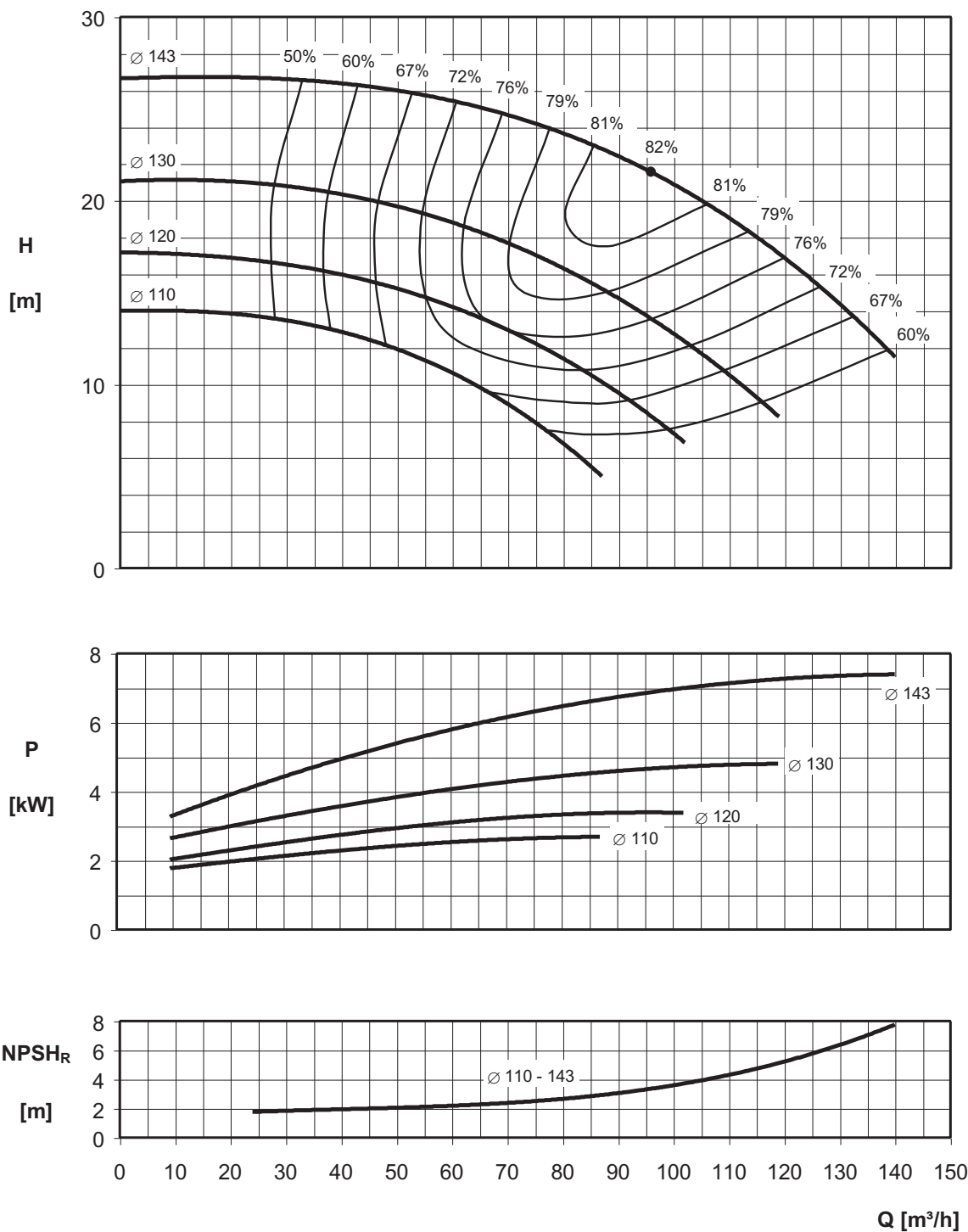

Rotation speed $\approx 2900 \text{ min}^{-1}$
Test standard: ISO 9906 – Annex A

PERFORMANCE CURVE

50Hz

Rev. 0

ENR 65-160 MEI > 0.40

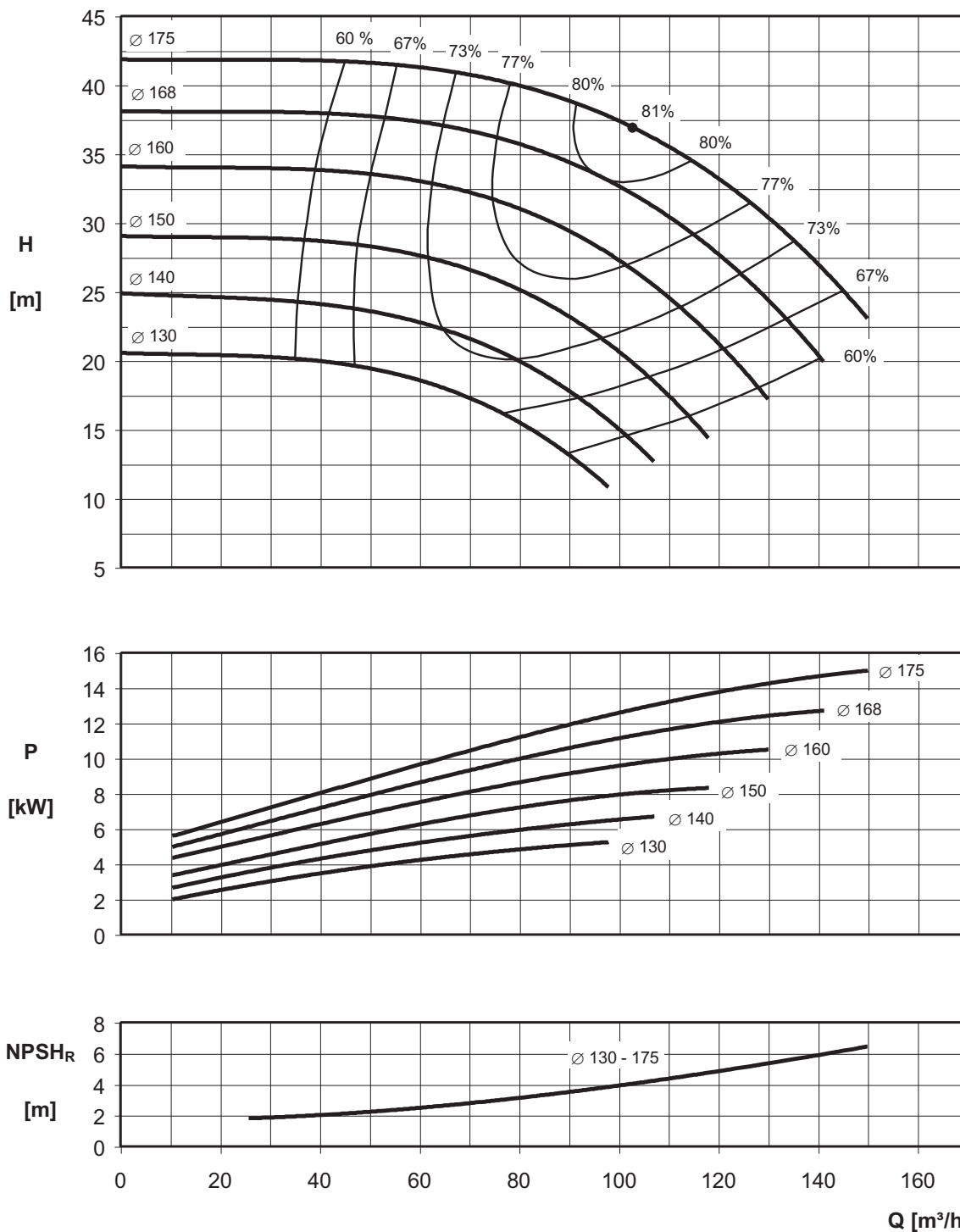

Rotation speed $\approx 2900 \text{ min}^{-1}$
Test standard: ISO 9906 – Annex A

ENR 65-200 MEI > 0.40

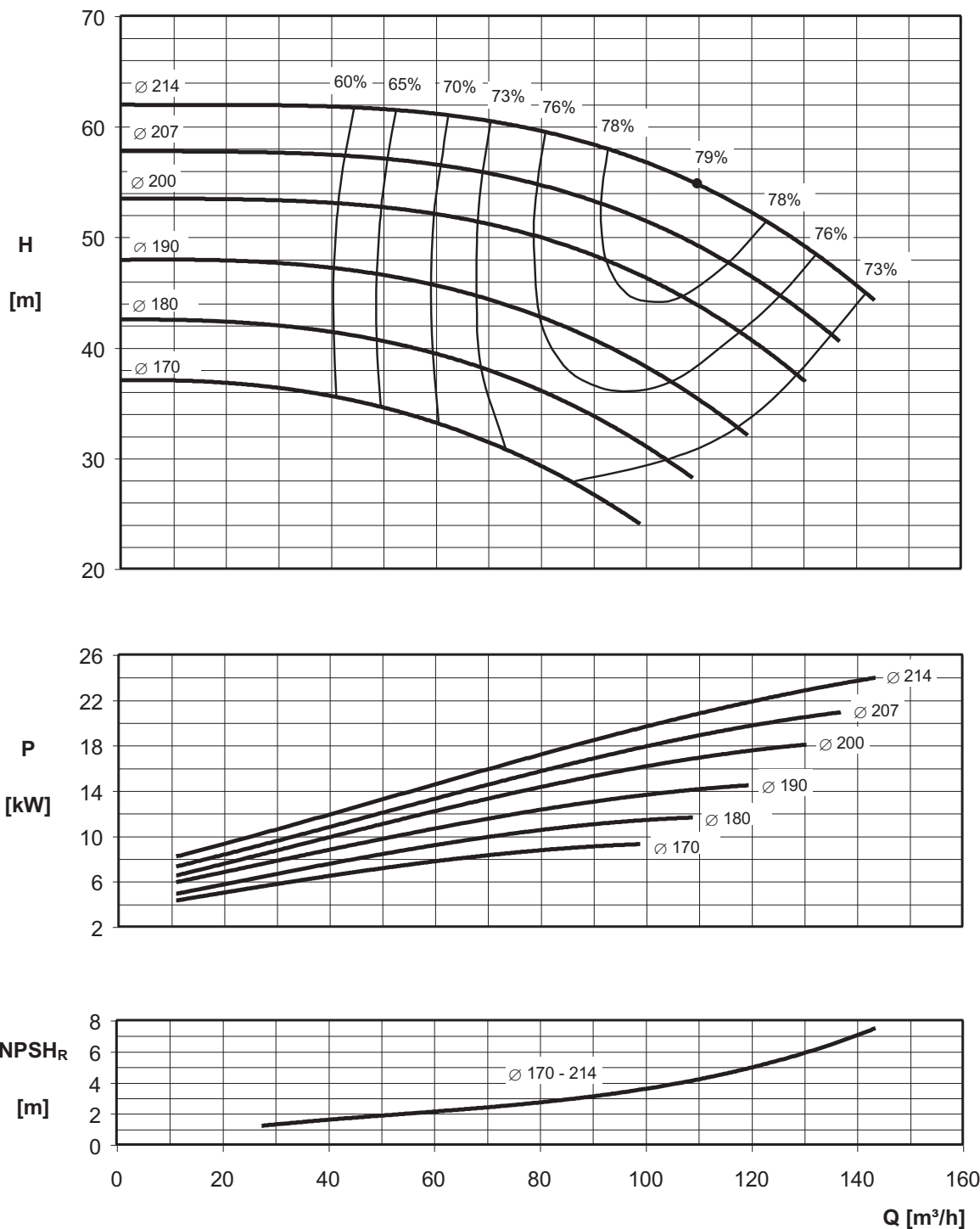

Rotation speed $\approx 2900 \text{ min}^{-1}$
Test standard: ISO 9906 – Annex A

PERFORMANCE CURVE

50Hz

Rev. 0

ENR 65-250 MEI > 0.40

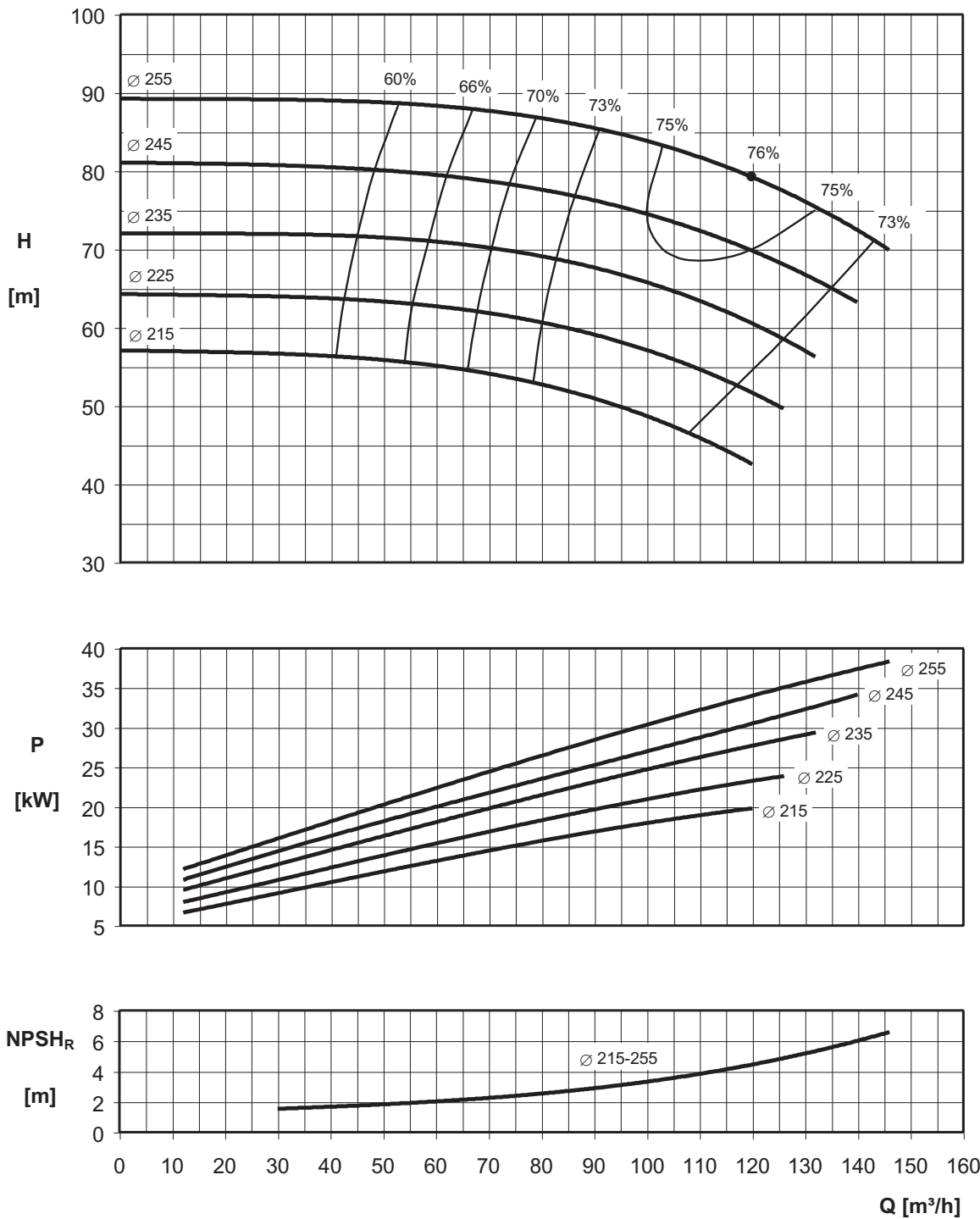

Rotation speed $\approx 2900 \text{ min}^{-1}$
Test standard: ISO 9906 – Annex A

232

ENR 80-160 MEI > 0.40

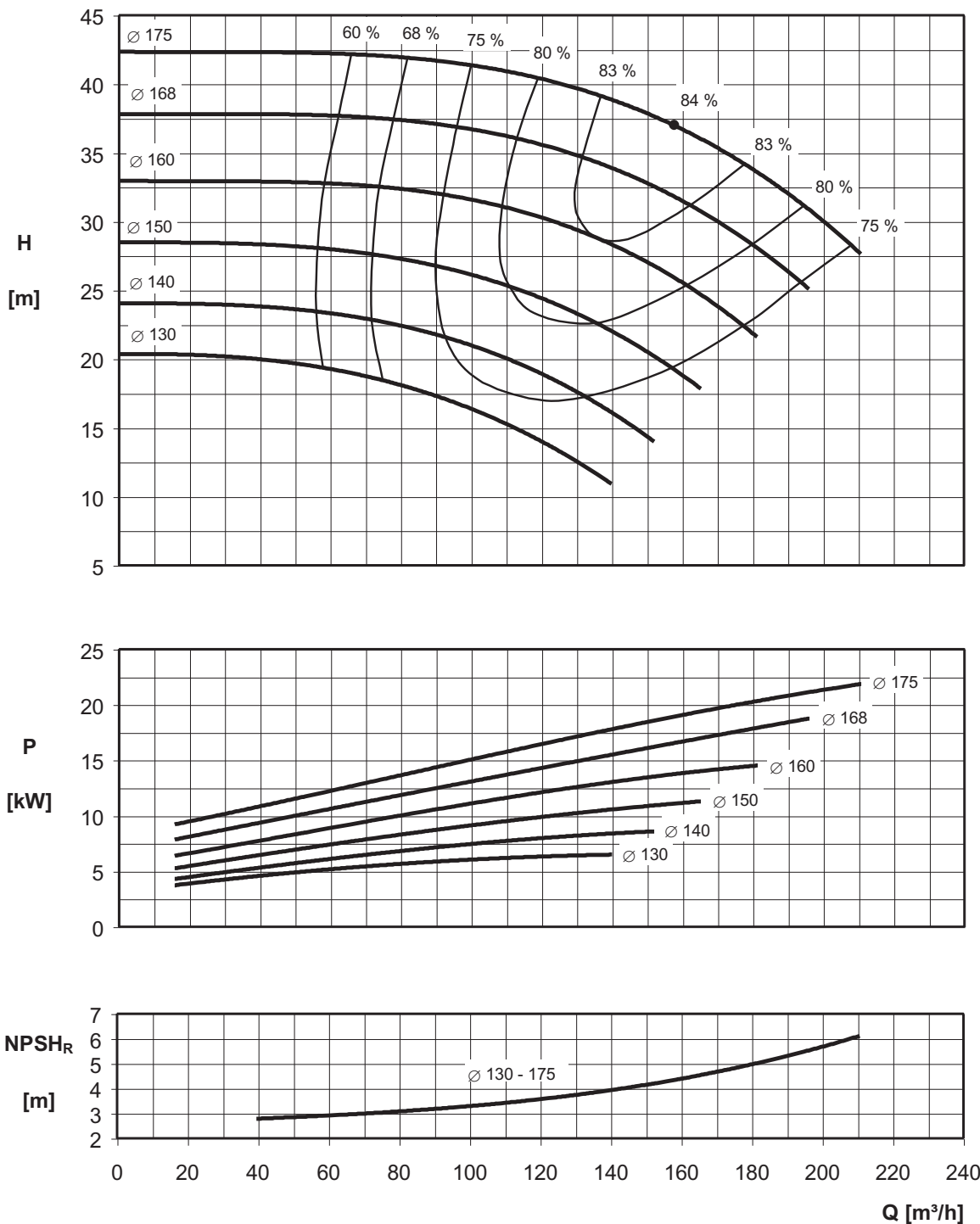

Rotation speed $\approx 2900 \text{ min}^{-1}$
Test standard: ISO 9906 – Annex A

ENR 80-200 MEI > 0.40

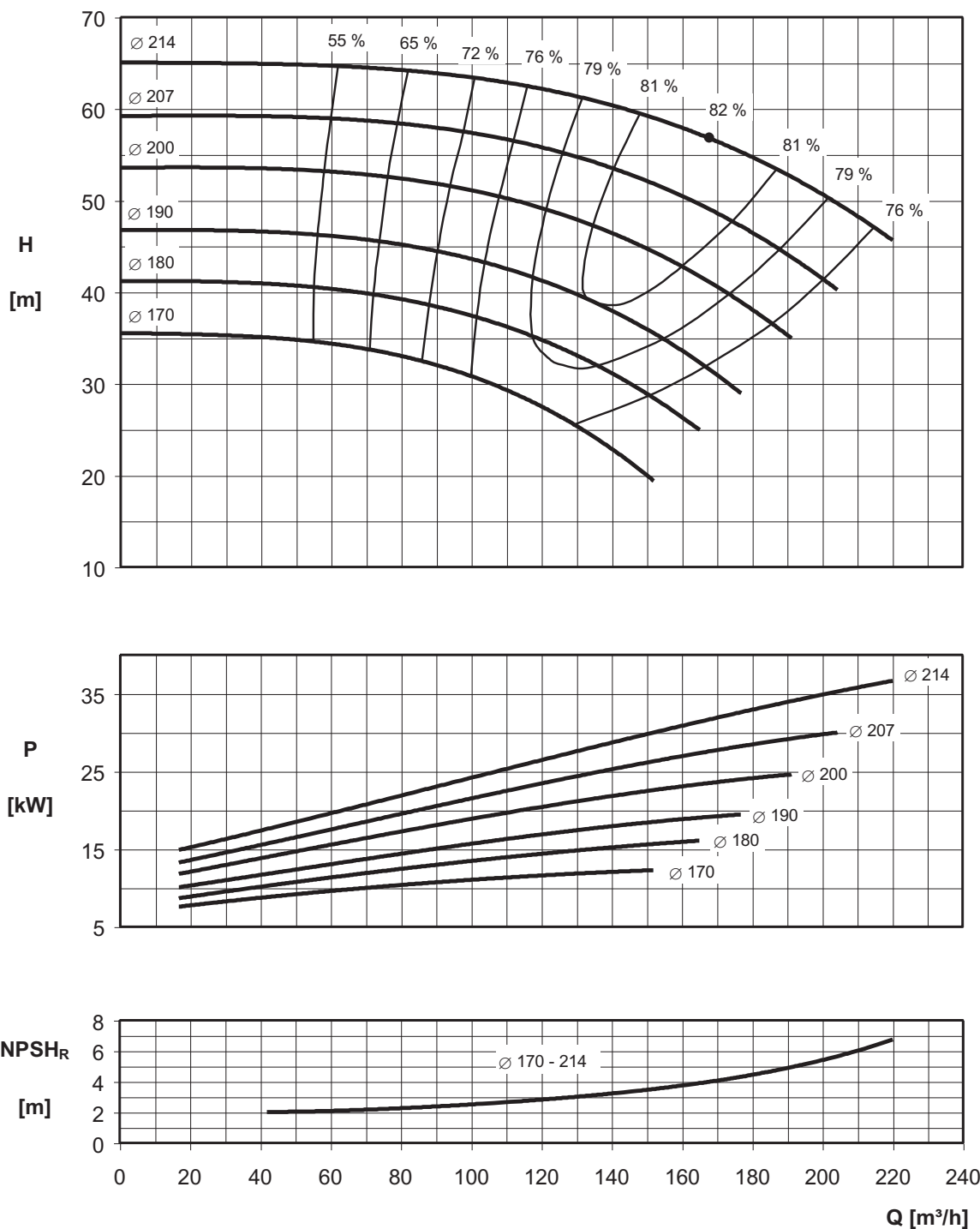

Rotation speed $\approx 2900 \text{ min}^{-1}$
Test standard: ISO 9906 – Annex A

ENR 80-250 MEI > 0.40

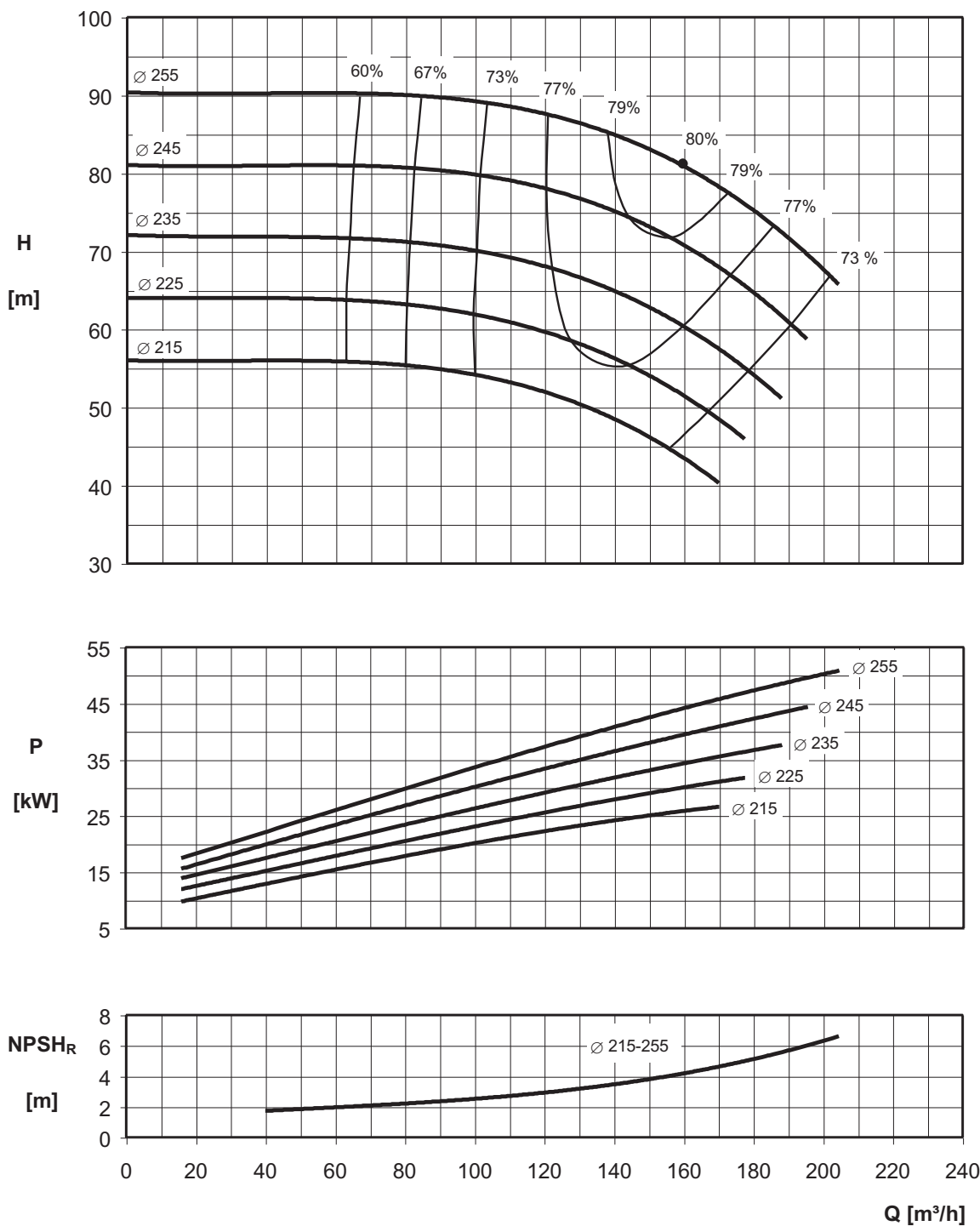

Rotation speed $\approx 2900 \text{ min}^{-1}$
Test standard: ISO 9906 – Annex A

ENR 100-160 MEI > 0.40

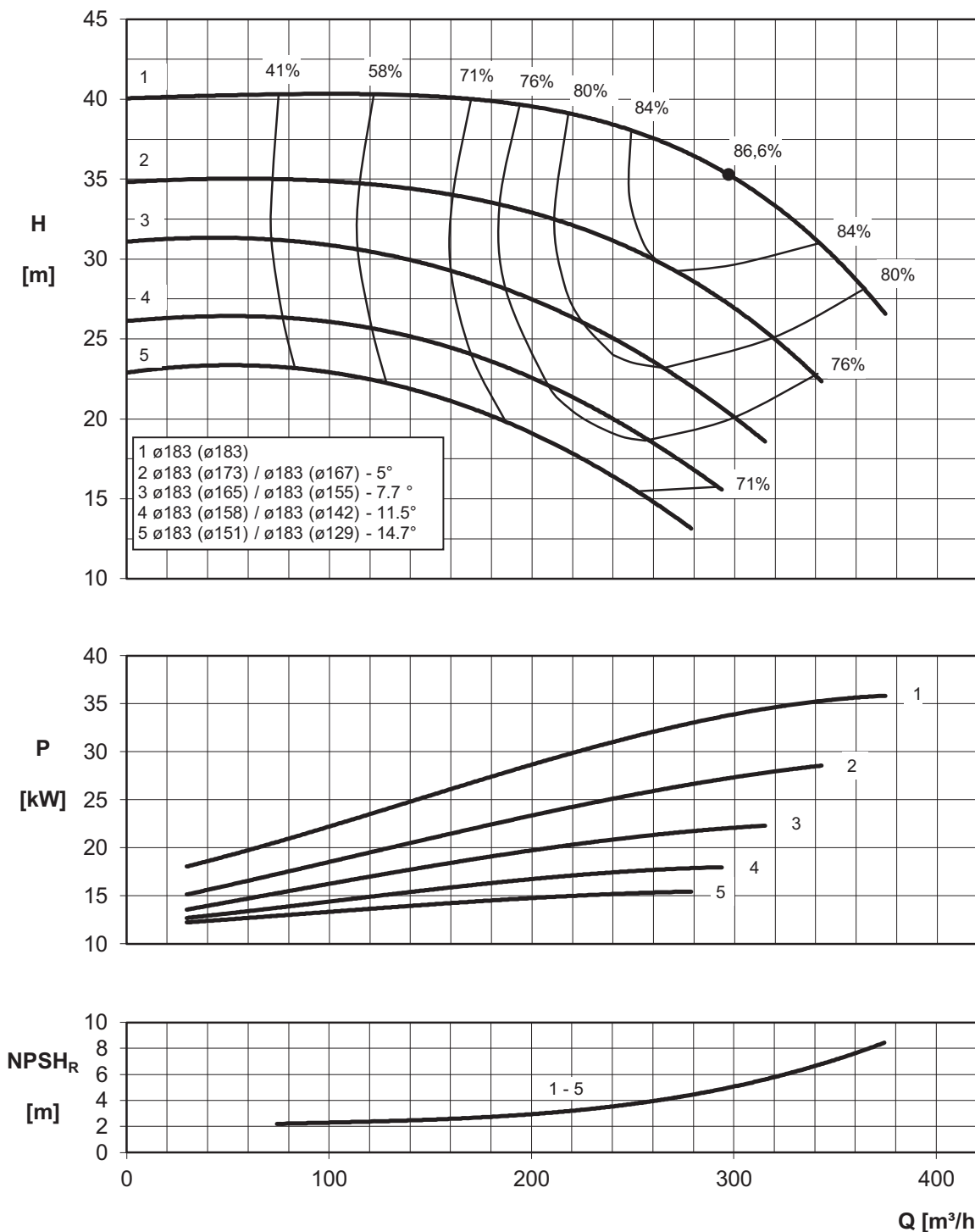

Rotation speed $\approx 2900 \text{ min}^{-1}$
 Test standard: ISO 9906 – Annex A

ENR 100-200 MEI > 0.40

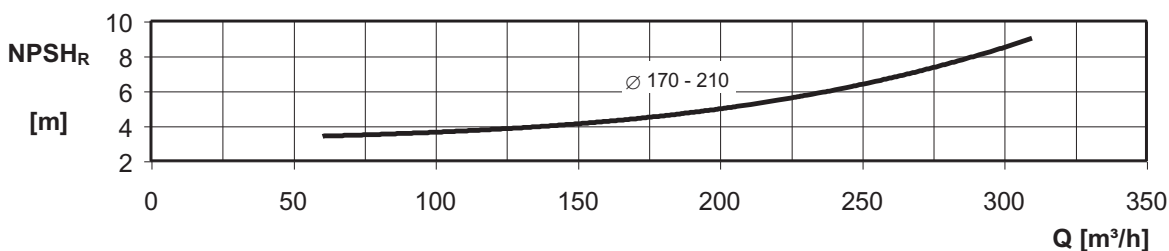
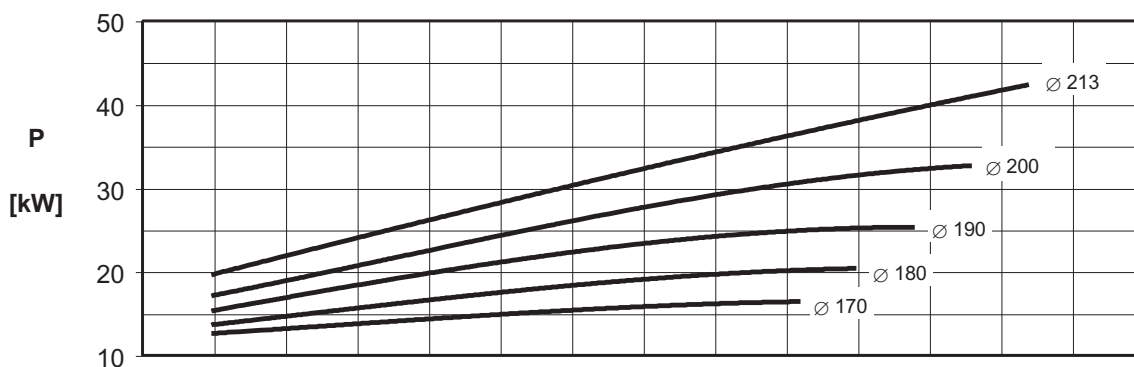
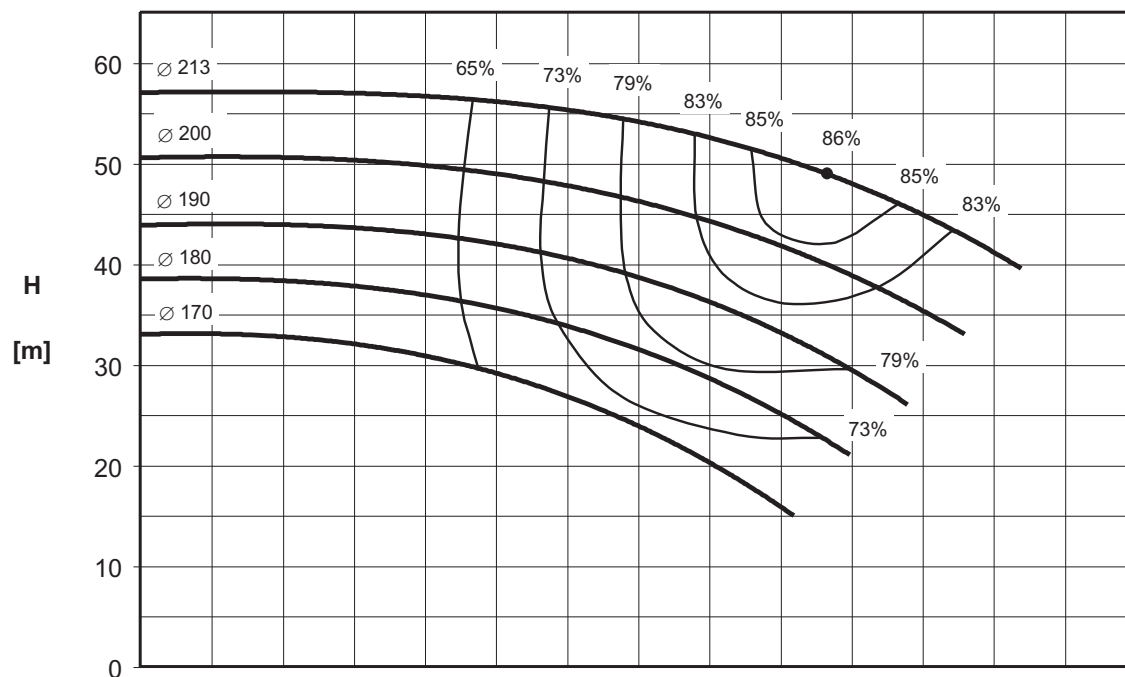

Rotation speed $\approx 2900 \text{ min}^{-1}$
Test standard: ISO 9906 – Annex A

PERFORMANCE CURVE

50Hz

Rev. 0

ENR 100-250 MEI > 0.40

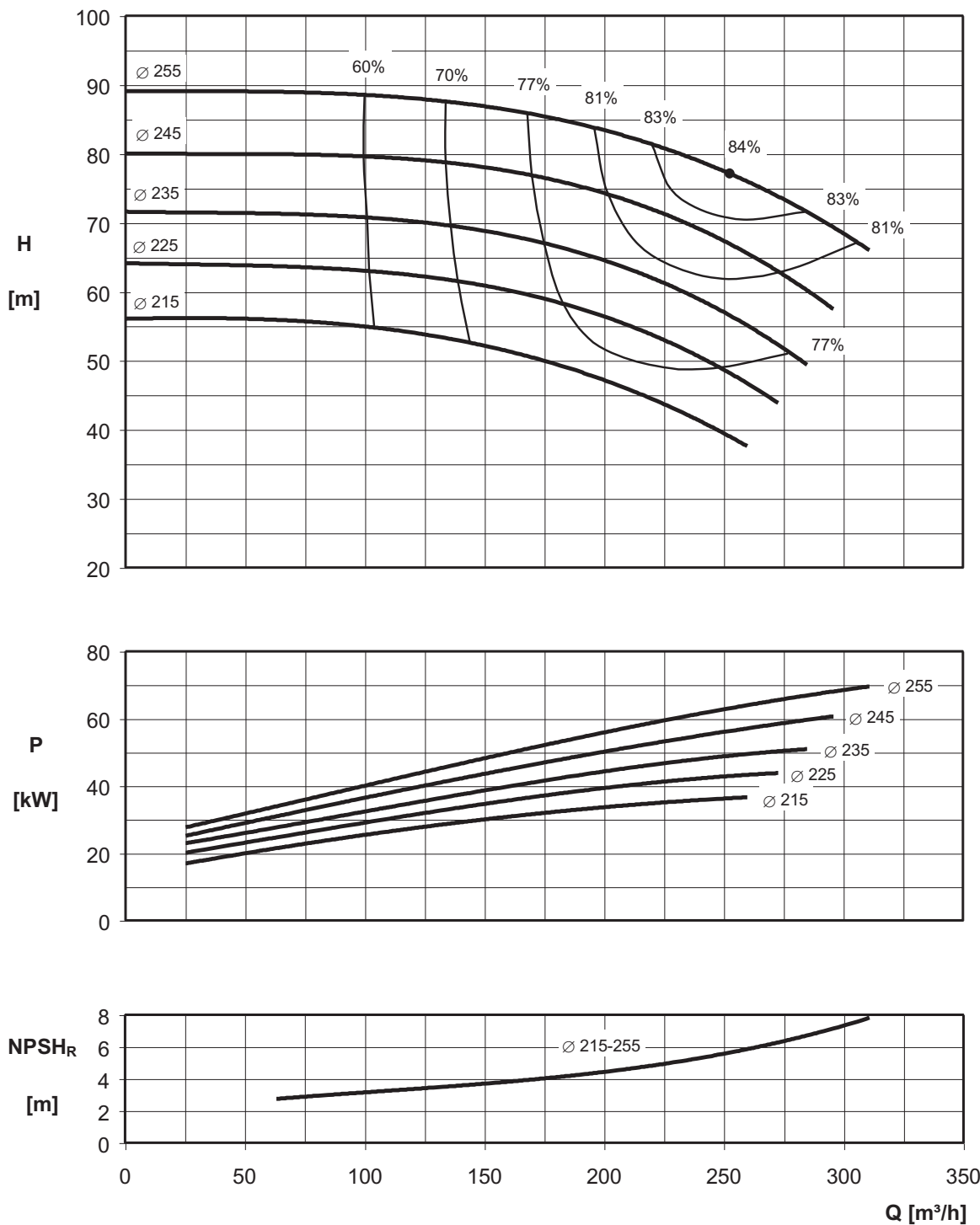

Rotation speed $\approx 2900 \text{ min}^{-1}$
Test standard: ISO 9906 – Annex A

PERFORMANCE CURVE

50Hz

Rev. 0

ENR 125-200 MEI > 0.40

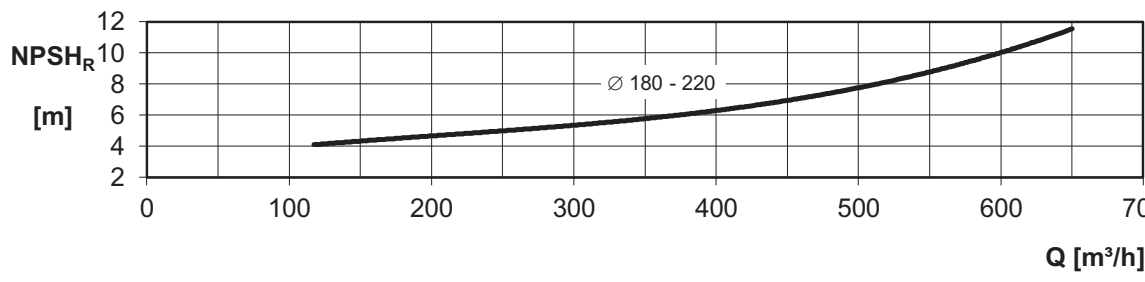
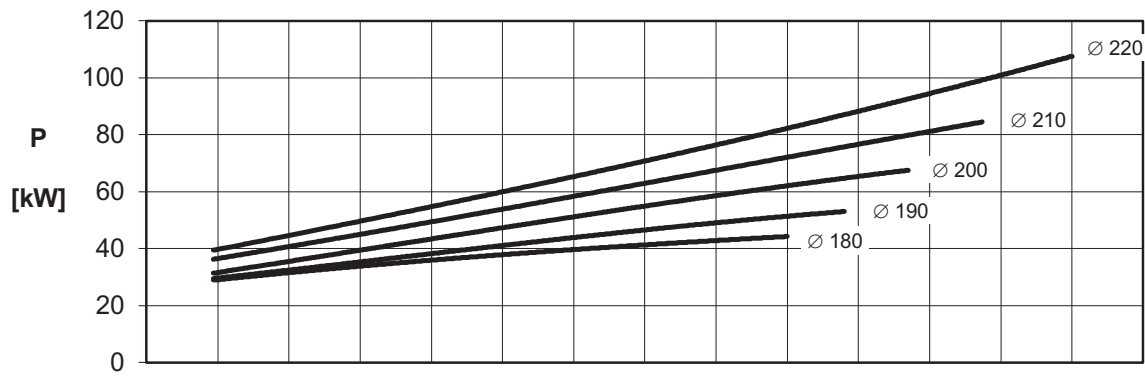
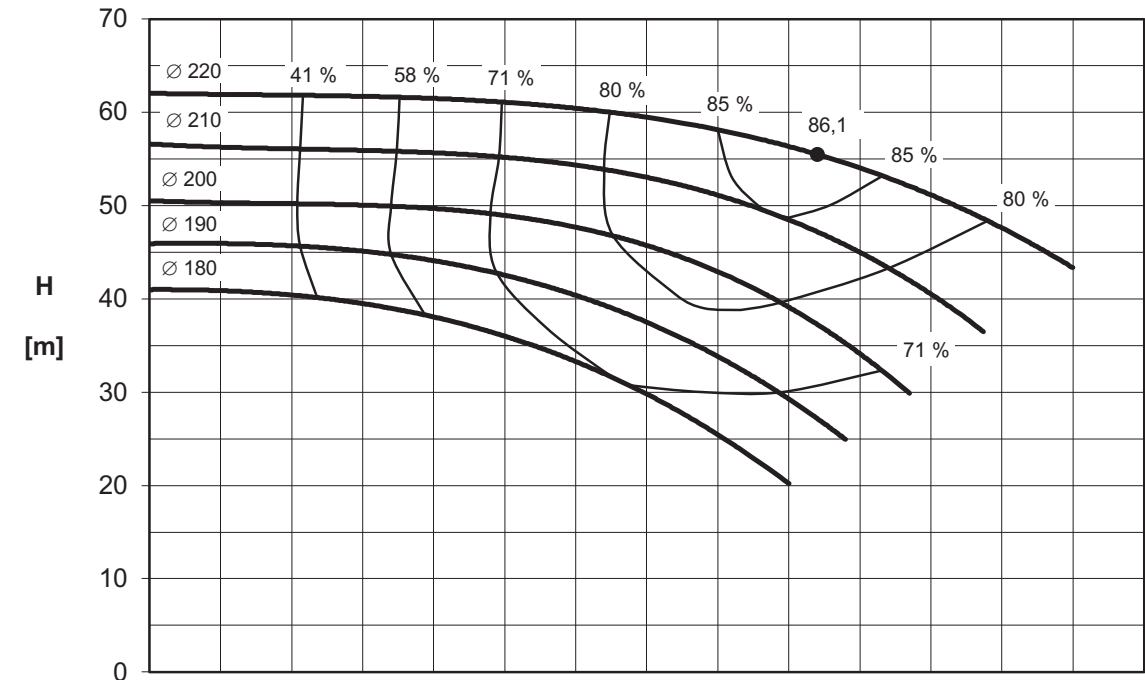

Rotation speed $\approx 2900 \text{ min}^{-1}$
Test standard: ISO 9906 – Annex A

SECTIONAL VIEW

25 – 35 - 45

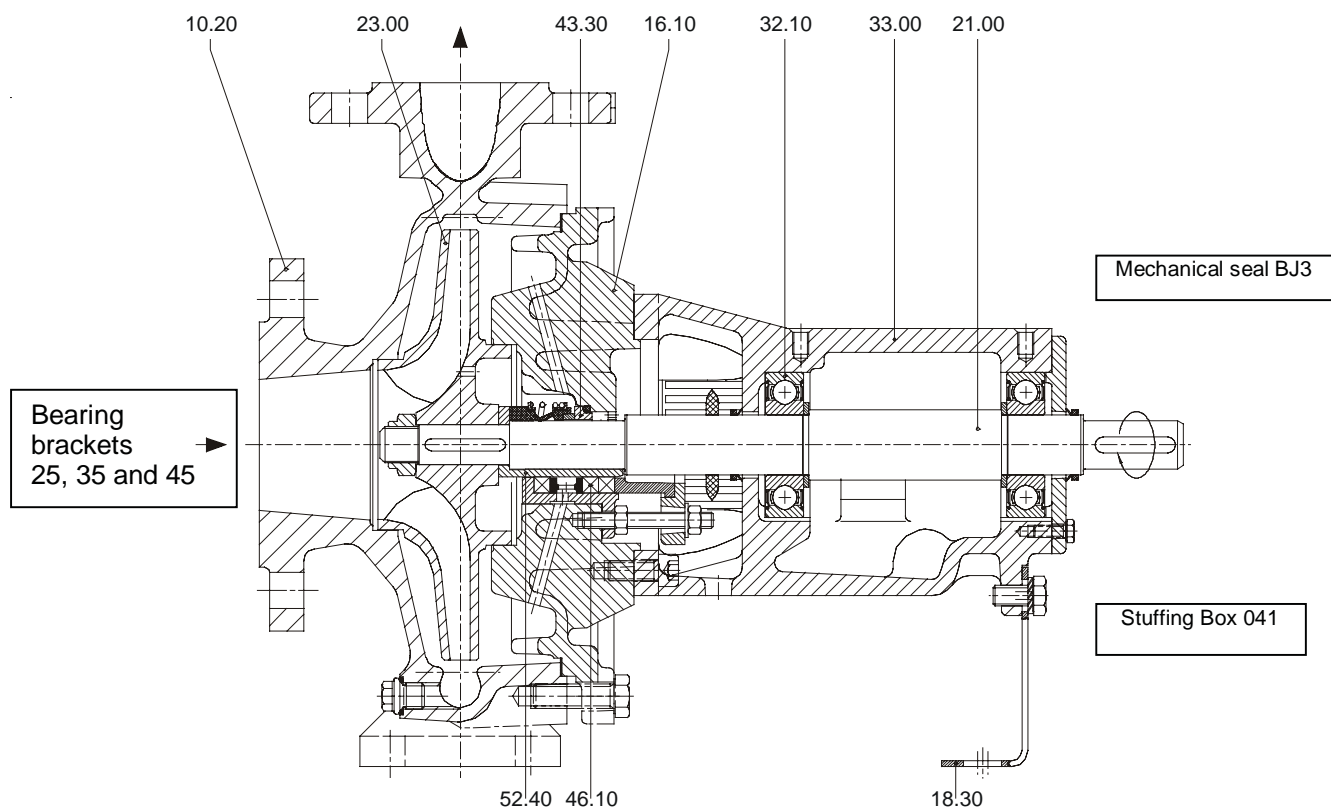

N°	PART NAME
10.20	volute casing
16.10	casing cover
18.30	support foot
21.00	shaft
23.00	impeller
32.10	ball bearing
33.00	bearing bracket
43.30	mechanical seal
46.10	stuffing box
52.40	shaft sleeve (stuffing box)

DIMENSIONS AND WEIGHT

50Hz

Rev. 0

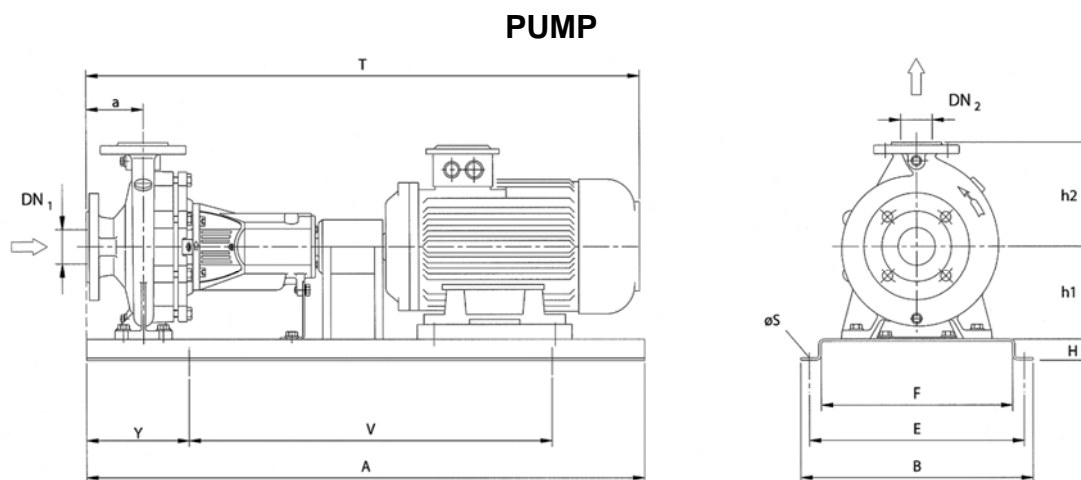

Dimension table 32 - 40

Model	Motor		Dimensions [mm]														[kgf]
	[Kw]	MEC	DN2	DN1	a	h2	h1	Standard Coupling							T		
								A	B	F	Y	V	E	H	S		
ENR 32-125	0,75	80	32	50	80	140	112	900	390	300	150	600	350	50	18	714	70,0
ENR 32-125	1,1	80	32	50	80	140	112	900	390	300	150	600	350	50	18	714	70,0
ENR 32-125	1,5	90S	32	50	80	140	112	900	390	300	150	600	350	50	18	764	73,0
ENR 32-125	2,2	90L	32	50	80	140	112	900	390	300	150	600	350	50	18	764	76,0
ENR 32-160	1,5	90S	32	50	80	160	132	900	390	300	150	600	350	50	18	764	74,0
ENR 32-160	2,2	90L	32	50	80	160	132	900	390	300	150	600	350	50	18	764	77,0
ENR 32-160	3	100L	32	50	80	160	132	900	390	300	150	600	350	50	18	844	87,0
ENR 32-160	4	112	32	50	80	160	132	900	490	380	150	600	440	50	18	844	99,0
ENR 32-160	5,5	132S	32	50	80	160	132	900	490	380	150	600	440	50	18	926	110,0
ENR 32-200	2,2	90L	32	50	80	180	160	900	390	300	150	600	350	50	18	764	84,0
ENR 32-200	3	100L	32	50	80	180	160	900	390	300	150	600	350	50	18	844	91,0
ENR 32-200	4	112	32	50	80	180	160	900	490	380	150	600	440	50	18	844	103,0
ENR 32-200	5,5	132S	32	50	80	180	160	900	490	380	150	600	440	50	18	926	121,0
ENR 32-200	7,5	132S	32	50	80	180	160	900	490	380	150	600	440	50	18	926	121,0
ENR 32-200	11	160M	32	50	80	180	160	1120	490	380	190	740	440	50	22	1092	167,0
ENR 32-250	7,5	132S	32	50	100	225	180	900	490	380	150	600	440	50	18	946	132,0
ENR 32-250	11	160M	32	50	100	225	180	1120	610	480	190	740	550	50	22	1112	187,0
ENR 32-250	15	160M	32	50	100	225	180	1120	610	480	190	740	550	50	22	1112	187,0
ENR 32-250	18,5	160L	32	50	100	225	180	1120	610	480	190	740	550	50	22	1112	201,0
ENR 40-125	1,1	80	40	65	80	140	112	900	390	300	150	600	350	50	18	714	71,0
ENR 40-125	1,5	90S	40	65	80	140	112	900	390	300	150	600	350	50	18	764	74,0
ENR 40-125	2,2	90L	40	65	80	140	112	900	390	300	150	600	350	50	18	764	77,0
ENR 40-125	3	100L	40	65	80	140	112	900	390	300	150	600	350	50	18	844	87,0
ENR 40-125	5,5	132S	40	65	80	140	132	900	490	380	150	600	440	50	18	926	114,0
ENR 40-160	1,5	90S	40	65	80	160	132	900	390	300	150	600	350	50	18	764	82,0
ENR 40-160	2,2	90L	40	65	80	160	132	900	390	300	150	600	350	50	18	764	83,0
ENR 40-160	3	100L	40	65	80	160	132	900	390	300	150	600	350	50	18	844	93,0
ENR 40-160	4	112	40	65	80	160	132	900	490	380	150	600	440	50	18	844	104,0
ENR 40-160	5,5	132S	40	65	80	160	132	900	490	380	150	600	440	50	18	926	115,0

DIMENSIONS AND WEIGHT

50Hz

Rev. 0

Dimension table 40 - 50

Model	Motor		Dimensions [mm]														[kgf]
	[Kw]	MEC	DN2	DN1	a	h2	h1	Standard coupling									
								A	B	F	Y	V	E	H	S	T	
ENR 40-200	3	100L	40	65	100	180	160	900	490	380	150	600	440	50	18	864	97,0
ENR 40-200	4	112	40	65	100	180	160	900	490	380	150	600	440	50	18	864	106,0
ENR 40-200	5,5	132S	40	65	100	180	160	900	490	380	150	600	440	50	18	946	121,0
ENR 40-200	7,5	132S	40	65	100	180	160	900	490	380	150	600	440	50	18	946	121,0
ENR 40-200	11	160M	40	65	100	180	160	1120	490	380	190	740	440	50	22	1112	167,0
ENR 40-200	15	160M	40	65	100	180	160	1120	490	380	190	740	440	50	22	1112	167,0
ENR 40-250	7,5	132S	40	65	100	225	180	900	490	380	150	600	440	50	18	946	12,0
ENR 40-250	11	160M	40	65	100	225	180	1120	490	380	190	740	440	50	22	1112	178,0
ENR 40-250	15	160M	40	65	100	225	180	1120	490	380	190	740	440	50	22	1112	178,0
ENR 40-250	18,5	160L	40	65	100	225	180	1120	610	480	190	740	550	50	22	1112	201,0
ENR 40-250	22	180M	40	65	100	225	180	1120	610	480	190	740	550	50	22	1150	224,0
ENR 40-315	15	160M	40	65	125	250	225	1400	610	480	230	940	550	75	26	1247	242,0
ENR 40-315	18,5	160L	40	65	125	250	225	1400	610	480	230	940	550	75	26	1247	256,0
ENR 40-315	22	180M	40	65	125	250	225	1400	610	480	230	940	550	75	26	1285	280,0
ENR 40-315	30	200L	40	65	125	250	225	1400	610	480	230	940	550	75	26	1322	345,0
ENR 40-315	37	200L	40	65	125	250	225	1400	610	480	230	940	550	75	26	1322	345,0
ENR 50-125	1,5	90S	50	65	100	160	132	900	390	300	150	600	350	50	18	784	82,0
ENR 50-125	2,2	90L	50	65	100	160	132	900	390	300	150	600	350	50	18	784	83,0
ENR 50-125	3	100L	50	65	100	160	132	900	390	300	150	600	350	50	18	864	93,0
ENR 50-125	4	112	50	65	100	160	132	900	490	380	150	600	440	50	18	864	104,0
ENR 50-125	5,5	132S	50	65	100	160	132	900	490	380	150	600	440	50	18	946	115,0
ENR 50-125	7,5	132S	50	65	100	160	132	900	490	380	150	600	440	50	18	946	115,0
ENR 50-160	2,2	90L	50	65	100	180	160	900	490	380	150	600	440	50	18	784	87,0
ENR 50-160	3	100L	50	65	100	180	160	900	490	380	150	600	440	50	18	864	97,0
ENR 50-160	4	112	50	65	100	180	160	900	490	380	150	600	440	50	18	864	103,0
ENR 50-160	5,5	132S	50	65	100	180	160	900	490	380	150	600	440	50	18	946	119,0
ENR 50-160	7,5	132S	50	65	100	180	160	900	490	380	150	600	440	50	18	946	119,0
ENR 50-160	11	160M	50	65	100	180	160	1120	490	380	190	740	440	50	22	1112	165,0
ENR 50-160	15	160M	50	65	100	180	180	1120	490	380	190	740	440	50	22	1112	165,0
ENR 50-200	3	100L	50	65	100	200	160	900	490	380	150	600	440	50	18	864	102,0
ENR 50-200	4	112	50	65	100	200	160	900	490	380	150	600	440	50	18	864	109,0
ENR 50-200	5,5	132S	50	65	100	200	160	900	490	380	150	600	440	50	18	946	123,0
ENR 50-200	7,5	132S	50	65	100	200	160	900	490	380	150	600	440	50	18	946	123,0
ENR 50-200	11	160M	50	65	100	200	160	1120	490	380	190	740	440	50	22	1112	169,0
ENR 50-200	15	160M	50	65	100	200	160	1120	490	380	190	740	440	50	22	1112	169,0
ENR 50-200	18,5	160L	50	65	100	200	160	1120	490	380	190	740	440	50	22	1112	183,0
ENR 50-200	22	180M	50	65	100	200	180	1120	610	480	190	740	550	50	22	1150	217,0
ENR 50-250	15	160M	50	65	100	225	180	1120	610	480	190	740	550	50	22	1112	194,0
ENR 50-250	18,5	160L	50	65	100	225	180	1120	610	480	190	740	550	50	22	1112	207,0
ENR 50-250	22	180M	50	65	100	225	180	1120	610	480	190	740	550	50	22	1150	232,0
ENR 50-250	30	200L	50	65	100	225	200	1120	610	480	190	740	550	50	22	1187	296,0
ENR 50-315	22	180M	50	65	125	280	225	1400	610	480	230	940	550	75	26	1285	280,0
ENR 50-315	30	200L	50	65	125	280	225	1400	610	480	230	940	550	75	26	1322	345,0
ENR 50-315	37	200L	50	65	125	280	225	1400	610	480	230	940	550	75	26	1322	345,0
ENR 50-315	45	225M	50	65	125	280	225	1400	730	600	230	940	670	75	26	1429	404,0
ENR 50-315	55	250M	50	65	125	280	250	1600	660	530	270	1060	600	75	26	1429	438,0
ENR 50-315	75	280S	50	65	125	280	280	1800	730	600	300	1200	670	100	26	1559	572,0

Dimension table 65 - 80 - 100

Model	Motor		Dimensions [mm]														[kgf]
	[Kw]	MEC	DN2	DN1	a	h2	h1	Standard coupling								[kgf]	
								A	B	F	Y	V	E	H	S		
ENR 65-125	3	100L	65	80	100	180	160	900	490	380	150	600	440	50	18	864	95,0
ENR 65-125	4	112	65	80	100	180	160	900	490	380	150	600	440	50	18	864	102,0
ENR 65-125	5,5	132S	65	80	100	180	160	900	490	380	150	600	440	50	18	946	117,0
ENR 65-125	7,5	132S	65	80	100	180	160	900	490	380	150	600	440	50	18	946	117,0
ENR 65-125	11	160M	65	80	100	180	160	1120	490	380	190	740	440	50	22	1112	163,0
ENR 65-160	5,5	132S	65	80	100	200	160	900	490	380	150	600	440	50	18	946	122,0
ENR 65-160	7,5	132S	65	80	100	200	160	900	490	380	150	600	440	50	18	946	122,0
ENR 65-160	11	160M	65	80	100	200	160	1120	490	380	190	740	440	50	22	1112	168,0
ENR 65-160	15	160M	65	80	100	200	160	1120	490	380	190	740	440	50	22	1112	168,0
ENR 65-160	18,5	160L	65	80	100	200	160	1120	490	380	190	740	440	50	22	1112	182,0
ENR 65-200	11	160M	65	80	100	225	180	1120	610	480	190	740	550	50	22	1112	186,0
ENR 65-200	15	160M	65	80	100	225	180	1120	610	480	190	740	550	50	22	1112	186,0
ENR 65-200	18,5	160L	65	80	100	225	180	1120	610	480	190	740	550	50	22	1112	200,0
ENR 65-200	22	180M	65	80	100	225	180	1120	610	480	190	740	550	50	22	1150	225,0
ENR 65-200	30	200L	65	80	100	225	200	1120	610	480	190	740	550	50	22	1187	288,0
ENR 65-250	18,5	160L	65	80	100	250	200	1400	610	480	230	940	550	75	26	1222	249,0
ENR 65-250	22	180M	65	80	100	250	200	1400	610	480	230	940	550	75	26	1260	273,0
ENR 65-250	30	200L	65	80	100	250	200	1400	610	480	230	940	550	75	26	1297	337,0
ENR 65-250	37	200L	65	80	100	250	200	1400	610	480	230	940	550	75	26	1297	337,0
ENR 65-250	45	225M	65	80	100	250	225	1400	730	600	230	940	670	75	26	1404	396,0
ENR 80-160	7,5	132S	80	100	125	225	180	1120	490	380	190	740	440	50	22	971	143,0
ENR 80-160	11	160M	80	100	125	225	180	1120	610	480	190	740	550	50	22	1137	182,0
ENR 80-160	15	160M	80	100	125	225	180	1120	610	480	190	740	550	50	22	1137	182,0
ENR 80-160	18,5	160L	80	100	125	225	180	1120	610	480	190	740	550	50	22	1137	196,0
ENR 80-160	22	180M	80	100	125	225	180	1120	610	480	190	740	550	50	22	1175	220,0
ENR 80-160	30	200L	80	100	125	225	200	1120	610	480	190	740	550	50	22	1212	284,0
ENR 80-200	15	160M	80	100	125	250	180	1400	610	480	230	940	550	75	26	1247	224,0
ENR 80-200	18,5	160L	80	100	125	250	180	1400	610	480	230	940	550	75	26	1247	238,0
ENR 80-200	22	180M	80	100	125	250	180	1400	610	480	230	940	550	75	26	1285	262,0
ENR 80-200	30	200L	80	100	125	250	200	1400	610	480	230	940	550	75	26	1322	327,0
ENR 80-200	37	200L	80	100	125	250	200	1400	610	480	230	940	550	75	26	1322	327,0
ENR 80-200	45	225M	80	100	125	250	225	1400	730	600	230	940	670	75	26	1429	385,0
ENR 80-250	22	180M	80	100	125	280	200	1400	610	480	230	940	550	75	26	1285	275,0
ENR 80-250	30	200L	80	100	125	280	200	1400	610	480	230	940	550	75	26	1322	338,0
ENR 80-250	37	200L	80	100	125	280	200	1400	610	480	230	940	550	75	26	1322	338,0
ENR 80-250	45	225M	80	100	125	280	225	1400	730	600	230	940	670	75	26	1429	397,0
ENR 80-250	55	250M	80	100	125	280	250	1600	660	530	270	1060	600	75	26	1429	431,0
ENR 80-250	75	280S	80	100	125	280	280	1800	730	600	300	1200	670	100	26	1559	565,0
ENR 100-160	18,5	160L	100	125	125	280	200	1400	610	480	230	940	550	75	26	1247	242,0
ENR 100-160	22	180M	100	125	125	280	200	1400	610	480	230	940	550	75	26	1285	266,0
ENR 100-160	30	200L	100	125	125	280	200	1400	610	480	230	940	550	75	26	1322	330,0
ENR 100-160	37	200L	100	125	125	280	200	1400	610	480	230	940	550	75	26	1322	330,0
ENR 100-200	18,5	160L	100	125	125	280	200	1400	610	480	230	940	550	75	26	1247	245,0
ENR 100-200	22	180M	100	125	125	280	200	1400	610	480	230	940	550	75	26	1285	269,0
ENR 100-200	30	200L	100	125	125	280	200	1400	610	480	230	940	550	75	26	1322	333,0
ENR 100-200	37	200L	100	125	125	280	200	1400	610	480	230	940	550	75	26	1322	333,0
ENR 100-200	45	225M	100	125	125	280	225	1400	730	600	230	940	670	75	26	1429	392,0
ENR 100-200	75	280S	100	125	125	280	280	1800	730	600	300	1200	670	100	26	1559	560,0

Dimension table 100 – 125

MODEL	MOTOR		DIMENSIONS [mm]														[kgf]
	[Kw]	MEC	DN2	DN1	a	h2	h1	STANDARD COUPLING									
								A	B	F	Y	V	E	H	S	T	
ENR 100-250	30	200L	100	125	140	280	225	1400	730	600	230	940	670	75	26	1337	368,0
ENR 100-250	37	200L	100	125	140	280	225	1400	730	600	230	940	670	75	26	1337	368,0
ENR 100-250	45	225M	100	125	140	280	225	1600	660	530	270	1060	600	75	26	1444	417,0
ENR 100-250	55	250M	100	125	140	280	250	1600	660	530	270	1060	600	75	26	1444	447,0
ENR 100-250	75	280S	100	125	140	280	280	1800	730	600	300	1200	670	100	26	1574	581,0
ENR 100-250	90	280M	100	125	140	280	280	1800	730	600	300	1200	670	100	26	1574	627,0
ENR 125-200	37	200L	125	150	140	315	250	1400	730	600	230	940	670	75	26	1337	383,0
ENR 125-200	45	225M	125	150	140	315	250	1600	660	530	270	1060	600	75	26	1444	432,0
ENR 125-200	55	250M	125	150	140	315	250	1600	660	530	270	1060	600	75	26	1444	462,0
ENR 125-200	75	280S	125	150	140	315	280	1800	730	600	300	1200	670	100	26	1574	595,0
ENR 125-200	90	280M	125	150	140	315	280	1800	730	600	300	1200	670	100	26	1574	641,0
ENR 125-200	110	315S	125	150	140	315	315	1800	850	700	300	1200	780	100	26	1574	670,0

DIMENSIONS AND WEIGHT

50Hz

Rev. 0

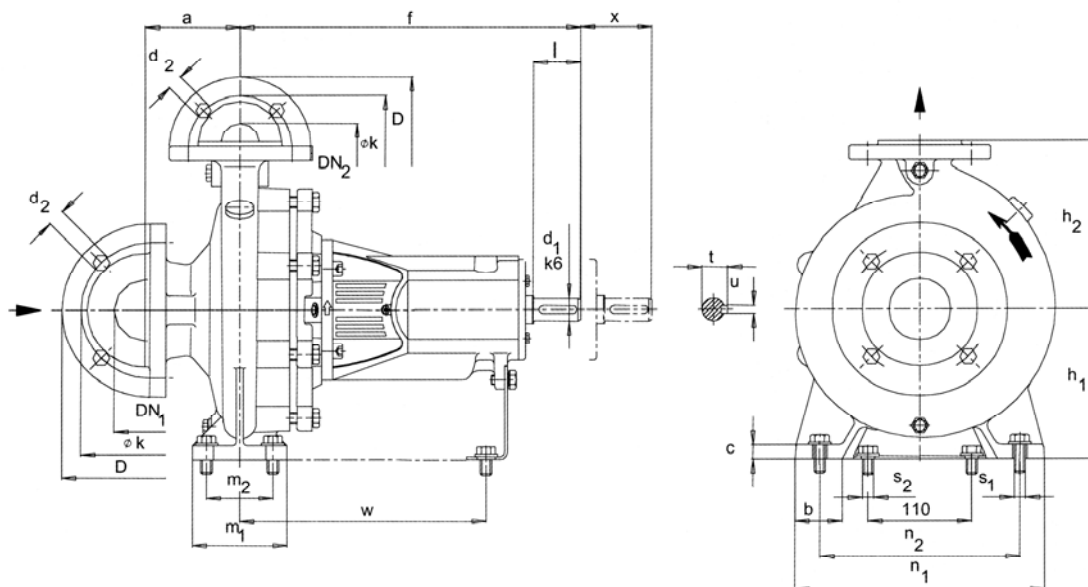

Model	Supp	Dimensions [mm]																				Weight [kgf]
		Pump						Support						Shaft protuberance								
		DN2	DN1	a	f	h2	h1	b	c	m1	m2	n1	n2	s1	s2	w	x	d1	l	t	u	
ENR 32-125	25	32	50	80	360	112	140	50	15	100	70	190	140	M12	M12	260	100	24	50	27	8	31,0
ENR 32-160	25	32	50	80	360	132	160	50	15	100	70	240	190	M12	M12	260	100	24	50	27	8	33,0
ENR 32-200	25	32	50	80	360	160	180	50	15	100	70	240	190	M12	M12	260	100	24	50	27	8	34,0
ENR 32-250	25	32	50	100	360	180	225	65	15	125	95	320	250	M12	M12	260	100	24	50	27	8	46,0
ENR 40-125	25	40	65	80	360	112	140	50	15	100	70	210	160	M12	M12	260	100	24	50	27	8	28,0
ENR 40-160	25	40	65	80	360	132	160	50	15	100	70	240	190	M12	M12	260	100	24	50	27	8	30,0
ENR 40-200	25	40	65	100	360	160	180	50	15	100	70	265	212	M12	M12	260	100	24	50	27	8	36,0
ENR 40-250	25	40	65	100	360	180	225	65	15	125	95	320	250	M12	M12	260	100	24	50	27	8	46,0
ENR 40-315	35	40	65	125	470	225	250	65	18	125	95	345	280	M12	M12	340	100	32	80	35	10	73,0
ENR 50-125	25	50	65	100	360	132	160	50	15	100	70	240	190	M12	M12	260	100	24	50	27	8	30,0
ENR 50-160	25	50	65	100	360	160	180	50	15	100	70	265	212	M12	M12	260	100	24	50	27	8	36,0
ENR 50-200	25	50	65	100	360	160	200	50	15	100	70	265	212	M12	M12	260	100	24	50	27	8	40,0
ENR 50-250	25	50	65	100	360	180	225	65	15	125	95	320	250	M12	M12	260	100	24	50	27	8	50,0
ENR 50-315	35	50	65	125	470	225	280	65	17	125	95	345	280	M12	M12	340	100	32	80	35	10	88,0
ENR 65-125	25	65	80	100	360	160	180	65	15	125	95	280	212	M12	M12	260	100	24	50	27	8	33,0
ENR 65-160	25	65	80	100	360	160	200	65	15	125	95	280	212	M12	M12	260	100	24	50	27	8	39,0
ENR 65-200	25	65	80	100	360	180	225	65	15	125	95	320	250	M12	M12	260	140	24	50	27	8	45,0
ENR 65-250	35	65	80	100	470	200	250	80	15	160	120	360	280	M16	M12	340	140	32	80	35	10	70,0
ENR 80-160	25	80	100	125	360	180	225	65	15	125	95	320	250	M12	M12	260	140	24	50	27	8	43,0
ENR 80-200	35	80	100	125	470	180	250	65	15	125	95	345	280	M12	M12	340	140	32	80	35	10	60,0
ENR 80-250	35	80	100	125	470	200	280	80	18	160	120	400	315	M16	M12	340	140	32	80	35	10	75,0
ENR 100-160	35	100	125	125	470	200	280	80	18	160	120	360	280	M16	M12	340	140	32	80	35	10	78,0
ENR 100-200	35	100	125	125	470	200	280	80	18	160	120	360	280	M16	M12	340	140	32	80	35	10	70,0
ENR 100-250	35	100	125	140	470	225	280	80	18	160	120	400	315	M16	M12	340	140	32	80	35	10	85,0
ENR 125-200	35	125	150	140	470	250	315	80	18	160	120	400	315	M16	M12	340	140	32	80	35	10	100,0

MOTOR DATA ENR 32 - 40 - 50

Pump type Three Phase	Power		Efficiency Three Phase	Efficiency (%) Three phase η %			Input [kW]	Full load current [A]			Locked rotor current [A]		
	[kW]	[HP]		50%	75%	100%		230 V	400 V	690 V	230 V	400 V	690 V
ENR 32-125/0,75	0,75	1	IE2	77,3	78,5	80,5	0,92	2,9	1,7	-	24,7	14,3	-
ENR 32-125/1,1	1,1	1,5	IE2	79,5	81,2	81,5	1,35	4,3	2,5	-	41,1	23,8	-
ENR 32-125/1,5	1,5	2	IE2	81,0	82,8	82,8	1,77	5,5	3,2	-	56,0	32,3	-
ENR 32-125/2,2	2,2	3	IE2	82,5	84,0	84,0	2,59	7,6	4,4	-	77,0	44,4	-
ENR 32-160/1,5	1,5	2	IE2	81,0	82,8	82,8	1,77	5,5	3,2	-	56,0	32,3	-
ENR 32-160/2,2	2,2	3	IE2	82,5	84,0	84,0	2,59	7,6	4,4	-	77,0	44,4	-
ENR 32-160/3	3	4	IE2	84,1	85,8	85,5	3,43	10,2	5,9	-	105,3	60,8	-
ENR 32-160/4	4	5,5	IE2	85,5	87,0	86,8	4,63	13,2	7,6	-	140,9	81,3	-
ENR 32-160/5,5	5,5	7,5	IE2	86,0	88,0	87,9	6,29	-	10,2	5,9	-	87,7	50,6
ENR 32-200/2,2	2,2	3	IE2	82,5	84,0	84,0	2,59	7,6	4,4	-	77,0	44,4	-
ENR 32-200/3	3	4	IE2	84,1	85,8	85,5	3,43	10,2	5,9	-	105,3	60,8	-
ENR 32-200/4	4	5,5	IE2	85,5	87,0	86,8	4,63	13,2	7,6	-	140,9	81,3	-
ENR 32-200/5,5	5,5	7,5	IE2	86,0	88,0	87,9	6,29	-	10,2	5,9	-	87,7	50,6
ENR 32-200/7,5	7,5	10	IE2	86,3	88,6	88,4	8,51	-	13,8	8,0	-	122,8	70,9
ENR 32-200/11	11	15	IE2	88,9	90,2	90,0	12,30	-	20,4	11,8	-	189,7	109,5
ENR 32-250/7,5	7,5	10	IE2	86,3	88,6	88,4	8,51	-	13,8	8,0	-	122,8	70,9
ENR 32-250/11	11	15	IE2	88,9	90,2	90,0	12,30	-	20,4	11,8	-	189,7	109,5
ENR 32-250/15	15	20	IE2	90,0	91,0	90,8	16,58	-	27,2	15,7	-	261,1	150,8
ENR 32-250/18,5	18,5	25	IE2	90,3	91,6	91,2	20,30	-	33,3	19,2	-	319,7	184,6
ENR 40-125/1,1	1,1	1,5	IE2	79,5	81,2	81,5	1,35	4,3	2,5	-	41,1	23,8	-
ENR 40-125/1,5	1,5	2	IE2	81,0	82,8	82,8	1,77	5,5	3,2	-	56,0	32,3	-
ENR 40-125/2,2	2,2	3	IE2	82,5	84,0	84,0	2,59	7,6	4,4	-	77,0	44,4	-
ENR 40-125/3	3	4	IE2	84,1	85,8	85,5	3,43	10,2	5,9	-	105,3	60,8	-
ENR 40-125/5,5	5,5	7,5	IE2	86,0	88,0	87,9	6,29	-	10,2	5,9	-	87,7	50,6
ENR 40-160/1,5	1,5	2	IE2	81,0	82,8	82,8	1,77	5,5	3,2	-	56,0	32,3	-
ENR 40-160/2,2	2,2	3	IE2	82,5	84,0	84,0	2,59	7,6	4,4	-	77,0	44,4	-
ENR 40-160/3	3	4	IE2	84,1	85,8	85,5	3,43	10,2	5,9	-	105,3	60,8	-
ENR 40-160/4	4	5,5	IE2	85,5	87,0	86,8	4,63	13,2	7,6	-	140,9	81,3	-
ENR 40-160/5,5	5,5	7,5	IE2	86,0	88,0	87,9	6,29	-	10,2	5,9	-	87,7	50,6
ENR 40-200/3	3	4	IE2	84,1	85,8	85,5	3,43	10,2	5,9	-	105,3	60,8	-
ENR 40-200/4	4	5,5	IE2	85,5	87,0	86,8	4,63	13,2	7,6	-	140,9	81,3	-
ENR 40-200/5,5	5,5	7,5	IE2	86,0	88,0	87,9	6,29	-	10,2	5,9	-	87,7	50,6
ENR 40-200/7,5	7,5	10	IE2	86,3	88,6	88,4	8,51	-	13,8	8,0	-	122,8	70,9
ENR 40-200/11	11	15	IE2	88,9	90,2	90,0	12,30	-	20,4	11,8	-	189,7	109,5
ENR 40-200/15	15	20	IE2	90,0	91,0	90,8	16,58	-	27,2	15,7	-	261,1	150,8
ENR 40-250/7,5	7,5	10	IE2	86,3	88,6	88,4	8,51	-	13,8	8,0	-	122,8	70,9
ENR 40-250/11	11	15	IE2	88,9	90,2	90,0	12,30	-	20,4	11,8	-	189,7	109,5
ENR 40-250/15	15	20	IE2	90,0	91,0	90,8	16,58	-	27,2	15,7	-	261,1	150,8
ENR 40-250/18,5	18,5	25	IE2	90,3	91,6	91,2	20,30	-	33,3	19,2	-	319,7	184,6
ENR 40-250/22	22	30	IE2	90,9	91,8	91,4	24,07	-	39,0	22,5	-	292,8	169,0
ENR 40-315/15	15	20	IE2	90,0	91,0	90,8	16,58	-	27,2	15,7	-	261,1	150,8
ENR 40-315/18,5	18,5	25	IE2	90,3	91,6	91,2	20,30	-	33,3	19,2	-	319,7	184,6
ENR 40-315/22	22	30	IE2	90,9	91,8	91,4	24,07	-	39,0	22,5	-	292,8	169,0
ENR 40-315/30	30	40	IE2	91,3	92,3	92,4	32,50	-	53,3	30,8	-	357,1	206,2
ENR 40-315/37	37	50	IE2	91,6	92,9	92,8	39,91	-	64,0	37,0	-	403,2	232,8
ENR 50-125/1,5	1,5	2	IE2	81,0	82,8	82,8	1,77	5,5	3,2	-	56,0	32,3	-
ENR 50-125/2,2	2,2	3	IE2	82,5	84,0	84,0	2,59	7,6	4,4	-	77,0	44,4	-
ENR 50-125/3	3	4	IE2	84,1	85,8	85,5	3,43	10,2	5,9	-	105,3	60,8	-
ENR 50-125/4	4	5,5	IE2	85,5	87,0	86,8	4,63	13,2	7,6	-	140,9	81,3	-
ENR 50-125/5,5	5,5	7,5	IE2	86,0	88,0	87,9	6,29	-	10,2	5,9	-	87,7	50,6
ENR 50-125/7,5	7,5	10	IE2	86,3	88,6	88,4	8,51	-	13,8	8,0	-	122,8	70,9

TECHNICAL DATA

50Hz

Rev. 0

MOTOR DATA ENR 50 - 65

Pump type Three Phase	Power		Efficiency Three Phase	Efficiency (%) Three phase η %			Input [kW]	Full load current [A]			Locked rotor current [A]		
	[kW]	[HP]		50%	75%	100%		230 V	400 V	690 V	230 V	400 V	690 V
ENR 50-160/2,2	2,2	3	IE2	82,5	84,0	84,0	2,59	7,6	4,4	-	77,0	44,4	-
ENR 50-160/3	3	4	IE2	84,1	85,8	85,5	3,43	10,2	5,9	-	105,3	60,8	-
ENR 50-160/4	4	5,5	IE2	85,5	87,0	86,8	4,63	13,2	7,6	-	140,9	81,3	-
ENR 50-160/5,5	5,5	7,5	IE2	86,0	88,0	87,9	6,29	-	10,2	5,9	-	87,7	50,6
ENR 50-160/7,5	7,5	10	IE2	86,3	88,6	88,4	8,51	-	13,8	8,0	-	122,8	70,9
ENR 50-160/11	11	15	IE2	88,9	90,2	90,0	12,30	-	20,4	11,8	-	189,7	109,5
ENR 50-160/15	15	20	IE2	90,0	91,0	90,8	16,58	-	27,2	15,7	-	261,1	150,8
ENR 50-200/3	3	4	IE2	84,1	85,8	85,5	3,43	10,2	5,9	-	105,3	60,8	-
ENR 50-200/4	4	5,5	IE2	85,5	87,0	86,8	4,63	13,2	7,6	-	140,9	81,3	-
ENR 50-200/5,5	5,5	7,5	IE2	86,0	88,0	87,9	6,29	-	10,2	5,9	-	87,7	50,6
ENR 50-200/7,5	7,5	10	IE2	86,3	88,6	88,4	8,51	-	13,8	8,0	-	122,8	70,9
ENR 50-200/11	11	15	IE2	88,9	90,2	90,0	12,30	-	20,4	11,8	-	189,7	109,5
ENR 50-200/15	15	20	IE2	90,0	91,0	90,8	16,58	-	27,2	15,7	-	261,1	150,8
ENR 50-200/18,5	18,5	25	IE2	90,3	91,6	91,2	20,30	-	33,3	19,2	-	319,7	184,6
ENR 50-200/22	22	30	IE2	90,9	91,8	91,4	24,07	-	39,0	22,5	-	292,8	169,0
ENR 50-250/15	15	20	IE2	90,0	91,0	90,8	16,58	-	27,2	15,7	-	261,1	150,8
ENR 50-250/18,5	18,5	25	IE2	90,3	91,6	91,2	20,30	-	33,3	19,2	-	319,7	184,6
ENR 50-250/22	22	30	IE2	90,9	91,8	91,4	24,07	-	39,0	22,5	-	292,8	169,0
ENR 50-250/30	30	40	IE2	91,3	92,3	92,4	32,50	-	53,3	30,8	-	357,1	206,2
ENR 50-315/22	22	30	IE2	90,9	91,8	91,4	24,07	-	39,0	22,5	-	292,8	169,0
ENR 50-315/30	30	40	IE2	91,3	92,3	92,4	32,50	-	53,3	30,8	-	357,1	206,2
ENR 50-315/37	37	50	IE2	91,6	92,9	92,8	39,91	-	64,0	37,0	-	403,2	232,8
ENR 50-315/45	45	60	IE2	92,8	93,3	93,2	48,28	-	78,3	45,2	-	540,3	311,9
ENR 50-315/55	55	75	IE2	92,9	93,8	93,7	58,67	-	94,1	54,3	-	752,8	434,6
ENR 50-315/75	75	100	IE2	93,2	94,5	94,1	79,69	-	127,8	73,8	-	1022,4	590,3
ENR 65-125/3	3	4	IE2	84,1	85,8	85,5	3,43	10,2	5,9	-	105,3	60,8	-
ENR 65-125/4	4	5,5	IE2	85,5	87,0	86,8	4,63	13,2	7,6	-	140,9	81,3	-
ENR 65-125/5,5	5,5	7,5	IE2	86,0	88,0	87,9	6,29	-	10,2	5,9	-	87,7	50,6
ENR 65-125/7,5	7,5	10	IE2	86,3	88,6	88,4	8,51	-	13,8	8,0	-	122,8	70,9
ENR 65-125/11	11	15	IE2	88,9	90,2	90,0	12,30	-	20,4	11,8	-	189,7	109,5
ENR 65-160/5,5	5,5	7,5	IE2	86,0	88,0	87,9	6,29	-	10,2	5,9	-	87,7	50,6
ENR 65-160/7,5	7,5	10	IE2	86,3	88,6	88,4	8,51	-	13,8	8,0	-	122,8	70,9
ENR 65-160/11	11	15	IE2	88,9	90,2	90,0	12,30	-	20,4	11,8	-	189,7	109,5
ENR 65-160/15	15	20	IE2	90,0	91,0	90,8	16,58	-	27,2	15,7	-	261,1	150,8
ENR 65-160/18,5	18,5	25	IE2	90,3	91,6	91,2	20,30	-	33,3	19,2	-	319,7	184,6
ENR 65-200/11	11	15	IE2	88,9	90,2	90,0	12,30	-	20,4	11,8	-	189,7	109,5
ENR 65-200/15	15	20	IE2	90,0	91,0	90,8	16,58	-	27,2	15,7	-	261,1	150,8
ENR 65-200/18,5	18,5	25	IE2	90,3	91,6	91,2	20,30	-	33,3	19,2	-	319,7	184,6
ENR 65-200/22	22	30	IE2	90,9	91,8	91,4	24,07	-	39,0	22,5	-	292,8	169,0
ENR 65-200/30	30	40	IE2	91,3	92,3	92,4	32,50	-	53,3	30,8	-	357,1	206,2
ENR 65-250/18,5	18,5	25	IE2	90,3	91,6	91,2	20,30	-	33,3	19,2	-	319,7	184,6
ENR 65-250/22	22	30	IE2	90,9	91,8	91,4	24,07	-	39,0	22,5	-	292,8	169,0
ENR 65-250/30	30	40	IE2	91,3	92,3	92,4	32,50	-	53,3	30,8	-	357,1	206,2
ENR 65-250/37	37	50	IE2	91,6	92,9	92,8	39,91	-	64,0	37,0	-	403,2	232,8
ENR 65-250/45	45	60	IE2	92,8	93,3	93,2	48,28	-	78,3	45,2	-	540,3	311,9

TECHNICAL DATA

50Hz

Rev. 0

MOTOR DATA ENR 80 - 100 - 125

Pump type Three Phase	Power		Efficiency Three Phase	Efficiency (%) Three phase η %			Input [kW]	Full load current [A]			Locked rotor current [A]		
	[kW]	[HP]		50%	75%	100%		230 V	400 V	690 V	230 V	400 V	690 V
ENR 80-160/7,5	7,5	10	IE2	86,3	88,6	88,4	8,51	-	13,8	8,0	-	122,8	70,9
ENR 80-160/11	11	15	IE2	88,9	90,2	90,0	12,30	-	20,4	11,8	-	189,7	109,5
ENR 80-160/15	15	20	IE2	90,0	91,0	90,8	16,58	-	27,2	15,7	-	261,1	150,8
ENR 80-160/18,5	18,5	25	IE2	90,3	91,6	91,2	20,30	-	33,3	19,2	-	319,7	184,6
ENR 80-160/22	22	30	IE2	90,9	91,8	91,4	24,07	-	39,0	22,5	-	292,8	169,0
ENR 80-160/30	30	40	IE2	91,3	92,3	92,4	32,50	-	53,3	30,8	-	357,1	206,2
ENR 80-200/15	15	20	IE2	90,0	91,0	90,8	16,58	-	27,2	15,7	-	261,1	150,8
ENR 80-200/18,5	18,5	25	IE2	90,3	91,6	91,2	20,30	-	33,3	19,2	-	319,7	184,6
ENR 80-200/22	22	30	IE2	90,9	91,8	91,4	24,07	-	39,0	22,5	-	292,8	169,0
ENR 80-200/30	30	40	IE2	91,3	92,3	92,4	32,50	-	53,3	30,8	-	357,1	206,2
ENR 80-200/37	37	50	IE2	91,6	92,9	92,8	39,91	-	64,0	37,0	-	403,2	232,8
ENR 80-200/45	45	60	IE2	92,8	93,3	93,2	48,28	-	78,3	45,2	-	540,3	311,9
ENR 80-250/22	22	30	IE2	90,9	91,8	91,4	24,07	-	39,0	22,5	-	292,8	169,0
ENR 80-250/30	30	40	IE2	91,3	92,3	92,4	32,50	-	53,3	30,8	-	357,1	206,2
ENR 80-250/37	37	50	IE2	91,6	92,9	92,8	39,91	-	64,0	37,0	-	403,2	232,8
ENR 80-250/45	45	60	IE2	92,8	93,3	93,2	48,28	-	78,3	45,2	-	540,3	311,9
ENR 80-250/55	55	75	IE2	92,9	93,8	93,7	58,67	-	94,1	54,3	-	752,8	434,6
ENR 80-250/75	75	100	IE2	93,2	94,5	94,1	79,69	-	127,8	73,8	-	1022,4	590,3
ENR 100-160/18,5	18,5	25	IE2	90,3	91,6	91,2	20,30	-	33,3	19,2	-	319,7	184,6
ENR 100-160/22	22	30	IE2	90,9	91,8	91,4	24,07	-	39,0	22,5	-	292,8	169,0
ENR 100-160/30	30	40	IE2	91,3	92,3	92,4	32,50	-	53,3	30,8	-	357,1	206,2
ENR 100-160/37	37	50	IE2	91,6	92,9	92,8	39,91	-	64,0	37,0	-	403,2	232,8
ENR 100-200/18,5	18,5	25	IE2	90,3	91,6	91,2	20,30	-	33,3	19,2	-	319,7	184,6
ENR 100-200/22	22	30	IE2	90,9	91,8	91,4	24,07	-	39,0	22,5	-	292,8	169,0
ENR 100-200/30	30	40	IE2	91,3	92,3	92,4	32,50	-	53,3	30,8	-	357,1	206,2
ENR 100-200/37	37	50	IE2	91,6	92,9	92,8	39,91	-	64,0	37,0	-	403,2	232,8
ENR 100-200/45	45	60	IE2	92,8	93,3	93,2	48,28	-	78,3	45,2	-	540,3	311,9
ENR 100-200/75	75	100	IE2	93,2	94,5	94,1	79,69	-	127,8	73,8	-	1022,4	590,3
ENR 100-250/30	30	40	IE2	91,3	92,3	92,4	32,50	-	53,3	30,8	-	357,1	206,2
ENR 100-250/37	37	50	IE2	91,6	92,9	92,8	39,91	-	64,0	37,0	-	403,2	232,8
ENR 100-250/45	45	60	IE2	92,8	93,3	93,2	48,28	-	78,3	45,2	-	540,3	311,9
ENR 100-250/55	55	75	IE2	92,9	93,8	93,7	58,67	-	94,1	54,3	-	752,8	434,6
ENR 100-250/75	75	100	IE2	93,2	94,5	94,1	79,69	-	127,8	73,8	-	1022,4	590,3
ENR 100-250/90	90	120	IE2	94	94,3	94,4	95,33	-	151,2	87,3	-	1164,2	672,2
ENR 125-200/37	37	50	IE2	91,6	92,9	92,8	39,91	-	64,0	37,0	-	403,2	232,8
ENR 125-200/45	45	60	IE2	92,8	93,3	93,2	48,28	-	78,3	45,2	-	540,3	311,9
ENR 125-200/55	55	75	IE2	92,9	93,8	93,7	58,67	-	94,1	54,3	-	752,8	434,6
ENR 125-200/75	75	100	IE2	93,2	94,5	94,1	79,69	-	127,8	73,8	-	1022,4	590,3
ENR 125-200/90	90	120	IE2	94	94,3	94,4	95,33	-	151,2	87,3	-	1164,2	672,2
ENR 125-200/110	110	150	IE2	93,7	94,6	94,8	115,98	-	186,0	107,4	-	1432,2	826,9

NOISE DATA

Power		L _{pA} - dB(A) *
[kW]	[HP]	
0,75	1	<70
1,1	1,5	
1,5	2	
2,2	3	
3	4	72
4	5,5	78
5,5	7,5	80
7,5	10	
11	15	
15	20	81
18,5	25	
22	30	
30	40	83
37	55	85
45	60	
55	75	86
75	100	88
90	125	90
110	150	92

* Mean value of several measures at 1m distance around the pump. Tolerance ± 2.5 dB.

LENNTECH
WATER TREATMENT SOLUTIONS

info@lennotech.com Tel. +31-152-610-900

www.lennotech.com Fax. +31-152-616-289

FAMCO
هایپر صنعت



	Page
- SPECIFICATIONS	200
SELECTION CHART	201
TYPE KEY AND CURVE SPECIFICATIONS	218
PERFORMANCE CURVE ENR 32-125	220
PERFORMANCE CURVE ENR 32-160A	221
PERFORMANCE CURVE ENR 32-160B	222
PERFORMANCE CURVE ENR 32-200A	223
PERFORMANCE CURVE ENR 32-200B	224
PERFORMANCE CURVE ENR 32-250	225
PERFORMANCE CURVE ENR 40-125	226
PERFORMANCE CURVE ENR 40-160	227
PERFORMANCE CURVE ENR 40-200	228
PERFORMANCE CURVE ENR 40-250	229
PERFORMANCE CURVE ENR 40-315	230
PERFORMANCE CURVE ENR 50-125	231
PERFORMANCE CURVE ENR 50-160	232
PERFORMANCE CURVE ENR 50-200	233
PERFORMANCE CURVE ENR 50-250	234
PERFORMANCE CURVE ENR 50-315	235
PERFORMANCE CURVE ENR 65-125	236
PERFORMANCE CURVE ENR 65-160	237
PERFORMANCE CURVE ENR 65-200	238
PERFORMANCE CURVE ENR 65-250	239
PERFORMANCE CURVE ENR 65-315	240
PERFORMANCE CURVE ENR 80-160	241
PERFORMANCE CURVE ENR 80-200	242
PERFORMANCE CURVE ENR 80-250	243
PERFORMANCE CURVE ENR 80-315	244
PERFORMANCE CURVE ENR 80-400	245
PERFORMANCE CURVE ENR 100-160	246
PERFORMANCE CURVE ENR 100-200	247
PERFORMANCE CURVE ENR 100-250	248
PERFORMANCE CURVE ENR 100-315	249
PERFORMANCE CURVE ENR 100-400	250
PERFORMANCE CURVE ENR 125-200	251
PERFORMANCE CURVE ENR 125-250	252
PERFORMANCE CURVE ENR 125-315	253
PERFORMANCE CURVE ENR 125-400	254
PERFORMANCE CURVE ENR 150-200	255
PERFORMANCE CURVE ENR 150-250	256
PERFORMANCE CURVE ENR 150-315	257
PERFORMANCE CURVE ENR 150-400	258
PERFORMANCE CURVE ENR 150-500	259
PERFORMANCE CURVE ENR 200-250	260

- CONSTRUCTIONS	300
SECTIONAL VIEW	300
- DIMENSIONS AND WEIGHT	400
PUMP WITH MOTOR 32-40-50	400
PUMP WITH MOTOR 50-65-80	401
PUMP WITH MOTOR 80-100-125-150	402
PUMP WITH MOTOR 150-200	403
PUMP WITHOUT MOTOR	404
- TECHNICAL DATA	500
MOTOR DATA 32-40-50	500
MOTOR DATA 50-65-80	501
MOTOR DATA 80-100-125	502
MOTOR DATA 125-150-200	503
NOISE DATA	504

SPECIFICATION

50Hz

Rev. 0

PUMP		
Liquid Handled	Type of liquid	Clean water
	Temperature [°C]	min. -20 max +120
Maximum working pressure	[MPa]	1.47
Flange		UNI 2236
Counterflange (On request)		UNI 2247
Construction	Impeller	Closed centrifugal type
	Shaft seal type	Mechanical seal
	Bearing	Sealed ball bearing
Pipe Connection	Suction	Flange to DIN 2532
	Discharge	Flange to DIN 2532
Material	Casing	CAST IRON
	Impeller	CAST IRON / BRONZE
	Shaft seal	SiC/Carbon/EPDM
	Shaft	AISI 420
	Bracket	CAST IRON
Applicable standard of test		ISO 9906 – Annex A

MOTOR		
Type	Electric - TEFC Three Phase	
Efficiency level (Reg. 640/2009)	IE2	
No. of Poles	4	
Rotation speed [min ⁻¹]	≈1400	
Insulation Class	F	
Protection degree (CEI EN 60034-5)	IP 55	
Power rating	[kW]	0.37 ÷ 90
	[HP]	0.5 ÷ 122
Frequency [Hz]	50	
Voltage [V]	400/690 ±10%	
Over load protection	Provided by the user	
Casing material	Cast Iron	

SELECTION CHART

50Hz

Rev. 0

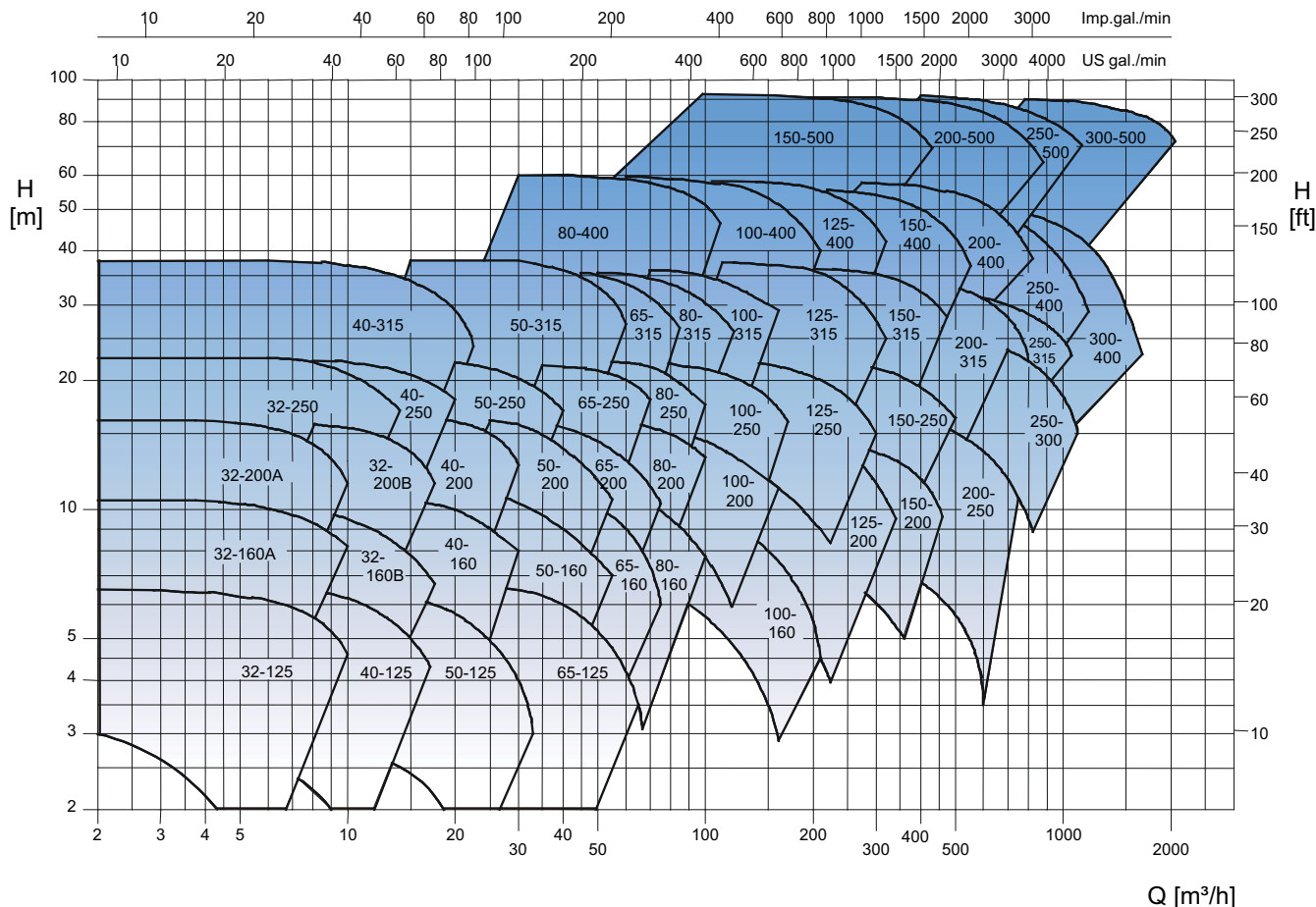

32 - 125 Version

Pump type ENR 4	Q=Capacity											
	m³/h 0	1	2	3	4	5	6	7	8	9	10	11
Three Phase	l/min 0	16,7	33,3	50	67	83	100	117	133	150	167	183
H=Total manometric head in meters												
ENR 32-125 Ø100	2,9	2,9	2,85	2,75	2,6	2,4	2	1,5	-	-	-	-
ENR 32-125 Ø110	3,6	3,6	3,55	3,5	3,4	3,2	2,9	2,5	2	-	-	-
ENR 32-125 Ø120	4,4	4,4	4,39	4,35	4,2	4	3,78	3,4	3	2,5	-	-
ENR 32-125 Ø130	5,5	5,5	5	5,49	5,4	5,25	5	4,6	4,2	3,8	3,3	-
ENR 32-125 Ø140	6,5	6,5	6,5	6,5	6,48	6,4	6,2	6	5,65	5,25	4,7	4

SELECTION CHART

50Hz

Rev. 0

32 – 160A Version

Pump type ENR 4 Three Phase	Q=Capacity									
	m ³ /h 0	2	4	6	6,8	7,5	8,2	9	9,7	10,2
	l/min 0	33,3	67	100	113	125	137	150	162	170
H=Total manometric head in meters										
ENR 32-160A Ø130	5,6	5,8	5,3	4,3	3,9	-	-	-	-	-
ENR 32-160A Ø140	6,7	6,7	6,5	5,6	5	4,5	-	-	-	-
ENR 32-160A Ø150	7,8	7,9	7,7	7	6,4	6	5,3	-	-	-
ENR 32-160A Ø160	9	9	8,8	8,2	7,9	7,3	6,8	6	-	-
ENR 32-160A Ø168	10,1	10,3	10	9,6	9,2	8,8	8,2	7,5	7	-
ENR 32-160A Ø175	11,1	11,3	11,2	10,8	10,4	10	9,6	9	8,3	7,9

32 – 160B Version

Pump type ENR 4 Three Phase	Q=Capacity											
	m ³ /h 0	2	4	6	8	10	12,5	13,9	15	16,1	17	18
	l/min 0	33,3	67	100	133	167	208	232	250	268	283	300
H=Total manometric head in meters												
ENR 32-160BØ130	5,5	5,5	5,5	5,4	5	4,5	3,6	-	-	-	-	-
ENR 32-160BØ140	6,5	6,5	6,5	6,4	6	5,5	4,6	4,2	-	-	-	-
ENR 32-160BØ150	7,5	7,5	7,5	7,48	7	6,7	5,8	5,4	5	-	-	-
ENR 32-160BØ160	8,6	8,7	8,6	8,5	8,3	7,9	7,1	6,5	6,1	5,6	-	-
ENR 32-160BØ168	9,6	9,7	9,6	9,5	9,4	9	8,2	7,7	7,2	6,7	6,3	-
ENR 32-160BØ170	10,5	10,5	10,5	10,5	10,3	9,9	9,3	8,7	8,4	7,8	7,4	6,9

32 – 200A Version

Pump type ENR 4 Three Phase	Q=Capacity											
	m ³ /h 0	2	4	6	7	8	9	9,7	10,6	11,5	12	12,6
	l/min 0	33,3	67	100	117	133	150	162	177	192	200	210
H=Total manometric head in meters												
ENR 32-200A Ø170	9	9	8,8	8,2	7,9	7,4	6,7	-	-	-	-	-
ENR 32-200A Ø180	10,5	10,5	10,2	9,8	9,2	8,8	8	7,8	-	-	-	-
ENR 32-200A Ø190	12	12	11,8	11,2	10,9	10,5	9,9	9,4	8,9	-	-	-
ENR 32-200A Ø200	13,6	13,7	13,4	13	12,7	12	11,7	11	10,5	10	-	-
ENR 32-200A Ø207	14,9	14,9	14,8	14,2	13,9	13,5	12,9	12,4	11,7	11	10,8	-
ENR 32-200A Ø214	16,3	16,4	16,4	16	15,6	15	14,7	14	13,3	12,7	12	11,6

SELECTION CHART

50Hz

Rev. 0

32 – 200B Version

Pump type ENR 4 Three Phase	Q=Capacity											
	m ³ /h 0	2	4	6	8	10	13	14	15,5	16,5	17,3	18
	l/min 0	33,3	67	100	133	167	217	233	258	275	288	300
	H=Total manometric head in meters											
ENR 32-200B Ø	9,9	9,8	9,7	9,4	9,1	8,5	6,6	-	-	-	-	-
ENR 32-200B Ø	11,3	11,2	11,1	11	10,8	10,2	8,6	7,9	-	-	-	-
ENR 32-200B Ø	12,8	12,7	12,7	12,7	12,3	12	10,8	10	9	-	-	-
ENR 32-200B Ø	14,3	14,2	14,1	14	14	13,8	12,8	12	11	10,2	-	-
ENR 32-200B Ø	15,6	15,5	15,4	15,3	15,2	15	14	13,8	12,8	12	11,2	-
ENR 32-200B Ø	16,9	16,9	16,8	16,8	16,7	16,3	15,5	15	14,2	13,8	13,1	12,5

32 – 250 Version

Pump type ENR 4 Three Phase	Q=Capacity											
	m ³ /h 0	2	3	4	5	7	8	8,8	9,3	9,8	10,5	11
	l/min 0	33,3	50	67	83	117	133	147	155	163	175	183
	H=Total manometric head in meters											
ENR 32-250 Ø215	14	14	13,9	13,8	13,4	12,1	11	10	-	-	-	-
ENR 32-250 Ø215	16	16	15,9	15,9	15,4	14,2	13,1	12	11,2	-	-	-
ENR 32-250 Ø215	18	18	18	17,9	17,5	16,4	15,3	15,1	14,4	12,8	-	-
ENR 32-250 Ø215	20	20	20	19,9	19,8	18,8	17,9	16,8	16	15,2	14,1	-
ENR 32-250 Ø215	22	22	22	22	21,8	21	20	19,3	18,5	17,9	16,9	16

40 – 125 Version

Pump type ENR 4 Three Phase	Q=Capacity											
	m ³ /h 0	2	4	6	8	10	12	13,2	14	15,2	16,5	18
	l/min 0	33,3	67	100	133	167	200	220	233	253	275	300
	H=Total manometric head in meters											
ENR 40-125 Ø100	3	3	2,9	2,7	2,5	2,2	1,5	1,1	-	-	-	-
ENR 40-125 Ø110	3,6	3,6	3,6	3,5	3,4	3	2,5	2	1,7	-	-	-
ENR 40-125 Ø120	4,4	4,4	4,3	4,3	4,2	3,9	3,5	3	2,7	2,4	-	-
ENR 40-125 Ø130	5,5	5,5	5,5	5,4	5,3	5	4,6	4,3	4	3,6	3,1	-
ENR 40-125 Ø140	6,6	6,6	6,5	6,5	6,4	6,2	5,9	5,6	5,4	5	4,5	3,9

SELECTION CHART

50Hz

Rev. 0

40 – 160 Version

Pump type ENR 4 Three Phase	Q=Capacity											
	m ³ /h	0	5	10	15	20	21,0	23	26	28	30	32,5
	l/min	0	83,3	167	250	333	350	383	433	467	500	542
H=Total manometric head in meters												
ENR 40-160 Ø130	5,8	5,8	5,6	5,1	4	3,9	-	-	-	-	-	-
ENR 40-160 Ø140	7	6,9	6,6	6,4	5,5	5,1	4,5	-	-	-	-	-
ENR 40-160 Ø150	8	8	7,8	7,5	6,9	6,6	6,1	5,5	-	-	-	-
ENR 40-160 Ø160	9,3	9,3	9,2	8,8	8,1	8	7,5	7	6,2	-	-	-
ENR 40-160 Ø168	10,4	10,4	10,3	10	9,2	9,1	8,8	8,2	7,5	7	-	-
ENR 40-160 Ø175	11,4	11,4	11,3	11	10,5	10,2	10	9,5	8,9	8,4	7,6	-

40 – 200 Version

Pump type ENR 4 Three Phase	Q=Capacity											
	m ³ /h	0	5	10	15	20	24	26,2	27,5	29	31,2	32,5
	l/min	0	83,3	167	250	333	400	437	458	483	520	542
H=Total manometric head in meters												
ENR 40-200 Ø170	10,2	10,2	10	9,8	8,9	7,8	-	-	-	-	-	-
ENR 40-200 Ø180	11,8	11,8	11,7	11,2	10,6	9,5	9	-	-	-	-	-
ENR 40-200 Ø190	13,2	13,2	13	12,8	12,1	11,1	10,6	10	-	-	-	-
ENR 40-200 Ø200	14,8	14,8	14,8	14,5	14	13	12,5	11,9	11	-	-	-
ENR 40-200 Ø207	16	16	16	15,8	15,1	14,5	14	13,5	12,9	12,2	-	-
ENR 40-200 Ø214	17,4	17,4	17,3	17,1	16,8	16	15,6	15	14,6	14	13,5	-

40 – 250 Version

Pump type ENR 4 Three Phase	Q=Capacity											
	m ³ /h	0	4	8	10	12	14	18	18,8	20	20,9	22
	l/min	0	66,7	133	167	200	233	300	313	333	348	367
H=Total manometric head in meters												
ENR 40-250 Ø215	15,2	15	14,5	14	13	12	9,6	-	-	-	-	-
ENR 40-250 Ø225	16,9	16,9	16,2	15,9	15	14,2	12	11	-	-	-	-
ENR 40-250 Ø235	18,8	18,6	18	17,8	17	16	14	13,6	13	-	-	-
ENR 40-250 Ø245	20,9	20,7	20	19,8	19	18,2	16,2	16	15,1	14,5	-	-
ENR 40-250 Ø255	23	22,9	22,2	22	21,8	21	19,2	18,9	18	17,3	16,8	-

SELECTION CHART

50Hz

Rev. 0

40 – 315 Version

Pump type ENR 4 Three Phase	Q=Capacity											
	m ³ /h	0	4	8	10	12	15	16,4	17,8	19,5	21	22,5
	l/min	0	66,7	133	167	200	250	273	297	325	350	375
H=Total manometric head in meters												
ENR 40-315 Ø270	23,8	23,8	23	22	20	15,5	-	-	-	-	-	-
ENR 40-315 Ø285	26	26	25	24	22,5	18,8	17	-	-	-	-	-
ENR 40-315 Ø295	28	28	27,5	26,5	26	22,5	20,5	18,7	-	-	-	-
ENR 40-315 Ø305	31	31	30,5	30	29	26,2	24,5	22,5	19,4	-	-	-
ENR 40-315 Ø315	33,5	33	33	32,5	32	30	28,5	27	24	22	-	-
ENR 40-315 Ø325	36,5	36,5	36	35,5	35	33	32	32	28,5	26,2	23	-

50 – 125 Version

Pump type ENR 4 Three Phase	Q=Capacity										
	m ³ /h	0	2,5	5	10	15	20	23	26	29	33,5
	l/min	0	42	83	167	250	333	383	433	483	558,3
H=Total manometric head in meters											
ENR 50-125 Ø100	2,8	2,7	2,7	2,5	2	1	-	-	-	-	-
ENR 50-125 Ø110	3,6	3,65	3,6	3,4	3	2,2	1,6	-	-	-	-
ENR 50-125 Ø120	4,4	4,4	4,5	4,4	4	3,5	3	2,4	-	-	-
ENR 50-125 Ø130	5,4	5,4	5,4	5,4	5,2	4,8	4,5	4	3,2	-	-
ENR 50-125 Ø140	6,5	6,5	6	6,5	6,4	6,2	6	5,6	5	4,1	-

50 – 160 Version

Pump type ENR 4 Three Phase	Q=Capacity										
	m ³ /h	0	5	10	20	30	33	37,5	42	45	50
	l/min	0	83,3	167	333	500	550	625	700	750	833
H=Total manometric head in meters											
ENR 50-160 Ø130	5,3	5,3	5,1	4,6	3,6	3,3	-	-	-	-	-
ENR 50-160 Ø140	6,5	6,5	6,4	6	5,6	4,8	4,2	-	-	-	-
ENR 50-160 Ø150	7,7	7,6	7,6	7,3	6,5	6,2	5,7	5,2	-	-	-
ENR 50-160 Ø160	9	9	8,9	8,5	8	7,5	7,3	6,6	6	-	-
ENR 50-160 Ø175	10,6	10,6	10,5	10,4	9	9,5	9,3	8,7	8,4	7,5	-

205

SELECTION CHART

50Hz

Rev. 0

50 – 200 Version

Pump type ENR 4 Three Phase	Q=Capacity										
	m ³ /h 0	10	15	25	30	37,6	41	43	47,5	50	52
	l/min 0	167	250	417	500	627	683	717	792	833	867
H=Total manometric head in meters											
ENR 50-200 Ø170	10,2	10	9,9	9	8,5	7,4	-	-	-	-	-
ENR 50-200 Ø180	11,6	11,5	11,4	10,8	10	9	8,4	-	-	-	-
ENR 50-200 Ø190	13	12,9	12,8	12	11,6	10,6	10	9,3	-	-	-
ENR 50-200 Ø200	14,4	14,3	14,2	13,7	13	12,2	11,8	11	10,5	-	-
ENR 50-200 Ø207	15,4	15,3	15,2	14,8	14,3	13,5	13	12,5	11,9	11,4	-
ENR 50-200 Ø214	16,4	16,3	16,2	15,8	15,4	14,6	14	13,8	13	12,5	12,1

50 – 250 Version

Pump type ENR 4 Three Phase	Q=Capacity										
	m ³ /h 0	4	10	16	20	24	28	30	33,5	36	39
	l/min 0	66,7	167	267	333	400	467	500	558	600	650
H=Total manometric head in meters											
ENR 50-250 Ø215	15,6	15,5	15,1	14,7	14	13	12	-	-	-	-
ENR 50-250 Ø225	17,2	17,1	17	16,5	15,9	15	13,9	13	-	-	-
ENR 50-250 Ø235	19	19	18,9	18,3	17,8	16,9	15,9	15	14	-	-
ENR 50-250 Ø245	21	21	20,9	20,5	20	19,3	18,5	17,8	17	16	-
ENR 50-250 Ø255	23	23	22,9	22,5	22	21,5	20,9	20	19,4	18,5	17,1

50 – 315 Version

Pump type ENR 4 Three Phase	Q=Capacity										
	m ³ /h 0	5	10	15	25	30	37	41,5	45,5	49	53
	l/min 0	83,3	167	250	417	500	617	692	758	817	883
H=Total manometric head in meters											
ENR 50-315 Ø270	24,4	24,4	24,4	24,2	23	21	17	-	-	-	-
ENR 50-315 Ø285	28	28	28	27,9	26,9	25,9	22	18	-	-	-
ENR 50-315 Ø300	31,8	31,8	31,8	31,8	31	30	27,2	24	20	-	-
ENR 50-315 Ø313	34,6	34,6	34,6	34,6	34,3	34	32	28,9	25,8	21,4	-
ENR 50-315 Ø325	38	38	38	38	37,9	36,9	35,9	33	30	26	22

SELECTION CHART

50Hz

Rev. 0

65 – 125 Version

Pump type ENR 4 Three Phase	Q=Capacity								
	m ³ /h 0	10	20	30	40	43	50	60	70
	l/min 0	166,7	333	500	667	717	833	1000	1167
H=Total manometric head in meters									
ENR 65-125 Ø110	3,5	3,5	3,2	2,6	1,6	1,4	-	-	-
ENR 65-125 Ø120	4,3	4,2	4	3,6	2,8	2,5	1,7	-	-
ENR 65-125 Ø130	5,2	5,2	5	4,6	4,1	3,9	3,2	2	-
ENR 65-125 Ø143	6,6	6,6	6,5	6,4	5,9	5,7	5,2	4,2	2,8

65 – 160 Version

Pump type ENR 4 Three Phase	Q=Capacity										
	m ³ /h 0	10	20	30	40	50	54	59	65	71	75
	l/min 0	167	333	500	667	833	900	983	1083	1183	1250
H=Total manometric head in meters											
ENR 65-160 Ø130	5,1	5	5	4,6	4	2,5	-	-	-	-	-
ENR 65-160 Ø140	6,2	6,1	6	5,7	5	3,5	3	-	-	-	-
ENR 65-160 Ø150	7,2	7,1	7	6,7	6,1	5	4,5	3,5	-	-	-
ENR 65-160 Ø160	8,4	8,5	8,4	8,3	7,7	6,8	6,3	5,5	4,4	-	-
ENR 65-160 Ø168	9,6	9,6	9,6	9,5	9	8,4	7,8	7,2	6,1	5	-
ENR 65-160 Ø175	10,7	10,7	10,6	10,5	10,2	9,5	9,2	8,6	7,9	6,7	6

65 – 200 Version

Pump type ENR 4 Three Phase	Q=Capacity										
	m ³ /h 0	10	20	30	40	48	54	59	64	69	72,5
	l/min 0	167	333	500	667	800	900	983	1067	1150	1208
H=Total manometric head in meters											
ENR 65-200 Ø170	9,4	9,4	9,1	8,8	7,8	6,5	-	-	-	-	-
ENR 65-200 Ø180	10,8	10,7	10,7	10,4	9,5	8,5	7,8	-	-	-	-
ENR 65-200 Ø190	12,1	12,1	12	11,7	11	10,4	9,7	8,8	-	-	-
ENR 65-200 Ø200	13,5	13,5	13,4	13	12,8	12	11,3	10,7	9,9	-	-
ENR 65-200 Ø207	14,8	14,8	14,7	14,4	14	13,4	12,8	12	11,2	10,5	-
ENR 65-200 Ø214	15,9	15,9	15,9	15,8	15,4	14,9	14	13,5	12,7	12	11,4

207

SELECTION CHART

50Hz

Rev. 0

65 – 250 Version

Pump type ENR 4 Three Phase	Q=Capacity									
	m ³ /h 0	10	20	30	40	62,5	65	69	72	76
	l/min 0	167	333	500	667	1042	1083	1150	1200	1267
	H=Total manometric head in meters									
ENR 65-250 Ø215	14,2	14,1	14	13,9	13	10,4	-	-	-	-
ENR 65-250 Ø225	16	16	16	15,9	15	12,5	12	-	-	-
ENR 65-250 Ø235	18	18	18	17,8	17,2	14,8	14	13	-	-
ENR 65-250 Ø245	20	20	20	19,9	19,2	17	16,4	15,6	15	-
ENR 65-250 Ø255	22,2	22,1	22,1	22	21,9	19,5	18,9	18	17,4	16,2

65 – 315 Version

Pump type ENR 4 Three Phase	Q=Capacity									
	m ³ /h 0	20	30	50	70	79	85	90	95	100
	l/min 0	333	500	833	1167	1317	1417	1500	1583	1667
	H=Total manometric head in meters									
ENR 65-315 Ø285	26,4	26,2	26	24	18,7	15,9	-	-	-	-
ENR 65-315 Ø295	29	28,8	28,4	26,4	22	18,4	16,4	-	-	-
ENR 65-315 Ø305	31,8	31,7	31,3	28,8	24,9	22	20	18	-	-
ENR 65-315 Ø315	34	34	33,9	32	28	25,6	23,7	21,8	19	-
ENR 65-315 Ø325	36,4	36,3	36,2	34,7	31	28,6	26,5	25	22,4	20

80 – 160 Version

Pump type ENR 4 Three Phase	Q=Capacity										
	m ³ /h 0	20	30	40	60	70	76	83	90	96	105
	l/min 0	333	500	667	1000	1167	1267	1383	1500	1600	1750
	H=Total manometric head in meters										
ENR 80-160 Ø130	5,1	5	4,9	4,5	3,5	2,9	-	-	-	-	-
ENR 80-160 Ø140	6	6	5,9	5,7	4,9	4	3,5	-	-	-	-
ENR 80-160 Ø150	7,1	7,05	7	6,9	6,1	5,5	5,1	4,5	-	-	-
ENR 80-160 Ø160	8,2	8,2	8,2	8,1	7,7	7,1	6,8	6,1	5,5	-	-
ENR 80-160 Ø168	9,7	9,8	9,7	9,5	9	8,7	8,3	7,9	7,1	6,5	-
ENR 80-160 Ø175	11	11	10,9	10,9	10,4	10	9,8	9,2	8,9	8	7,4

SELECTION CHART

50Hz

Rev. 0

80 – 200 Version

Pump type ENR 4 Three Phase	Q=Capacity											
	m ³ /h 0	20	30	40	60	70	76	82,5	89	95	102	110
	l/min 0	333	500	667	1000	1167	1267	1375	1483	1583	1700	1833
H=Total manometric head in meters												
ENR 80-200 Ø170	9	8,9	8,8	8,2	7	5,8	5	-	-	-	-	-
ENR 80-200 Ø180	10,3	10,2	10,1	9,9	8,9	7,9	7	6,2	-	-	-	-
ENR 80-200 Ø190	11,8	11,8	11,6	11,2	10,2	9,5	8,9	8,1	7,1	-	-	-
ENR 80-200 Ø200	13,4	13,4	13,2	13,1	12,1	11,7	11	10,5	9,9	9	-	-
ENR 80-200 Ø207	14,9	14,9	14,8	14,7	14	13,3	13	12,4	11,9	11	10,2	-
ENR 80-200 Ø214	16,2	16,1	16,1	16	15,5	15	14,8	14,2	13,9	13,1	12,4	11,5

80 – 250 Version

Pump type ENR 4 Three Phase	Q=Capacity										
	m ³ /h 0	20	40	60	80	90	94	99	105	110	
	l/min 0	333	667	1000	1333	1500	1567	1650	1750	1833	
H=Total manometric head in meters											
ENR 80-250 Ø215	14	14	13,9	13	10,9	9	-	-	-	-	
ENR 80-250 Ø225	16	16	15,9	15	13	11,4	10,8	-	-	-	
ENR 80-250 Ø235	18	18	17,9	17	15	13,5	12,9	11,9	-	-	
ENR 80-250 Ø245	20,1	20,1	20	19,5	17,8	16,4	15,4	14,5	13,5	-	
ENR 80-250 Ø255	22,7	22,7	22,5	22	20,2	19	18,2	17,4	16,4	15	

80 – 315 Version

Pump type ENR 4 Three Phase	Q=Capacity											
	m ³ /h 0	20	30	50	60	80	110	120	125	130	135	140
	l/min 0	333	500	833	1000	1333	1833	2000	2083	2167	2250	2333
H=Total manometric head in meters												
ENR 80-315 Ø285	27	26,8	26,4	25,8	24,8	22	15	12	-	-	-	-
ENR 80-315 Ø295	29	29	28,8	28	27,7	24,9	18,4	16	14	-	-	-
ENR 80-315 Ø305	31,9	31,8	31,7	30,7	30	28	21,8	18,2	17	15	-	-
ENR 80-315 Ø315	34	33,9	33,8	33	32,4	30,9	24,9	22	20,5	19	17	-
ENR 80-315 Ø325	36,1	36	36	35,8	35	33,8	28	26	24	23	21	19,5

SELECTION CHART

50Hz

Rev. 0

80 – 400 Version

Pump type ENR 4 Three Phase	Q=Capacity										
	m ³ /h 0	20	40	60	80	90	97	104	110	115	120
	l/min 0	333	667	1000	1333	1500	1617	1733	1833	1917	2000
	H=Total manometric head in meters										
ENR 80-400 Ø335	38,8	38,7	38,5	37	32	28	-	-	-	-	-
ENR 80-400 Ø350	42,5	42,5	42,5	42	38	34	30	-	-	-	-
ENR 80-400 Ø365	47,5	47,5	46,5	46	42	39	36	32	-	-	-
ENR 80-400 Ø380	51,5	51,5	51	50	47	44	40	37,8	34	-	-
ENR 80-400 Ø395	56	56	56	54,5	52	50	46	43	38,1	35,9	-
ENR 80-400 Ø409	60	60	60	59	56	54	52	48	44	41	36

100 – 160 Version

Pump type ENR 4 Three Phase	Q=Capacity											
	m ³ /h 0	20	40	60	100	140	151	160	171	189	202	
	l/min 0	333,3	667	1000	1667	2333	2517	2667	2850	3150	3367	
	H=Total manometric head in meters											
ENR 100-160 Ø183(Ø183)	5,9	6	6	5,8	5	3,5	3	-	-	-	-	
ENR 100-160 Ø183(Ø173)/Ø183(Ø167) - 5°	6,5	6,7	6,7	6,5	5,9	4,5	3,8	3,4	-	-	-	
ENR 100-160 Ø183(Ø165)/Ø183(Ø155) - 7.7°	7,7	7,9	7,9	7,8	7	5,8	5	4,8	4	-	-	
ENR 100-160 Ø183(Ø158)/Ø183(Ø142) - 11.5°	8,7	8,9	8,9	8,9	8,5	7,4	6,9	6,5	6	5	-	
ENR 100-160 Ø183(Ø151)/Ø183(Ø129) - 14.7°	10,1	10,1	10,2	10,3	10,1	9,3	8,9	8,6	8	7,1	6	

100 – 200 Version

Pump type ENR 4 Three Phase	Q=Capacity										
	m ³ /h 0	20	40	60	80	100	119	130	142	155	172
	l/min 0	333	667	1000	1333	1667	1983	2167	2367	2583	2867
	H=Total manometric head in meters										
ENR 100-200 Ø170	8,2	8	7,9	7,1	6,2	5	3,1	-	-	-	-
ENR 100-200 Ø180	9,5	9,5	9,2	9	8,1	7	5,5	4,7	-	-	-
ENR 100-200 Ø190	11	11	10,9	10,5	10	9	7,8	7	6	-	-
ENR 100-200 Ø200	12,5	12,6	12,5	12,2	12	11,1	10	9,5	8,5	7,2	-
ENR 100-200 Ø213	14,5	14,5	14,3	14,2	14	13,5	12,8	12	11,5	10,2	9

210

SELECTION CHART

50Hz

Rev. 0

100 – 250 Version

Pump type ENR 4 Three Phase	Q=Capacity										
	m ³ /h 0	40	60	80	100	120	139	150	161	175	190
	l/min 0	667	1000	1333	1667	2000	2317	2500	2683	2917	3167
	H=Total manometric head in meters										
ENR 100-250 Ø215	14,1	14	13,8	13	11,9	10	8,2	-	-	-	-
ENR 100-250 Ø225	16,1	16	15,9	15	14	12,7	11	9,9	-	-	-
ENR 100-250 Ø235	18	18	17,9	17	16	15	13,2	12	10,9	-	-
ENR 100-250 Ø245	20,1	20	20	19,5	18,8	17,8	16,1	15	13,9	12	-
ENR 100-250 Ø255	22,2	22,2	22	21,9	21	20,1	19	18	17	15,5	13,8

100 – 315 Version

Pump type ENR 4 Three Phase	Q=Capacity											
	m ³ /h 0	20	40	80	100	140	160	180	190	200	210	222
	l/min 0	333	667	1333	1667	2333	2667	3000	3167	3333	3500	3700
	H=Total manometric head in meters											
ENR 100-315 Ø285	27,4	27,3	27,2	26	25	20,5	17,5	13	-	-	-	-
ENR 100-315 Ø295	28	28	27,5	27,7	27,5	23	20,5	17	15	-	-	-
ENR 100-315 Ø305	31,5	31,4	31,5	30,5	30	25,5	23	20	18	16,5	-	-
ENR 100-315 Ø315	34	34	34	33	32,5	28	26	23	21,5	19,5	17,5	-
ENR 100-315 Ø325	36,5	36,4	36,6	35	34	31,5	28	26	24	23	21,5	19

100 – 400 Version

Pump type ENR 4 Three Phase	Q=Capacity										
	m ³ /h 0	40	60	100	120	150	160	170	180	192	204
	l/min 0	667	1000	1667	2000	2500	2667	2833	3000	3200	3400
	H=Total manometric head in meters										
ENR 100-400 Ø335	38	37,9	37	34	31	23	-	-	-	-	-
ENR 100-400 Ø350	42	42	42	38,8	36	28	25,9	-	-	-	-
ENR 100-400 Ø365	46	46	46	43	40,5	34	31	28	-	-	-
ENR 100-400 Ø380	50	50	50	48	46	40	38	34,5	32	-	-
ENR 100-400 Ø395	54	54	54	50	50	46	44	42	39	36	-
ENR 100-400 Ø409	59	59	58,5	56	56	52	50	48	46	42	39

211

SELECTION CHART

50Hz

Rev. 0

125 – 200 Version

Pump type ENR 4 Three Phase	Q=Capacity										
	m ³ /h 0	50	100	150	200	250	275	290	313	335	350
	l/min 0	833	1667	2500	3333	4167	4583	4833	5208	5583	5833
H=Total manometric head in meters											
ENR 125-200 Ø180	10,9	10,9	10,6	10	8,8	6,3	5,1	-	-	-	-
ENR 125-200 Ø190	11,9	11,9	11,8	11,4	10,3	8,5	7,2	6	-	-	-
ENR 125-200 Ø200	13,1	13	13	12,8	12	10,2	9,2	8,1	7	-	-
ENR 125-200 Ø210	14,5	14,4	14,4	14,1	13,5	12	11,1	10,1	9	7,9	-
ENR 125-200 Ø220	16	15,9	15,9	15,7	15	13,9	13	12	11	10	8,8

125 – 250 Version

Pump type ENR 4 Three Phase	Q=Capacity										
	m ³ /h 0	40	80	120	160	200	225	250	270	290	310
	l/min 0	667	1333	2000	2667	3333	3750	4167	4500	4833	5167
H=Total manometric head in meters											
ENR 125-250 Ø215	14,9	14,9	14,5	14	12,8	10	8	-	-	-	-
ENR 125-250 Ø225	16,6	16,6	16,5	16	15	13	11,2	9,2	-	-	-
ENR 125-250 Ø235	18,5	18,5	18,3	18	17	15,5	14	12,8	11	-	-
ENR 125-250 Ø245	20,5	20,5	20,3	20	19,1	18	16,9	15,7	14	12,5	-
ENR 125-250 Ø255	22,5	22,5	22,2	22	21,2	20,2	19,1	17,7	17	15,8	14,2

125 – 315 Version

Pump type ENR 4 Three Phase	Q=Capacity										
	m ³ /h 0	40	80	120	160	200	250	270	290	315	340
	l/min 0	667	1333	2000	2667	3333	4167	4500	4833	5250	5667
H=Total manometric head in meters											
ENR 125-315 Ø270	25	25	25	24,9	23	21	15,5	-	-	-	-
ENR 125-315 Ø285	27,5	27,5	27,5	27,4	26	24,5	20	17,5	-	-	-
ENR 125-315 Ø300	31,5	31,5	31	31	30	28	24,5	22	18,5	-	-
ENR 125-315 Ø315	34	34	34	33,5	33	32	28,5	26	23	20	-
ENR 125-315 Ø329	37,5	37,5	38	37,9	37	35,5	32,5	31	28,5	25,5	22

SELECTION CHART

50Hz

Rev. 0

125 – 400 Version

Pump type ENR 4 Three Phase	Q=Capacity										
	m ³ /h 0	50	100	150	200	240	260	285	300	325	350
	l/min 0	833	1667	2500	3333	4000	4333	4750	5000	5417	5833
	H=Total manometric head in meters										
ENR 125-400 Ø335	37,9	37,8	36,4	34,8	30	24	-	-	-	-	-
ENR 125-400 Ø350	42	42	40,5	38,4	35	30	26	-	-	-	-
ENR 125-400 Ø365	46	46	45	43	40	35	32	29	-	-	-
ENR 125-400 Ø380	50	50	49	48	44	40	37,8	34	31,6	-	-
ENR 125-400 Ø395	54	54	54	52	50	46	44	41	38	34	-
ENR 125-400 Ø409	58	58	58	57	55	52	50	47	45	41,5	37

150 – 200 Version

Pump type ENR 4 Three Phase	Q=Capacity										
	m ³ /h 0	50	100	150	200	250	360	385	410	440	470
	l/min 0	833	1667	2500	3333	4167	6000	6417	6833	7333	7833
	H=Total manometric head in meters										
ENR 150-200 Ø160	7,8	7,8	7,8	7,7	7,4	7	5	-	-	-	-
ENR 150-200 Ø175	9	9	9	8,9	8,8	8,4	6,4	5,8	-	-	-
ENR 150-200 Ø190	10,5	10,4	10,5	10,5	10,4	10	8,3	7,6	6,9	-	-
ENR 150-200 Ø205	12,5	12,4	12,5	12,5	12,3	12	11	10	9,2	8	-
ENR 150-200 Ø220	14,5	14,4	14,5	14,4	14,3	14,1	13	12	11,4	10	9,1

150 – 250 Version

Pump type ENR 4 Three Phase	Q=Capacity										
	m ³ /h 0	50	150	250	300	350	412	438	475	509	512
	l/min 0	833	2500	4167	5000	5833	6867	7300	7917	8483	8533
	H=Total manometric head in meters										
ENR 150-250 Ø215	15	15	14,9	14	13,5	12,5	10,5	-	-	-	-
ENR 150-250 Ø225	16,8	16,8	16,7	16,1	15,5	14,5	13	11,9	-	-	-
ENR 150-250 Ø235	18,8	18,8	18,6	18,2	17,8	17	15,3	14,2	13	-	-
ENR 150-250 Ø245	20,5	20,4	20,5	20	19,8	19	17,5	16,5	15,2	14,7	-
ENR 150-250 Ø258	22,2	22,1	22,1	21,9	21,5	20,8	19,5	18,4	17,2	16,5	16

SELECTION CHART

50Hz

Rev. 0

150 – 315 Version

Pump type ENR 4 Three Phase	Q=Capacity								
	m ³ /h 0	100	200	300	365	400	425	460	490
	l/min 0	1666	3333	5000	6083	6667	7083	7667	8167
H=Total manometric head in meters									
ENR 150-315 Ø270	23,7	23,7	23,5	21,5	17,5	-	-	-	-
ENR 150-315 Ø285	26,5	26,5	26,4	25	21,5	20	-	-	-
ENR 150-315 Ø300	30	30	29,9	28	25,5	23,8	22,5	-	-
ENR 150-315 Ø315	33	33	33	31	29	27,5	26,5	25	-
ENR 150-315 Ø329	37	37	36,5	35	33	32	30,5	29	27

150 – 400 Version

Pump type ENR 4 Three Phase	Q=Capacity									
	m ³ /h 0	100	200	300	400	430	460	490	510	540
	l/min 0	1666	3333	5000	6667	7167	7667	8167	8500	9000
H=Total manometric head in meters										
ENR 150-400 Ø335	36,3	36,3	36	33,9	27	-	-	-	-	-
ENR 150-400 Ø350	40	40	39,9	37	31	29	-	-	-	-
ENR 150-400 Ø365	44	44	44	42	36	33	30	-	-	-
ENR 150-400 Ø380	48	48	48	45,5	40	38	35	32	-	-
ENR 150-400 Ø395	52	52	52	50	45	43	40	38	34	-
ENR 150-400 Ø409	57,5	56,5	56	54	50	48	46	44	40	38

150 – 500 Version

Pump type ENR 4 Three Phase	Q=Capacity							
	m ³ /h 0	100	150	200	300	360	410	460
	l/min 0	1666	2500	3333	5000	6000	6833	7667
H=Total manometric head in meters								
ENR 150-500 Ø420	65	64	62,5	60	47	-	-	-
ENR 150-500 Ø450	74	73	72,5	70	62	51	-	-
ENR 150-500 Ø480	85	84	83,5	81,5	75	67	58	-
ENR 150-500 Ø514	96	96	95	95	90	84	77	68

SELECTION CHART

50Hz

Rev. 0

200 – 250 Version

Pump type ENR 4 Three Phase	Q=Capacity									
	m ³ /h 0	200	300	400	500	600	640	680	725	760
	l/min 0	3333	5000	6667	8333	10000	10667	11333	12083	12667
H=Total manometric head in meters										
ENR 200-250 Ø256(256)/236(236)-9°	8,5	8,2	7,8	6,8	5,3	3,5	-	-	-	-
ENR 200-250 Ø256(244)/236(209)-15°	11	10,6	10	9,3	8	6	5,5	-	-	-
ENR 200-250 Ø256(232)/236(184)-20°	13,1	12,9	12,3	11,5	10,3	8,7	7,8	7	-	-
ENR 200-250 Ø256(220)/236(157)-24.5°	15,6	15,2	14,9	14	13	11	10,3	9,4	8	-
ENR 200-250 Ø256(214)/236(125)-35.5°	18	17,8	17,2	16,5	15,3	14	13	12	11	10,3

200 – 315 Version

Pump type ENR 4 Three Phase	Q=Capacity								
	m ³ /h 0	200	300	400	500	560	650	750	800
	l/min 0	3333	5000	6667	8333	9333	10833	12500	13333
H=Total manometric head in meters									
ENR 200-315 /D2voll= Ø329	21,8	21,8	20,5	18,4	14	10	-	-	-
ENR 200-315 Ø329(Ø312)/ Ø329(Ø300)-7.5°	25,9	25,9	25	24	21	18	13,8	-	-
ENR 200-315 Ø329(Ø297)/ Ø329(Ø269)-15.1°	30	30	30	28,9	28	26	22	16	-
ENR 200-315 Ø329(Ø282)/ Ø329(Ø238)-22.8°	35	35,3	35,2	34,5	33	32	28,9	25	23

200 – 400 Version

Pump type ENR 4 Three Phase	Q=Capacity										
	m ³ /h 0	200	300	400	500	600	650	705	755	800	840
	l/min 0	3333	5000	6667	8333	10000	10833	11750	12583	13333	14000
H=Total manometric head in meters											
ENR 200-400 Ø335	36,5	36,5	36	34,2	30,7	25	-	-	-	-	-
ENR 200-400 Ø350	42	42	42	40	36,5	31	28	-	-	-	-
ENR 200-400 Ø365	46	46	46	44	42	37	34	30	-	-	-
ENR 200-400 Ø380	50,5	50,5	50	49,5	47	43	40	37	33	-	-
ENR 200-400 Ø395	56	56	55	54	52	49	46	44	40	36,8	-
ENR 200-400 Ø409	60,5	60	60	59	57	54	52	49	46	43	40

215

SELECTION CHART

50Hz

Rev. 0

200 – 500 Version

Pump type ENR 4 Three Phase	Q=Capacity									
	m ³ /h 0	100	200	300	400	500	600	690	790	900
	l/min 0	1667	3333	5000	6667	8333	10000	11500	13167	15000
H=Total manometric head in meters										
ENR 200-500 Ø420	64,5	64,5	64	63	59	54	45	-	-	-
ENR 200-500 Ø450	73	73	73	72	70	66	60	50	-	-
ENR 200-500 Ø480	83	84	84	83	80	78	73	67	59	-
ENR 200-500 Ø514	95	95	95	95	94	92	88	84	77	68

250 – 300 Version

Pump type ENR 4 Three Phase	Q=Capacity										
	m ³ /h 0	100	200	300	400	500	600	770	910	1010	1110
	l/min 0	1666	3333	5000	6667	8333	10000	12833	15167	16833	18500
H=Total manometric head in meters											
ENR 250-300 Ø306(Ø306)/Ø294(Ø294)-5.5°	18,2	18	17,8	17,2	16,8	15,9	14	9,4	-	-	-
ENR 250-300 Ø306(Ø295)/Ø294(Ø275)-8.5°	21,2	21	20,9	20,4	20	19	18	14,7	10,5	-	-
ENR 250-300 Ø306(Ø283)/Ø294(Ø251)-12.5°	24	24	23,9	23,5	23	22,5	21,5	18,9	16	12	-
ENR 250-300 Ø306(Ø272)/Ø294(Ø226)-17°	27	27	26,9	26,4	26	25,8	25	22,8	20,4	17,9	14,9

250 – 315 Version

Pump type ENR 4 Three Phase	Q=Capacity								
	m ³ /h 0	200	400	500	600	700	810	990	1120
	l/min 0	3333	6667	8333	10000	11667	13500	16500	18667
H=Total manometric head in meters									
ENR 250-315 Ø329(329)/329(316)-5.7°	25	25	24,4	23,8	22	20	17,9	-	-
ENR 250-315 Ø329(316)/329(293)-9.6°	30	29,9	28,8	28	27	25,9	24	20	-
ENR 250-315 Ø329(280)/329(270)-3.5°	34	34	33,9	33	32,4	31,6	29,9	26,4	23

250 – 400 Version

Pump type ENR 4 Three Phase	Q=Capacity								
	m ³ /h 0	200	400	600	700	760	890	1080	1210
	l/min 0	3333	6667	10000	11667	12667	14833	18000	20167
H=Total manometric head in meters									
ENR 250-400 Ø320	35,5	35	32	25	20	17	-	-	-
ENR 250-400 Ø350	43	42	40	35	32	28	20	-	-
ENR 250-400 Ø380	50	49	47	45	42	40	35	25	-
ENR 250-400 Ø409	58	57	55	52,5	51	49	45	37	30

SELECTION CHART

50Hz

Rev. 0

250 – 500 Version

Pump type ENR 4 Three Phase	Q=Capacity							
	m ³ /h 0	200	400	600	700	790	990	1190
	l/min 0	3333	6666	10000	11667	13167	16500	19833
H=Total manometric head in meters								
ENR 250-500 Ø445(Ø424)/ Ø445(Ø412)-8°	65	65	61,5	55	51,5	47	-	-
ENR 250-500 Ø466	80	80	78	75	71	68	58	-
ENR 250-500 Ø514	97	97	96	94	91	89	82	71

300 – 400 Version

Pump type ENR 4 Three Phase	Q=Capacity								
	m ³ /h 0	200	400	600	800	1000	1200	1420	1700
	l/min 0	3333,3	6667	10000	13333	16667	20000	23667	28333
H=Total manometric head in meters									
ENR 300-400 Ø320	34	33,5	32	29	24,9	15	-	-	-
ENR 300-400 Ø350	41,5	40	39	37	34	26,5	18	-	-
ENR 300-400 Ø380	48	47	46	46	44	40	32	21	-
ENR 300-400 Ø409	56	55	55	54	52	48	44	36	25

300 – 500 Version

Pump type ENR 4 Three Phase	Q=Capacity										
	m ³ /h 0	200	400	600	800	1000	1200	1400	1600	1780	2000
	l/min 0	3333	6667	10000	13333	16667	20000	23333	26667	29667	33333
H=Total manometric head in meters											
ENR 300-500 Ø420	64	64	64	62	61	60	55	50	-	-	-
ENR 300-500 Ø450	73	72	72	72	71	70	68	65	60	-	-
ENR 300-500 Ø480	83	83	82	82	81,5	80,5	79	75	71	68	-
ENR 300-500 Ø514	95	95	95	95	95	95	93	90	87	85	78

TYPE KEY AND CURVE SPECIFICATIONS

50Hz

Rev. 0

TYPE KEY:

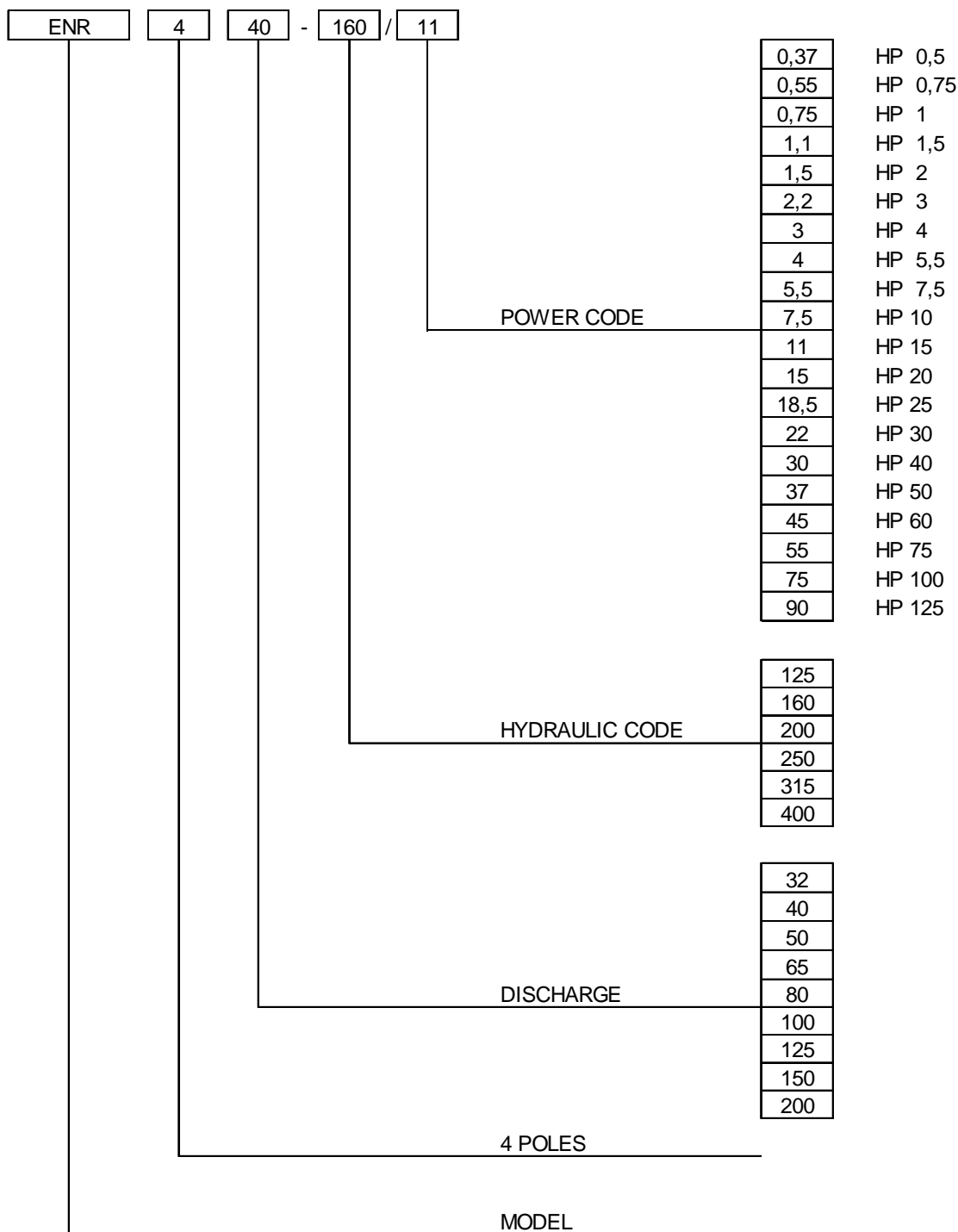

PERFORMANCE CURVE SPECIFICATIONS

The specifications below qualify the curves shown on the following pages.

Tolerances according to ISO 9906 Annex A

The curves refer to effective speed of asynchronous motors at 50 Hz

Measurements were carried out with clean water at 20°C of temperature and with a kinematic viscosity of $\nu = 1 \text{ mm}^2/\text{s}$ (1 cSt)

The NPSH curve is an average curve obtained in the same conditions of performance curves.

The continuous curves indicate the recommended working range. The dotted curve is only a guide.

In order to avoid the risk of over-heating, the pumps should not be used at a flow rate below 10% of best efficiency point.

Symbols explanation:

- Q = volume flow rate
- H = total head
- P_2 = pump power input (shaft power)
- η = pump efficiency
- NPSH = net positive suction head required by the pump
- MEI = minimum efficiency index

The minimum efficiency index (MEI) is a measure of the quality of a pump size in respect to its mean efficiency. The minimum efficiency index is based on the hydraulic efficiency and on the head at the best efficiency point.

The efficiency of a pump with trimmed impeller is usually lower than that of a pump with the full impeller diameter. The trimming of the impeller will adapt the pump to a fixed duty point, leading to reduced energy consumption. The minimum efficiency index (MEI) is based on the full impeller diameter.

The operation of these water pumps with variable duty points may be more efficient and economic when controlled, for example, by the use of a variable speed drive that matches the pump duty to the system.

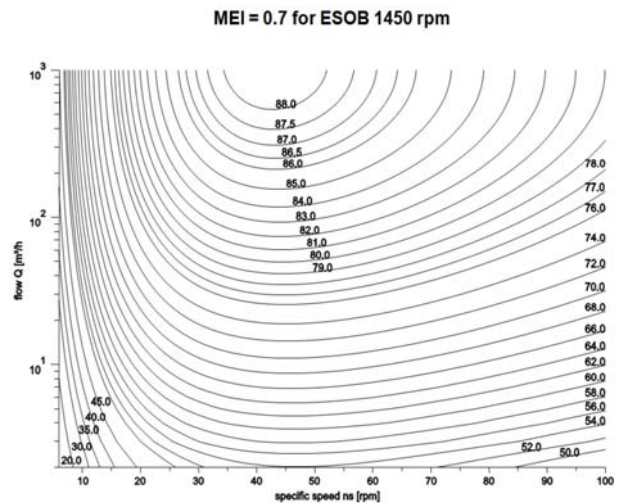
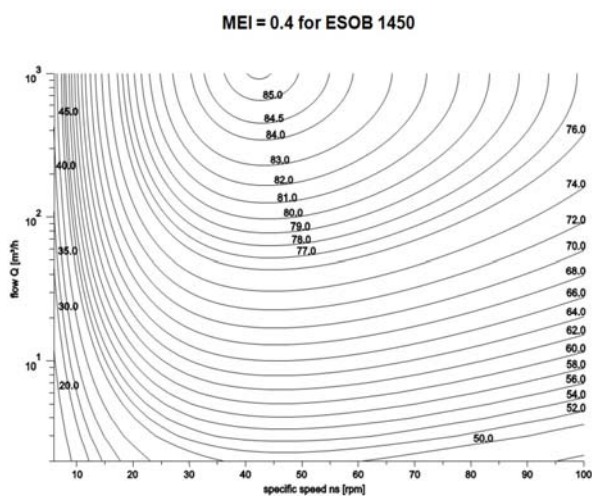

ENR4 32-125 MEI > 0.40

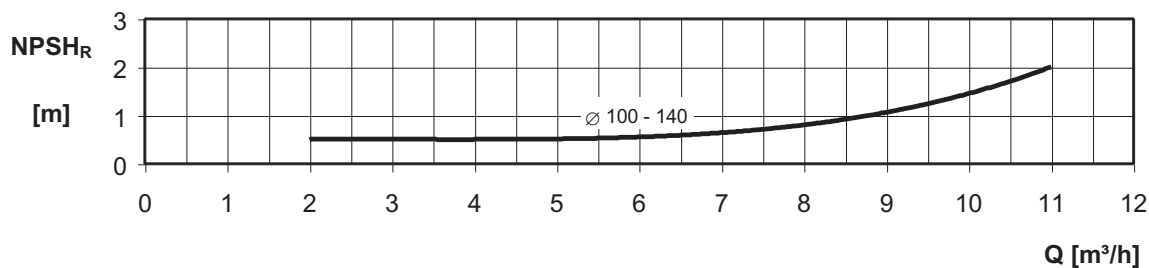
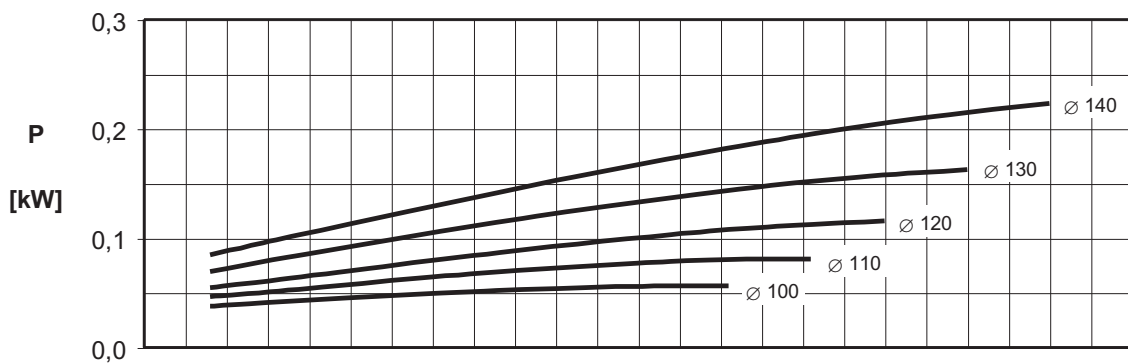
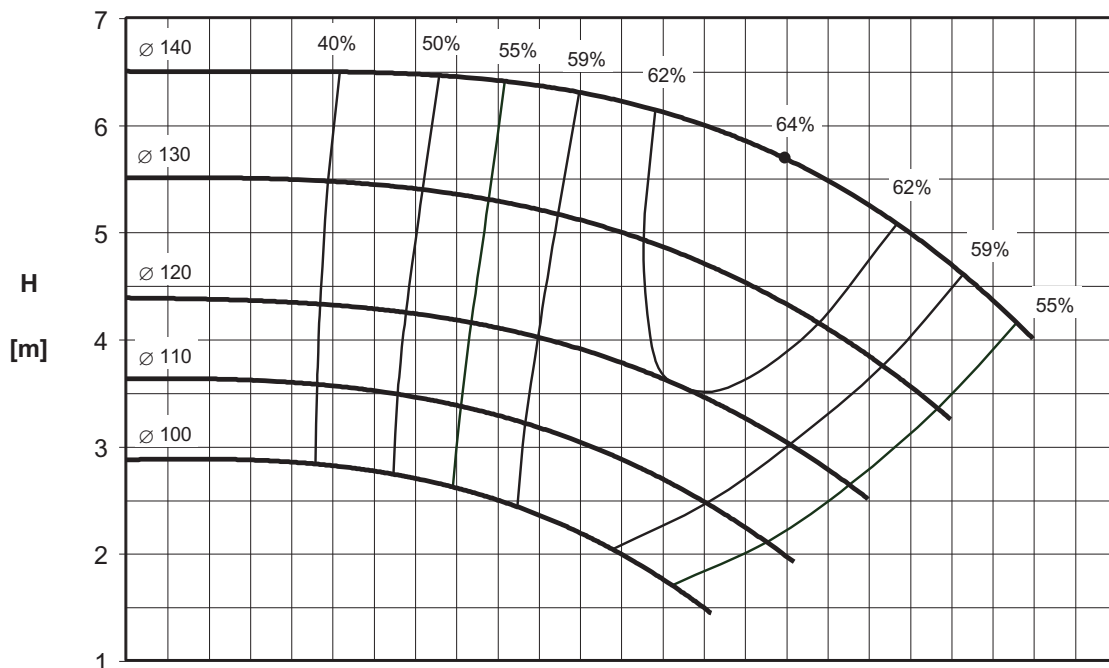

Rotation speed $\approx 1450 \text{ min}^{-1}$
Test standard: ISO 9906 – Annex A

ENR4 32-160A MEI > 0.40

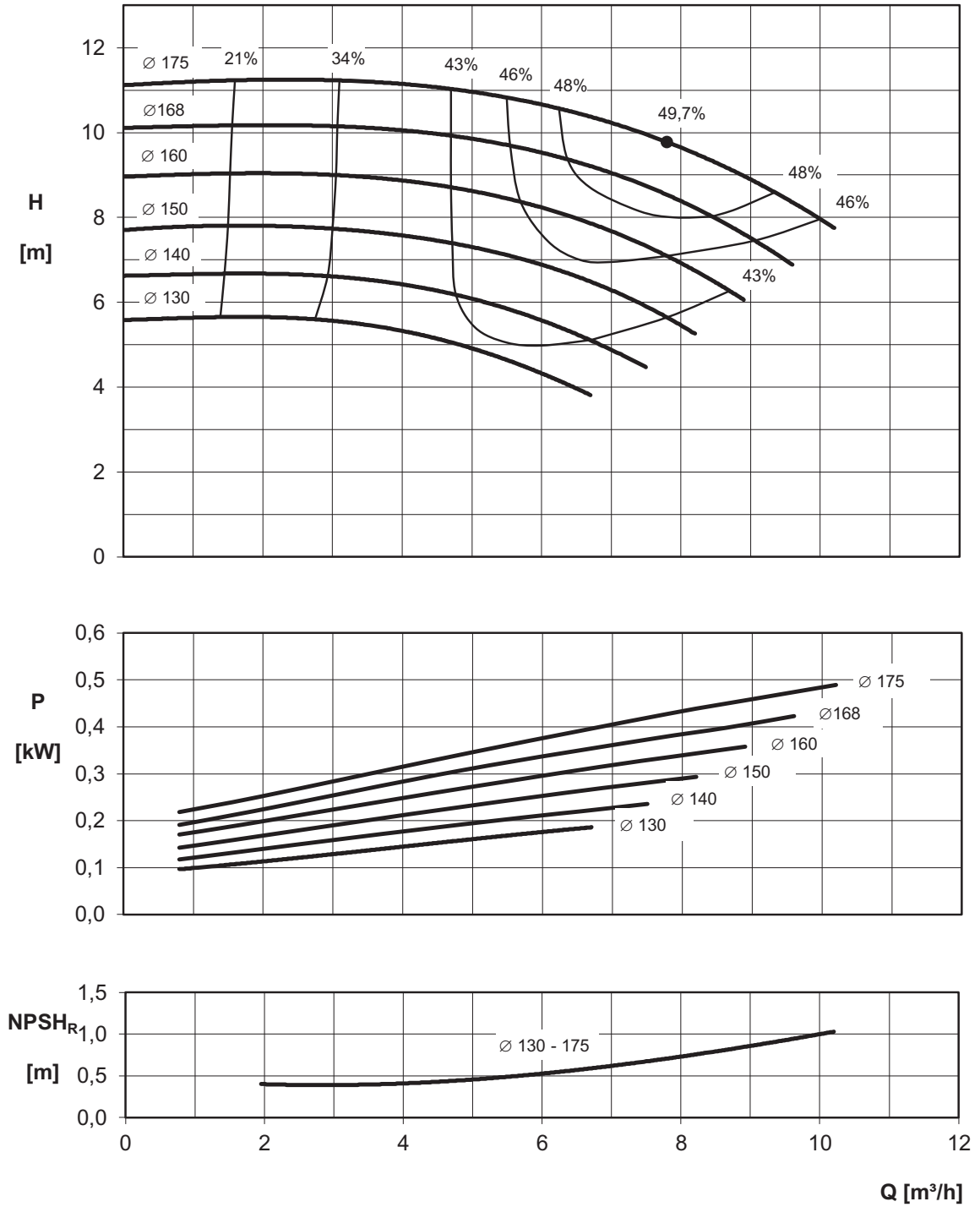

Rotation speed $\approx 1450 \text{ min}^{-1}$
Test standard: ISO 9906 – Annex A

ENR4 32-160B MEI > 0.40

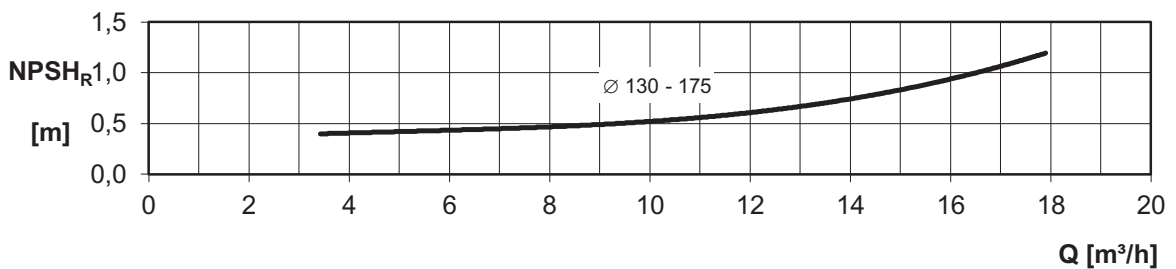
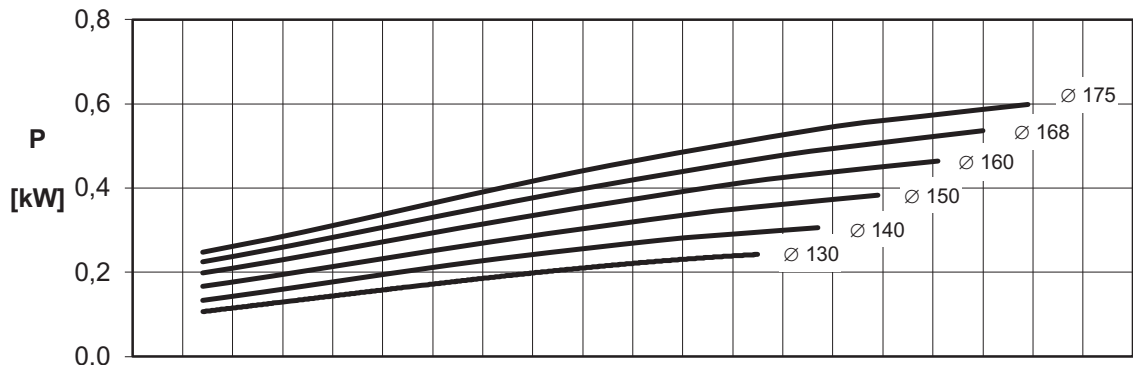
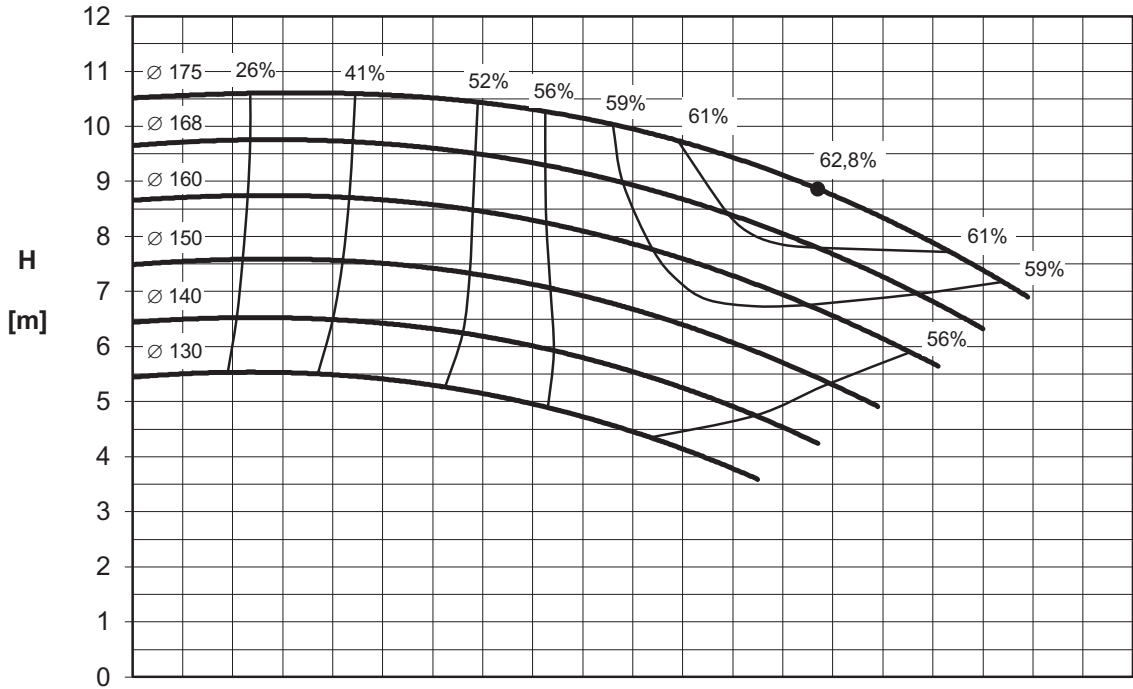

Rotation speed $\approx 1450 \text{ min}^{-1}$
Test standard: ISO 9906 – Annex A

ENR4 32-200A MEI > 0.40

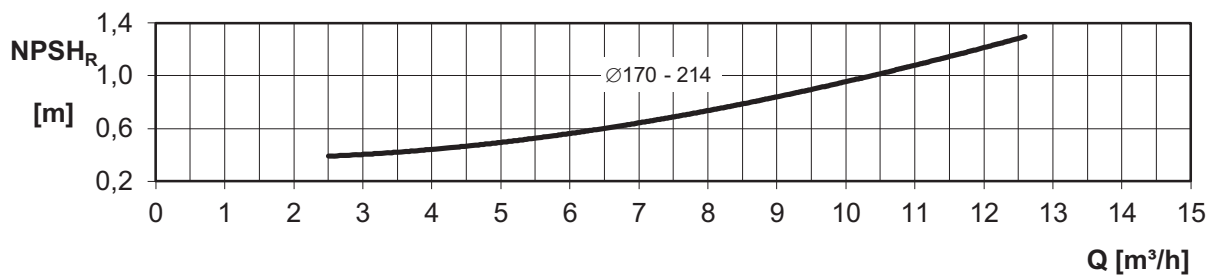
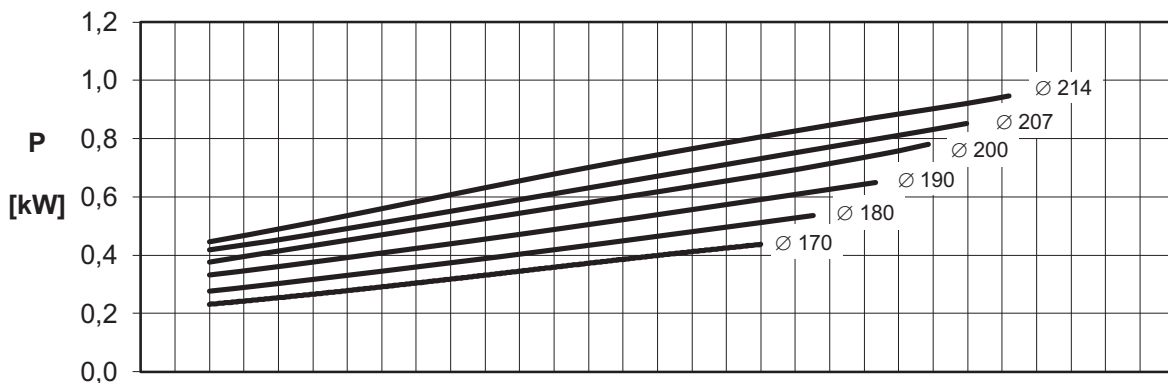
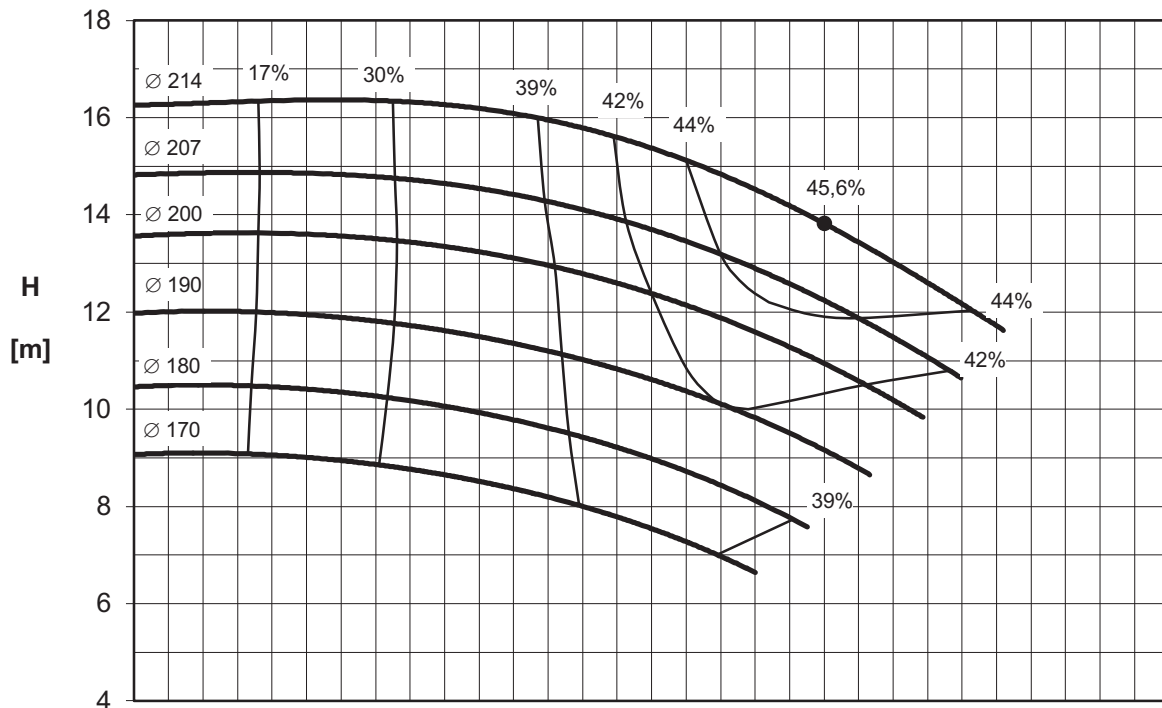

Rotation speed $\approx 1450 \text{ min}^{-1}$
Test standard: ISO 9906 – Annex A

ENR4 32-200B MEI > 0.40

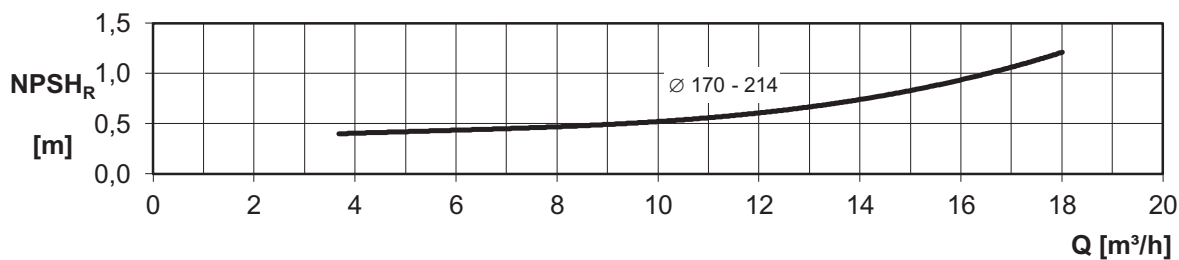
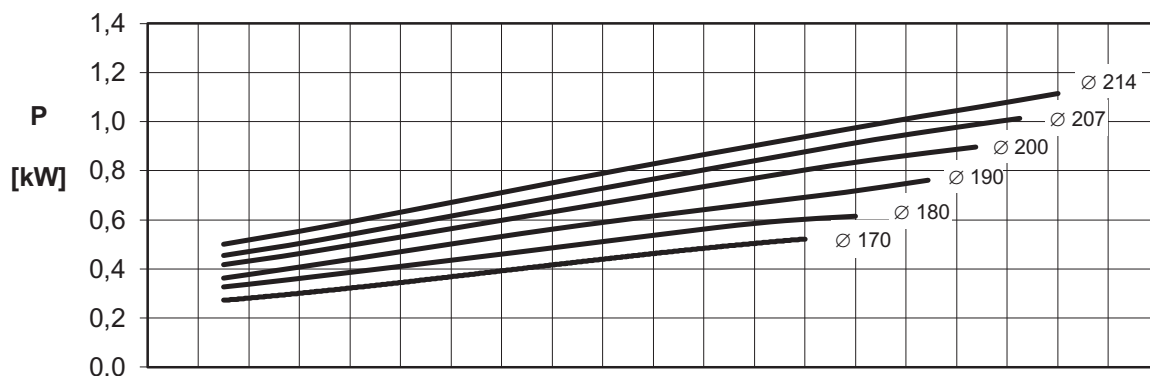
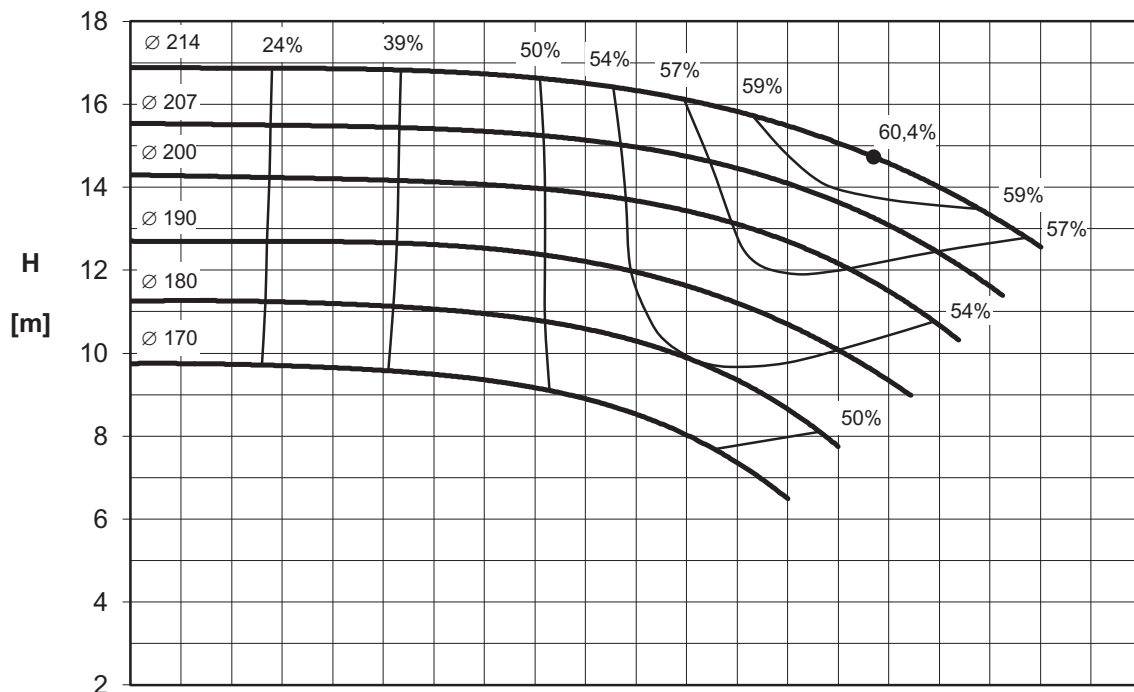

Rotation speed $\approx 1450 \text{ min}^{-1}$
Test standard: ISO 9906 – Annex A

ENR4 32-250 MEI > 0.40

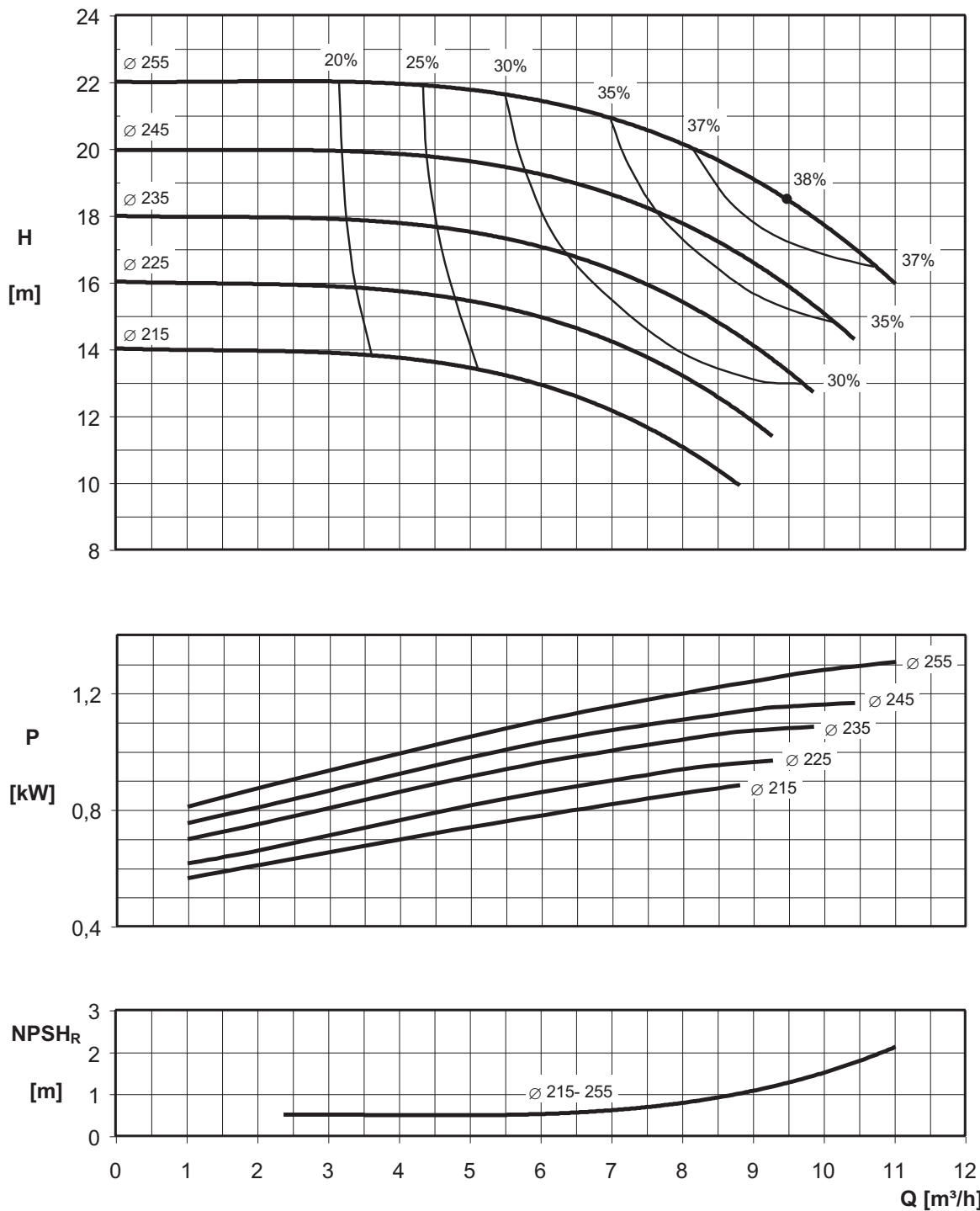

Rotation speed $\approx 1450 \text{ min}^{-1}$
Test standard: ISO 9906 – Annex A

ENR4 40-125 MEI > 0.40

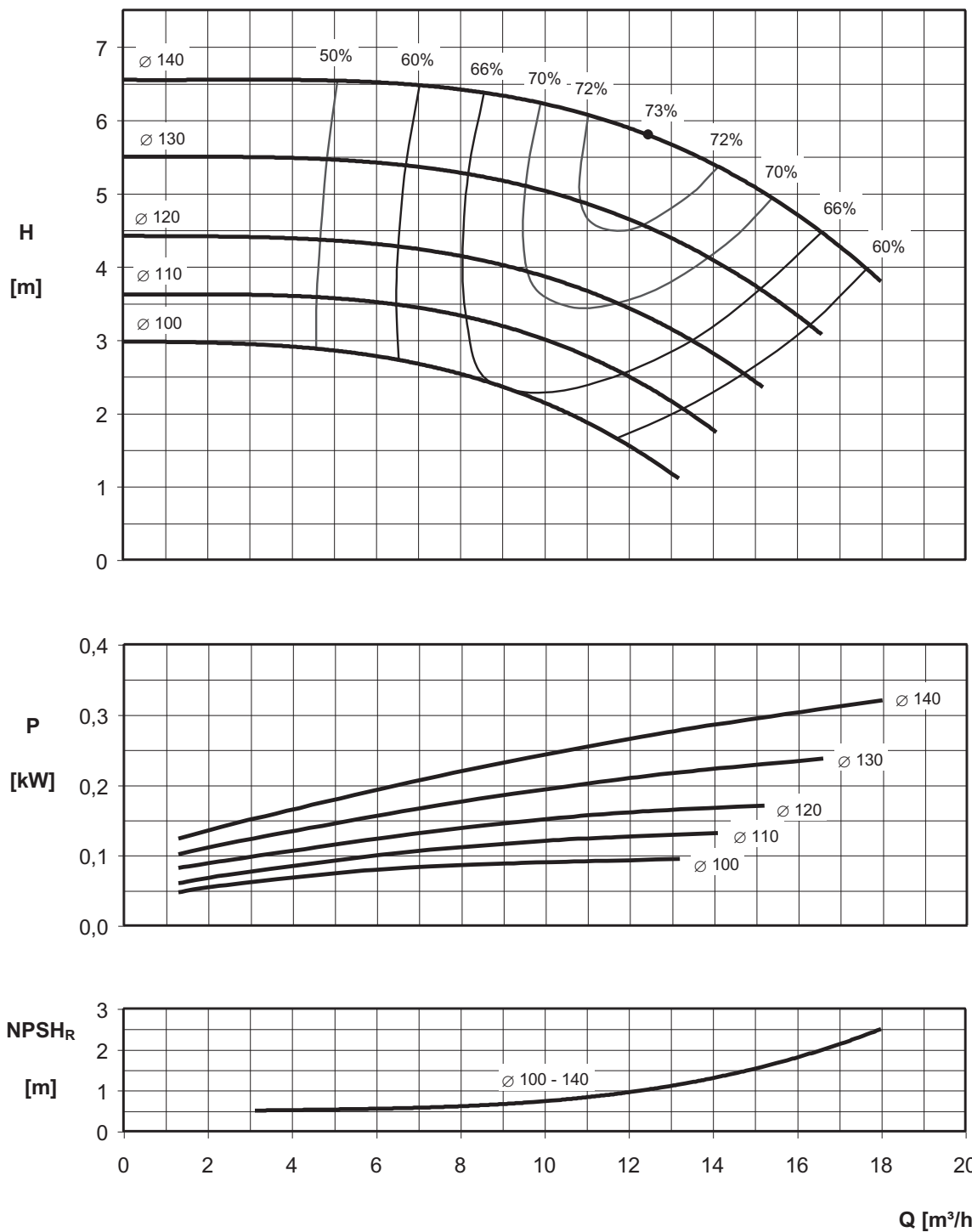

Rotation speed $\approx 2900 \text{ min}^{-1}$
Test standard: ISO 9906 – Annex A

ENR4 40-160 MEI > 0.40

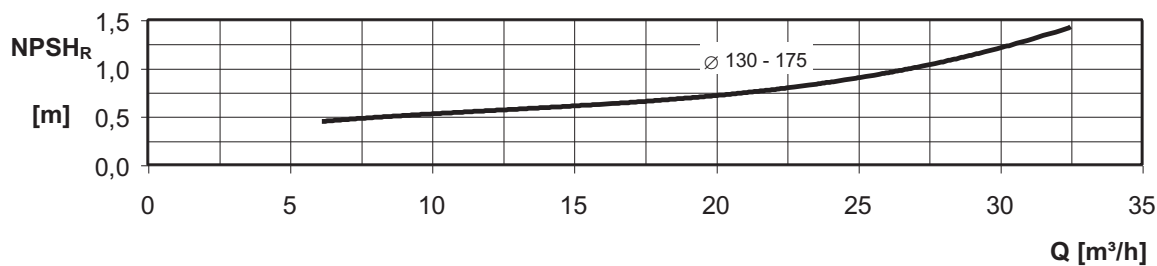
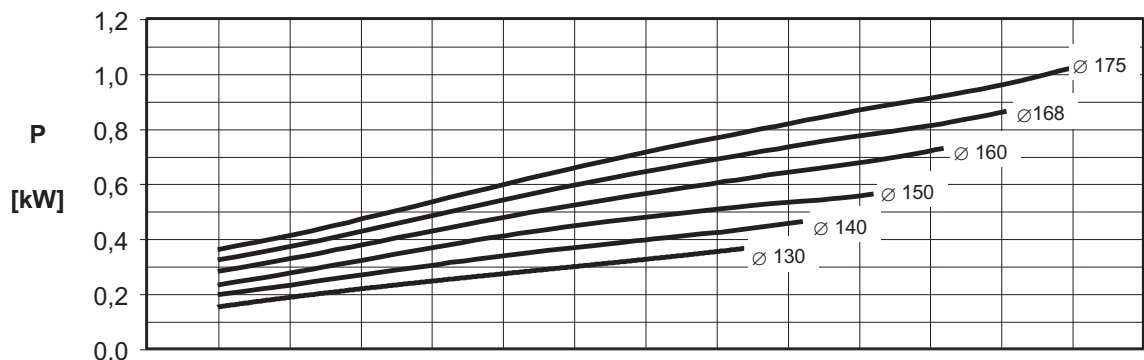
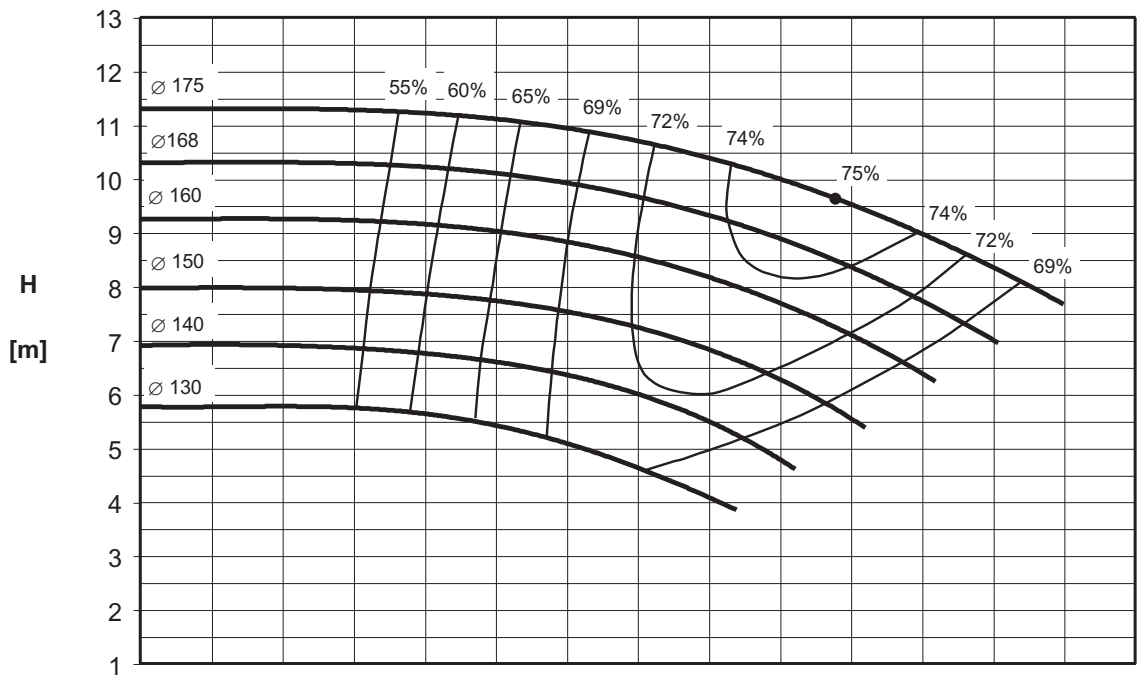

Rotation speed $\approx 1450 \text{ min}^{-1}$
Test standard: ISO 9906 – Annex A

ENR4 40-200 MEI > 0.40

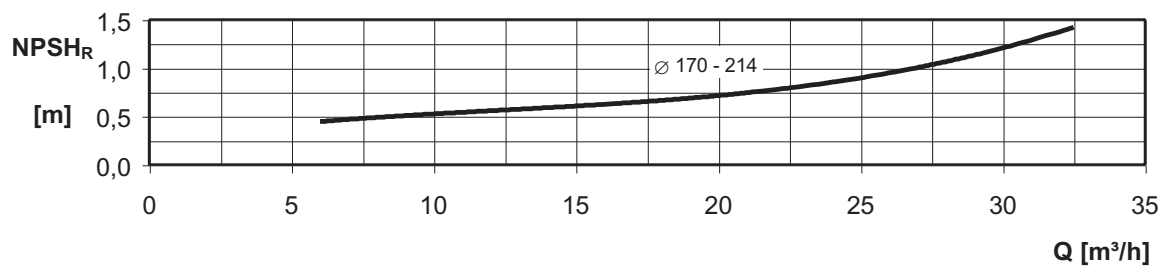
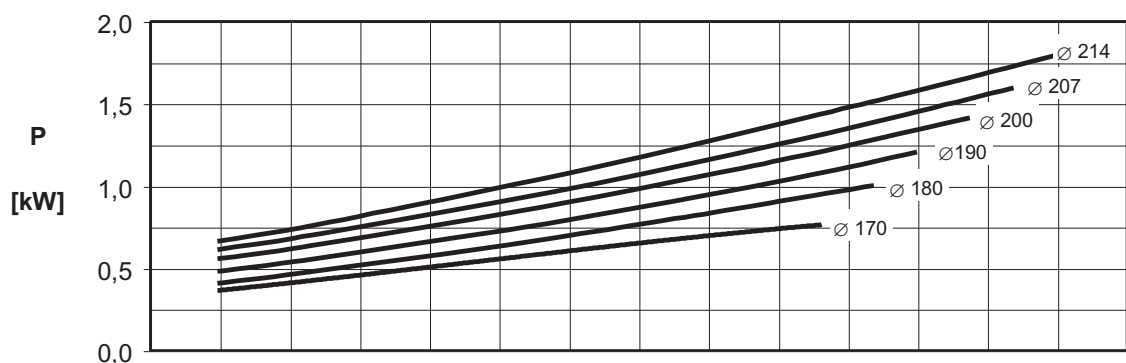
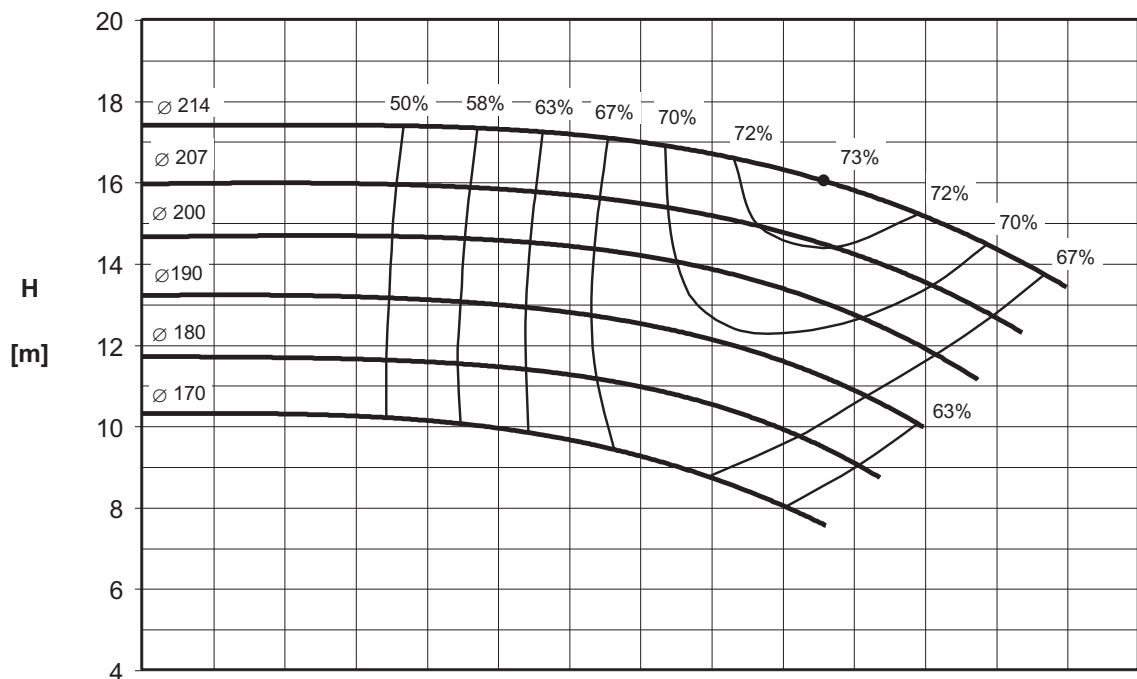

Rotation speed $\approx 1450 \text{ min}^{-1}$
Test standard: ISO 9906 – Annex A

ENR4 40-250 MEI > 0.40

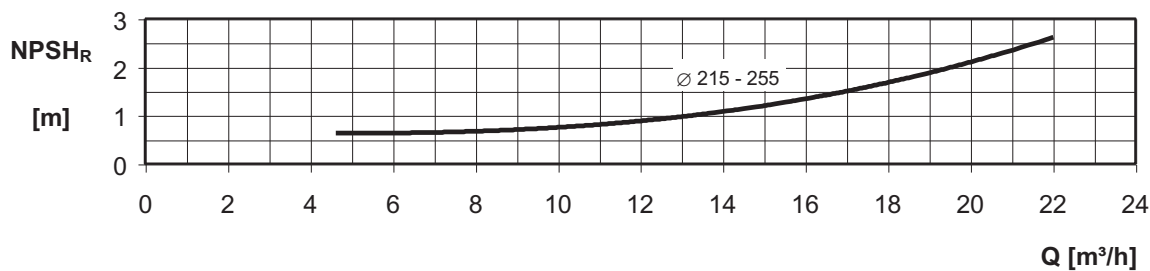
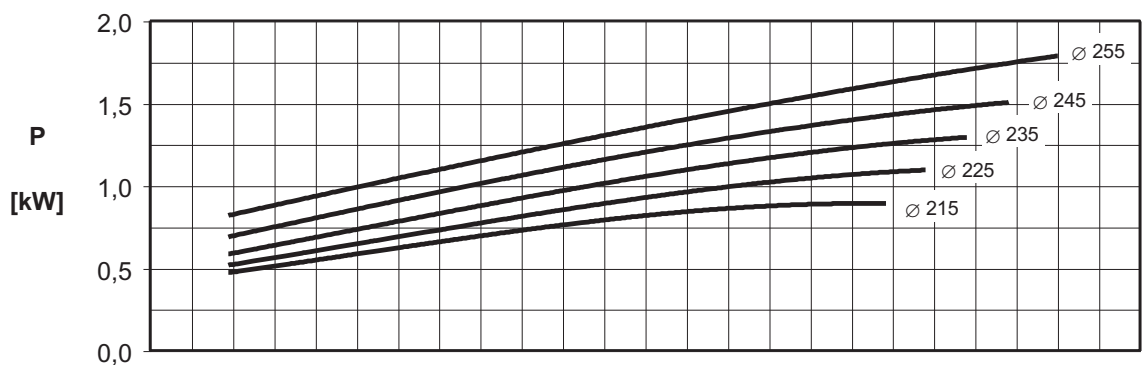
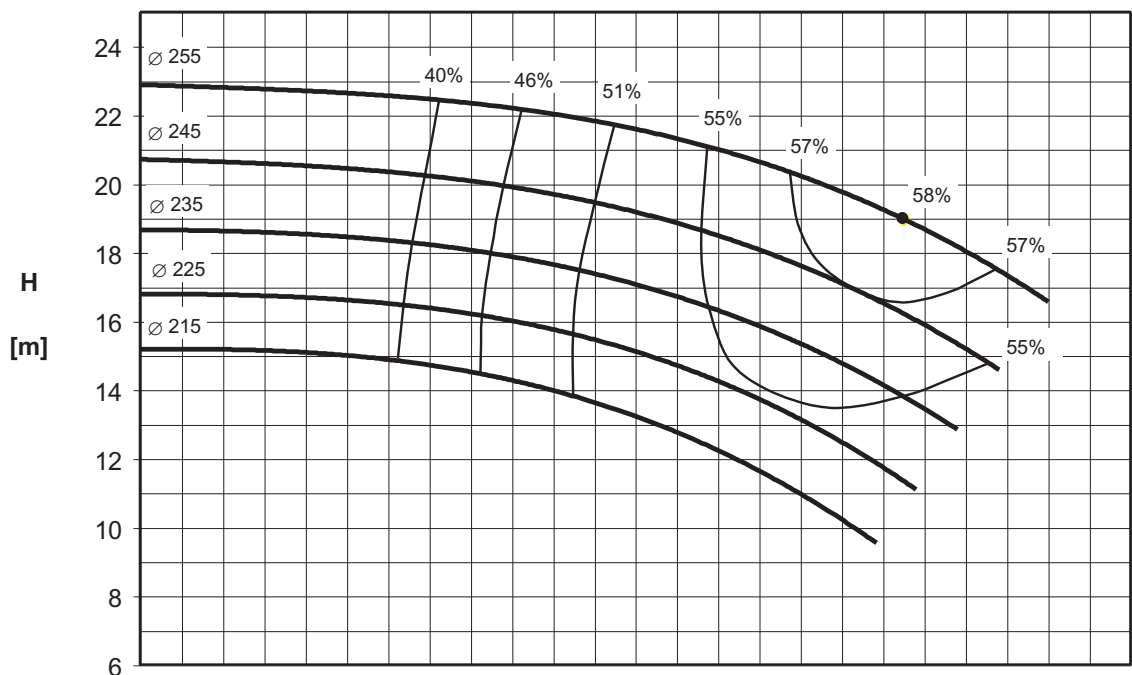

Rotation speed $\approx 1450 \text{ min}^{-1}$
Test standard: ISO 9906 – Annex A

ENR4 40-315 MEI > 0.40

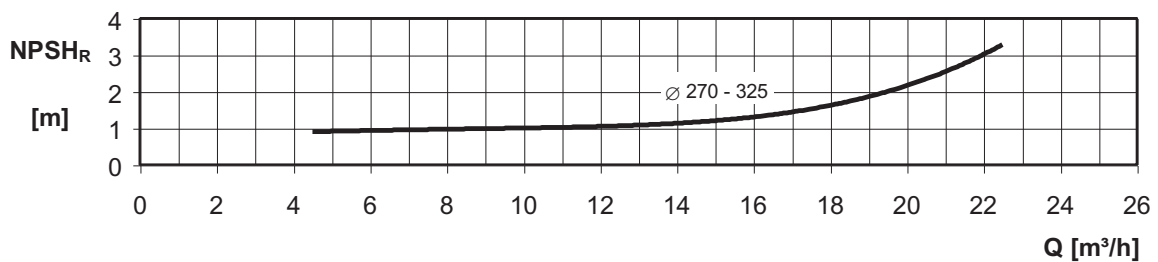
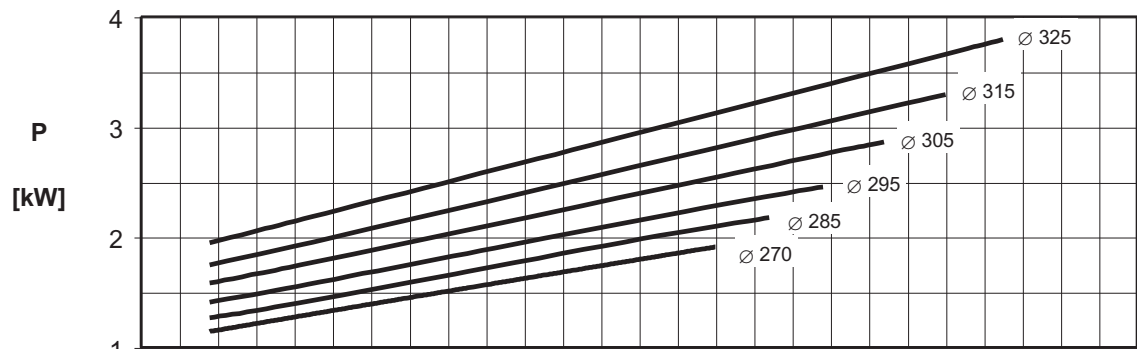
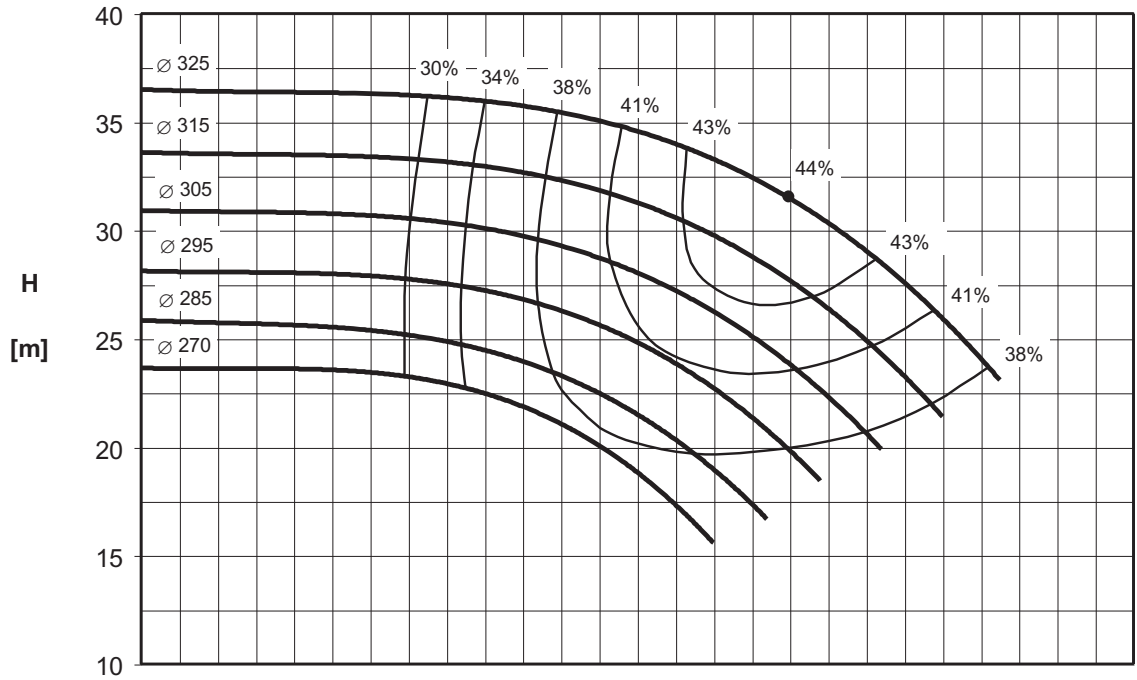

Rotation speed $\approx 2900 \text{ min}^{-1}$
Test standard: ISO 9906 – Annex A

ENR4 50-125 MEI > 0.40

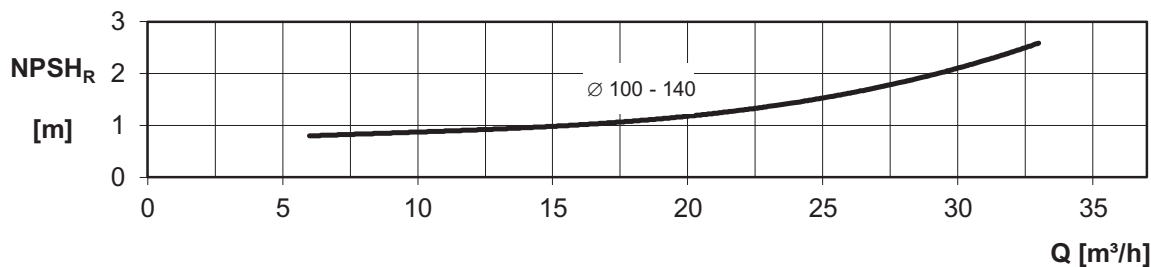
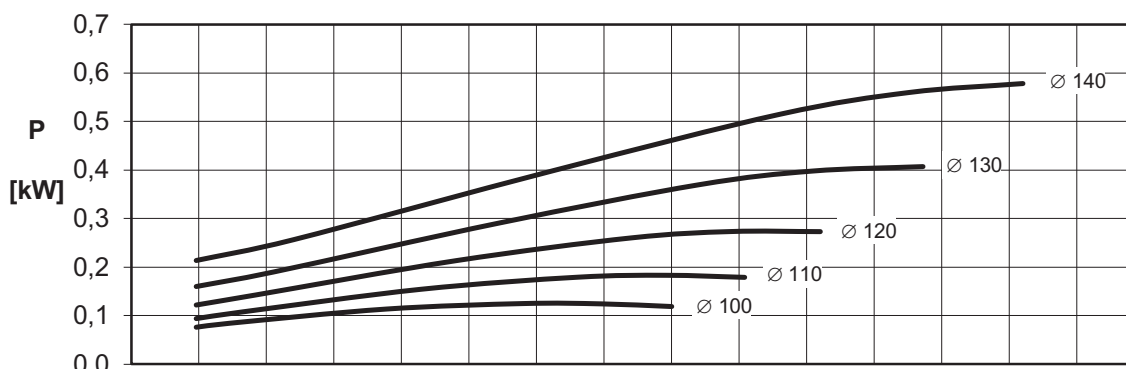
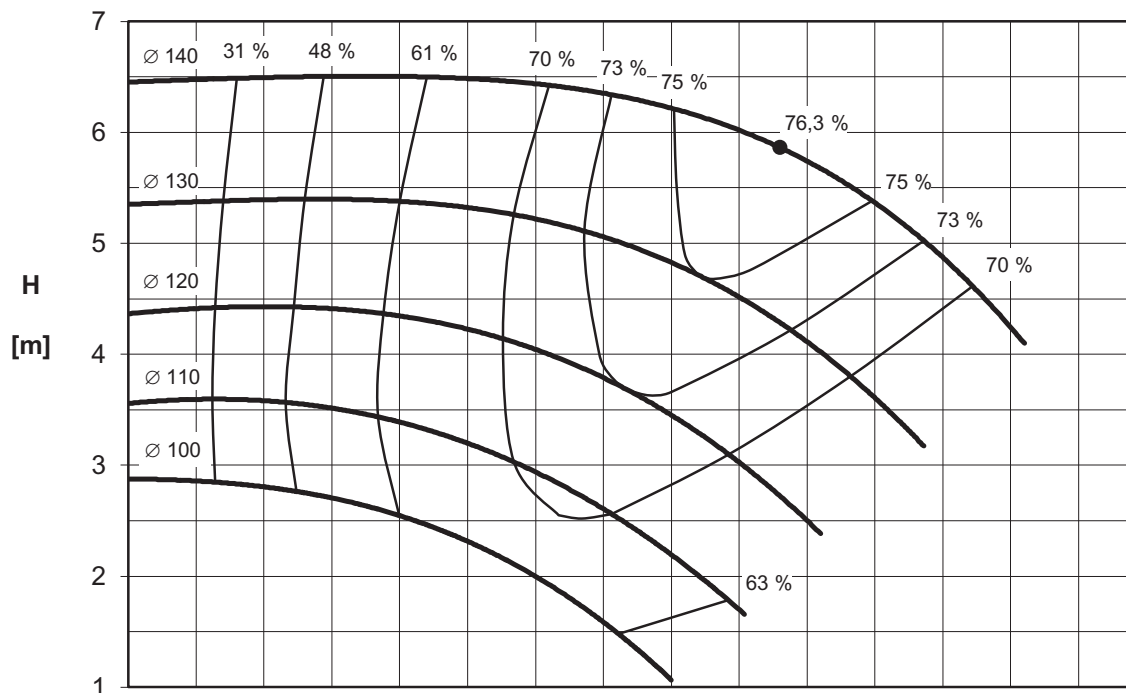

Rotation speed $\approx 1450 \text{ min}^{-1}$
Test standard: ISO 9906 – Annex A

ENR4 50-160 MEI > 0.40

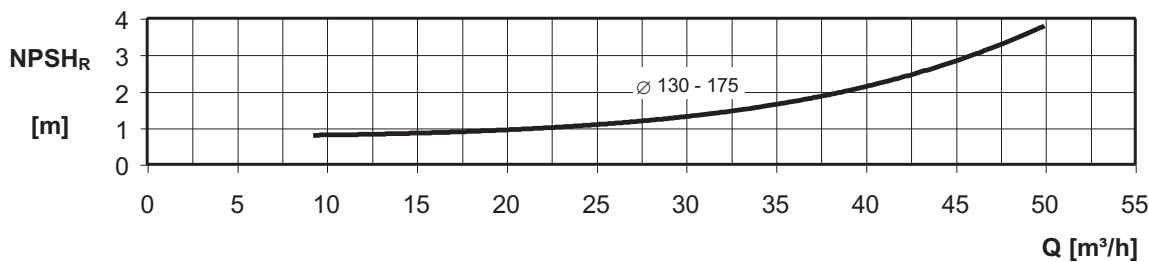
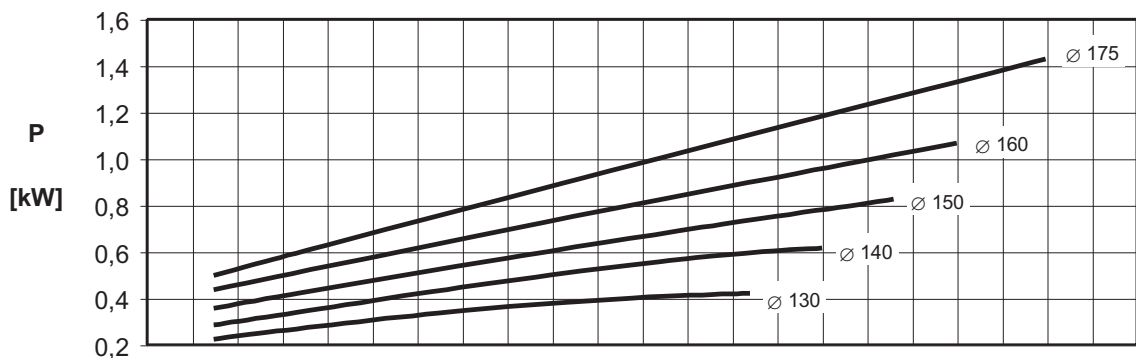
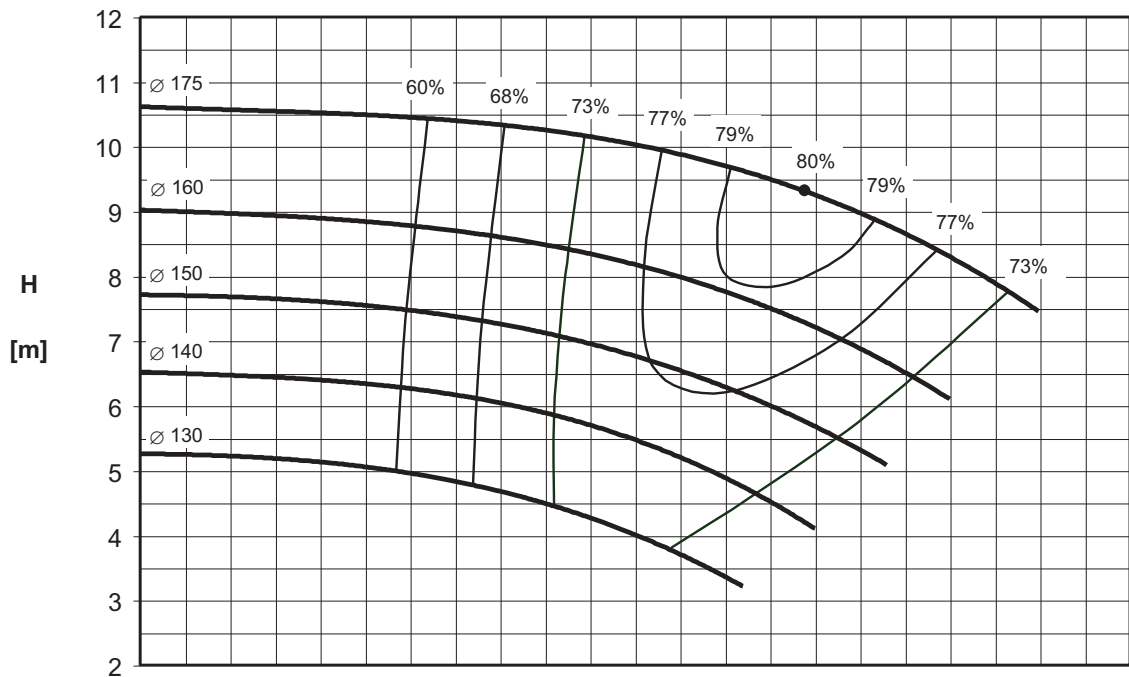

Rotation speed $\approx 1450 \text{ min}^{-1}$
Test standard: ISO 9906 – Annex A

ENR4 50-200 MEI > 0.40

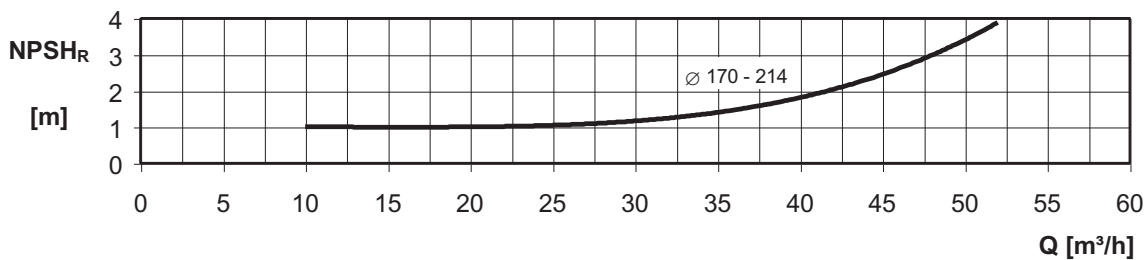
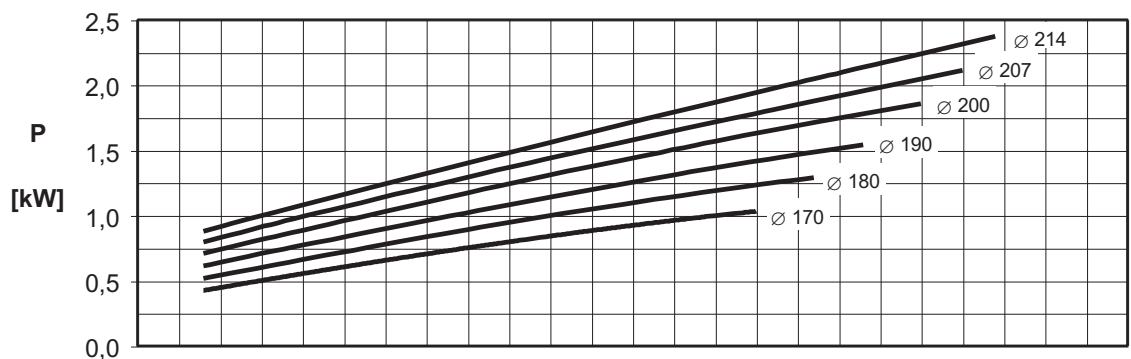
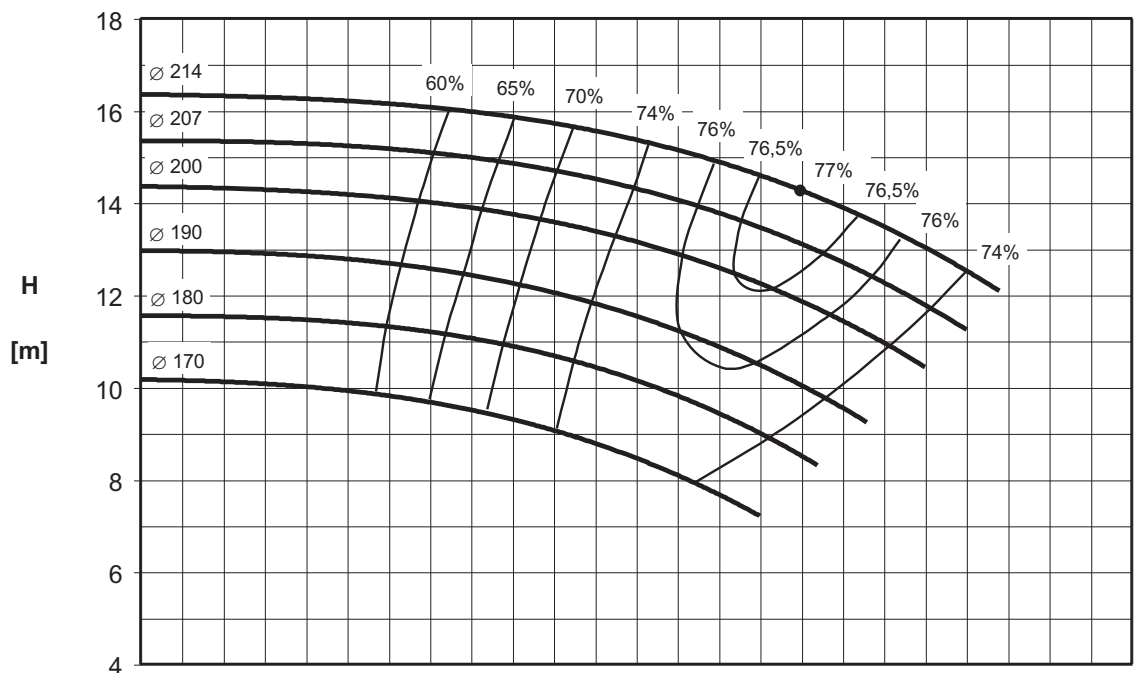

Rotation speed $\approx 1450 \text{ min}^{-1}$
Test standard: ISO 9906 – Annex A

ENR4 50-250 MEI > 0.40

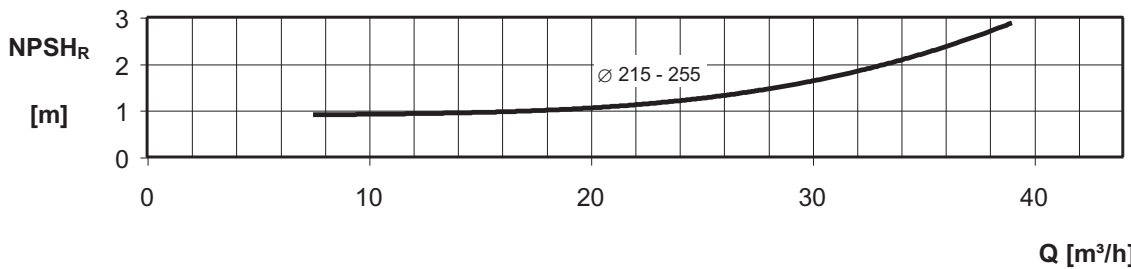
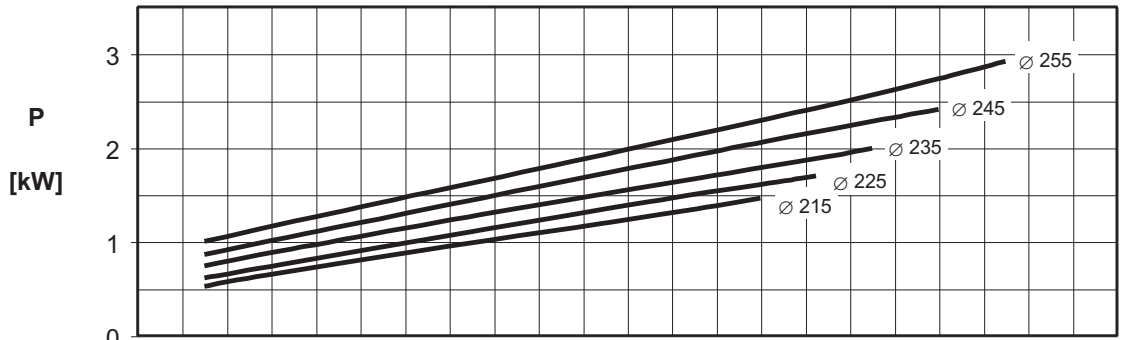
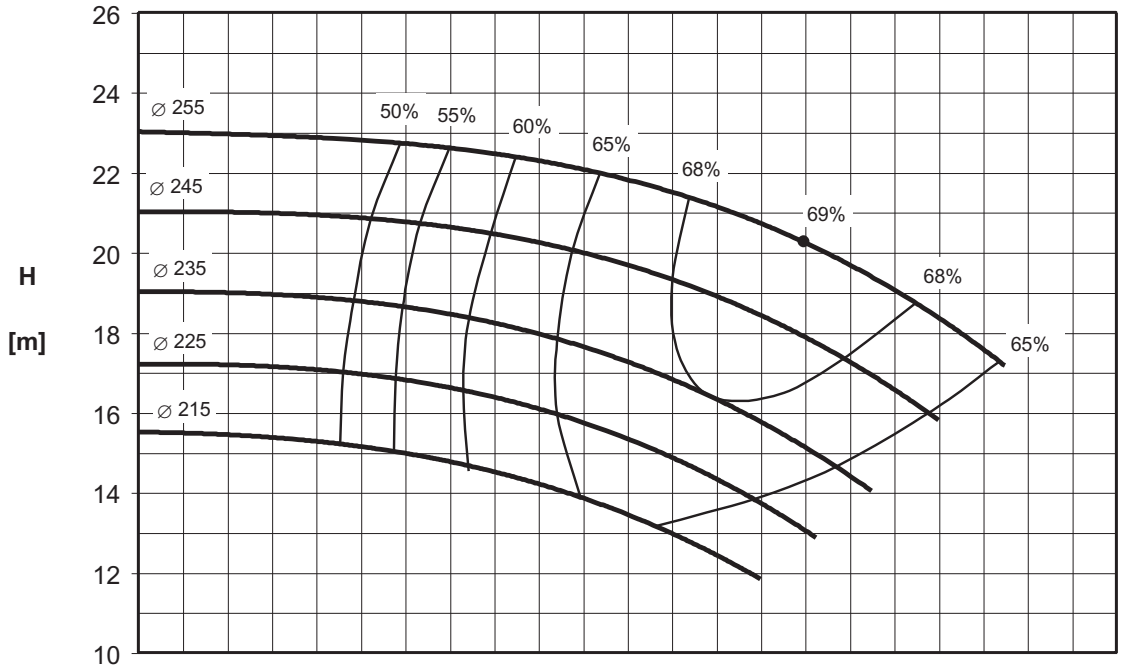

Rotation speed $\approx 1450 \text{ min}^{-1}$
Test standard: ISO 9906 – Annex A

ENR4 50-315 MEI > 0.40

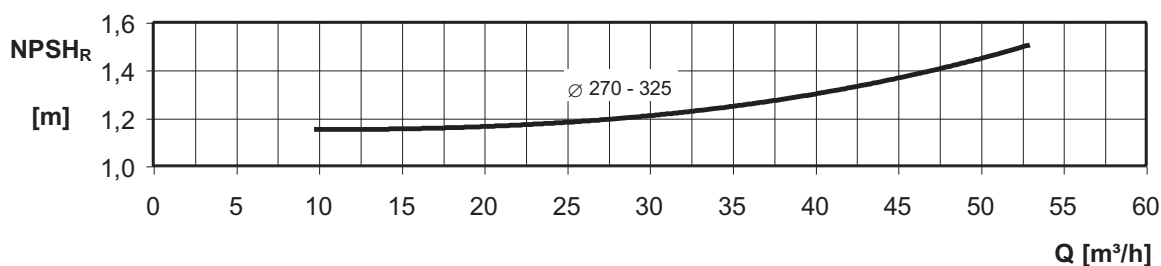
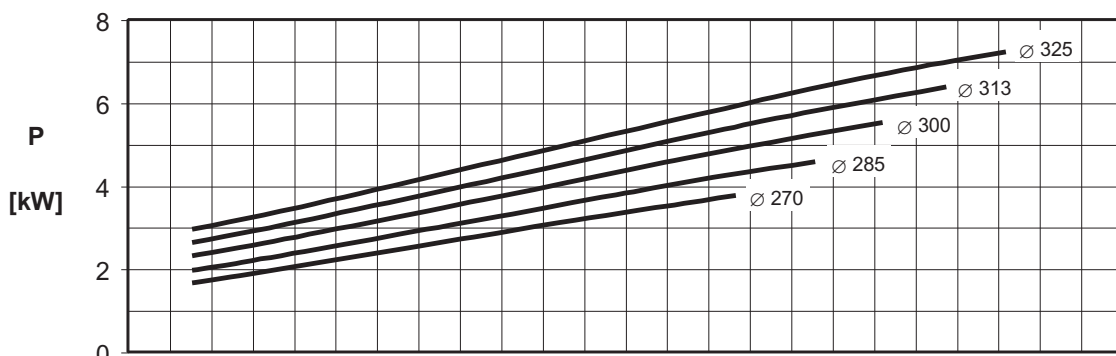
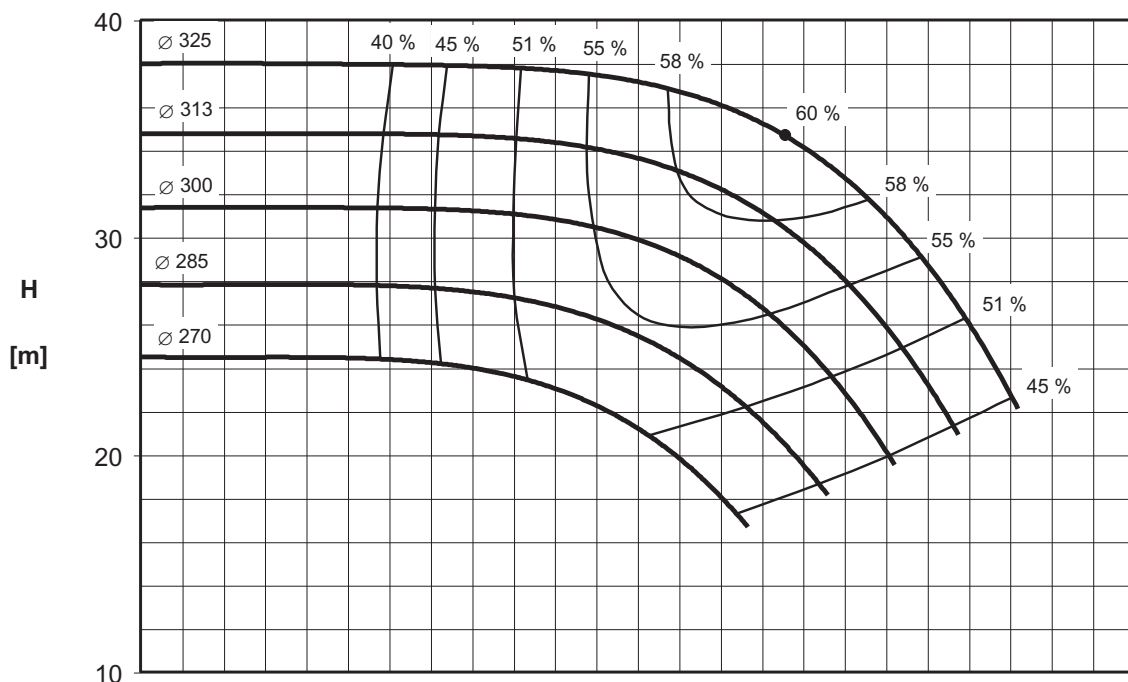

Rotation speed $\approx 1450 \text{ min}^{-1}$
Test standard: ISO 9906 – Annex A

ENR4 65-125 MEI > 0.40

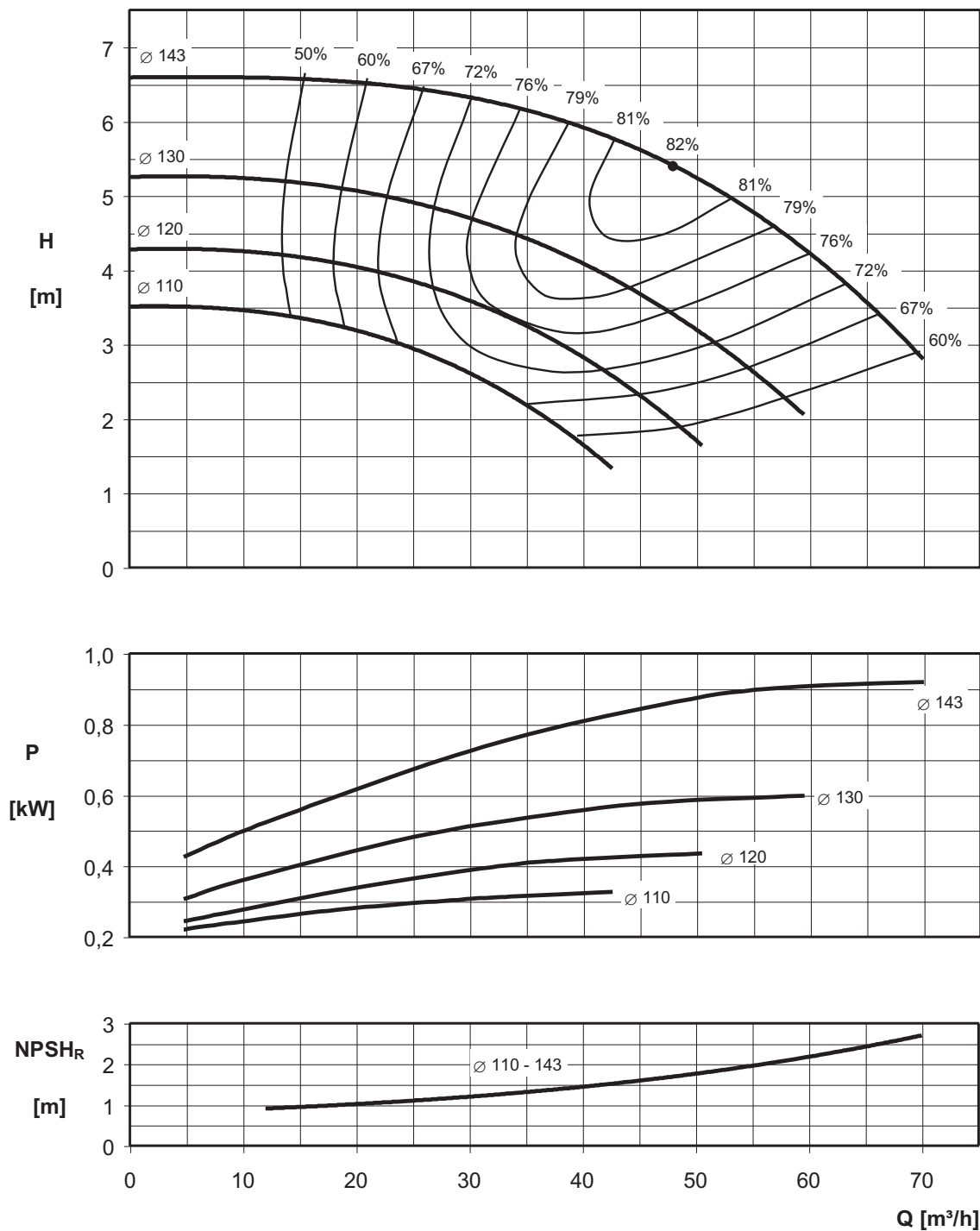

Rotation speed $\approx 1450 \text{ min}^{-1}$
Test standard: ISO 9906 – Annex A

ENR4 65-160 MEI > 0.40

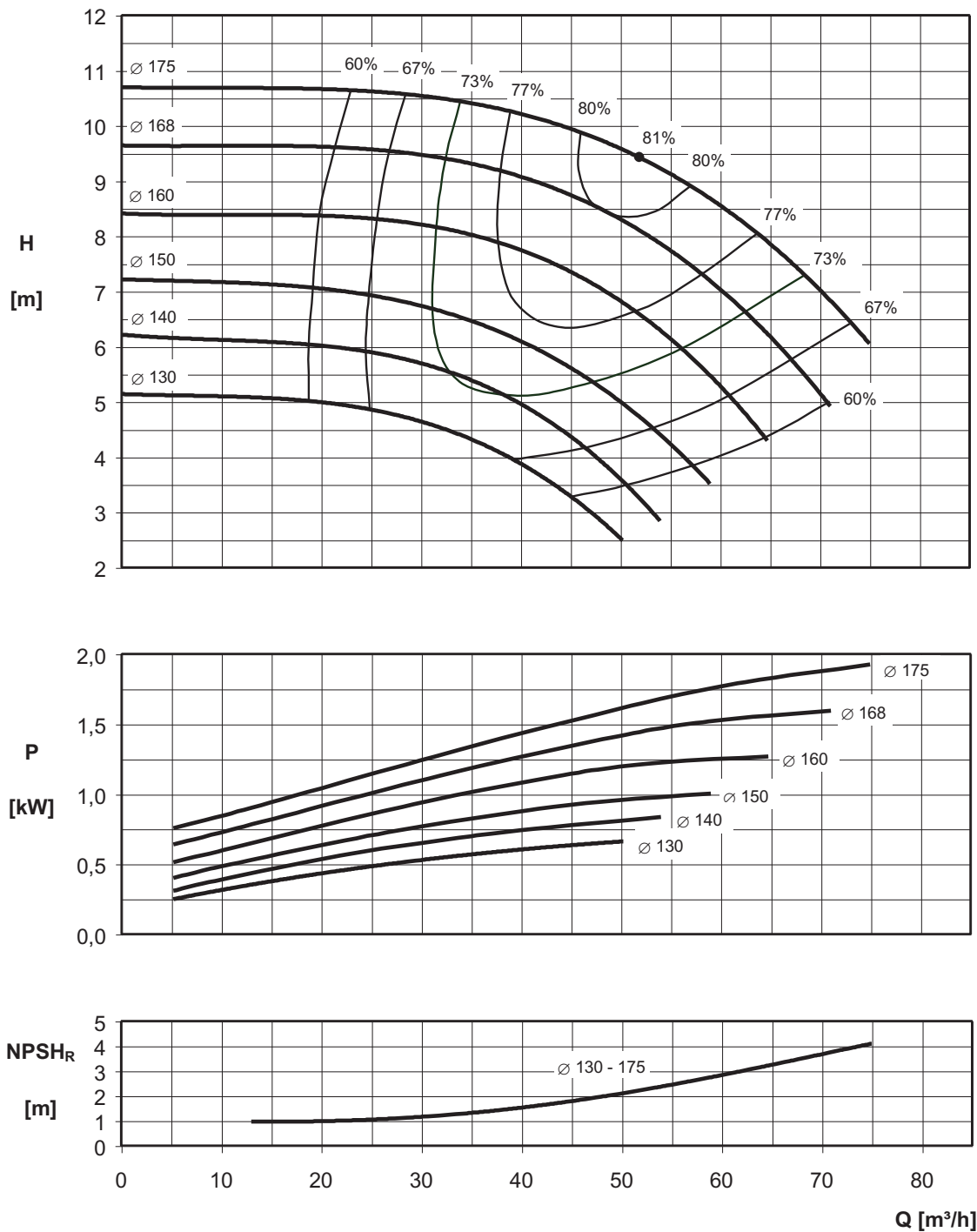

Rotation speed $\approx 1450 \text{ min}^{-1}$
Test standard: ISO 9906 – Annex A

ENR4 65-200 MEI > 0.40

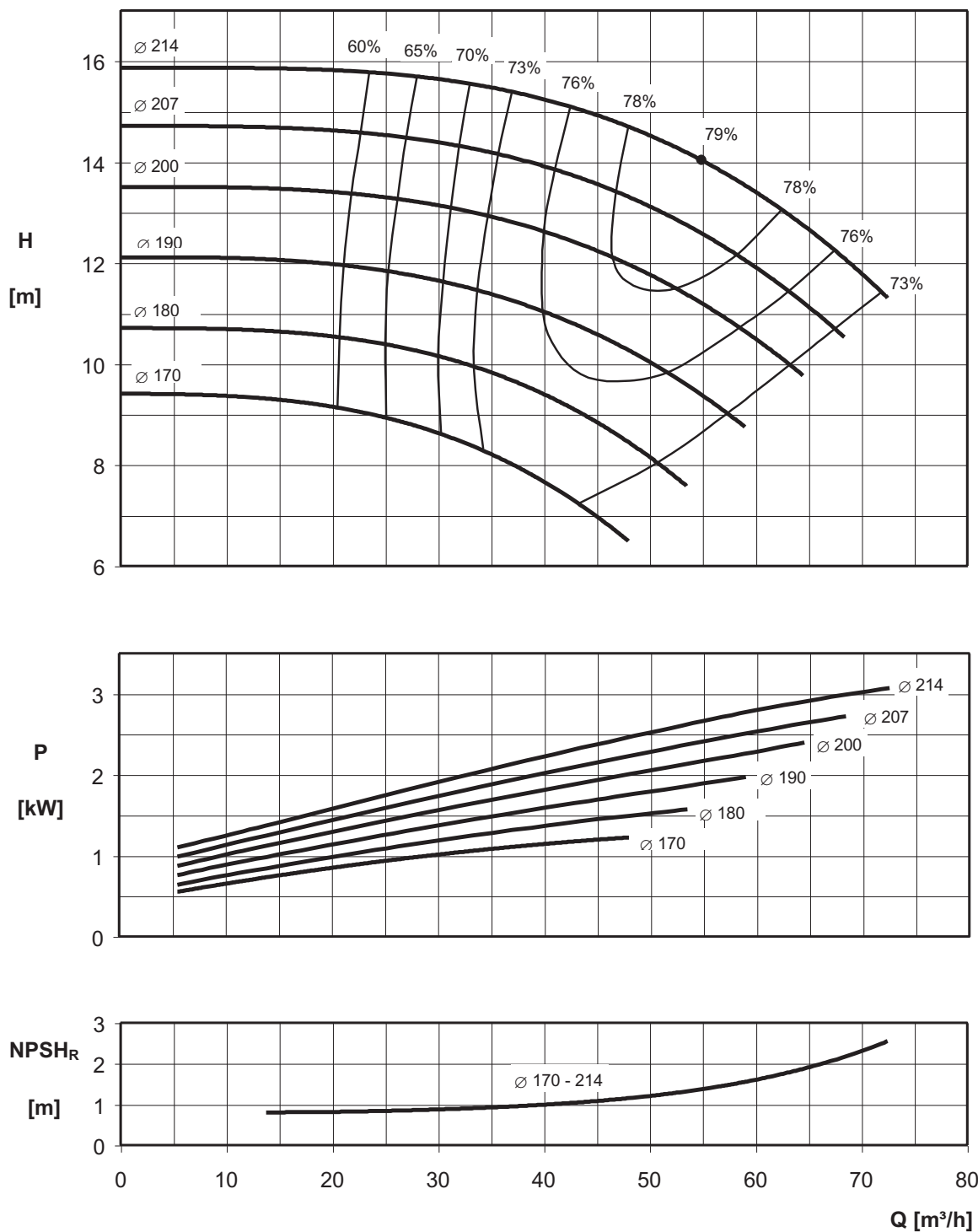

Rotation speed $\approx 1450 \text{ min}^{-1}$
Test standard: ISO 9906 – Annex A

ENR4 65-250 MEI > 0.40

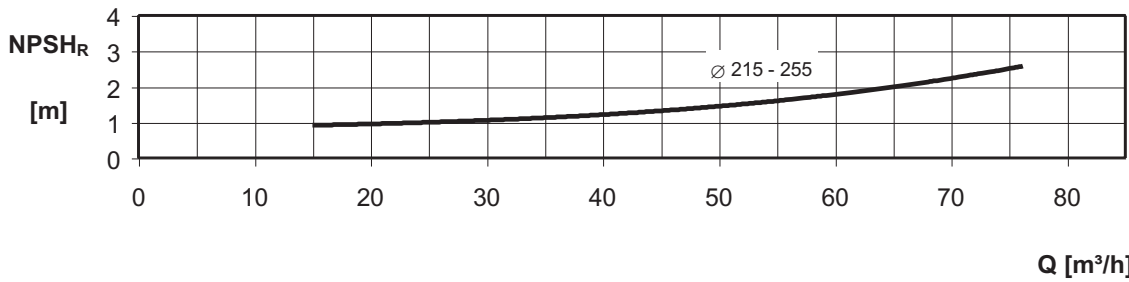
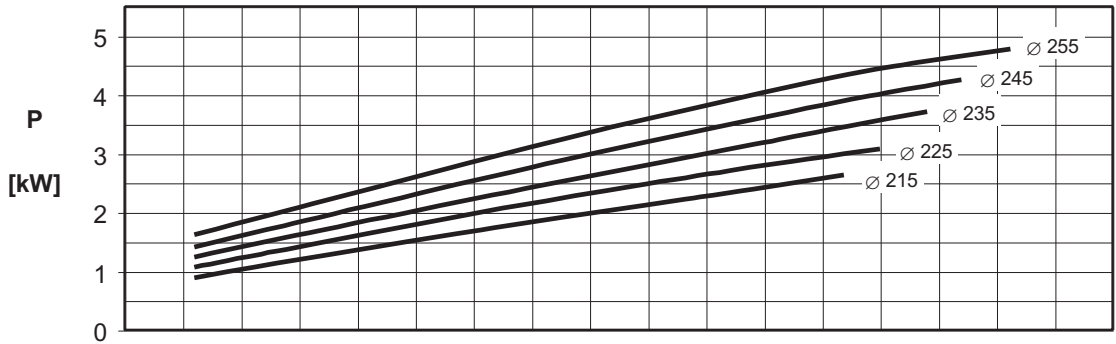
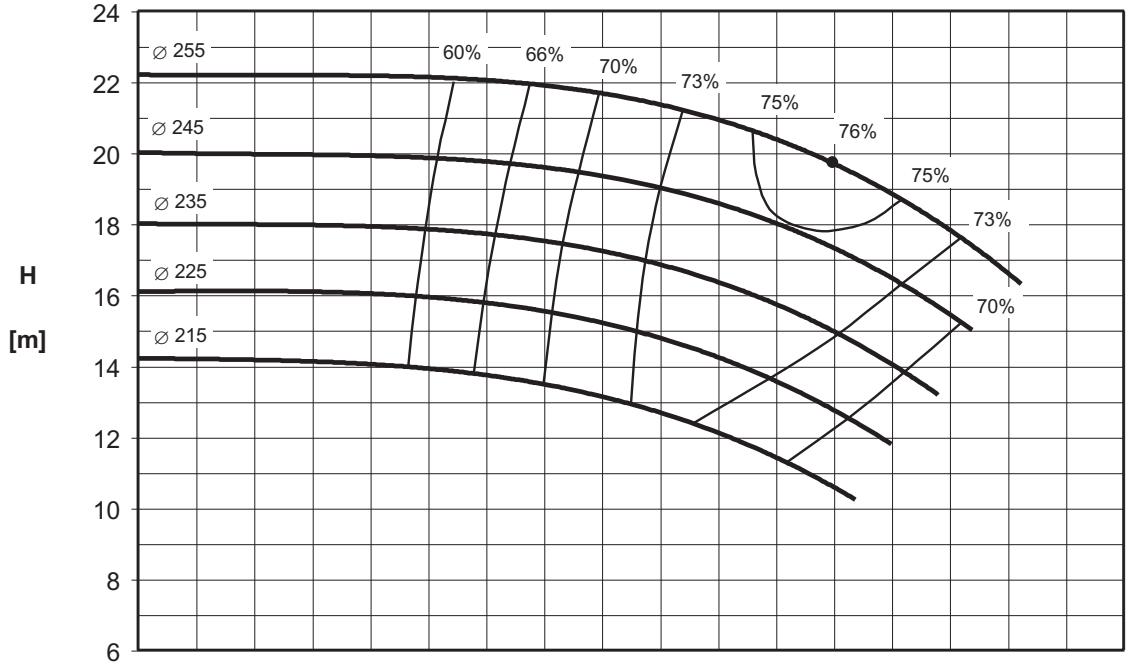

Rotation speed $\approx 1450 \text{ min}^{-1}$
Test standard: ISO 9906 – Annex A

ENR4 65-315 MEI > 0.40

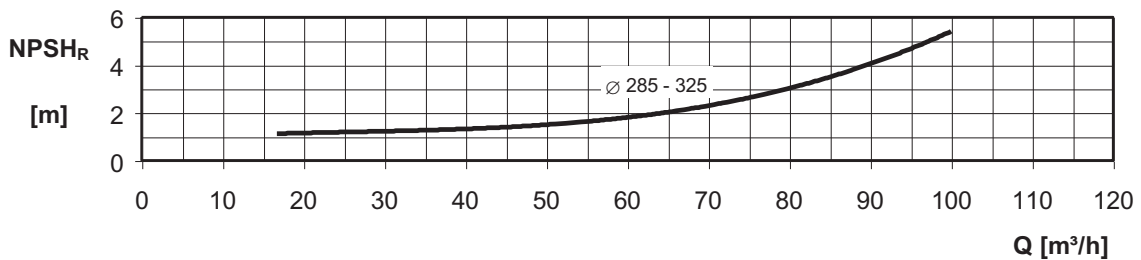
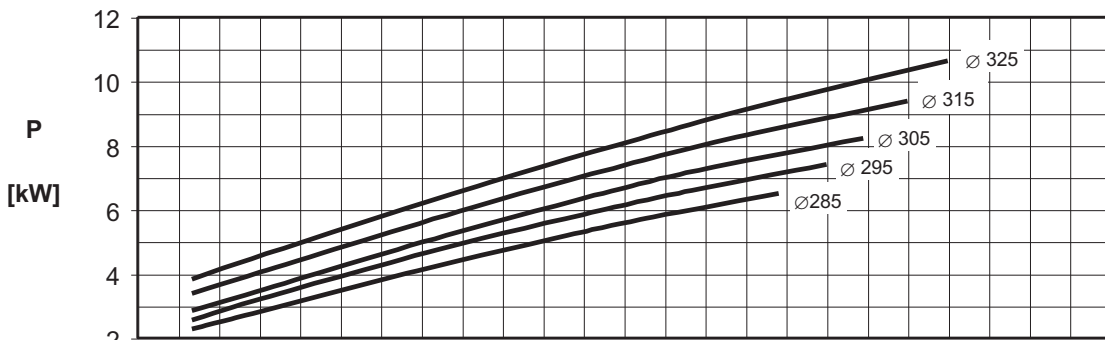
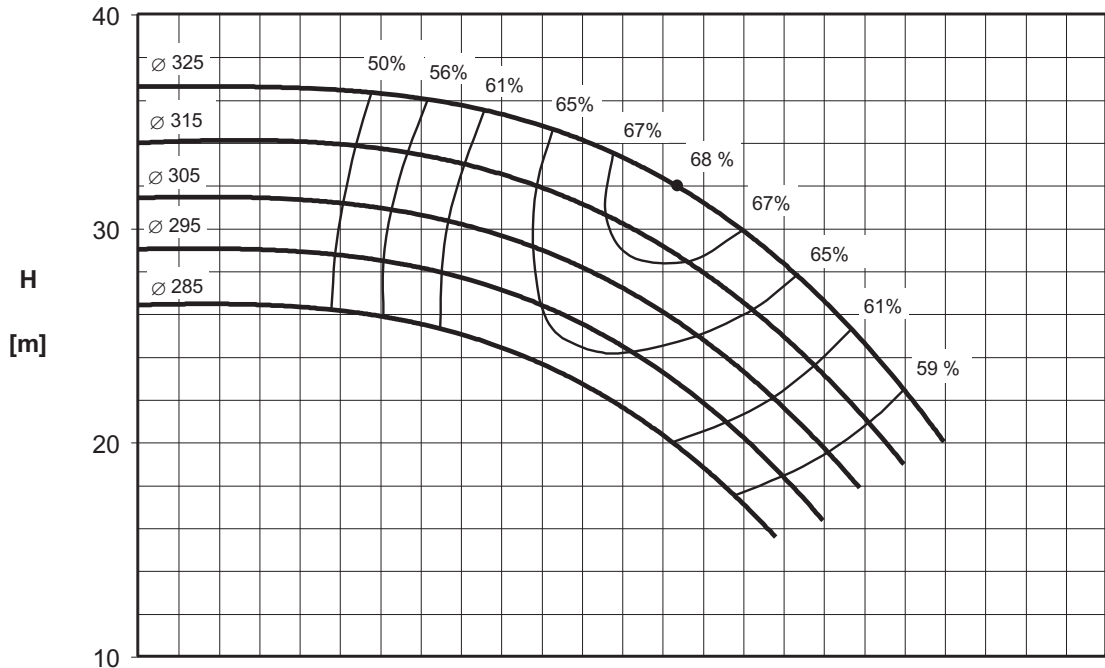

Rotation speed $\approx 1450 \text{ min}^{-1}$
Test standard: ISO 9906 – Annex A

ENR4 80-160 MEI > 0.40

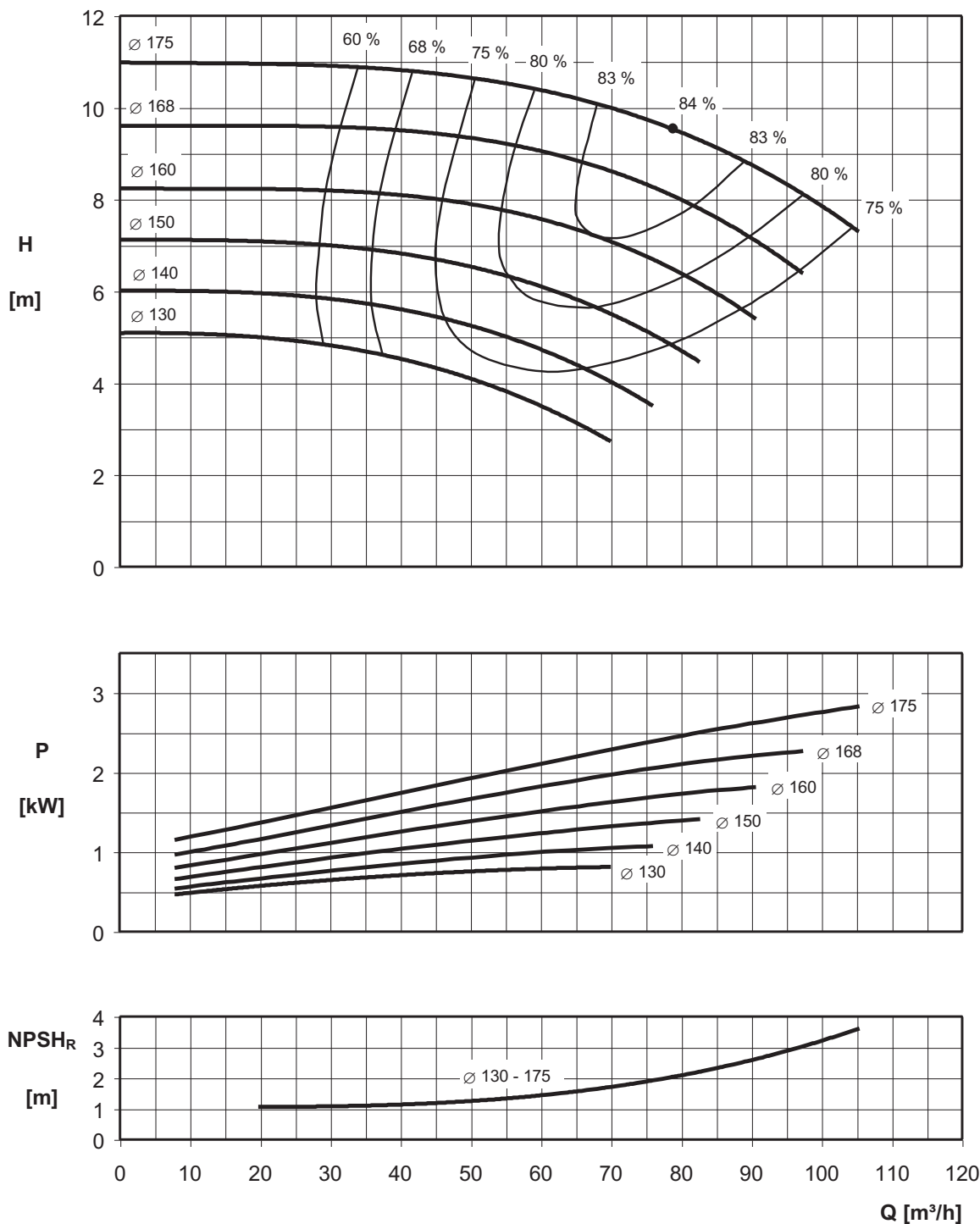

Rotation speed $\approx 1450 \text{ min}^{-1}$
Test standard: ISO 9906 – Annex A

ENR4 80-200 MEI > 0.40

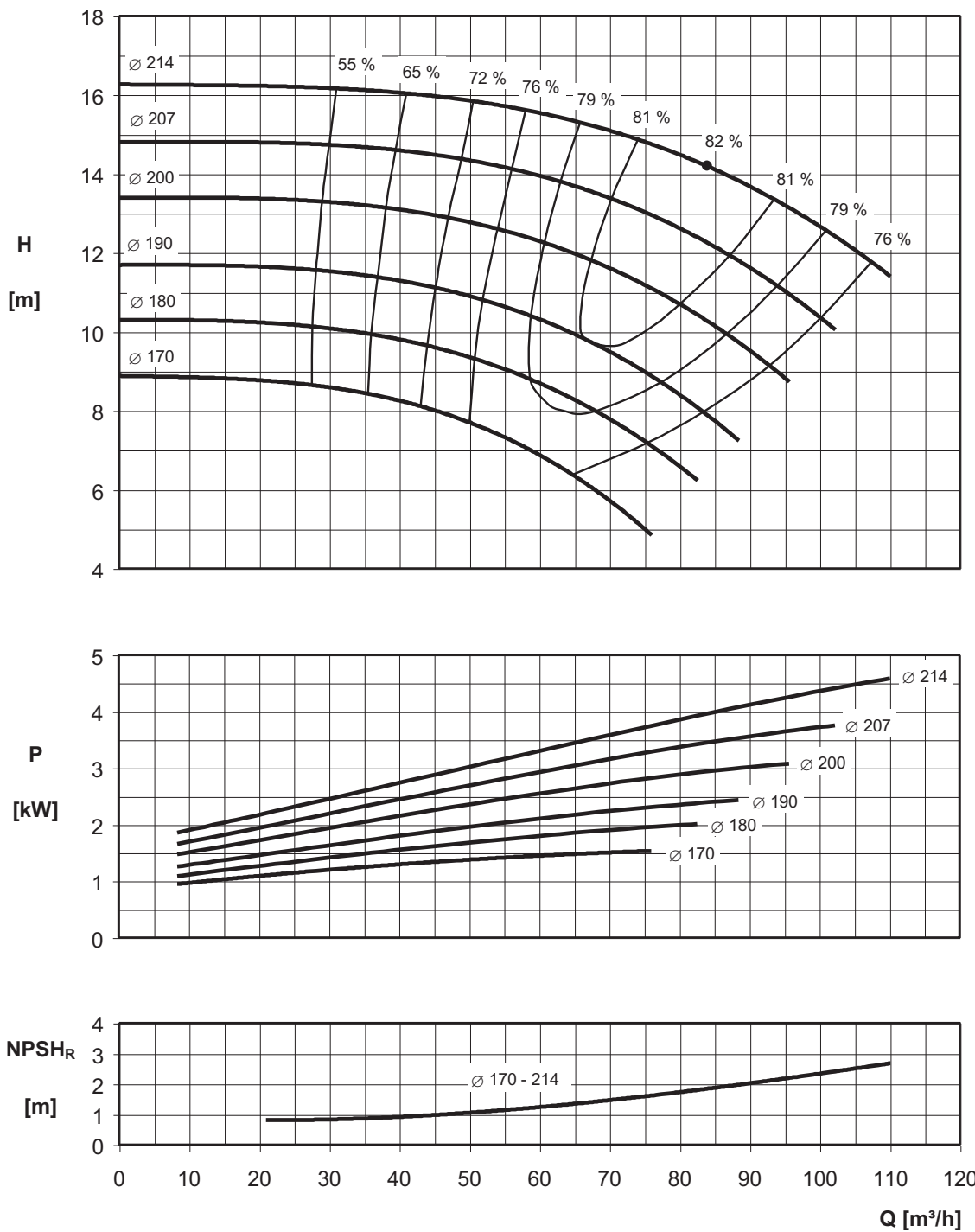

Rotation speed $\approx 1450 \text{ min}^{-1}$
Test standard: ISO 9906 – Annex A

ENR4 80-250 MEI > 0.40

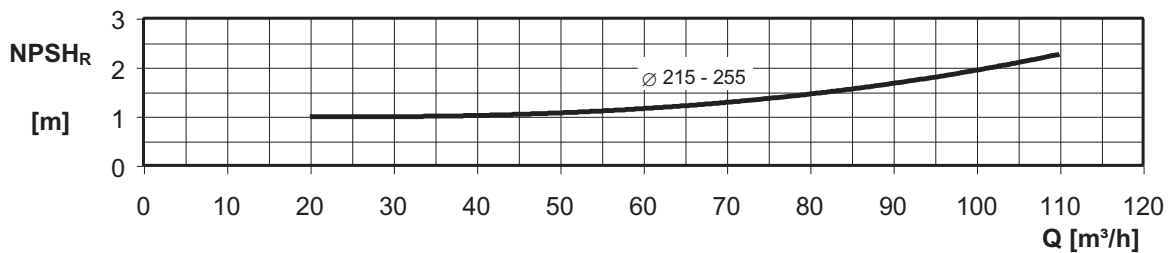
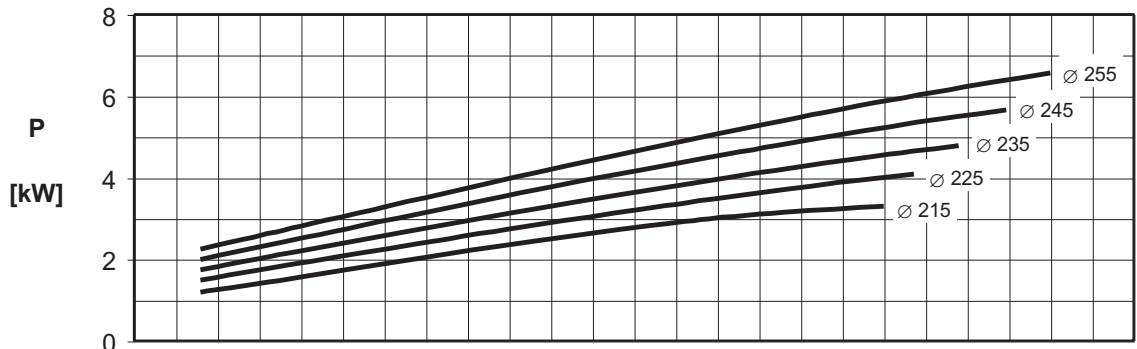
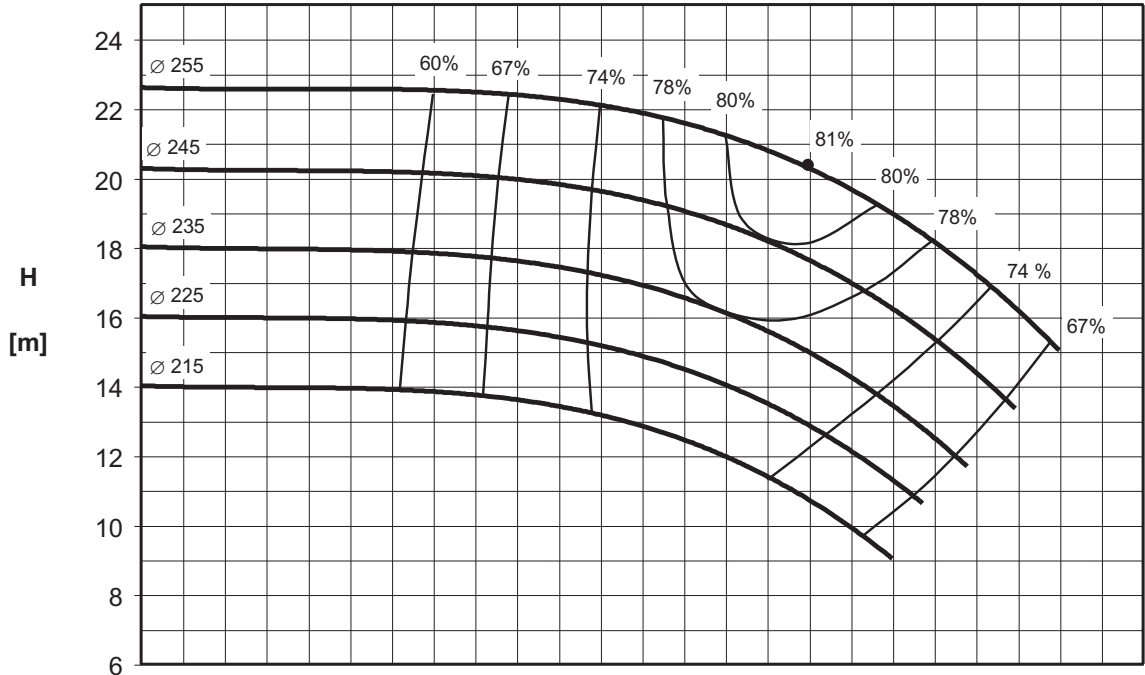

Rotation speed $\approx 1450 \text{ min}^{-1}$
Test standard: ISO 9906 – Annex A

ENR4 80-315 MEI > 0.40

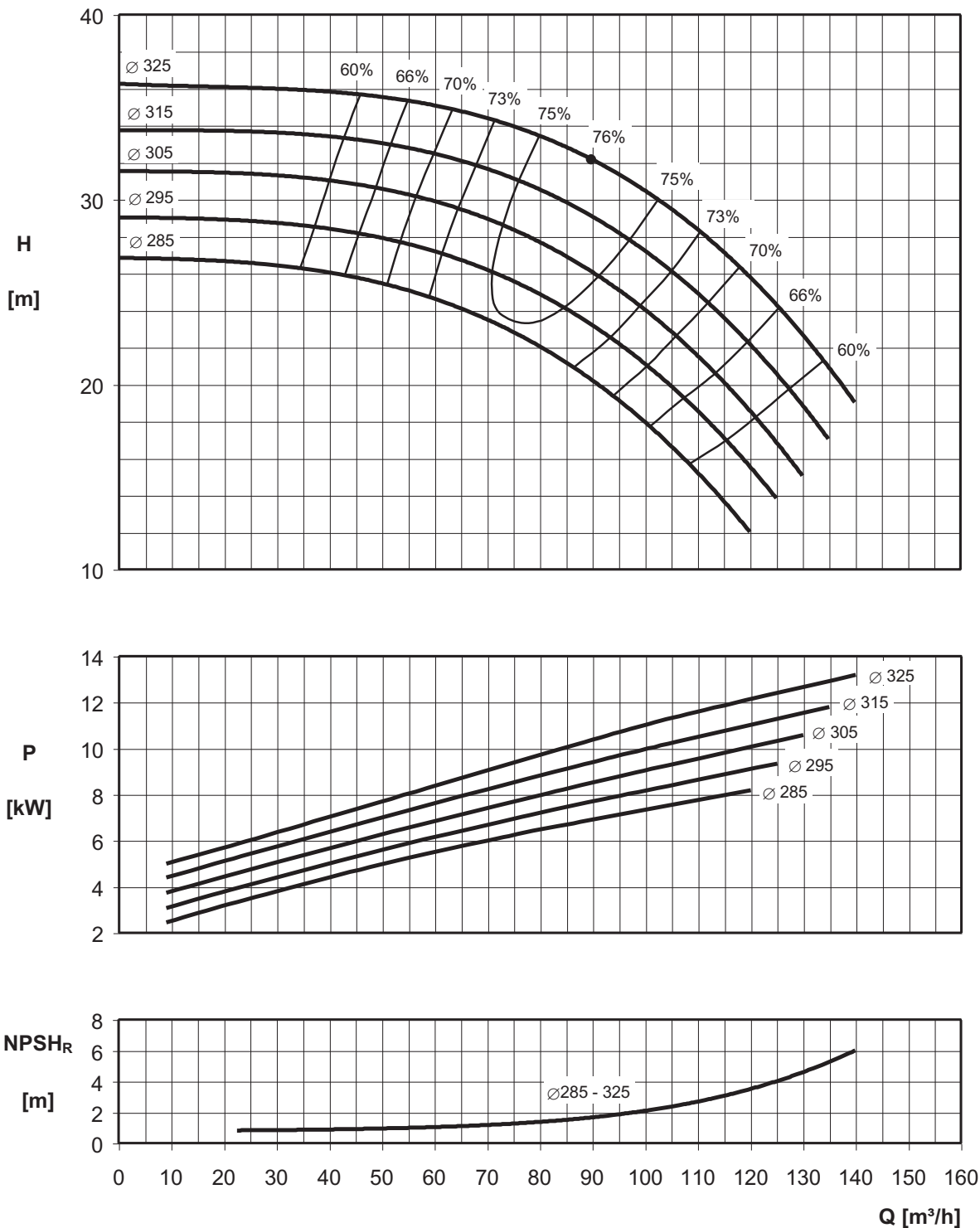

Rotation speed $\approx 1450 \text{ min}^{-1}$
Test standard: ISO 9906 – Annex A

ENR4 80-400 MEI > 0.40

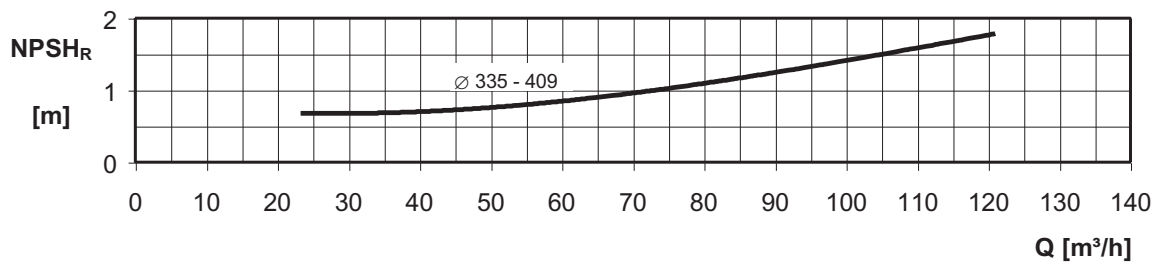
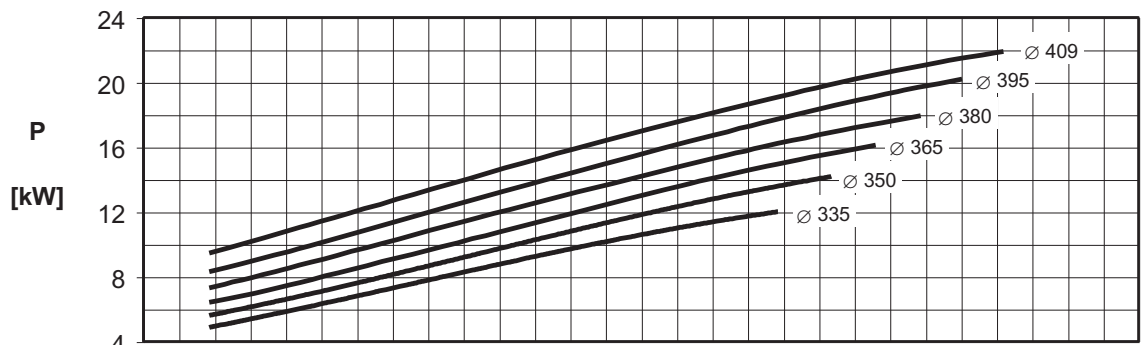
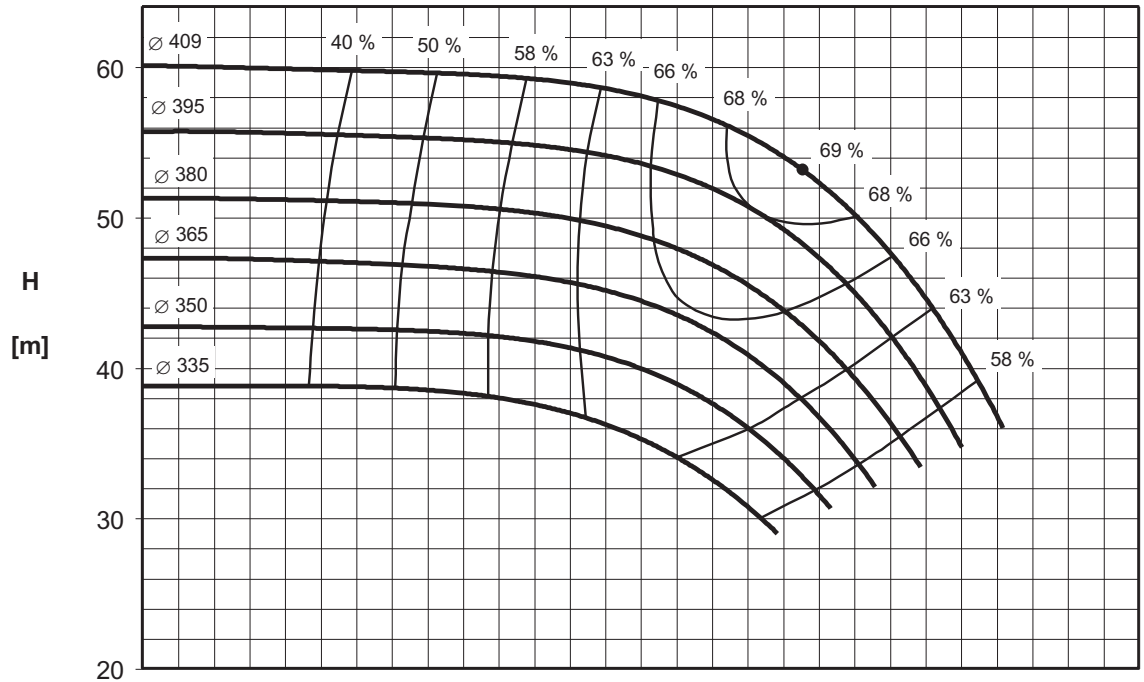

Rotation speed $\approx 1450 \text{ min}^{-1}$
Test standard: ISO 9906 – Annex A

ENR4 100-160 MEI > 0.40

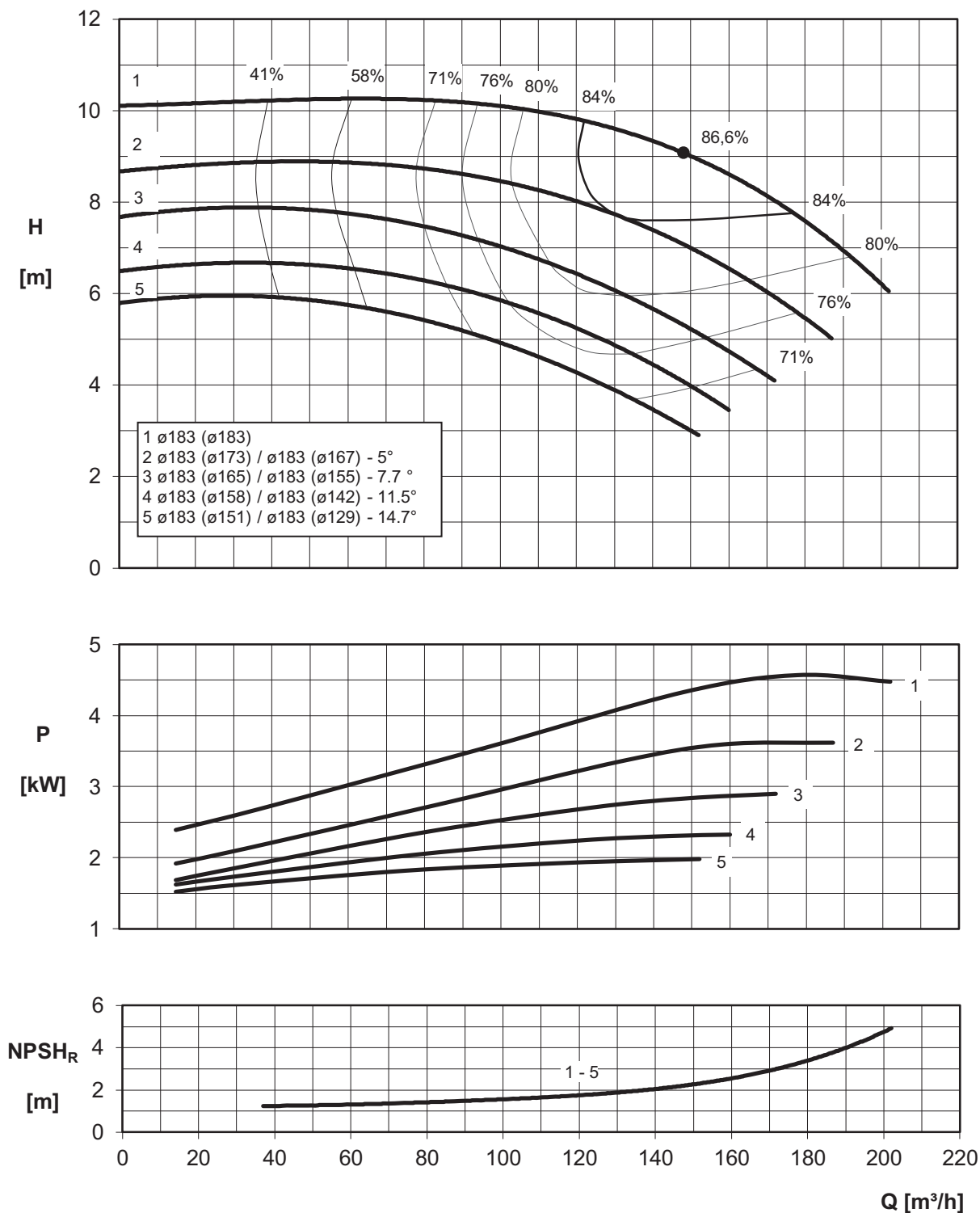

Rotation speed $\approx 1450 \text{ min}^{-1}$
 Test standard: ISO 9906 – Annex A

ENR4 100-200 MEI > 0.40

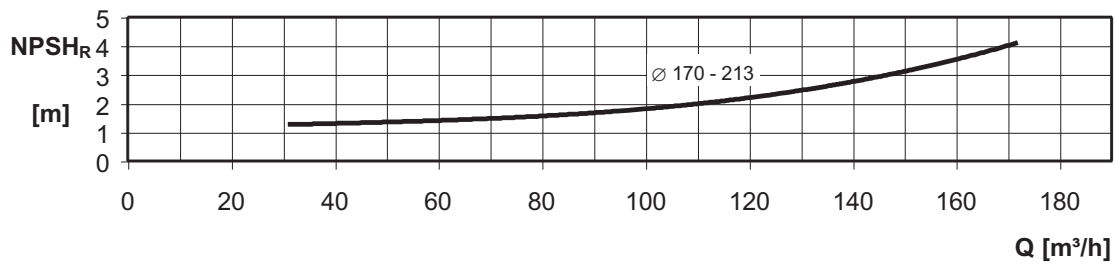
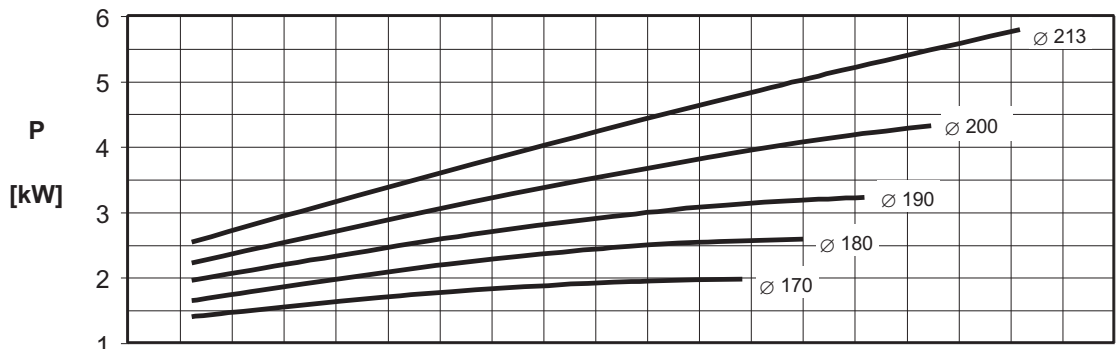
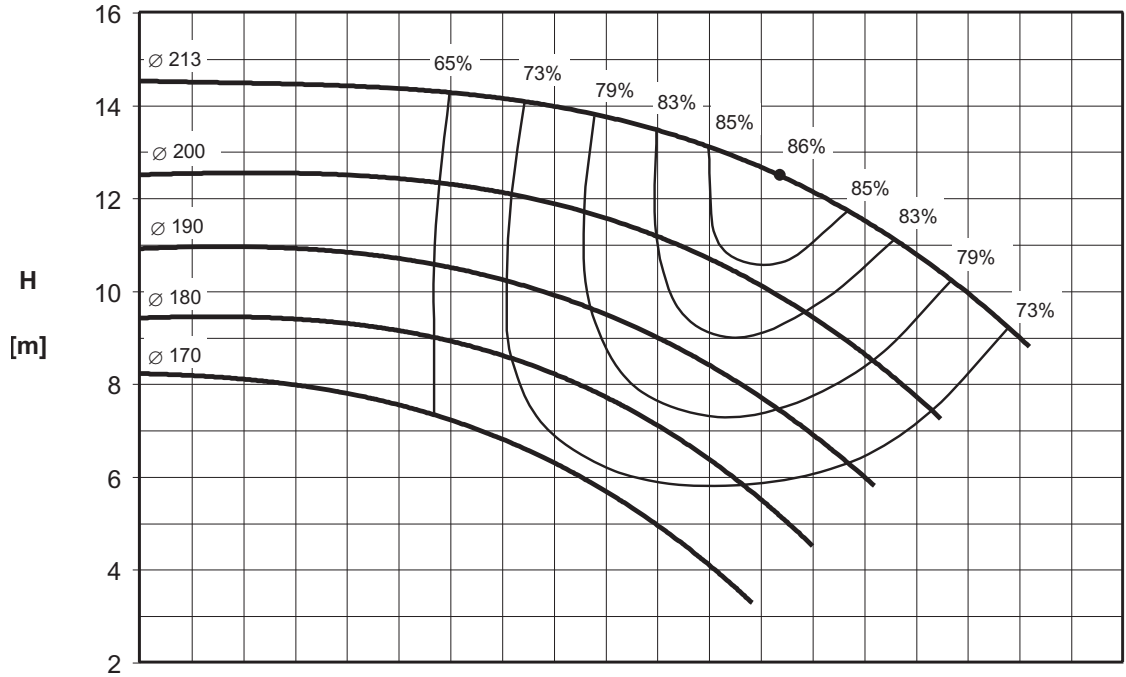

Rotation speed $\approx 1450 \text{ min}^{-1}$
Test standard: ISO 9906 – Annex A

ENR4 100-250 MEI > 0.40

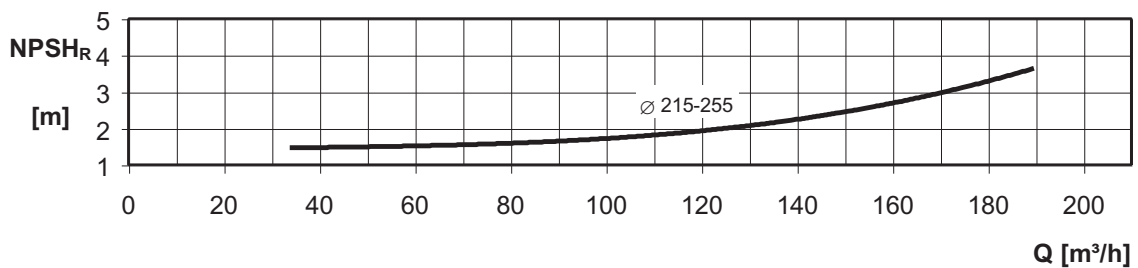
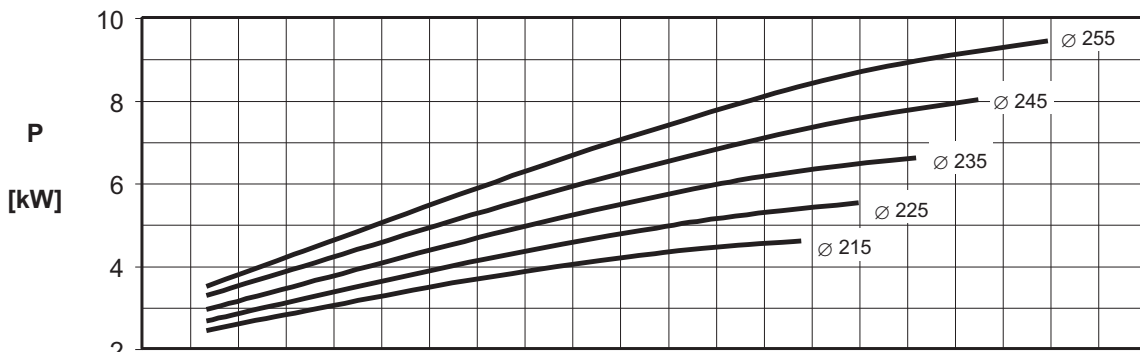
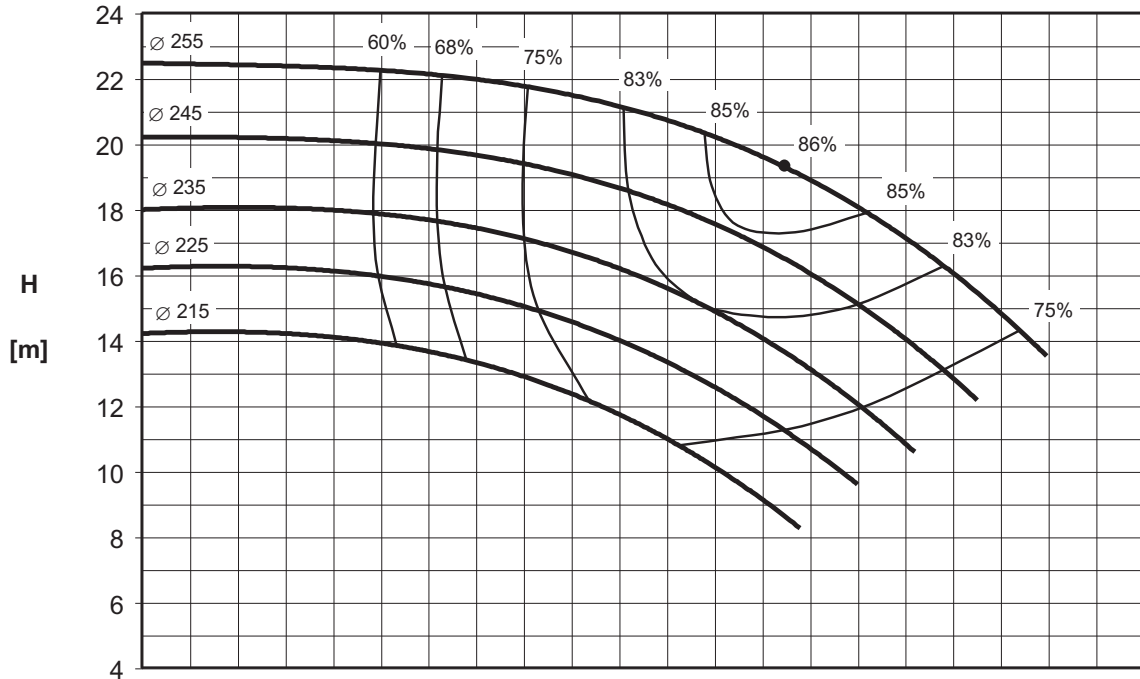

Rotation speed $\approx 1450 \text{ min}^{-1}$
Test standard: ISO 9906 – Annex A

ENR4 100-315 MEI > 0.40

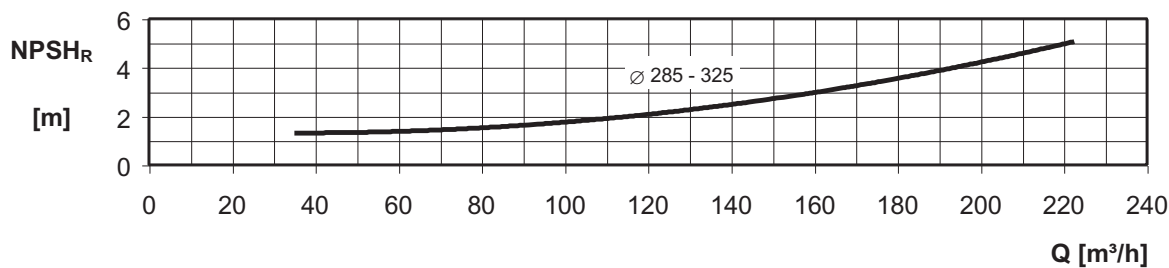
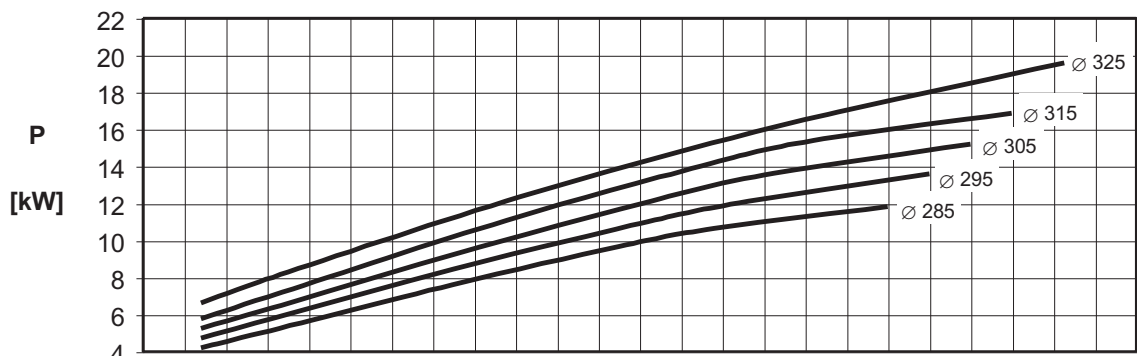
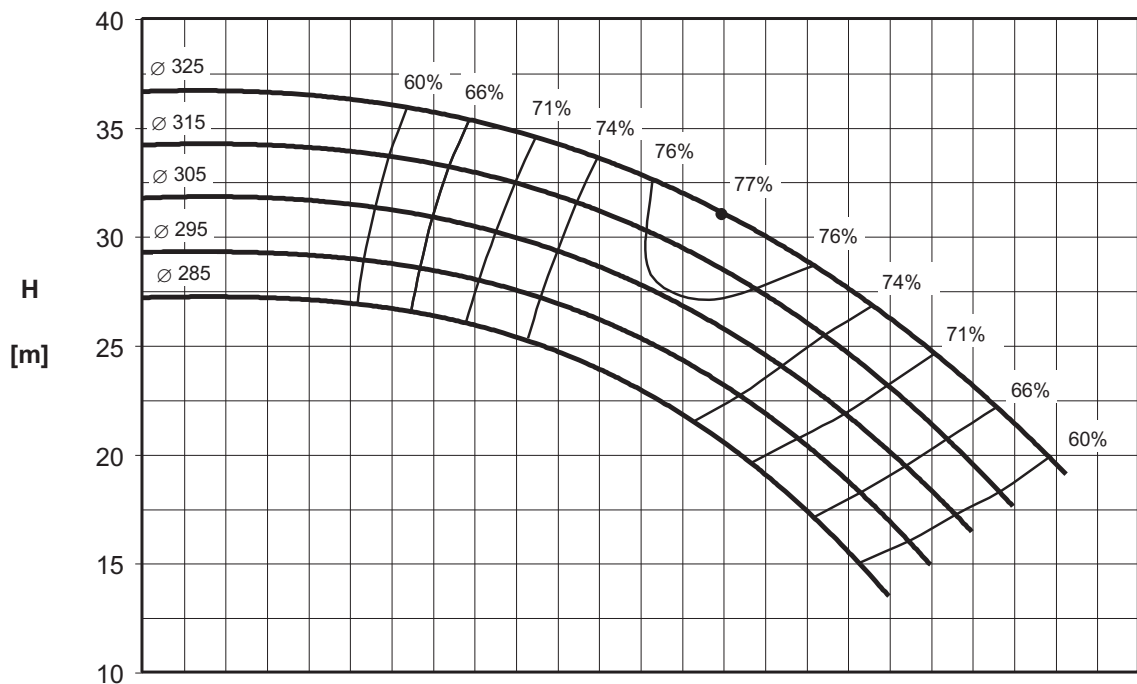

Rotation speed $\approx 1450 \text{ min}^{-1}$
 Test standard: ISO 9906 – Annex A

ENR4 100-400 MEI > 0.40

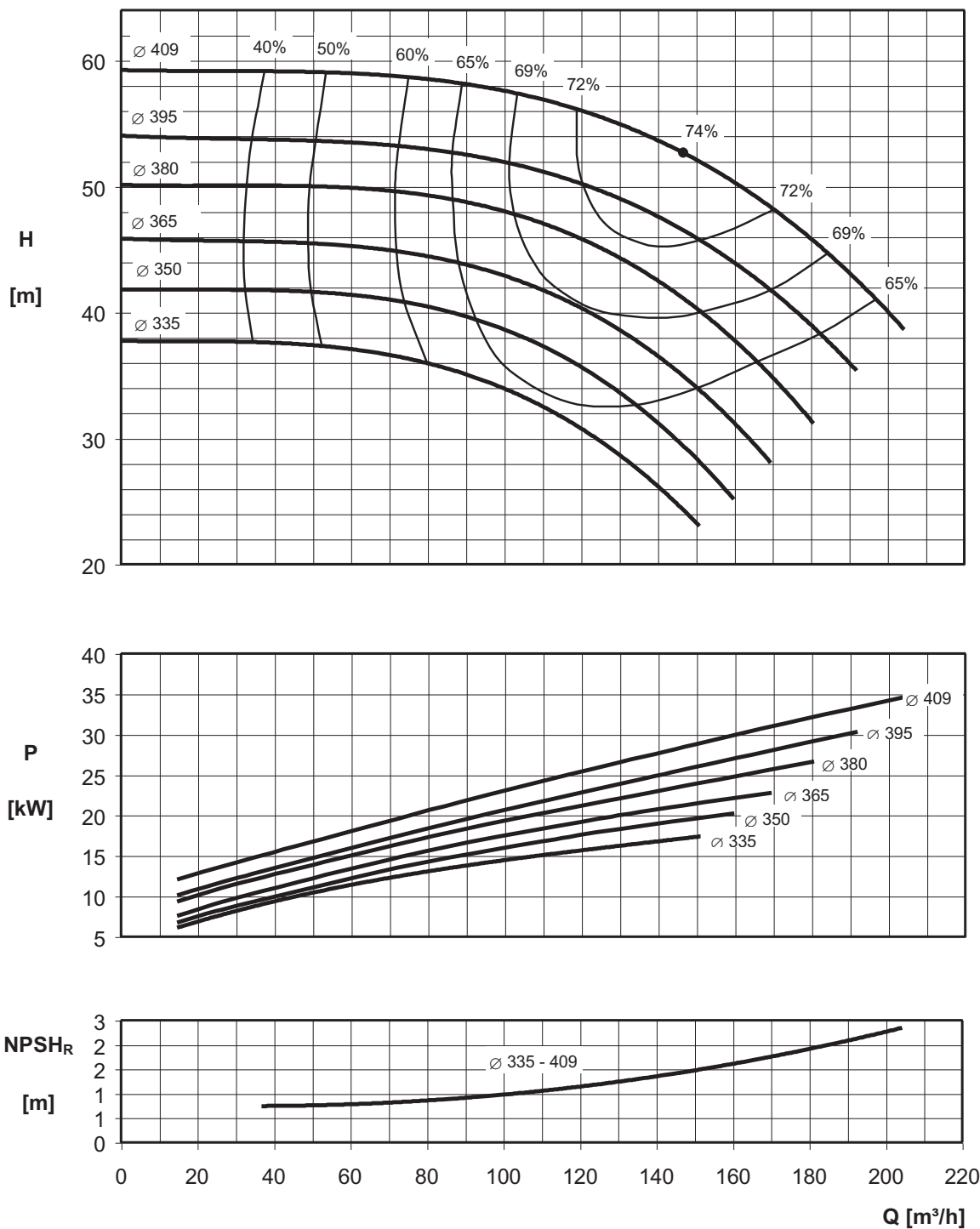

Rotation speed $\approx 1450 \text{ min}^{-1}$
Test standard: ISO 9906 – Annex A

ENR4 125-200 MEI > 0.40

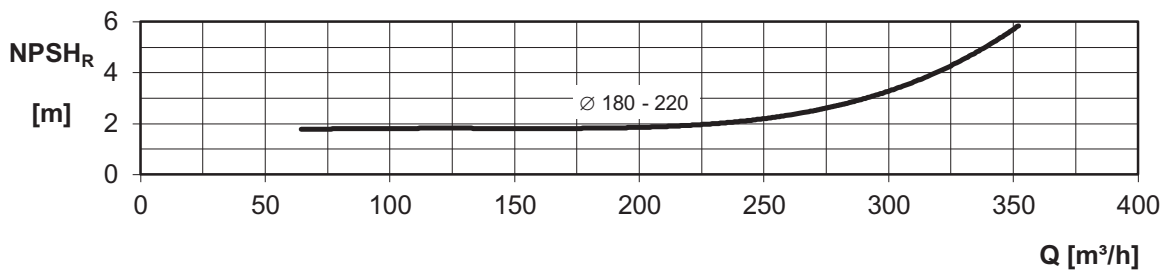
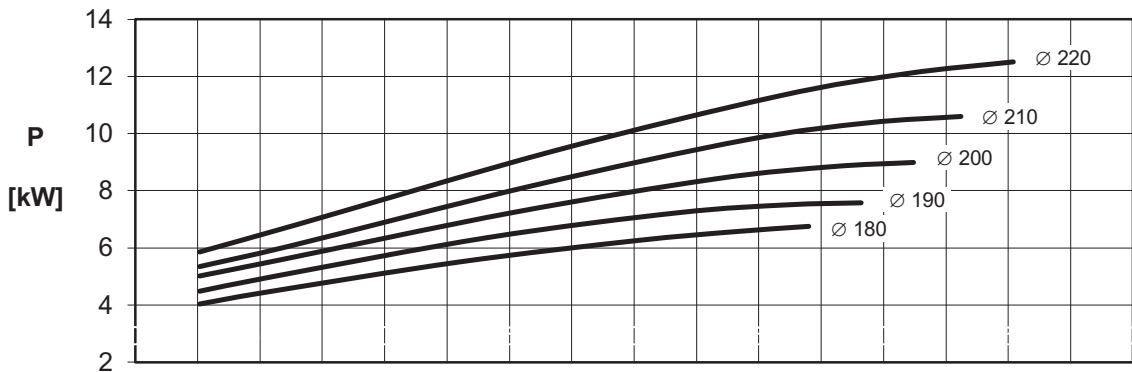
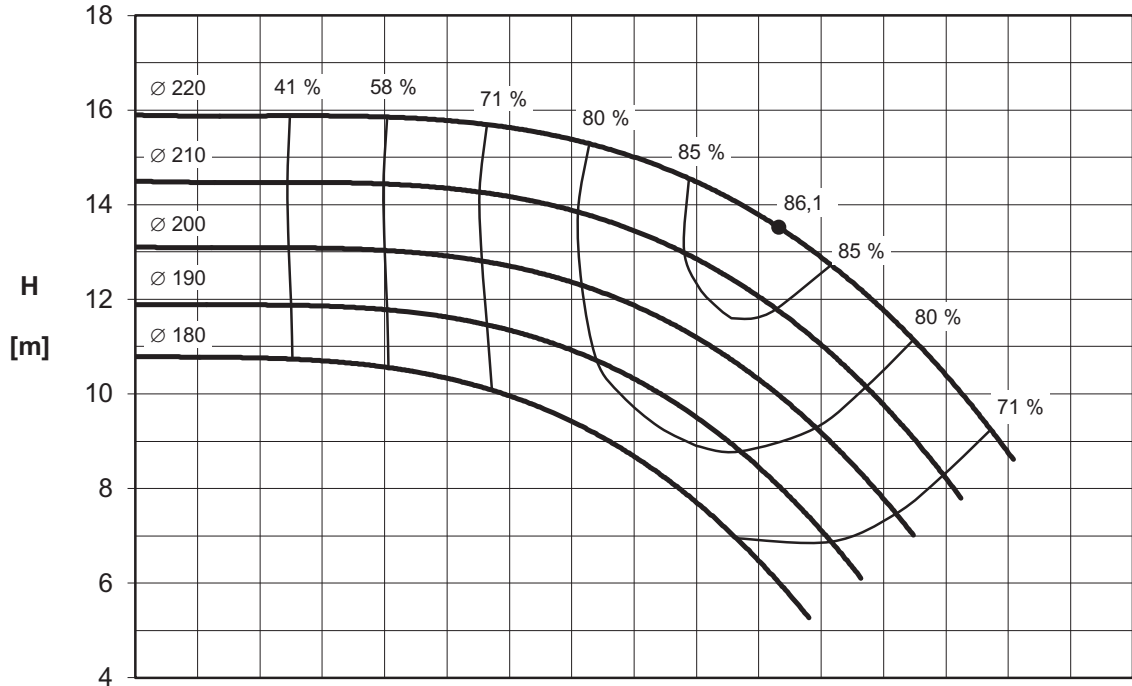

Rotation speed $\approx 1450 \text{ min}^{-1}$
Test standard: ISO 9906 – Annex A

ENR4 125-250 MEI > 0.40

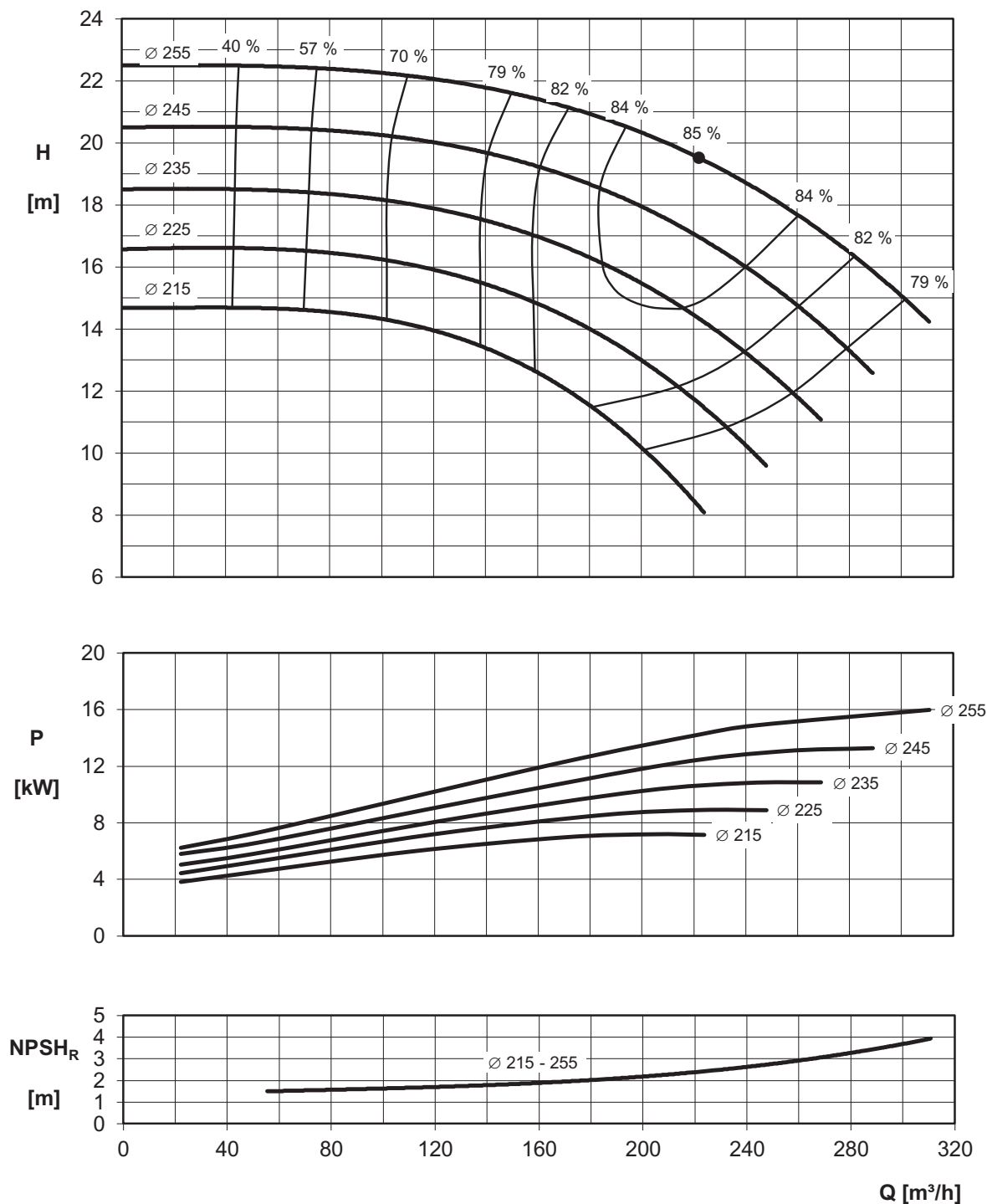

Rotation speed $\approx 1450 \text{ min}^{-1}$
Test standard: ISO 9906 – Annex A

ENR4 125-315 MEI > 0.40

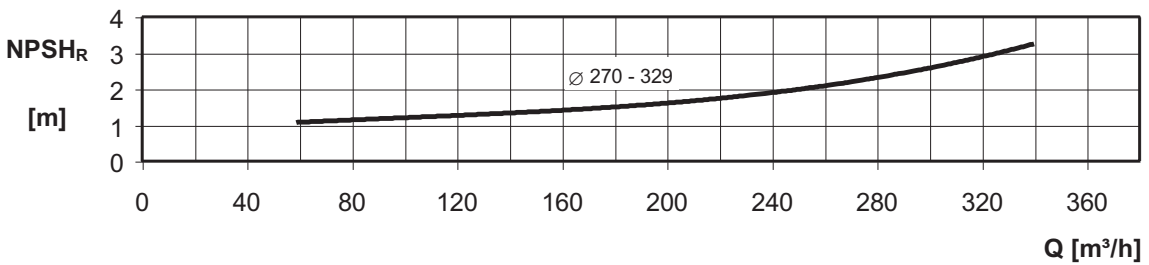
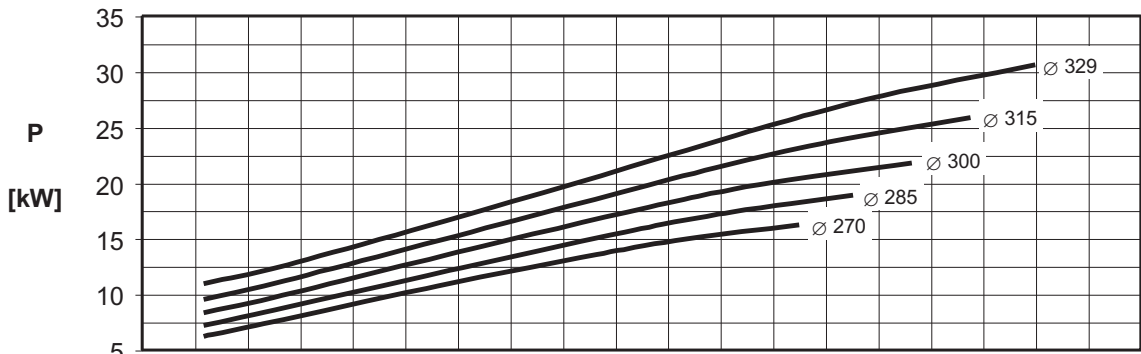
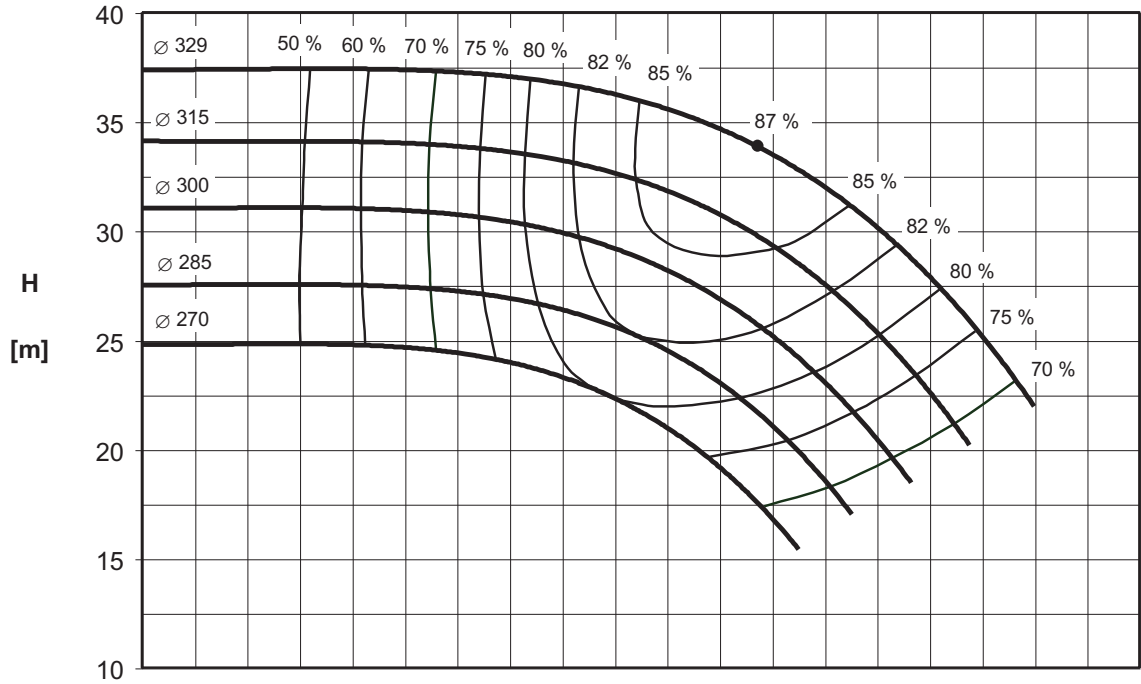

Rotation speed $\approx 1450 \text{ min}^{-1}$
Test standard: ISO 9906 – Annex A

ENR4 125-400 MEI > 0.40

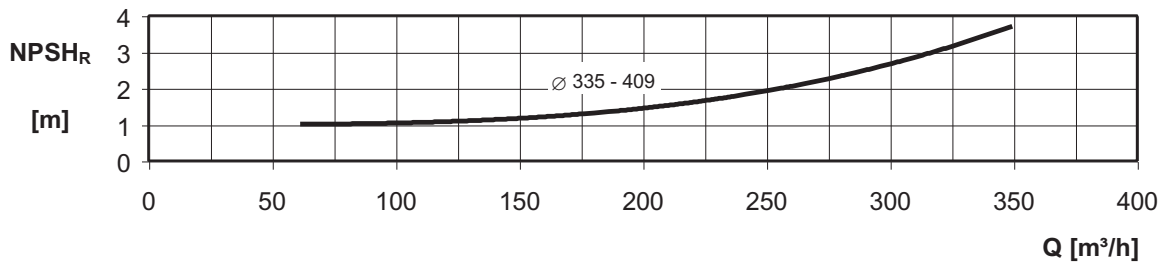
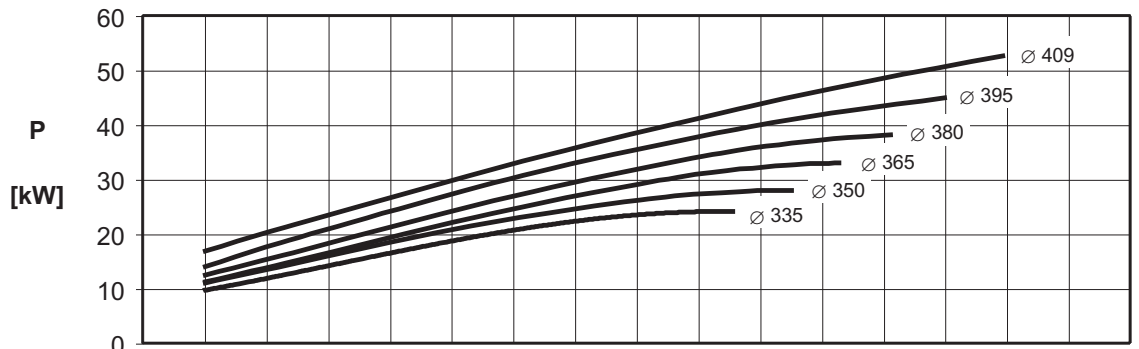
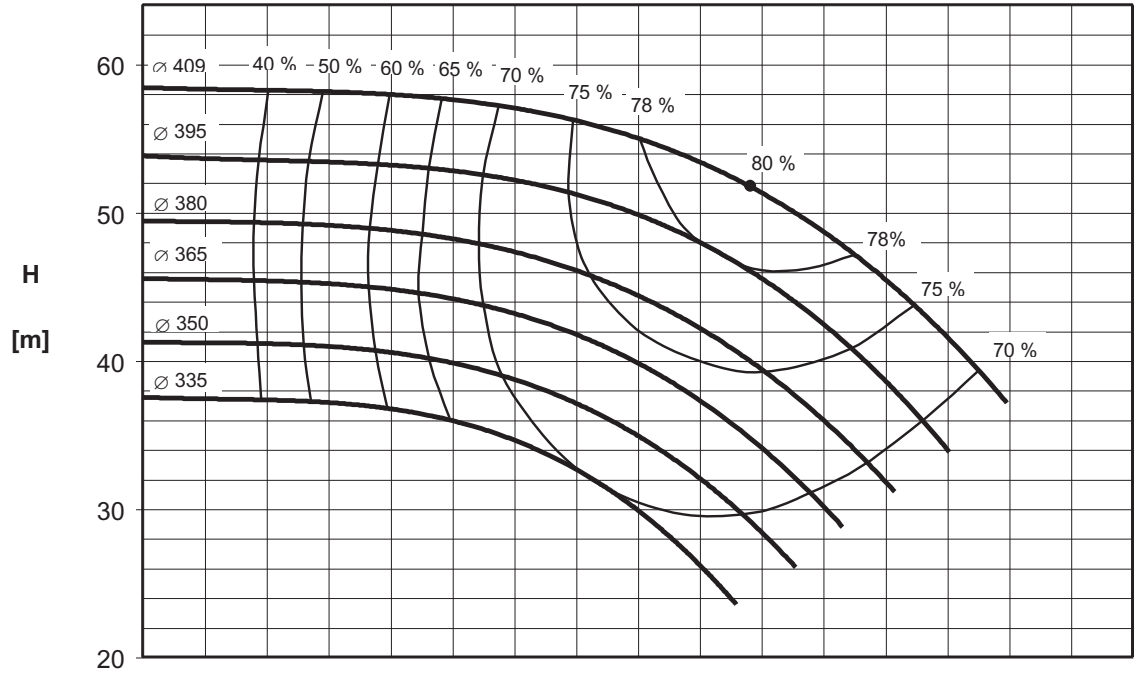

Rotation speed $\approx 1450 \text{ min}^{-1}$
Test standard: ISO 9906 – Annex A

ENR4 150-200 MEI > 0.40

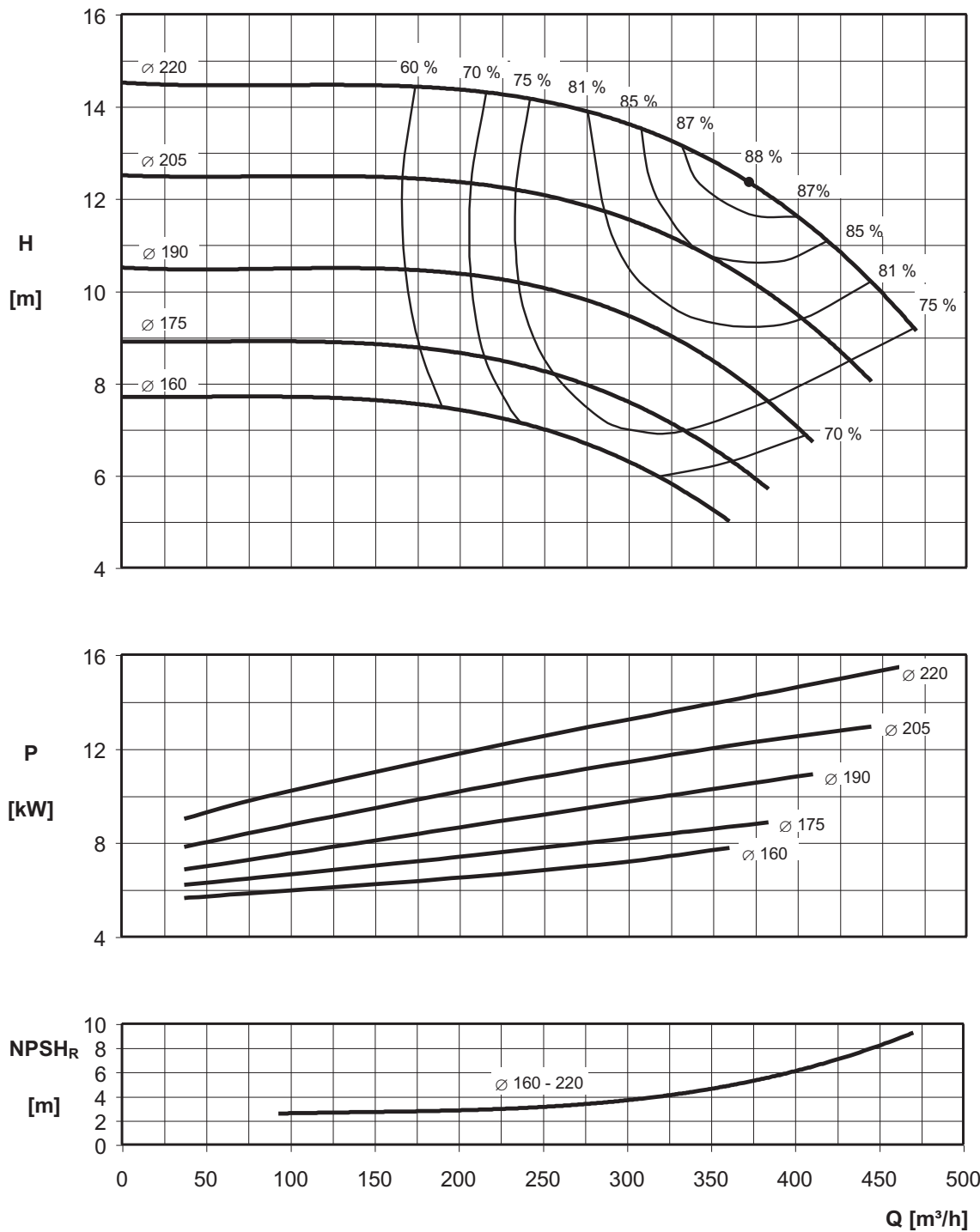

Rotation speed $\approx 1450 \text{ min}^{-1}$
Test standard: ISO 9906 – Annex A

ENR4 150-250 MEI > 0.40

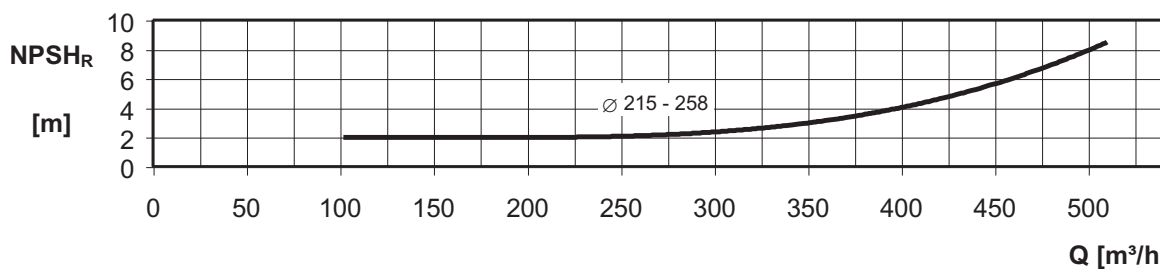
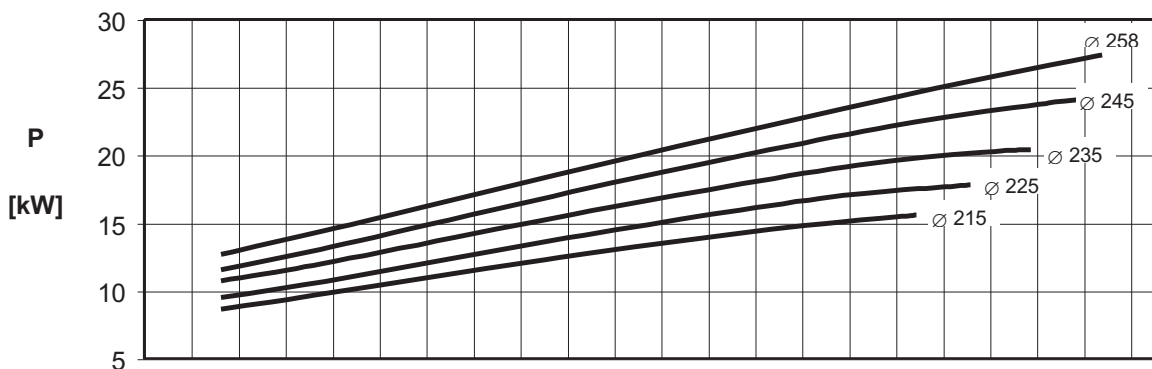
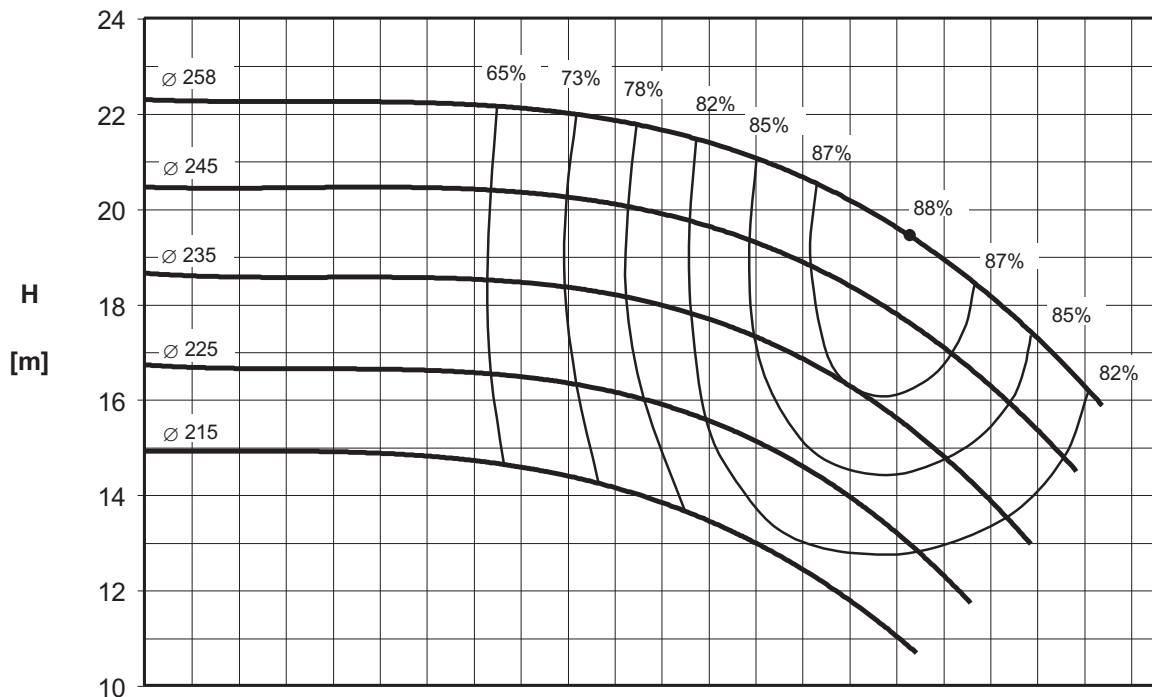

Rotation speed $\approx 1450 \text{ min}^{-1}$
Test standard: ISO 9906 – Annex A

ENR4 150-315 MEI > 0.40

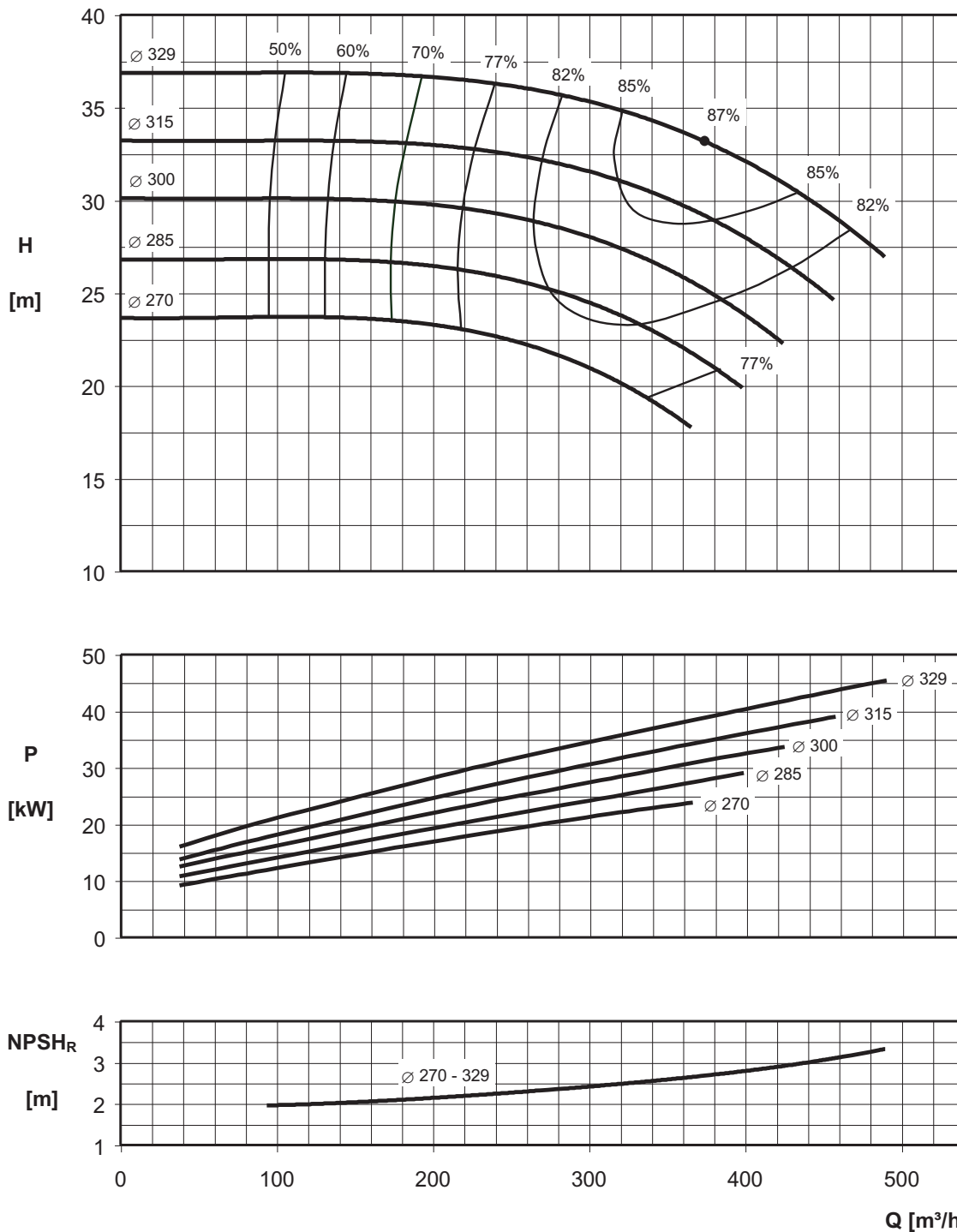

Rotation speed $\approx 1450 \text{ min}^{-1}$
Test standard: ISO 9906 – Annex A

ENR4 150-400 MEI > 0.40

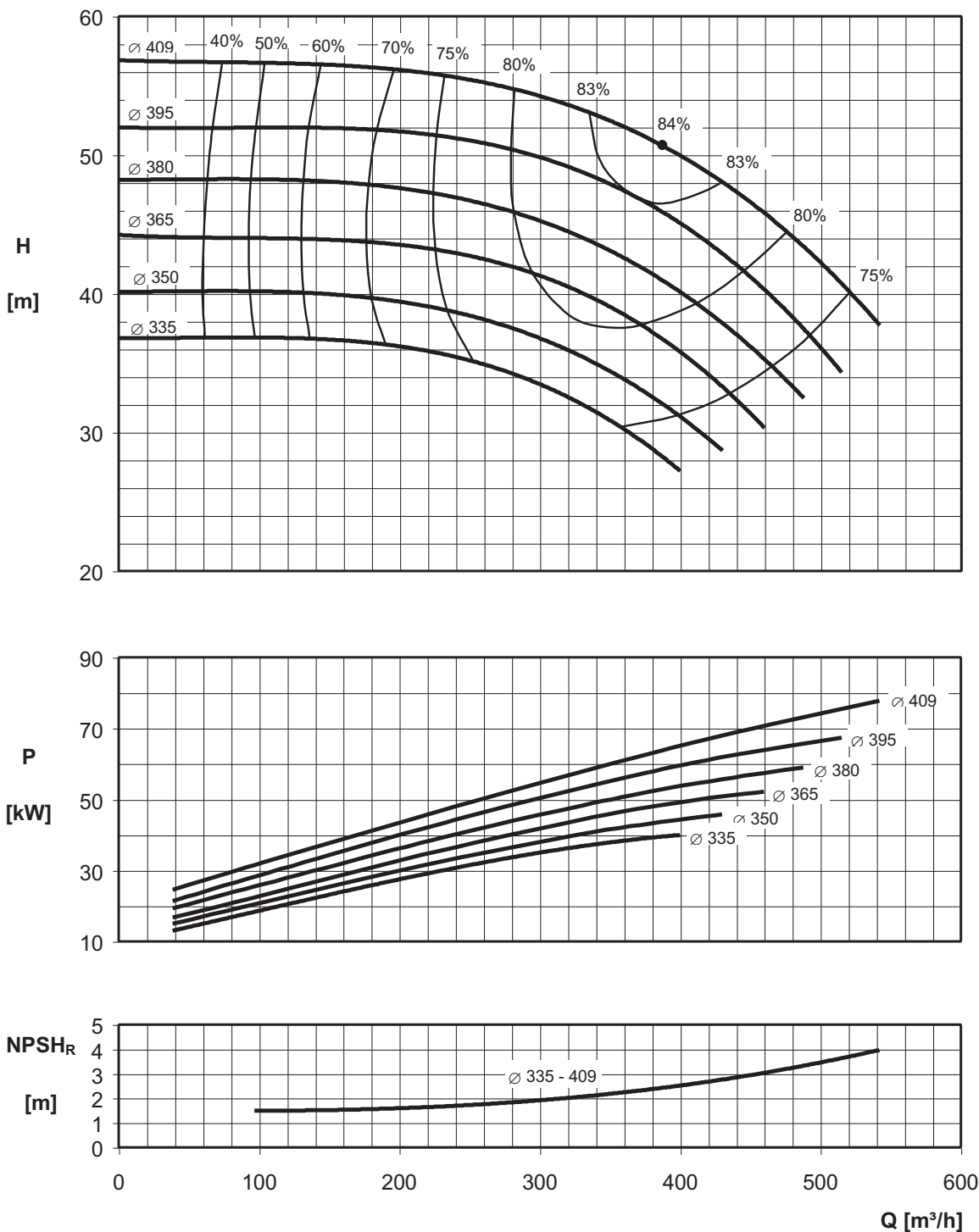

Rotation speed $\approx 1450 \text{ min}^{-1}$
Test standard: ISO 9906 – Annex A

ENR4 150-500 MEI > 0.40

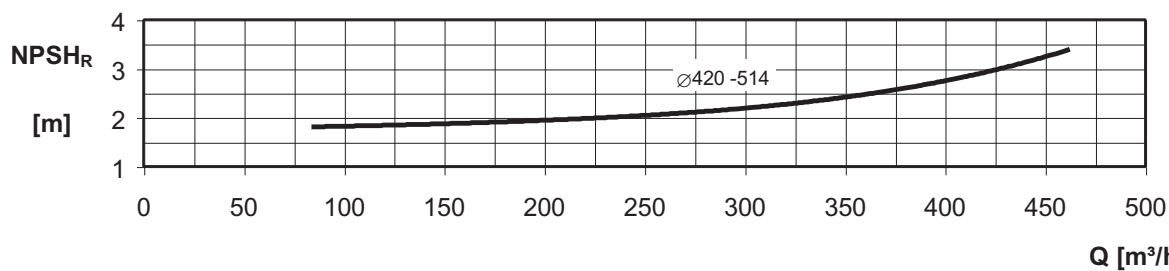
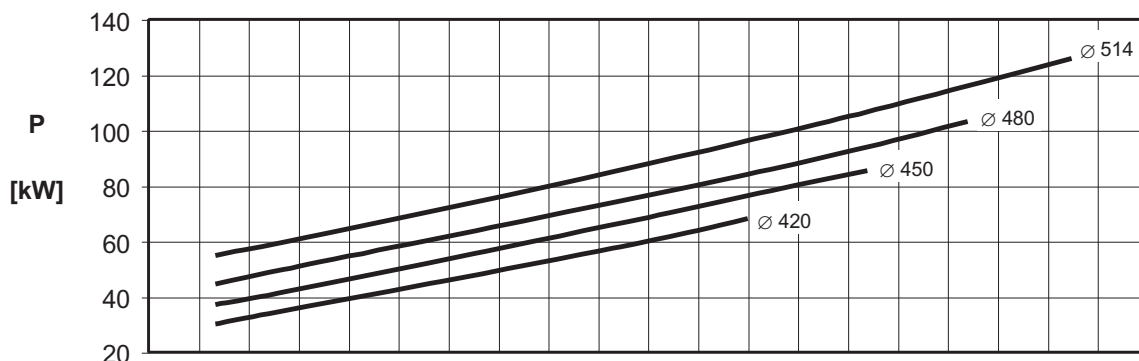
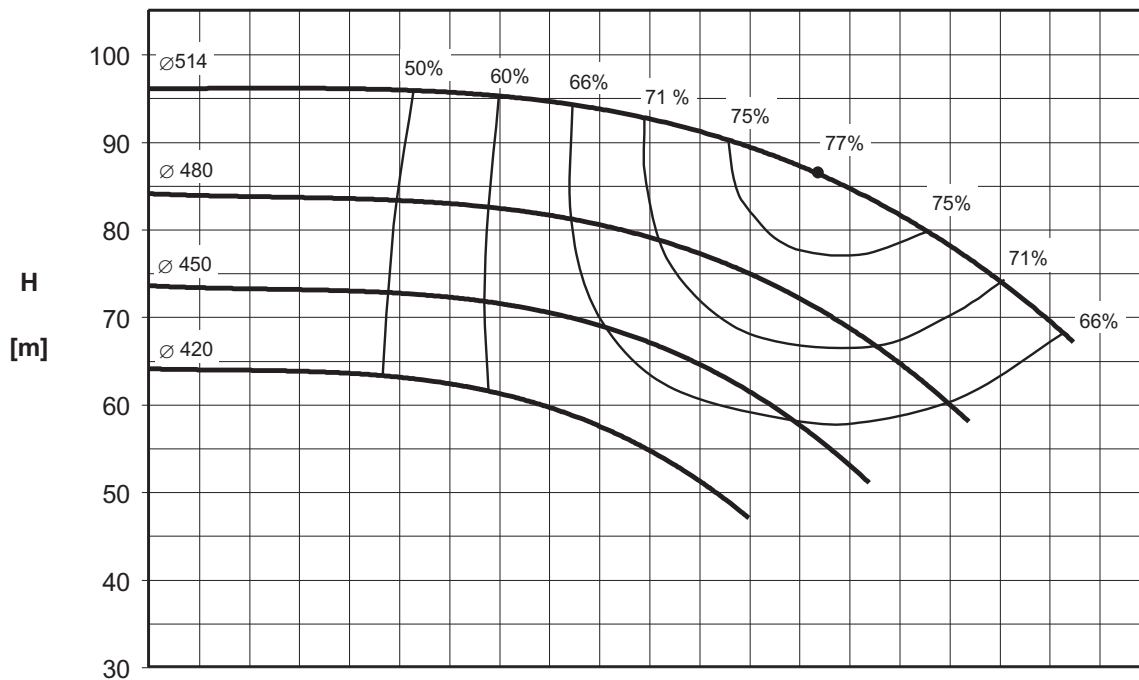

Rotation speed $\approx 1450 \text{ min}^{-1}$
Test standard: ISO 9906 – Annex A

ENR4 200-250 MEI > 0.40

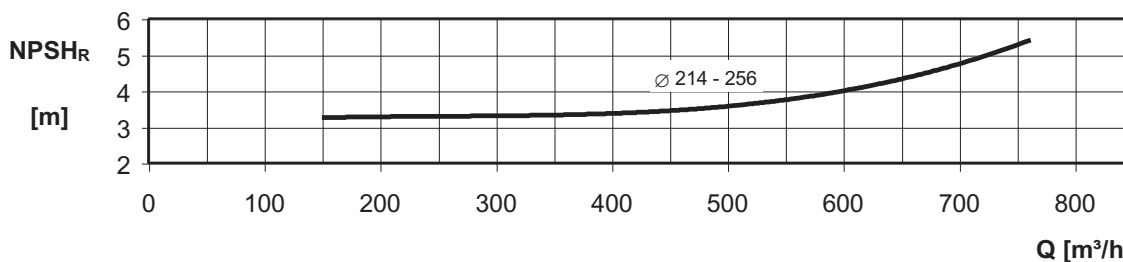
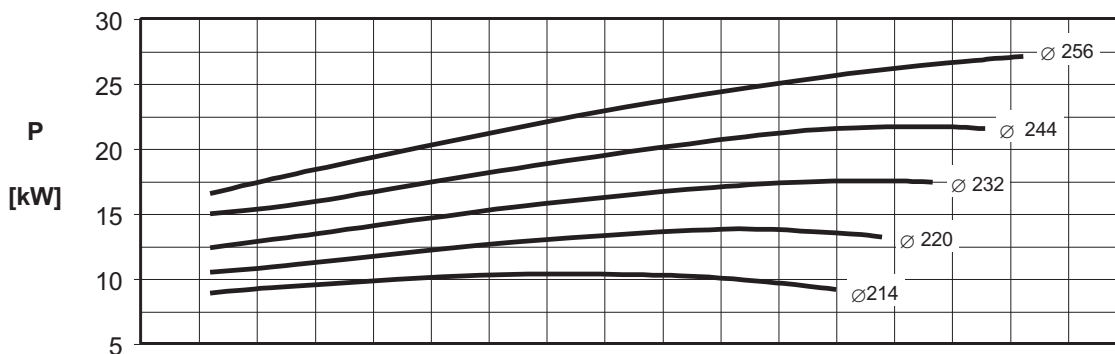
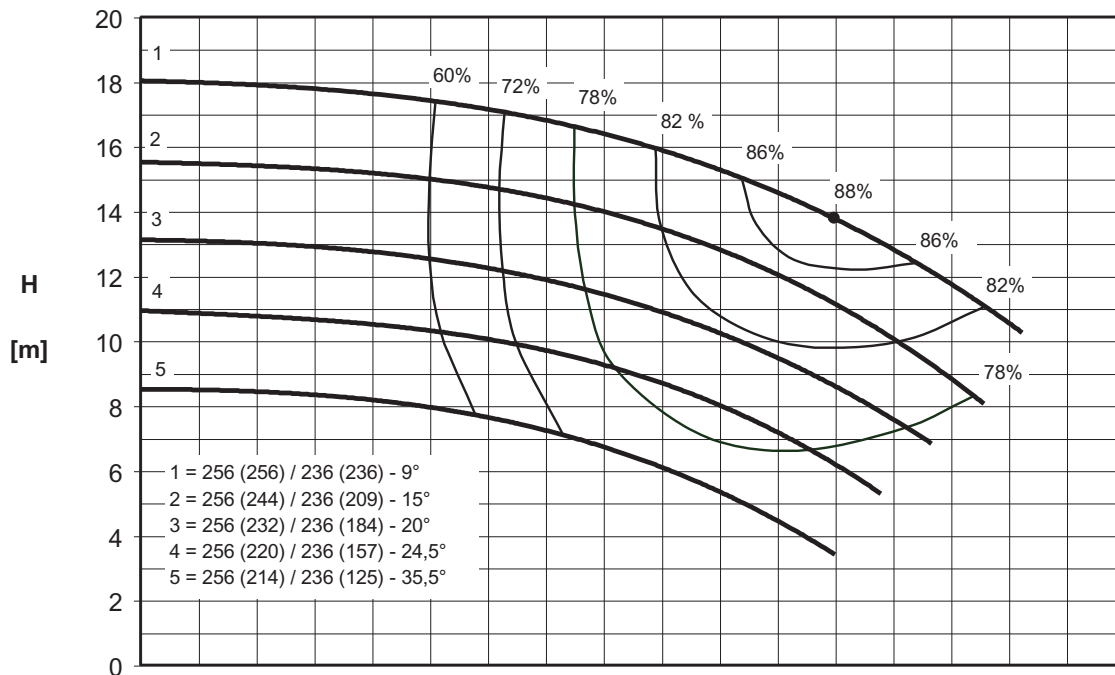

Rotation speed $\approx 1450 \text{ min}^{-1}$
Test standard: ISO 9906 – Annex A

SECTIONAL VIEW

25 – 35 – 45

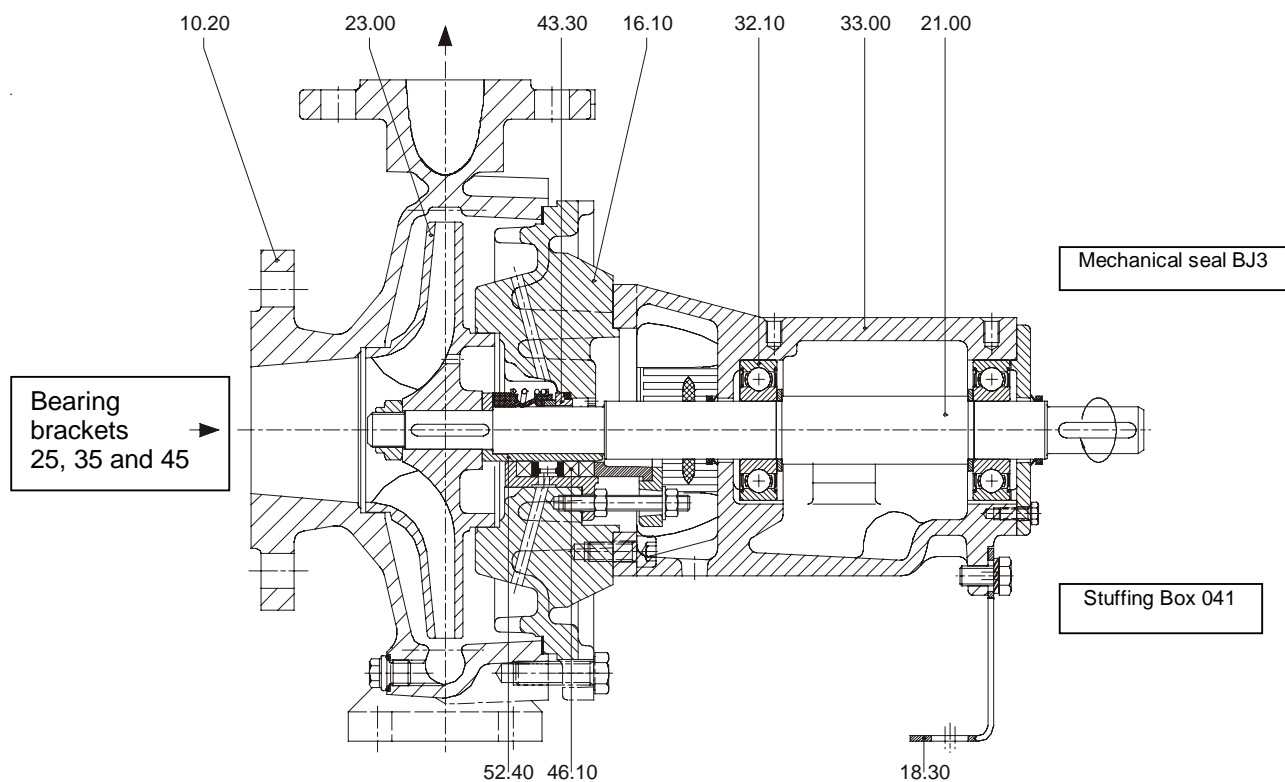

N°	PART NAME
10.20	volute casing
16.10	casing cover
18.30	support foot
21.00	shaft
23.00	impeller
32.10	ball bearing
33.00	bearing bracket
43.30	mechanical seal
46.10	stuffing box
52.40	shaft sleeve (stuffing box)

PUMP

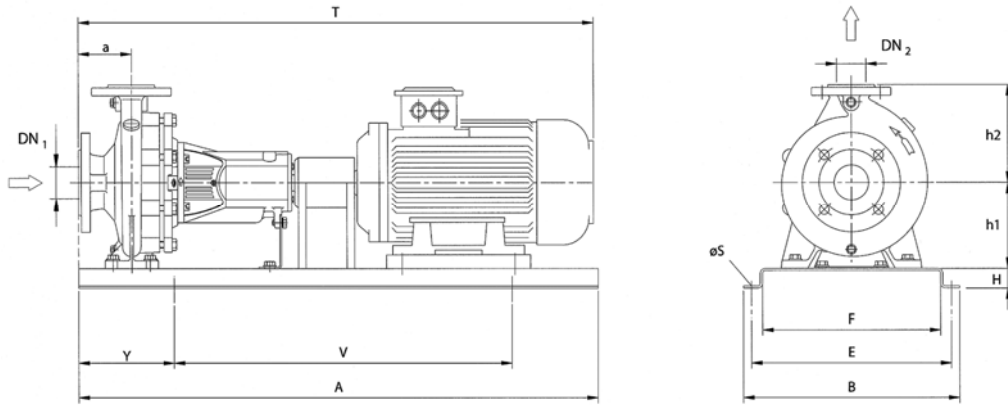

Dimension table 32 - 40 - 50

Model	Motor		Dimensions [mm]															[kgf]
	[Kw]	MEC	DN2	DN1	a	h2	h1	A	B	F	Y	V	E	H	S	T		
ENR 32-125	0,37	71	32	50	80	140	112	900	390	300	150	600	350	50	18	714	70,0	
ENR 32-125	0,55	80	32	50	80	140	112	900	390	300	150	600	350	50	18	714	70,0	
ENR 32-125	0,75	80	32	50	80	140	112	900	390	300	150	600	350	50	18	714	70,0	
ENR 32-160	0,37	71	32	50	80	160	132	900	390	300	150	600	350	50	18	714	71,0	
ENR 32-160	0,55	80	32	50	80	160	132	900	390	300	150	600	350	50	18	714	71,0	
ENR 32-160	0,75	80	32	50	80	160	132	900	390	300	150	600	350	50	18	714	71,0	
ENR 32-200	0,55	80	32	50	80	180	160	900	390	300	150	600	350	50	18	714	79,0	
ENR 32-200	0,75	80	32	50	80	180	160	900	390	300	150	600	350	50	18	714	79,0	
ENR 32-200	1,1	90S	32	50	80	180	160	900	390	300	150	600	350	50	18	764	82,0	
ENR 32-200	1,5	90L	32	50	80	180	160	900	390	300	150	600	350	50	18	764	84,0	
ENR 32-250	0,75	80	32	50	100	225	180	900	490	380	150	600	440	50	18	734	95,0	
ENR 32-250	1,1	90S	32	50	100	225	180	900	490	380	150	600	440	50	18	784	98,0	
ENR 32-250	1,5	90L	32	50	100	225	180	900	490	380	150	600	440	50	18	784	100,0	
ENR 32-250	2,2	100L	32	50	100	225	180	900	490	380	150	600	440	50	18	864	111,0	
ENR 32-250	3	100L	32	50	100	225	180	900	490	380	150	600	440	50	18	864	111,0	
ENR 40-125	0,37	71	40	65	80	140	112	900	390	300	150	600	350	50	18	714	71,0	
ENR 40-125	0,55	80	40	65	80	140	112	900	390	300	150	600	350	50	18	714	71,0	
ENR 40-125	0,75	80	40	65	80	140	112	900	390	300	150	600	350	50	18	714	71,0	
ENR 40-160	0,37	71	40	65	80	160	132	900	390	300	150	600	350	50	18	714	77,0	
ENR 40-160	0,55	80	40	65	80	160	132	900	390	300	150	600	350	50	18	714	77,0	
ENR 40-160	0,75	80	40	65	80	160	132	900	390	300	150	600	350	50	18	714	77,0	
ENR 40-160	1,1	90S	40	65	80	160	132	900	390	300	150	600	350	50	18	764	80,0	
ENR 40-160	1,5	90L	40	65	80	160	132	900	390	300	150	600	350	50	18	764	82,0	
ENR 40-200	0,55	80	40	65	100	180	160	900	490	380	150	600	440	50	18	734	84,0	
ENR 40-200	0,75	80	40	65	100	180	160	900	490	380	150	600	440	50	18	734	84,0	
ENR 40-200	1,1	90S	40	65	100	180	160	900	490	380	150	600	440	50	18	784	87,0	
ENR 40-200	1,5	90L	40	65	100	180	160	900	490	380	150	600	440	50	18	784	89,0	
ENR 40-250	1,1	90S	40	65	100	225	180	900	490	380	150	600	440	50	18	784	98,0	
ENR 40-250	1,5	90L	40	65	100	225	180	900	490	380	150	600	440	50	18	784	100,0	
ENR 40-250	2,2	100L	40	65	100	225	180	900	490	380	150	600	440	50	18	864	111,0	
ENR 40-250	3	100L	40	65	100	225	180	900	490	380	150	600	440	50	18	864	111,0	
ENR 40-315	2,2	100L	40	65	125	250	225	1120	610	480	190	740	550	50	22	999	171,0	
ENR 40-315	3	100L	40	65	125	250	225	1120	610	480	190	740	550	50	22	999	171,0	
ENR 40-315	4	112	40	65	125	250	225	1120	610	480	190	740	550	50	22	999	178,0	
ENR 40-315	5,5	132S	40	65	125	250	225	1120	610	480	190	740	550	50	22	1081	189,0	
ENR 50-125	0,37	71	50	65	100	160	132	900	390	300	150	600	350	50	18	734	77,0	
ENR 50-125	0,55	80	50	65	100	160	132	900	390	300	150	600	350	50	18	734	77,0	
ENR 50-125	0,75	80	50	65	100	160	132	900	390	300	150	600	350	50	18	734	77,0	
ENR 50-125	1,1	90S	50	65	100	160	132	900	390	300	150	600	350	50	18	784	80,0	
ENR 50-160	0,55	80	50	65	100	180	160	900	490	380	150	600	440	50	18	734	82,0	
ENR 50-160	0,75	80	50	65	100	180	160	900	490	380	150	600	440	50	18	734	82,0	
ENR 50-160	1,1	90S	50	65	100	180	160	900	490	380	150	600	440	50	18	784	85,0	
ENR 50-160	2,2	100L	50	65	100	180	160	900	490	380	150	600	440	50	18	864	97,0	

DIMENSIONS AND WEIGHT

50Hz

Rev. 0

Dimension table 50 - 65 - 80

Model	Motor		Dimensions [mm]															[kgf]
	[Kw] 4 poles	MEC	DN2	DN1	a	h2	h1	A	B	F	Y	V	E	H	S	T		
ENR 50-200	1,1	90S	50	65	100	200	160	900	490	380	150	600	440	50	18	784	89,0	
ENR 50-200	1,5	90L	50	65	100	200	160	900	490	380	150	600	440	50	18	784	92,0	
ENR 50-200	2,2	100L	50	65	100	200	160	900	490	380	150	600	440	50	18	864	102,0	
ENR 50-200	3	100L	50	65	100	200	160	900	490	380	150	600	440	50	18	864	102,0	
ENR 50-200	4	112	50	65	100	200	160	900	490	380	150	600	440	50	18	864	109,0	
ENR 50-250	1,5	90L	50	65	100	225	180	900	490	380	150	600	440	50	18	784	107,0	
ENR 50-250	2,2	100L	50	65	100	225	180	900	490	380	150	600	440	50	18	864	117,0	
ENR 50-250	3	100L	50	65	100	225	180	900	490	380	150	600	440	50	18	864	117,0	
ENR 50-250	4	112	50	65	100	225	180	900	490	380	150	600	440	50	18	864	123,0	
ENR 50-250	5,5	132S	50	65	100	225	180	900	490	380	150	600	440	50	18	946	138,0	
ENR 50-315	3	100L	50	65	125	280	225	1120	610	480	190	740	550	50	22	999	171,0	
ENR 50-315	4	112	50	65	125	280	225	1120	610	480	190	740	550	50	22	999	178,0	
ENR 50-315	5,5	132S	50	65	125	280	225	1120	610	480	190	740	550	50	22	1081	189,0	
ENR 50-315	7,5	132M	50	65	125	280	225	1120	610	480	190	740	550	50	22	1081	199,0	
ENR 65-125	0,55	80	65	80	100	180	160	900	490	380	150	600	440	50	18	734	80,0	
ENR 65-125	0,75	80	65	80	100	180	160	900	490	380	150	600	440	50	18	734	80,0	
ENR 65-125	1,1	90S	65	80	100	180	160	900	490	380	150	600	440	50	18	784	83,0	
ENR 65-160	0,75	80	65	80	100	200	160	900	490	380	150	600	440	50	18	734	85,0	
ENR 65-160	1,1	90S	65	80	100	200	160	900	490	380	150	600	440	50	18	784	88,0	
ENR 65-160	1,5	90L	65	80	100	200	160	900	490	380	150	600	440	50	18	784	90,0	
ENR 65-160	2,2	100L	65	80	100	200	160	900	490	380	150	600	440	50	18	864	100,0	
ENR 65-200	1,1	90S	65	80	100	225	180	900	490	380	150	600	440	50	18	784	98,0	
ENR 65-200	1,5	90L	65	80	100	225	180	900	490	380	150	600	440	50	18	784	100,0	
ENR 65-200	2,2	100L	65	80	100	225	180	900	490	380	150	600	440	50	18	864	110,0	
ENR 65-200	3	100L	65	80	100	225	180	900	490	380	150	600	440	50	18	864	110,0	
ENR 65-200	4	112	65	80	100	225	180	900	490	380	150	600	440	50	18	864	116,0	
ENR 65-200	5,5	132S	65	80	100	225	180	900	490	380	150	600	440	50	18	946	131,0	
ENR 65-250	2,2	100L	65	80	100	250	200	1120	610	480	190	740	550	50	22	974	163,0	
ENR 65-250	3	100L	65	80	100	250	200	1120	610	480	190	740	550	50	22	974	163,0	
ENR 65-250	4	112	65	80	100	250	200	1120	610	480	190	740	550	50	22	974	169,0	
ENR 65-250	5,5	132S	65	80	100	250	200	1120	610	480	190	740	550	50	22	1056	184,0	
ENR 65-250	7,5	132M	65	80	100	250	200	1120	610	480	190	740	550	50	22	1056	194,0	
ENR 65-315	5,5	132S	65	80	125	280	225	1120	610	480	190	740	550	50	22	1081	203,0	
ENR 65-315	7,5	132M	65	80	125	280	225	1120	610	480	190	740	550	50	22	1081	211,0	
ENR 65-315	11	160M	65	80	125	280	225	1400	610	480	230	940	550	75	26	1247	254,0	
ENR 65-315	15	160L	65	80	125	280	225	1400	610	480	230	940	550	75	26	1247	268,0	
ENR 80-160	0,75	80	80	100	125	225	180	900	490	380	150	600	440	50	18	759	90,0	
ENR 80-160	1,1	90S	80	100	125	225	180	900	490	380	150	600	440	50	18	809	93,0	
ENR 80-160	1,5	90L	80	100	125	225	180	900	490	380	150	600	440	50	18	809	95,0	
ENR 80-160	2,2	100L	80	100	125	225	180	900	490	380	150	600	440	50	18	889	105,0	
ENR 80-160	3	100L	80	100	125	225	180	900	490	380	150	600	440	50	18	889	105,0	
ENR 80-160	4	112	80	100	125	225	180	900	490	380	150	600	440	50	18	889	112,0	
ENR 80-200	2,2	100L	80	100	125	250	180	1120	610	480	190	740	550	50	22	999	152,0	
ENR 80-200	3	100L	80	100	125	250	180	1120	610	480	190	740	550	50	22	999	152,0	
ENR 80-200	4	112	80	100	125	250	180	1120	610	480	190	740	550	50	22	999	159,0	
ENR 80-200	5,5	132S	80	100	125	250	180	1120	610	480	190	740	550	50	22	1081	170,0	
ENR 80-250	3	100L	80	100	125	280	200	1120	610	480	190	740	550	50	22	999	167,0	
ENR 80-250	4	112	80	100	125	280	200	1120	610	480	190	740	550	50	22	999	174,0	
ENR 80-250	5,5	132S	80	100	125	280	200	1120	610	480	190	740	550	50	22	1081	185,0	
ENR 80-250	7,5	132M	80	100	125	280	200	1120	610	480	190	740	550	50	22	1081	193,0	
ENR 80-250	11	160M	80	100	125	280	200	1400	610	480	230	940	550	75	26	1247	236,0	
ENR 80-315	5,5	132S	80	100	125	315	250	1120	610	480	190	740	550	50	22	1081	196,0	
ENR 80-315	7,5	132M	80	100	125	315	250	1120	610	480	190	740	550	50	22	1081	204,0	
ENR 80-315	11	160M	80	100	125	315	250	1400	610	480	230	940	550	75	26	1247	248,0	
ENR 80-315	15	160L	80	100	125	315	250	1400	610	480	230	940	550	75	26	1247	262,0	
ENR 80-315	18,5	180M	80	100	125	315	250	1400	610	480	230	940	550	75	26	1285	286,0	
ENR 80-315	22	180L	80	100	125	315	250	1400	610	480	230	940	550	75	26	1322	325,0	
ENR 80-315	30	200L	80	100	125	315	250	1400	730	600	230	940	670	75	26	1322	364,0	

Dimension table 80 - 100 - 125 - 150

Model	Motor		Dimensions [mm]															[kgf]
	[Kw]	MEC	DN2	DN1	a	h2	h1	A	B	F	Y	V	E	H	S	T		
ENR 80-400	11	160M	80	125	125	355	280	1400	610	480	230	940	550	75	26	1307	356,0	
ENR 80-400	15	160L	80	125	125	355	280	1400	610	480	230	940	550	75	26	1307	369,0	
ENR 80-400	18,5	180M	80	125	125	355	280	1400	610	480	230	940	550	75	26	1345	392,0	
ENR 80-400	22	180L	80	125	125	355	280	1400	610	480	230	940	550	75	26	1382	428,0	
ENR 80-400	30	200L	80	125	125	355	280	1400	730	600	230	940	670	75	26	1382	452,0	
ENR 100-160	2,2	100L	100	125	125	280	200	1120	610	480	190	740	550	50	22	999	155,0	
ENR 100-160	3	100L	100	125	125	280	200	1120	610	480	190	740	550	50	22	999	155,0	
ENR 100-160	4	112	100	125	125	280	200	1120	610	480	190	740	550	50	22	999	162,0	
ENR 100-160	5,5	132S	100	125	125	280	200	1120	610	480	190	740	550	50	22	1081	173,0	
ENR 100-200	2,2	100L	100	125	125	280	200	1120	610	480	190	740	550	50	22	999	159,0	
ENR 100-200	3	100L	100	125	125	280	200	1120	610	480	190	740	550	50	22	999	159,0	
ENR 100-200	4	112	100	125	125	280	200	1120	610	480	190	740	550	50	22	999	165,0	
ENR 100-200	5,5	132S	100	125	125	280	200	1120	610	480	190	740	550	50	22	1081	176,0	
ENR 100-200	7,5	132M	100	125	125	280	200	1120	610	480	190	740	550	50	22	1081	186,0	
ENR 100-250	4	112	100	125	140	280	225	1120	610	480	190	740	550	50	22	1014	190,0	
ENR 100-250	5,5	132S	100	125	140	280	225	1120	610	480	190	740	550	50	22	1096	201,0	
ENR 100-250	7,5	132M	100	125	140	280	225	1120	610	480	190	740	550	50	22	1096	209,0	
ENR 100-250	11	160M	100	125	140	280	225	1400	610	480	230	940	550	75	26	1262	252,0	
ENR 100-250	15	160L	100	125	140	280	225	1400	610	480	230	940	550	75	26	1262	266,0	
ENR 100-315	11	160M	100	125	140	315	250	1400	610	480	230	940	550	75	26	1262	270,0	
ENR 100-315	15	160L	100	125	140	315	250	1400	610	480	230	940	550	75	26	1262	284,0	
ENR 100-315	18,5	180M	100	125	140	315	250	1400	610	480	230	940	550	75	26	1300	309,0	
ENR 100-315	22	180L	100	125	140	315	250	1400	610	480	230	940	550	75	26	1337	347,0	
ENR 100-315	30	200L	100	125	140	315	250	1400	730	600	230	940	670	75	26	1337	386,0	
ENR 100-400	15	160L	100	125	140	355	280	1400	730	600	230	940	670	75	26	1322	373,0	
ENR 100-400	18,5	180M	100	125	140	355	280	1400	730	600	230	940	670	75	26	1360	398,0	
ENR 100-400	22	180L	100	125	140	355	280	1400	730	600	230	940	670	75	26	1397	436,0	
ENR 100-400	30	200L	100	125	140	355	280	1400	730	600	230	940	670	75	26	1397	462,0	
ENR 100-400	37	225S	100	125	140	355	280	1400	730	600	230	940	670	75	26	1504	503,0	
ENR 100-400	45	225M	100	125	140	355	280	1400	730	600	230	940	670	75	26	1504	521,0	
ENR 125-200	7,5	132M	125	150	140	315	250	1120	610	480	190	740	550	50	22	1096	223,0	
ENR 125-200	11	160M	125	150	140	315	250	1400	610	480	230	940	550	75	26	1262	267,0	
ENR 125-200	15	160L	125	150	140	315	250	1400	610	480	230	940	550	75	26	1262	281,0	
ENR 125-250	7,5	132M	125	150	140	355	250	1120	610	480	190	740	550	50	22	1096	237,0	
ENR 125-250	11	160M	125	150	140	355	250	1400	610	480	230	940	550	75	26	1262	281,0	
ENR 125-250	15	160L	125	150	140	355	250	1400	610	480	230	940	550	75	26	1262	295,0	
ENR 125-250	18,5	180M	125	150	140	355	250	1400	610	480	230	940	550	75	26	1300	319,0	
ENR 125-250	22	180L	125	150	140	355	250	1400	610	480	230	940	550	75	26	1337	358,0	
ENR 125-315	15	160L	125	150	140	355	280	1400	730	600	230	940	670	75	26	1322	352,0	
ENR 125-315	18,5	180M	125	150	140	355	280	1400	730	600	230	940	670	75	26	1360	377,0	
ENR 125-315	22	180L	125	150	140	355	280	1400	730	600	230	940	670	75	26	1397	415,0	
ENR 125-315	30	200L	125	150	140	355	280	1400	730	600	230	940	670	75	26	1397	440,0	
ENR 125-315	37	225S	125	150	140	355	280	1400	730	600	230	940	670	75	26	1504	482,0	
ENR 125-400	30	200L	125	150	140	400	315	1400	730	600	230	940	670	75	26	1397	475,0	
ENR 125-400	37	225S	125	150	140	400	315	1400	730	600	230	940	670	75	26	1504	516,0	
ENR 125-400	45	225M	125	150	140	400	315	1400	730	600	230	940	670	75	26	1504	534,0	
ENR 125-400	55	250M	125	150	140	400	315	1800	730	600	300	1200	670	100	26	1569	612,0	
ENR 125-400	75	280S	125	150	140	400	315	1800	850	700	300	1200	780	100	26	1634	733,0	
ENR 150-200	7,5	132M	150	200	160	400	280	1400	730	600	230	940	670	75	26	1116	303,0	
ENR 150-200	11	160M	150	200	160	400	280	1400	730	600	230	940	670	75	26	1282	325,0	
ENR 150-200	15	160L	150	200	160	400	280	1400	730	600	230	940	670	75	26	1282	338,0	
ENR 150-200	18,5	180M	150	200	160	400	280	1400	730	600	230	940	670	75	26	1320	363,0	
ENR 150-250	15	160L	150	200	160	400	280	1400	730	600	230	940	670	75	26	1282	370,0	
ENR 150-250	18,5	180M	150	200	160	400	280	1400	730	600	230	940	670	75	26	1320	395,0	
ENR 150-250	22	180L	150	200	160	400	280	1400	730	600	230	940	670	75	26	1357	433,0	
ENR 150-250	30	200L	150	200	160	400	280	1400	730	600	230	940	670	75	26	1357	459,0	
ENR 150-250	37	225S	150	200	160	400	280	1400	730	600	230	940	670	75	26	1464	500,0	

DIMENSIONS AND WEIGHT

50Hz

Rev. 0

Dimension table 150 - 200

Model	Motor		Dimensions [mm]															[kgf]
	[Kw] 4 poles	MEC	DN2	DN1	a	h2	h1	Standard Coupling										
								A	B	F	Y	V	E	H	S	T		
ENR 150-315	18,5	180M	150	200	160	400	280	1400	730	600	230	940	670	75	26	1380	427,0	
ENR 150-315	22	180L	150	200	160	400	280	1400	730	600	230	940	670	75	26	1417	465,0	
ENR 150-315	30	200L	150	200	160	400	280	1400	730	600	230	940	670	75	26	1417	491,0	
ENR 150-315	37	225S	150	200	160	400	280	1800	730	600	300	1200	670	100	26	1524	567,0	
ENR 150-315	45	225M	150	200	160	400	280	1800	730	600	300	1200	670	100	26	1524	586,0	
ENR 150-315	55	250M	150	200	160	400	280	1800	730	600	300	1200	670	100	26	1589	628,0	
ENR 150-400	45	225M	150	200	160	450	315	1800	730	600	300	1200	670	100	26	1524	605,0	
ENR 150-400	55	250M	150	200	160	450	315	1800	730	600	300	1200	670	100	26	1589	647,0	
ENR 150-400	75	280S	150	200	160	450	315	1800	850	700	300	1200	780	100	26	1654	768,0	
ENR 150-400	90	280M	150	200	160	450	315	1800	850	700	300	1200	780	100	26	1654	837,0	
ENR 200-250	15	160L	200	200	160	400	280	1400	730	600	230	940	670	75	26	1402	425,0	
ENR 200-250	18,5	180M	200	200	160	400	280	1400	730	600	230	940	670	75	26	1440	450,0	
ENR 200-250	22	180L	200	200	160	400	280	1400	730	600	230	940	670	75	26	1477	488,0	
ENR 200-250	30	200L	200	200	160	400	280	1400	730	600	230	940	670	75	26	1477	514,0	

DIMENSIONS AND WEIGHT

50Hz

Rev. 0

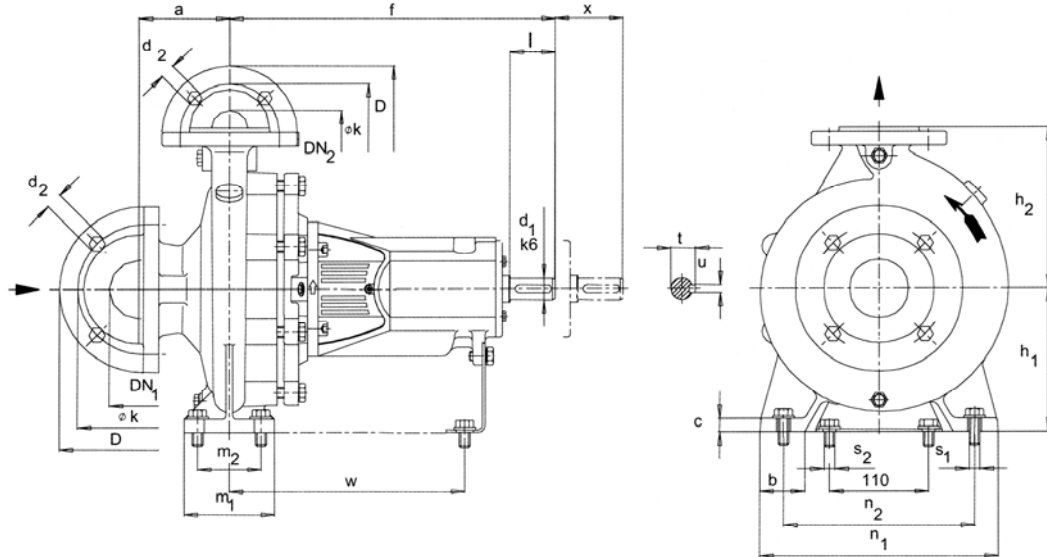

Model	Supp	Dimensions [mm]																				Weight [kgf]
		Pump						Support						Shaft protuberance								
DN2	DN1	a	f	h2	h1	b	c	m1	m2	n1	n2	s1	s2	w	x	d1	l	t	u			
ENR 32-125	25	32	50	80	360	112	140	50	15	100	70	190	140	M12	M12	260	100	24	50	27	8	31,0
ENR 32-160	25	32	50	80	360	132	160	50	15	100	70	240	190	M12	M12	260	100	24	50	27	8	33,0
ENR 32-200	25	32	50	80	360	160	180	50	15	100	70	240	190	M12	M12	260	100	24	50	27	8	34,0
ENR 32-250	25	32	50	100	360	180	225	65	15	125	95	320	250	M12	M12	260	100	24	50	27	8	46,0
ENR 40-125	25	40	65	80	360	112	140	50	15	100	70	210	160	M12	M12	260	100	24	50	27	8	28,0
ENR 40-160	25	40	65	80	360	132	160	50	15	100	70	240	190	M12	M12	260	100	24	50	27	8	30,0
ENR 40-200	25	40	65	100	360	160	180	50	15	100	70	265	212	M12	M12	260	100	24	50	27	8	36,0
ENR 40-250	25	40	65	100	360	180	225	65	15	125	95	320	250	M12	M12	260	100	24	50	27	8	46,0
ENR 40-315	35	40	65	125	470	225	250	65	18	125	95	345	280	M12	M12	340	100	32	80	35	10	73,0
ENR 50-125	25	50	65	100	360	132	160	50	15	100	70	240	190	M12	M12	260	100	24	50	27	8	30,0
ENR 50-160	25	50	65	100	360	160	180	50	15	100	70	265	212	M12	M12	260	100	24	50	27	8	36,0
ENR 50-200	25	50	65	100	360	160	200	50	15	100	70	265	212	M12	M12	260	100	24	50	27	8	40,0
ENR 50-250	25	50	65	100	360	180	225	65	15	125	95	320	250	M12	M12	260	100	24	50	27	8	50,0
ENR 50-315	35	50	65	125	470	225	280	65	17	125	95	345	280	M12	M12	340	100	32	80	35	10	88,0
ENR 65-125	25	65	80	100	360	160	180	65	15	125	95	280	212	M12	M12	260	100	24	50	27	8	33,0
ENR 65-160	25	65	80	100	360	160	200	65	15	125	95	280	212	M12	M12	260	100	24	50	27	8	39,0
ENR 65-200	25	65	80	100	360	180	225	65	15	125	95	320	250	M12	M12	260	140	24	50	27	8	45,0
ENR 65-250	35	65	80	100	470	200	250	80	15	160	120	360	280	M16	M12	340	140	32	80	35	10	70,0
ENR 65-315	35	65	80	125	470	225	280	80	18	160	120	400	315	M16	M12	340	140	32	80	35	10	92,0
ENR 80-160	25	80	100	125	360	180	225	65	15	125	95	320	250	M12	M12	260	140	24	50	27	8	43,0
ENR 80-200	35	80	100	125	470	180	250	65	15	125	95	345	280	M12	M12	340	140	32	80	35	10	60,0
ENR 80-250	35	80	100	125	470	200	280	80	18	160	120	400	315	M16	M12	340	140	32	80	35	10	75,0
ENR 80-315	35	80	100	125	470	250	315	80	18	160	120	400	315	M16	M12	340	140	32	80	35	10	95,0
ENR 80-400	45	80	125	125	530	280	355	80	18	160	120	435	355	M16	M12	370	140	42	110	45	12	143,0
ENR 100-160	35	100	125	125	470	200	280	80	18	160	120	360	280	M16	M12	340	140	32	80	35	10	78,0
ENR 100-200	35	100	125	125	470	200	280	80	18	160	120	360	280	M16	M12	340	140	32	80	35	10	70,0
ENR 100-250	35	100	125	140	470	225	280	80	18	160	120	400	315	M16	M12	340	140	32	80	35	10	85,0
ENR 100-315	35	100	125	140	470	250	315	80	18	160	120	400	315	M16	M12	340	140	32	80	35	10	104,0
ENR 100-400	45	100	125	140	530	280	355	100	18	200	150	500	400	M20	M12	370	140	42	110	45	12	177,0
ENR 125-200	35	125	150	140	470	250	315	80	18	160	120	400	315	M16	M12	340	140	32	80	35	10	100,0
ENR 125-250	35	125	150	140	470	250	355	80	18	160	120	400	315	M16	M12	340	140	32	80	35	10	102,0
ENR 125-315	45	125	150	140	530	280	355	100	18	200	150	500	400	M20	M12	370	140	42	110	45	12	151,0
ENR 125-400	45	125	150	140	530	315	400	100	18	200	150	500	400	M20	M12	370	140	42	110	45	12	188,0
ENR 150-200	35	150	200	160	470	280	400	100	20	200	150	550	450	M20	M12	340	140	32	80	35	10	123,0
ENR 150-250	35	150	200	160	470	280	400	100	20	200	150	500	400	M20	M12	340	140	32	80	35	10	128,0
ENR 150-315	45	150	200	160	530	280	400	100	18	200	150	550	450	M20	M12	370	140	42	110	45	12	170,0
ENR 150-400	45	150	200	160	530	315	450	100	18	200	150	550	450	M20	M12	370	140	42	110	45	12	205,0
ENR 200-250	45	200	200	160	590	280	400	100	22	200	150	500	400	M20	M12	430	180	42	110	45	12	230,0

MOTOR DATA 32 - 40 - 50 Version

Pump type Three Phase	Power		Efficiency Three Phase	Efficiency (% Three phase η %)			Input [kW]	Full load current [A]			Locked rotor current [A]		
	[kW]	[HP]		50%	75%	100%		230 V	400 V	690 V	230 V	400 V	690 V
ENR 32-125/0,37	0,37	0,5	IE1	60,0	63,0	67,0	0,56	2,1	1,2	-	8,5	4,9	-
ENR 32-125/0,55	0,55	0,8	IE1	67,0	69,0	70,0	0,80	2,8	1,6	-	11,6	6,7	-
ENR 32-125/0,75	0,75	1	IE2	79,2	80,3	80,2	0,95	3,12	1,8	1,0	17,1	9,9	5,7
ENR 32-160/0,37	0,37	0,5	IE1	60,0	63,0	67,0	0,56	2,1	1,2	-	8,5	4,9	-
ENR 32-160/0,55	0,55	0,8	IE1	67,0	69,0	70,0	0,80	2,8	1,6	-	11,6	6,7	-
ENR 32-160/0,75	0,75	1	IE2	79,2	80,3	80,2	0,95	3,12	1,8	1,0	17,1	9,9	5,7
ENR 32-200/0,55	0,55	0,8	IE1	67,0	69,0	70,0	0,80	2,8	1,6	-	11,6	6,7	-
ENR 32-200/0,75	0,75	1	IE2	79,2	80,3	80,2	0,97	3,12	1,8	0,0	17,1	9,9	0,0
ENR 32-200/1,1	1,1	1,5	IE2	81,4	82,7	82,5	1,33	4,33	2,5	1,4	26,4	15,3	8,8
ENR 32-200/1,5	1,5	2	IE2	81,0	83,5	83,0	1,81	5,89	3,4	2,0	46,5	26,9	15,5
ENR 32-250/0,75	0,75	1	IE2	79,2	80,3	80,2	0,95	3,12	1,8	1,0	17,1	9,9	5,7
ENR 32-250/1,1	1,1	1,5	IE2	81,4	82,7	82,5	1,33	4,33	2,5	1,4	26,4	15,3	8,8
ENR 32-250/1,5	1,5	2	IE2	81,0	83,5	83,0	1,81	5,89	3,4	2,0	46,5	26,9	15,5
ENR 32-250/2,2	2,2	3	IE2	84,0	85,3	85,1	2,61	8,83	5,1	2,9	53,0	30,6	17,7
ENR 32-250/3	3	4	IE2	82,6	84,7	86,4	3,47	11,26	6,5	3,8	95,7	55,3	31,9
ENR 40-125/0,37	0,37	0,5	IE1	60,0	63,0	67,0	0,56	2,1	1,2	-	8,5	4,9	-
ENR 40-125/0,55	0,55	0,8	IE1	67,0	69,0	70,0	0,80	2,8	1,6	-	11,6	6,7	-
ENR 40-125/0,75	0,75	1	IE2	79,2	80,3	80,2	0,95	3,12	1,8	1,0	17,1	9,9	5,7
ENR 40-160/0,37	0,37	0,5	IE1	60,0	63,0	67,0	0,56	2,1	1,2	-	8,5	4,9	-
ENR 40-160/0,55	0,55	0,8	IE1	67,0	69,0	70,0	0,80	2,8	1,6	-	11,6	6,7	-
ENR 40-160/0,75	0,75	1	IE2	79,2	80,3	80,2	0,95	3,12	1,8	1,0	17,1	9,9	5,7
ENR 40-160/1,1	1,1	1,5	IE2	81,4	82,7	82,5	1,33	4,33	2,5	1,4	26,4	15,3	8,8
ENR 40-160/1,5	1,5	2	IE2	81,0	83,5	83,0	1,81	5,89	3,4	2,0	46,5	26,9	15,5
ENR 40-200/0,55	0,55	0,8	IE1	67,0	69,0	70,0	0,80	2,8	1,6	-	11,6	6,7	-
ENR 40-200/0,75	0,75	1	IE2	79,2	80,3	80,2	0,95	3,12	1,8	1,0	17,1	9,9	5,7
ENR 40-200/1,1	1,1	1,5	IE2	81,4	82,7	82,5	1,33	4,33	2,5	1,4	26,4	15,3	8,8
ENR 40-200/1,5	1,5	2	IE2	81,0	83,5	83,0	1,81	5,89	3,4	2,0	46,5	26,9	15,5
ENR 40-250/1,1	1,1	1,5	IE2	81,4	82,7	82,5	1,33	4,33	2,5	1,4	26,4	15,3	8,8
ENR 40-250/1,5	1,5	2	IE2	81,0	83,5	83,0	1,81	5,89	3,4	2,0	46,5	26,9	15,5
ENR 40-250/2,2	2,2	3	IE2	84,0	85,3	85,1	2,61	8,83	5,1	2,9	53,0	30,6	17,7
ENR 40-250/3	3	4	IE2	82,6	84,7	86,4	3,47	11,26	6,5	3,8	95,7	55,3	31,9
ENR 40-315/2,2	2,2	3	IE2	84,0	85,3	85,1	2,61	8,83	5,1	2,9	53,0	30,6	17,7
ENR 40-315/3	3	4	IE2	82,6	84,7	86,4	3,47	11,26	6,5	3,8	95,7	55,3	31,9
ENR 40-315/4	4	5,5	IE2	82,6	84,7	86,4	4,59	14,72	8,5	4,9	89,8	51,9	29,9
ENR 40-315/5,5	5,5	7,5	IE2	86,0	87,3	87,1	6,16	19,75	11,4	6,6	146,1	84,4	48,7
ENR 50-125/0,37	0,37	0,5	IE1	60,0	63,0	67,0	0,56	2,1	1,2	-	8,5	4,9	-
ENR 50-125/0,55	0,55	0,8	IE1	67,0	69,0	70,0	0,80	2,8	1,6	-	11,6	6,7	-
ENR 50-125/0,75	0,75	1	IE2	79,2	80,3	80,2	0,95	3,12	1,8	1,0	17,1	9,9	5,7
ENR 50-125/1,1	1,1	1,5	IE2	81,4	82,7	82,5	1,33	4,33	2,5	1,4	26,4	15,3	8,8
ENR 50-160/0,55	0,55	0,8	IE1	67,0	69,0	70,0	0,80	2,8	1,6	-	11,6	6,7	-
ENR 50-160/0,75	0,75	1	IE2	79,2	80,3	80,2	0,95	3,12	1,8	1,0	17,1	9,9	5,7
ENR 50-160/1,1	1,1	1,5	IE2	81,4	82,7	82,5	1,33	4,33	2,5	1,4	26,4	15,3	8,8
ENR 50-160/2,2	2,2	3	IE2	84,0	85,3	85,1	2,61	8,83	5,1	2,9	53,0	30,6	17,7
ENR 50-200/1,1	1,1	1,5	IE2	81,4	82,7	82,5	1,33	4,33	2,5	1,4	26,4	15,3	8,8
ENR 50-200/1,5	1,5	2	IE2	81,0	83,5	83,0	1,81	5,89	3,4	2,0	46,5	26,9	15,5
ENR 50-200/2,2	2,2	3	IE2	84,0	85,3	85,1	2,61	8,83	5,1	2,9	53,0	30,6	17,7
ENR 50-200/3	3	4	IE2	82,6	84,7	86,4	3,47	11,26	6,5	3,8	95,7	55,3	31,9
ENR 50-200/4	4	5,5	IE2	82,6	84,7	86,4	4,59	14,72	8,5	4,9	89,8	51,9	29,9

TECHNICAL DATA

50Hz

Rev. 0

MOTOR DATA 50 - 65 - 80 Version

Pump type Three Phase	Power		Efficiency Three Phase	Efficiency (%) Three phase η %			Input [kW]	Full load current [A]			Locked rotor current [A]		
	[kW]	[HP]		50%	75%	100%		230 V	400 V	690 V	230 V	400 V	690 V
ENR 50-250/1,5	1,5	2	IE2	81,0	83,5	83,0	1,81	5,89	3,4	2,0	46,5	26,9	15,5
ENR 50-250/2,2	2,2	3	IE2	84,0	85,3	85,1	2,61	8,83	5,1	2,9	53,0	30,6	17,7
ENR 50-250/3	3	4	IE2	82,6	84,7	86,4	3,47	11,26	6,5	3,8	95,7	55,3	31,9
ENR 50-250/4	4,0	5,5	IE2	82,6	84,7	86,4	4,59	14,72	8,5	4,9	89,8	51,9	29,9
ENR 50-250/5,5	5,5	7,5	IE2	87,5	88,3	88,1	6,16	19,75	11,4	6,6	146,1	84,4	48,7
ENR 50-315/3	3	4	IE2	82,6	84,7	86,4	3,47	11,26	6,5	3,8	95,7	55,3	31,9
ENR 50-315/4	4	5,5	IE2	82,6	84,7	86,4	4,59	14,72	8,5	4,9	89,8	51,9	29,9
ENR 50-315/5,5	5,5	7,5	IE2	86,0	87,3	87,1	6,16	19,75	11,4	6,6	146,1	84,4	48,7
ENR 50-315/7,5	7,5	10	IE2	88,5	89,4	89,2	8,41	28,41	16,4	9,5	210,2	121,4	70,1
ENR 65-125/0,55	0,55	0,75	IE1	67,0	69,0	70,0	0,80	2,8	1,6	-	11,6	6,7	-
ENR 65-125/0,75	0,75	1	IE2	79,2	80,3	80,2	0,95	3,12	1,8	1,0	17,1	9,9	5,7
ENR 65-125/1,1	1,1	1,5	IE2	81,4	82,7	82,5	1,33	4,33	2,5	1,4	26,4	15,3	8,8
ENR 65-160/0,75	0,75	1	IE2	79,2	80,3	80,2	0,95	3,12	1,8	1,0	17,1	9,9	5,7
ENR 65-160/1,1	1,1	1,5	IE2	81,4	82,7	82,5	1,33	4,33	2,5	1,4	26,4	15,3	8,8
ENR 65-160/1,5	1,5	2	IE2	81,0	83,5	83,0	1,81	5,89	3,4	2,0	46,5	26,9	15,5
ENR 65-160/2,2	2,2	3	IE2	84,0	85,3	85,1	2,61	8,83	5,1	2,9	53,0	30,6	17,7
ENR 65-200/1,1	1,1	1,5	IE2	81,4	82,7	82,5	1,33	4,33	2,5	1,4	26,4	15,3	8,8
ENR 65-200/1,5	1,5	2	IE2	81,0	83,5	83,0	1,81	5,89	3,4	2,0	46,5	26,9	15,5
ENR 65-200/2,2	2,2	3	IE2	84,0	85,3	85,1	2,61	8,83	5,1	2,9	53,0	30,6	17,7
ENR 65-200/3	3	4	IE2	82,6	84,7	86,4	3,47	11,26	6,5	3,8	95,7	55,3	31,9
ENR 65-200/4	4	5,5	IE2	82,6	84,7	86,4	4,59	14,72	8,5	4,9	89,8	51,9	29,9
ENR 65-200/5,5	5,5	7,5	IE2	87,5	88,3	88,1	6,16	19,75	11,4	6,6	146,1	84,4	48,7
ENR 65-250/2,2	2,2	3	IE2	84,0	85,3	85,1	2,61	8,83	5,1	2,9	53,0	30,6	17,7
ENR 65-250/3	3	4	IE2	82,6	84,7	86,4	3,47	11,26	6,5	3,8	95,7	55,3	31,9
ENR 65-250/4	4	5,5	IE2	82,6	84,7	86,4	4,59	14,72	8,5	4,9	89,8	51,9	29,9
ENR 65-250/5,5	5,5	7,5	IE2	87,5	88,3	88,1	6,16	19,75	11,4	6,6	146,1	84,4	48,7
ENR 65-250/7,5	7,5	10	IE2	88,5	89,4	89,2	8,41	28,41	16,4	9,5	210,2	121,4	70,1
ENR 65-315/5,5	5,5	7,5	IE2	87,5	88,3	88,1	6,16	19,75	11,4	6,6	146,1	84,4	48,7
ENR 65-315/7,5	7,5	10	IE2	88,5	89,4	89,2	8,41	28,41	16,4	9,5	210,2	121,4	70,1
ENR 65-315/11	11	15	IE2	89,4	90,3	90,1	12,50	38,11	22,0	12,7	301,0	173,8	100,3
ENR 65-315/15	15	20	IE2	90,6	91,2	91,0	16,88	50,23	29,0	16,7	371,7	214,6	123,9
ENR 80-160/0,75	0,75	1	IE2	79,2	80,3	80,2	0,95	3,12	1,8	1,0	17,1	9,9	5,7
ENR 80-160/1,1	1,1	1,5	IE2	81,4	82,7	82,5	1,33	4,33	2,5	1,4	26,4	15,3	8,8
ENR 80-160/1,5	1,5	2	IE2	81,0	83,5	83,0	1,81	5,89	3,4	2,0	46,5	26,9	15,5
ENR 80-160/2,2	2,2	3	IE2	84,0	85,3	85,1	2,61	8,83	5,1	2,9	53,0	30,6	17,7
ENR 80-160/3	3	4	IE2	82,6	84,7	86,4	3,47	11,26	6,5	3,8	95,7	55,3	31,9
ENR 80-160/4	4	5,5	IE2	82,6	84,7	86,4	4,59	14,72	8,5	4,9	89,8	51,9	29,9
ENR 80-200/2,2	2,2	3	IE2	84,0	85,3	85,1	2,61	8,83	5,1	2,9	53,0	30,6	17,7
ENR 80-200/3	3	4	IE2	82,6	84,7	86,4	3,47	11,26	6,5	3,8	95,7	55,3	31,9
ENR 80-200/4	4	5,5	IE2	82,6	84,7	86,4	4,59	14,72	8,5	4,9	89,8	51,9	29,9
ENR 80-200/5,5	5,5	7,5	IE2	87,5	88,3	88,1	6,16	19,75	11,4	6,6	146,1	84,4	48,7
ENR 80-250/3	3	4	IE2	82,6	84,7	86,4	3,47	11,26	6,5	3,8	95,7	55,3	31,9
ENR 80-250/4	4	5,5	IE2	82,6	84,7	86,4	4,59	14,72	8,5	4,9	89,8	51,9	29,9
ENR 80-250/5,5	5,5	7,5	IE2	87,5	88,3	88,1	6,16	19,75	11,4	6,6	146,1	84,4	48,7
ENR 80-250/7,5	7,5	10	IE2	88,5	89,4	89,2	8,41	28,41	16,4	9,5	210,2	121,4	70,1
ENR 80-250/11	11	15	IE2	89,4	90,3	90,1	12,50	38,11	22,0	12,7	301,0	173,8	100,3

TECHNICAL DATA

50Hz

Rev. 0

MOTOR DATA 80 - 100 - 125 Version

Pump type Three Phase	Power		Efficiency Three Phase	Efficiency (% Three phase η %)			Input [kW]	Full load current [A]			Locked rotor current [A]		
	[kW]	[HP]		50%	75%	100%		230 V	400 V	690 V	230 V	400 V	690 V
ENR 80-315/5,5	5,5	7,5	IE2	87,5	88,3	88,1	6,16	19,75	11,4	6,6	146,1	84,4	48,7
ENR 80-315/7,5	7,5	10	IE2	88,5	89,4	89,2	8,41	28,41	16,4	9,5	210,2	121,4	70,1
ENR 80-315/11	11	15	IE2	89,4	90,3	90,1	12,50	38,11	22,0	12,7	301,0	173,8	100,3
ENR 80-315/15	15	20	IE2	90,6	91,2	91,0	16,88	50,23	29,0	16,7	371,7	214,6	123,9
ENR 80-315/18,5	18,5	22	IE2	90,9	91,6	91,4	20,26	-	34,4	19,9	-	268,3	154,9
ENR 80-315/22	22	30	IE2	91,1	92,0	91,6	24,04	-	41,3	23,8	-	309,8	178,8
ENR 80-315/30	30	40	IE2	90,2	92,8	92,5	32,44	-	53,2	30,7	-	420,3	242,6
ENR 80-400/11	11	15	IE2	89,4	90,3	90,1	12,50	38,11	22,0	12,7	301,0	173,8	100,3
ENR 80-400/15	15	20	IE2	90,6	91,2	91,0	16,88	50,23	29,0	16,7	371,7	214,6	123,9
ENR 80-400/18,5	18,5	22	IE2	90,9	91,6	91,4	20,26	-	34,4	19,9	-	268,3	154,9
ENR 80-400/22	22	30	IE2	91,1	92,0	91,6	24,04	-	41,3	23,8	-	309,8	178,8
ENR 80-400/30	30	40	IE2	90,2	92,8	92,5	32,44	-	53,2	30,7	-	420,3	242,6
ENR 100-160/2,2	2,2	3	IE2	84,0	85,3	85,1	2,61	8,83	5,1	2,9	53,0	30,6	17,7
ENR 100-160/3	3	4	IE2	82,6	84,7	86,4	3,47	11,26	6,5	3,8	95,7	55,3	31,9
ENR 100-160/4	4	5,5	IE2	82,6	84,7	86,4	4,59	14,72	8,5	4,9	89,8	51,9	29,9
ENR 100-160/5,5	5,5	7,5	IE2	87,5	88,3	88,1	6,16	19,75	11,4	6,6	146,1	84,4	48,7
ENR 100-200/2,2	2,2	3	IE2	84,0	85,3	85,1	2,61	8,83	5,1	2,9	53,0	30,6	17,7
ENR 100-200/3	3	4	IE2	82,6	84,7	86,4	3,47	11,26	6,5	3,8	95,7	55,3	31,9
ENR 100-200/4	4	5,5	IE2	82,6	84,7	86,4	4,59	14,72	8,5	4,9	89,8	51,9	29,9
ENR 100-200/5,5	5,5	7,5	IE2	87,5	88,3	88,1	6,16	19,75	11,4	6,6	146,1	84,4	48,7
ENR 100-200/7,5	7,5	10	IE2	88,5	89,4	89,2	8,41	28,41	16,4	9,5	210,2	121,4	70,1
ENR 100-250/4	4	5,5	IE2	82,6	84,7	86,4	4,59	14,72	8,5	4,9	89,8	51,9	29,9
ENR 100-250/5,5	5,5	7,5	IE2	87,5	88,3	88,1	6,16	19,75	11,4	6,6	146,1	84,4	48,7
ENR 100-250/7,5	7,5	10	IE2	88,5	89,4	89,2	8,41	28,41	16,4	9,5	210,2	121,4	70,1
ENR 100-250/11	11	15	IE2	89,4	90,3	90,1	12,50	38,11	22,0	12,7	301,0	173,8	100,3
ENR 100-250/15	15	20	IE2	90,6	91,2	91,0	16,88	50,23	29,0	16,7	371,7	214,6	123,9
ENR 100-315/11	11	15	IE2	89,4	90,3	90,1	12,50	38,11	22,0	12,7	301,0	173,8	100,3
ENR 100-315/15	15	20	IE2	90,6	91,2	91,0	16,88	50,23	29,0	16,7	371,7	214,6	123,9
ENR 100-315/18,5	18,5	22	IE2	90,9	91,6	91,4	20,26	-	34,4	19,9	-	268,3	154,9
ENR 100-315/22	22	30	IE2	91,1	92,0	91,6	24,04	-	41,3	23,8	-	309,8	178,8
ENR 100-315/30	30	40	IE2	90,2	92,8	92,5	32,44	-	53,2	30,7	-	420,3	242,6
ENR 100-400/15	15	20	IE2	90,6	91,2	91,0	16,88	50,23	29,0	16,7	371,7	214,6	123,9
ENR 100-400/18,5	18,5	22	IE2	90,9	91,6	91,4	20,26	-	34,4	19,9	-	268,3	154,9
ENR 100-400/22	22	30	IE2	91,1	92,0	91,6	24,04	-	41,3	23,8	-	309,8	178,8
ENR 100-400/30	30	40	IE2	90,2	92,8	92,5	32,44	-	53,2	30,7	-	420,3	242,6
ENR 100-400/37	37	50	IE2	92,3	92,9	92,8	39,85	-	69,3	40,0	-	464,3	268,1
ENR 100-400/45	45	60	IE2	92,5	93,2	93,3	48,25	-	83,9	48,4	-	587,3	339,1
ENR 125-200/7,5	7,5	10	IE2	88,5	89,4	89,2	8,41	28,41	16,4	9,5	210,2	121,4	70,1
ENR 125-200/11	11	15	IE2	89,4	90,3	90,1	12,50	38,11	22,0	12,7	301,0	173,8	100,3
ENR 125-200/15	15	20	IE2	90,6	91,2	91,0	16,88	50,23	29,0	16,7	371,7	214,6	123,9
ENR 125-250/7,5	7,5	10	IE2	87,5	88,3	88,1	8,41	28,41	16,4	9,5	210,2	121,4	70,1
ENR 125-250/11	11	15	IE2	89,4	90,3	90,1	12,50	38,11	22,0	12,7	301,0	173,8	100,3
ENR 125-250/15	15	20	IE2	90,6	91,2	91,0	16,88	50,23	29,0	16,7	371,7	214,6	123,9
ENR 125-250/18,5	18,5	22	IE2	90,9	91,6	91,4	20,26	-	34,4	19,9	-	268,3	154,9
ENR 125-250/22	22	30	IE2	91,1	92,0	91,6	24,04	-	41,3	23,8	-	309,8	178,8

TECHNICAL DATA

50Hz

Rev. 0

MOTOR DATA 125 - 150 - 200 Version

Pump type Three Phase	Power		Efficiency Three Phase	Efficiency (% Three phase η %)			Input [kW]	Full load current [A]			Locked rotor current [A]		
	[kW]	[HP]		50%	75%	100%		230 V	400 V	690 V	230 V	400 V	690 V
ENR 125-315/15	15	20	IE2	90,6	91,2	91,0	16,88	50,23	29,0	16,7	371,7	214,6	123,9
ENR 125-315/18,5	18,5	22	IE2	90,9	91,6	91,4	20,26	-	34,4	19,9	-	268,3	154,9
ENR 125-315/22	22	30	IE2	91,1	92,0	91,6	24,04	-	41,3	23,8	-	309,8	178,8
ENR 125-315/30	30	40	IE2	90,2	92,8	92,5	32,44	-	53,2	30,7	-	420,3	242,6
ENR 125-315/37	37	50	IE2	92,3	92,9	92,8	39,85	-	69,3	40,0	-	464,3	268,1
ENR 125-400/30	30	40	IE2	90,2	92,8	92,5	32,44	-	53,2	30,7	-	420,3	242,6
ENR 125-400/37	37	50	IE2	92,3	92,9	92,8	39,85	-	69,3	40,0	-	464,3	268,1
ENR 125-400/45	45	60	IE2	92,5	93,2	93,3	48,25	-	83,9	48,4	-	587,3	339,1
ENR 125-400/55	55	75	IE2	93,1	94,0	93,8	58,65	-	97,3	56,2	-	720,0	415,7
ENR 125-400/75	75	100	IE2	93,2	94,5	94,4	79,44	-	127,4	73,6	-	955,5	551,7
ENR 150-200/7,5	7,5	10	IE2	88,5	89,4	89,2	8,41	28,41	16,4	9,5	210,2	121,4	70,1
ENR 150-200/11	11	15	IE2	89,4	90,3	90,1	12,50	38,11	22,0	12,7	301,0	173,8	100,3
ENR 150-200/15	15	20	IE2	90,6	91,2	91,0	16,88	50,23	29,0	16,7	371,7	214,6	123,9
ENR 150-200/18,5	18,5	22	IE2	90,9	91,6	91,4	20,26	-	34,4	19,9	-	268,3	154,9
ENR 150-250/15	15	20	IE2	90,6	91,2	91,0	16,88	50,23	29,0	16,7	371,7	214,6	123,9
ENR 150-250/18,5	18,5	22	IE2	90,9	91,6	91,4	20,26	-	34,4	19,9	-	268,3	154,9
ENR 150-250/22	22	30	IE2	91,1	92,0	91,6	24,04	-	41,3	23,8	-	309,8	178,8
ENR 150-250/30	30	40	IE2	90,2	92,8	92,5	32,44	-	53,2	30,7	-	420,3	242,6
ENR 150-250/37	37	50	IE2	92,3	92,9	92,8	39,85	-	69,3	40,0	-	464,3	268,1
ENR 150-315/18,5	18,5	22	IE2	90,9	91,6	91,4	20,26	-	34,4	19,9	-	268,3	154,9
ENR 150-315/22	22	30	IE2	91,1	92,0	91,6	24,04	-	41,3	23,8	-	309,8	178,8
ENR 150-315/30	30	40	IE2	90,2	92,8	92,5	32,44	-	53,2	30,7	-	420,3	242,6
ENR 150-315/37	37	50	IE2	92,3	92,9	92,8	39,85	-	69,3	40,0	-	464,3	268,1
ENR 150-315/45	45	60	IE2	92,5	93,2	93,3	48,25	-	83,9	48,4	-	587,3	339,1
ENR 150-315/55	55	75	IE2	93,1	94,0	93,8	58,65	-	97,3	56,2	-	720,0	415,7
ENR 150-400/45	45	60	IE2	92,5	93,2	93,3	48,25	-	83,9	48,4	-	587,3	339,1
ENR 150-400/55	55	75	IE2	93,1	94,0	93,8	58,65	-	97,3	56,2	-	720,0	415,7
ENR 150-400/75	75	100	IE2	93,2	94,5	94,4	79,44	-	127,4	73,6	-	955,5	551,7
ENR 150-400/90	90	120	IE2	93,4	94,8	94,7	95,03	-	152,4	88,0	-	1173,5	677,5
ENR 200-250/15	15	20	IE2	90,6	91,2	91,0	16,88	50,23	29,0	16,7	371,7	214,6	123,9
ENR 200-250/18,5	18,5	22	IE2	90,9	91,6	91,4	20,26	-	34,4	19,9	-	268,3	154,9
ENR 200-250/22	22	30	IE2	91,1	92,0	91,6	24,04	-	41,3	23,8	-	309,8	178,8
ENR 200-250/30	30	40	IE2	90,2	92,8	92,5	32,44	-	53,2	30,7	-	420,3	242,6

NOISE DATA

Power		L _{pA} - dB(A) *
[kW]	[HP]	
0,37	0,55	<70
0,55	0,75	
0,75	1	
1,1	1,5	
1,5	2	
2,2	3	72
3	4	78
4	5,5	
5,5	7,5	80
7,5	10	
11	15	
15	20	81
18,5	25	
22	30	83
30	40	
37	50	85
45	60	
55	75	86
75	100	88
90	125	90

* Mean value of several measures at 1m distance around the pump. Tolerance ± 2.5 dB.