

APPLICAZIONI

Elettropompe sommerse per drenaggio in cantieri, fossi, canali e sottopassaggi. Impegate per pompare acqua fuori dalle cantine, garages e scantinati.

Particolarmente adatte per il prosciugamento di acqua sporca contenente una moderata quantità di materiale abrasivo.

LIMITI D'IMPIEGO

- Temperatura liquido fino a 35°C
(per un uso domestico secondo EN 60335-2-41)
Temperatura max. liquido: 50°C (per altri impieghi)
- Massima profondità d'immersione 20 mt.
(con cavo di lunghezza adatta)
- Passaggio solidi Ø 7,5 mm (ASM 315)
- Passaggio solidi Ø 10,5 mm
- Livello min. d'aspirazione 85 mm (ASM 315)
- Livello min. d'aspirazione 120 mm

MOTORE

- Monofase 230V-50Hz
- Trifase 230/400V-50Hz
- Condensatore permanente inserito (ASM 315 µF10 ; ASM 520 µF15)
- Isolamento Classe F
- Protezione IP 68

MATERIALI

- Corpo motore Acciaio Inox AISI 304
- Cilindro motore Acciaio Inox AISI 304
- Coperchio motore Acciaio Inox AISI 304
- Corpo pompa Ghisa
- Girante Lega Cromo (HCR)
- Albero motore Acciaio Inox AISI 304
- Doppia tenuta meccanica in camera d'olio Ceramica/Grafite/NBR
Silicio/Silicio/NBR

OPERATING CONDITIONS

- Liquid temperature up to 35°C
(for home use according to EN 60335-2-41)
Temperature max. liquid: 50°C (for other uses)
- Maximum immersion depth 20 mt.
(with a cable of the appropriate length)
- Grain size inlet Ø 7,5 mm (ASM 315)
- Grain size inlet Ø 10,5 mm
- Min. suction level 85 mm (ASM 315)
- Min. suction level 120 mm

MOTOR

- Single-phase 230V-50Hz
- Three-phase 230/400V-50Hz
- Permanent split capacitor (ASM 315 µF10 ; ASM 520 µF15)
- Insulation Class F
- Protection IP 68

MATERIALS

- Out cover Stainless steel AISI 304
- Motor frame Stainless steel AISI 304
- Upper cover Stainless steel AISI 304
- Pump body Spheroidal cast iron
- Impeller High chrome alloy (HCR)
- Shaft Stainless steel AISI 304
- Double mechanical seal in oil chamber Ceramic/Graphite/NBR
Silicon/Silicon/NBR

APPLICATION

For the drainage of construction sites, trench ducts, and underground passages.

Suitable to pump water out from cellars, garages and basements. Disposal of moderately heavy water containing some abrasive material.

ASM 520



GIRANTE - IMPELLER

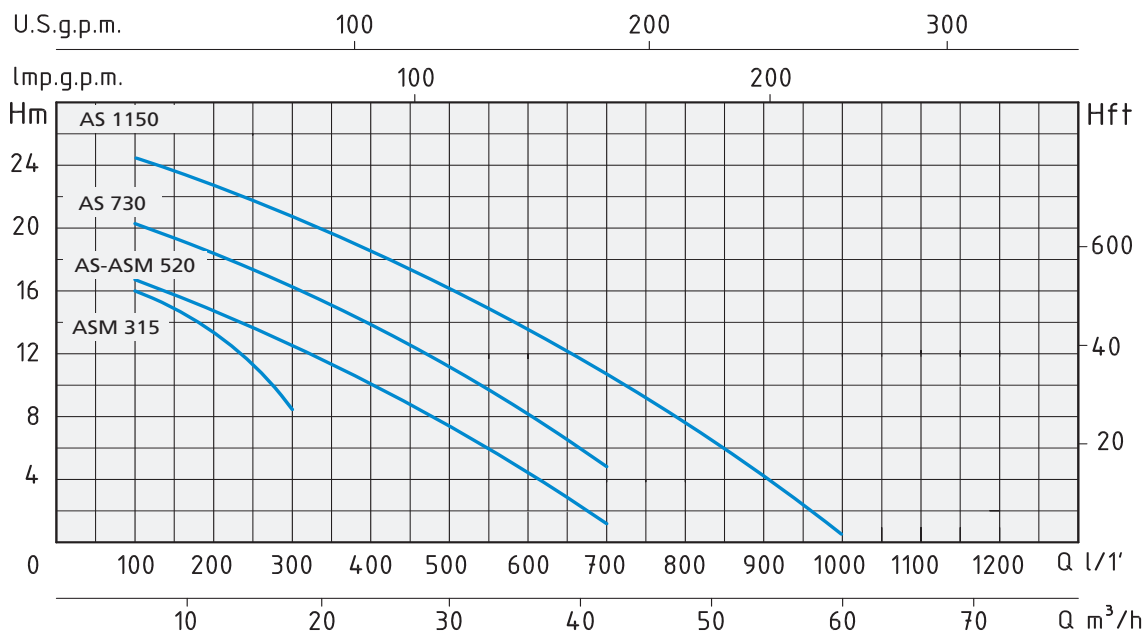

TIPO TYPE		POTENZA NOMINALE NOMINAL POWER		POTENZA ASSORBITA INPUT POWER	AMPERE		Q = PORTATA - CAPACITY							
Monofase Single-phase	Trifase Three-phase	P2		P1	Monofase Single-phase	Trifase Three-phase	m³/h	6	12	18	30	42	48	60
		HP	kW	kW			lt/1'	100	200	300	500	700	800	1000
Prevalenza manometrica totale in m.C.A. - Total head in meters w.c.														
ASM 315		1,5	1,1	1,7	8,2		H	16	13,5	8,3				
ASM 520	AS 520	2	1,5	1,9	10	3,5		16,5	14,4	12,3	7,2	1,6		
	AS 730	3	2,2	3		5		20,5	18,6	16,4	11,4	4,6		
	AS 1150	5	4	5		8,2		24,5	23	21	16	11	7	1

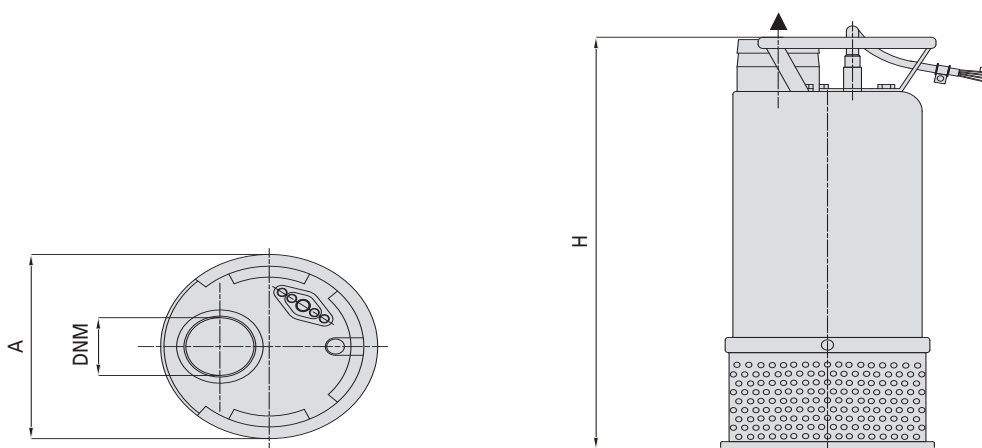

TIPO TYPE		DIMENSIONI mm - DIMENSIONS mm				DIMENSIONI DIMENSIONS mm			PESO WEIGHT
Monofase Single-phase	Trifase Three-phase	A	H	DNM	CAVO CABLE	P	L	H	Kg
ASM 315		210	482	2"	10 mt H07RNF	261	228	535	30,9
ASM 520	AS 520	238	601 - 521	3"	10 mt H07RNF	287	359	585	42,1
	AS 730	238	521	3"	10 mt H07RNF	287	359	585	45,2
	AS 1150	238	661	3"	10 mt H07RNF	267	279	680	49,5