

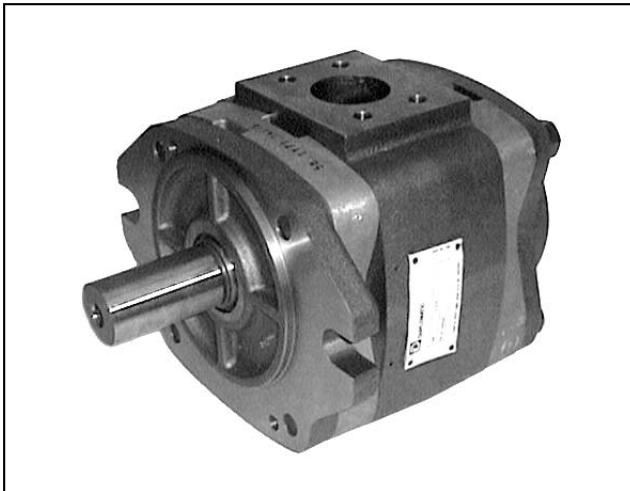

**DIPLOMATIC
HYDRAULICS**

12 100/298 ED



IGP

INTERNAL GEAR PUMPS

SERIES 10

OPERATING PRINCIPLE

- IGP pumps are volumetric displacement pumps with internal gears, available in five sizes, each divided into a range of different displacement.
- The pumps feature high volumetric performance levels, thanks to both radial and axial compensation in proportion to operating pressure, in addition to low noise levels.
- Optimal load distribution and special friction bearings enable continuous duty at high pressures and ensure extended pump lifetime.
- IGP pumps are also available in multiple versions which can be combined to make multi-flow groups.

TECHNICAL SPECIFICATIONS

IGP PUMP SIZE		3	4	5	6	7
Displacement range	cm ³ /rev	3,6 ÷ 10,2	13,3 ÷ 32,6	33,1 ÷ 64,9	64,1 ÷ 126,2	125,8 ÷ 251,7
Flow rate range (at 1.500 rpm)	l/min.	5,4 ÷ 15,3	19,9 ÷ 48,9	49,6 ÷ 97,3	96,1 ÷ 189,3	188,7 ÷ 377,5
Operating pressures		see table 3 - performances				
Rotation speed		see table 3 - performances				
Rotation direction		clockwise or anticlockwise (seen from the shaft side)				
Loads on the shaft		consult our technical department for the extent of axial and radial loads				
Hydraulic connection		flanged fittings SAE J518 c code 61 (see par. 28)				
Type of fastening		flanged SAE J744 c				
Mass (single pump)	kg	4 ÷ 4,8	8,6 ÷ 11	15,5 ÷ 18,7	29,2 ÷ 35	46,5 ÷ 59

Ambient temperature range	°C	-10 / +60
Fluid temperature range	°C	-10 / +80
Fluid viscosity range	see par. 2.2	
Recommended true viscosity	cSt	25 ÷ 100
Degree of fluid contamination	see par. 2.3	

HYDRAULIC SYMBOL

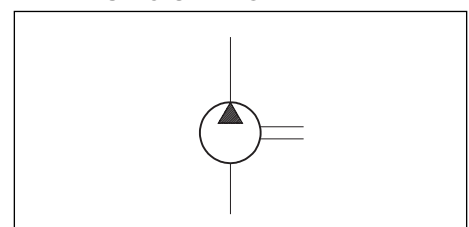



1 - IDENTIFICATION CODE

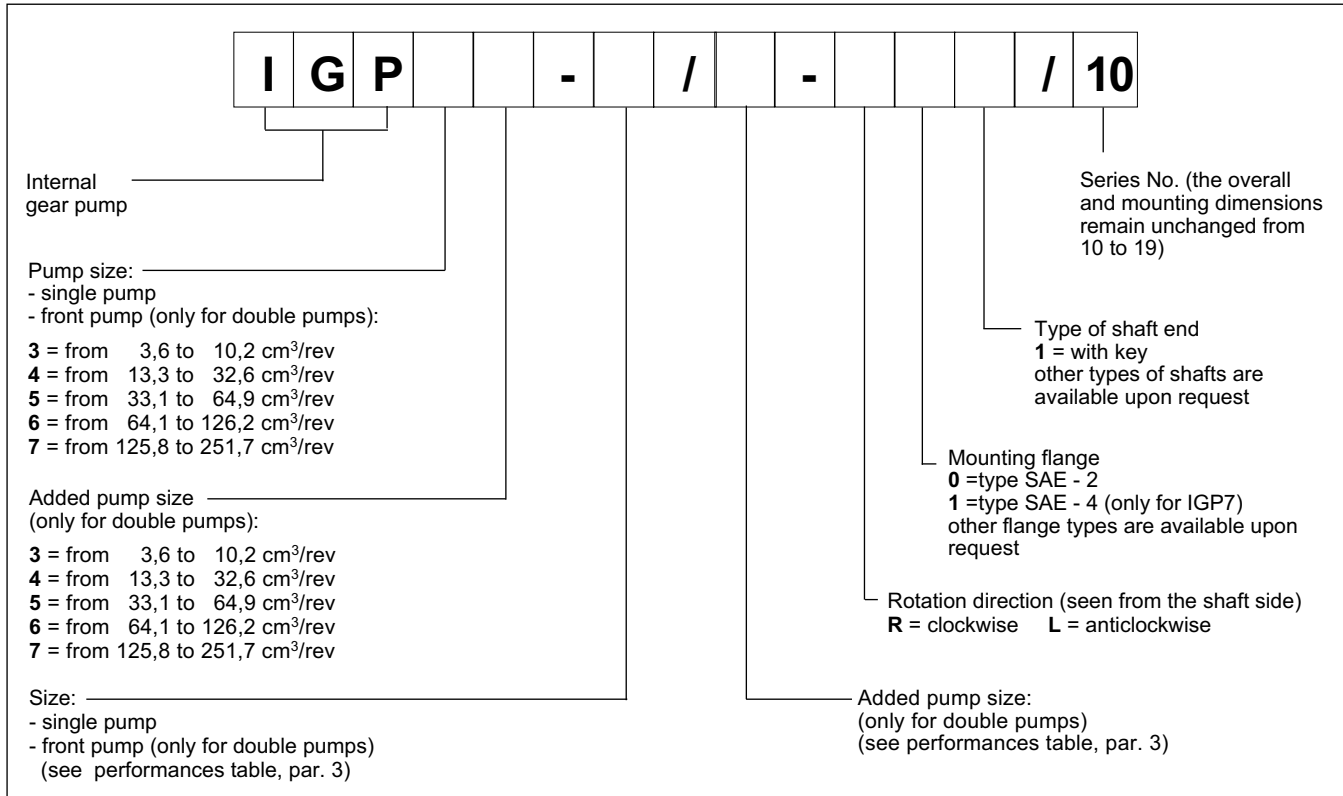

2 - HYDRAULIC FLUID

2.1 - Fluid type

Use mineral oil based hydraulic fluids with anti-foam and antioxidant additives.

For use with other types of fluid, keep in mind the limitations shown in the following table or consult our technical department for authorization of use.

FLUID TYPE	NOTES
HFC (water glycol solution with proportion of water ≤ 40 %)	<ul style="list-style-type: none"> - The performances shown in the table in par. 3 must be reduced of 20%. - The maximum speed of the fluid in the suction line must not exceed 1 m/s. - The suction pressure must not be less than 0,8 bar absolute. - The maximum fluid temperature must be less than 50°C.
HFD (phosphate esters)	Operation with this type of fluid is not allowed.

2.2 - Fluid viscosity

The operating fluid viscosity must be within the following range:

minimum viscosity	10 cSt	referred to the maximum fluid temperature of 80 °C
optimum viscosity	25 + 100 cSt	referred to the fluid working temperature in the tank
maximum viscosity	2000 cSt	limited to only the start-up phase of the pump

When selecting the fluid type, be sure that the true viscosity is within the range specified above at the operating temperature.

2.3 - Degree of fluid contamination

The maximum degree of fluid contamination must be according to ISO 4406:1999 class 20/18/15; therefore, use of a filter with $\beta_{20} \geq 75$ is recommended. A degree of maximum fluid contamination according to ISO 4406:1999 class 18/16/13 is recommended for optimum endurance of the pump. Hence, use of a filter with $\beta_{10} \geq 100$ is recommended.

If there is a filter installed on the suction line, be sure that the pressure at the pump inlet is not lower than the values specified in paragraph 3. The suction filter must be equipped with a by-pass valve and, if possible, with a clogging indicator.



3 - PERFORMANCES (obtained with mineral oil with viscosity in the range of 25 + 100 cSt)

PUMP SIZE	NOMINAL DIMENSION	DISPLACEMENT [cm ³ /rev] (note 2)	MAX. FLOW RATE (at 1500 rpm) [l/min.]	PRESSURE [bar] (note 3) steady/peak		MAX. ROTATION SPEED [rpm]	MIN. ROTATION SPEED [rpm] (note 4)
IGP3	003	3,6	5,4	330	345	3600	400
	005	5,2	7,8				
	006	6,4	9,6				
	008	8,2	12,3				
	010	10,2	15,3				
IGP4	013	13,3	19,9	330	345	3600	400
	016	15,8	23,7			3400	
	020	20,7	31,0			3200	
	025	25,4	38,1	300	330	3000	
	032	32,6	48,9	250	280	2800	
IGP5	032	33,1	49,6	315	345	3000	400
	040	41	61,5			2800	
	050	50,3	75,4	280	315	2500	
	064	64,9	97,3	230	250	2200	
IGP6	064	64,1	96,1	300	330	2600	400
	080	80,7	121,0	280	315	2400	
	100	101,3	151,9	250	300	2100	
	125	126,2	189,3	210	250	1800	
IGP7	125	125,8	188,7	300	330	2200	400
	160	160,8	241,2	280	315	2000	
	200	202,7	304,0	250	300	1800	
	250	251,7	377,5	210	250		

Note 1) In continuous operating conditions, the maximum suction pressure is 2 bar while the minimum pressure must not be less than -0,2 bar. A minimum suction pressure of - 0,4 bar is allowed for brief periods of time (the pressure values are to be considered relative).

Note 2) The working tolerances can reduce the displacement by 1,5% max. The flow rate at 1500 rpm shown in the table considers operation with pressure of 10 bar.

Note 3) The steady and peak pressures shown above are valid in the speed range of 400-1500 rpm. For speeds greater than 1500 rpm, the extent of the peak pressure must be reduced.

Note 4) For use at variable speed in the range less than 400 rpm or greater than 1500 rpm, there are limitations of the allowable pressures. Contact our technical department for applications outside this range.



4- IGP3 PUMP CHARACTERISTIC CURVES (values obtained with mineral oil with viscosity of 46 cSt at 40°C)

The data shown in the diagrams were noted with pump rotation speed = 1500 rpm.

FLOW RATE/PRESSURE CURVES

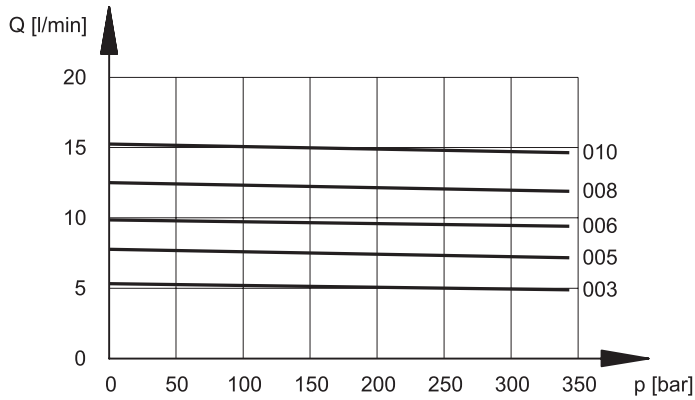

VOLUMETRIC AND TOTAL EFFICIENCY

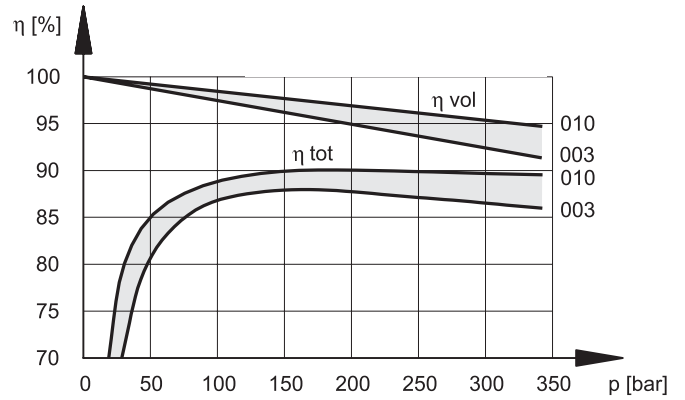

ABSORBED POWER

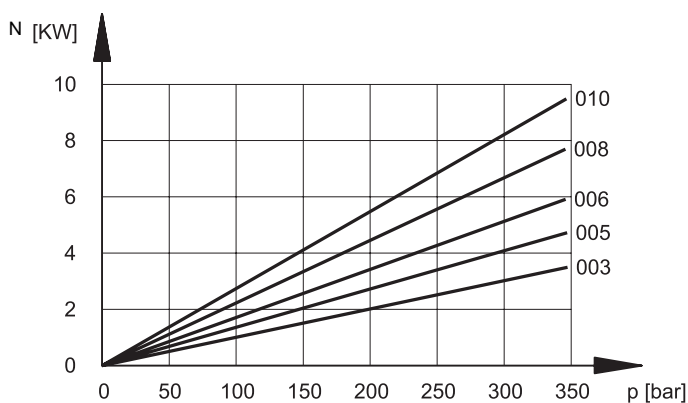

NOISE LEVEL

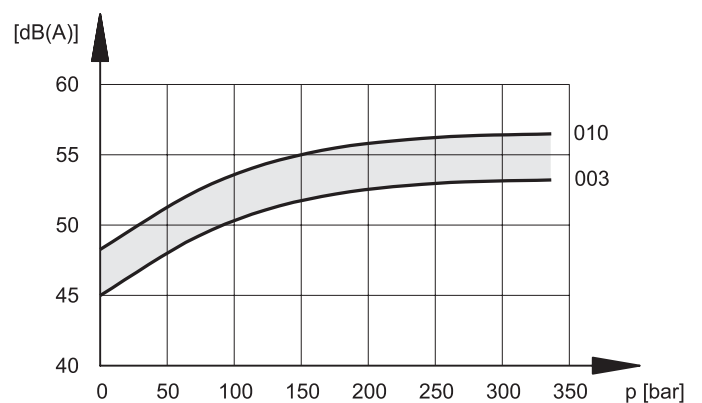

The noise pressure levels were measured in a semi-anechoic room, at an axial distance of 1 m from the pump.

The values shown must be reduced by 5 dB(A) if they are to be considered in a completely anechoic room.



5- IGP4 PUMP CHARACTERISTIC CURVES (obtained with mineral oil with viscosity of 46 cSt at 40°C)

The data shown in the diagrams were noted with pump rotation speed = 1500 rpm.

FLOW RATE/PRESSURE CURVES

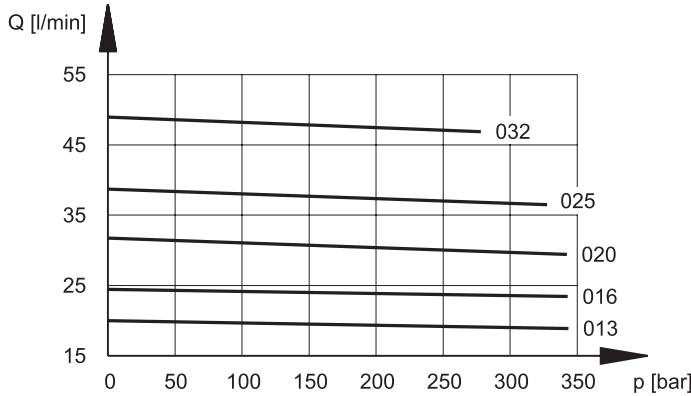

VOLUMETRIC AND TOTAL EFFICIENCY

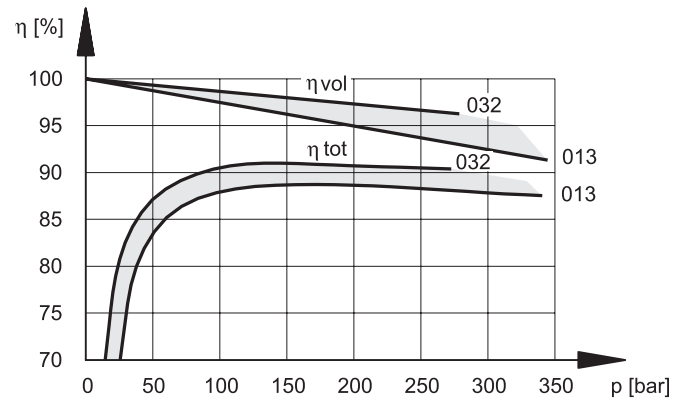

ABSORBED POWER

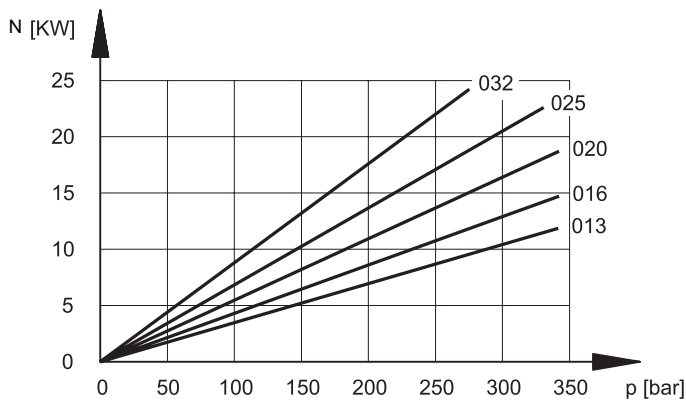

NOISE LEVEL

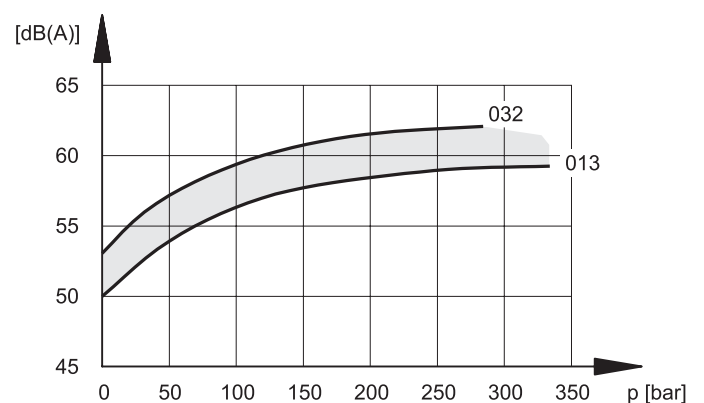

The noise pressure levels were measured in a semi-anechoic room, at an axial distance of 1 m from the pump.
The values shown must be reduced by 5 dB(A) if they are to be considered in a completely anechoic room.



6- IGP5 PUMP CHARACTERISTIC CURVES (values obtained with mineral oil with viscosity of 46 cSt at 40°C)

The data shown in the diagrams were noted with pump rotation speed = 1500 rpm.

FLOW RATE/PRESSURE CURVES

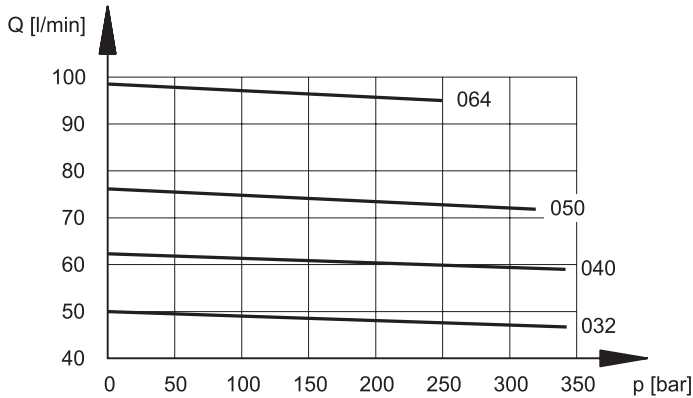

VOLUMETRIC AND TOTAL EFFICIENCY

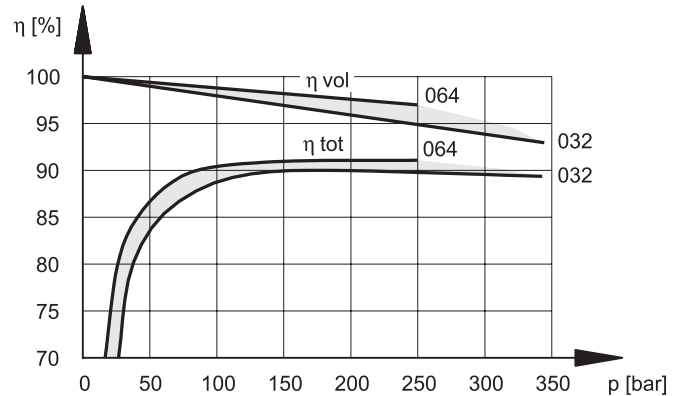

ABSORBED POWER

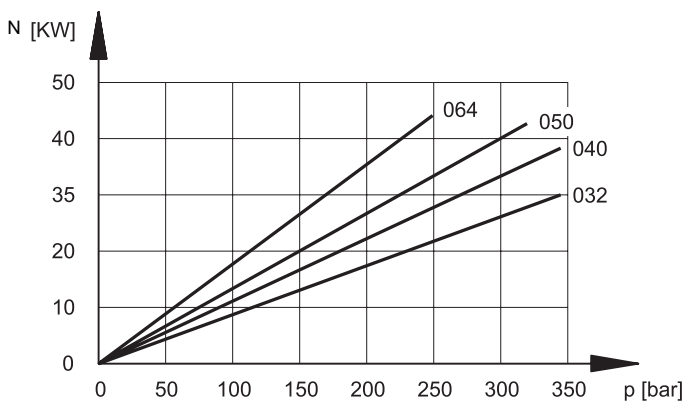

NOISE LEVEL

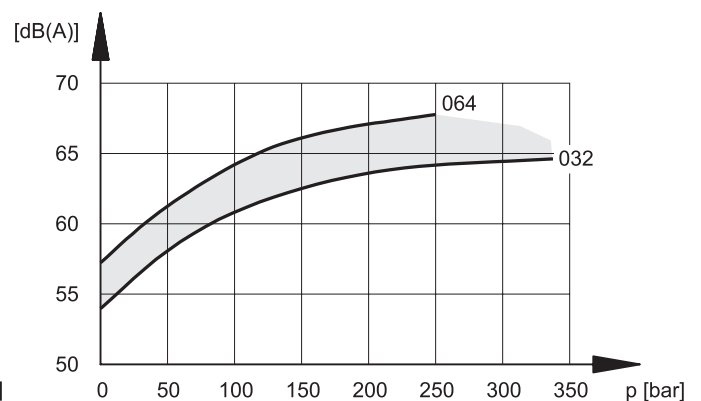

The noise pressure levels were measured in a semi-anechoic room, at an axial distance of 1 m from the pump.

The values shown must be reduced by 5 dB(A) if they are to be considered in a completely anechoic room.



7- IGP6 PUMP CHARACTERISTIC CURVES (obtained with mineral oil with viscosity of 46 cSt at 40°C)

The data shown in the diagrams were noted with pump rotation speed = 1500 rpm.

FLOW RATE/PRESSURE CURVES

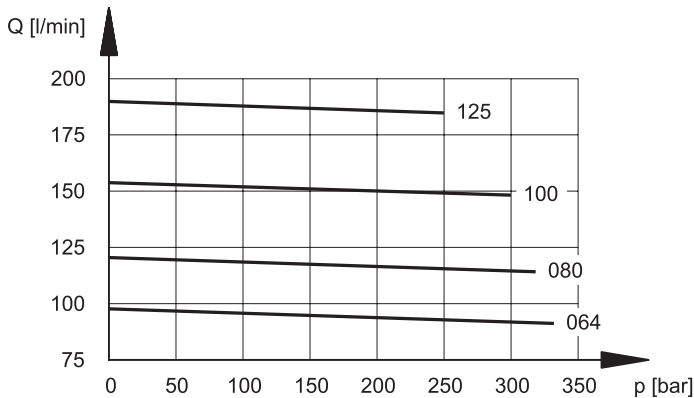

VOLUMETRIC AND TOTAL EFFICIENCIES

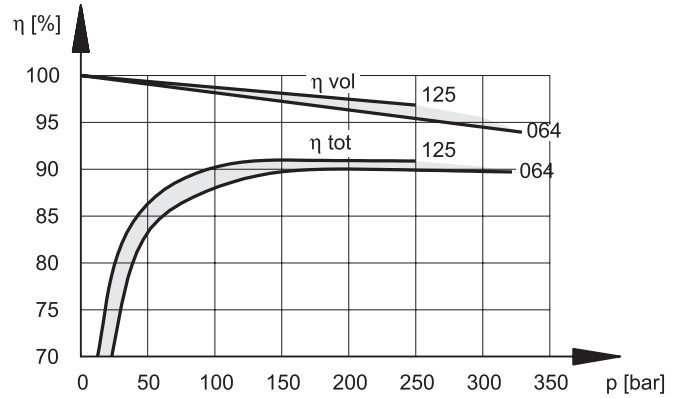

ABSORBED POWER

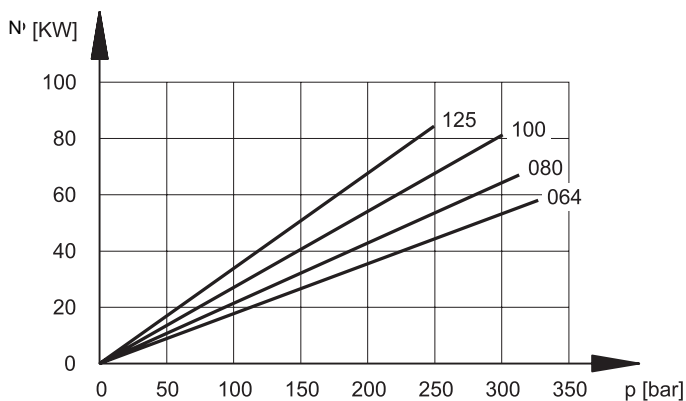

NOISE LEVEL

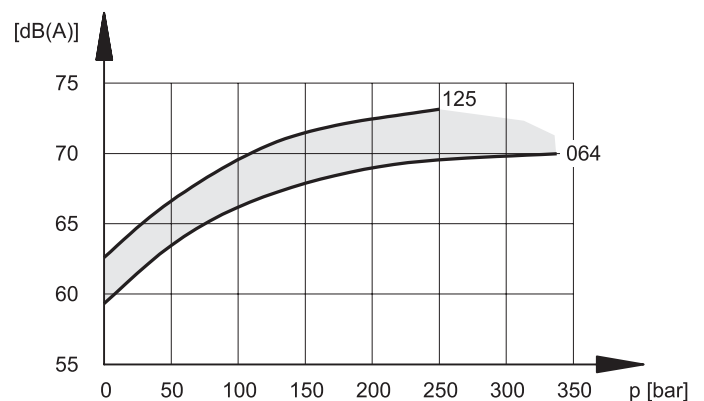

The noise pressure levels were measured in a semi-anechoic room, at an axial distance of 1 m from the pump.

The values shown must be reduced by 5 dB(A) if they are to be considered in a completely anechoic room.



8- IGP7 PUMP CHARACTERISTIC CURVES (values obtained with mineral oil with viscosity of 46 cSt at 40°C)

The data shown in the diagrams were noted with pump rotation speed = 1500 rpm.

FLOW RATE/PRESSURE CURVES

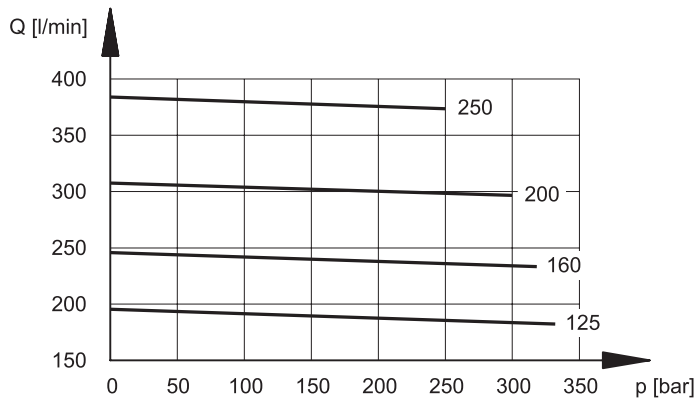

VOLUMETRIC AND TOTAL EFFICIENCY

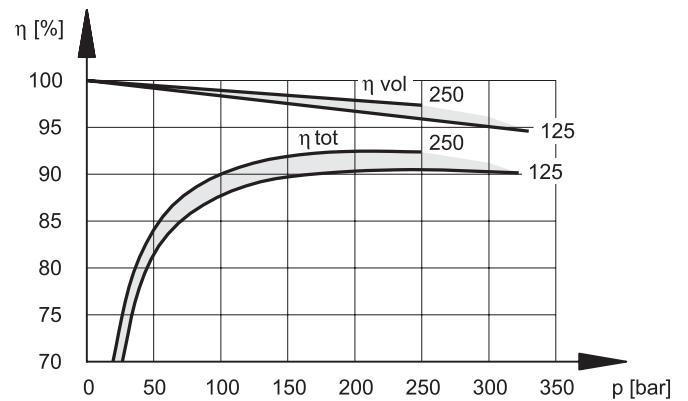

ABSORBED POWER

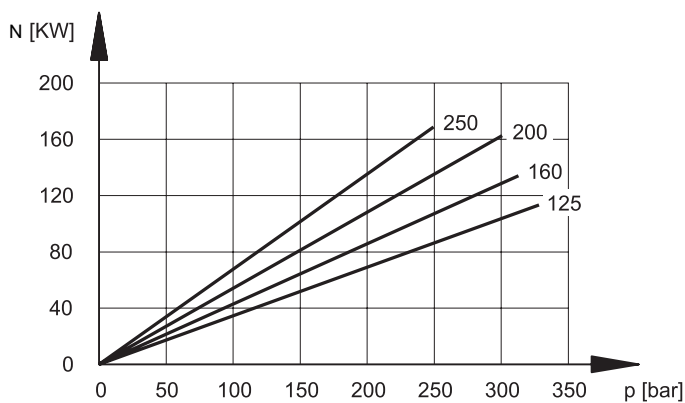

NOISE LEVEL

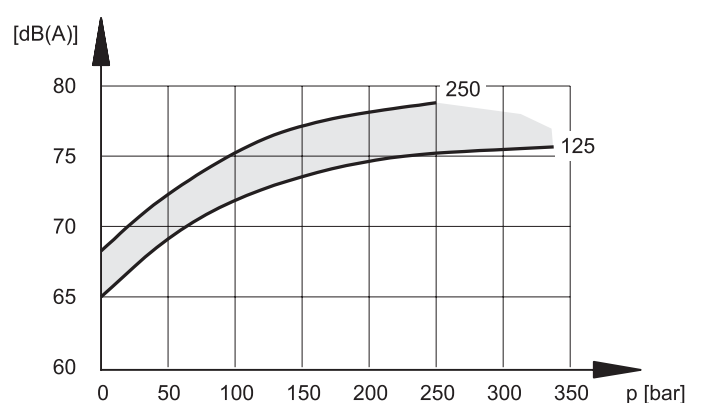

The noise pressure levels were measured in a semi-anechoic room, at an axial distance of 1 m from the pump.

The values shown must be reduced by 5 dB(A) if they are to be considered in a completely anechoic room.



9- IGP3 PUMP OVERALL AND MOUNTING DIMENSIONS

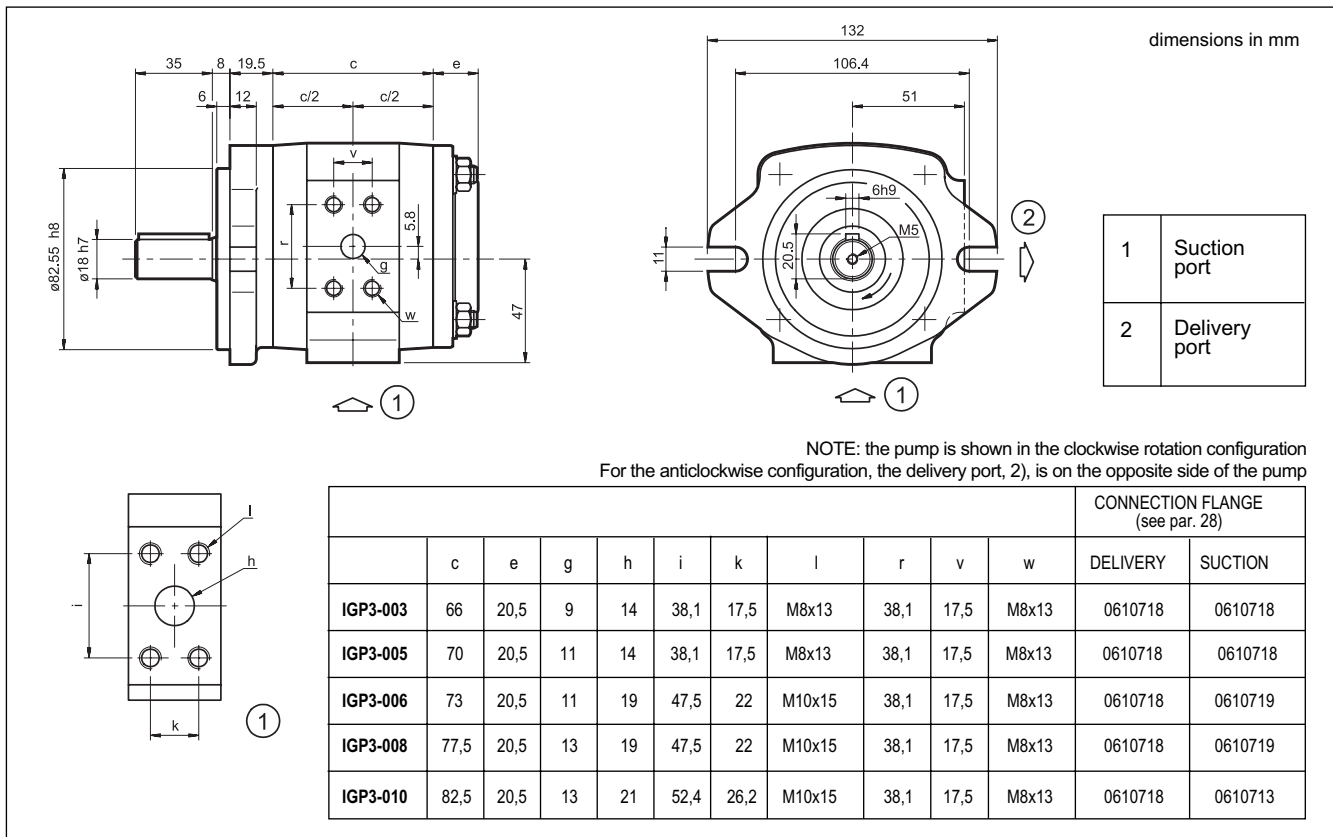

10- IGP4 PUMP OVERALL AND MOUNTING DIMENSIONS

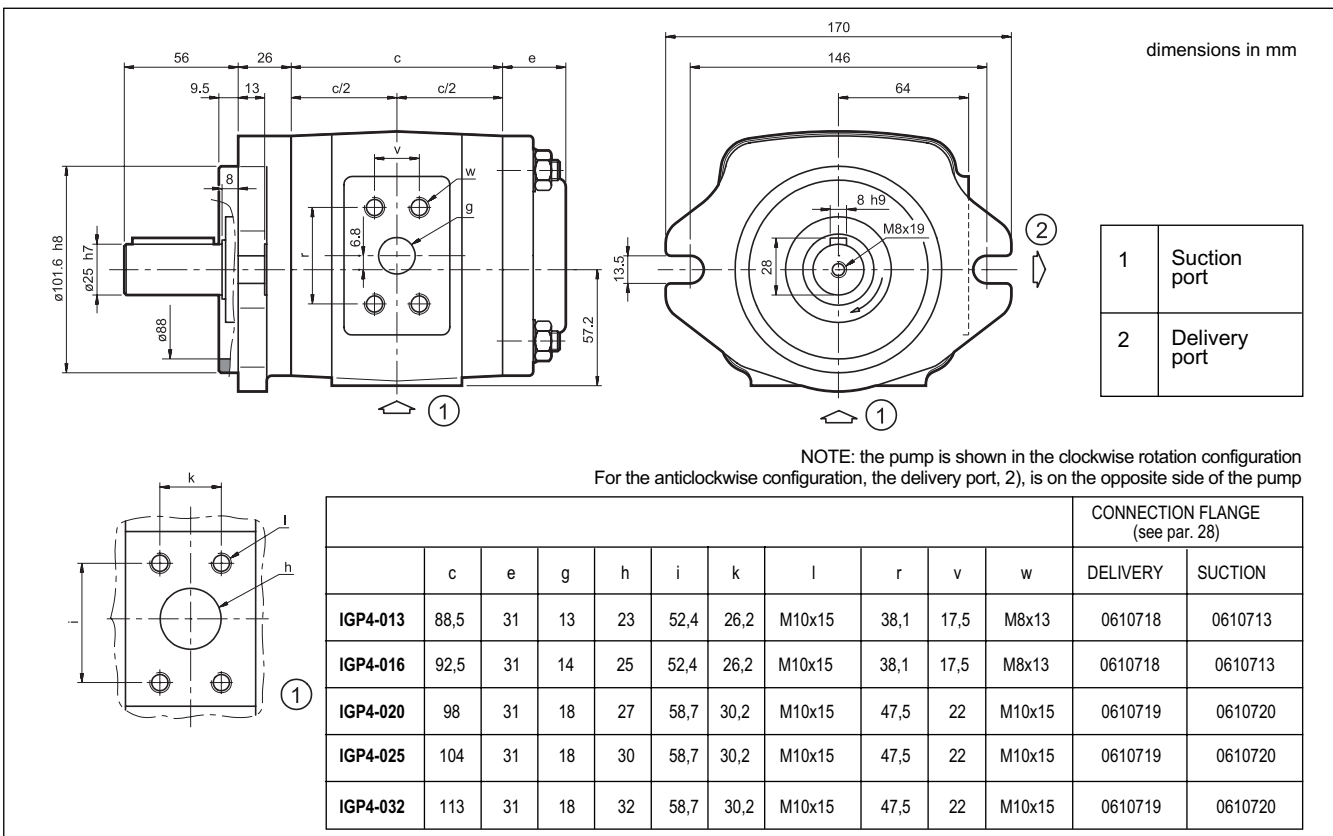



11- IGP5 PUMP OVERALL AND MOUNTING DIMENSIONS

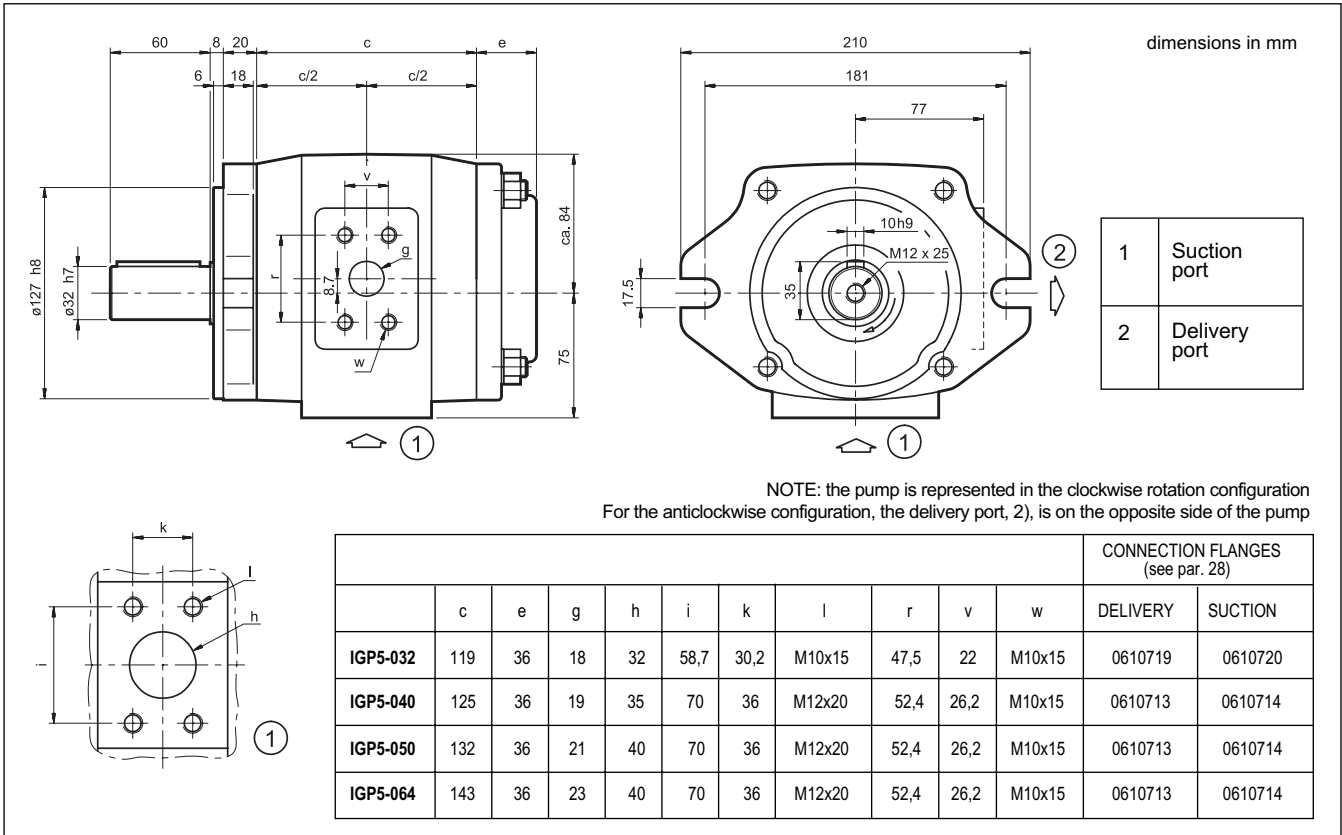

12- IGP6 PUMP OVERALL AND MOUNTING DIMENSIONS

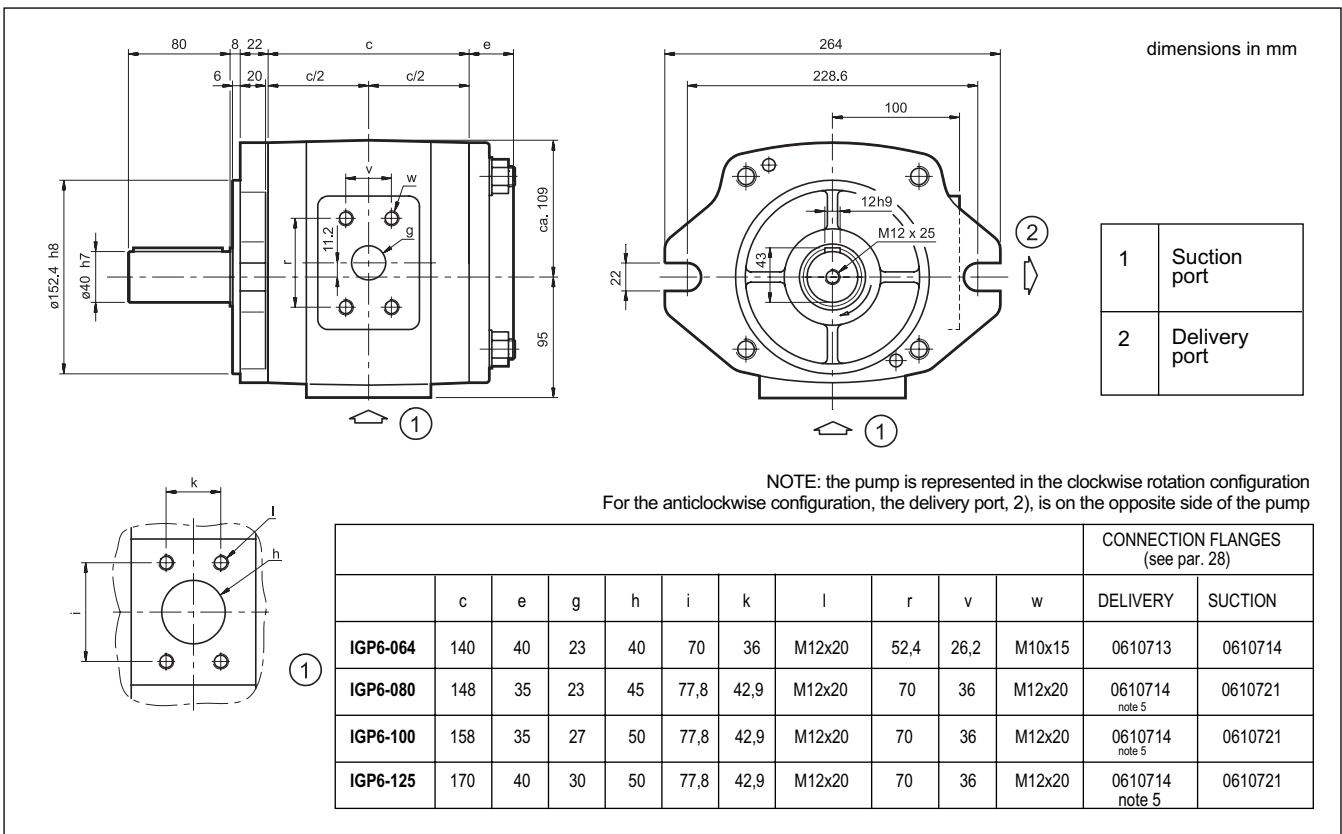



13- IGP7 PUMP OVERALL AND MOUNTING DIMENSIONS

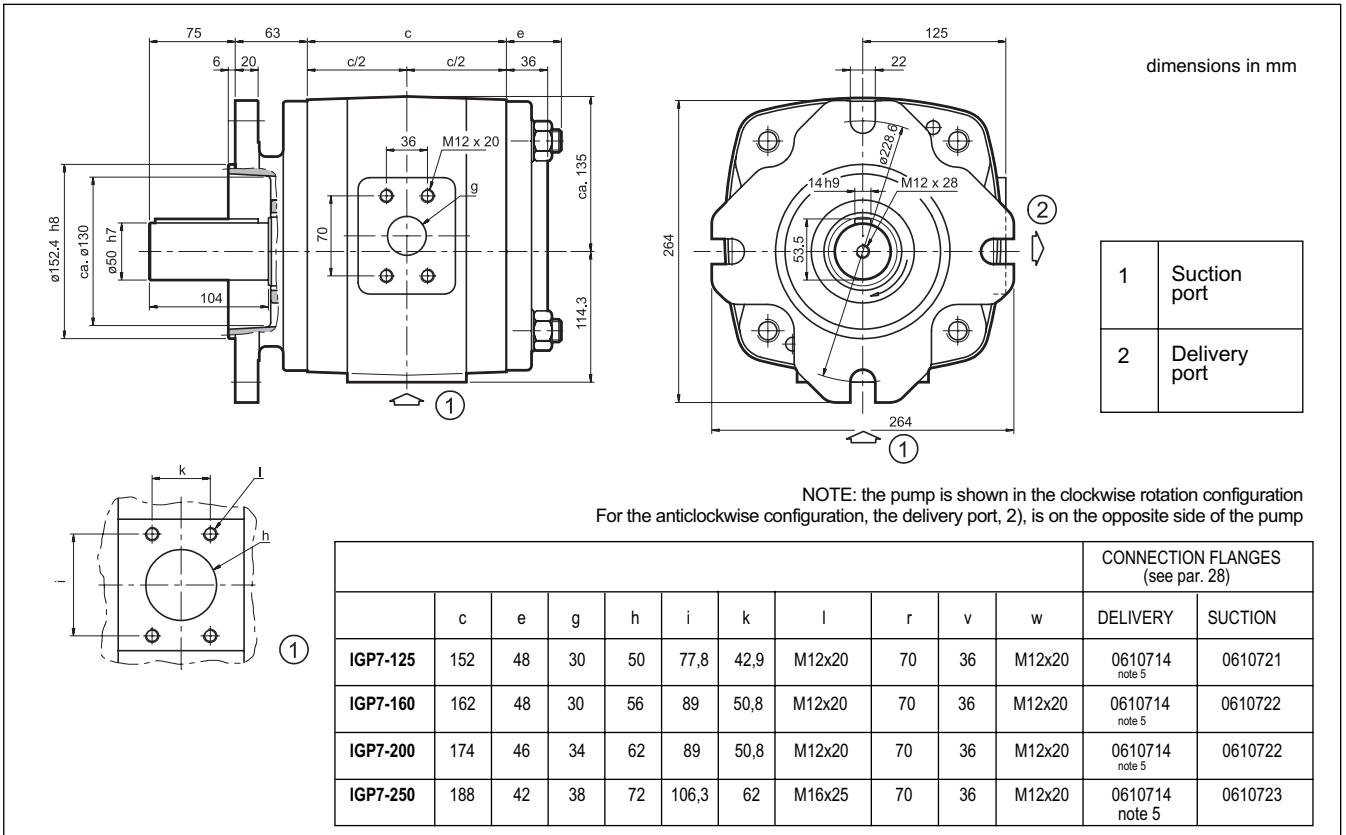

NOTE 5: For applications with delivery pressure greater than 200 bar, it is necessary to use the special connection flange, code 0610725.



14 - IGP33 DOUBLE PUMP OVERALL AND MOUNTING DIMENSIONS

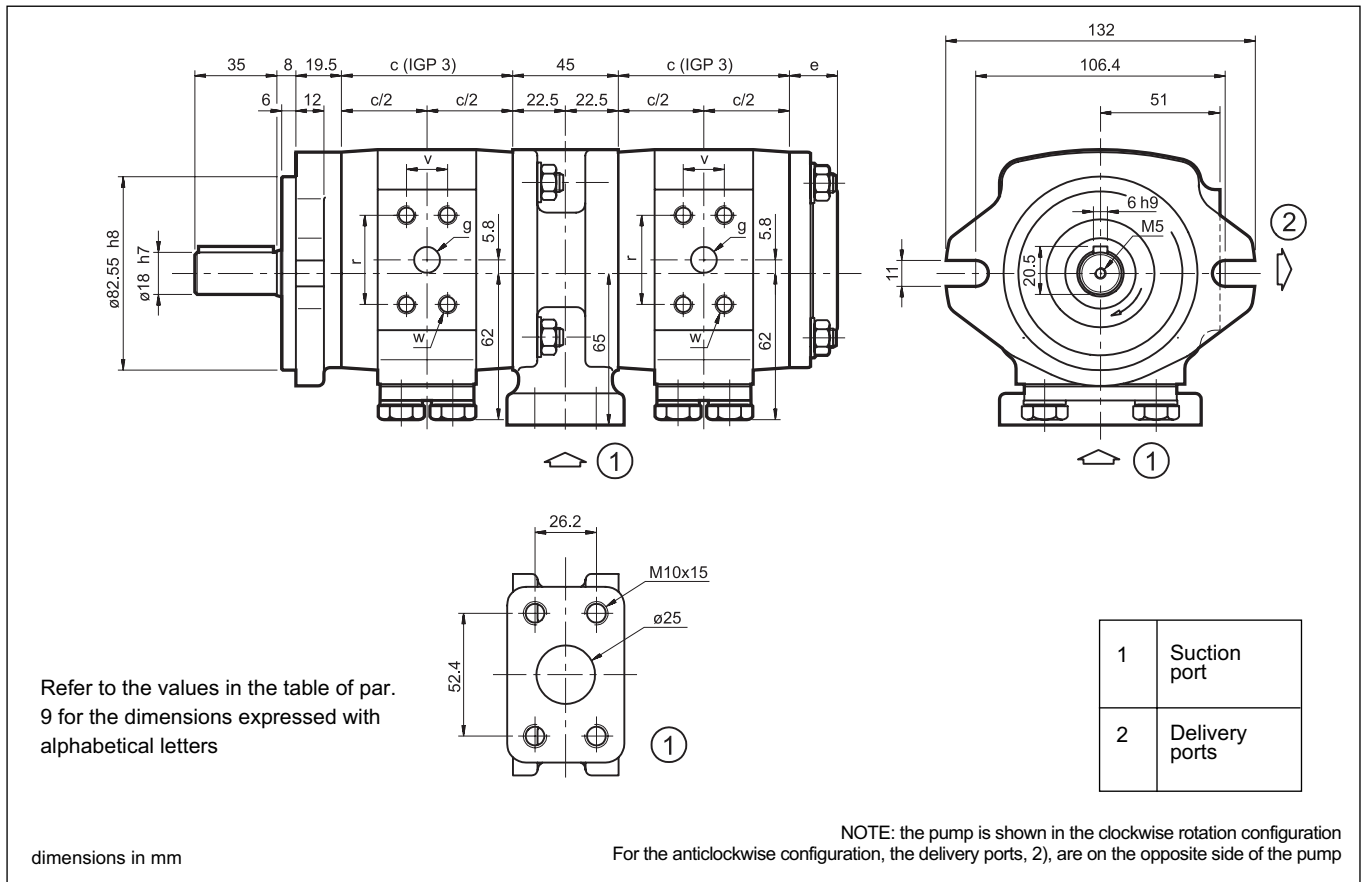

15 - IGP43 DOUBLE PUMP OVERALL AND MOUNTING DIMENSIONS

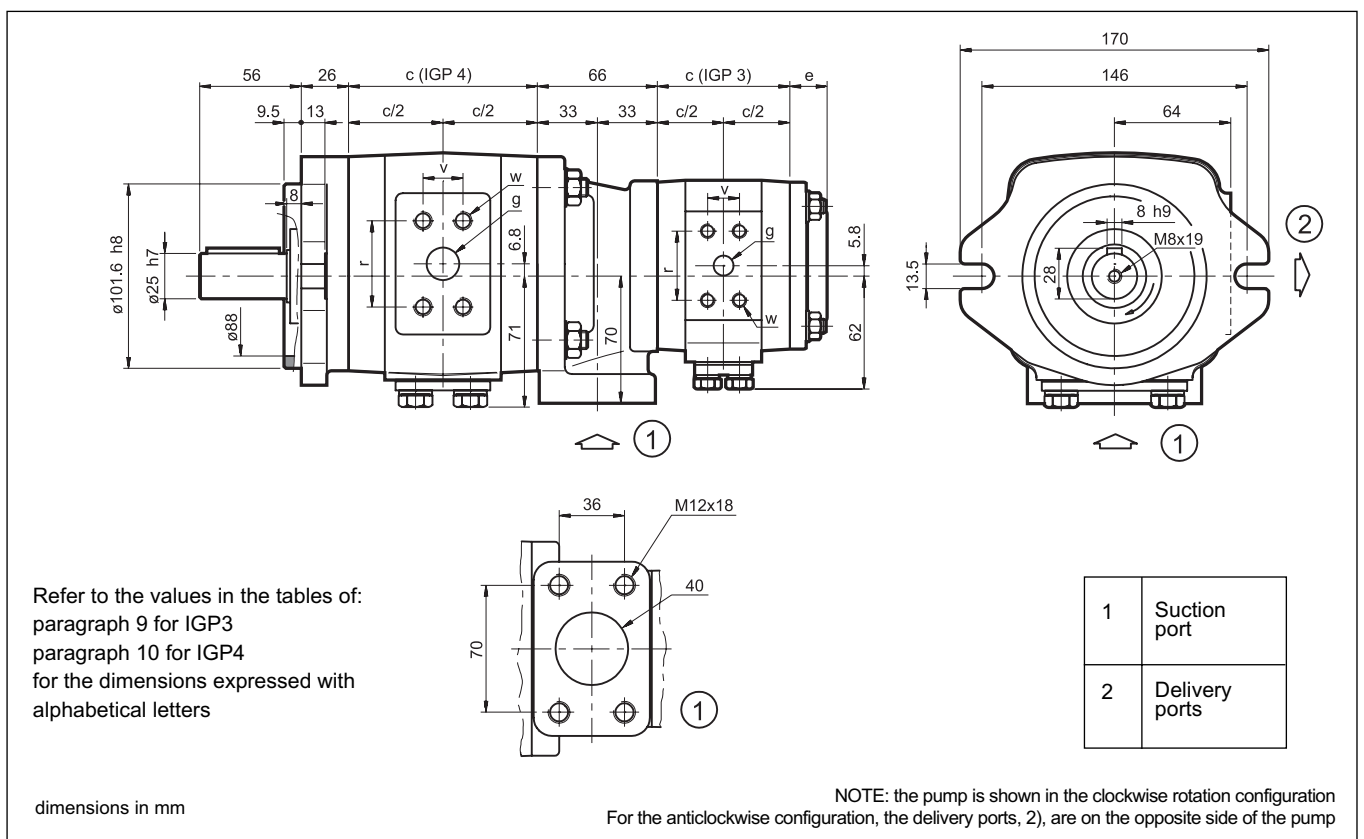



16 - IGP44 DOUBLE PUMP OVERALL AND MOUNTING DIMENSIONS

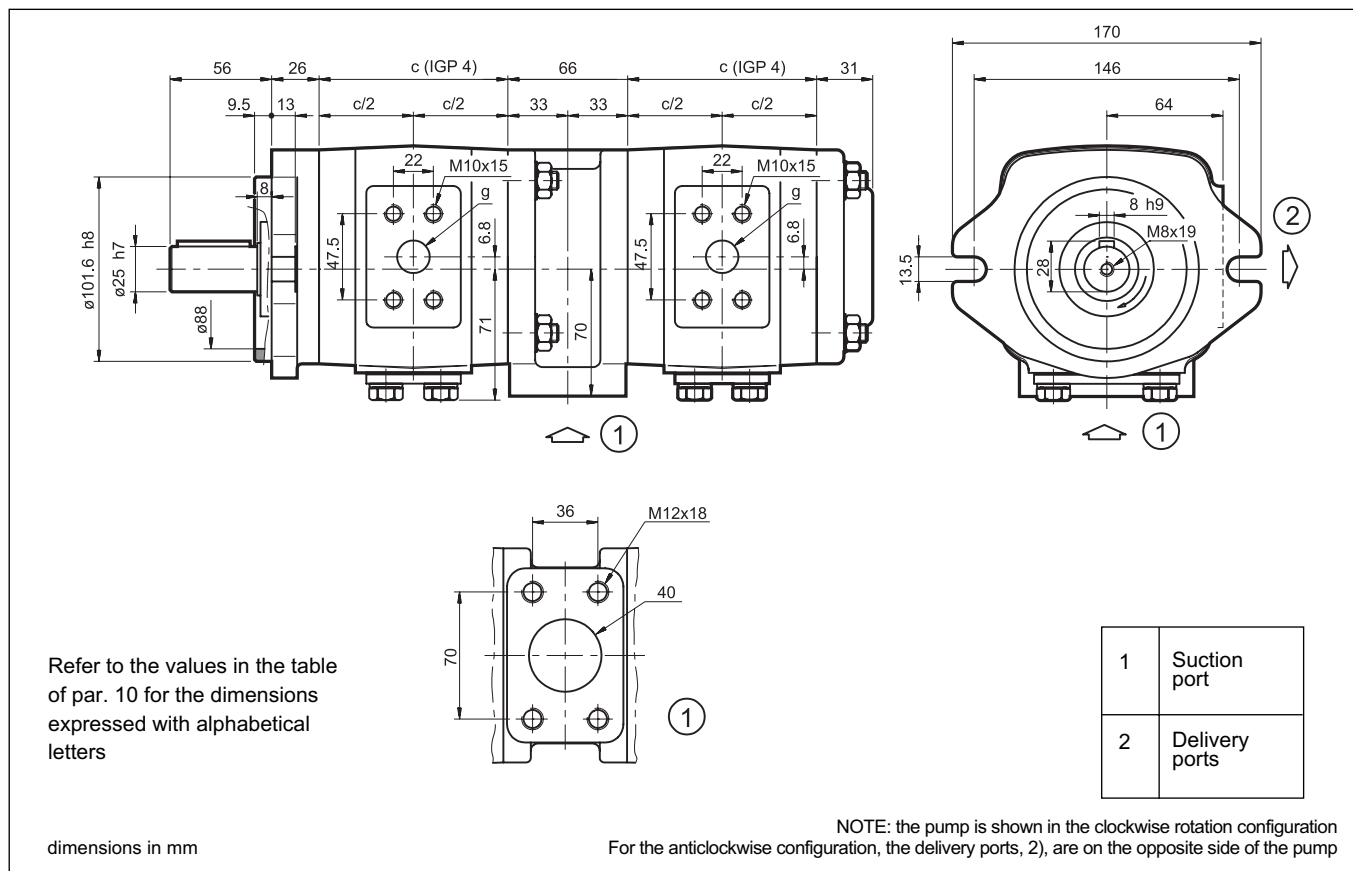

17 - IGP53 DOUBLE PUMP OVERALL AND MOUNTING DIMENSIONS

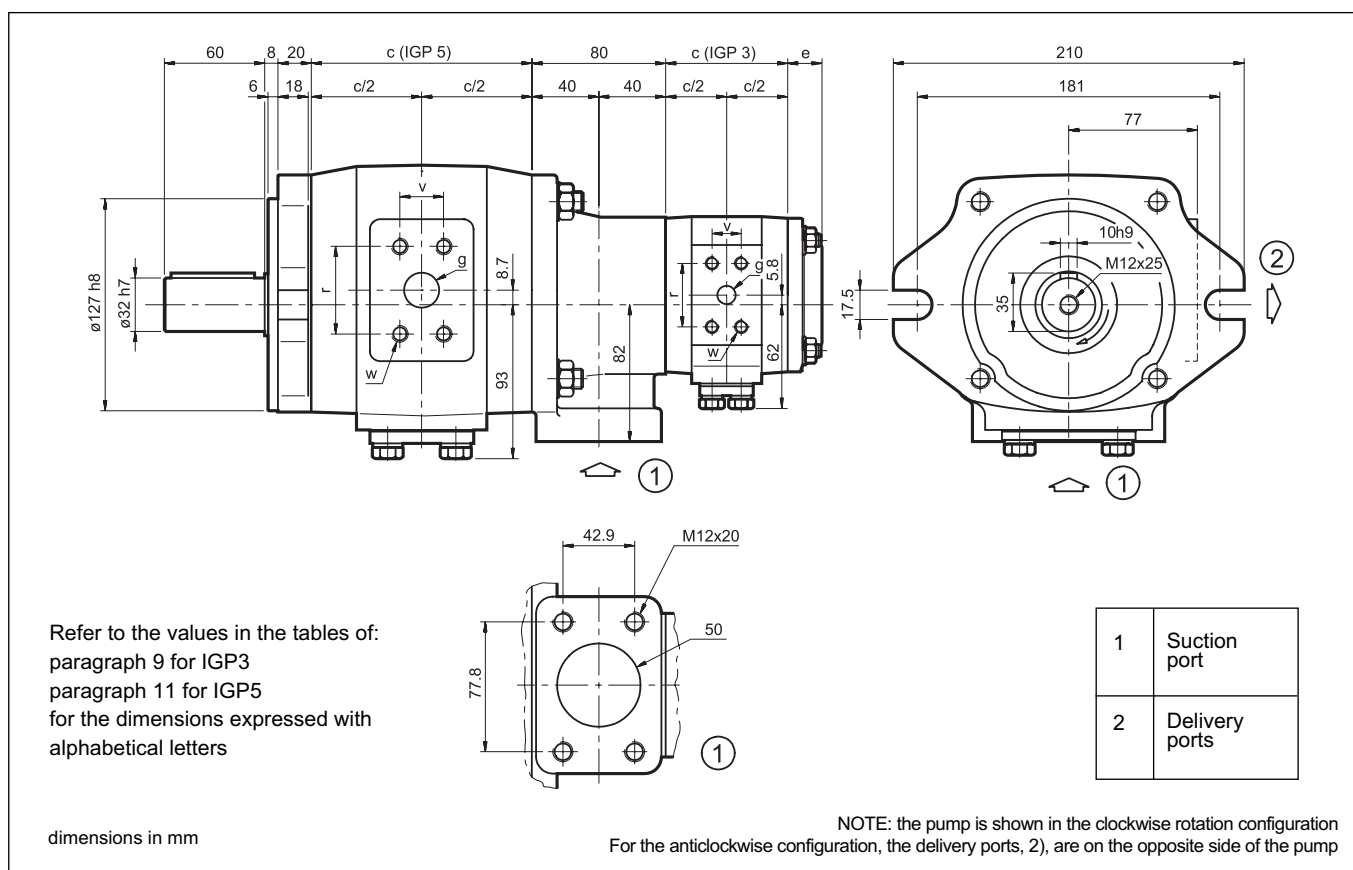



18 - IGP54 DOUBLE PUMP OVERALL AND MOUNTING DIMENSIONS

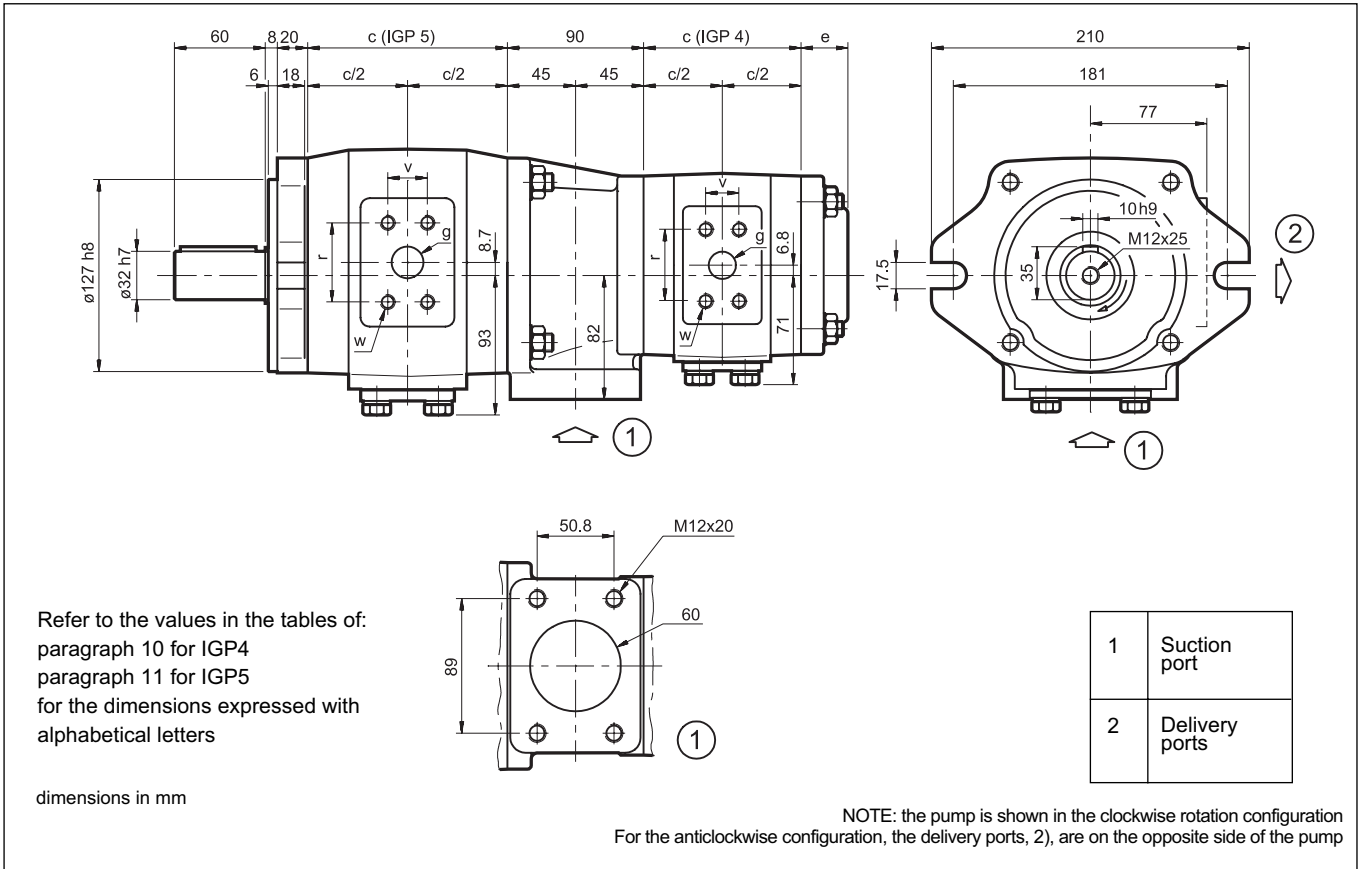

19 - IGP55 DOUBLE PUMP OVERALL AND MOUNTING DIMENSIONS

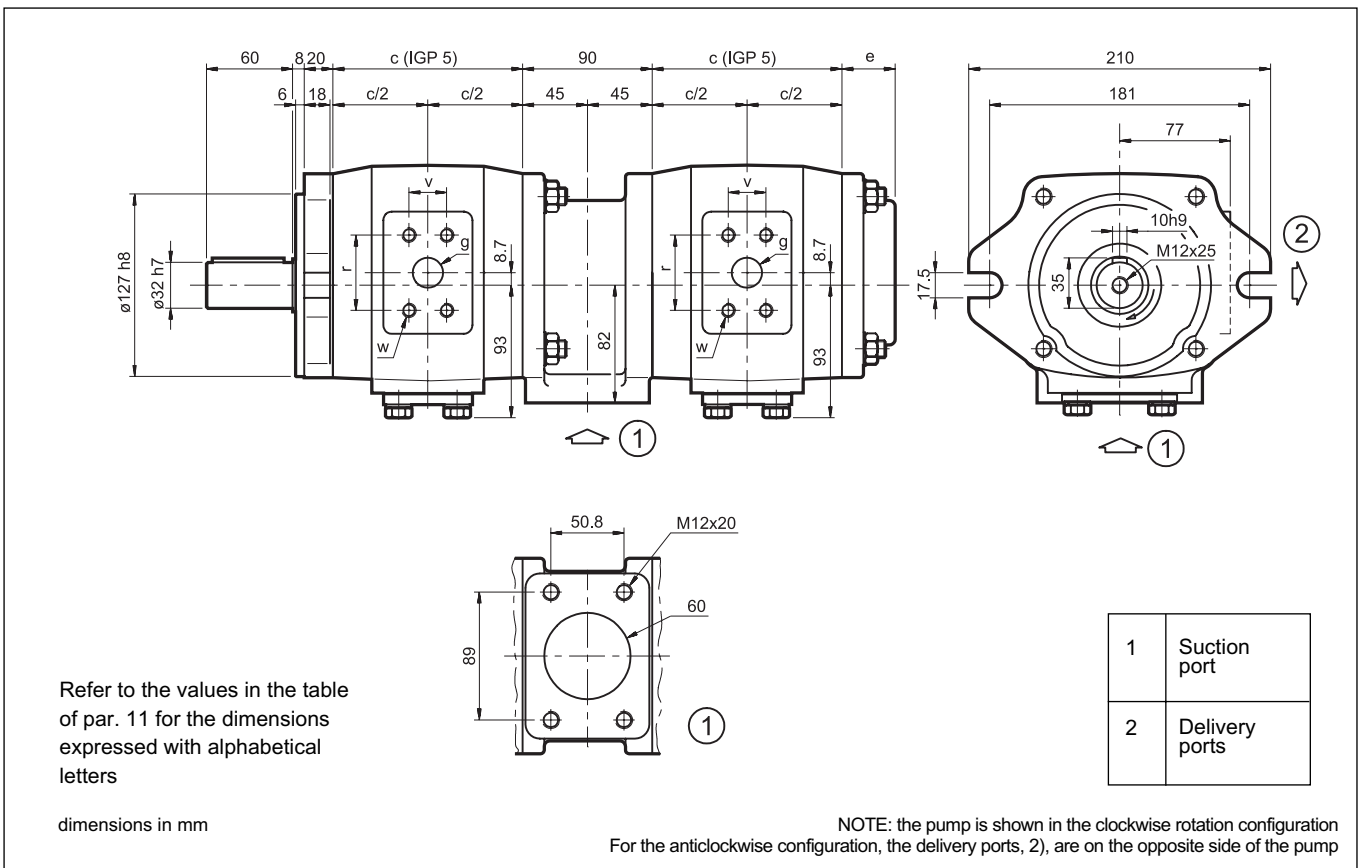



20 - IGP64 DOUBLE PUMP OVERALL AND MOUNTING DIMENSIONS

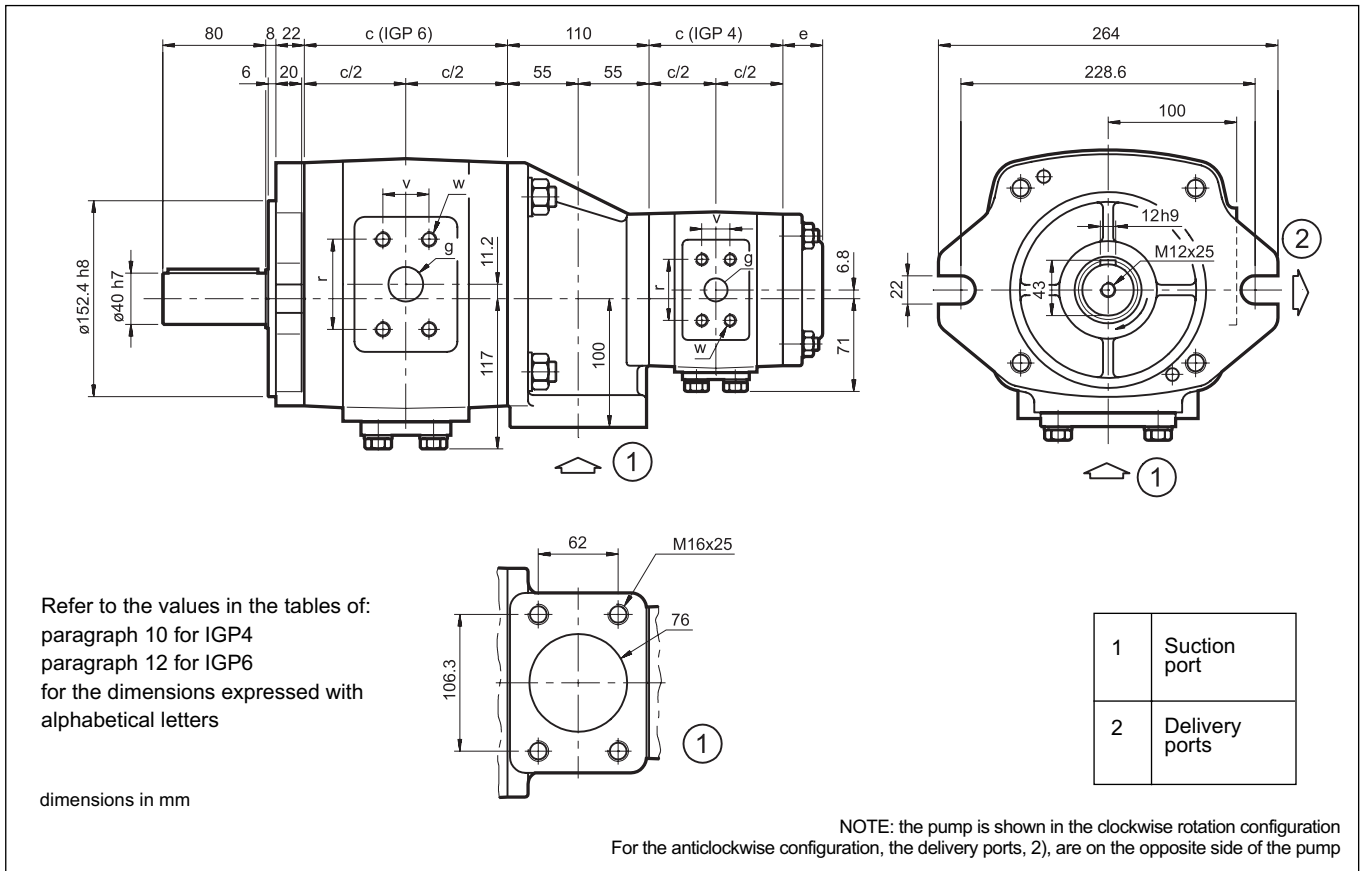

21 - IGP65 DOUBLE PUMP OVERALL AND MOUNTING DIMENSIONS

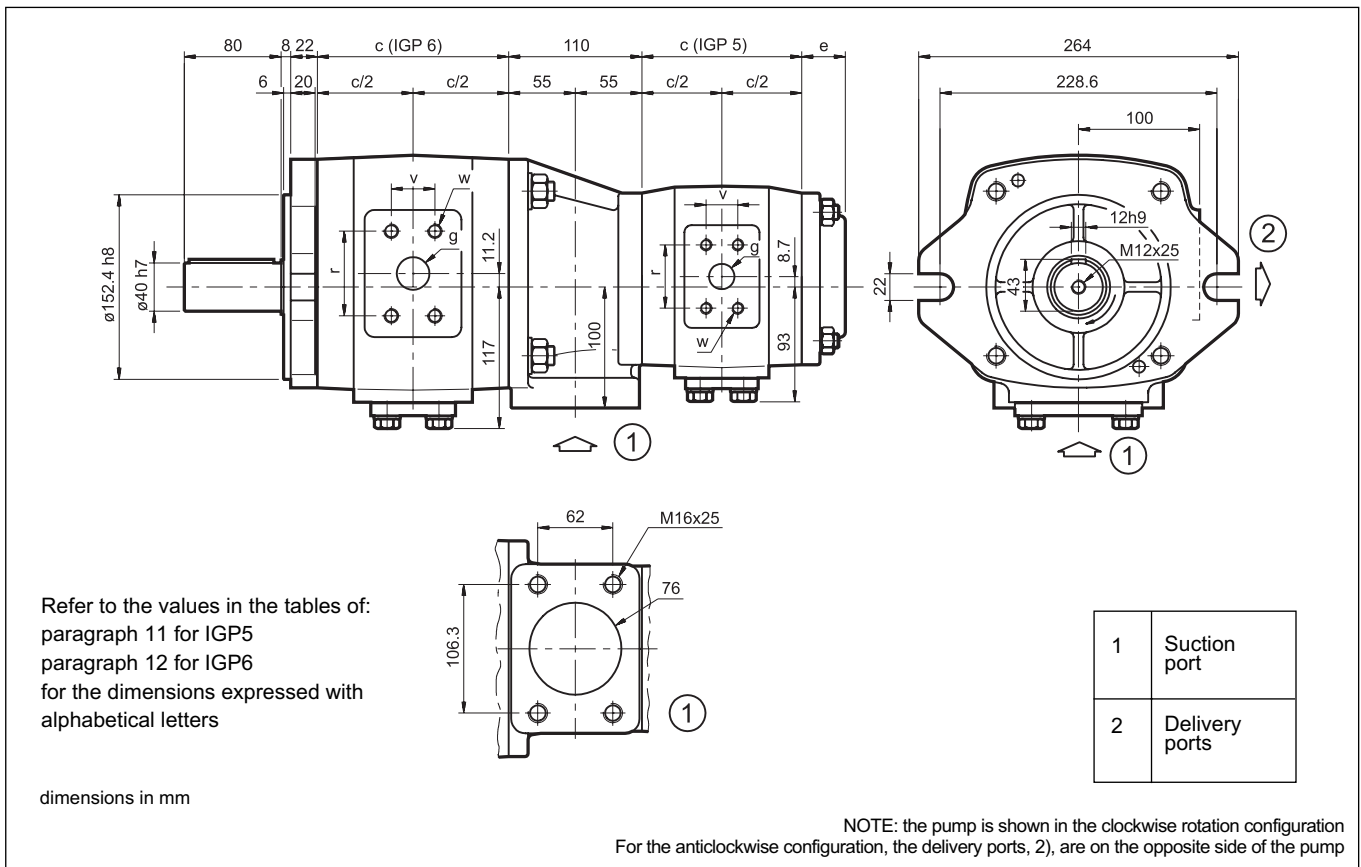



22 - IGP66 DOUBLE PUMP OVERALL AND MOUNTING DIMENSIONS

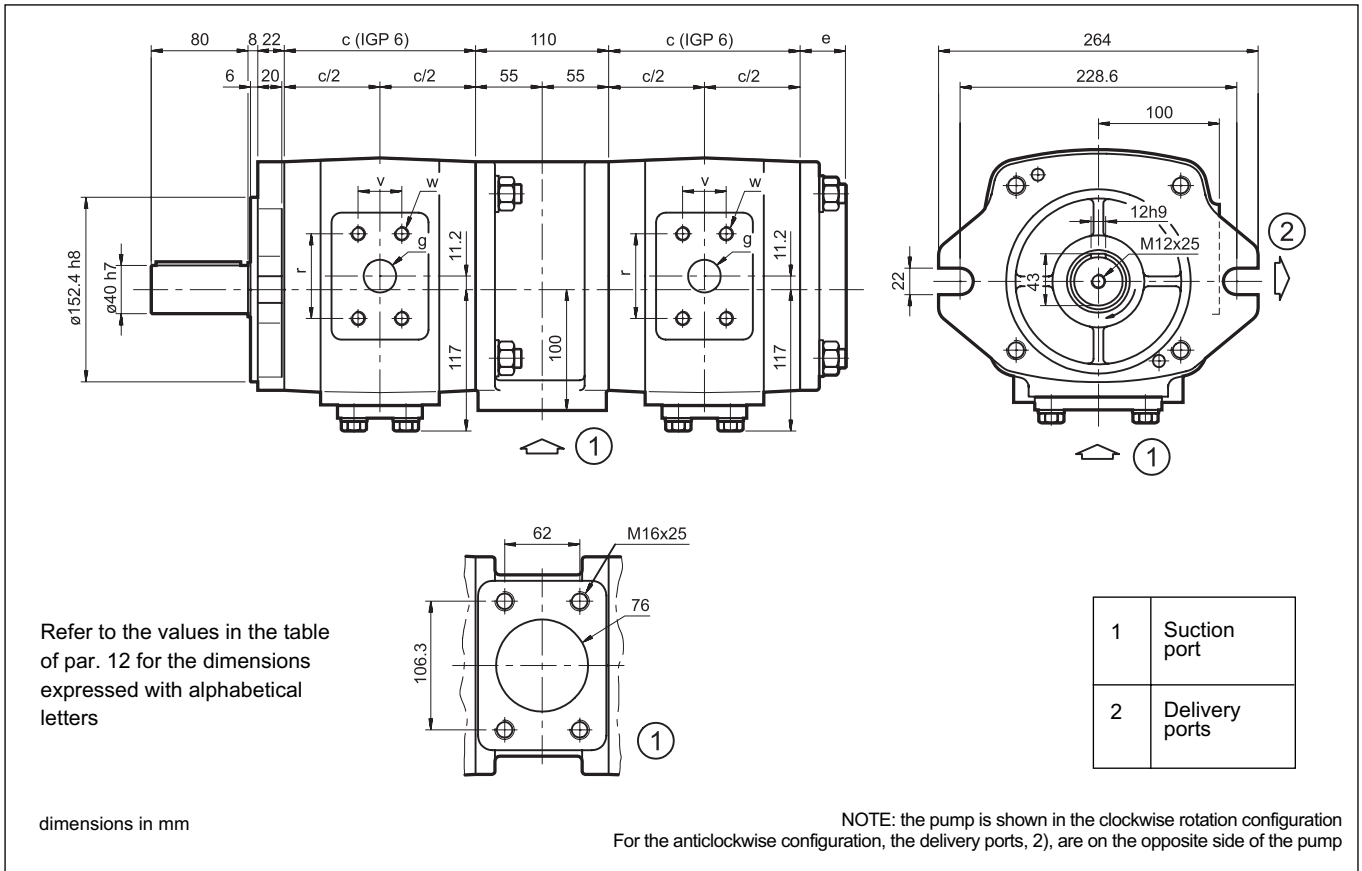

23 - IGP75 DOUBLE PUMP OVERALL AND MOUNTING DIMENSIONS

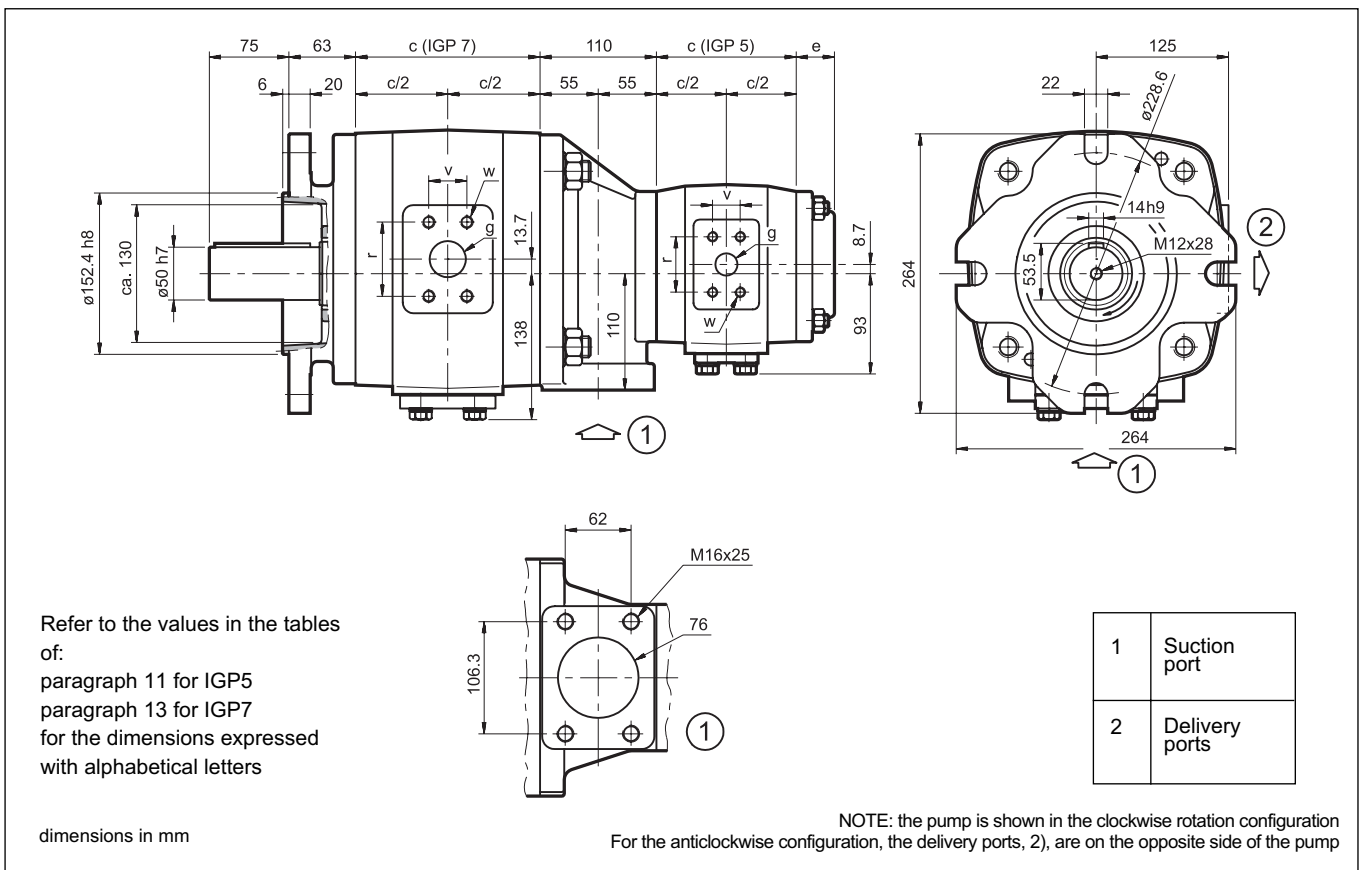



24- IGP76 DOUBLE PUMP OVERALL AND MOUNTING DIMENSIONS

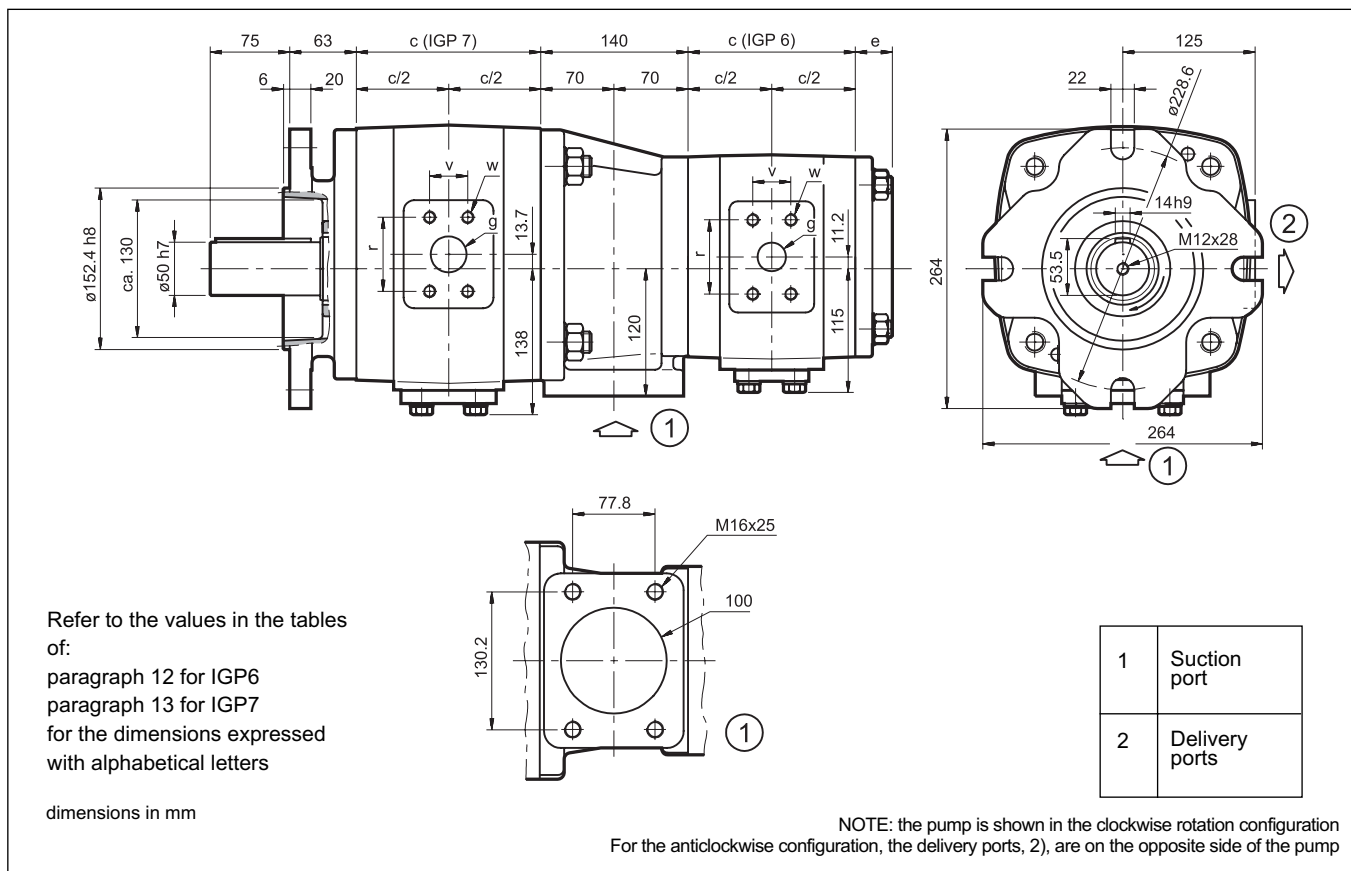

25- IGP77 DOUBLE PUMP OVERALL AND MOUNTING DIMENSIONS

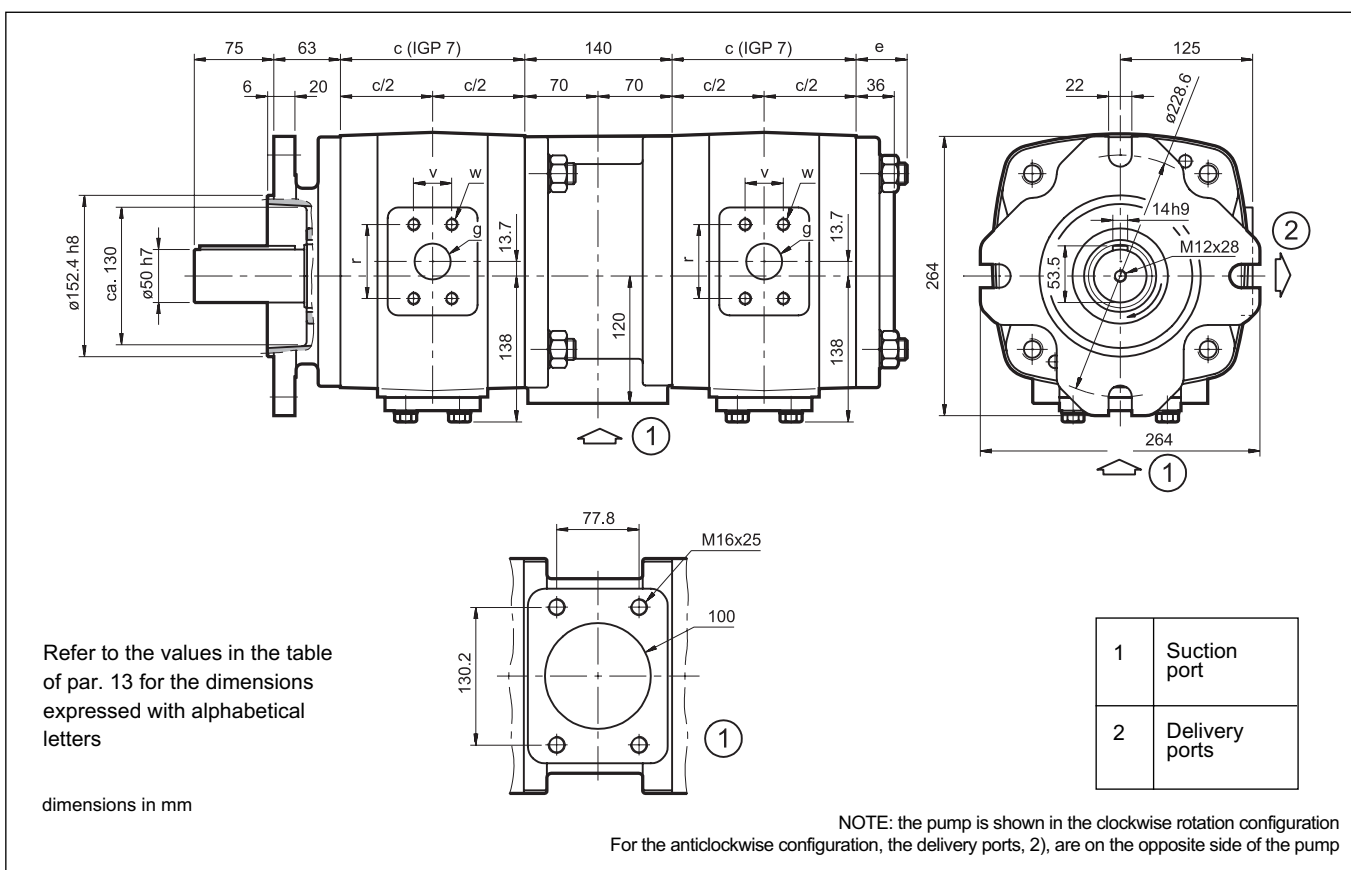



26 - INSTALLATION

- The IGP pumps can be installed with the shaft oriented in any position.
- Prior to putting the pump into operation, check that the rotation direction of the motor is according to the direction of the arrow marked on the pump body.
- The suction line must be sized so that the speed of the fluid does not exceed 1 m/s (1,5 m/s with positive pressure at the pump inlet).
The pump start up, especially at a cold temperature, should occur with the pump unloading.
Any bends and restrictions or an excessive line length can impair correct working of the pump.
The height of suction from the bottom of the tank must not be less than 50 mm.
- The IGP pumps are self-priming in the entire operating speed range specified. At the first start-up of the pump, it is necessary to vent the air from the delivery line.
If a check valve with cracking pressure of >1 bar is installed on the delivery line, it is necessary to vent the air from the circuit branch between the check valve and the pump at the time of start-up.
- The motor-pump connection must be carried out directly with a flexible coupling.
Consult our technical dept. for installations that generate axial or radial loads on the pump shaft.
The coupling must be mounted without axially forcing the pump shaft. Be sure that the joint coupling diameter be made with a K7 tolerance.
- Refer to paragraph 2.3 for the characteristics and installation of the filtering elements.



27 - MAXIMUM APPLICABLE TORQUE

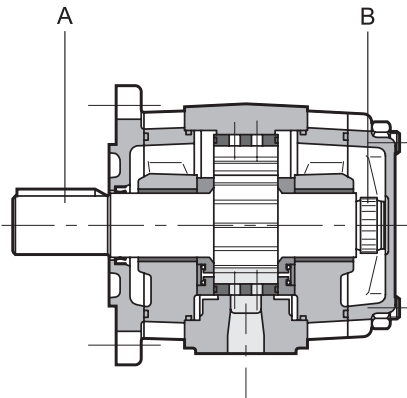

PUMP SIZE	MAX. TORQUE APPLIED TO THE SHAFT [Nm]	
	PRIMARY SHAFT A	SECONDARY SHAFT B
IGP3	160	80
IGP4	335	190
IGP5	605	400
IGP6	1050	780
IGP7	1960	1200

NOTE: The pumps must be connected in order of decreasing displacement and size.

27.1 - Maximum applicable torque for double pumps

In the case of double pumps, even of the same displacement, each pump can operate at the maximum performances specified in par. 3.

27.2 - Maximum applicable torque for multiple pumps

The torque (M) at the inlet of each pump is given from the following equation:

$$M = \frac{9549 \cdot N}{n} = [\text{Nm}]$$

where the absorbed power (N) is given from:

$$N = \frac{Q \cdot \Delta p}{600 \cdot \eta_{\text{tot}}} = [\text{kW}]$$

n = rotation speed [rpm]

Q = delivery [l/min]

Δp = differential pressure on the pump [bar]

η_{tot} = total efficiency (noted from the relative diagrams in par. 4-5-6-7-8)

or is calculated from the ABSORBED POWER diagrams (see par. 4-5-6-7-8).

In the case of multiple pumps, the torque of the single pump must be added to the torque generated by the downstream pumps.

The torque value thus calculated for each pump must be less than the relative value specified in the above table, taking the following into consideration:

1st pump = refer to the specified values for primary shaft A

2nd, 3rd, 4th pump = refer to the specified values for secondary shaft B

In the event the calculated torque values are greater than the values shown in the table, it is necessary to reduce the operating pressure or substitute the overloaded pump with one that can support the required torque.



28 - SAE J518 c code 61 CONNECTION FLANGES

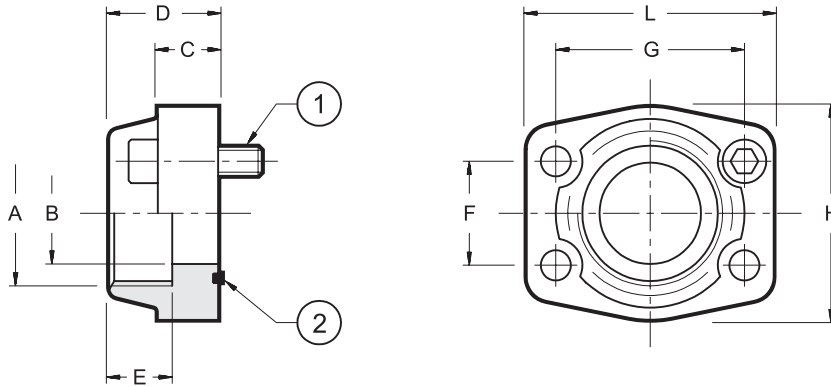

dimensions in mm

Flange code	Flange description	P ^{max} [bar]	∅A	∅B	C	D	E	F	G	H	L	1 4 bolts	2
0610718	SAE - 1/2"	345	1/2" BSP	13	16	36	19	17,5	38,1	46	54	M8 x 30	OR 4075
0610719	SAE - 3/4"	345	3/4" BSP	19	18	36	19	22,2	47,6	50	65	M10 x 35	OR 4100
0610713	SAE - 1"	345	1" BSP	25	18	38	22	26,2	52,4	55	70		OR 4131
0610720	SAE - 1 1/4"	276	1 1/4" BSP	32	21	41	22	30,2	58,7	68	79		OR 4150
0610714	SAE - 1 1/2"	207	1 1/2" BSP	38	25	45	24	35,7	70	78	94	M12 x 45	OR 4187
0610725	SAE - 1 1/2"	345	1 1/2" BSP	38	36	50	25	36	70	80	95	M12 x 55 12K	OR 4187
0610721	SAE - 2"	207	2" BSP	51	25	45	30	43	77,8	90	102	M12 x 45	OR 4225
0610722	SAE - 2 1/2"	172	2 1/2" BSP	63	25	50	30	50,8	89	105	116		OR 4275
0610723	SAE - 3"	138	3" BSP	73	27	50	34	62	106,4	124	134	M16 x 50	OR 4437
0610726	SAE - 4"	34	4" BSP	99	27	48	34	77,8	130,2	146	162		OR 4437

The fastening bolts and the O-Rings must be ordered separately.



DIPLOMATIC OLEODINAMICA SpA
20025 LEGNANO (MI) - P.le Bozzi, 1 / Via Edison
Tel. 0331/472111-472236 - Fax 0331/548328