

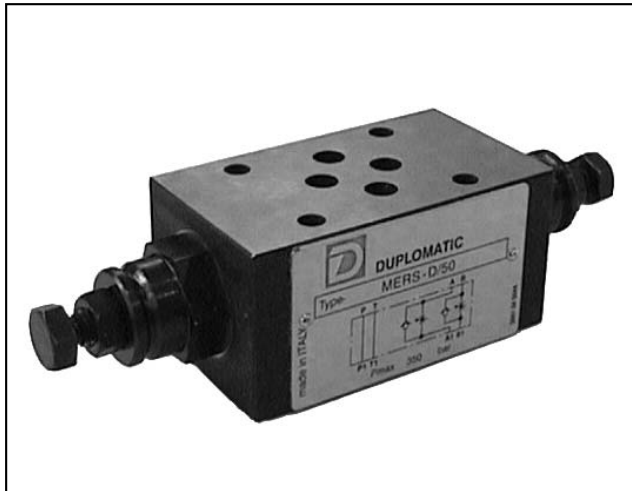

DIPLOMATIC
HYDRAULICS

64 200/107 ED



MERS

FLOW RESTRICTOR VALVE

SERIES 50

MODULAR VERSION

ISO 4401-03 (CETOP 03)

p max 350 bar
Q max (see table of performances)

MOUNTING INTERFACE

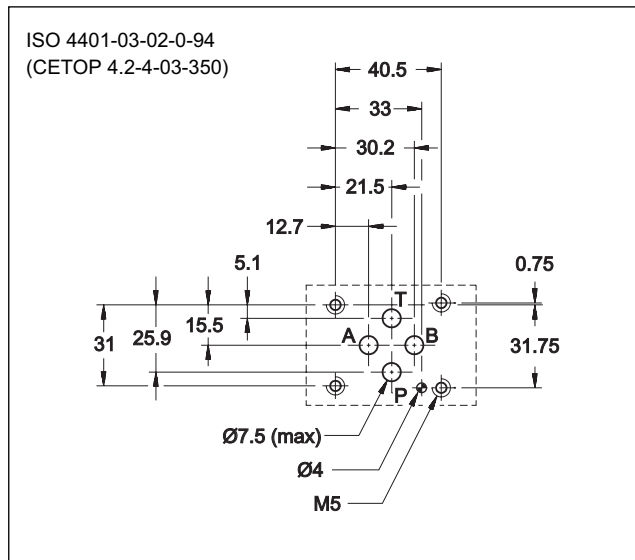

OPERATING PRINCIPLE

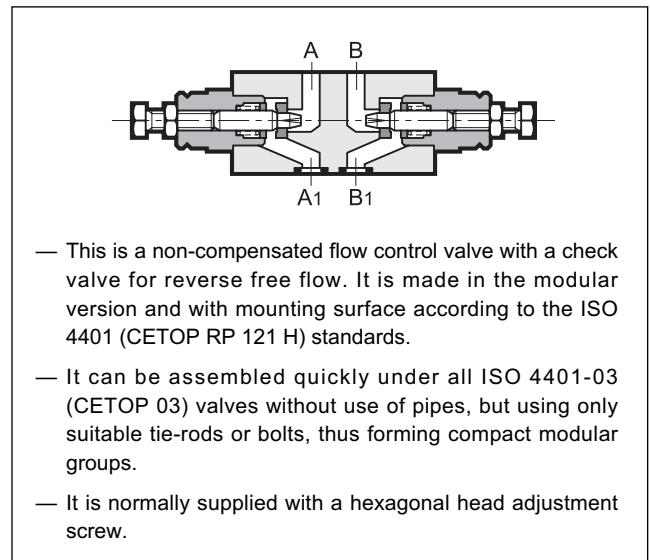

CONFIGURATIONS (see Hydraulic symbols table)

- Configuration "SA": Used when control of the flow exiting from the actuator on line A is desired.
- Configuration "SB": Used when control of the flow exiting from the actuator on line B is desired.
- Configuration "D": Allows an independent flow control exiting from the two chambers of the actuator.
- Configuration "RD": Allows an independent flow control entering in the two chambers of the actuator.
- All the configurations have an incorporated check valve that allows reverse free flow (cracking pressure of 0,5 bar).

PERFORMANCES (measured with mineral oil of viscosity 36 cSt at 50°C)

Maximum operating pressure	bar	350
Check valve cracking pressure		0,5
Maximum flow rate in the controlled lines	l/min	50
Maximum flow rate in the free lines		75
Min. controlled flowrate with Δp 10 bar		$\leq 0,060$
Ambient temperature range	°C	-20 / +50
Fluid temperature range	°C	-20 / +80
Fluid viscosity range	cSt	10 ÷ 400
Fluid contamination degree	According to ISO 4406:1999 class 20/18/15	
Recommended viscosity	cSt	25
Mass:	kg	1,3

HYDRAULIC SYMBOLS

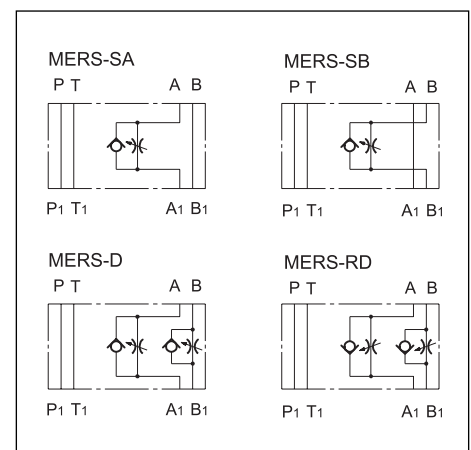



1 - IDENTIFICATION CODE

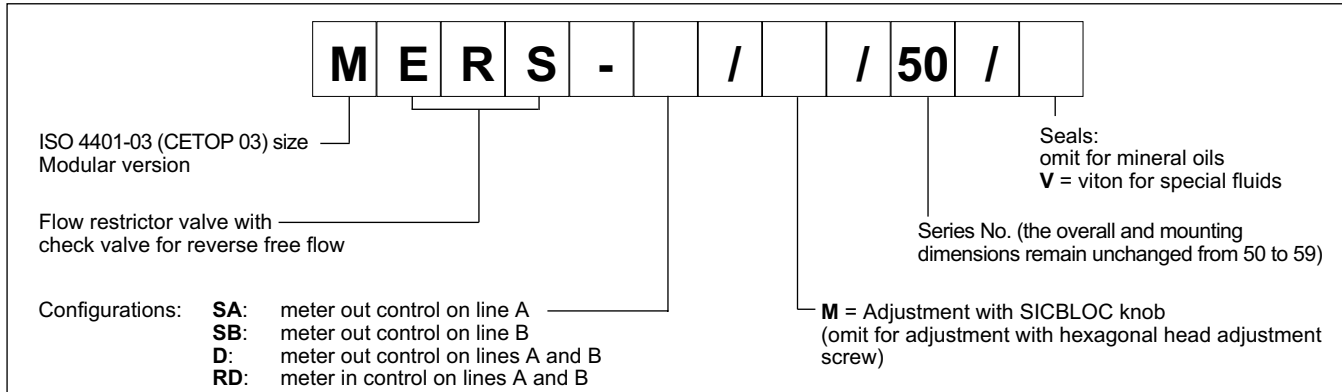

2 - CHARACTERISTIC CURVES (values obtained with viscosity of 36 cSt at 50°C)

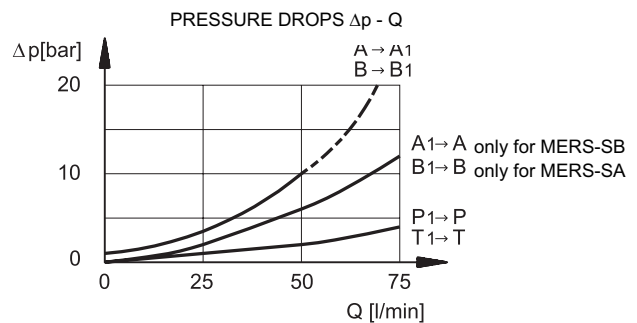
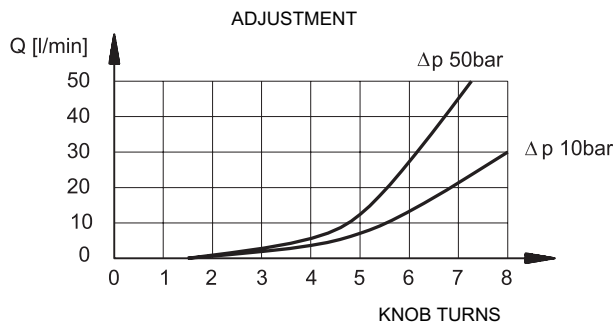

3 - HYDRAULIC FLUIDS

Use mineral oil-based hydraulic fluids HL or HM type, according to ISO 6743-4. For these fluids, use NBR seals. For fluids HFDR type (phosphate esters) use FPM seals (code V). For the use of other kinds of fluid such as HFA, HFB, HFC, please consult our technical department. Using fluids at temperatures higher than 80 °C causes a faster degradation of the fluid and of the seals characteristics. The fluid must be preserved in its physical and chemical characteristics.

4 - OVERALL AND MOUNTING DIMENSIONS

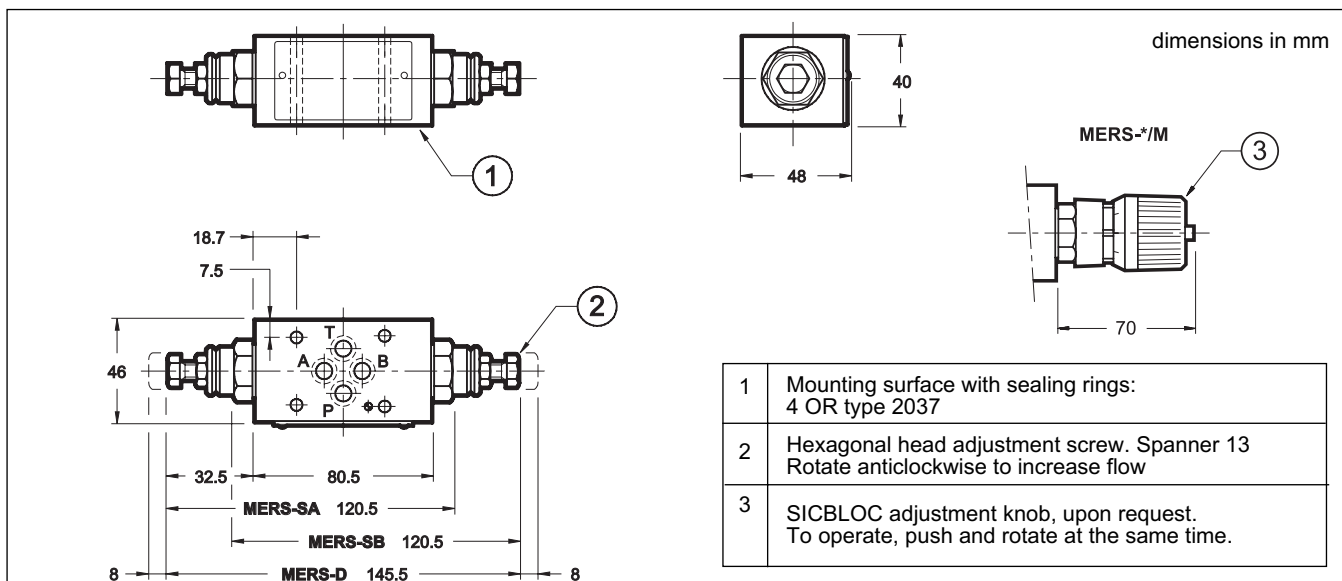

	<p style="text-align: center;">DIPLOMATIC OLEODINAMICA SpA</p> <p style="text-align: center;">20025 LEGNANO (MI) - P.le Bozzi, 1 / Via Edison Tel. 0331/472111 - Fax 0331/548328</p>
--	---