



DIPLOMATIC
HYDRAULICS

61 300/107 ED



RQ4M

PILOT OPERATED PRESSURE RELIEF VALVE

SERIES 51

MODULAR VERSION
ISO 4401-05 (CETOP 05)

p max 320 bar
Q max 100 l/min

MOUNTING INTERFACE

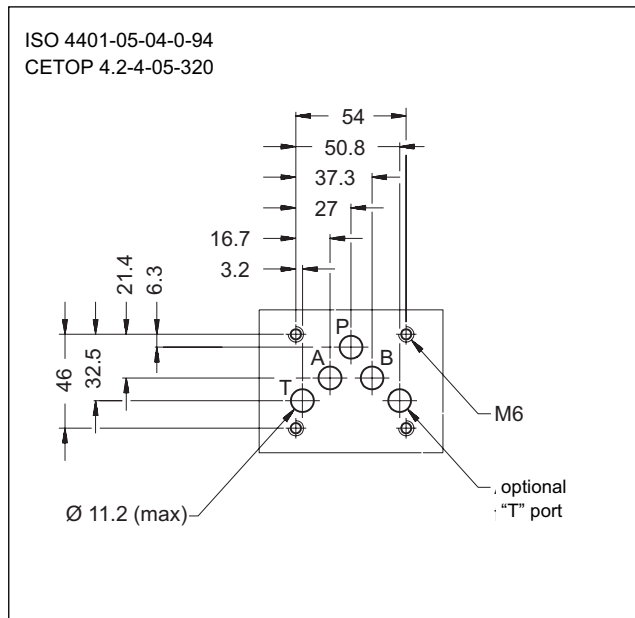

OPERATING PRINCIPLE

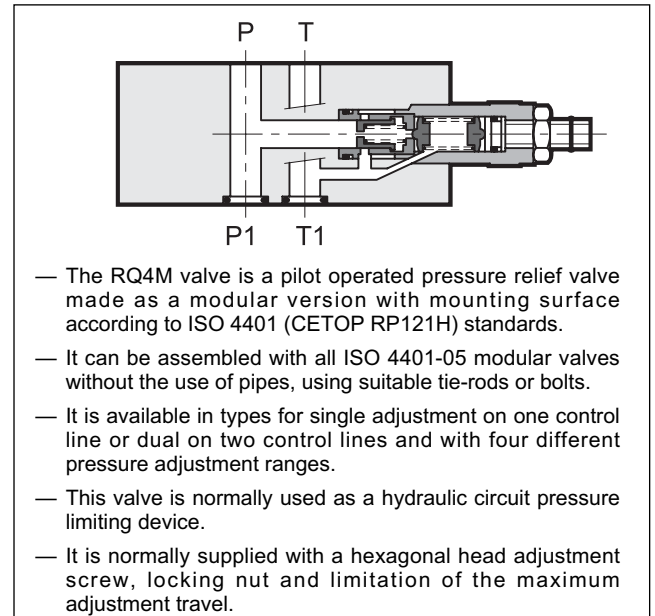

CONFIGURATIONS (see Hydraulic symbols table)

- “SP”: controls the pressure on line P with discharge in T.
- “SAT”: controls the pressure on line A with discharge in T.
- “DT”: controls the pressure on lines A-B with discharge in T.
- “D”: controls the pressure on lines A-B with crossed discharges.

PERFORMANCES (measured with mineral oil of viscosity 36cSt at 50°C)

Maximum operating pressure	bar	320
Minimum controlled pressure	bar	see $\Delta p - Q$ diagram
Maximum flow rate in the controlled line and in the free lines	l/min	100
Ambient temperature range	°C	-20 / +50
Fluid temperature range	°C	-20 / +80
Fluid viscosity range	cSt	10 ÷ 400
Fluid contamination degree	According to ISO 4406:1999 class 20/18/15	
Recommended viscosity	cSt	25
Mass: RQ4M-SP / RQ4M-SAT	kg	2,8
RQ4M-DT / RQ4M-D	kg	3,6

HYDRAULIC SYMBOLS

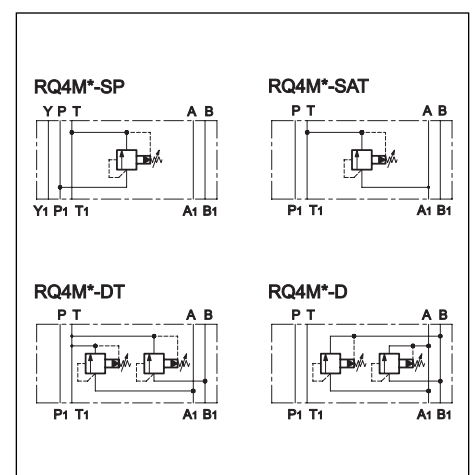



1 - IDENTIFICATION CODE

R	Q	4	M	-	/	/	51	/	
----------	----------	----------	----------	----------	----------	----------	-----------	----------	--

Pilot operated pressure relief valve

ISO 4401-05 (CETOP 05) size

Modular version

Pressure adjustment range:
3 = up to 70 bar **5** = up to 210 bar
4 = up to 140 bar **6** = up to 320 bar

Configurations:
SP: single on line P with discharge in T
SAT: single on line A with discharge in T
DT: double on lines A-B with discharge in T
D: double on lines A-B with crossed discharges

Seals:
omit for mineral oils
V = viton for special fluids

Series No. (the overall and mounting dimensions remain unchanged from 50 to 59)

M1 = Adjustment knob (omit for adjustment with countersunk hex screw)

2 - CHARACTERISTIC CURVES (values obtained with viscosity of 36 cSt at 50°C)

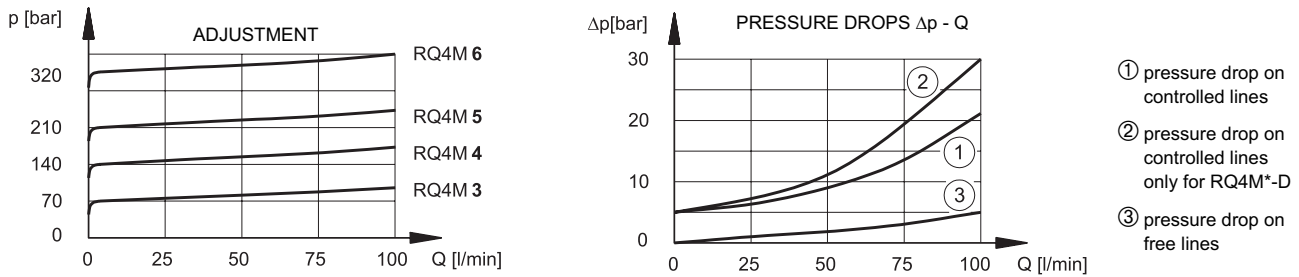

3 - HYDRAULIC FLUIDS

Use mineral oil-based hydraulic fluids HL or HM type, according to ISO 6743-4. For these fluids, use NBR seals. For fluids HFDR type (phosphate esters) use FPM seals (code V). For the use of other kinds of fluid such as HFA, HFB, HFC, please consult our technical department. Using fluids at temperatures higher than 80 °C causes a faster degradation of the fluid and of the seals characteristics. The fluid must be preserved in its physical and chemical characteristics.

4 - OVERALL AND MOUNTING DIMENSIONS

1	Locking nut: spanner 17
2	Countersunk hex adjustment screw: spanner 5. Rotate clockwise to increase pressure
3	Mounting surface with sealing rings: 5 OR type 2050 - 90 Shore (12.42 x 1.78) (+1 OR type 2037 - 90 Shore (9.25 x 1.78) only for RQ4M-SP)
4	Adjustment knob: M1

dimensions in mm

Passing line Y made according to CETOP 4.2-4-P05-320 mounting interface

	DIPLOMATIC OLEODINAMICA SpA 20025 LEGNANO (MI) - P.le Bozzi, 1 / Via Edison Tel. 0331/472111 - Fax 0331/548328
--	---