

Ningbo AUX Electric Co.,Ltd.

 No.1166 North Mingguang Rd,Jiangshan,  
Ningbo,Zhejiang,P.R.China

 [auxcac@mail.auxgroup.com](mailto:auxcac@mail.auxgroup.com)

 <http://www.cnaux.com>

 Tel:+86-574-88220564

The above designs and specifications are  
subject to change without prior notice.  
Final specifications please refer to  
technical specification provided by sales  
representative.

# Commercial AC Expert

2017 Commercial AC Expert

Version:2016/10

# 2017

# GROUP PROFILE

AUKIA is a Second branch of Ningbo AUX Electric Co., Ltd., (AUX CAC) ,which was established in 2001, and now concentrates on a world first-class professional Commercial Air Conditioner manufacturer.

AUX CAC has 8 production lines, the assembly area is up to 19,000 square meters, with the advanced equipment from 26 countries around the world, like Japan HIDIKA, German WAGNER wholly computerized spraying line, and Japan AMADA multi-function punching machine ; AUX CAC 's production capacity is up to 360,000 sets per year. AUX CAC is strictly in line with the quality system (ISO9001:2000) standardized operation. All of the equipment has passed Hefei General Machinery Research Institute inspection.

Cooperating with National Post-Doctoral Research Center and Institute of Refrigeration, AUX CAC owns the most advanced R&D team in the industry to insist on the belief of "Energy-saving, Environmentally-friendly, Green, Healthy"; continuously develop more energy-saving, more intelligent products to improve human living environment and aim to become a global first-class green building solutions leader.

1994 Started RAC Business

1986 Established AUX Group

2004 Got CNAS Certificate

2011 Launched DC Inverter VRF System Globally

2016 Launched Full DC Inverter KRV 5X Overseas

2007 Launched Digital Scroll KRV System





2016 Ningbo AUX Electric Co., Listed (Stock Code: 835523)

2001 Entered The CAC Field



# Product Lineup

## Modular VRF Outdoor Units

Capacity(kW)	Appearance	25.2	28.0	33.5	40.0	45.0	50.4	56.0	Page
KRV 5X	50Hz 	•	•	•	•	•			10
	60Hz 	•	•	•	•	•			10
KRV 4	50Hz 	•	•	•	•	•	•	•	25
	60Hz 	•	•	•	•	•	•	•	25

### KRV 5X

8/10/12HP      14/16HP      18/20/22/24/26/28/30/32HP      34/36/38/40/42/44/46/48HP



50/52/54/56/60/62/64HP



### KRV 4

8/10/12HP      14/16/18HP      20HP      22/24/26/28/30/32/34/36/38HP





40/42/44/46/48/50/52/54/56/58HP      60/62/64/66/68/70/72/74/76/78/80HP













# Product Lineup

## Mini VRF Outdoor Units

Capacity(kW)	Appearance	8	10	12	14	16	22	28	Page
KRV Mini	50Hz 	•	•	•	•	•	•	•	38
	60Hz 	•	•	•	•	•			42

## Indoor Units

Capacity(kW)	Appearance	2.2	2.8	3.6	4.5	5.6	7.1	8.0	9.0	10.0	11.2	12.5	14.0	15.0	Page
One-way Cassette		•	•	•	•	•	•								46
Two-way Cassette		•	•	•	•	•	•								47
Four-way Cassette			•	•	•	•	•	•	•	•	•	•	•		48
Slim Duct		•	•	•	•	•	•								54
Mid ESP Duct					•	•	•	•	•	•	•	•	•	•	55
High ESP Duct											•	•	•	•	58
Ceiling&Floor					•	•	•	•	•	•	•	•	•		62
Wall-mounted		•	•	•	•	•	•								66

Capacity(kW)	Appearance	22.0	28.0	45.0	56.0	Page
High ESP Duct		•	•	•	•	58
Fresh Air Processor		•	•	•	•	60

## Heat Recovery Ventilator

Volume(m³/h)	Appearance	200	300	400	500	600	800	1000	1500	2000	2500	3000	4000	5000	Page
HRV		•	•	•	•	•	•	•	•	•	•	•	•	•	69

# Chiller&FCU

## Mini Chiller



13kW



16kW



28.5kW

## Modular Chiller



H Type  
65/130kW



X Type  
30/65kW



Hydraulic Module  
26-150kW

## Fan Coil Unit

50Hz/60Hz



One-way Cassette  
200-500CFM



Four-way Cassette  
300-1400CFM



Ceiling&Floor  
400-1000CFM



Horizontal Concealed  
200-1400CFM



Wall-mounted  
200-800CFM

# Product Lineup

## Europe Series-Light Commercial



Series	Appearance	Refrigerant	Type	18kBtu/h	24kBtu/h	30kBtu/h	36kBtu/h	42kBtu/h	48kBtu/h	60kBtu/h	Page
Outdoor Units		R410a	DC Inverter	●	●	●	●	●	●	●	108
Compact Four-way Cassette		R410a	DC Inverter	●							111
Four-way Cassette		R410a	DC Inverter	●	●	●	●	●	●	●	111
Ceiling&Floor		R410a	DC Inverter	●	●	●	●	●	●	●	114
Mid ESP Duct		R410a	DC Inverter	●	●	●	●	●	●	●	117

## Europe Series-Free Match



Series	Appearance	Refrigerant	Type	18kBtu/h	24kBtu/h	27kBtu/h	36kBtu/h	42kBtu/h	Page
1 Drive 2		R410a	DC Inverter	●					120
1 Drive 3		R410a	DC Inverter		●	●			120
1 Drive 4		R410a	DC Inverter				●		120
1 Drive 5		R410a	DC Inverter					●	120

## Tropical 50Hz&60Hz



Series	Appearance	Refrigerant	Type	18kBtu/h	24kBtu/h	30kBtu/h	36kBtu/h	48kBtu/h	60kBtu/h	Page
Outdoor Units		R410a	50Hz	●	●	●	●	●	●	126
		R410a	60Hz	●	●		●	●	●	126
Mid ESP Duct		R410a	50Hz	●	●	●	●	●	●	130
		R410a	60Hz	●	●		●	●	●	130
Four-way Cassette		R410a	50Hz	●	●	●	●	●		134
		R410a	60Hz	●	●		●	●		134

## T1 R410a 50Hz



Series	Appearance	Refrigerant	Type	12kBTu/h	18kBTu/h	24kBTu/h	30kBTu/h	36kBTu/h	48kBTu/h	60kBTu/h	Page
Outdoor Units		R410a	DC Inverter			●	●	●	●	●	138
		R410a	ON/OFF	●	●	●	●	●	●	●	138
Four-way Cassette		R410a	DC Inverter			●	●	●	●	●	140
		R410a	ON/OFF	●	●	●	●	●	●	●	140
Ceiling&Floor		R410a	DC Inverter			●	●	●	●	●	144
		R410a	ON/OFF			●	●	●	●	●	144
Mid ESP Duct		R410a	DC Inverter			●	●	●	●	●	148
		R410a	ON/OFF			●	●	●	●	●	148
High ESP Duct		R410a	ON/OFF						●	●	148
Low ESP Duct		R410a	ON/OFF	●							148

## Large Split Type



Series	Appearance	Type	80kBTu/h	100kBTu/h	Page
Commercial High Esp Duct		R410a	●	●	152
Indoor Duct		R410a	●	●	153
Commercial Floor standing		R410a	●	●	155
Indoor Unit		R410a	●	●	157

## T1 R410a 50Hz&60Hz-Light Commercial



Series	Appearance	Refrigerant	Type	18kBTu/h	24kBTu/h	30kBTu/h	36kBTu/h	42kBTu/h	48kBTu/h	60kBTu/h	Page
Outdoor Units		R410a	DC Inverter	●	●	●	●	●	●	●	158
Four-way Cassette		R410a	DC Inverter	●	●	●	●	●	●	●	161
Ceiling&Floor		R410a	DC Inverter	●	●	●	●	●	●	●	164
Mid ESP Duct		R410a	DC Inverter	●	●	●	●	●	●	●	167

## T1 R410a 50Hz&60Hz-Free Match



Series	Appearance	Refrigerant	Type	18kBTu/h	24kBTu/h	27kBTu/h	36kBTu/h	42kBTu/h	Page
1 Drive 2		R410a	DC Inverter	●					170
1 Drive 3		R410a	DC Inverter		●	●			170
1 Drive 4		R410a	DC Inverter				●		170
1 Drive 5		R410a	DC Inverter					●	170

## Health



Fresh Air Intake

Air outside can be led into the room via a connection pipe, which keeps the indoor air fresh and healthy.



Long-term Filter

The latest long-term filter ensures better air quality. Meanwhile, the cleaning frequency has been decreased, and maintenance is also much easier.



Self-Cleaning

Indoor unit will continue running with special combined mode to blow and dry indoor evaporator after the unit switch off so as to keep clean and healthy.

## Comfort



Anti-Cold-Air

When starting the heating operation, the fan speed is regulated automatically from the lowest speed to the preset level. This function can prevent cold air from blowing out at the beginning of the operation, which avoids the discomfort to the user.



Follow Me

Temperature sensor built in the remote control will sense its surrounding temperature, so the unit can achieve accurate and comfortable temperature control just like the air conditioner is following you.



Fast Cooling/Heating

Startup at high frequency increases cooling/heating capacity and reduces time to reach set temperature, thus you can enjoy cooling and heating in seconds.



Auto swing

Distributes cool/warm air to maximum area by moving horizontal and vertical flags automatically.



Independent Dehumidification

With the independent dehumidification function, the unit can efficiently dehumidify the room and give you more comfort.



3D Air Flow

Combine vertical and horizontal auto swing to ensure an even distribution of air flow throughout the room.



Dimmer

Press this button to shut off the display light on the front panel.



Silent

Indoor fan will run at super breeze speed and indoor noise level can be extremely low when the unit enters silent mode operation.

## Reliability



Self-diagnosis Function

Once abnormal operation or parts failure happen, the unit will monitor the failures, the microcomputer of air conditioner will switch off and protect the system automatically when it happens. Meanwhile, the error or protection code will be displayed on the indoor unit.



Low Ambient Cooling

With special designed PCB, outdoor fan speed can be changed automatically according to condensation temperature. The air conditioner can run cooling operation even when the outdoor ambient temperature down to-15 C.



Intelligent Defrosting

Normal defrost function can only be operated in certain time, but AUKIA commercial air conditioner's intelligent defrost can start automatically according to the surrounding condition.



Compressor Heating Belt

Auxiliary heating belt can increase compressor oil temperature in winter and prevent defrosting water accumulated, which improves heat transfer efficiency.



No Frosting Chassis

The unique pipeline design makes the temperature on chassis higher than normal units, and it prevents defrosting water accumulated, which improves heat transfer efficiency and solves the drainage problem.



Golden Fin

Effectively prevent bacteria breeding and improve heat transfer efficiency. The unique anti-corrosive golden coating on the condenser can withstand the rain, salty air and other corrosive elements.



Optional Electric Heater

Built-in Auxiliary electric heater as option, the heating performance will be more powerful.



Fire-proof Electric Box

Electrical control box adopts new design, which can meet the higher fire safety requirement to prevent the internal fire due to the electric spark accident.

# Energy Saving



**180° Sine Wave Control**

With considerable advantages, DC Inverter 180° sine wave driving technology has much wider range of frequency and voltage, higher energy efficiency, more smooth running and lower noise.



**0.5W Standby**

Intelligent technology enables AUKIA products to cut energy consumption from normal 5W to 0.5W per hour when standby, which counts 90% of saving.



**Sleep Mode**

The function enables the air conditioner to automatically increase cooling or decrease heating 1°C per hour for the first 2 hours, then holds steady for the next 5 hours, after that it will switch off. This function maintains both energy saving and comfort in night.



**Hydrophilic aluminum fin**

The louvered hydrophilic aluminum foil has improved by more than 10%. There refrigerant inlet and outlet are separated, to ensure the sub-cooling and enhance the cooling capacity.



**Full Process By DC Drive**

DC control, DC Compressor, DC indoor motor, DC outdoor motor, and DC Electronic expansion valve make low noise and high efficiency.

# Convenience



**24-hour Timer**

Users can turn on or turn off the air conditioner at any time in 24 hours with remote controller or wireless controller.



**Built-in Drain Pump**

The built-in pump can lift the condensing water 1200 mm upmost from the drainage pan.



**Dual side Drainage**

Both left and right sides of the indoor unit are possible for drainage hose connection, and it's easy for installation with this function.



**Digital Tube Display**

Easily for the running parameters checking and more convenient for troubleshooting, digital tube displays work status such as indoor temperature, setting temperature, the mode of operation, etc.



**Remote Control**

Help users to control the air conditioner easily, you can design your most comfortable settings with this controller.



**Wired Control**

Help users to control the air conditioner easily, the wired controller can be fixed on the wall and avoid mislaying. It's mainly used for commercial zone and makes air conditioner control more convenient.



**Central Control**

With the control function of weekly timer, zone (or group) setting etc., the centralized controller can control 64 units with RS 485 wire connection and the central control adapter.



**WIFI Control**

With the WIFI control, you can easily turn off the air conditioner outside your house via smart device. Furthermore, you can turn it on before you come back. The indoor unit filter can be taken off to wash easily and it keeps cleaning air all the time.



**Washable Filter**

The indoor unit filter can be taken off to wash easily and it keeps cleaning air all the time.



**Auto Restart Function**

If the air conditioner breaks off unexpectedly due to the power cut, it will restart with the previous setting mode automatically when the power resume.

# Nomenclature

## Indoor Unit

KRV NC 96 H - 4 R1 A

Design Series Code

Refrigerant Type:  
R1: R410a.

R22 Omitted

Power Supply:  
2: 208-230V~, 1Ph, 60Hz  
5: 380-415V~, 3Ph, 50Hz  
9: 208-230V~, 3Ph, 60Hz

4: 220-240V~, 1Ph, 50Hz  
6: 380-415V~, 3Ph, 60Hz  
Q: 220-240V~, 1Ph, 50Hz/60Hz

H: Cooling & Heating

C: Cooling Only

Cooling Capacity (k Btu/h)

Indoor Unit Type:  
NA: One-Way Cassette  
NC: Four-Way Cassette  
NL: Low ESP Duct  
NH: High ESP Duct  
NF: Fresh Air Processer

NB: Two-Way Cassette  
NE: Ceiling&Floor  
NM: Mid ESP Duct  
NW: Wall-Mounted

AUKIA Refrigerant Variable AC

## Outdoor Unit

KRV 09 H - 5 R1 M A

Design Series Code  
A: 1<sup>st</sup> Designed

B: 2<sup>nd</sup> Designed

M: Modular Outdoor Unit

Non-Modular One Omitted

Refrigerant Type:  
R1: R410a .

R22 Omitted

Power Supply:  
2: 208-230V~, 1Ph, 60Hz  
5: 380-415V~, 3Ph, 50Hz  
9: 208-230V~, 3Ph, 60Hz  
D: 220-240V~, 3Ph, 50Hz/60Hz

4: 220-240V~, 1Ph, 50Hz  
6: 380-415V~, 3Ph, 60Hz  
G: 380-415V~, 3Ph, 50Hz/60Hz

H: Cooling & Heating

C: Cooling Only

Cooling Capacity (k Btu/h)

AUKIA Refrigerant Variable AC

# KRV 5X Series

## -Full DC Inverter KRV System



# Modular VRF-KRV 5X



## High Efficient And Energy Saving

### The Industry's Leading IPLV Value

KRV 5X achieves the industry's top class energy efficiency of cooling and heating by utilizing the advanced 180° sine wave DC Inverter driving technology, patent energy-saving operation technology and improved performance of heat exchange.

Because the outdoor ambient temperature and indoor unit load keep changing with the time of a day. Most of time, the system works under part load. So it is better to assess the energy saving performance with IPLV.  $IPLV(C) = 0.5EER(100\%) + 0.3EER(75\%) + 0.4EER(50\%) + 0.25EER(25\%)$

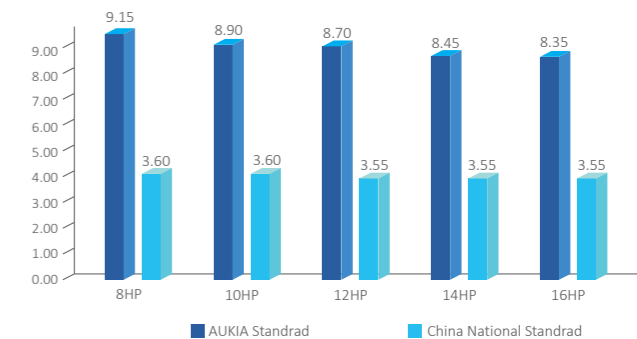

### Excellent In EER&COP

KRV 5X Series achieves the industry's top class energy efficiency in cooling and heating by utilizing all DC inverter compressors, and high efficiency heat exchanger. The cooling EER is up to 4.67 and the heating COP is up to 4.79 in the 8HP category.

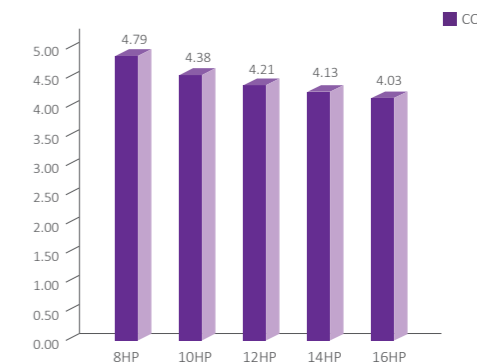
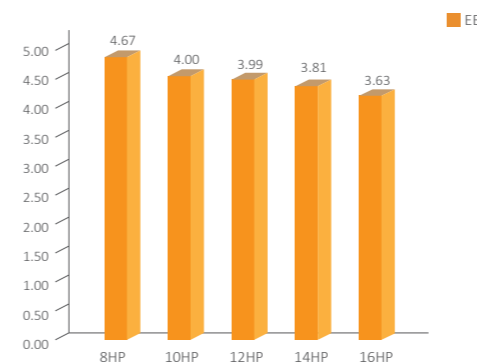

## High Efficiency DC Inverter Compressor

The built-in pump can lift condensing water up to 1200mm high from the drainage pan.

### 1. Direct suction

Small suction overheating, high efficiency.

### 2. HP chamber structure

The back wall shell and a large number of air cushion volume, reduce exhaust air flow noise.

### 3. With throwing oil tubing for compressor

When the compressor oil level higher than the warning line, system through tubing eliminate redundant frozen oil, keep the oil balance between compressor.

### 4. Exclusive high-precision asymmetric vortex disk

Using asymmetric type vortex disk structure, compared with the symmetric structure, can reduce the compressor loss, improve the efficiency of suction.

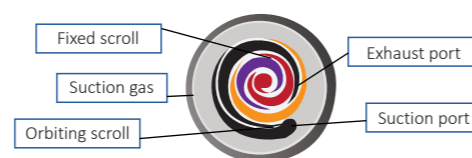

### 5. Concentrated winding

Magnetic efficiency is 12% higher than distributed winding.

### 6. Magnetic resistance DC motor

Use powerful rubidium magnet, inhibit rotary vibration, reduce the loss of magnetic field, and the efficiency increased by 25%.

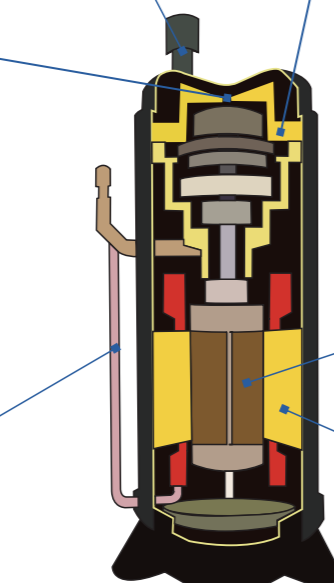

High-efficient permanent magnetic motors are installed, giving better performance than traditional DC inverter compressors.



Centralizing winding



Distributin winding

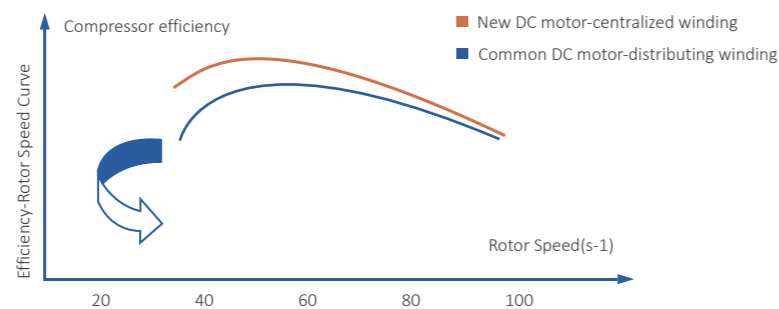

Powerful magnets provide high torque and efficiency and achieve 70% reduction in volume.

## 180° Sine Wave Control

DC inverter compressor uses 180° sine wave vector control technique, make motor operate smoothly and increases efficiency significantly compared with traditional sawtooth wave. It also can lower the noise level.

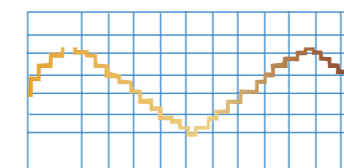

Traditional Control

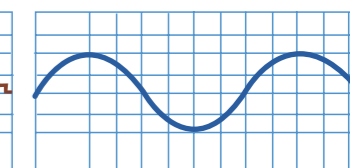

180° Sine Wave DC Control

## DC Brushless Fan Motor

DC brushless motor adjusts the fan speed by the system pressure, and running load to enhance the efficiency by 45%. The super aero fan provides a larger air volume and higher static pressure.

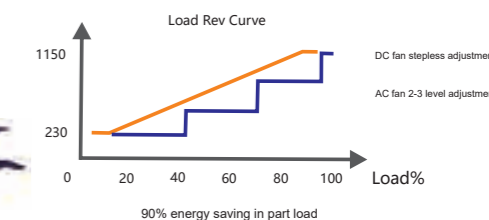

90% energy saving in part load

## High-Efficient Inverter Control Technology

The unit have the higher capacity in partial load according to controlling the operation number of the compressor and adjusting the EXV opening of the condenser side, making the compressor always maintain the highest efficiency running state.

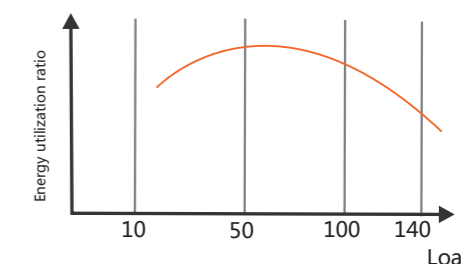
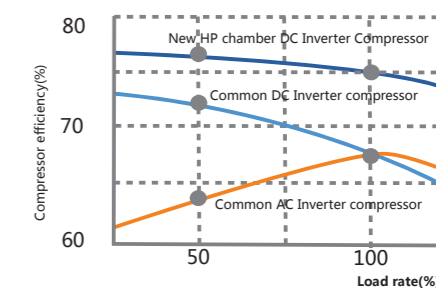
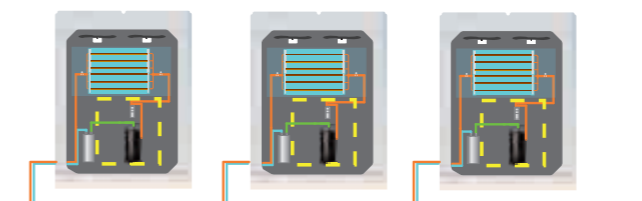

## Optimized Fan Grille

Optimized fan blade shape with new air outlet grille improves air flow volume which greatly improves fan performance and decreases noise.



## New Profile Fan Blade

The built-in pump can lift condensing water up to 1200mm high from the drainage pan.



Optimized fan



Conventional fan



## High Efficient Heat Exchanger

Optimized 2 to 1 refrigerant circuit design increases the heat exchanging efficiency and enhances the ratio of liquid which flow to the evaporator.

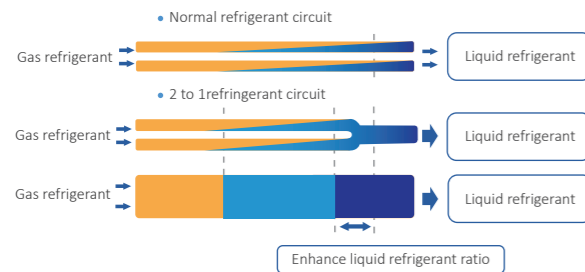

Optimized fin design, reduces the water resistance and wind resistance.

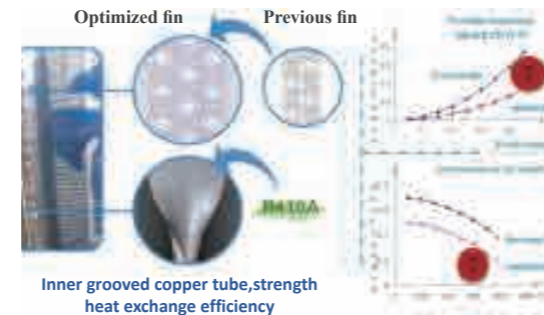

## Sub-Cooling Technology For 3 Level

Optimize the design of the condenser  
11.2°C sub-cooling by optimized refrigerant circuit and "Inverse fin type" window fin design.

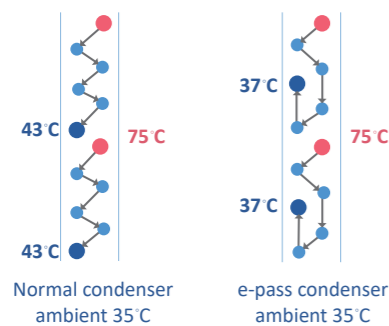

"Inverse fin type" window fin design

4.5°C sub-cooling by special plate heat exchanger further reduce the refrigerant temperature flowing into the indoor unit.

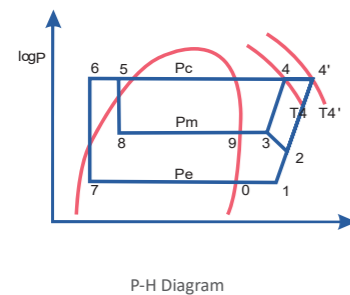

P-H Diagram

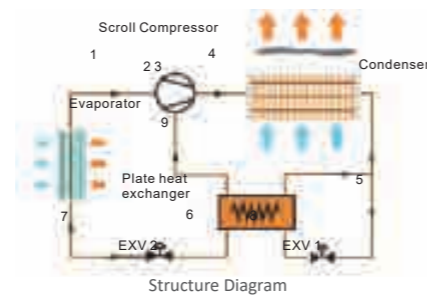

1.1°C sub-cooling by dual EXV with a special effective plate heat exchanger.



## Wide Application Range

### Wide Operation Range

The unit could operate perfectly between 52°C in hot summer and -20°C in cold winter making you feel like spring all year around, advanced system design and strict system matching and test. (cooling in -15°C )



### Wide Voltage Design

In country with unstable voltage, KRV can also run stable.

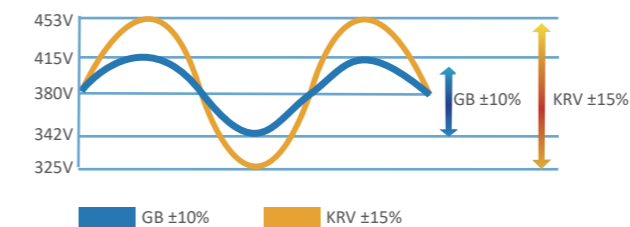

### Changeable ESP

Optimized fan provide outdoor unit up to 82Pa static pressure. Outdoor units can be installed in the service floor or facility room.



### Long Piping Length

Because of using DC inverter control technology and sub-cooling circuit technology, it is possible to design a system with longer piping and elevation difference which make it easier to design and installation.

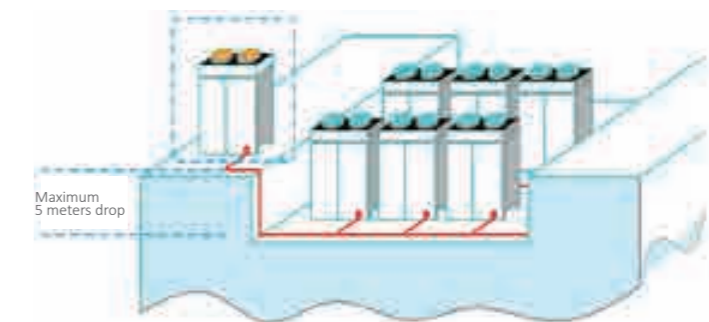
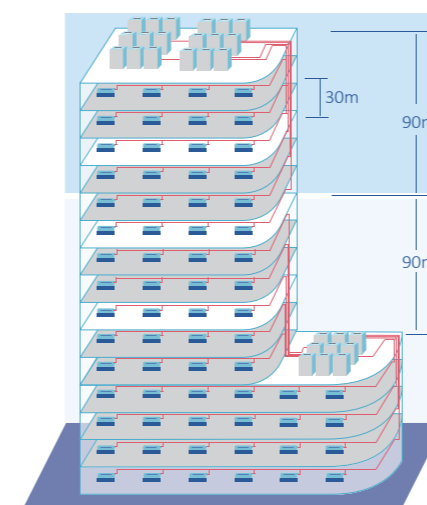

- Max. Total piping length — 1000m
- Max. Actual piping length — 200m
- Max. Level difference between indoor units — 30m
- Max. Level difference between ODU and IDU units — 90m
- Max. Level difference in the same system between ODU and ODU units — 5m
- Max. piping length from 1st indoor Branch to the farthest indoor unit — 90m

# Comfortable And Healthy Environment

## Silence Operation

### Outdoor Unit Quiet Mode

By using optimized fan blades and the CFD (computational Fluid Dynamics) technology, the product is equipped with the night low-noise operation function. Provide more quiet operation during the night. Minimum operation noise only 45dB(A)

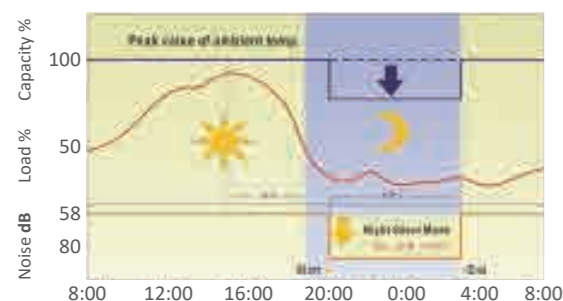

### Indoor Unit Quiet Mode

Innovative centrifugal fan for large diameter and a new design of the spiral duct system equipped with high-quality motor at the same time, making the air supply more quietly and smoothly. The lowest noise is 20 db(A).

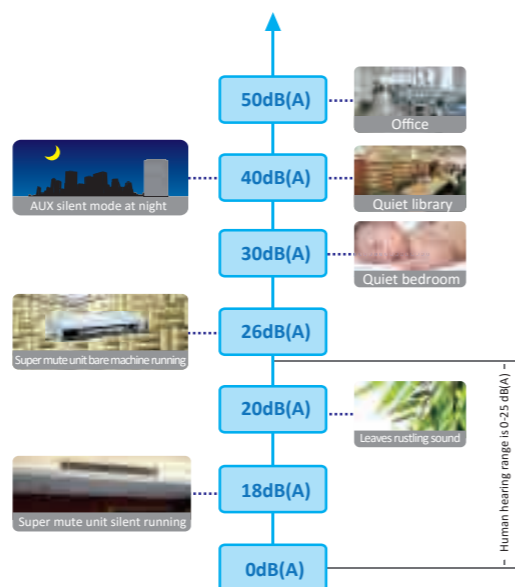

## Intelligent Defrosting

AUKIA intelligent defrosting technique extends the heating operation and decrease the frequency of defrosting. Result in stable room temperature, offer comfort life.

Base on the main unit and at the end of the EXV control the output, fast bolt in liquid refrigerant system, unit operation is more stable; Through the dry run, defrosting exhaust temperature higher, more complete, more conventional. The defrosting time less 3 min than others at least

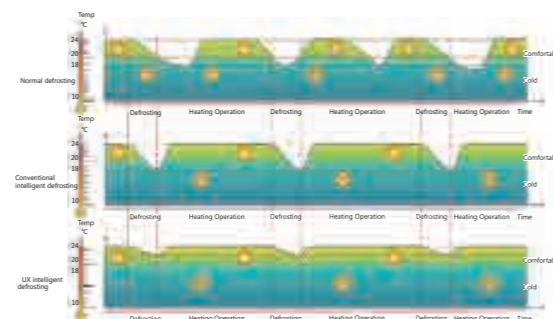

## Fast Warm Up And Cool Down Technology

The DC Inverter Compressor system reaches full load rapidly providing less temperature fluctuation and an improved living environment, bring great user experience.

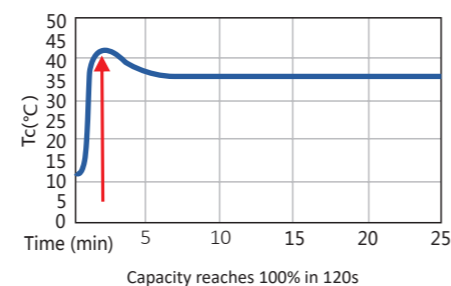

## Precise Temperature Control

Double EXVs Control  
Double EXVs in one system, each EXV part achieves 480 Plus rate to precisely adjust refrigerant flow.



AUKIA composite temperature control technology, through the indoor/outdoor operation condition detection, adjust outdoor power output, optimize the indoor air distribution, achieve the high precision adjustment of 0.5 °C .

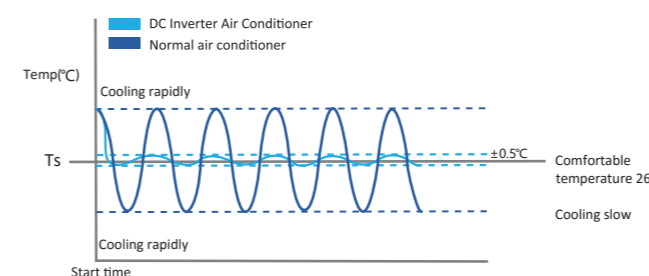

The unit uses PI calculation principle to calculate the percentage of indoor capacity demand according to indoor temperature fluctuations, to perform real-time control to the compressor operating frequency and through the double EXV adjustment, precision up to level 1000, accurately control the refrigerant flow, assure indoor comfort.

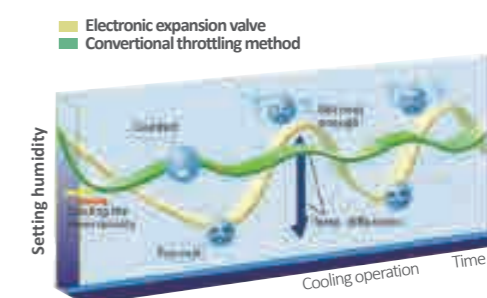

## Humanization Design

### VIP Function

Special VIP control function, the VIP room will decide the whole system operation mode, prior to other mode or economic locking function, ensure the priority of the important room.

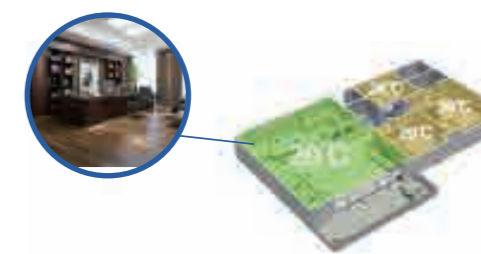

### Auto Restart Function

The AC can automatically memorize the operation setting when power is cut off accidentally. It can return to previous setting when power resumes. Recover the former operation state when power is restored, no need restart the unit manually

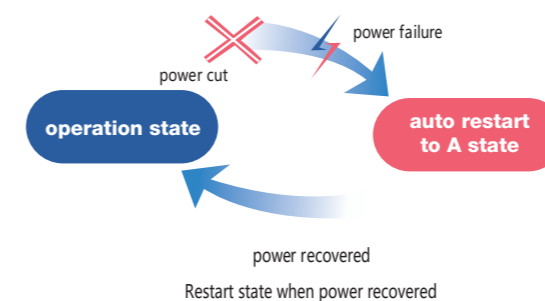

### Economic Locking Function

Special design economic locking function, through outdoor PCB switch setting. If work in economic lock, AC lowest work cooling temperature will keep in 26°C and highest heating temperature keep 20°C.



## Easy Installation & Maintenance

### No Oil Balance Pipe Between ODUS

High efficient oil/gas separating tech, make the system oil balance between compressors without oil balance pipe.

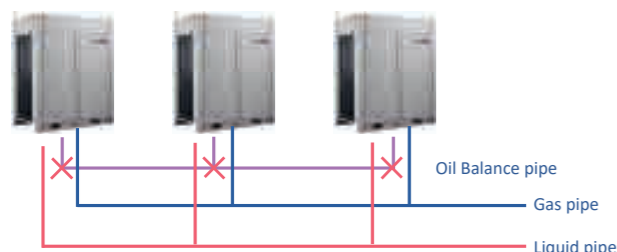

### Non-Polar Communication

No polar in communication wire, easy installation and commissioning.



### Auto Addressing

The outdoor units distribute indoor system address automatically. No need manually setting. More convenient and saving the installation time.



### Auto Refrigerant Charging

The system according to all kinds of sensor acquisition system parameters, automatically calculate the amount of refrigerant, filling automatically.



### Easy Maintenance

The PCB could record 30 minutes running information before the error occur. Self-diagnosis function helps service engineer locate faults quickly and easily. It's convenient for the trouble shooting.

## Reliable & Stable

### Module Alternate Operation

In one combination system, any module could run as the master unit according to the running time. Balance the life of the outdoor units in one system.



### Back-Up Operation Technology

#### Module Back-Up Technology

As one of module breaks down, the rest of modules in the same refrigerant system start-up urgently.

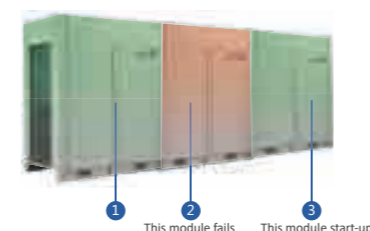

#### Fan Motor Back-Up Technology

As one of fan motor breaks down, the rest of fan in the outdoor unit start-up, ensure the outdoor unit is normal operation.



### Auto Addressing

The outdoor units distribute indoor system address automatically. No need manually setting. More convenient and saving the installation time.



### Auto Refrigerant Charging

The system according to all kinds of sensor acquisition system parameters, automatically calculate the amount of refrigerant, filling automatically.



### All-Around Protection

All-around protection to ensure long-term life of the unit.



### Refrigerant Cooling

Using cold media to filter plate heat exchanger, keep the machine filter plate temperature at a relatively low temperature operation, unit operation more reliable.



### Oil Return Control Technology

#### Dynamic Oil Return Control Technology

Monitor compressor running state and running time, computing system reasonable oil return time.

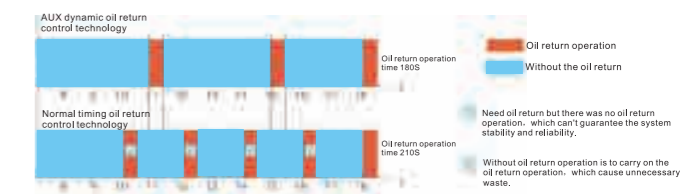

#### 6-Step Oil Separating Technology

Completely solve the problem of oil, the system more stable and reliable

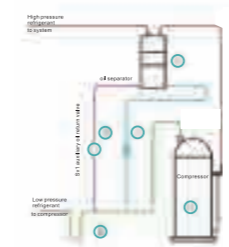

1. Compressor with oil mist separator
2. Oil self balancing control design
3. High efficient oil separator
4. Capillary static oil return control
5. SV1 auxiliary oil return control
6. System with oil return design

#### Compressor Throwing Oil Technology

When the compressor oil level higher than the warning line, system through tubing eliminate redundant frozen oil, keep the oil balance between compressor.





# KRV 5X

Flexible Outdoor Unit Combination						
kW	HP	8HP	10HP	12HP	14HP	16HP
25.2	8	★				
28.0	10		★			
33.5	12			★		
40.0	14				★	
45.0	16					★
53.2	18	★	★			
56.0	20		★★			
61.5	22		★	★		
67.0	24			★★		
73.0	26		★			★
78.5	28			★		★
85.0	30				★	★
90.0	32					★★
95.0	34		★	★★		
100.5	36			★★★		
106.5	38		★	★		★
112.0	40			★★		★
118.5	42			★	★	★
123.5	44				★★	★
130.0	46				★	★★
135.0	48					★★★
140.0	50		★	★★		★
145.5	52			★★★		★
151.5	54		★	★		★★
157.0	56			★★		★★
163.0	58		★			★★★
168.5	60			★		★★★
175.0	62				★	★★★
180.0	64					★★★★

## KRV 5X Series 380~415V-50(60)Hz/220V-60Hz

HP	8		10		12		14		16	
Model	Outdoor	380~415V	KRV86H-GR1MA	KRV96H-GR1MA	KRV114H-GR1MA	KRV136H-GR1MA	KRV154H-GR1MA			
		220V	KRV86H-DR1MA	KRV96H-DR1MA	KRV114H-DR1MA	KRV136H-DR1MA	KRV154H-DR1MA			
Combination		HP	8	10	12	14	16			
Capacity	Cooling	kW	25.2	28	33.5	40	45			
		kBtu/h	86.0	95.5	114.3	136.5	153.5			
Capacity	Heating	kW	28.0	31.5	37.5	45	50			
		kBtu/h	95.5	107.5	128	153.5	170.6			
Electric Data	Power Supply	V-,Hz,Ph	380~415,50(60),3&220,60,3	380~415,50(60),3&220,60,3	380~415,50(60),3&220,60,3	380~415,50(60),3&220,60,3	380~415,50(60),3&220,60,3			
	Cooling Power Input	kW	5.40	7.00	8.40	10.50	12.40			
	Heating Power Input	kW	5.85	7.20	8.90	10.90	12.40			
	Cooling Current	A	8.60	10.80	13.50	18.20	20.30			
	Heating Current	A	8.75	10.95	13.80	16.50	19.00			
	EER		4.67	4.00	3.99	3.81	3.63			
Performance	Air Flow Volume	m³/h	12000	12000	12000	7250 × 2	7500 × 2			
	Noise Level	dB(A)	45~58	45~58	45~58	47~61	47~61			
Compressor	Type		DC Inverter	DC Inverter	DC Inverter	DC Inverter	DC Inverter			
	Quantity		1	1	1	1	1			
Fan Motor	Type		DC motor	DC motor	DC motor	DC motor	DC motor			
	Quantity		1	1	1	2	2			
Max. No. of Indoor Units	unit		13	16	19	23	26			
Connection Ratio	%		50~130	50~130	50~130	50~130	50~130			
Dimension(WxDxH)	Net	mm	935 × 765 × 1600	935 × 765 × 1600	935 × 765 × 1600	1340 × 765 × 1600	1340 × 765 × 1600			
	Packing	mm	980 × 810 × 1850	980 × 810 × 1850	980 × 810 × 1850	1400 × 810 × 1850	1400 × 810 × 1850			
Weight	Net	kg	223	223	248	298	298			
	Gross	kg	243	243	268	320	320			
Refrigerant Type			R410a	R410a	R410a	R410a	R410a			
Pipe Diameter	Liquid Side	mm(inch)	12.7(1/2)	12.7(1/2)	12.7(1/2)	12.7(1/2)	12.7(1/2)			
	Gas Side	mm(inch)	22.2(7/8)	22.2(7/8)	22.2(7/8)	28.6(9/8)	28.6(9/8)			
Operation Range	Cooling	°C	-15~52	-15~52	-15~52	-15~52	-15~52			
	Heating	°C	-20~29	-20~29	-20~29	-20~29	-20~29			
Stuffing Quantity	20/40/40H	unit	14/28/28	14/28/28	14/28/28	11/22/22	11/22/22			

## KRV 5X Series 380~415V-50(60)Hz/220V-60Hz

HP	18		20		22		24		26	
Model	Outdoor	380~415V	KRV181H-GR1MA	KRV191H-GR1MA	KRV210H-GR1MA	KRV229H-GR1MA	KRV249H-GR1MA			
		220V	KRV181H-DR1MA	KRV191H-DR1MA	KRV210H-DR1MA	KRV229H-DR1MA	KRV249H-DR1MA			
Combination		HP	8+10	10 × 2	10+12	12 × 2	10+16			
Capacity	Cooling	kW	53.2	56	61.5	67	73			
		kBtu/h	181.5	191	209.8	228.6	249			
Capacity	Heating	kW	59.5	63	69	75	81.5			
		kBtu/h	203	215	235.5	256	278.1			
Electric Data	Power Supply	V-,Hz,Ph	380~415,50(60),3&220,60,3	380~415,50(60),3&220,60,3	380~415,50(60),3&220,60,3	380~415,50(60),3&220,60,3	380~415,50(60),3&220,60,3			
	Cooling Power Input	kW	12.4	14	15.4	16.8	19.4			
	Heating Power Input	kW	13.05	14.4	16.1	17.8	19.6			
	Cooling Current	A	19.4	21.6	24.3	24	31.1			
	Heating Current	A	19.7	21.9	24.75	27.6	29.95			
	EER		4.29	4.00	3.99	3.99	3.76			
Performance	Air Flow Volume	m³/h	12000 × 2	12000 × 2	12000 × 2	12000 × 2	12000 × 2			
	Noise Level	dB(A)	47~61	47~61	47~61	47~62	47~62			
Compressor	Type		DC Inverter	DC Inverter	DC Inverter	DC Inverter	DC Inverter			
	Quantity		2	2	2	2	2			
Fan Motor	Type		DC motor	DC motor	DC motor	DC motor	DC motor			
	Quantity		2	2	2	2	3			
Max. No. of Indoor Units	unit		31	33	36	39	43			
Connection Ratio	%		50~130	50~130	50~130	50~130	50~130			
Dimension(WxDxH)	Net	mm	(935 × 765 × 1600) × 2	(935 × 765 × 1600) × 2	(935 × 765 × 1600) × 2	(935 × 765 × 1600) × 2	(935 × 765 × 1600) × 2			
	Packing	mm	(980 × 810 × 1850) × 2	(980 × 810 × 1850) × 2	(980 × 810 × 1850) × 2	(980 × 810 × 1850) × 2	(980 × 810 × 1850) × 2			
Weight	Net	kg	223 × 2	223 × 2	223+248	248 × 2	223+298			
	Gross	kg	243 × 2	243 × 2	243+268	268 × 2	243+320			
Refrigerant Type			R410a	R410a	R410a	R410a	R410a			
Pipe Diameter	Liquid Side	mm(inch)	12.7(1/2)	15.88(5/8)	15.88(5/8)	15.88(5/8)	19.05(3/4)			
	Gas Side	mm(inch)	28.6(9/8)	28.6(9/8)	28.6(9/8)	28.6(9/8)	34.93(1 1/8)			
Operation Range	Cooling	°C	-15~52	-15~52	-15~52	-15~52	-15~52			
	Heating	°C	-20~29	-20~29	-20~29	-20~29	-20~29			

Notes:

- Cooling Capacity: Indoor temperature 27°C DB/19°C WB; Outdoor temperature: 35°C DB/24°C WB.
- Heating Capacity: Indoor temperature 20°C DB; Outdoor temperature: 7°C DB/6°C WB.
- Piping Length: Equivalent piping length: 7.5m, level difference: 0m.
- Anechoic chamber conversion value, measured in test room. During actual operation, these values are normally somewhat higher as a result of ambient conditions.
- The above designs and specifications are subject to change without prior notice. Final specifications please refer to technical specification provided by sales representative.



# Modular VRF-KRV 4



## High Efficient And Energy Saving

### The Industry's Leading IPLV Value

KRV 5X achieves the industry's top class energy efficiency of cooling and heating by utilizing the advanced 180° sine wave DC Inverter driving technology, patent energy-saving operation technology and improved performance of heat exchange.

Because the outdoor ambient temperature and indoor unit load is different at different times of day, most of time, the system works under part load. So it is better to assess the energy saving performance using IPLV.  $IPLV(C) = 0.5EER(100\%) + 0.3EER(75\%) + 0.4EER(50\%) + 0.25EER(25\%)$

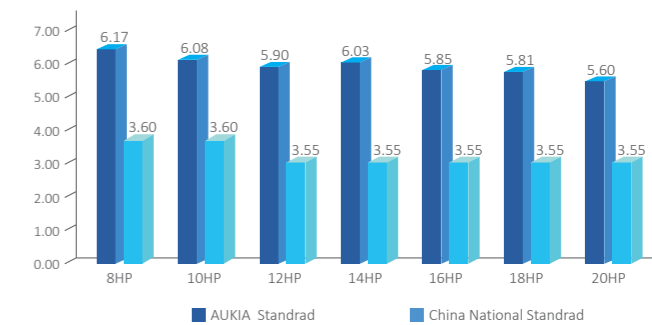

### Excellent In EER&COP

KRV 5X Series achieves the industry's top class energy efficiency in cooling and heating by utilizing all DC inverter compressors, and high efficiency heat exchanger.

The cooling EER is up to 4.43 and the heating COP is up to 4.56 in the 8HP category.

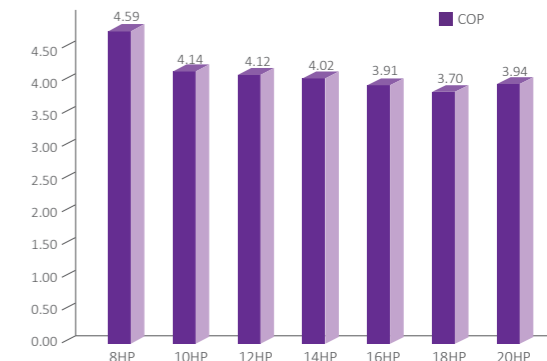
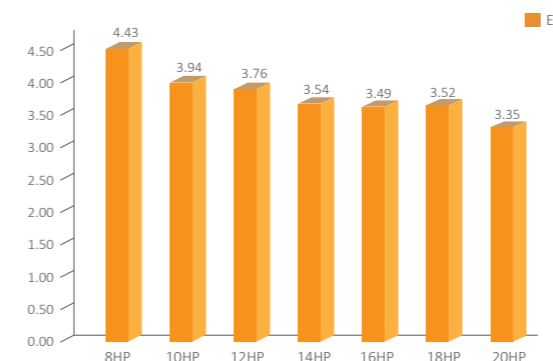

**KRV 4 Series**



## High Efficiency DC Inverter Compressor

The built-in pump can lift condensing water up to 1200mm high from the drainage pan.

### 1. Direct suction

Small suction overheating, high efficiency.

### 2. HP chamber structure

The back wall shell and a large number of air cushion volume, reduce exhaust air flow noise.

### 3. With throwing oil tubing for compressor

When the compressor oil level higher than the warning line, system through tubing eliminate redundant frozen oil, keep the oil balance between compressor.

### 4. Exclusive high-precision asymmetric vortex disk

Using asymmetric type vortex disk structure, compared with the symmetric structure, can reduce the compressor loss, improve the efficiency of suction.

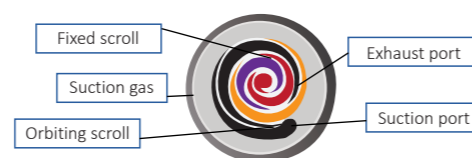

### 5. Concentrated winding

Magnetic efficiency is 12% higher than distributed winding.

### 6. Magnetic resistance DC motor

Use powerful rubidium magnet, inhibit rotary vibration, reduce the loss of magnetic field, and the efficiency increased by 25%.

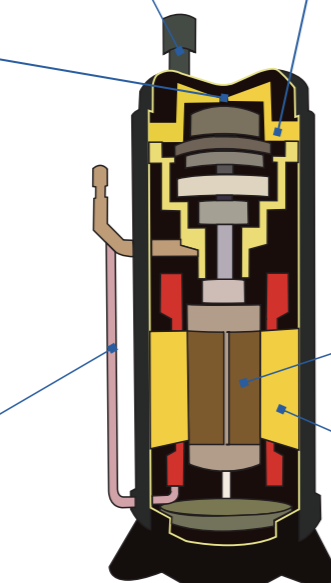

High-efficient permanent magnetic motors are installed, giving better performance than traditional DC inverter compressors.



Centralizing winding



Distributin winding

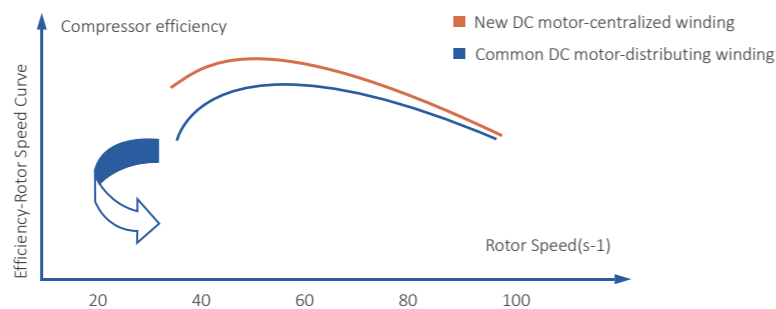

Powerful magnets provide high torque and efficiency and achieve 70% reduction in volume.

## 180° Sine Wave Control

DC inverter compressor users 180° sine wave vector control technique makes motor operate smooth and increases the efficiency. significantly compared with traditional sawtooth wave. It also can lower the noise level.

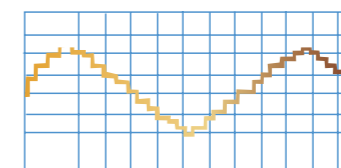

Traditional Control

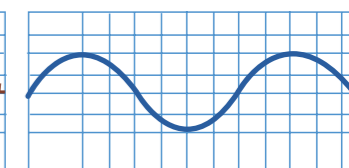

180° Sine Wave DC Control

## DC Brushless Fan Motor

DC brushless motor adjusts the fan speed by the system pressure, and running load to enhance the efficiency by 45%. The super aero fan provides a larger air volume and higher static pressure.

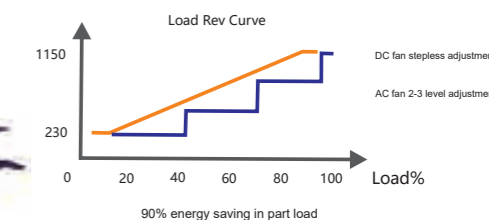

90% energy saving in part load

## High-Efficient Inverter Control Technology

The unit have the higher capacity in partial load according to controlling the operation number of the compressor and adjusting the EXV opening of the condenser side, making the compressor always maintain the highest efficiency running state.

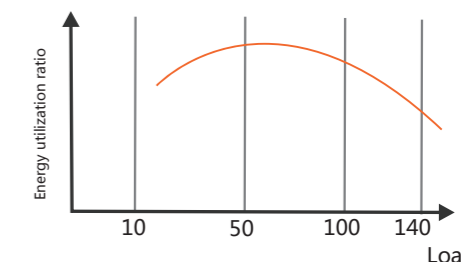
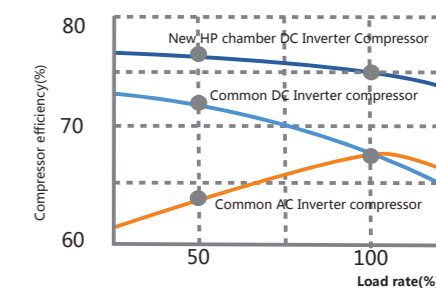

## Optimized Fan Grille

Optimized fan blade shape with new air outlet grille enhances air flow volume which greatly improves fan performance and decreases noise.



## New Profile Fan Blade

The built-in pump can lift condensing water up to 1200mm high from the drainage pan.



Optimized fan

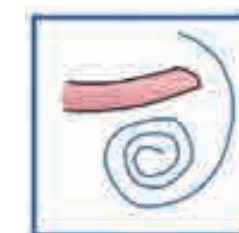

Conventional fan

## High Efficient Heat Exchanger

Optimized 2 to 1 refrigerant circuit design, increase the heat exchanging efficiency and enhance the ratio of liquid which flow to the evaporator.

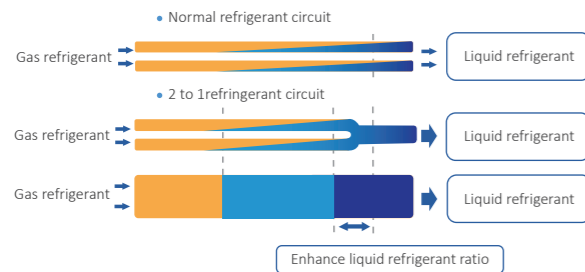

Optimized fin design, reduces the water resistance and wind resistance.

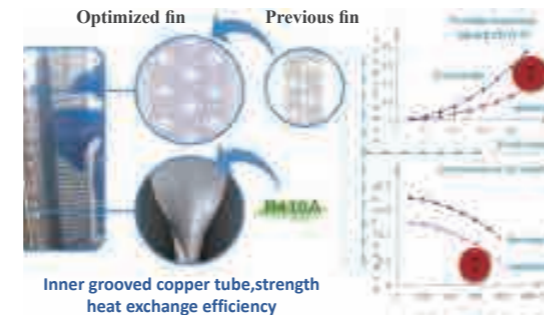

## Sub-Cooling Technology For 3 Level

Optimize the design of the condenser  
 11.2°C sub-cooling by optimized refrigerant circuit and "Inverse fin type" window fin design.

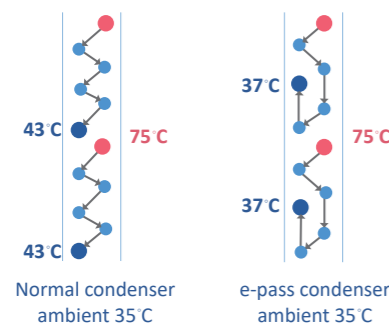

"Inverse fin type" window fin design

4.5°C sub-cooling by special plate heat exchanger further reduce the refrigerant temperature flowing into the indoor unit.

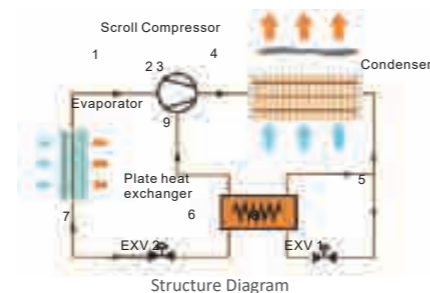
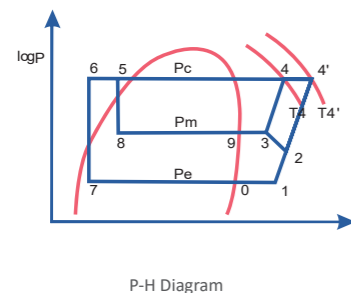

1.1°C sub-cooling by dual EXV with a special and effective plate heat exchanger.

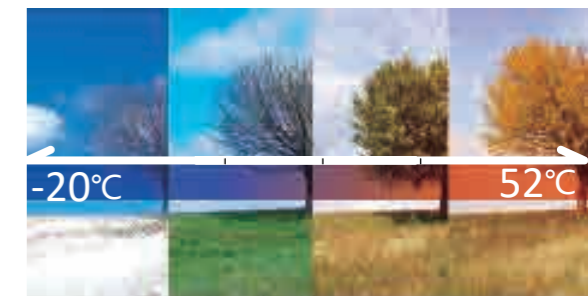

Plate heat exchanger Dual EXV

## Wide Application Range

### Wide Operation Range

The unit could operate perfectly between 52°C in hot summer and -20°C in cold winter making you feel like spring all year around, advanced system design and strict system matching and test. (cooling in -15°C )



### Wide Voltage Design

In country with unstable voltage, KRV can also run stably.

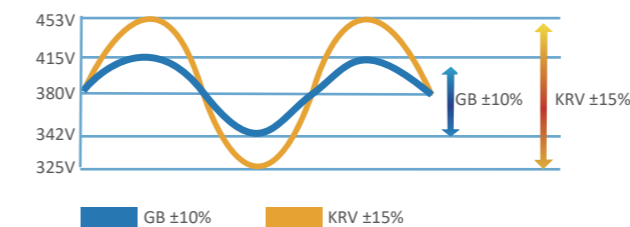

### Changeable ESP

Optimized fan provide outdoor unit up to 82Pa static pressure. Outdoor units can be installed in the service floor or facility room.



### Long Piping Length

Thanks to the DC inverter control technology and sub-cooling circuit technology ,it is possible to design a system with longer piping and elevation difference which make it easier to design and installation.

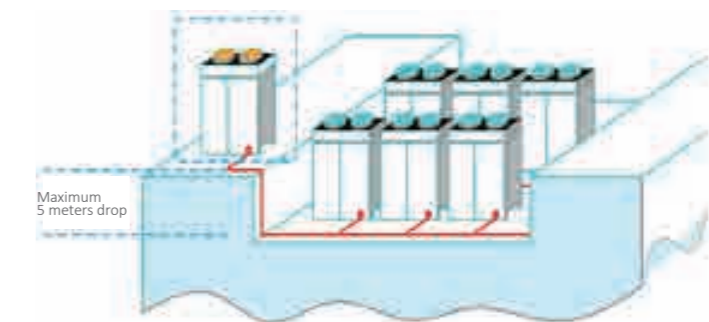
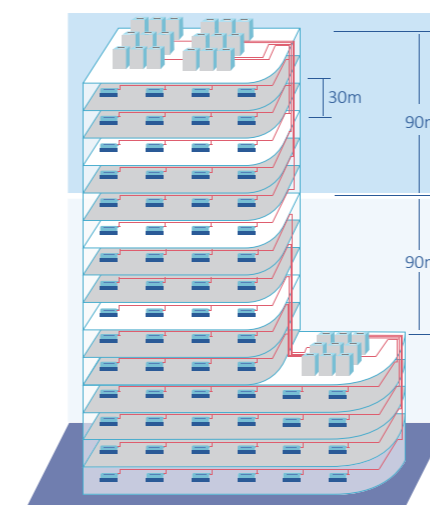

- Max. Total piping length — 1000m
- Max. Actual piping length —175m
- Max. Level difference between indoor units — 30m
- Max. Level difference between ODU and IDU units —90m
- Max. Level difference in the same system between ODU and ODU units —5m
- Max. piping length from 1st indoor Branch to the farthest indoor unit —90m



# Comfortable And Healthy Environment

## Silence Operation

### Outdoor Unit Quiet Mode

By using optimized fan blades and the CFD (computational Fluid Dynamics) technology, the product is equipped with the night low-noise operation function. Provide more quiet operation during the night. Minimum operation noise only 45dB(A)

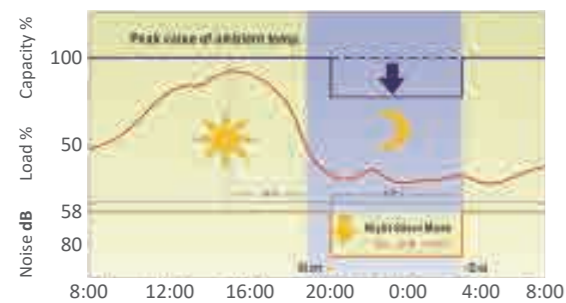

### Indoor Unit Quiet Mode

Innovative centrifugal fan for large diameter and a new design of the spiral duct system equipped with high-quality motor at the same time, making the air supply more quietly and smoothly. The lowest noise is 20 db(A).

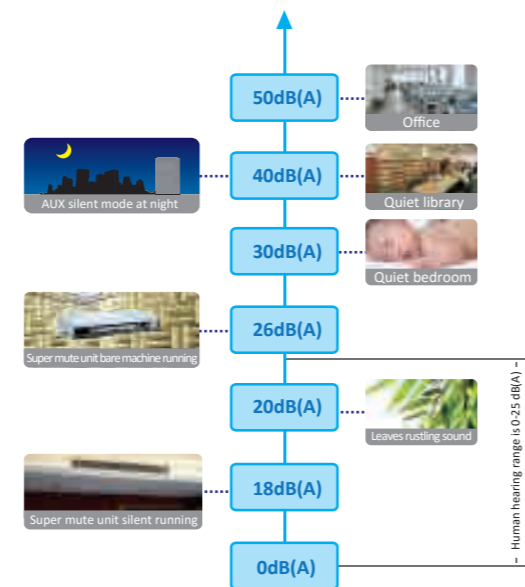

## Intelligent Defrosting

AUKIA intelligent defrosting technique extends the heating operation and decrease the frequency of defrosting. Result in stable room temperature, offer comfort life.

Base on the main unit and at the end of the EXV control the output, fast bolt in liquid refrigerant system, unit operation is more stable; Through the dry run, defrosting exhaust temperature higher, more complete, more conventional. The defrosting time less 3 min than others at least

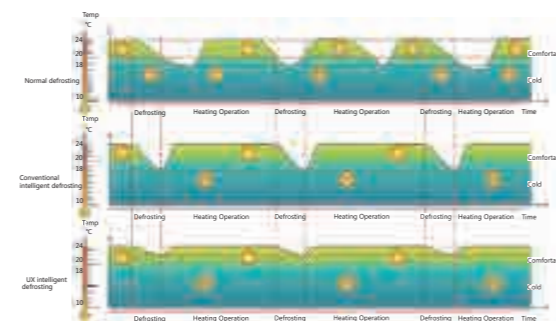

## Fast Warm Up and Cool Down Technology

The DC Inverter Compressor system reaches full load rapidly providing less temperature fluctuation and an improved living environment, bring great user experience.

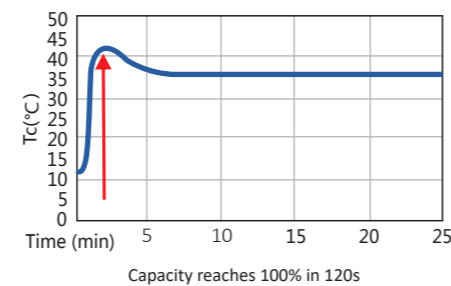

## Precise Temperature Control

### Double EXVs Control

Double EXVs in one system, each EXV part achieves 480 Plus rate to precisely adjust refrigerant flow.



AUKIA composite temperature control technology, through the indoor/outdoor operation condition detection, adjust outdoor power output, optimize the indoor air distribution, achieve the high precision adjustment of 0.5 °C .

The unit uses PI calculation principle to calculate the percentage of indoor capacity demand according to indoor temperature fluctuations, to perform real-time control to the compressor operating frequency and through the double EXV adjustment, precision up to level 1000, accurately control the refrigerant flow, assure indoor comfort.

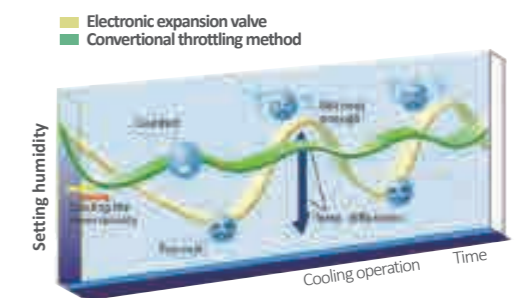
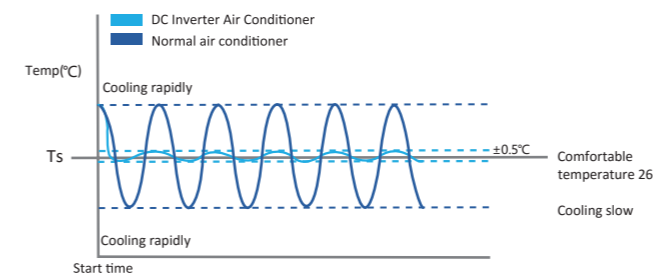

## Humanization Design

### VIP Function

Special VIP control function, the VIP room will decide the whole system operation mode, prior to other mode or economic locking function, ensure the priority of the important room.



### Auto Restart Function

The AC can automatically memorize the operation setting when power is cut off accidentally. It can return to previous setting when power resumes.

Recover the former operation state when power is restored, no need restart the unit manually

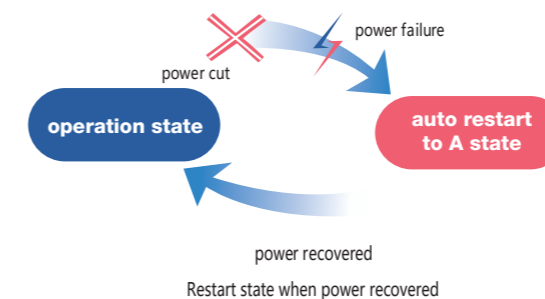

### Economic Locking Function

Special design economic locking function, through outdoor PCB switch setting. If work in economic lock, AC lowest work cooling temperature will keep in 26°C and highest heating temperature keep 20°C.



## Easy Installation & Maintenance

### No Oil Balance Pipe Between ODUS

High efficient oil/gas separating tech, make the system oil balance between compressors without oil balance pipe.

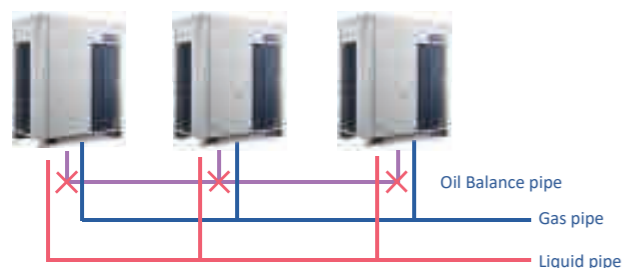

### Non-Polar Communication

No polar in communication wire, easy installation and commissioning.



### Auto Addressing

The outdoor units distribute indoor system address automatically. No need manually setting. More convenient and saving the installation time.



### Auto Refrigerant Charging

The system according to all kinds of sensor acquisition system parameters, automatically calculate the amount of refrigerant, filling automatically.

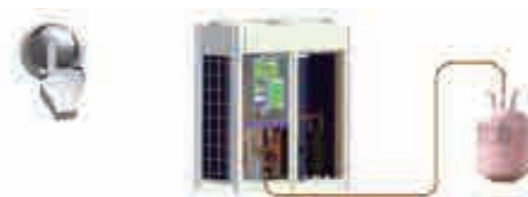

### Easy Maintenance

The PCB could record 30 minutes running information before the error occur. Self-diagnosis function helps service engineer locate faults quickly and easily. It's convenient for the trouble shooting.

## Reliable & Stable

### Module Alternate Operation

In one combination system, any module could run as the master unit according to the running time. Balance the life of the outdoor units in one system.



### Back-Up Operation Technology

#### Module Back-Up Technology

As one module breaks down, the rest of modules in the same refrigerant system start-up urgently.

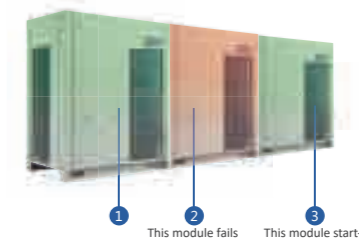

#### Compressor Back-Up Technology

As one fan motor breaks down, the rest of fan in the outdoor unit start-up, ensure the outdoor unit is normal operation.



#### Fan Motor Back-Up Technology

As one fan motor breaks down, the rest of fan in the outdoor unit start-up, ensure the outdoor unit is normal operation.



### All-Around Protection

All-around protection to ensure long-term life of the unit.



### Oil Return Control Technology

#### Dynamic Oil Return Control Technology

Monitor compressor running state and running time, computing system reasonable oil return time.



#### 6-Step Oil Separating Technology

Completely solve the problem of oil, the system more stable and reliable

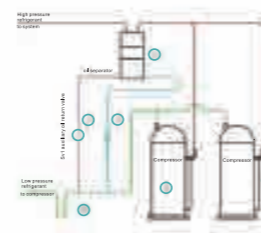

1. Compressor with oil mist separator
2. Oil self balancing control design
3. High efficient oil separator
4. Capillary static oil return control
5. SV1 auxiliary oil return control
6. System with oil return design

#### Compressor Throwing Oil Technology

When the compressor oil level higher than the warning line, system through tubing eliminate redundant frozen oil, keep the oil balance between compressor.







## KRV 4 Series 380~415V-50Hz/380~415V-60Hz

HP			66	68	70	72
Model	Outdoor	380~415V	KRV630H-5R1MA	KRV651H-5R1MA	KRV670H-5R1MA	KRV588H-5R1MA
		220V	KRV630H-9R1MA	KRV651H-9R1MA	KRV670H-9R1MA	KRV588H-9R1MA
Combination		HP	12+18×3	16×2+18×2	16+18×3	18×4
Capacity	Cooling	kW	184.7	190.8	196.2	201.6
		kBtu/h	630.3	651	669.5	688
	Heating	kW	204	211	216.5	222
		kBtu/h	696.2	720	738.8	757.6
Electric Data	Power Supply	V-,Hz,Ph	380~415,50,3,380~415,60,3	380~415,50,3,380~415,60,3	380~415,50,3,380~415,60,3	380~415,50,3,380~415,60,3
	Cooling Power Input	kW	51.8	54.4	55.8	57.2
	Heating Power Input	kW	54.1	55.6	57.8	60
	Cooling Current	A	83.4	88.8	91	93.2
	Heating Current	A	82.2	84.6	87.9	91.2
	EER		3.57	3.51	3.52	3.52
	COP		12.87	12.95	12.78	12.63
	Performance	Air Flow Volume	m <sup>3</sup> /h	12000+7500×6	7500×8	7500×8
Noise Level		dB(A)	47-65	47-65	47-65	47-65
Compressor	Type		DC Inverter+Fixed	DC Inverter+Fixed	DC Inverter+Fixed	DC Inverter+Fixed
	Quantity		4+3	4+4	4+4	4+4
Fan Motor	Type		DC motor+AC motor	DC motor+AC motor	DC motor+AC motor	DC motor+AC motor
	Quantity		7	8	8	8
Max. No. of Indoor Units	unit		64	64	64	64
Connection Ratio	%		50-130	50-130	50-130	50-130
Dimension(WxDxH)	Net	mm	(935×765×1600)+(1340×765×1600)×3	(1340×765×1600)×4	(1340×765×1600)×4	(1340×765×1600)×4
	Packing	mm	(980×810×1850)+(1400×810×1850)×3	(1400×810×1850)×4	(1400×810×1850)×4	(1400×810×1850)×4
Weight	Net	kg	248+318×3	303×2+318×2	303+318×3	318×4
	Gross	kg	268+340×3	325×2+340×2	325+340×3	340×4
Refrigerant Type			R410a	R410a	R410a	R410a
Pipe Diameter	Liquid Side	mm(inch)	22.2(7/8)	22.2(7/8)	22.2(7/8)	22.2(7/8)
	Gas Side	mm(inch)	47.6(15/8)	47.6(15/8)	47.6(15/8)	47.6(15/8)
Operation Range	Cooling	°C	-15-52	-15-52	-15-52	-15-52
	Heating	°C	-20-29	-20-29	-20-29	-20-29

## KRV 4 Series 380~415V-50Hz/380~415V-60Hz

HP			74	76	78	80
Model	Outdoor	380~415V	KRV707H-5R1MA	KRV726H-5R1MA	KRV745H-5R1MA	KRV764H-5R1MA
		220V	KRV707H-9R1MA	KRV726H-9R1MA	KRV745H-9R1MA	KRV764H-9R1MA
Combination		HP	18×3+20	18×2+20×2	18+20×3	20×4
Capacity	Cooling	kW	207.2	212.8	218.4	224
		kBtu/h	707.1	726.2	745.3	764.4
	Heating	kW	229.5	237	244.5	252
		kBtu/h	783.2	808.8	834.4	860
Electric Data	Power Supply	V-,Hz,Ph	380~415,50,3,380~415,60,3	380~415,50,3,380~415,60,3	380~415,50,3,380~415,60,3	380~415,50,3,380~415,60,3
	Cooling Power Input	kW	59.6	62	64.4	66.8
	Heating Power Input	kW	61	62	63	64
	Cooling Current	A	97	100.8	104.6	108.4
	Heating Current	A	93.8	96.4	99	101.6
	EER		3.48	3.43	3.39	3.35
	COP		12.84	13.05	13.24	13.44
	Performance	Air Flow Volume	m <sup>3</sup> /h	7500×8	7500×8	7500×8
Noise Level		dB(A)	47-65	47-65	47-65	47-65
Compressor	Type		DC Inverter+Fixed	DC Inverter+Fixed	DC Inverter+Fixed	DC Inverter+Fixed
	Quantity		4+4	4+4	4+4	4+4
Fan Motor	Type		DC motor+AC motor	DC motor+AC motor	DC motor+AC motor	DC motor+AC motor
	Quantity		8	8	8	8
Max. No. of Indoor Units	unit		64	64	64	64
Connection Ratio	%		50-130	50-130	50-130	50-130
Dimension(WxDxH)	Net	mm	(1340×765×1600)×4	(1340×765×1600)×4	(1340×765×1600)×4	(1340×765×1600)×4
	Packing	mm	(1400×810×1850)×4	(1400×810×1850)×4	(1400×810×1850)×4	(1400×810×1850)×4
Weight	Net	kg	318×3+355	318×2+355×2	318+355×3	355×4
	Gross	kg	340×3+371	340×2+371×2	340+371×3	371×4
Refrigerant Type			R410a	R410a	R410a	R410a
Pipe Diameter	Liquid Side	mm(inch)	22.2(7/8)	22.2(7/8)	22.2(7/8)	22.2(7/8)
	Gas Side	mm(inch)	47.6(15/8)	47.6(15/8)	47.6(15/8)	47.6(15/8)
Operation Range	Cooling	°C	-15-52	-15-52	-15-52	-15-52
	Heating	°C	-20-29	-20-29	-20-29	-20-29

Notes:

- 1.Cooling Capacity: Indoor temperature 27°C DB/19°C WB; Outdoor temperature: 35°C DB/24°C WB.
- 2.Heating Capacity: Indoor temperature 20°C DB; Outdoor temperature: 7°C DB/6°C WB.
- 3.Piping Length: Equivalent piping length: 7.5m, level difference: 0m.
- 4.Anechoic chamber conversion value, measured in test room. During actual operation. These values are normally somewhat higher as a result of ambient conditions.
- 5.The above designs and specifications are subject to change without prior notice. Final specifications please refer to technical specification provided by sales representative.



**KRV Mini Series**

# Mini VRF-KRV Mini



## 180° Sine Wave Control

180 degree sine wave DC inverter technology, DC inverter output smooth sine wave, of compressor speed and system output capability of precise control, according to the actual load linear output, improve the operation efficiency of the motor. ensure the high efficiency under low load.

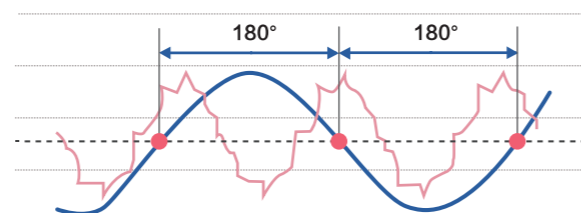

## Long Piping Technology

The maximum single piping length of 3HP unit is up to 25m, and the height can reach 15 meters; the 5HP and 6HP units single piping length can be 50 meters, and the height can be up to 30m.

## Wide Operation Range

The unit could operate perfectly between 52°C in hot summer and -20°C in cold winter making you feel like spring all year around with advanced system design and strict matching test(cooling in -10°C ).

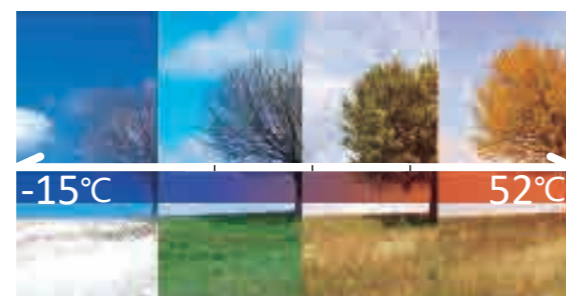

## DC Inverter Compressor

Made of rare earth permanent magnetic material, the rotor could change the motor's round speed by changing the DC voltage motor, thus overcome the electromagnetic noise and rotor loss of AC inverter compressor, then achieves high efficiency as well as low noise.

## Auto Restart Function

The AC can automatically memorize the operation setting when power is cut off accidentally. It can return to previous setting when power resumes. Recover the former operation state when power is restored , no need restart the unit manually

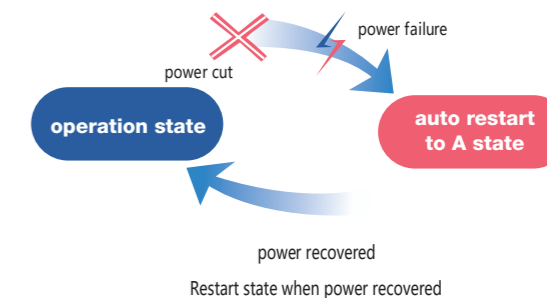

## Fast Cooling/Heating Technology

The DC Inverter Compressor system reaches full load rapidly providing less temperature fluctuation and an improved living environment, bring great user experience.

## Accurate Temperature Control

According to change trend of indoor ambient temperature, the unit can use PI algorithm to calculate capacity demand percentage of indoor unit, control operating frequency of compressor in real time and realize accurate control of room temperature.

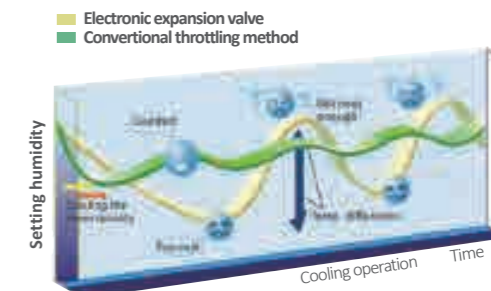

## Flexible And Diversified Matching of Indoor and Outdoor Unit

AUKIA offers a variety indoor unit, more than 100 models of 7 types. Capacity ranges are from 2.2Kw to 14Kw. It is full compliance with residential and light commercial place. Our systems can operate up to 130% of capacity which allows any system to be designed to the customers and applications needs.

## Wide Voltage Design

In country with unstable voltage, KRV can also run stably.

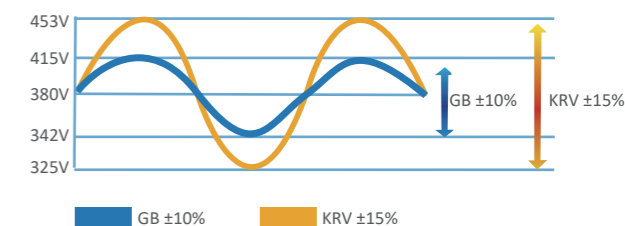



# Cassette Series



One-way Cassette



Two-way Cassette



Compact Four-way Cassette



Four-way Cassette



## FEATURES

■ optional ■ standard

- Independent Dehumidification
- Digital Tube Display
- Sleep Mode
- Built-in Drain Pump
- Fast Cooling/Heating
- 3D Air Flow
- Fresh Air Intake
- Wired Control
- Central Control

## One-Way Cassette

### High-Lift Pump

Standard built-in drain pump with 750mm pumphead.

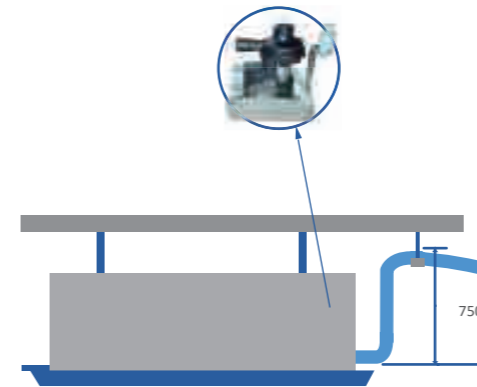

### Fresh Air, Improved Air Quality

Fresh air makes indoor air healthy and comfortable.



## Specification-DC Inverter 50Hz&60Hz

Model	Indoor		KRVNA09H-QR1A	KRVNA12H-QR1A	KRVNA15H-QR1A	KRVNA18H-QR1A	KRVNA24H-QR1A
Capacity	Cooling	kW	2.8	3.6	4.5	5.6	7.1
		kBtu/h	9.6	12.3	15.4	19.1	24.2
	Heating	kW	3.2	4	5	6.3	8
		kBtu/h	10.9	13.6	17.1	21.5	27.3
Electric Data	Power Supply	V-,Hz,Ph	220-240,50(60),1	220-240,50(60),1	220-240,50(60),1	220-240,50(60),1	220-240,50(60),1
	Rated Power	W	40	40	45	45	100
Performance	Air Flow Volume(Hi/Mid/Low)	m <sup>3</sup> /h	530	600	720	910	1000
	Noise Level(Hi/Mid/Low)	dB(A)	36/34/32	38/36/34	41/38/35	43/40/37	44/41/38
	Net(Body)	mm	870 × 460 × 250	870 × 460 × 250	870 × 460 × 250	1180 × 495 × 290	1180 × 495 × 290
	Packing(Body)	mm	1130 × 570 × 355	1130 × 570 × 355	1130 × 570 × 355	1440 × 660 × 385	1440 × 660 × 385
Dimension(WxDxH)	Net(Panel)	mm	1070 × 520 × 33	1070 × 520 × 33	1070 × 520 × 33	1380 × 550 × 33	1380 × 550 × 33
	Packing(Panel)	mm	1085 × 555 × 175	1085 × 555 × 175	1085 × 555 × 175	1400 × 585 × 175	1400 × 585 × 175
	Weight						
Weight	Net/Gross(Body)	kg	24/31	26/33	26/33	38/45	38/45
	Net/Gross(Panel)	kg	3/5	3/5	3/5	5/7	5/7
Refrigerant Type			R410a	R410a	R410a	R410a	R410a
Pipe Diameter	Liquid Side	mm(inch)	6.35(1/4)	6.35(1/4)	6.35(1/4)	6.35(1/4)	9.52(3/8)
		Gas Side	mm(inch)	12.7(1/2)	12.7(1/2)	12.7(1/2)	12.7(1/2)
	Drainage	mm(inch)	R3/4in(DN20)	R3/4in(DN20)	R3/4in(DN20)	R3/4in(DN20)	R3/4in(DN20)
Stuffing Quantity	20/40/40H	unit	88/186/210	88/186/210	88/186/210	60/120/123	60/120/123

Notes:

- 1.Cooling Capacity: Indoor temperature 27°C DB/19°C WB; Outdoor temperature:35°C DB/24°C WB.
- 2.Heating Capacity:Indoor temperature 20°C DB; Outdoor temperature:7°C DB/6°C WB.
- 3.Piping Length:Equivalent piping length:7.5m,level difference:0m.
- 4.Sound level is measured at 1.4m below the unit.
- 5.5.The above designs and specifications are subject to change without prior notice. Final specifications please refer to technical specification provided by sales representative.



## Two-Way Cassette

### Ultra Slim Design

Only 315mm in height, save installation space.

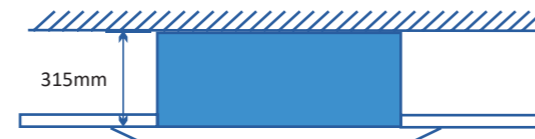

### Quiet Operation

Innovative 3D spiral wind leaf increases air volume and makes the air supply more quietly and smoothly.

### High Airflow

High airflow for high ceiling application guarantees comfort in large space. Guarantees even airflow and temperature throughout the room.

## Specification-DC Inverter 50Hz&60Hz

Model	Indoor		KRVNB09H-QR1A	KRVNB12H-QR1A	KRVNB15H-QR1A	KRVNB18H-QR1A	KRVNB24H-QR1A
Capacity	Cooling	kW	2.8	3.6	4.5	5.6	7.1
		kBtu/h	9.6	12.3	15.4	19.1	24.2
	Heating	kW	3.2	4	5	6.3	8
		kBtu/h	10.9	13.6	17.1	21.5	27.3
Electric Data	Power Supply	V-,Hz,Ph	220-240,50(60),1	220-240,50(60),1	220-240,50(60),1	220-240,50(60),1	220-240,50(60),1
	Rated Power	W	60	62	68	85	94
Performance	Air Flow Volume(Hi/Mid/Low)	m <sup>3</sup> /h	550	620	780	900	1165
	Noise Level(Hi/Mid/Low)	dB(A)	36/32/29	36/32/29	39/35/30	39/35/30	43/39/36
Dimension(WxDxH)	Net(Body)	mm	840 × 520 × 315	840 × 520 × 315	960 × 520 × 315	960 × 520 × 315	1200 × 520 × 315
	Packing(Body)	mm	1145 × 685 × 395	1145 × 685 × 395	1265 × 685 × 395	1265 × 685 × 395	1505 × 685 × 395
	Net(Panel)	mm	1083 × 630 × 33	1083 × 630 × 33	1203 × 630 × 33	1203 × 630 × 33	1443 × 630 × 33
	Packing(Panel)	mm	1100 × 665 × 175	1100 × 665 × 175	1220 × 665 × 175	1220 × 665 × 175	1460 × 665 × 175
Weight	Net/Gross(Body)	kg	31/38	31/38	36/43	36/43	39/46
	Net/Gross(Panel)	kg	4.5/6.5	4.5/6.5	5/7	5/7	7.5/11.5
Refrigerant Type			R410a	R410a	R410a	R410a	R410a
	Liquid Side	mm(inch)	6.35(1/4)	6.35(1/4)	6.35(1/4)	6.35(1/4)	9.52(3/8)
Pipe Diameter	Gas Side	mm(inch)	12.7(1/2)	12.7(1/2)	12.7(1/2)	12.7(1/2)	15.88(5/8)
	Drainage	mm(inch)	R3/4in(DN20)	R3/4in(DN20)	R3/4in(DN20)	R3/4in(DN20)	R3/4in(DN20)
Stuffing Quantity	20/40/40H	unit	64/136/160	64/136/160	56/116/135	56/116/135	54/102/117

Notes:

- 1.Cooling Capacity: Indoor temperature 27°C DB/19°C WB; Outdoor temperature:35°C DB/24°C WB.
- 2.Heating Capacity:Indoor temperature 20°C DB;Outdoor temperature:7°C DB/6°C WB.
- 3.Piping Length:Equivalent piping length:7.5m,level difference:0m.
- 4.Sound level is measured at 1.4m below the unit.
- 5.The above designs and specifications are subject to change without prior notice. Final specifications please refer to technical specification provided by sales representative.

## Compact&Four-Way Cassette

### 5-Segment Heat Exchanger

Innovative 3D spiral wind leaf increases air volume and makes the air supply more quietly and smoothly.



### Built-in Water Drainage Pump

Digital tube displays all contents: indoor temperature, setting temperature, operation mode, etc. Clearly to check the running status, more convenient for trouble shooting.

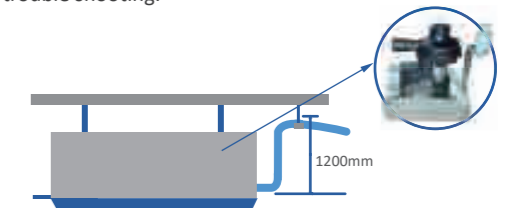

### Optimized Electric Box

Better fire-proof and easy to maintenance.

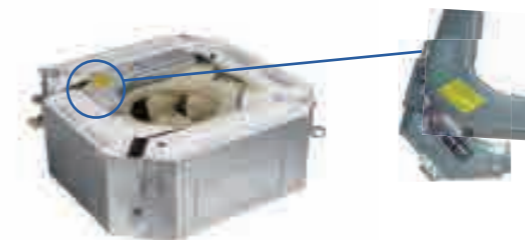

### Ultra Slim Design

Only 250mm in height, save installation space.

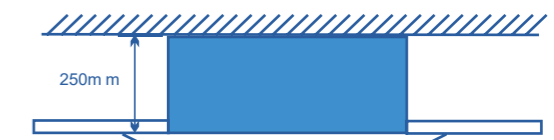

### Fresh Air Intake

Fresh air makes indoor air healthy and comfortable.



### Quiet Operation

Innovative 3D spiral wind leaf increases air volume and makes the air supply more quietly and smoothly.



### Digital Tube Display

Digital tube displays all contents: indoor temperature, setting temperature, operation mode, etc. Clearly to check the running status, more convenient for trouble shooting.





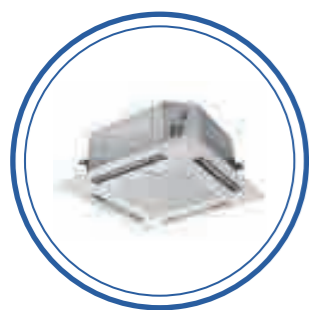

## Four-Way Cassette

### Specification-60Hz

Model	Indoor		KRVNC09H-2R1A	KRVNC12H-2R1A	KRVNC15H-2R1A	KRVNC18H-2R1A	KRVNC24H-2R1A	KRVNC27H-2R1A
Capacity	Cooling	kW	2.8	3.6	4.5	5.6	7.1	8.0
		kBtu/h	9.6	12.3	15.4	19.1	24.2	27.3
	Heating	kW	3.0	4.3	5.0	6.3	8.0	10.0
		kBtu/h	10.2	14.7	17.1	21.5	27.3	34.1
Electric Data	Power Supply	V~,Hz,Ph	220-240,60,1	220-240,60,1	220-240,60,1	220-240,60,1	220-240,60,1	220-240,60,1
	Rated Power	W	84	84	96	96	95	95
Performance	Air Flow Volume(Hi/Mid/Low)	m³/h	620/496/434	620/496/434	850/680/595	850/680/595	1250/1040/910	1250/1040/910
	Noise Level(Hi/Mid/Low)	dB(A)	38/35/32	38/35/32	39/36/33	39/36/33	38/34/30	38/34/30
Dimension (WxDxH)	Net(Body)	mm	615 × 615 × 263	615 × 615 × 263	615 × 615 × 263	615 × 615 × 263	835 × 835 × 250	835 × 835 × 250
	Packing(Body)	mm	700 × 700 × 330	700 × 700 × 330	700 × 700 × 330	700 × 700 × 330	910 × 910 × 310	910 × 910 × 310
	Net(Panel)	mm	650 × 650 × 55	650 × 650 × 55	650 × 650 × 55	650 × 650 × 55	950 × 950 × 55	950 × 950 × 55
	Packing(Panel)	mm	710 × 710 × 80	710 × 710 × 80	710 × 710 × 80	710 × 710 × 80	1000 × 1000 × 100	1000 × 1000 × 100
Weight	Net/Gross(Body)	kg	20/25	20/25	20/25	20/25	27/34	27/34
	Net/Gross(Panel)	kg	3/5	3/5	3/5	3/5	5/7	5/7
Refrigerant Type			6.35(1/4)	6.35(1/4)	6.35(1/4)	6.35(1/4)	9.52(3/8)	9.52(3/8)
	Liquid Side	mm(inch)	12.7(1/2)	12.7(1/2)	12.7(1/2)	12.7(1/2)	15.88(5/8)	15.88(5/8)
Pipe Diameter	Gas Side	mm(inch)	DN20(R3/4)	DN20(R3/4)	DN20(R3/4)	DN20(R3/4)	DN20(R3/4)	DN20(R3/4)
	Drainage	mm(inch)	140/312/354	140/312/354	140/312/354	140/312/354	78/168/184	78/168/184
Stuffing Quantity	20/40/40H	unit	140/312/354	140/312/354	140/312/354	140/312/354	78/168/184	78/168/184

### Specification-60Hz

Model	Indoor		KRVNC30H-2R1A	KRVNC34H-2R1A	KRVNC38H-2R1A	KRVNC43H-2R1A	KRVNC48H-2R1A
Capacity	Cooling	kW	9.0	10.0	11.2	12.5	14.0
		kBtu/h	30.7	34.1	38.2	42.7	47.8
	Heating	kW	11.0	12.0	12.8	13.3	15.0
		kBtu/h	37.5	40.9	43.7	45.4	51.2
Electric Data	Power Supply	V~,Hz,Ph	220-240,60,1	220-240,60,1	220-240,60,1	220-240,60,1	220-240,60,1
	Rated Power	W	122	122	165	165	165
Performance	Air Flow Volume(Hi/Mid/Low)	m³/h	1500/1200/1050	1500/1200/1050	1800/1440/1260	1800/1440/1260	1800/1440/1260
	Noise Level(Hi/Mid/Low)	dB(A)	41/37/34	41/37/34	41/38/35	41/38/35	41/38/35
Dimension (WxDxH)	Net(Body)	mm	835 × 835 × 250	835 × 835 × 250	835 × 835 × 290	835 × 835 × 290	835 × 835 × 290
	Packing(Body)	mm	910 × 910 × 310	910 × 910 × 310	910 × 910 × 350	910 × 910 × 350	910 × 910 × 350
	Net(Panel)	mm	950 × 950 × 55	950 × 950 × 55	950 × 950 × 55	950 × 950 × 55	950 × 950 × 55
	Packing(Panel)	mm	1000 × 1000 × 100	1000 × 1000 × 100	1000 × 1000 × 100	1000 × 1000 × 100	1000 × 1000 × 100
Weight	Net/Gross(Body)	kg	28/35	28/35	30/37	30/37	30/37
	Net/Gross(Panel)	kg	5/7	5/7	5/7	5/7	5/7
Refrigerant Type			9.52(3/8)	9.52(3/8)	9.52(3/8)	9.52(3/8)	9.52(3/8)
	Liquid Side	mm(inch)	15.88(5/8)	15.88(5/8)	19.05(3/4)	19.05(3/4)	19.05(3/4)
Pipe Diameter	Gas Side	mm(inch)	DN20(R3/4)	DN20(R3/4)	DN20(R3/4)	DN20(R3/4)	DN20(R3/4)
	Drainage	mm(inch)	78/168/184	78/168/184	68/150/170	68/150/170	68/150/170
Stuffing Quantity	20/40/40H	unit	78/168/184	78/168/184	68/150/170	68/150/170	68/150/170

Notes:

- Cooling Capacity: Indoor temperature 27°C DB/19°C WB; Outdoor temperature: 35°C DB/24°C WB.
- Heating Capacity: Indoor temperature 20°C DB; Outdoor temperature: 7°C DB/6°C WB.
- Piping Length: Equivalent piping length: 7.5m, level difference: 0m.
- Sound level is measured at 1.4m below the unit.
- The above designs and specifications are subject to change without prior notice. Final specifications please refer to technical specification provided by sales representative.

## Duct Series



Slim Duct



Mid ESP Duct



High ESP Duct



Fresh Air Processor



### FEATURES

■ optional ■ standard



Wired Control



Intelligent Defrosting



Sleep Mode



Fast Cooling/Heating



3D Air Flow



Fresh Air Intake



Remote Control



Central Control

# Slim Duct

## 2 Ways Draining Connection

There two outlet in left and right, both left and right side of unit are possible for drainage hose connection, easy for installation.



## Built-in Water Pump

The built-in pump can lift condensing water up to 700mm high from the drainage pan.

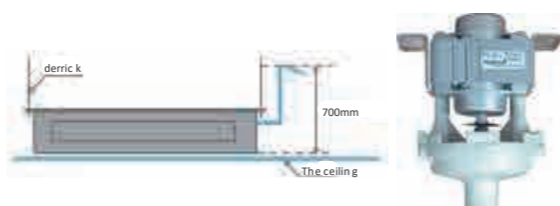

## Ultra Slim Design

The thickness is only 185mm, save installation space.



## Digital Tube Display (Optional)

Digital tube displays all contents: indoor temperature, setting temperature, operation mode, etc. Clearly to check the running status, more convenient for trouble shooting.



## Flexible Air Intake Options

Air intake from rear as standard, from bottom is optional. The size of the plate from bottom is the same as the flange from back, which makes it convenient to change installation style due to different decoration requirements.



## Silence Operation

Innovative centrifugal fan for large diameter and a new design of the spiral duct system equipped with high-quality motor at the same time, making the air supply more quiet and smooth. The lowest noise is 18 db(A). The lowest operation noise is 18 db(A), the industry's most advanced mute value.

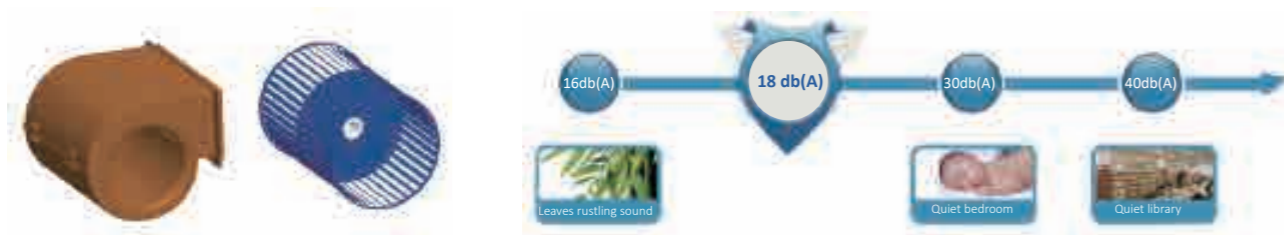

# Slim Duct

## Specification-DC Inverter 50Hz&60Hz

Model	Indoor		KRVNL07H-QR1A	KRVNL09H-QR1A	KRVNL12H-QR1A	KRVNL15H-QR1A	KRVNL18H-QR1A	KRVNL24H-QR1A
Capacity	Cooling	kW	2.2	2.8	3.6	4.5	5.6	7.1
		kBtu/h	7.5	9.6	12.3	15.4	19.1	24.2
	Heating	kW	2.5	3.0	4.3	5.0	6.0	8.0
Electric Data	Power Supply	V~,Hz,Ph	220-240,50(60),1	220-240,50(60),1	220-240,50(60),1	220-240,50(60),1	220-240,50(60),1	220-240,50(60),1
	Rated Power	W	55	55	60	91	91	110
	Air Flow Volume(Hi/Mid/Low)	m³/h	480/390/320	480/390/320	560/430/390	850/680/575	850/680/575	1000/810/685
Performance	Noise Level(Hi/Mid/Low)	dB(A)	30/26/23	30/26/23	32/28/25	38/35/32	38/35/32	39/36/32
	External Static Pressure(ESP)	Pa	10/30	10/30	10/30	10/30	10/30	10/30
	Dimension Net	mm	840 × 460 × 185	840 × 460 × 185	840 × 460 × 185	1160 × 460 × 185	1160 × 460 × 185	1160 × 460 × 185
Weight	Net/Gross	kg	15.5/19	15.5/19	16.5/20	20/24	20/24	22/26
	Liquid Side	mm(inch)	6.35(1/4)	6.35(1/4)	6.35(1/4)	6.35(1/4)	6.35(1/4)	9.52(3/8)
Pipe Diameter	Gas Side	mm(inch)	9.52(3/8)	9.52(3/8)	12.7(1/2)	12.7(1/2)	12.7(1/2)	15.88(5/8)
	Drainage	mm(inch)	DN20(R3/4)	DN20(R3/4)	DN20(R3/4)	DN20(R3/4)	DN20(R3/4)	DN20(R3/4)
Stuffing Quantity	20/40/40H	unit	198/414/460	198/414/460	198/414/460	153/306/340	153/306/340	153/306/340

## Specification-50Hz

Model	Indoor		KRVNL07H-4R1A	KRVNL09H-4R1A	KRVNL12H-4R1A	KRVNL15H-4R1A	KRVNL18H-4R1A	KRVNL24H-4R1A
Capacity	Cooling	kW	2.2	2.8	3.6	4.5	5.6	7.1
		kBtu/h	7.5	9.6	12.3	15.4	19.1	24.2
	Heating	kW	2.5	3.0	4.3	5.0	6.0	8.0
Electric Data	Power Supply	V~,Hz,Ph	220-240,50,1	220-240,50,1	220-240,50,1	220-240,50,1	220-240,50,1	220-240,50,1
	Rated Power	W	59	59	65	91	91	113
	Air Flow Volume(Hi/Mid/Low)	m³/h	480/390/320	480/390/320	560/430/390	850/680/575	850/680/575	1000/810/685
Performance	Noise Level(Hi/Mid/Low)	dB(A)	30/26/23	30/26/23	32/28/25	38/35/32	38/35/32	39/36/32
	External Static Pressure(ESP)	Pa	10/30	10/30	10/30	10/30	10/30	10/30
	Dimension Net	mm	840 × 460 × 185	840 × 460 × 185	840 × 460 × 185	1160 × 460 × 185	1160 × 460 × 185	1160 × 460 × 185
Weight	Net/Gross	kg	15.5/19	15.5/19	16.5/20	20/24	20/24	22/26
	Liquid Side	mm(inch)	6.35(1/4)	6.35(1/4)	6.35(1/4)	6.35(1/4)	6.35(1/4)	9.52(3/8)
Pipe Diameter	Gas Side	mm(inch)	9.52(3/8)	9.52(3/8)	12.7(1/2)	12.7(1/2)	12.7(1/2)	15.88(5/8)
	Drainage	mm(inch)	DN20(R3/4)	DN20(R3/4)	DN20(R3/4)	DN20(R3/4)	DN20(R3/4)	DN20(R3/4)
Stuffing Quantity	20/40/40H	unit	198/414/460	198/414/460	198/414/460	153/306/340	153/306/340	153/306/340

## Specification-60Hz

Model	Indoor		KRVNL07H-2R1A	KRVNL09H-2R1A	KRVNL12H-2R1A	KRVNL15H-2R1A	KRVNL18H-2R1A	KRVNL24H-2R1A
Capacity	Cooling	kW	2.2	2.8	3.6	4.5	5.6	7.1
		kBtu/h	7.5	9.6	12.3	15.4	19.1	24.2
	Heating	kW	2.5	3.0	4.3	5.0	6.0	8.0
Electric Data	Power Supply	V~,Hz,Ph	220-240,60,1	220-240,60,1	220-240,60,1	220-240,60,1	220-240,60,1	220-240,60,1
	Rated Power	W	59	59	65	97	97	113
	Air Flow Volume(Hi/Mid/Low)	m³/h	480/390/320	480/390/320	560/430/390	850/680/575	850/680/575	1000/810/685
Performance	Noise Level(Hi/Mid/Low)	dB(A)	30/26/23	30/26/23	32/28/25	38/35/32	38/35/32	39/36/32
	External Static Pressure(ESP)	Pa	10/30	10/30	10/30	10/30	10/30	10/30
	Dimension Net	mm	840 × 460 × 185	840 × 460 × 185	840 × 460 × 185	1160 × 460 × 185	1160 × 460 × 185	1160 × 460 × 185
Weight	Net/Gross	kg	15.5/19	15.5/19	16.5/20	20/24	20/24	22/26
	Liquid Side	mm(inch)	6.35(1/4)	6.35(1/4)	6.35(1/4)	6.35(1/4)	6.35(1/4)	9.52(3/8)
Pipe Diameter	Gas Side	mm(inch)	9.52(3/8)	9.52(3/8)	12.7(1/2)	12.7(1/2)	12.7(1/2)	15.88(5/8)
	Drainage	mm(inch)	DN20(R3/4)	DN20(R3/4)	DN20(R3/4)	DN20(R3/4)	DN20(R3/4)	DN20(R3/4)
Stuffing Quantity	20/40/40H	unit	198/414/460	198/414/460	198/414/460	153/306/340	153/306/340	153/306/340

Notes:

- 1.Cooling Capacity: Indoor temperature 27°C DB/19°C WB; Outdoor temperature:35°C DB/24°C WB.
- 2.Heating Capacity:Indoor temperature 20°C DB;Outdoor temperature:7°C DB/6°C WB.
- 3.Piping Length:Equivalent piping length:7.5m,level difference:0m.
- 4.Sound level is measured at 1.4m below the unit.
- 5.The above designs and specifications are subject to change without prior notice. Final specifications please refer to technical specification provided by sales representative.

# Mid ESP Duct

## Flexible Air Intake Options

Air intake from rear as standard, from bottom is optional. The size of the plate from bottom is the same as the flange from back, which makes it convenient to change installation style according to different decoration requirements.

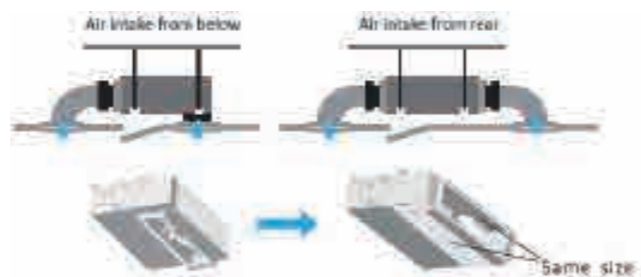

## Built In With Water Pump (Optional)

The built-in pump can lift condensing water up to 1200mm high from the drainage pan.

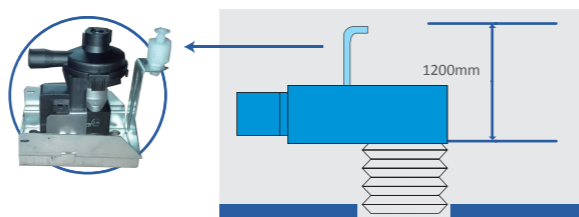

## Optional ESP

50Pa and 80Pa are both optional.

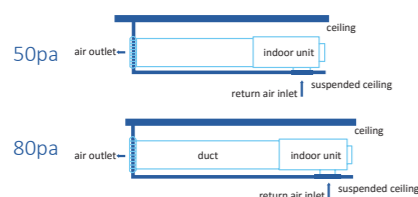

## Ultra Slim Design

Only 290mm in height, save installation space.

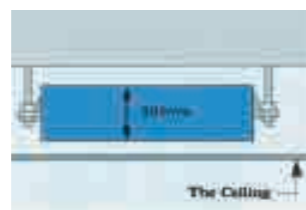

## Fresh Air Intake

Fresh air makes indoor air healthy and comfortable.

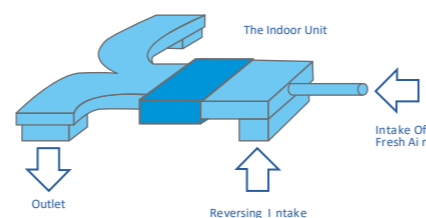

## Applicable to A Variety Of Room Types

Specific ESP design can be applied to various room types easily, like rooms of L type or U type; the air outlet can be set separately from the indoor unit, so the air flow can be equally distributed even the room is in irregular structure.

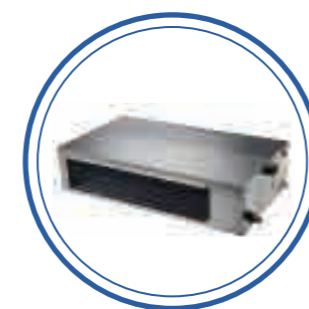
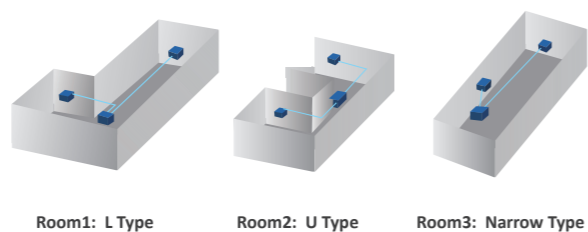

# Mid ESP Duct

## Specification-DC Inverter 50Hz&60Hz

Model	Indoor		KRVNM15H-QR1A	KRVNM18H-QR1A	KRVNM24H-QR1A	KRVNM27H-QR1A	KRVNM30H-QR1A
Capacity	Cooling	kW	4.5	5.6	7.1	8.0	9.0
		kBtu/h	15.4	19.1	24.2	27.3	30.7
	Heating	kW	5.0	6.0	8.0	10.0	11.0
		kBtu/h	17.1	20.5	27.3	34.1	37.5
Electric Data	Power Supply	V~,Hz,Ph	220-240,50(60),1	220-240,50(60),1	220-240,50(60),1	220-240,50(60),1	220-240,50(60),1
	Rated Power	W	150	150	190	200	200
Performance	Air Flow Volume(Hi/Mid/Low)	m³/h	950/760/665	950/760/665	1200/960/840	1500/1200/1050	1500/1200/1050
	Noise Level(Hi/Mid/Low)	dB(A)	42/39/37	42/39/37	45/42/39	48/45/42	48/45/42
	External Static Pressure(ESP)	Pa	50/80	50/80	50/80	50/80	50/80
Dimension	Net	mm	890 × 785 × 290	890 × 785 × 290	890 × 785 × 290	890 × 785 × 290	890 × 785 × 290
	Packing	mm	1100 × 880 × 360	1100 × 880 × 360	1100 × 880 × 360	1100 × 880 × 360	1100 × 880 × 360
Weight	Net/Gross	kg	35/41	35/41	37/43	37/43	37/43
	Liquid Side	mm(inch)	6.35(1/4)	6.35(1/4)	9.52(3/8)	9.52(3/8)	9.52(3/8)
Pipe Diameter	Gas Side	mm(inch)	12.7(1/2)	12.7(1/2)	15.88(5/8)	15.88(5/8)	15.88(5/8)
	Drainage	mm(inch)	DN20(R3/4)	DN20(R3/4)	DN20(R3/4)	DN20(R3/4)	DN20(R3/4)
Stuffing Quantity	20/40/40H	unit	72/156/182	72/156/182	72/156/182	72/156/182	72/156/182

## Specification-DC Inverter 50Hz&60Hz

Model	Indoor		KRVNM34H-QR1A	KRVNM38H-QR1A	KRVNM43H-QR1A	KRVNM48H-QR1A	KRVNM51H-QR1A
Capacity	Cooling	kW	10.0	11.2	12.5	14.0	15.0
		kBtu/h	34.1	38.2	42.7	47.8	51.2
	Heating	kW	12.0	12.8	13.3	15.0	16.0
		kBtu/h	40.9	43.7	45.4	51.2	54.6
Electric Data	Power Supply	V~,Hz,Ph	220-240,50(60),1	220-240,50(60),1	220-240,50(60),1	220-240,50(60),1	220-240,50(60),1
	Rated Power	W	200	320	320	320	320
Performance	Air Flow Volume(Hi/Mid/Low)	m³/h	1500/1200/1050	2000/1600/1400	2000/1600/1400	2000/1600/1400	2200/1760/1540
	Noise Level(Hi/Mid/Low)	dB(A)	48/45/42	51/43/40	51/43/40	51/43/40	51/43/40
	External Static Pressure(ESP)	Pa	50/80	50/80	50/80	50/80	50/80
Dimension	Net	mm	890 × 785 × 290	1250 × 785 × 290	1250 × 785 × 290	1250 × 785 × 290	1250 × 785 × 290
	Packing	mm	1100 × 880 × 360	1460 × 880 × 360	1460 × 880 × 360	1460 × 880 × 360	1460 × 880 × 360
Weight	Net/Gross	kg	37/43	53/60	53/60	53/60	53/60
	Liquid Side	mm(inch)	9.52(3/8)	9.52(3/8)	9.52(3/8)	9.52(3/8)	9.52(3/8)
Pipe Diameter	Gas Side	mm(inch)	15.88(5/8)	15.88(5/8)	15.88(5/8)	15.88(5/8)	15.88(5/8)
	Drainage	mm(inch)	DN20(R3/4)	DN20(R3/4)	DN20(R3/4)	DN20(R3/4)	DN20(R3/4)
Stuffing Quantity	20/40/40H	unit	72/156/182	60/126/147	60/126/147	60/126/147	60/126/147

## Specification-50Hz

Model	Indoor		KRVMD-H045/4R1A	KRVMD-H056/4R1A	KRVMD-H071/4R1A	KRVMD-H080/4R1A	KRVMD-H090/4R1A
Capacity	Cooling	kW	4.5	5.6	7.1	8.0	9.0
		kBtu/h	15.4	19.1	24.2	27.3	30.7
	Heating	kW	5.0	6.0	8.0	10.0	11.0
		kBtu/h	17.1	20.5	27.3	34.1	37.5
Electric Data	Power Supply	V~,Hz,Ph	220-240,50,1	220-240,50,1	220-240,50,1	220-240,50,1	220-240,50,1
	Rated Power	W	150	150	220	250	250
Performance	Air Flow Volume(Hi/Mid/Low)	m³/h	950/760/665	950/760/665	1200/960/840	1500/1200/1050	1500/1200/1050
	Noise Level(Hi/Mid/Low)	dB(A)	42/39/37	42/39/37	45/42/39	48/45/42	48/45/42
	External Static Pressure(ESP)	Pa	50/80	50/80	50/80	50/80	50/80
Dimension	Net	mm	890 × 785 × 290	890 × 785 × 290	890 × 785 × 290	890 × 785 × 290	890 × 785 × 290
	Packing	mm	1100 × 880 × 360	1100 × 880 × 360	1100 × 880 × 360	1100 × 880 × 360	1100 × 880 × 360
Weight	Net/Gross	kg	35/41	35/41	37/43	37/43	37/43
	Liquid Side	mm(inch)	6.35(1/4)	6.35(1/4)	9.52(3/8)	9.52(3/8)	9.52(3/8)
Pipe Diameter	Gas Side	mm(inch)	12.7(1/2)	12.7(1/2)	15.88(5/8)	15.88(5/8)	15.88(5/8)
	Drainage	mm(inch)	DN20(R3/4)	DN20(R3/4)	DN20(R3/4)	DN20(R3/4)	DN20(R3/4)
Stuffing Quantity	20/40/40H	unit	72/156/182	72/156/182	72/156/182	72/156/182	72/156/182

Notes:  
 1.Cooling Capacity: Indoor temperature 27°C DB/19°C WB; Outdoor temperature: 35°C DB/24°C WB.  
 2.Heating Capacity: Indoor temperature 20°C DB; Outdoor temperature: 7°C DB/6°C WB.  
 3.Piping Length: Equivalent piping length: 7.5m, level difference: 0m.  
 4.Sound level is measured at 1.4m below the unit.  
 5.The above designs and specifications are subject to change without prior notice. Final specifications please refer to technical specification provided by sales representative.





## High ESP Duct

### Specification-50Hz

Model	Indoor		KRVNH38H-4R1A	KRVNH43H-4R1A	KRVNH48H-4R1A	KRVNH51H-4R1A
Capacity	Cooling	kW	11.2	12.5	14.0	15.0
		kBtu/h	38.2	42.7	47.8	51.2
Capacity	Heating	kW	12.8	13.3	15.0	16.0
		kBtu/h	43.7	45.4	51.2	54.6
Electric Data	Power Supply	V~,Hz,Ph	220-240,50,1	220-240,50,1	220-240,50,1	220-240,50,1
	Rated Power	W	600	600	600	600
Performance	Air Flow Volume(Hi/Mid/Low)	m³/h	2000/1600/1400	2000/1600/1400	2000/1600/1400	2000/1600/1400
	Noise Level(Hi/Mid/Low)	dB(A)	60/57/51	60/57/51	60/57/51	60/57/51
	External Static Pressure(ESP)	Pa	196	196	196	196
Dimension	Net	mm	1200 × 719 × 380	1200 × 719 × 380	1200 × 719 × 380	1200 × 719 × 380
	Packing	mm	1235 × 760 × 415	1235 × 760 × 415	1235 × 760 × 415	1235 × 760 × 415
Weight	Net/Gross	kg	56/59	56/59	56/59	56/59
	Liquid Side	mm(inch)	9.52(3/8)	9.52(3/8)	9.52(3/8)	9.52(3/8)
Pipe Diameter	Gas Side	mm(inch)	19.05(3/4)	19.05(3/4)	19.05(3/4)	19.05(3/4)
	Drainage	mm(inch)	DN20(R3/4)	DN20(R3/4)	DN20(R3/4)	DN20(R3/4)
Stuffing Quantity	20/40/40H	unit	65/140/168	65/140/168	65/140/168	65/140/168

### Specification-50Hz

Model	Indoor		KRVNH76H-4R1A	KRVNH96H-4R1A	KRVNH150H-4R1A	KRVNH190H-4R1A
Capacity	Cooling	kW	22.4	28.0	45.0	56.0
		kBtu/h	76.4	95.5	153.5	191.1
Capacity	Heating	kW	25.0	31.5	49.5	61.5
		kBtu/h	85.3	107.5	168.9	209.8
Electric Data	Power Supply	V~,Hz,Ph	220-240,50,1	220-240,50,1	380-415,50,3	380-415,50,3
	Rated Power	W	1250	1250	2220	2220
Performance	Air Flow Volume(Hi/Mid/Low)	m³/h	4000/3200/2600	4000/3200/2600	8000	8000
	Noise Level(Hi/Mid/Low)	dB(A)	55	55	63	63
	External Static Pressure(ESP)	Pa	220	220	200	200
Dimension	Net	mm	1350 × 700 × 460	1350 × 700 × 460	2115 × 990 × 855	2115 × 990 × 855
	Packing	mm	1540 × 810 × 610	1540 × 810 × 610	2225 × 1025 × 1015	2225 × 1025 × 1015
Weight	Net/Gross	kg	91/110	91/110	225/260	225/260
	Liquid Side	mm(inch)	12.7(1/2)	12.7(1/2)	12.7(1/2)x2	12.7(1/2)x2
Pipe Diameter	Gas Side	mm(inch)	22.2(7/8)	22.2(7/8)	22.2(7/8)x2	22.2(7/8)x2
	Drainage	mm(inch)	DN25	DN25	DN25	DN25
Stuffing Quantity	20/40/40H	unit	30/63/84	30/63/84	10/22/22	10/22/22

### Specification-60Hz

Model	Indoor		KRVNH38H-2R1A	KRVNH43H-2R1A	KRVNH48H-2R1A	KRVNH51H-2R1A
Capacity	Cooling	kW	11.2	12.5	14.0	15.0
		kBtu/h	38.2	42.7	47.8	51.2
Capacity	Heating	kW	12.8	13.3	15.0	16.0
		kBtu/h	43.7	45.4	51.2	54.6
Electric Data	Power Supply	V~,Hz,Ph	220-240,60,1	220-240,60,1	220-240,60,1	220-240,60,1
	Rated Power	W	720	720	720	720
Performance	Air Flow Volume(Hi/Mid/Low)	m³/h	2000/1600/1400	2000/1600/1400	2000/1600/1400	2000/1600/1400
	Noise Level(Hi/Mid/Low)	dB(A)	60/57/51	60/57/51	60/57/51	60/57/51
	External Static Pressure(ESP)	Pa	196	196	196	196
Dimension	Net	mm	1200 × 719 × 380	1200 × 719 × 380	1200 × 719 × 380	1200 × 719 × 380
	Packing	mm	1235 × 760 × 415	1235 × 760 × 415	1235 × 760 × 415	1235 × 760 × 415
Weight	Net/Gross	kg	56/59	56/59	56/59	56/59
	Liquid Side	mm(inch)	9.52(3/8)	9.52(3/8)	9.52(3/8)	9.52(3/8)
Pipe Diameter	Gas Side	mm(inch)	19.05(3/4)	19.05(3/4)	19.05(3/4)	19.05(3/4)
	Drainage	mm(inch)	DN20(R3/4)	DN20(R3/4)	DN20(R3/4)	DN20(R3/4)
Stuffing Quantity	20/40/40H	unit	65/140/168	65/140/168	65/140/168	65/140/168

Notes:

- 1.Cooling Capacity: Indoor temperature 27°C DB/19°C WB; Outdoor temperature:35°C DB/24°C WB.
- 2.Heating Capacity:Indoor temperature 20°C DB; Outdoor temperature:7°C DB/6°C WB.
- 3.Piping Length:Equivalent piping length:7.5m,level difference:0m.
- 4.Sound level is measured at 1.4m below the unit.
- 5.The above designs and specifications are subject to change without prior notice. Final specifications please refer to technical specification provided by sales representative.

## Fresh Air Processor

### Innovative Air Supply Technology For Excellent Room Temperature Control

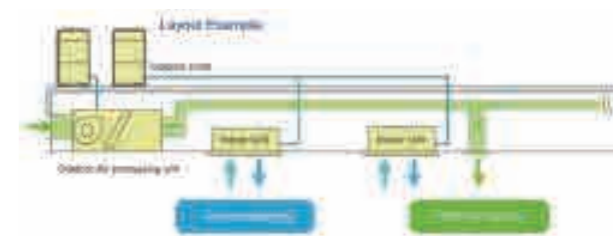

Fall all models, return air bellow and air filter are standard configuration.

### Long Distance Air Supply

High ESP makes the air supply distance up to 50m.

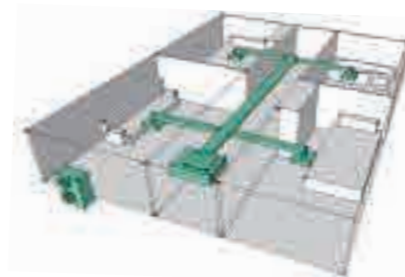

### Fresh Air Intake

Fresh air makes indoor air healthy and comfortable.

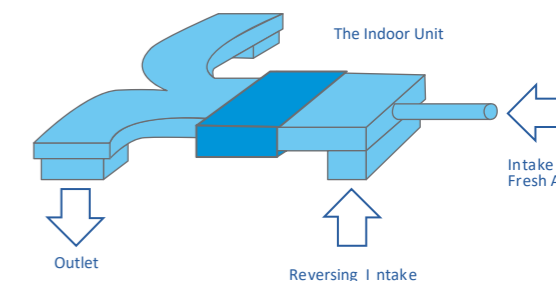

### Applicable To A Variety Of Room Types

Specific ESP design can be applied to various room types easily, like rooms of L type or U type; the air outlet can be set separately from the indoor unit, so the air flow can be equally distributed even the room is in irregular structure.

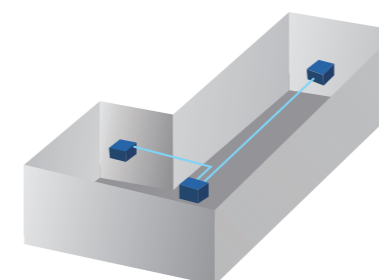

Room1: L Type

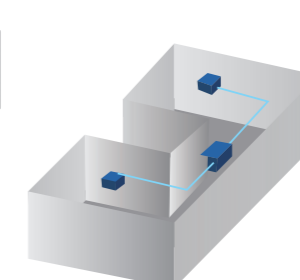

Room2: U Type

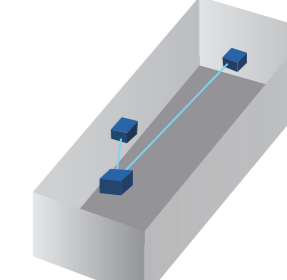

Room3: Narrow Type



## Fresh Air Processor

### Specification-DC Inverter 50Hz&60Hz

Model	Indoor		KRVNF76H-QR1B	KRVNF96H-QR1B
Capacity	Cooling	kW	22.4	28.0
		kBtu/h	76.4	95.5
	Heating	kW	18.0	22.0
kBtu/h		61.4	75.1	
Electric Data	Power Supply	V~,Hz,Ph	220~240,50(60),1	220~240,50(60),1
	Rated Power	W	800	800
Performance	Air Flow Volume(Hi/Mid/Low)	m <sup>3</sup> /h	3200	3200
	Noise Level(Hi/Mid/Low)	dB(A)	55	55
	External Static Pressure(ESP)	Pa	220	220
Dimension (WxDxH)	Net	mm	1350 × 700 × 460	1350 × 700 × 460
	Packing	mm	1540 × 810 × 610	1540 × 810 × 610
Weight	Net/Gross	kg	91/110	91/110
	Liquid Side	mm(inch)	12.7(1/2)	12.7(1/2)
Pipe Diameter	Gas Side	mm(inch)	22.2(7/8)	22.2(7/8)
	Drainage	mm	DN25	DN25
Stuffing Quantity	20/40/40H	unit	30/63/84	30/63/84

### Specification-50Hz

Model	Indoor		KRVNF76H-4R1B	KRVNF96H-4R1B	KRVNF150H-4R1A	KRVNF190H-4R1A
Capacity	Cooling	kW	22.4	28.0	45.0	56.0
		kBtu/h	76.4	95.5	153.5	191.1
	Heating	kW	18.0	22.0	49.5	61.5
kBtu/h		61.4	75.1	168.9	209.8	
Electric Data	Power Supply	V~,Hz,Ph	220~240,50,1	220~240,50,1	380~415,50,3	380~415,50,3
	Rated Power	W	1000	1000	1520	1520
Performance	Air Flow Volume(Hi/Mid/Low)	m <sup>3</sup> /h	3200	3200	4000	5000
	Noise Level(Hi/Mid/Low)	dB(A)	55	55	57	59
	External Static Pressure(ESP)	Pa	220	220	220	220
Dimension (WxDxH)	Net	mm	1350 × 700 × 460	1350 × 700 × 460	1820 × 990 × 855	2115 × 990 × 855
	Packing	mm	1540 × 810 × 610	1540 × 810 × 610	1935 × 1025 × 1015	2225 × 1025 × 1015
Weight	Net/Gross	kg	91/110	91/110	150/170	225/255
	Liquid Side	mm(inch)	12.7(1/2)	12.7(1/2)	12.7(1/2)x2	12.7(1/2)x2
Pipe Diameter	Gas Side	mm(inch)	22.2(7/8)	22.2(7/8)	22.2(7/8)x2	22.2(7/8)x2
	Drainage	mm	DN25	DN25	DN25	DN25
Stuffing Quantity	20/40/40H	unit	30/63/84	30/63/84	10/22/22	10/22/22

#### Notes:

- 1.Cooling Capacity: Indoor temperature 27°C DB/19°C WB;Outdoor temperature:35°C DB/24°C WB.
- 2.Heating Capacity:Indoor temperature 20°C DB;Outdoor temperature:7°C DB/6°C WB.
- 3.Piping Length:Equivalent piping length:7.5m,level difference:0m.
- 4.Sound level is measured at 1.4m from the air outlet
- 5.The above designs and specifications are subject to change without prior notice. Final specifications please refer to technical specification provided by sales representative.

#### Connection Conditions:

The following restrictions must be observed in order to maintain the indoor units connected to the same system.  
 When outdoor-air processing units are connected,the total connection capacity must be within 50% to 100% of that of the outdoor units.  
 When outdoor-air processing units are standard indoor units are connected,the total connection capacity of the outdoor-processing units must not exceed 30% of that of the outdoor units.  
 Outdoor-air processing units can be used without indoor units.

## Ceiling&Floor Series



### FEATURES

■ optional ■ standard

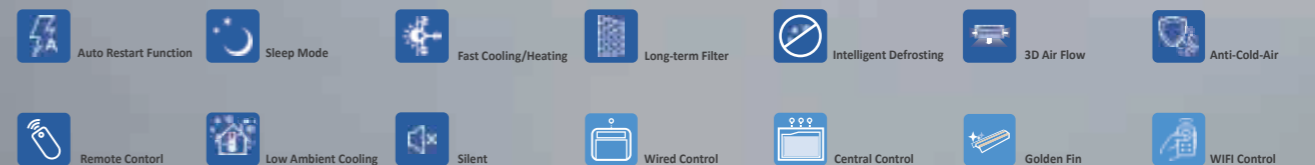







## Ceiling & Floor

### Specification-50Hz

Model	Indoor		KRVNE30H-4R1A	KRVNE34H-4R1A	KRVNE38H-4R1A	KRVNE43H-4R1A	KRVNE48H-4R1A
Capacity	Cooling	kW	9.0	10.0	11.2	12.5	14.0
		kBtu/h	30.7	34.1	38.2	42.7	47.8
	Heating	kW	11.0	12.0	12.8	13.3	15.0
		kBtu/h	37.5	40.9	43.7	45.4	51.2
Electric Data	Power Supply	V~,Hz,Ph	220-240,50,1	220-240,50,1	220-240,50,1	220-240,50,1	220-240,50,1
	Rated Power	W	140	140	210	210	210
Performance	Air Flow Volume(Hi/Mid/Low)	m³/h	1500/1200/1050	1500/1200/1050	1800/1440/1260	1800/1440/1260	1800/1440/1260
	Noise Level(Hi/Mid/Low)	dB(A)	47/44/41	47/44/41	48/45/42	48/45/42	48/45/42
Dimension (WxDxH)	Net	mm	1280 × 660 × 205	1280 × 660 × 205	1631 × 660 × 205	1631 × 660 × 205	1631 × 660 × 205
	Packing	mm	1360 × 720 × 290	1360 × 720 × 290	1710 × 720 × 290	1710 × 720 × 290	1710 × 720 × 290
Weight	Net/Gross	kg	35/39	35/39	45/51	45/51	45/51
	Liquid Side	mm(inch)	9.52(3/8)	9.52(3/8)	9.52(3/8)	9.52(3/8)	9.52(3/8)
Pipe Diameter	Gas Side	mm(inch)	15.88(5/8)	15.88(5/8)	15.88(5/8)	15.88(5/8)	15.88(5/8)
	Drainage	mm(inch)	DN20(R3/4)	DN20(R3/4)	DN20(R3/4)	DN20(R3/4)	DN20(R3/4)
Stuffing Quantity	20/40/40H	unit	96/200/225	96/200/225	80/168/189	80/168/189	80/168/189

### Specification-60Hz

Model	Indoor		KRVNE09H-2R1A	KRVNE12H-2R1A	KRVNE15H-2R1A	KRVNE18H-2R1A	KRVNE24H-2R1A	KRVNE27H-2R1A
Capacity	Cooling	kW	2.8	3.6	4.5	5.6	7.1	8.0
		kBtu/h	9.6	12.3	15.4	19.1	24.2	27.3
	Heating	kW	3.0	4.3	5.0	6.0	8.0	10.0
		kBtu/h	10.2	14.7	17.1	20.5	27.3	34.1
Electric Data	Power Supply	V~,Hz,Ph	220-240,60,1	220-240,60,1	220-240,60,1	220-240,60,1	220-240,60,1	220-240,60,1
	Rated Power	W	96	96	96	96	168	168
Performance	Air Flow Volume(Hi/Mid/Low)	m³/h	450/360/315	630/504/441	950/760/665	950/760/665	1300/1040/910	1500/1200/1050
	Noise Level(Hi/Mid/Low)	dB(A)	37/34/31	39/36/33	42/39/36	42/39/36	45/42/39	47/44/41
Dimension (WxDxH)	Net	mm	929 × 660 × 205	929 × 660 × 205	929 × 660 × 205	929 × 660 × 205	1280 × 660 × 205	1280 × 660 × 205
	Packing	mm	1010 × 720 × 290	1010 × 720 × 290	1010 × 720 × 290	1010 × 720 × 290	1360 × 720 × 290	1360 × 720 × 290
Weight	Net/Gross	kg	26/29	26/29	26/29	26/29	35/39	35/39
	Liquid Side	mm(inch)	6.35(1/4)	6.35(1/4)	6.35(1/4)	6.35(1/4)	9.52(3/8)	9.52(3/8)
Pipe Diameter	Gas Side	mm(inch)	12.7(1/2)	12.7(1/2)	12.7(1/2)	12.7(1/2)	15.88(5/8)	15.88(5/8)
	Drainage	mm(inch)	DN20(R3/4)	DN20(R3/4)	DN20(R3/4)	DN20(R3/4)	DN20(R3/4)	DN20(R3/4)
Stuffing Quantity	20/40/40H	unit	136/280/315	136/280/315	136/280/315	136/280/315	96/200/225	96/200/225

### Specification-60Hz

Model	Indoor		KRVNE30H-2R1A	KRVNE34H-2R1A	KRVNE38H-2R1A	KRVNE43H-2R1A	KRVNE48H-2R1A
Capacity	Cooling	kW	9.0	10.0	11.2	12.5	14.0
		kBtu/h	30.7	34.1	38.2	42.7	47.8
	Heating	kW	11.0	12.0	12.8	13.3	15.0
		kBtu/h	37.5	40.9	43.7	45.4	51.2
Electric Data	Power Supply	V~,Hz,Ph	220-240,60,1	220-240,60,1	220-240,60,1	220-240,60,1	220-240,60,1
	Rated Power	W	168	168	252	252	252
Performance	Air Flow Volume(Hi/Mid/Low)	m³/h	1500/1200/1050	1500/1200/1050	1800/1440/1260	1800/1440/1260	1800/1440/1260
	Noise Level(Hi/Mid/Low)	dB(A)	47/44/41	47/44/41	48/45/42	48/45/42	48/45/42
Dimension (WxDxH)	Net	mm	1280 × 660 × 205	1280 × 660 × 205	1631 × 660 × 205	1631 × 660 × 205	1631 × 660 × 205
	Packing	mm	1360 × 720 × 290	1360 × 720 × 290	1710 × 720 × 290	1710 × 720 × 290	1710 × 720 × 290
Weight	Net/Gross	kg	35/39	35/39	45/51	45/51	45/51
	Liquid Side	mm(inch)	9.52(3/8)	9.52(3/8)	9.52(3/8)	9.52(3/8)	9.52(3/8)
Pipe Diameter	Gas Side	mm(inch)	15.88(5/8)	15.88(5/8)	15.88(5/8)	15.88(5/8)	15.88(5/8)
	Drainage	mm(inch)	DN20(R3/4)	DN20(R3/4)	DN20(R3/4)	DN20(R3/4)	DN20(R3/4)
Stuffing Quantity	20/40/40H	unit	96/200/225	96/200/225	80/168/189	80/168/189	80/168/189

Notes:

1.Cooling Capacity: Indoor temperature 27°C DB/19°C WB; Outdoor temperature: 35°C DB/24°C WB.

2.Heating Capacity: Indoor temperature 20°C DB; Outdoor temperature: 7°C DB/6°C WB.

3.Piping Length: Equivalent piping length: 7.5m, level difference: 0m.

4.Sound level is measured at 1.4m below the unit.

5.The above designs and specifications are subject to change without prior notice. Final specifications please refer to technical specification provided by sales representative.



## Wall-mounted



### FEATURES



Remote Control



Intelligent Defrosting



Sleep Mode



Fast Cooling/Heating



Anti-Cold-Air



Digital Tube Display



Wired Control



Central Control

■ optional ■ standard







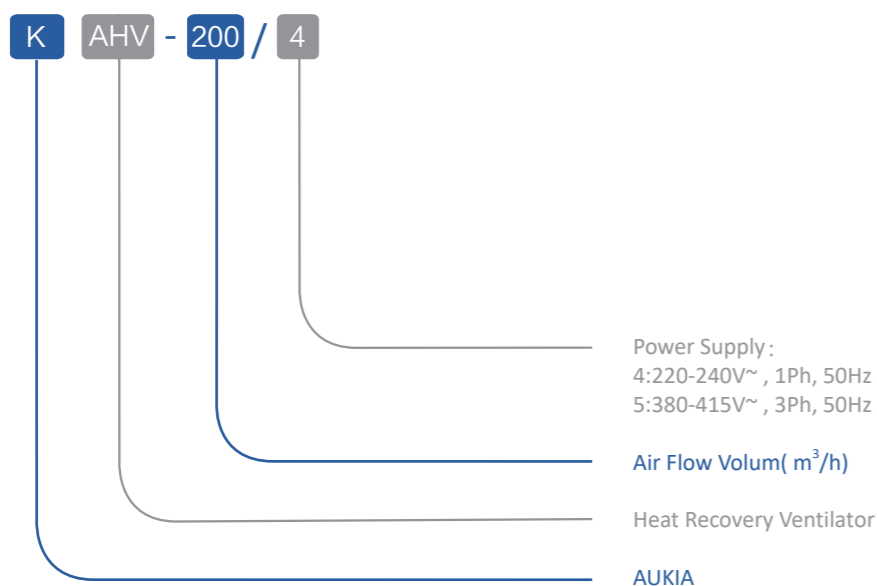



# HRV-Heat Recovery Ventilator

## Nomenclature



## FEATURES

■ optional ■ standard

-  Remote Control
-  Intelligent Defrosting
-  Sleep Mode
-  Fast Cooling/Heating
-  Anti-Cold-Air
-  Digital Tube Display
-  Wired Control
-  Central Control

# HRV-Heat Recovery Ventilator

Adopt Centrifugal Fan With Lower Power Consumption And Longer Air Supply Distance; Easy Control, Friendly Operation.

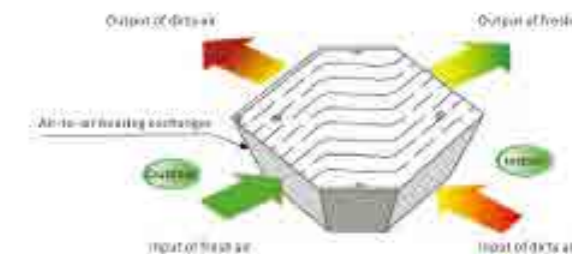

All units are equipped with 3-speed fan mode, adjusting the air flow rate in accordance with the ceiling height. Innovative centrifugal fan provides larger air volume but lower noise, making the air supply more quietly and smoothly.

## High Efficiency

Adopt high quality paper-core heat exchanger, less air resistance. Fresh-air can get a great deal of energy from exhaust air.

## Low Noise

Adopt sound absorption material, quiet operation.

## HRV (Heat Recovery Ventilator) Adopt High

Efficiency Heat Exchanged Core. The heat exchanged core forming by special paper that be processed with chemical treatment, which could create the optimum result in temperature, humidity and cooling recovery.

## Energy Saving

Fresh air and exhaust air are crossed through the heat exchanger. Temperature and humidity exchange happened in the heat recovery ventilator. Fresh-air can get a great deal of energy from exhaust air.

## Different Modes For Your Choice

**Exhausting mode (Hi/Mid/Low fan speed can be chosen)**

**Air supply mode (Hi/Mid/Low fan speed can be chosen)**

**By pass mode (Hi/Mid/Low fan speed can be chosen)**

In this mode, there is no heat exchanging happened, which is more energy saving.

For example:

If outdoor temperature is lower than indoor, we don't need heat exchanging, but we need fresh air. We can choose by pass mode.

Remark: this mode is only available for HRV-200~1000.

**Heat exchanging mode (Hi/Mid/Low fan speed can be chosen)**

In this mode, supply air flow=exhaust air flow.

**Auto mode**

In this mode, the unit will run at heat exchange mode or by pass mode judged by outdoor temperature and indoor temperature with low speed air flow.

Compact Design, Easily Installation & Maintenance.



# HRV

## Specification-HRV

Model		KHRV-200/4	KHRV-300/4	KHRV-400/4	KHRV-500/4	KHRV-600/4	KHRV-800/4	KHRV-1000/4	
Volume	m <sup>3</sup> /h	200	300	400	500	600	800	1000	
	CFM	118	176	235	294	353	471	588	
External static pressure	Pa	75	75	100	110	110	120	120	
Electric Data	Power Supply	V~, Hz, Ph	220-240,50,1	220-240,50,1	220-240,50,1	220-240,50,1	220-240,50,1	220-240,50,1	
	Power Input	W	65	130	200	220	220	410	510
Cooling	Temp. Efficiency	%	62	63	61	60	63	62	
	Enthalpy Efficiency	%	56	56	56	54	55	52	
Heating	Temp. Efficiency	%	72	71.5	71	70	72	71	
	Enthalpy Efficiency	%	58	56	56	56	62	62	
Noise Level	dB(A)	34	34.8	36	36	37.5	38.5	41.5	
Net Dimension(WxDxH)	mm	660x580x264	744x599x270	744x804x270	828x904x264	824x904x270	1116x884x388	1116x1134x388	
Flange	mm	ϕ 144	ϕ 144	ϕ 144	ϕ 194	ϕ 194	ϕ 243	ϕ 243	
Net Weight	kg	23	27	33	46	48	63	79	
Stuffing Quantity	20/40/40H	unit	280/568/710	216/456/513	168/344/387	112/244/280	112/224/252	72/156/156	60/120/120

## Specification-HRV

Model		KHRV-1500/5	KHRV-2000/5	KHRV-2500/5	KHRV-3000/5	KHRV-4000/5	KHRV-5000/5	
Volume	m <sup>3</sup> /h	1500	2000	2500	3000	4000	5000	
	CFM	882	1176	1471	1765	2353	2941	
External static pressure	Pa	160	170	180	200	220	240	
Electric Data	Power Supply	V~, Hz, Ph	380-415,50,3	380-415,50,3	380-415,50,3	380-415,50,3	380-415,50,3	
	Power Input	W	1000	1200	2000	2100	2400	3000
Cooling	Temp. Efficiency	%	62	60	62	64	64	64
	Enthalpy Efficiency	%	51	52	50	55	51	55
Heating	Temp. Efficiency	%	70.5	70	70	72	71	72
	Enthalpy Efficiency	%	62	63	63	64	64	65
Noise Level	dB(A)	51	53	55	57	64	64	
Net Dimension(WxDxH)	mm	1500 × 1200 × 540	1500 × 1200 × 540	1500 × 1200 × 540	1500 × 1200 × 540	1620 × 1330 × 990	1620 × 1330 × 990	
Flange	mm	320x300	320x300	320x300	320x300	323x253	500x690	
Net Weight	kg	173	186	200	270	300	320	
Stuffing Quantity	20/40/40H	unit	20/40/40	20/40/40	20/40/40	8/18/18	8/18/18	

## Branch Pipe

Model	Appearance	Dimension	
		Gas side joints	Liquid side joints
AFG-00B			
AFG-12B			
AFG-24B			
AFG-34B			
AFG-50B			
AFG-64B			

Model	Packing Dimension(mm)	Gross Weight(kg)	Description
AFG-00B	300x95x40	0.31/0.35	A* < 8HP
AFG-12B	330x100x40	0.44/0.49	8HP ≤ A* ≤ 12HP
AFG-24B	370x115x45	0.71/0.77	12HP < A* ≤ 24HP
AFG-34B	440x140x50	1.11/1.20	24HP < A* ≤ 34HP
AFG-50B	480x160x65	1.65/1.76	34HP < A* ≤ 50HP
AFG-64B	480x160x65	1.88/1.98	50HP < A* ≤ 80HP

A\*: The total capacity of indoor units which is connected to this branch joint

# Nomenclature

## Chiller

K AS T 68 C - 5 R3 E

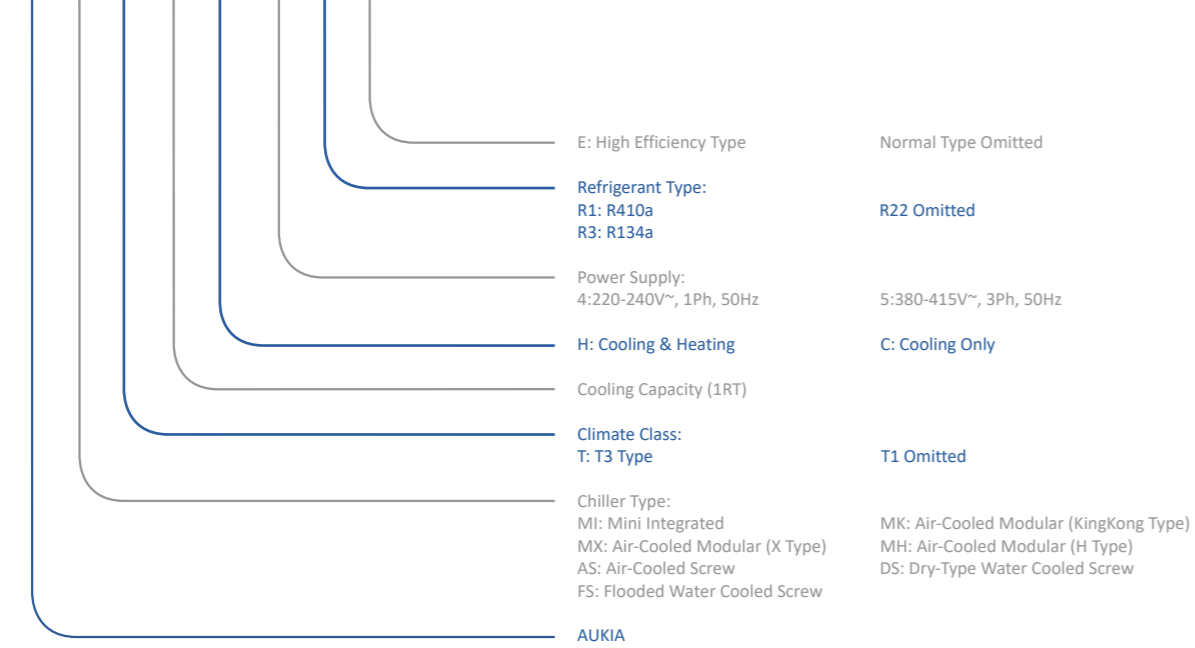

## FCU

K FU 200 NH L - 4 B A

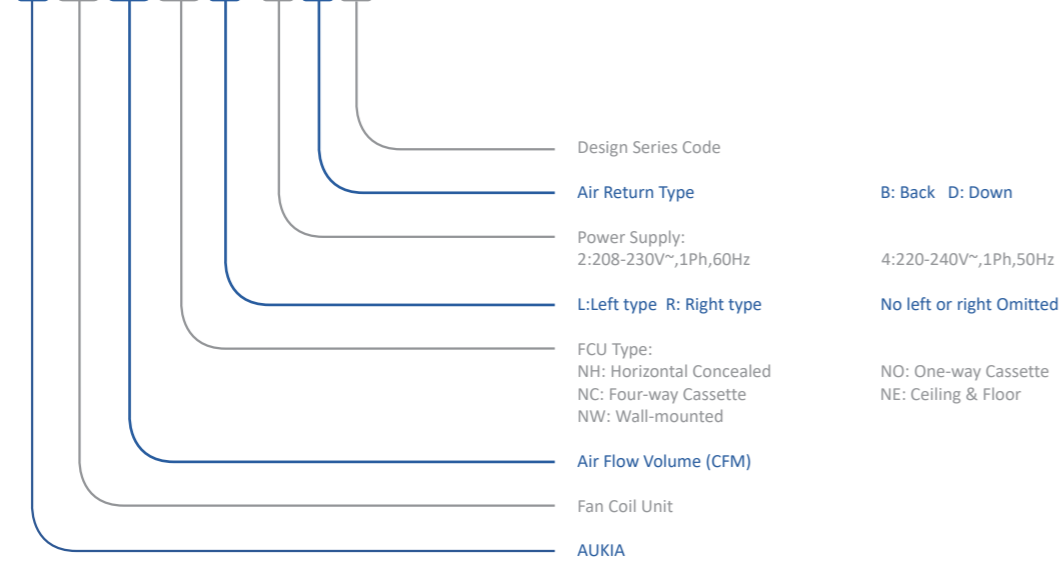

## H Type Modular Chiller

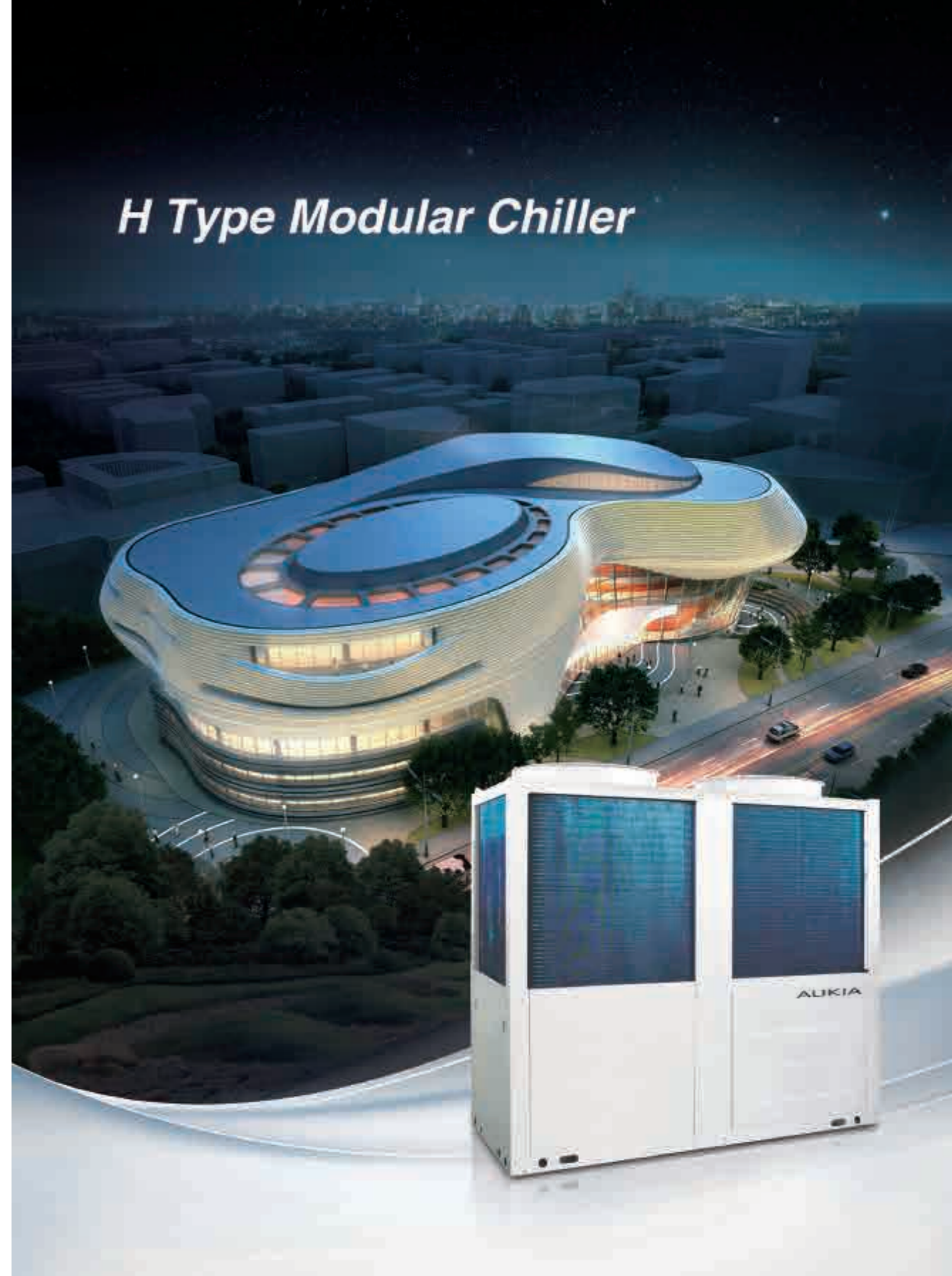

# H Type Modular Chiller



XK-04



## High Efficient Round Heat Exchanger

We selected high slimmer inner grooved copper tube in the modular chiller, which has improved more than 10% heat exchanging efficiency than the normal one.

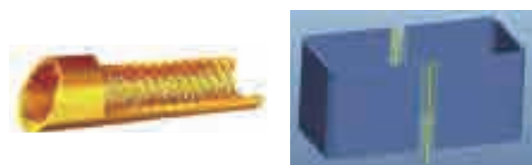

## Back-Up Running

As one of outdoor units breaks down, the rest of outdoor units in the same refrigerant system can turn to operation urgently.



## Modular Design

Any modular can be the main module in one combination. Different standard models can be flexibly combined together depend on user' requirement, and the maximum number of combinations system can reach 16.



## Compact Design

H type design takes less space.

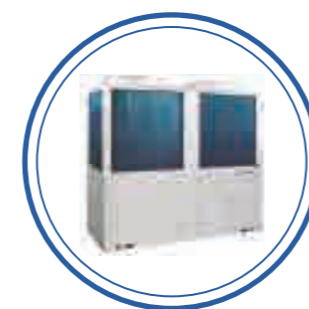
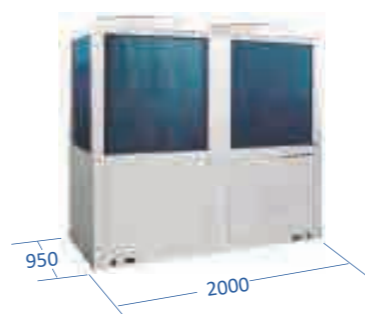

# H Type Modular Chiller

## Specification-R410a 50Hz

Model name	Outdoor		KMH18H-5R1	KMH37H-5R1	KMH18H-5R1A
Capacity	Cooling/Heating	Btu/h	222000/242000	443600/484500	222000/242000
		kW	65/71	130/142	65/71
Electric Data	Power Supply	V-,Hz,Ph	380-415,50,3	380-415,50,3	380-415,50,3
	Cooling/Heating Power Input	kW	19.2/21.5	38.4/40.5	19.2/21.5
	Cooling/Heating Current	A	36.3/38.9	72.6/73.3	36.3/38.9
Compressor	Type		Hermetic Scroll	Hermetic Scroll	Rolling rotor
	Quantity	Pieces	2	2	4
Refrigerant Type			R410a	R410a	R410a
Air Side Heat Exchanger	Type		High efficiency heat transfer tube series aluminum fin	High efficiency heat transfer tube series aluminum fin	High efficiency heat transfer tube series aluminum fin
	Fan Quantity	Pieces	2	2	2
	Air Flow Volume	m <sup>3</sup> /h	13500 × 2	27000 × 2	13500 × 2
Water Side Heat Exchanger	Type		High-efficiency tube in tube heat exchanger	High-efficiency tube in tube heat exchanger	High-efficiency tube in tube heat exchanger
	Water Resistance	kPa	45	55	45
	Water Flow Volume	m <sup>3</sup> /h	11.2	22.4	11.2
	Max. Pressure	MPa	1	1	1
Dimension (WxDxH)	Net	mm	2000 × 950 × 1880	2200 × 1100 × 2270	2000 × 950 × 1880
	Packing	mm	2050 × 1000 × 1980	2250 × 1150 × 2370	2050 × 1000 × 1980
Weight	Net/Gross	kg	580/595	945/965	625/640
Inlet/Outlet Water Pipe		mm	DN50	DN65	DN50
Noise		dB(A)	≤ 65	≤ 68	≤ 65
Safety Protection	High-efficiency shell and tube heat exchanger High/low pressure protection, lack/reverse phase protection, water lack protection, water flow protection, anti-freezing protection, etc.				

Note:  
 All the above data is tested base on the following working condition:  
 1. Rated cooling working condition: water flow 0.172 m<sup>3</sup>/(h · kW), chilled water inlet/outlet temperature 12°C/7°C, ambient temperature 35°C;  
 2. Rated heating working condition: water flow 0.172 m<sup>3</sup>/(h · kW), hot water inlet/outlet temperature 40°C/45°C, ambient temperature 7°C, WB temperature 6°C;  
 3. Keep 1m away from the chiller front and 1.5m high when detecting noise level, environmental noise is lower than 30db(A);  
 As a part of continuous product improvement, we reserves the right to change specifications without notice.

## Cooling Capacity And Power Under Different Ambient And Water Outlet Temperature

### KMH18H-5R1 Cooling capacity and power in cooling mode

Chilled water outlet temperature (°C)	Ambient Temperature(°C)											
	25		30		35		40		47		49	
	Cooling capacity kW	Power consumption kW	Cooling capacity kW	Power consumption kW	Cooling capacity kW	Power consumption kW	Cooling capacity kW	Power consumption kW	Cooling capacity kW	Power consumption kW	Cooling capacity kW	Power consumption kW
5	66.53	15.42	63.18	16.80	60.00	18.32	56.98	19.97	54.11	21.76	53.29	22.27
7	69.85	15.57	66.34	16.97	65.00	19.20	59.83	20.37	56.82	21.98	56.14	22.66
10	73.35	15.73	69.66	17.14	66.15	19.84	62.82	20.49	59.66	22.53	59.13	22.78
13	77.02	15.88	73.14	17.31	69.46	20.02	65.96	20.75	62.64	22.82	58.95	23.06

### KMH37H-5R1 Cooling capacity and power in cooling mode

Chilled water outlet temperature (°C)	Ambient Temperature(°C)											
	25		30		35		40		47		49	
	Cooling capacity kW	Power consumption kW	Cooling capacity kW	Power consumption kW	Cooling capacity kW	Power consumption kW	Cooling capacity kW	Power consumption kW	Cooling capacity kW	Power consumption kW	Cooling capacity kW	Power consumption kW
5	133.06	30.83	126.36	33.61	123.00	36.63	113.96	39.93	108.22	43.52	106.58	44.01
7	139.71	31.14	132.68	33.94	130.00	38.40	119.66	40.33	113.64	43.96	112.28	44.95
10	146.70	31.45	139.31	34.28	132.30	38.57	125.64	40.73	119.32	44.40	118.26	45.36
13	154.03	31.77	146.28	34.63	138.92	39.74	131.92	41.14	125.28	44.84	125.54	45.77

## Heating capacity And Power Under Different Ambient And Water Outlet Temperature

### KMH18H-5R1 Heating capacity and power in heating mode (RH is 90%)

Hot water outlet temperature (°C)	Outdoor DB temperature(°C)									
	-12		-5		0		7		12	
	Heating capacity kW	Power consumption kW	Heating capacity kW	Power consumption kW	Heating capacity kW	Power consumption kW	Heating capacity kW	Power consumption kW	Heating capacity kW	Power consumption kW
35	39.38	17.17	48.62	17.50	60.03	17.84	73.20	18.18	86.38	18.53
40	38.24	18.58	47.20	18.94	58.28	19.30	72.07	19.68	83.86	20.05
45	---	---	45.83	20.50	56.58	20.89	71.00	21.50	81.42	21.71
50	---	---	44.49	22.19	54.93	22.62	66.99	23.07	79.05	23.51

### KMH37H-5R1 Heating capacity and power in heating mode (RH is 90%)

Hot water outlet temperature (°C)	Outdoor DB temperature(°C)									
	-12		-5		0		7		12	
	Heating capacity kW	Power consumption kW	Heating capacity kW	Power consumption kW	Heating capacity kW	Power consumption kW	Heating capacity kW	Power consumption kW	Heating capacity kW	Power consumption kW
35	79.34	31.42	97.95	32.08	120.92	33.76	147.47	34.45	174.01	35.14
40	77.03	34.24	95.09	35.96	117.40	36.70	143.17	37.44	168.94	38.19
45	---	---	92.32	37.59	113.98	38.89	140.00	40.50	164.02	41.51
50	---	---	89.63	40.89	110.66	41.35	134.95	43.24	159.24	45.12

## X Type Modular Chiller

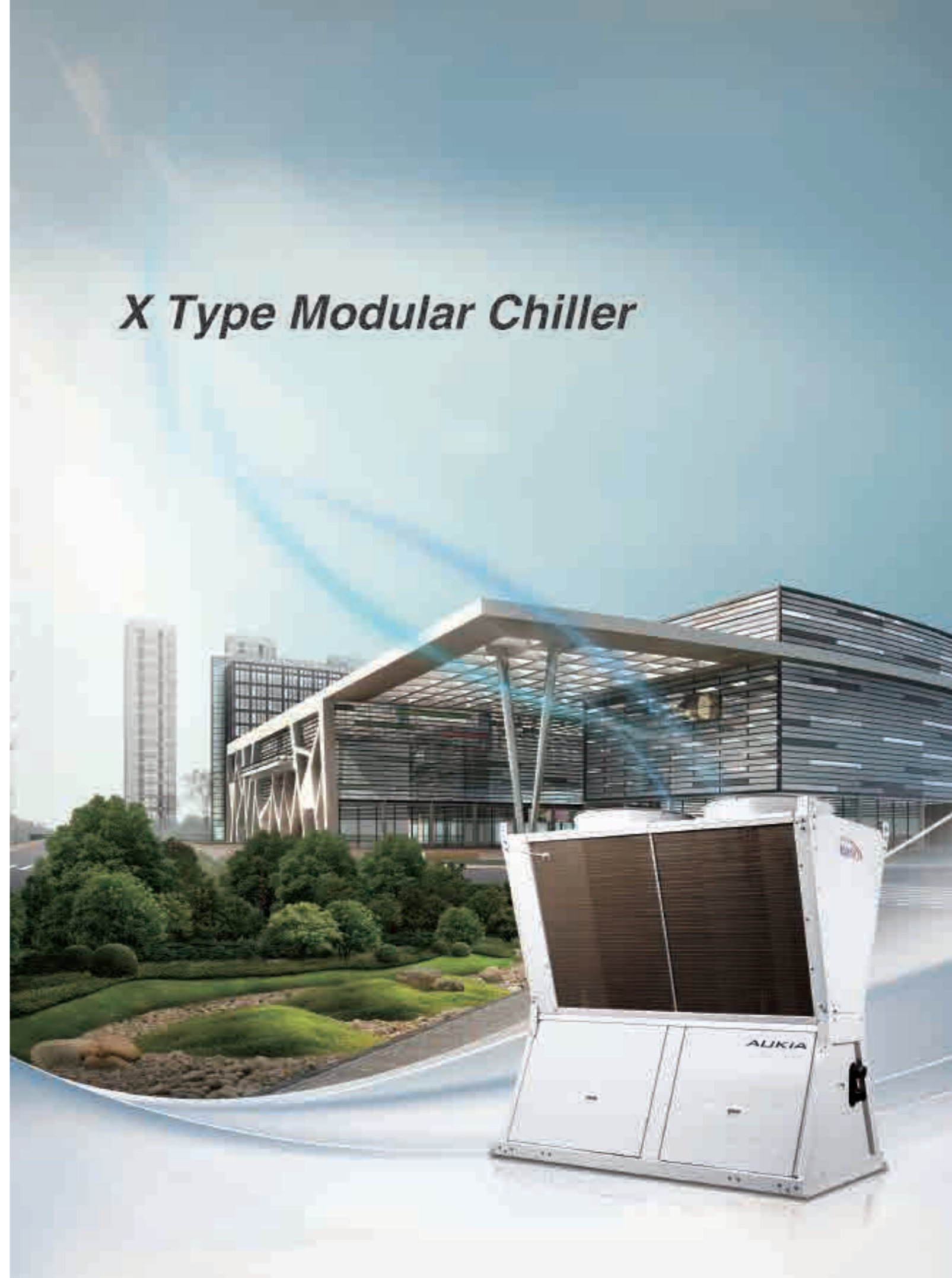



# X Type Modular Chiller



XK-04

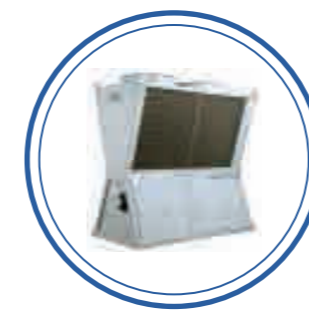

## X Type Modular Chiller

### Specification-R410a 50Hz

Model name	Outdoor		KMX9H-5R1	KMX18H-5R1
Capacity	Cooling/Heating	Btu/h	100000/110000	222000/245500
		kW	30/33	65/70
Electric Data	Power Supply	V-, Hz, Ph	380-415, 50, 3	380-415, 50, 3
	Cooling/Heating Power Input	kW	8.80/10.20	19.10/20.25
	Cooling/Heating Current	A	15.7/18.2	35.2/38.7
Compressor	Type		Hermetic scroll	Hermetic scroll
	Quantity	Pieces	1	2
Refrigerant Type			R410a	R410a
	Type		High-efficient fin heat exchanger	High-efficient fin heat exchanger
Air Side Heat Exchanger	Fan Quantity	Pieces	1	2
	Air Flow Volume	m <sup>3</sup> /h	13500 × 2	13500 × 2
Water Side Heat Exchanger	Type		High-efficiency tube in tube heat exchanger	High-efficiency shell and tube heat exchanger
	Water Resistance	kPa	45	57
	Water Flow Volume	m <sup>3</sup> /h	5.2	11.2
	Max. Pressure	MPa	1	1
Dimension (WxDxH)	Net	mm	1580 × 1020 × 2060	2090 × 1020 × 2060
	Packing	mm	1680 × 1120 × 2160	2150 × 1080 × 2170
Weight	Net/Gross	kg	350/420	650/700
Inlet/Outlet Water Pipe		mm	DN40	DN50
Noise		dB(A)	≤ 65	≤ 69
Safety Protection	High/low pressure protection, lack/reverse phase protection, water lack protection, water flow protection, anti-freezing protection, etc.			

### Seamless Combination

Seamless combination can be only achieved on flexible connection. The installation is very convenient and the space saves is 50% more than the normal ones. This saves the installation investment greatly. X-structural modules combination can greatly improve air flow volume, air speed uniformity, and the efficiency of air side heat exchanger because of the wind-tunnel effect.

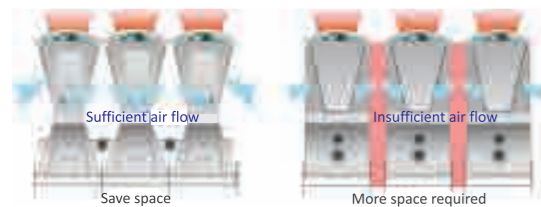

### IFalling-film Condensing Technology

After spraying, the condensing temperature will decrease more than 10%, the EER will increase 15%. The maximum operating ambient temperature can increase to 52°C from 47°C. The working condition of the compressor is improved depend on the decline of condensing temperature, so it can prolong the service life of the compressor.

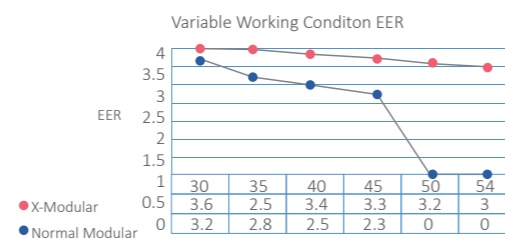

### Balanced Control Technology

According to record system load and operation time of each module, the system can get the balanced load time between each module to keep the whole system operate in a continuous stable state and ensure its reliability and lifetime.

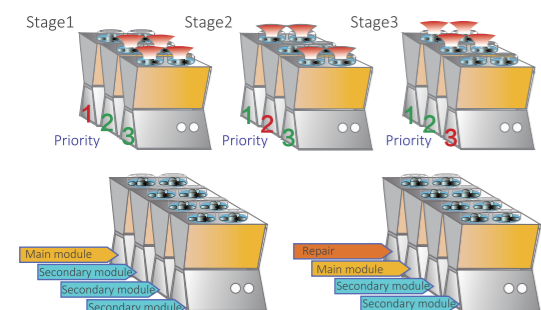

### Modular Design

Any modular can be assigned as the main module in one combination. Different standard models can be flexibly combined together depend on users' requirement, and the maximum number of combinations system can reach 16.



Note:  
 All the above data is tested base on the following working condition:  
 1. Rated cooling working condition: water flow 0.172 m<sup>3</sup>/(h · kW), chilled water inlet/outlet temperature 12°C/7°C, ambient temperature 35°C;  
 2. Rated heating working condition: water flow 0.172 m<sup>3</sup>/(h · kW), hot water inlet/outlet temperature 40°C/45°C, ambient temperature 7°C, WB temperature 6°C;  
 3. Keep 1m away from the chiller front and 1.5m high when detecting noise level, environmental noise is lower than 30db(A);  
 As a part of continuous product improvement, we reserves the right to change specifications without notice.

## Cooling Capacity And Power Under Different Ambient And Water Outlet Temperature

### KMX9H-5R1 cooling capacity and power in cooling mode

Chilled water outlet temperature (°C)	Ambient Temperature(°C)											
	25		30		35		40		47		49	
	Cooling capacity kW	Power consumption kW	Cooling capacity kW	Power consumption kW	Cooling capacity kW	Power consumption kW	Cooling capacity kW	Power consumption kW	Cooling capacity kW	Power consumption kW	Cooling capacity kW	Power consumption kW
5	33.68	7.75	31.62	8.41	30.19	9.13	28.36	9.93	27.26	10.91	26.85	11.02
7	34.95	7.84	33.41	8.54	30.00	8.80	29.92	10.09	28.46	10.99	28.14	11.40
10	37.13	7.94	35.46	8.61	33.38	9.77	31.64	10.21	29.74	11.09	29.48	11.81
13	38.43	8.03	36.40	8.75	34.66	10.07	33.07	10.32	31.24	11.20	30.80	12.24

### KMX18H-5R1 cooling capacity and power in cooling mode

Chilled water outlet temperature (°C)	Ambient Temperature(°C)											
	25		30		35		40		47		49	
	Cooling capacity kW	Power consumption kW	Cooling capacity kW	Power consumption kW	Cooling capacity kW	Power consumption kW	Cooling capacity kW	Power consumption kW	Cooling capacity kW	Power consumption kW	Cooling capacity kW	Power consumption kW
5	67.35	15.49	63.24	16.82	60.38	18.25	56.72	19.85	54.52	21.82	53.32	22.52
7	69.89	15.67	66.81	17.07	65.00	19.10	59.83	20.17	56.91	21.97	55.65	22.92
10	74.26	15.88	70.91	17.21	66.75	19.54	63.27	20.41	59.47	22.17	58.76	23.31
13	76.85	16.06	72.79	17.49	69.31	20.13	66.14	20.64	62.47	22.40	61.06	23.66

## Heating capacity And Power Under Different Ambient And Water Outlet Temperature

### KMX9H-5R1 heating capacity and power in heating mode (RH is 90%)

Hot water outlet temperature (°C)	Outdoor DB temperature(°C)									
	-12		-5		0		7		12	
	Heating capacity kW	Power consumption kW	Heating capacity kW	Power consumption kW	Heating capacity kW	Power consumption kW	Heating capacity kW	Power consumption kW	Heating capacity kW	Power consumption kW
35	19.79	8.14	24.36	8.33	30.11	8.39	36.71	8.62	43.28	19.79
40	19.22	8.72	23.73	8.92	29.22	9.10	35.92	9.39	42.01	19.22
45	---	---	22.89	9.76	28.28	9.89	33.00	10.20	40.75	10.34
50	---	---	22.17	10.61	27.46	10.79	33.50	11.06	39.62	11.24

### KMX18H-5R1 heating capacity and power in heating mode (RH is 90%)

Hot water outlet temperature (°C)	Outdoor DB temperature(°C)									
	-12		-5		0		7		12	
	Heating capacity kW	Power consumption kW	Heating capacity kW	Power consumption kW	Heating capacity kW	Power consumption kW	Heating capacity kW	Power consumption kW	Heating capacity kW	Power consumption kW
35	39.57	16.28	48.71	16.66	60.21	16.77	73.42	17.23	86.55	17.72
40	17.43	47.45	17.84	58.43	18.20	71.84	18.77	84.02	18.98	17.43
45	---	45.77	19.52	56.55	19.78	70.00	20.25	81.49	20.67	---
50	---	44.33	21.21	54.92	21.57	66.99	22.11	79.24	22.47	---

Notes: As a part of continuous product improvement, AUKIA reserves the right to change specifications and design without prior notice. The specification subjects to the nameplate of the chiller.

**Hydraulic module**



# Hydraulic Module



## Backup Function

Two pumps built-in, one of them is backup. It can be automatically switched between two pumps in failure.



## Compact Design

The electric control cabinet can be separated from the unit to install, more convenient operating for user without nearby the unit.



## Easy Installation And Maintenance

The unit can be installed indoor and outdoor, suit for different customer's requirement. There are screw connecting and flange connecting, convenient for connecting.

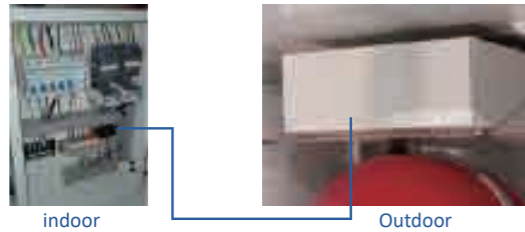

## Save The Installation Space And Cost

Integrated design, covering area is too less. Intelligent control, it saves energy more than 30% than traditional. For air-cooled modular chiller, it's no need of expansion tank.



## Hydranic Module

Model name			ACHM7/D-22	ACHM14/D-25	ACHM30/D-27
Capacity	kW		26 ~ 35	46 ~ 65	116 ~ 150
Electric Data	Power Supply	V~, Hz, Ph	380V/3N/50Hz	380V/3N/50Hz	380V/3N/50Hz
	Power Input	kW	1.1	1.75	4.5
Water Side	Head	m	22	25	27
	Water Flow Volume	m <sup>3</sup> /h	7	14	30
	Pump Quantity	Pieces	2	2	2
Dimension (W × D × H)	Net	mm	1165 × 610 × 770	1200 × 700 × 820	1590 × 930 × 990
	Packing	mm	1180 × 670 × 880	1230 × 760 × 930	1600 × 1000 × 1100
Weight	Net/Gross	kg	110/120	130/142	310/32
	Pipe diameter (inlet & outlet)	mm(inch)	DN40(1-1/2")	DN50(2")	DN65(2-1/2")

## One-way Cassette Fan Coil Unit



# One-way Cassette Fan Coil Unit

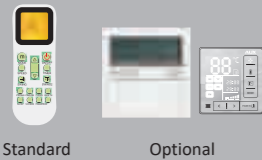

The Built-In Drainage Water Pump Can Lift Condensing Water Up To 700mm High From Drainage Pan.

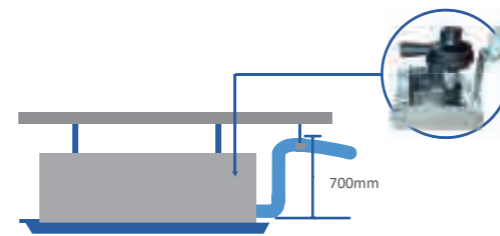

Special Design With Excellent Heat Insulation Effect To Ensure The Casing Hango Condensation.

Long Term Air Filter: The Wash Period Is Two Times Longer Than Normal Filter And Maintenance Is Free

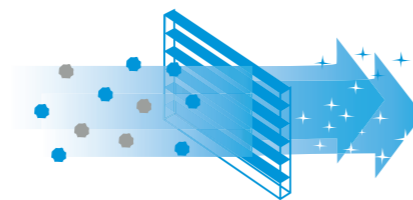

Fresh Air Inlet Can Intake Outdoor Fresh To Improve Indoor Air Quality.

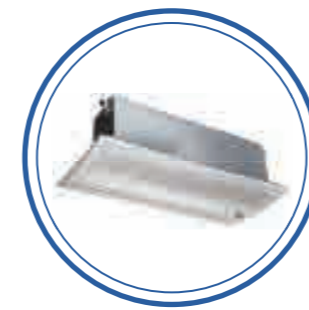

## One-way Cassette FCU

### Specification-50Hz

Model		KFU200NO-4	KFU300NO-4	KFU400NO-4	KFU500NO-4
Air Volume(H/M/L)	CFM	200/165/106	300/224/153	400/303/200	500/388/253
	m <sup>3</sup> /h	340/280/180	510/380/260	680/515/340	850/660/430
Cooling Capacity	H/M/L Speed	W	1800/1500/1390	2700/2460/2057	3600/3000/2479
	W				4500/3715/2920
Heating Capacity	H/M/L Speed	W	2700/1950/1290	4050/2770/1774	5400/3935/2800
	W				6750/4900/3505
Noise Level		dB(A)	≤ 37	≤ 39	≤ 41
					≤ 43
Fan Motor	Fan Quantity		1	1	1
	Motor Quantity		1	1	1
	Power Input	W	37	52	62
Water Flow Volume	m <sup>3</sup> /h	0.31	0.46	0.62	0.77
Hydraulic Resistance	kPa	10.8	10.8	20	20
Max.Working pressure	MPa	1.6	1.6	1.6	1.6
Dimension (WxDxH)	Net(Body)	mm	850x400x235	850x400x235	850x400x235
	Packing(Body)	mm	1040x478x310	1040x478x310	1040x478x310
	Net(Panel)	mm	1040x470x18	1040x470x18	1040x470x18
	Packing(Panel)	mm	1055x515x175	1055x515x175	1055x515x175
Weight	Net/Gross(Body)	kg	22/26	22/26	23/27
	Net/Gross(Panel)	kg	4/6	4/6	4/6
Inlet/Outlet Water Pipe				Rc3/4" (DN20)	
Drain Pipe				R3/4" (DN20)	
Stuffing Quantity(20/40/40H)		117/245/273	117/245/273	117/245/273	117/245/273

Note:  
 1. Cooling capacity test conditions: Air inlet Temp. : 27°C DB/19.5°C WB, Water inlet/outlet Temp. : 7°C/12°C;  
 2. Heating capacity test conditions: Air inlet Temp. : 21°C DB, Water inlet Temp. : 60°C;  
 3. Noise level is tested in full-anechoic room.

# Four-way Cassette Fan Coil Unit



Standard



Optional



## Four-way Cassette Fan Coil Unit



### Built-In Water Drainage Pump

The built-in pump can lift condensing water up to 1200mm high from the drainage pan.

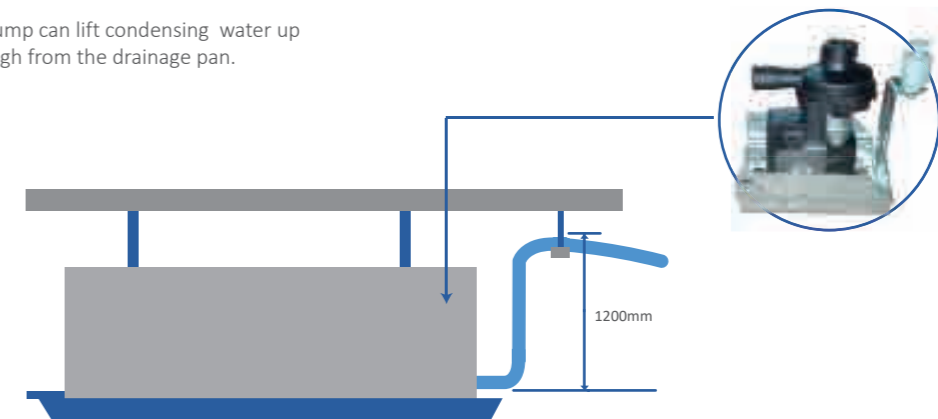

### Fresh Air Intake

Fresh air makes indoor air healthy and comfortable.



Fresh air intake

### Optimized Electric Box

Better fire-proof and easy to maintenance.

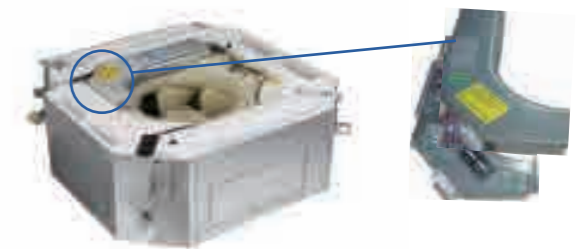

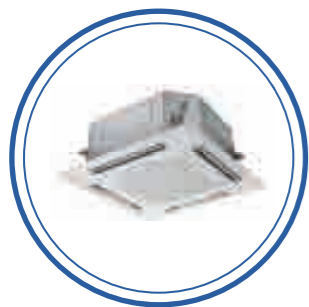

## Four-way Cassette FCU

### Specification-50Hz

Model		KFU300NC-4	KFU400NC-4	KFU500NC-4	KFU600NC-4
Air Volume(H/M/L)	CFM	300/225/150	400/300/200	500/375/250	600/450/300
	m <sup>3</sup> /h	510/382/255	680/510/340	850/638/425	1020/765/510
Cooling Capacity	H/M/L Speed	W	2712/2305/1763	3618/3075/2352	4514/3837/2934
	W	4070/3460/2646	5418/4605/3522	6767/5752/4399	8115/6898/5275
Heating Capacity	H/M/L Speed	W	4070/3460/2646	5418/4605/3522	6767/5752/4399
	W	4070/3460/2646	5418/4605/3522	6767/5752/4399	8115/6898/5275
Noise Level	dB(A)	≤ 39	≤ 40	≤ 42	≤ 45
	Fan Quantity	1	1	1	1
Fan Motor	Motor Quantity	1	1	1	1
	Power Input	W	50	57	67
	W	50	57	67	96
Water Flow Volume	m <sup>3</sup> /h	0.62	0.70	0.94	1.15
Hydraulic Resistance	kPa	26	27	29	31
Max.Working pressure	MPa	1.6	1.6	1.6	1.6
Dimension (WxDxH)	Net(Body)	mm	615 × 615 × 263	615 × 615 × 263	615 × 615 × 263
	Packing(Body)	mm	700 × 700 × 330	700 × 700 × 330	700 × 700 × 330
	Net(Panel)	mm	650 × 650 × 55	650 × 650 × 55	650 × 650 × 55
	Packing(Panel)	mm	710 × 710 × 80	710 × 710 × 80	710 × 710 × 80
Weight	Net/Gross(Body)	kg	20/21.5	20/21.5	21/22.5
	Net/Gross(Panel)	kg	3/5	3/5	3/5
Inlet/Outlet Water Pipe		Rc3/4" (DN20)			
Drain Pipe		R3/4" (DN20)			
Stuffing Quantity(20/40/40H)		140/312/354	140/312/354	140/312/354	78/168/184

### Specification-50Hz

Model		KFU800NC-4	KFU1000NC-4	KFU1200NC-4	KFU1400NC-4
Air Volume(H/M/L)	CFM	800/600/400	1000/750/500	1200/900/600	1400/1050/700
	m <sup>3</sup> /h	1360/1020/680	1700/1275/850	2040/1530/1020	2380/1785/1190
Cooling Capacity	H/M/L Speed	W	7210/6129/4687	9018/7665/5862	10810/9189/7027
	W	10807/9186/7025	13512/11485/8783	16205/13774/10553	18901/16066/12286
Heating Capacity	H/M/L Speed	W	10807/9186/7025	13512/11485/8783	16205/13774/10553
	W	10807/9186/7025	13512/11485/8783	16205/13774/10553	18901/16066/12286
Noise Level	dB(A)	≤ 46	≤ 48	≤ 50	≤ 52
	Fan Quantity	1	1	1	1
Fan Motor	Motor Quantity	1	1	1	1
	Power Input	W	131	145	186
	W	131	145	186	225
Water Flow Volume	m <sup>3</sup> /h	1.4	1.68	1.82	2.25
Hydraulic Resistance	kPa	34	36	39	42
Max.Working pressure	MPa	1.6	1.6	1.6	1.6
Dimension (WxDxH)	Net(Body)	mm	835 × 835 × 250	835 × 835 × 290	835 × 835 × 290
	Packing(Body)	mm	910 × 910 × 310	910 × 910 × 350	910 × 910 × 350
	Net(Panel)	mm	950×950×55	950×950×55	950×950×55
	Packing(Panel)	mm	1000×1000×100	1000×1000×100	1000×1000×100
Weight	Net/Gross(Body)	kg	25.5/29	26.5/31	28/32.5
	Net/Gross(Panel)	kg	5/7	5/7	5/7
Inlet/Outlet Water Pipe		Rc3/4" (DN20)			
Drain Pipe		R3/4" (DN20)			
Stuffing Quantity(20/40/40H)		78/168/184	68/150/170	68/150/170	68/150/170

Note:  
 1. Cooling capacity test conditions: Air inlet Temp. : 27°C DB/19.5°C WB, Water inlet/outlet Temp. : 7°C /12°C ;  
 2. Heating capacity test conditions: Air inlet Temp. : 21°C DB, Water inlet Temp. : 60°C ;  
 3. Noise level is tested in full-anechoic room.

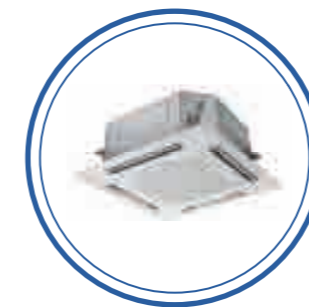

## Four-way Cassette FCU

### Specification-60Hz

Model		KFU300NC-2	KFU400NC-2	KFU500NC-2	KFU600NC-2
Air Volume(H/M/L)	CFM	300/225/150	400/300/200	500/375/250	600/450/300
	m <sup>3</sup> /h	510/382/255	680/510/340	850/638/425	1020/765/510
Cooling Capacity	H/M/L Speed	W	2712/2305/1763	3618/3075/2352	4514/3837/2934
	W	4070/3460/2646	5418/4605/3522	6767/5752/4399	8115/6898/5275
Heating Capacity	H/M/L Speed	W	4070/3460/2646	5418/4605/3522	6767/5752/4399
	W	4070/3460/2646	5418/4605/3522	6767/5752/4399	8115/6898/5275
Noise Level	dB(A)	≤ 39	≤ 40	≤ 42	≤ 45
	Fan Quantity	1	1	1	1
Fan Motor	Motor Quantity	1	1	1	1
	Power Input	W	50	57	67
	W	50	57	67	90
Water Flow Volume	m <sup>3</sup> /h	0.62	0.7	0.94	1.15
Hydraulic Resistance	kPa	26	27	29	31
Max.Working pressure	MPa	1.6	1.6	1.6	1.6
Dimension (WxDxH)	Net(Body)	mm	615 × 615 × 263	615 × 615 × 263	615 × 615 × 263
	Packing(Body)	mm	700 × 700 × 330	700 × 700 × 330	700 × 700 × 330
	Net(Panel)	mm	650 × 650 × 55	650 × 650 × 55	650 × 650 × 55
	Packing(Panel)	mm	710 × 710 × 80	710 × 710 × 80	710 × 710 × 80
Weight	Net/Gross(Body)	kg	20/21.5	20/21.5	23/25.5
	Net/Gross(Panel)	kg	3/5	3/5	3/5
Inlet/Outlet Water Pipe		Rc3/4" (DN20)			
Drain Pipe		R3/4" (DN20)			
Stuffing Quantity(20/40/40H)		140/312/354	140/312/354	140/312/354	78/168/184

### Specification-60Hz

Model		KFU800NC-2	KFU1000NC-2	KFU1200NC-2	KFU1400NC-2
Air Volume(H/M/L)	CFM	800/600/400	1000/750/500	1200/900/600	1400/1050/700
	m <sup>3</sup> /h	1360/1020/680	1700/1275/850	2040/1530/1020	2380/1785/1190
Cooling Capacity	H/M/L Speed	W	7210/6129/4687	9018/7665/5862	10810/9189/7027
	W	10807/9186/7025	13512/11485/8783	16205/13774/10553	18901/16066/12286
Heating Capacity	H/M/L Speed	W	10807/9186/7025	13512/11485/8783	16205/13774/10553
	W	10807/9186/7025	13512/11485/8783	16205/13774/10553	18901/16066/12286
Noise Level	dB(A)	≤ 46	≤ 48	≤ 50	≤ 52
	Fan Quantity	1	1	1	1
Fan Motor	Motor Quantity	1	1	1	1
	Power Input	W	131	145	186
	W	131	145	186	225
Water Flow Volume	m <sup>3</sup> /h	1.4	1.68	1.82	2.25
Hydraulic Resistance	kPa	34	36	39	42
Max.Working pressure	MPa	1.6	1.6	1.6	1.6
Dimension (WxDxH)	Net(Body)	mm	835 × 835 × 250	835 × 835 × 290	835 × 835 × 290
	Packing(Body)	mm	910 × 910 × 310	910 × 910 × 350	910 × 910 × 350
	Net(Panel)	mm	950×950×55	950×950×55	950×950×55
	Packing(Panel)	mm	1000×1000×100	1000×1000×100	1000×1000×100
Weight	Net/Gross(Body)	kg	25.5/29	26.5/31	28/32.5
	Net/Gross(Panel)	kg	5/7	5/7	5/7
Inlet/Outlet Water Pipe		Rc3/4" (DN20)			
Drain Pipe		R3/4" (DN20)			
Stuffing Quantity(20/40/40H)		78/168/184	68/150/170	68/150/170	68/150/170

Note:  
 1. Cooling capacity test conditions: Air inlet Temp. : 27°C DB/19.5°C WB, Water inlet/outlet Temp. : 7°C /12°C ;  
 2. Heating capacity test conditions: Air inlet Temp. : 21°C DB, Water inlet Temp. : 60°C ;  
 3. Noise level is tested in full-anechoic room.



# Ceiling&Floor Fan Coil unit

## Ceiling&Floor Fan Coil Unit



Standard



Optional



### 4D Air Swing

Vertical and horizontal swing makes air below to every corner of the room.

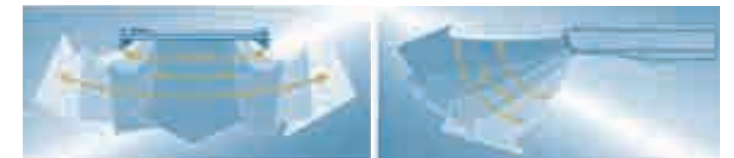

### Ultra Slim Design

The thickness is only 205mm, save installation space.



### Innovative Centrifugal Fan

All units are equipped with 3-speed fan mode, adjusting the air flow rate in accordance with the ceiling height. Innovative centrifugal fan provides larger air volume but lower noise, making the air supply more quietly and smoothly.



### Flexible Installation

Can be vertically installed against the wall or horizontally installed under the ceiling.





## Ceiling&Floor FCU

### Specification-50Hz



Model		KFU400NE-4	KFU500NE-4	KFU600NE-4	KFU800NE-4	KFU1000NE-4
Air Volume(H/M/L)	CFM	400/300/200	500/375/250	600/450/300	800/600/400	1000/750/500
	m <sup>3</sup> /h	680/510/340	850/638/425	1020/765/510	1360/1020/680	1700/1275/850
Cooling Capacity	H/M/L Speed	W	3600/3075/2352	4514/3837/2934	5406/4595/3514	7210/6129/4687
Heating Capacity	H/M/L Speed	W	5418/4605/3522	6767/5752/4399	8115/6898/5275	10807/9186/7025
Noise Level		dB(A)	≤ 42	≤ 45	≤ 48	≤ 48
Fan Motor	Fan Quantity		2	2	3	3
	Motor Quantity		1	1	1	1
	Power Input	W	78	93	117	190
Water Flow Volume		m <sup>3</sup> /h	0.62	0.80	0.98	1.25
Hydraulic Resistance		kPa	16	20	22	30
Max.Working pressure		MPa	1.6	1.6	1.6	1.6
Dimension (WxDxH)	Net	mm	929 × 660 × 205	929 × 660 × 205	1280 × 660 × 205	1280 × 660 × 205
	Packing	mm	1010 × 720 × 290	1010 × 720 × 290	1360 × 720 × 290	1360 × 720 × 290
Net/Gross Weight		kg	24/27	25/28	30/35	33/38
Inlet/Outlet Water Pipe					Rc3/4" (DN20)	
Drain Pipe				R3/4" (DN20)		
Stuffing Quantity(20/40/40H)			136/280/315	136/280/315	96/200/225	96/200/225

### Specification-60Hz



Model		KFU400NE-2	KFU500NE-2	KFU600NE-2	KFU800NE-2	KFU1000NE-2
Air Volume(H/M/L)	CFM	400/300/200	500/375/250	600/450/300	800/600/400	1000/750/500
	m <sup>3</sup> /h	680/510/340	850/638/425	1020/765/510	1360/1020/680	1700/1275/850
Cooling Capacity	H/M/L Speed	W	3600/3075/2352	4514/3837/2934	5406/4595/3514	7210/6129/4687
Heating Capacity	H/M/L Speed	W	5418/4605/3522	6767/5752/4399	8115/6898/5275	10807/9186/7025
Noise Level		dB(A)	≤ 42	≤ 45	≤ 48	≤ 48
Fan Motor	Fan Quantity		2	2	3	3
	Motor Quantity		1	1	1	1
	Power Input	W	78	93	117	190
Water Flow Volume		m <sup>3</sup> /h	0.62	0.80	0.98	1.25
Hydraulic Resistance		kPa	16	20	22	30
Max.Working pressure		MPa	1.6	1.6	1.6	1.6
Dimension (WxDxH)	Net	mm	929 × 660 × 205	929 × 660 × 205	1280 × 660 × 205	1280 × 660 × 205
	Packing	mm	1010 × 720 × 290	1010 × 720 × 290	1360 × 720 × 290	1360 × 720 × 290
Net/Gross Weight		kg	24/27	25/28	30/35	33/38
Inlet/Outlet Water Pipe					Rc3/4" (DN20)	
Drain Pipe				R3/4" (DN20)		
Stuffing Quantity(20/40/40H)			136/280/315	136/280/315	96/200/225	96/200/225

Note:  
 1. Cooling capacity test conditions: Air inlet Temp. : 27°C DB/19.5°C WB, Water inlet/outlet Temp. : 7°C /12°C ;  
 2. Heating capacity test conditions: Air inlet Temp. : 21°C DB, Water inlet Temp. : 60°C ;  
 3. Noise level is tested in full-anechoic room.

## Horizontal Concealed Fan Coil Unit





# Horizontal Concealed Fan Coil Unit



## Die Stamping Drain Pan

The condensate pan is shaped with the mould techniques holistically, no weld seam and weld point.



## Pipe Connecting Direction Free Choice

Left connecting pipe is standard, and right connecting pipe is optional; Left and right drain pipe also can be free choice.



## Adjustable ESP

There are two types ESP can be selected for each mode.



## Return Air Plenum And Filter Are Standard

Back air return and down air return can be free choice, the long term air filter ensures better air quality.

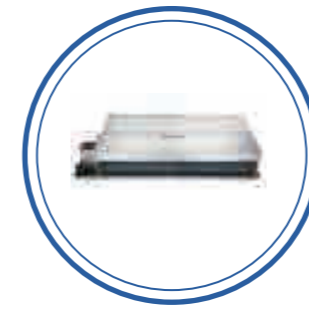

# Horizontal Concealed FCU Air Return From Back Side

## Specification-50Hz

Model	Left (Right)	KFU200NHL(R)-4B	KFU300NHL(R)-4B	KFU400NHL(R)-4B	KFU500NHL(R)-4B	KFU600NHL(R)-4B
Air Volume(H/M/L)	CFM	200/150/100	300/225/150	400/300/200	500/375/250	600/450/300
	m <sup>3</sup> /h	340/255/170	510/382/255	680/510/340	850/638/425	1020/765/510
Cooling Capacity	H/M/L Speed	W	1808/1537/1175	2712/2305/1763	3618/3075/2352	4514/3837/2934
	H/M/L Speed	W	2709/2303/1761	4070/3460/2646	5418/4605/3522	6767/5752/4399
External Static Pressure	Pa	12/30	12/30	12/30	12/30	12/30
Rows Of Coil		2	2	2	2	2
Noise Level	Low ESP	dB(A)	≤ 37	≤ 39	≤ 41	≤ 43
	Hi ESP	dB(A)	≤ 40	≤ 42	≤ 44	≤ 46
Fan Motor	Fan Quantity		1	2	2	2
	Motor Quantity		1	1	1	1
	Power Input	W	37/44	52/57	62/71	76/87
Water Flow Volume	m <sup>3</sup> /h	0.35	0.61	0.8	0.95	1.08
Hydraulic Resistance	kPa	10	12	20	37	39
Max.Working pressure	MPa	1.6	1.6	1.6	1.6	1.6
Dimension (WxDxH)	Net	mm	755x522x240	955x522x240	955x522x240	1190x522x240
	Packing	mm	780x560x280	980x560x280	980x560x280	1210x560x280
Net/Gross Weight	kg	14/16.5	17/20.3	17.5/20.8	20.5/24.1	21.5/25.1
Inlet/Outlet Water Pipe		Rc3/4" (DN20)				
Drain Pipe		R3/4" (DN20)				
Stuffing Quantity(20/40/40H)		248/512/576	192/384/432	192/384/432	144/312/351	144/312/351

## Specification-50Hz

Model	Left (Right)	KFU800NHL(R)-4B	KFU1000NHL(R)-4B	KFU1200NHL(R)-4B	KFU1400NHL(R)-4B	
Air Volume(H/M/L)	CFM	800/600/400	1000/750/500	1200/900/600	1400/1050/700	
	m <sup>3</sup> /h	1360/1020/680	1700/1275/850	2040/1530/1020	2380/1785/1190	
Cooling Capacity	H/M/L Speed	W	7210/6129/4687	9018/7665/5862	10810/9189/7027	12611/10719/8197
	H/M/L Speed	W	10807/9186/7025	13512/11485/8783	16205/13774/10533	18901/16066/12286
External Static Pressure	Pa	12/30	12/30	12/30	12/30	
Rows Of Coil		3	3	3	3	
Noise Level	Low ESP	dB(A)	≤ 48	≤ 50	≤ 52	
	Hi ESP	dB(A)	≤ 50	≤ 52	≤ 54	
Fan Motor	Fan Quantity		3	4	4	
	Motor Quantity		1	1	1	
	Power Input	W	156/173	174/210	212/249	
Water Flow Volume	m <sup>3</sup> /h	1.39	1.56	1.92	2.5	
Hydraulic Resistance	kPa	28	38	42	50	
Max.Working pressure	MPa	1.6	1.6	1.6	1.6	
Dimension (WxDxH)	Net	mm	1380x522x240	1780x522x240	1780x522x240	
	Packing	mm	1400x560x280	1800x560x280	1800x560x280	
Net/Gross Weight	kg	27.2/31.2	35/40	35.5/40.5	40/45.7	
Inlet/Outlet Water Pipe		Rc3/4" (DN20)				
Drain Pipe		R3/4" (DN20)				
Stuffing Quantity(20/40/40H)		128/264/297	104/208/234	104/208/234	88/184/207	

Note:  
 1. Cooling capacity test conditions: Air inlet Temp. : 27 °C DB/19.5 °C WB, Water inlet/outlet Temp. : 7 °C /12 °C ;  
 2. Heating capacity test conditions: Air inlet Temp. : 21 °C DB, Water inlet Temp. : 60 °C ;  
 3. Noise level is tested in full-anechoic room.





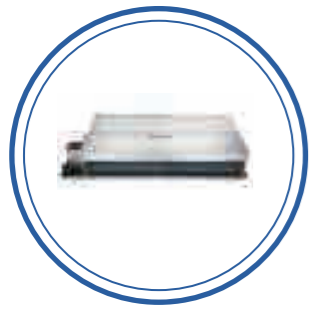

## Horizontal Concealed FCU Air Return From Down Side

### Specification-50Hz Series 6



Model	Left (Right)	KFU200NHL(R)-4DA	KFU300NHL(R)-4DA	KFU400NHL(R)-4DA	KFU500NHL(R)-4DA	KFU600NHL(R)-4DA	
Air Volume(H/M/L)	CFM	200/150/100	300/225/150	400/300/200	500/375/250	600/450/300	
	m <sup>3</sup> /h	340/255/170	510/382/255	680/510/340	850/638/425	1020/765/510	
Cooling Capacity	H/M/L Speed	1800/1537/1175	2700/2305/1763	3600/3075/2352	4500/3837/2934	5400/4595/3514	
Heating Capacity	H/M/L Speed	2700/2303/1761	4050/3460/2646	5400/4605/3522	6750/5752/4399	8100/6898/5275	
External Static Pressure	Pa	30	30	30	30	30	
Rows Of Coil		2	2	2	2	2	
Noise Level	dB(A)	≤ 40	≤ 42	≤ 44	≤ 46	≤ 47	
Fan Motor	Fan Quantity	1	2	2	2	2	
	Motor Quantity	1	1	1	1	1	
	Power Input	W	≤ 44	≤ 59	≤ 72	≤ 87	≤ 108
Water Flow Volume	m <sup>3</sup> /h	0.35	0.61	0.80	0.95	1.08	
Hydraulic Resistance	kPa	≤ 30	≤ 30	≤ 30	≤ 30	≤ 40	
Max.Working pressure	MPa	1.6	1.6	1.6	1.6	1.6	
Dimension	Net	mm	694 × 495 × 240	894 × 495 × 240	894 × 495 × 240	1039 × 495 × 240	1129 × 495 × 240
	Packing	mm	715 × 280 × 580	915 × 280 × 580	915 × 280 × 580	1060 × 280 × 580	1150 × 280 × 580
Net/Gross Weight	kg	14/16.5	17/20.3	17.5/20.8	20.5/24.1	21.5/25.1	
Inlet/Outlet Water Pipe				Rc3/4" (DN20)			
Drain Pipe				R3/4" (DN20)			
Stuffing Quantity(20/40/40H)		256/536/603	192/416/468	192/416/468	176/352/396	160/320/360	

### Specification-50Hz Series 6



Model	Left (Right)	KFU800NHL(R)-4DA	KFU1000NHL(R)-4DA	KFU1200NHL(R)-4DA	KFU1400NHL(R)-4DA	
Air Volume(H/M/L)	CFM	800/600/400	1000/750/500	1200/900/600	1400/1050/700	
	m <sup>3</sup> /h	1360/1020/680	1700/1275/850	2040/1530/1020	2380/1785/1190	
Cooling Capacity	H/M/L Speed	7200/6129/4687	9000/7665/5862	10800/9189/7027	12600/10719/8197	
Heating Capacity	H/M/L Speed	10800/9186/7025	13500/11485/8783	16200/13774/10533	18900/16066/12286	
External Static Pressure	Pa	30	30	30	30	
Rows Of Coil		3	3	3	3	
Noise Level	dB(A)	≤ 48	≤ 50	≤ 52	≤ 54	
Fan Motor	Fan Quantity	3	4	4	4	
	Motor Quantity	1	1	1	1	
	Power Input	W	≤ 156	≤ 174	≤ 212	≤ 253
Water Flow Volume	m <sup>3</sup> /h	1.39	1.56	1.92	2.50	
Hydraulic Resistance	kPa	≤ 40	≤ 40	≤ 40	≤ 50	
Max.Working pressure	MPa	1.6	1.6	1.6	1.6	
Dimension	Net	mm	1319 × 495 × 240	1619 × 495 × 240	1719 × 495 × 240	1909 × 495 × 240
	Packing	mm	1340 × 280 × 580	1640 × 280 × 580	1740 × 280 × 580	1930 × 280 × 580
Net/Gross Weight	kg	27.2/31.2	35/40	35.5/40.5	40/45.7	
Inlet/Outlet Water Pipe				Rc3/4" (DN20)		
Drain Pipe				R3/4" (DN20)		
Stuffing Quantity(20/40/40H)		136/272/306	104/224/252	104/208/234	96/192/216	

Note:  
 1. Cooling capacity test conditions: Air inlet Temp. : 27 °C DB/19.5 °C WB, Water inlet/outlet Temp. : 7 °C /12 °C ;  
 2. Heating capacity test conditions: Air inlet Temp. : 21 °C DB, Water inlet Temp. : 60 °C ;  
 3. Noise level is tested in full-anechoic room.



## Wall-mounted Fan Coil Unit



# Wall-Mounted Fan Coil Unit

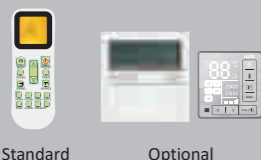

## Four Beautiful Appearance Panels Can Be Chosen



LH



LI



LR



LK

## Long Term Washable Air Filter

The wash period is two times longer than normal filter.



## Failure Automatic Detection

If there is a failure, the indicator will flash and the failure code will display on the wired controller, the failure cause is easier to be found.

## Two Way Value& Three Way Value (Optional)



Two way valve



Three way valve



## Wall-mounted FCU

### Specification-50Hz

Model		KFU200NW(LH)-4	KFU300NW(LH)-4	KFU400NW(LH)-4	KFU500NW(LH)-4	KFU600NW(LH)-4	KFU800NW(LH)-4	
Air Volume	CFM	200/150/100	300/225/150	400/300/200	500/375/250	600/450/300	800/600/400	
	m <sup>3</sup> /h	340/255/170	510/383/255	680/510/340	850/638/425	1020/765/510	1360/1020/680	
Cooling Capacity	W	1808/1537/1175	2712/2305/1763	3618/3075/2352	4514/3837/2934	5406/4595/3514	7210/6129/4687	
	H/M/L Speed							
Heating Capacity	W	2709/2303/1761	4070/3460/2646	5418/4605/3522	6767/5752/4399	8155/6989/5275	10807/9186/7025	
	H/M/L Speed							
Noise Level	dB(A)	≤ 42	≤ 42	≤ 43	≤ 47	≤ 47	≤ 49	
	Fan Quantity	1	1	1	1	1	1	
Fan Motor	Motor Quantity	1	1	1	1	1	1	
	Power Input	W	52	52	62	76	134	
Water Flow Volume	kg/h	350	610	800	950	1080	1390	
Hydraulic Resistance	kPa	30	30	30	30	40	40	
Max.Working pressure	MPa	1.6	1.6	1.6	1.6	1.6	1.6	
Dimension (WxDxH)	Net	mm	850 × 300 × 198	850 × 300 × 198	850 × 300 × 198	970 × 315 × 235	970 × 315 × 235	1100 × 330 × 235
	Packing	mm	885 × 360 × 270	885 × 360 × 270	885 × 360 × 270	1010 × 380 × 300	1010 × 380 × 300	1140 × 390 × 300
Net/Gross Weight	kg	11/12.5	11/12.5	12.6/14.5	15/17	16/18	20/23	
Inlet/Outlet Water Pipe			Rc1/2" (DN15)			Rc1/2" (DN15)		
Drain Pipe			R1/2" (DN15)			R1/2" (DN15)		
Stuffing Quantity(20/40/40H)		328/688/774	328/688/774	328/688/774	272/560/630	272/560/630	256/528/594	

### Specification-50Hz

Model		KFU200NW(LI)-4	KFU300NW(LI)-4	KFU400NW(LI)-4	KFU500NW(LI)-4	KFU600NW(LI)-4	KFU800NW(LI)-4	
Air Volume	CFM	200/150/100	300/225/150	400/300/200	500/375/250	600/450/300	800/600/400	
	m <sup>3</sup> /h	340/255/170	510/383/255	680/510/340	850/638/425	1020/765/510	1360/1020/680	
Cooling Capacity	W	1808/1537/1175	2712/2305/1763	3618/3075/2352	4514/3837/2934	5406/4595/3514	7210/6129/4687	
	H/M/L Speed							
Heating Capacity	W	2709/2303/1761	4070/3460/2646	5418/4605/3522	6767/5752/4399	8155/6989/5275	10807/9186/7025	
	H/M/L Speed							
Noise Level	dB(A)	≤ 42	≤ 42	≤ 43	≤ 47	≤ 47	≤ 49	
	Fan Quantity	1	1	1	1	1	1	
Fan Motor	Motor Quantity	1	1	1	1	1	1	
	Power Input	W	52	52	62	76	134	
Water Flow Volume	kg/h	350	610	800	950	1080	1390	
Hydraulic Resistance	kPa	30	30	30	30	40	40	
Max.Working pressure	MPa	1.6	1.6	1.6	1.6	1.6	1.6	
Dimension (WxDxH)	Net	mm	850 × 300 × 198	850 × 300 × 198	850 × 300 × 198	970 × 315 × 235	970 × 315 × 235	1100 × 330 × 235
	Packing	mm	885 × 360 × 270	885 × 360 × 270	885 × 360 × 270	1010 × 380 × 300	1010 × 380 × 300	1140 × 390 × 300
Net/Gross Weight	kg	11/12.5	11/12.5	12.6/14.5	15/17	16/18	20/23	
Inlet/Outlet Water Pipe			Rc1/2" (DN15)			Rc1/2" (DN15)		
Drain Pipe			R1/2" (DN15)			R1/2" (DN15)		
Stuffing Quantity(20/40/40H)		328/688/774	328/688/774	328/688/774	272/560/630	272/560/630	256/528/594	

Note:  
 1. Cooling capacity test conditions: Air inlet Temp. : 27 °C DB/19.5 °C WB, Water inlet/outlet Temp. : 7 °C /12 °C ;  
 2. Heating capacity test conditions: Air inlet Temp. : 21 °C DB, Water inlet Temp. : 60 °C ;  
 3. Noise level is tested in full-anechoic room.



## Wall-mounted FCU

### Specification-60Hz

Model		KFU200NW(LH)-2	KFU300NW(LH)-2	KFU400NW(LH)-2	KFU500NW(LH)-2	KFU600NW(LH)-2	KFU800NW(LH)-2
Air Volume	H/M/L Speed	CFM 200/150/100	300/225/150	400/300/200	500/375/250	600/450/300	800/600/400
		m³/h 340/255/170	510/383/255	680/510/340	850/638/425	1020/765/510	1360/1020/680
Cooling Capacity	H/M/L Speed	W 1808/1537/1175	2712/2305/1763	3618/3075/2352	4514/3837/2934	5406/4595/3514	7210/6129/4687
Heating Capacity	H/M/L Speed	W 2709/2303/1761	4070/3460/2646	5418/4605/3522	6767/5752/4399	8155/6989/5275	10807/9186/7025
Noise Level		dB(A) ≤ 42	≤ 42	≤ 43	≤ 47	≤ 47	≤ 49
Fan Motor	Fan Quantity	1	1	1	1	1	1
	Motor Quantity	1	1	1	1	1	1
	Power Input	W 52	52	62	76	96	134
Water Flow Volume		kg/h 350	610	800	950	1080	1390
Hydraulic Resistance		kPa 30	30	30	30	40	40
Max.Working pressure		MPa 1.6	1.6	1.6	1.6	1.6	1.6
Dimension (WxDxH)	Net	mm 850 × 300 × 198	850 × 300 × 198	850 × 300 × 198	970 × 315 × 235	970 × 315 × 235	1100 × 330 × 235
	Packing	mm 885 × 360 × 270	885 × 360 × 270	885 × 360 × 270	1010 × 380 × 300	1010 × 380 × 300	1140 × 390 × 300
Net/Gross Weight		kg 11/12.5	11/12.5	12.6/14.5	15/17	16/18	20/23
Inlet/Outlet Water Pipe			Rc1/2" (DN15)			Rc1/2" (DN15)	
Drain Pipe			R1/2" (DN15)			R1/2" (DN15)	
Stuffing Quantity(20/40/40H)		328/688/774	328/688/774	328/688/774	272/560/630	272/560/630	256/528/594

### Specification-60Hz

Model		KFU200NW(LI)-2	KFU300NW(LI)-2	KFU400NW(LI)-2	KFU500NW(LI)-2	KFU600NW(LI)-2	KFU800NW(LI)-2
Air Volume	H/M/L Speed	CFM 200/150/100	300/225/150	400/300/200	500/375/250	600/450/300	800/600/400
		m³/h 340/255/170	510/383/255	680/510/340	850/638/425	1020/765/510	1360/1020/680
Cooling Capacity	H/M/L Speed	W 1808/1537/1175	2712/2305/1763	3618/3075/2352	4514/3837/2934	5406/4595/3514	7210/6129/4687
Heating Capacity	H/M/L Speed	W 2709/2303/1761	4070/3460/2646	5418/4605/3522	6767/5752/4399	8155/6989/5275	10807/9186/7025
Noise Level		dB(A) ≤ 42	≤ 42	≤ 43	≤ 47	≤ 47	≤ 49
Fan Motor	Fan Quantity	1	1	1	1	1	1
	Motor Quantity	1	1	1	1	1	1
	Power Input	W 52	52	62	76	96	134
Water Flow Volume		kg/h 350	610	800	950	1080	1390
Hydraulic Resistance		kPa 30	30	30	30	40	40
Max.Working pressure		MPa 1.6	1.6	1.6	1.6	1.6	1.6
Dimension (WxDxH)	Net	mm 850 × 300 × 198	850 × 300 × 198	850 × 300 × 198	970 × 315 × 235	970 × 315 × 235	1100 × 330 × 235
	Packing	mm 885 × 360 × 270	885 × 360 × 270	885 × 360 × 270	1010 × 380 × 300	1010 × 380 × 300	1140 × 390 × 300
Net/Gross Weight		kg 11/12.5	11/12.5	12.6/14.5	15/17	16/18	20/23
Inlet/Outlet Water Pipe			Rc1/2" (DN15)			Rc1/2" (DN15)	
Drain Pipe			R1/2" (DN15)			R1/2" (DN15)	
Stuffing Quantity(20/40/40H)		328/688/774	328/688/774	328/688/774	272/560/630	272/560/630	256/528/594

Note:  
 1. Cooling capacity test conditions: Air inlet Temp. : 27 °C DB/19.5 °C WB, Water inlet/outlet Temp. : 7 °C /12 °C ;  
 2. Heating capacity test conditions: Air inlet Temp. : 21 °C DB, Water inlet Temp. : 60 °C ;  
 3. Noise level is tested in full-anechoic room.

## Nomenclature

### Indoor Unit

K NC T 24 H - 4 V R1 H A

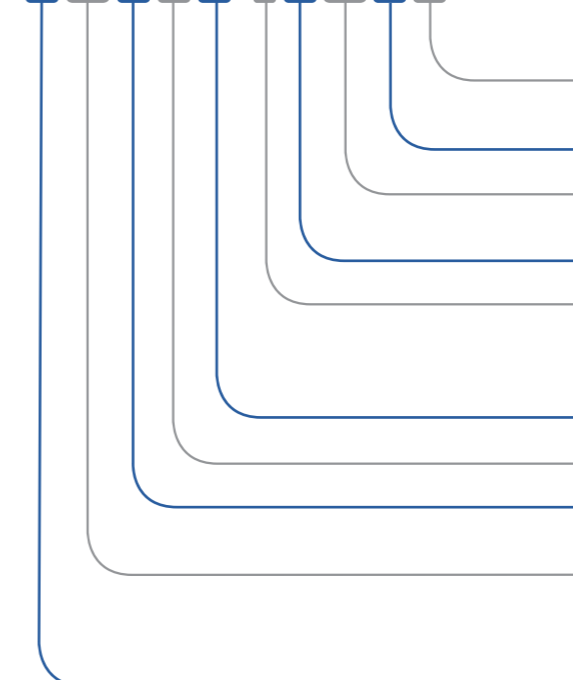

Design Series Code  
 A: 1<sup>st</sup> Designed  
 B: 2<sup>nd</sup> Designed

E: High Efficiency Type  
 Normal Type Omitted

Refrigerant Type:  
 R1: R410a.  
 R22 Omitted

V: DC Inverter  
 ON/OFF Omitted

Power Supply:  
 2: 208-230V~, 1Ph, 60Hz  
 5: 380-415V~, 3Ph, 50Hz  
 9: 208-230V~, 3Ph, 60Hz

4: 220-240V~, 1Ph, 50Hz  
 6: 380-415V~, 3Ph, 60Hz

H: Cooling & Heating  
 C: Cooling Only

Cooling Capacity (k Btu/h)

Climate Class:  
 T: T3 Type  
 T1 Omitted

Indoor Unit Type:  
 NC: Four-Way Cassette  
 NL: Low ESP Duct  
 NH: High ESP Duct

NE: Ceiling&Floor  
 NM: Mid ESP Duct  
 NF: Floor-Standing

AUKIA

### Outdoor Unit

K OU T 24 H - 4 V R1 E A

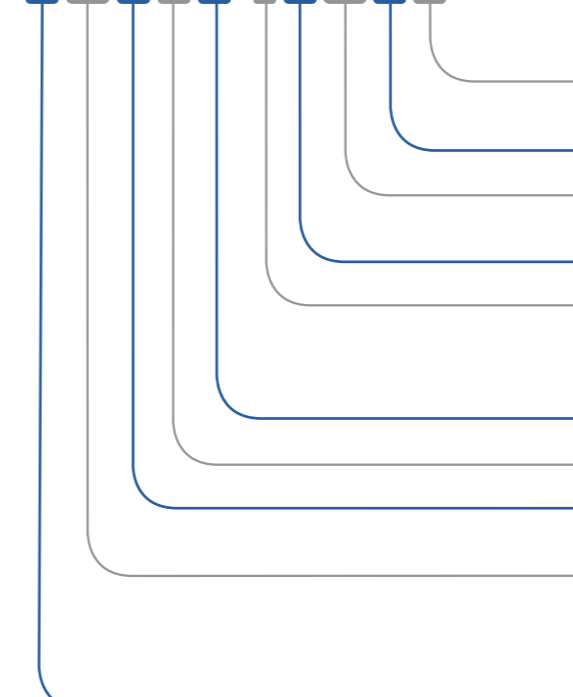

Design Series Code  
 A: 1<sup>st</sup> Designed  
 B: 2<sup>nd</sup> Designed

E: High Efficiency Type  
 Normal Type Omitted

Refrigerant Type:  
 R1: R410a.  
 R22 Omitted

V: DC Inverter  
 ON/OFF Omitted

Power Supply:  
 2: 208-230V~, 1Ph, 60Hz  
 5: 380-415V~, 3Ph, 50Hz  
 9: 208-230V~, 3Ph, 60Hz

4: 220-240V~, 1Ph, 50Hz  
 6: 380-415V~, 3Ph, 60Hz

H: Cooling & Heating  
 C: Cooling Only

Cooling Capacity (k Btu/h)

Climate Class:  
 T: T3 Type  
 T1 Omitted

Outdoor Unit Type:  
 OU: Universal Outdoor Unit  
 HD: High ESP Duct Outdoor Unit  
 FS: Floor-standing Outdoor Unit  
 TU: Top Discharge Outdoor Unit

AUKIA

# Nomenclature-Free Match

## Indoor Unit

**K M NC 12 H - 4 V R1 A**

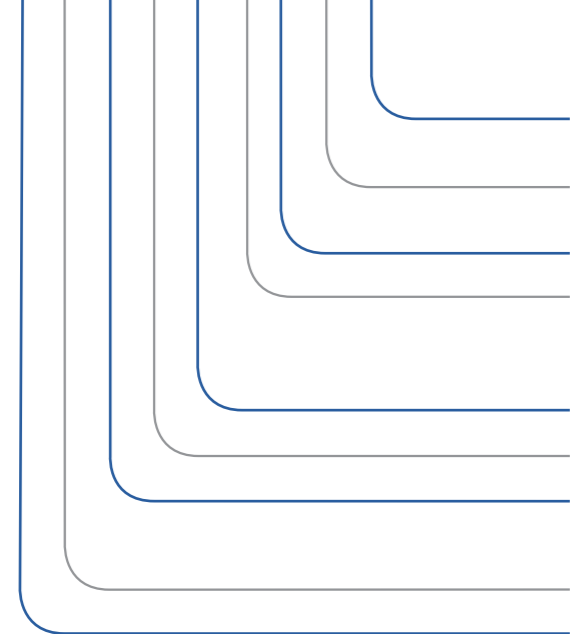

**Design Series Code**  
A: 1<sup>st</sup> Designed      B: 2<sup>nd</sup> Designed

**Refrigerant Type:**  
R1: R410a.      R22 Omitted

**V: DC Inverter**      ON/OFF Omitted

**Power Supply:**  
2: 208-230V~, 1Ph, 60Hz      4: 220-240V~, 1Ph, 50Hz  
5: 380-415V~, 3Ph, 50Hz      6: 380-415V~, 3Ph, 60Hz  
9: 208-230V~, 3Ph, 60Hz

**H: Cooling & Heating**      C: Cooling Only

**Cooling Capacity (k Btu/h)**

**Indoor Unit Type:**  
NC: Four-Way Cassette      NE: Ceiling&Floor  
NS: Low ESP Duct      NW: Wall-mounted

Mult-split AC

AUKIA

## Outdoor Unit

**K M D 24 H - 4 V R1 A**

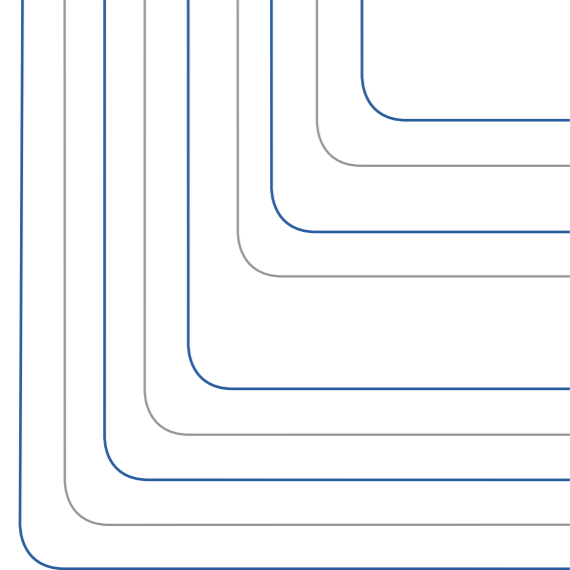

**Design Series Code**

**Refrigerant Type:**  
R1: R410a.      R22 Omitted

**V: DC Inverter**      ON/OFF Omitted

**Power Supply:**  
2: 208-230V~, 1Ph, 60Hz      4: 220-240V~, 1Ph, 50Hz  
5: 380-415V~, 3Ph, 50Hz      6: 380-415V~, 3Ph, 60Hz  
9: 208-230V~, 3Ph, 60Hz

**H: Cooling & Heating**      C: Cooling Only

**Cooling Capacity (k Btu/h)**

**D: 1 drive 2    T: 1 drive 3**      **F: 1 drive 4    V: 1 drive 5**

Mult-split AC

AUKIA

# Europe Series DC Inverter



# Europe Series- Outdoor Unit



## High Efficiency

Equipped with high efficiency DC Inverter compressor, adjustable fan motor and advanced 180° sine wave vector driver, the system can be higher than 4.0 in SCOP so as to meet the European and Australian new energy efficiency standards.

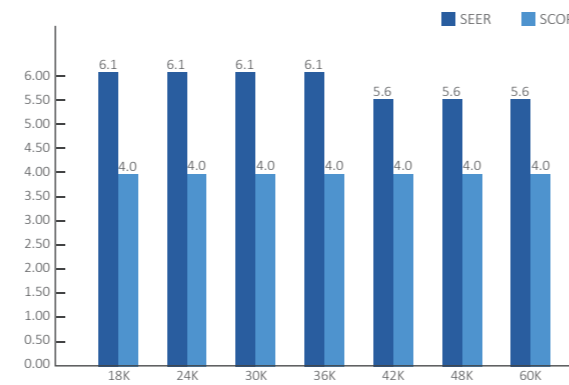

## Reliability

Stable cooling under -5°C and heating under -15°C outdoor environment temperature.

## 180° Sine Wave Control

DC inverter compressor uses 180° sine wave vector control technique, make motor operate smoothly and efficiency increases significantly.

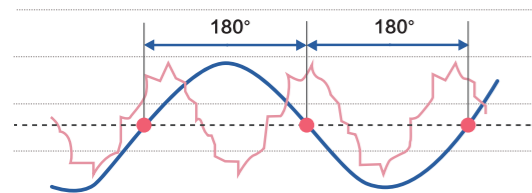

## Optimized Pipeline Design

The design ensures the sub-cooling and enhances the cooling capacity by separating the refrigerant inlet and outlet.

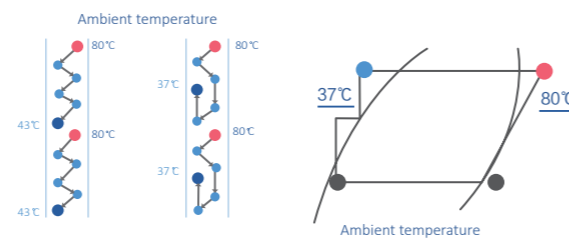

## Simulation Technology

Via analysing piping stress distribution, piping amplitude and displacement in transportation and operation, the reliability has been improved greatly.

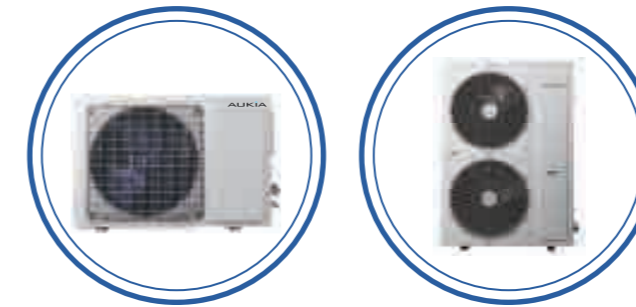
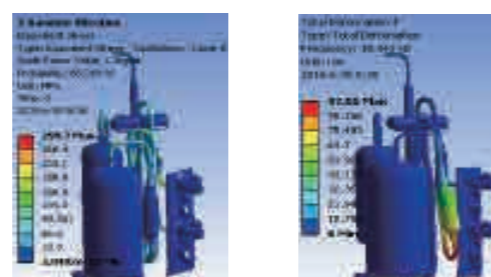

# Europe Series- Outdoor Units

## Specification-R410a 50Hz DC Inverter

Model	Outdoor		KOU18H-4VR1E	KOU24H-4VR1E	KOU30H-4VR1E	KOU36H-4VR1E
Electric Data	Power Supply	V~,Hz,Ph	220-240,50,1	220-240,50,1	220-240,50,1	220-240,50,1
	Air Flow Volume	m³/h	2600	3750	3750	6400
Performance	Sound Pressure Noise Level	dB(A)	55	58	59	58
	Sound Power Noise Level	dB(A)	64	66	68	67
Dimension (WxDxH)	Net	mm	800 × 286 × 530	890 × 320 × 670	890 × 320 × 670	940 × 368 × 1366
	Packing	mm	920x400x620	1020x430x760	1020x430x760	1080 × 460 × 1500
Weight	Net/Gross	kg	40/44	53/58	54/59	93/103
	Liquid Side	mm(inch)	6.35(1/4)	9.52(3/8)	9.52(3/8)	9.52(3/8)
Piping size	Gas Side	mm(inch)	12.7(1/2)	15.88(5/8)	15.88(5/8)	15.88(5/8)
	Max. Length	m	20	30	30	30
	Max. Height	m	15	15	15	15
Stuffing Quantity	20/40/40H	unit	102/219/292	87/183/183	87/183/183	27/55/55

## Specification-R410a 50Hz DC Inverter

Model	Outdoor		KOU42H-4VR1E	KOU48H-5VR1E	KOU60H-5VR1E
Electric Data	Power Supply	V~,Hz,Ph	220-240,50,1	380-415,50,3	380-415,50,3
	Air Flow Volume	m³/h	6400	6400	6400
Performance	Sound Pressure Noise Level	dB(A)	58	59	59
	Sound Power Noise Level	dB(A)	67	68	68
Dimension (WxDxH)	Net	mm	940 × 368 × 1366	940 × 368 × 1366	940 × 368 × 1366
	Packing	mm	1080 × 460 × 1500	1080 × 460 × 1500	1080 × 460 × 1500
Weight	Net/Gross	kg	93/103	108/116	108/116
	Liquid Side	mm(inch)	9.52(3/8)	9.52(3/8)	9.52(3/8)
Piping size	Gas Side	mm(inch)	15.88(5/8)	19.05(3/4)	19.05(3/4)
	Max. Length	m	30	50	50
	Max. Height	m	15	30	30
Stuffing Quantity	20/40/40H	unit	27/55/55	27/55/55	27/55/55

\* Remark: The above designs and specifications are subject to change without prior notice. Final specifications please refer to technical specification provided by sales representative.



# Europe Series- Four-Way Cassette

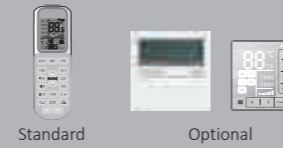

Standard

Optional

## Europe Series Four-way Cassette

### Built-In Water Drainage Pump

The built-in pump can lift condensing water up to 1200mm high from the drainage pan.

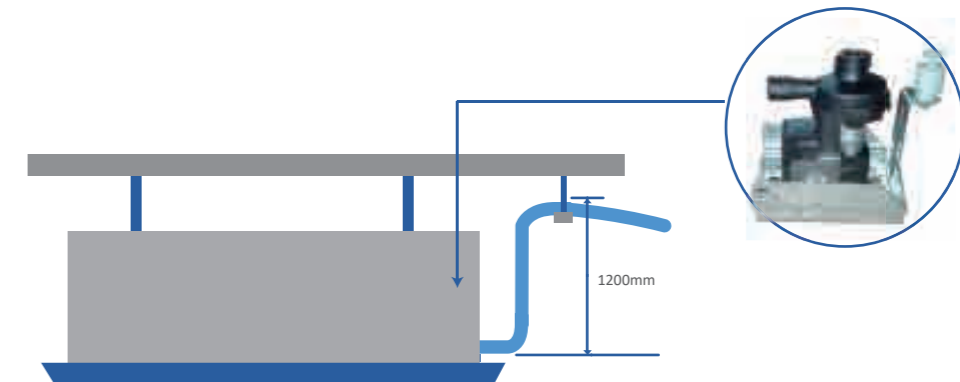

### Fresh Air Intake

Fresh air makes indoor air healthy and comfortable.



Fresh air intake

### Optimized Electric Box

Better fire-proof and easy to maintenance.

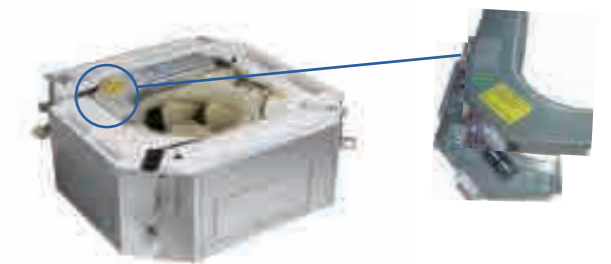

### FEATURES

■ optional ■ standard

- Remote Control
- Built-in Drain Pump
- Auto Restart Function
- Digital Tube Display
- Hydrophilic Aluminum Fin
- Washable Filter
- Fast Cooling/Heating
- Fresh Air Intake
- Low Ambient Cooling
- Fire-proof Electric Box
- Wired Control
- Central Control
- Golden Fin
- WiFi Control

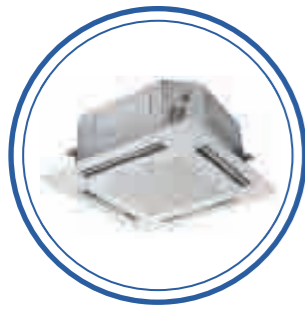

## Europe Series- Four-Way Cassette

### Specification-R410a 50Hz DC Inverter



Model	Indoor		KNC18H-4VR1E	KNC24H-4VR1E	KNC30H-4VR1E	KNC36H-4VR1E	
	Outdoor		KOU18H-4VR1E	KOU24H-4VR1E	KOU30H-4VR1E	KOU36H-4VR1E	
Capacity	Cooling/Heating	Btu/h	18000(5220-19100)/19100(4800-21200)	18000(5220-19100)/19100(4800-21200)	24000(7400-28000)/27300(6800-31800)	30000(8500-31400)/30800(9800-32800)	
		kW	5.00(1.53-5.60)/5.60(1.40-6.20)	5.00(1.53-5.60)/5.60(1.40-6.20)	7.00(2.16-8.20)/8.00(1.98-9.30)	8.30(2.49-9.20)/9.00(2.86-9.60)	
Electric Data	Power Supply	V~Hz,Ph	220-240,50,1	220-240,50,1	220-240,50,1	220-240,50,1	
		Cooling /HeatingPower Input	kW	1.54(0.47-2.30)/1.55(0.46-2.25)	1.54(0.47-2.30)/1.55(0.46-2.25)	2.05(0.67-3.56)/2.20(0.65-3.62)	2.68(0.77-3.70)/2.62(0.78-3.70)
Performance	SEER/SCOP	WW	6.1/4.0	6.1/4.0	6.1/4.0	6.1/4.0	
		ERP Energy Efficiency Class	A++/A+	A++/A+	A++/A+	A++/A+	
		Air Flow Volume	m <sup>3</sup> /h	800/670/550	800/670/550	1300/1050/950	1400/1150/1000
		Sound Pressure Noise Level	dB(A)	46/44/36	46/44/36	47/43/38	48/44/39
Dimension (WxDxH)	Net(Body)	mm	570 × 570 × 260	615 × 615 × 263	835 × 835 × 250	835 × 835 × 250	
		Packing(Body)	mm	640 × 640 × 290	700 × 700 × 330	910 × 910 × 310	910 × 910 × 310
		Net(Panel)	mm	650 × 650 × 55	650 × 650 × 55	950 × 950 × 55	950 × 950 × 55
		Packing(Panel)	mm	710 × 710 × 80	710 × 710 × 80	1000 × 1000 × 100	1000 × 1000 × 100
Weight	Net/Gross(Body)	kg	19/23	19/23	24/27.5	24/27.5	
		Net/Gross(Panel)	kg	3/5	3/5	5/7	5/7
Piping size	Drainage	mm(inch)	DN20(R3/4)	DN20(R3/4)	DN20(R3/4)	DN20(R3/4)	
Applicable Area		m <sup>2</sup>	21-35	21-35	28-47	32-60	
Stuffing Quantity	20/40/40H	set	66/137/161	66/137/161	42/82/92	42/82/92	

### Specification-R410a 50Hz DC Inverter



Model	Indoor		KNC42H-4VR1E	KNC48H-5VR1E	KNC60H-5VR1E	ALCA-H60/5DR1H	
	Outdoor		KOU42H-4VR1E	KOU48H-5VR1E	KOU60H-5VR1E	AL-H60/5DR1H(U)	
Capacity	Cooling/Heating	Btu/h	36000(9900-41000)/42650(8900-41000)	42000(10900-45000)/46000(10200-50150)	48000(14000-54600)/55000(15700-59700)	55000(16400-59000)/60000(16700-63100)	
		kW	10.5(2.9-12.0)/12.5(2.6-13.2)	12.1(3.2-13.2)/13.5(3.0-14.7)	14.00(4.10-16.00)/16.00(4.60-17.50)	16.00(4.80-17.30)/17.00(4.90-18.50)	
Electric Data	Power Supply	V~Hz,Ph	220-240,50,1	220-240,50,1	380-415,50,3	380-415,50,3	
		Cooling /HeatingPower Input	kW	3.28(0.71-4.71)/3.64(0.47-4.13)	4.28(0.8-5.39)/4.10(0.58-4.90)	4.95(1.21-6.48)/4.57(0.92-5.66)	5.71(1.38-6.85)/4.96(0.98-6.00)
Performance	SEER/SCOP	WW	6.1/4.0	5.6/4.0	5.6/4.0	5.6/4.0	
		ERP Energy Efficiency Class	A++/A+	A+/A+	A+/A+	A+/A+	
		Air Flow Volume	m <sup>3</sup> /h	1800/1550/1350	1800/1550/1350	2050/1750/1500	2050/1750/1500
		Sound Pressure Noise Level	dB(A)	51/48/45	51/48/45	53/48/42	53/48/42
Dimension (WxDxH)	Net(Body)	mm	835 × 835 × 290	835 × 835 × 290	835 × 835 × 290	835 × 835 × 290	
		Packing(Body)	mm	910 × 910 × 350	910 × 910 × 350	910 × 910 × 350	910 × 910 × 350
		Net(Panel)	mm	950 × 950 × 55	950 × 950 × 55	950 × 950 × 55	950 × 950 × 55
		Packing(Panel)	mm	1000 × 1000 × 100	1000 × 1000 × 100	1000 × 1000 × 100	1000 × 1000 × 100
Weight	Net/Gross(Body)	kg	26.5/30.5	26.5/30.5	26.5/30.5	26.5/30.5	
		Net/Gross(Panel)	kg	5/7	5/7	5/7	5/7
Piping size	Drainage	mm(inch)	DN20(R3/4)	DN20(R3/4)	DN20(R3/4)	DN20(R3/4)	
Applicable Area		m <sup>2</sup>	56-93	64-107	64-107	64-107	
Stuffing Quantity	20/40/40H	set	22/50/55	22/50/55	22/50/55	22/50/55	

\* Remark: The above designs and specifications are subject to change without prior notice. Final specifications please refer to technical specification provided by sales representative.

## Europe Series Ceiling & Floor



### FEATURES

■ optional ■ standard

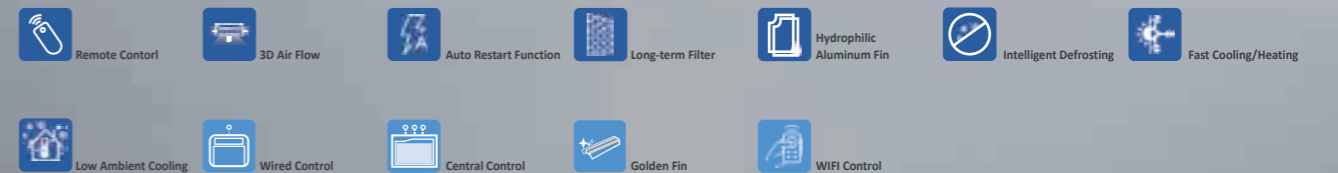

# Europe Series- Ceiling&Floor

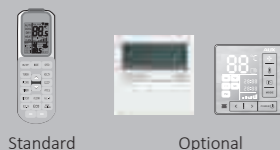

## 4D Air Swing

Vertical and horizontal swing makes air below to every corner of the room.



## Ultra Slim Design

The thickness is only 205mm, save installation space.



## Innovative Centrifugal Fan

All units are equipped with 3-speed fan mode, adjusting the air flow rate in accordance with the ceiling height. Innovative centrifugal fan provides larger air volume but lower noise, making the air supply more quietly and smoothly.



## Flexible Installation

Can be vertically installed against the wall or horizontally installed under the ceiling.

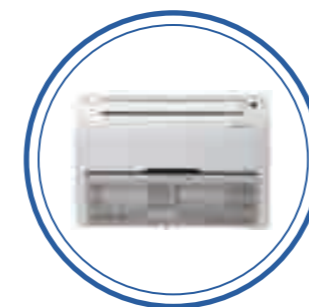
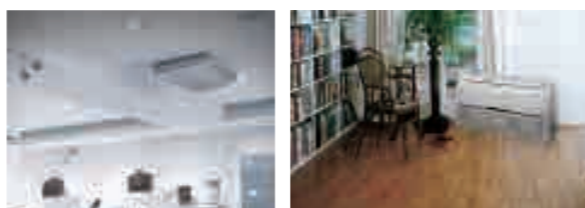

# Europe Series- Ceiling&Floor

## Specification-R410a 50Hz DC Inverter

Model	Indoor	KNE18H-4VR1E	KNE24H-4VR1E	KNE30H-4VR1E	KNE36H-4VR1E
	Outdoor	KOU18H-4VR1E	KOU24H-4VR1E	KOU30H-4VR1E	KOU36H-4VR1E
Capacity	Cooling/Heating	Btu/h 18000(5220-19100)/19100(4800-21200)	24000(7400-28000)/27300(6800-31800)	30000(8500-31400)/30800(9800-32800)	36000(9900-40900)/42650(8900-45000)
		kW 5.00(1.53-5.60)/5.60(1.40-6.20)	7.00(2.16-8.20)/8.00(1.98-9.30)	8.30(2.49-9.20)/9.00(2.86-9.60)	10.5(2.9-12.0)/12.5(2.6-13.2)
Electric Data	Power Supply	V~,Hz,Ph 220-240,50,1	220-240,50,1	220-240,50,1	220-240,50,1
	Cooling /HeatingPower Input W	1.54(0.47-2.30)/1.55(0.46-2.25)	2.05(0.67-3.56)/2.20(0.65-3.62)	2.68(0.77-3.70)/2.62(0.78-3.70)	3.28(0.71-4.71)/3.64(0.47-4.13)
Performance	SEER/SCOP	WW 6.1/4.0	6.1/4.0	6.1/4.0	6.1/4.0
	ERP Energy Efficiency Class	A++/A+	A++/A+	A++/A+	A++/A+
	Air Flow Volume	m <sup>3</sup> /h 900/730/650	1300/1052/920	1400/1200/1000	1800/1550/1350
	Sound Pressure Noise Level	dB(A) 45/42/37	47/45/43	48/46/43	53/50/47
	Sound Power Noise Level	dB(A) 55	57	58	63
Dimension (WxDxH)	Net	mm 930 × 660 × 205	1280 × 660 × 205	1280 × 660 × 205	1630 × 660 × 205
	Packing	mm 1010 × 720 × 290	1360 × 720 × 290	1360 × 720 × 290	1710 × 720 × 290
Weight	Net/Gross	kg 25/28	32/38	32/38	44/50
Piping size	Drainage	mm(inch) DN20(R3/4)	DN20(R3/4)	DN20(R3/4)	DN20(R3/4)
Applicable Area		m <sup>2</sup> 21-35	28-47	32-60	56-93
Stuffing Quantity	20/40/40H	set 60/134/149	43/92/104	43/92/104	22/55/55

## Specification-R410a 50Hz DC Inverter

Model	Indoor	KNE42H-4VR1E	KNE48H-5VR1E	KNE60H-5VR1E
	Outdoor	KOU42H-4VR1E	KOU48H-5VR1E	KOU60H-5VR1E
Capacity	Cooling/Heating	Btu/h 41285(10900-45000)/46062(10200-50150)	48000(14000-54600)/55000(15700-59700)	55000(16400-59000)/60000(16700-63100)
		kW 12.1(3.2-13.2)/13.5(3.0-14.7)	14.00(4.10-16.00)/16.00(4.60-17.50)	16.00(4.80-17.30)/17.00(4.90-18.50)
Electric Data	Power Supply	V~,Hz,Ph 220-240,50,1	380-415,50,3	380-415,50,3
	Cooling /HeatingPower Input W	4.28 (0.8-5.39)/4.10(0.58-4.90)	4.95(1.21-6.48)/4.57(0.92-5.66)	5.80(1.38-6.85)/4.96(0.98-6.00)
Performance	SEER/SCOP	WW 5.6/4.0	5.6/4.0	5.6/4.0
	ERP Energy Efficiency Class	A+/A+	A+/A+	A++/A+
	Air Flow Volume	m <sup>3</sup> /h 1800/1550/1350	2000/1600/1400	2000/1600/1400
	Sound Pressure Noise Level	dB(A) 53/50/47	54/50/46	54/50/46
	Sound Power Noise Level	dB(A) 63	64	64
Dimension (WxDxH)	Net	mm 1630 × 660 × 205	1630 × 660 × 205	1630 × 660 × 205
	Packing	mm 1710 × 720 × 290	1710 × 720 × 290	1710 × 720 × 290
Weight	Net/Gross	kg 44/50	44/50	44/50
Piping size	Drainage	mm(inch) DN20(R3/4)	DN20(R3/4)	DN20(R3/4)
Applicable Area		m <sup>2</sup> 64-107	64-107	64-107
Stuffing Quantity	20/40/40H	set 22/55/55	22/55/55	22/55/55

\* Remark: The above designs and specifications are subject to change without prior notice. Final specifications please refer to technical specification provided by sales representative.

# Europe Series- Mid ESP Duct



Standard

Optional

## Europe Series Mid ESP Dust

### FEATURES

- Wired Control
- 3D Air Flow
- Auto Restart Function
- Long-term Filter
- Hydrophilic Aluminum Fin
- Intelligent Defrosting
- Fast Cooling/Heating
- Low Ambient Cooling
- Remote control
- Central Control
- Golden Fin
- WIFI Control

■ optional ■ standard

### Built In Water Pump (Optional)

The built-in pump can lift condensing water up to 1200mm high from the drainage pan.

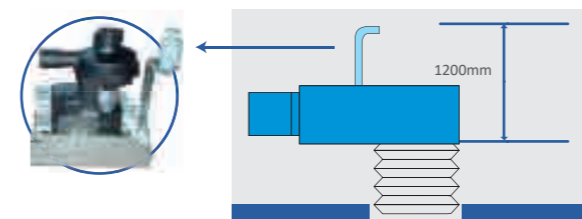

### Optional ESP (Mid ESP)

50Pa and 80Pa can be freely chosen.

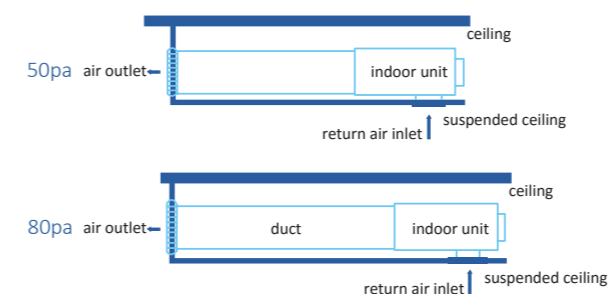

### Flexible Air Intake Options

Air intake from rear as standard, from bottom is optional. The size of the plate from bottom is the same as the flange from back, which makes it convenient to change installation style due to different decoration requirements.

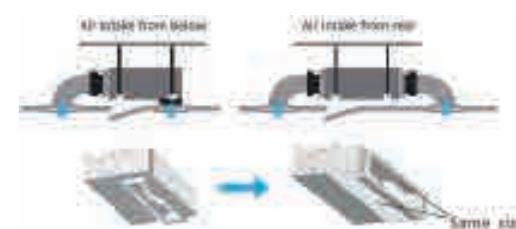

### Fresh Air Intake

Fresh air makes indoor air healthy and comfortable.

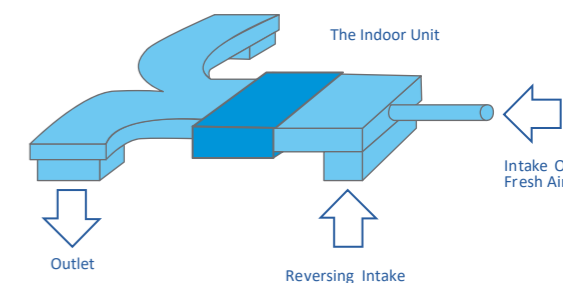

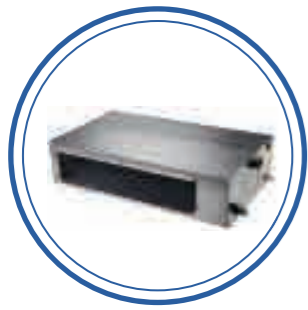

## Europe Series- Mid ESP Duct

### Specification-R410a 50Hz DC Inverter



Model	Indoor		KNM18H-4VR1E	KNM24H-4VR1E	KNM30H-4VR1E	KNM36H-4VR1E
	Outdoor		KOU18H-4VR1E	KOU24H-4VR1E	KOU30H-4VR1E	KOU36H-4VR1E
Capacity	Cooling/Heating	Btu/h	18000(5220-19100)/19100(4800-21200)	24000(7400-28000)/27300(6800-31800)	30000(8500-31400)/30800(9800-32800)	36000(9900-40900)/42650(8900-45000)
		kW	5.00(1.53-5.60)/5.60(1.40-6.20)	7.00(2.16-8.20)/8.00(1.98-9.30)	8.30(2.49-9.20)/9.00(2.86-9.60)	10.5(2.9-12.0)/12.5(2.6-13.2)
Electric Data	Power Supply	V~,Hz,Ph	220-240,50,1	220-240,50,1	220-240,50,1	220-240,50,1
		Cooling/Heating Power Input kW	1.54(0.47-2.30)/1.55(0.46-2.25)	2.05(0.67-3.56)/2.20(0.65-3.62)	2.68(0.77-3.70)/2.62(0.78-3.70)	3.28(0.71-4.71)/3.64(0.47-4.13)
Performance	SEER/SCOP	WW	6.1/4.0	6.1/4.0	6.1/4.0	6.1/4.0
	ERP Energy Efficiency Class		A++/A+	6.1/4.0	A++/A+	A++/A+
	Air Flow Volume	m <sup>3</sup> /h	1150/960/840	1400/1190/980	1500/1300/1120	2000/1700/1450
	Sound Pressure Noise Level	dB(A)	42/40/37	46/42/38	47/43/40	51/48/45
	Sound Power Noise Level	dB(A)	52	56	57	62
	ESP	Pa	0-50	0-80	0-80	0-80
Dimension	Net	mm	890 × 785 × 290	890 × 785 × 290	890 × 785 × 290	1250 × 785 × 290
	(WxDxH) Packing	mm	1100 × 870 × 360	1100 × 870 × 360	1100 × 870 × 360	1460 × 870 × 360
Weight	Net/Gross	kg	34/40	36/42	36/42	52/59
Piping size	Drainage	mm(inch)	DN20(R3/4)	DN20(R3/4)	DN20(R3/4)	DN20(R3/4)
Applicable Area		m <sup>2</sup>	21-35	28-47	32-60	56-93
Stuffing Quantity	20/40/40H	set	43/95/110	36/78/94	36/78/94	21/44/47

### Specification-R410a 50Hz DC Inverter



Model	Indoor		KNM42H-4VR1E	KNM48H-5VR1E	KNM60H-5VR1E
	Outdoor		KOU42H-4VR1E	KOU48H-5VR1E	KOU60H-5VR1E
Capacity	Cooling/Heating	Btu/h	41285(10900-45000)/46062(10200-50150)	48000(14000-54600)/55000(15700-59700)	55000(16400-59000)/60000(16700-63100)
		kW	12.1(3.2-13.2)/13.5(3.0-14.7)	14.00(4.10-16.00)/16.00(4.60-17.50)	16.00(4.80-17.30)/17.00(4.90-18.50)
Electric Data	Power Supply	V~,Hz,Ph	220-240,50,1	380-415,50,3	380-415,50,3
		Cooling/Heating Power Input kW	4.28(0.8-5.39)/4.10(0.58-4.90)	4.67(1.21-6.48)/4.57(0.92-5.66)	5.61(1.38-6.85)/4.96(0.98-6.00)
Performance	SEER/SCOP	WW	5.6/4.0	5.6/4.0	5.6/4.0
	ERP Energy Efficiency Class		A+/A+	A+/A+	A+/A+
	Air Flow Volume	m <sup>3</sup> /h	2000/1700/1450	2600/2000/1650	2600/2000/1650
	Sound Pressure Noise Level	dB(A)	51/48/45	52/49/46	52/49/46
	Sound Power Noise Level	dB(A)	62	62	62
	ESP	Pa	0-80	0-80	0-80
Dimension	Net	mm	1250 × 785 × 290	1250 × 785 × 290	1250 × 785 × 290
	(WxDxH) Packing	mm	1460 × 870 × 360	1460 × 870 × 360	1460 × 870 × 360
Weight	Net/Gross	kg	52/59	52/59	52/59
Piping size	Drainage	mm(inch)	DN20(R3/4)	DN20(R3/4)	DN20(R3/4)
Applicable Area		m <sup>2</sup>	64-107	64-107	64-107
Stuffing Quantity	20/40/40H	set	21/44/47	21/44/47	21/44/47

\* Remark: The above designs and specifications are subject to change without prior notice. Final specifications please refer to technical specification provided by sales representative.



## Europe Series Free Match

# Europe Series- Free Match



## Space-Saving Installation

Up to 5 indoor units can be connected to a single outdoor unit, which reduces the number of outdoor units required so as to save installation space. Besides, each indoor unit can be controlled individually and they even needn't to be installed at the same time.

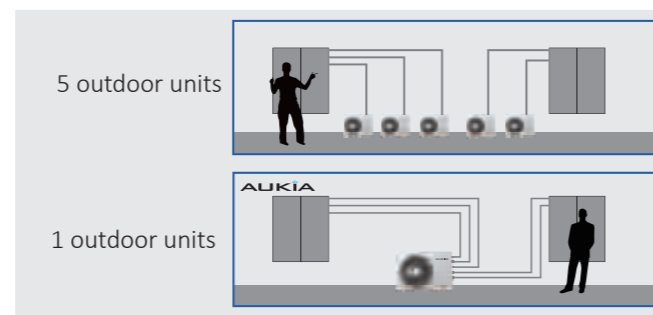

## Flexible Installation

Up to 60m of total piping length and 10m of the maximum height difference, it's more convenient for the location of indoor and outdoor units, also making the installation more simple, flexible and economical.

## Energy Saving

Cutting-edge DC inverter of sine wave control and active PFC technology realize low noise and economical operation.

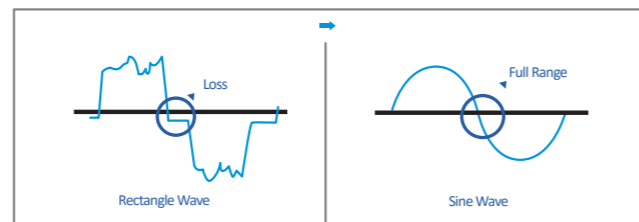

## Low Ambient Cooling

The unit has the feature that keeping running under low ambient temperature, even in -5°C.

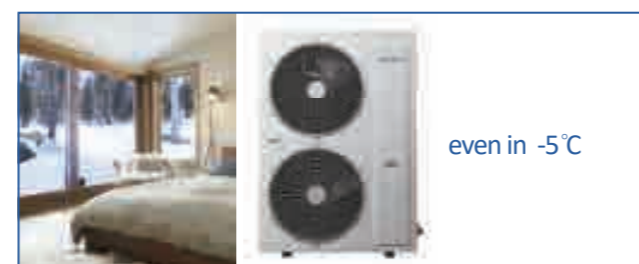

# Free Match Combination

## Combination Table

Multi DC Outdoor Unit	Available Indoor Unit	Suggested Combination																									
<b>1 drive 2</b> KMD18H-4VR1	Wall mounted: 7k/9k/12k/18k 4-way Cassette: 9k/12k/18k Ceiling Floor: 9k/12k/18k Slim Duct: 7k/9k/12k/18k	<table border="1"> <thead> <tr> <th>One Unit</th> <th>Two Units</th> </tr> </thead> <tbody> <tr> <td>7</td> <td>7+7, 9+9</td> </tr> <tr> <td>9</td> <td>7+9, 9+12</td> </tr> <tr> <td>12</td> <td>7+12, 12+12</td> </tr> </tbody> </table>	One Unit	Two Units	7	7+7, 9+9	9	7+9, 9+12	12	7+12, 12+12																	
		One Unit	Two Units																								
7	7+7, 9+9																										
9	7+9, 9+12																										
12	7+12, 12+12																										
<b>1 drive 3</b> KMT24H-4VR1	Wall mounted: 7k/9k/12k/18k 4-way Cassette: 9k/12k/18k Ceiling Floor: 9k/12k/18k Slim Duct: 7k/9k/12k/18k	<table border="1"> <thead> <tr> <th>One Unit</th> <th>Two Units</th> <th>Three Units</th> </tr> </thead> <tbody> <tr> <td>7</td> <td>7+7, 9+12</td> <td>7+7+7, 7+9+12</td> </tr> <tr> <td>9</td> <td>7+9, 9+18</td> <td>7+7+9, 7+12+12</td> </tr> <tr> <td>12</td> <td>7+12, 12+12</td> <td>7+7+12, 9+9+9</td> </tr> <tr> <td>18</td> <td>7+18, 12+18</td> <td>7+7+18, 9+9+12</td> </tr> <tr> <td></td> <td>9+9</td> <td>7+9+9, 9+12+12</td> </tr> </tbody> </table>	One Unit	Two Units	Three Units	7	7+7, 9+12	7+7+7, 7+9+12	9	7+9, 9+18	7+7+9, 7+12+12	12	7+12, 12+12	7+7+12, 9+9+9	18	7+18, 12+18	7+7+18, 9+9+12		9+9	7+9+9, 9+12+12							
		One Unit	Two Units	Three Units																							
7	7+7, 9+12	7+7+7, 7+9+12																									
9	7+9, 9+18	7+7+9, 7+12+12																									
12	7+12, 12+12	7+7+12, 9+9+9																									
18	7+18, 12+18	7+7+18, 9+9+12																									
	9+9	7+9+9, 9+12+12																									
<b>1 drive 3</b> KMT27H-4VR1	Wall mounted: 7k/9k/12k/18k 4-way Cassette: 9k/12k/18k Ceiling Floor: 9k/12k/18k Slim Duct: 7k/9k/12k/18k	<table border="1"> <thead> <tr> <th>One Unit</th> <th>Two Units</th> <th>Three Units</th> </tr> </thead> <tbody> <tr> <td>7</td> <td>7+7, 9+12</td> <td>7+7+7, 7+9+12</td> </tr> <tr> <td>9</td> <td>7+9, 9+18</td> <td>7+7+9, 7+12+12</td> </tr> <tr> <td>12</td> <td>7+12, 12+12</td> <td>7+7+12, 9+9+9</td> </tr> <tr> <td>18</td> <td>7+18, 12+18</td> <td>7+7+18, 9+9+12</td> </tr> <tr> <td></td> <td>9+9</td> <td>7+9+9, 9+12+12</td> </tr> </tbody> </table>	One Unit	Two Units	Three Units	7	7+7, 9+12	7+7+7, 7+9+12	9	7+9, 9+18	7+7+9, 7+12+12	12	7+12, 12+12	7+7+12, 9+9+9	18	7+18, 12+18	7+7+18, 9+9+12		9+9	7+9+9, 9+12+12							
		One Unit	Two Units	Three Units																							
7	7+7, 9+12	7+7+7, 7+9+12																									
9	7+9, 9+18	7+7+9, 7+12+12																									
12	7+12, 12+12	7+7+12, 9+9+9																									
18	7+18, 12+18	7+7+18, 9+9+12																									
	9+9	7+9+9, 9+12+12																									
<b>1 drive 4</b> KMF36H-4VR1	Wall mounted: 7k/9k/12k/18k/24k 4-way Cassette: 9k/12k/18k/24k Ceiling Floor: 9k/12k/18k/24k Slim Duct: 7k/9k/12k/18k/24k	<table border="1"> <thead> <tr> <th>One Unit</th> <th>Two Units</th> <th>Three Units</th> <th>Four Units</th> </tr> </thead> <tbody> <tr> <td>7</td> <td>7+12, 12+12</td> <td>7+7+9, 7+9+18, 9+9+12, 9+12+24</td> <td>7+7+7+7, 7+7+9+9, 7+9+9+9, 9+9+9+12</td> </tr> <tr> <td>9</td> <td>7+18, 12+18</td> <td>7+7+12, 7+9+24, 9+9+18, 12+12+12</td> <td>7+7+7+9, 7+7+9+12, 7+9+9+12, 9+9+12+12</td> </tr> <tr> <td>12</td> <td>7+24, 12+24</td> <td>7+7+18, 7+12+12, 9+9+24, 12+12+18</td> <td>7+7+7+12, 7+7+9+18, 7+9+9+18, 9+9+12+18</td> </tr> <tr> <td>18</td> <td>9+18, 18+18</td> <td>7+7+24, 7+12+18, 9+12+12, 12+12+24</td> <td>7+7+7+18, 7+7+12+12, 7+9+12+12, 9+12+12+12</td> </tr> <tr> <td>24</td> <td>9+24, 18+24</td> <td>7+9+12, 7+12+24, 9+12+18, 12+18+18</td> <td>7+7+7+24, 7+7+12+18, 7+12+12+12, 12+12+12+12</td> </tr> </tbody> </table>	One Unit	Two Units	Three Units	Four Units	7	7+12, 12+12	7+7+9, 7+9+18, 9+9+12, 9+12+24	7+7+7+7, 7+7+9+9, 7+9+9+9, 9+9+9+12	9	7+18, 12+18	7+7+12, 7+9+24, 9+9+18, 12+12+12	7+7+7+9, 7+7+9+12, 7+9+9+12, 9+9+12+12	12	7+24, 12+24	7+7+18, 7+12+12, 9+9+24, 12+12+18	7+7+7+12, 7+7+9+18, 7+9+9+18, 9+9+12+18	18	9+18, 18+18	7+7+24, 7+12+18, 9+12+12, 12+12+24	7+7+7+18, 7+7+12+12, 7+9+12+12, 9+12+12+12	24	9+24, 18+24	7+9+12, 7+12+24, 9+12+18, 12+18+18	7+7+7+24, 7+7+12+18, 7+12+12+12, 12+12+12+12	
		One Unit	Two Units	Three Units	Four Units																						
7	7+12, 12+12	7+7+9, 7+9+18, 9+9+12, 9+12+24	7+7+7+7, 7+7+9+9, 7+9+9+9, 9+9+9+12																								
9	7+18, 12+18	7+7+12, 7+9+24, 9+9+18, 12+12+12	7+7+7+9, 7+7+9+12, 7+9+9+12, 9+9+12+12																								
12	7+24, 12+24	7+7+18, 7+12+12, 9+9+24, 12+12+18	7+7+7+12, 7+7+9+18, 7+9+9+18, 9+9+12+18																								
18	9+18, 18+18	7+7+24, 7+12+18, 9+12+12, 12+12+24	7+7+7+18, 7+7+12+12, 7+9+12+12, 9+12+12+12																								
24	9+24, 18+24	7+9+12, 7+12+24, 9+12+18, 12+18+18	7+7+7+24, 7+7+12+18, 7+12+12+12, 12+12+12+12																								
<b>1 drive 5</b> KMV42H-4VR1	Wall mounted: 7k/9k/12k/18k/24k 4-way Cassette: 9k/12k/18k/24k Ceiling Floor: 9k/12k/18k/24k Slim Duct: 7k/9k/12k/18k/24k	<table border="1"> <thead> <tr> <th>Three Units</th> <th>Four Units</th> <th>Five Units</th> </tr> </thead> <tbody> <tr> <td>7+7+12, 7+9+24, 9+9+24, 12+12+18</td> <td>7+7+7+7, 7+7+9+9, 7+9+9+12, 9+9+9+12, 9+12+12+12</td> <td>7+7+7+7+7, 7+7+7+9+9, 7+7+7+12+18, 7+7+9+9+24</td> </tr> <tr> <td>7+7+18, 7+12+18, 9+12+12, 12+12+24</td> <td>7+7+7+9, 7+7+9+12, 7+9+9+18, 9+9+9+24, 9+12+12+18</td> <td>7+7+7+7+9, 7+7+7+9+12, 7+7+7+12+18, 7+7+9+9+9</td> </tr> <tr> <td>7+7+24, 7+12+24, 9+12+18, 12+18+18</td> <td>7+7+7+12, 7+7+9+18, 7+9+9+24, 9+9+9+24, 9+12+12+24</td> <td>7+7+7+7+12, 7+7+7+9+18, 7+7+9+9+18, 7+7+9+9+12</td> </tr> <tr> <td>7+9+12, 9+9+12, 9+12+24, 12+18+24</td> <td>7+7+7+18, 7+7+12+12, 7+9+12+12, 9+9+12+12, 12+12+12+12</td> <td>7+7+7+7+18, 7+7+7+9+24, 7+7+9+9+18, 9+9+9+9+18</td> </tr> <tr> <td>7+9+18, 9+9+18, 12+12+12, 18+18+18</td> <td>7+7+7+24, 7+7+12+18, 7+12+12+12, 9+9+12+18, 12+12+12+18</td> <td>7+7+7+7+24, 7+7+7+12+12, 7+7+9+9+18, 9+9+9+12+18</td> </tr> </tbody> </table>	Three Units	Four Units	Five Units	7+7+12, 7+9+24, 9+9+24, 12+12+18	7+7+7+7, 7+7+9+9, 7+9+9+12, 9+9+9+12, 9+12+12+12	7+7+7+7+7, 7+7+7+9+9, 7+7+7+12+18, 7+7+9+9+24	7+7+18, 7+12+18, 9+12+12, 12+12+24	7+7+7+9, 7+7+9+12, 7+9+9+18, 9+9+9+24, 9+12+12+18	7+7+7+7+9, 7+7+7+9+12, 7+7+7+12+18, 7+7+9+9+9	7+7+24, 7+12+24, 9+12+18, 12+18+18	7+7+7+12, 7+7+9+18, 7+9+9+24, 9+9+9+24, 9+12+12+24	7+7+7+7+12, 7+7+7+9+18, 7+7+9+9+18, 7+7+9+9+12	7+9+12, 9+9+12, 9+12+24, 12+18+24	7+7+7+18, 7+7+12+12, 7+9+12+12, 9+9+12+12, 12+12+12+12	7+7+7+7+18, 7+7+7+9+24, 7+7+9+9+18, 9+9+9+9+18	7+9+18, 9+9+18, 12+12+12, 18+18+18	7+7+7+24, 7+7+12+18, 7+12+12+12, 9+9+12+18, 12+12+12+18	7+7+7+7+24, 7+7+7+12+12, 7+7+9+9+18, 9+9+9+12+18							
		Three Units	Four Units	Five Units																							
7+7+12, 7+9+24, 9+9+24, 12+12+18	7+7+7+7, 7+7+9+9, 7+9+9+12, 9+9+9+12, 9+12+12+12	7+7+7+7+7, 7+7+7+9+9, 7+7+7+12+18, 7+7+9+9+24																									
7+7+18, 7+12+18, 9+12+12, 12+12+24	7+7+7+9, 7+7+9+12, 7+9+9+18, 9+9+9+24, 9+12+12+18	7+7+7+7+9, 7+7+7+9+12, 7+7+7+12+18, 7+7+9+9+9																									
7+7+24, 7+12+24, 9+12+18, 12+18+18	7+7+7+12, 7+7+9+18, 7+9+9+24, 9+9+9+24, 9+12+12+24	7+7+7+7+12, 7+7+7+9+18, 7+7+9+9+18, 7+7+9+9+12																									
7+9+12, 9+9+12, 9+12+24, 12+18+24	7+7+7+18, 7+7+12+12, 7+9+12+12, 9+9+12+12, 12+12+12+12	7+7+7+7+18, 7+7+7+9+24, 7+7+9+9+18, 9+9+9+9+18																									
7+9+18, 9+9+18, 12+12+12, 18+18+18	7+7+7+24, 7+7+12+18, 7+12+12+12, 9+9+12+18, 12+12+12+18	7+7+7+7+24, 7+7+7+12+12, 7+7+9+9+18, 9+9+9+12+18																									





## Free Match-Indoor Units

### Specification-Ceiling&Floor



Model	Indoor unit		KMNE09H-4VR1	KMNE12H-4VR1	KMNE18H-4VR1	
Capacity	Cooling/Heating	Btu/h	9560(5120-12115)/10240(5460-13000)	12285(5800-12625)/14670(6930-15080)	17400(8530-19780)/24570(11840-27415)	
		kW	2.80(1.50-3.55)/3.00(1.60-3.81)	3.60(1.70-3.70)/3.90(2.03-4.42)	5.30(2.50-5.80)/5.80(3.47-8.04)	
Electric Data	Power Supply	V-,Hz,Ph	220-240,50,1	220-240,50,1	220-240,50,1	
		Cooling/Heating Power Input	W	80(20-125)/80(20-125)	80(20-125)/80(20-125)	80(20-125)/80(20-125)
Performance	Air Flow Volume	m <sup>3</sup> /h	620	620	850	
		Noise Level	dB(A)	39/36/30	39/36/30	43/39/36
Dimension (WxDxH)	Net	mm	929 × 660 × 205	929 × 660 × 205	929 × 660 × 205	
		Packing	mm	1010 × 720 × 290	1010 × 720 × 290	1010 × 720 × 290
			Weight	Net/Gross	kg	24/27
Piping size	Liquid Side	mm(inch)	6.35(1/4)	6.35(1/4)	6.35(1/4)	
		Gas Side	mm(inch)	12.7(1/2)	12.7(1/2)	12.7(1/2)
			Drainage	mm(inch)	DN20(R3/4)	DN20(R3/4)
Stuffing Quantity	20/40/40H	unit	136/280/315	136/280/315	136/280/315	

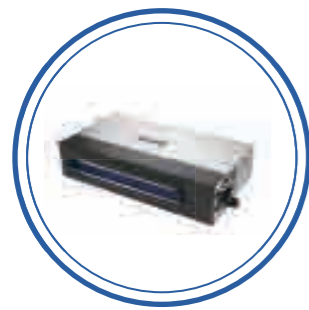

## Free Match-Indoor Units

### Specification-Slim Duct



Model	Indoor unit		KMNS07H-4VR1	KMNS09H-4VR1	KMNS12H-4VR1	KMNS18H-4VR1	
Capacity	Cooling/Heating	Btu/h	7506(3855-9220)/8530(4575-10820)	9560(5120-12115)/10236(5800-12450)	12280(5835-13135)/12965(6480-13375)	19110(8530-19790)/20470(9690-21835)	
		kW	2.20(1.13-2.70)/2.50(1.34-3.17)	2.80(1.50-3.55)/2.90(1.70-3.65)	3.60(1.71-3.85)/4.00(1.90-3.92)	5.10(2.50-5.80)/5.80(2.84-6.40)	
Electric Data	Power Supply	V-,Hz,Ph	220-240,50,1	220-240,50,1	220-240,50,1	220-240,50,1	
		Cooling/Heating Power Input	W	45/45	45/45	75/75	137/137
Performance	Air Flow Volume	m <sup>3</sup> /h	420	420	580	860	
		Noise Level	dB(A)	30/26/23	30/26/23	32/28/25	38/35/32
Dimension (WxDxH)	ESP	Pa	10/30	10/30	10/30	10/30	
		Net	mm	840 × 460 × 185	840 × 460 × 185	840 × 460 × 185	1110 × 547 × 240
			Packing	mm	1030 × 545 × 250	1030 × 545 × 250	1030 × 545 × 250
Weight	Net/Gross	kg	16.5/20	16.5/20	17.5/21	21/26	
		Liquid Side	mm(inch)	6.35(1/4)	6.35(1/4)	6.35(1/4)	6.35(1/4)
			Gas Side	mm(inch)	9.52(3/8)	9.52(3/8)	12.7(1/2)
Drainage	mm(inch)	16.5(3/5)		16.5(3/5)	16.5(3/5)	16.5(3/5)	
Stuffing Quantity	20/40/40H	unit	198/396/440	198/396/440	198/396/440	144/297/330	

\* Remark: The above designs and specifications are subject to change without prior notice. Final specifications please refer to technical specification provided by sales representative.

# Tropical 50Hz&60Hz





# Tropical- Outdoor Units



## Environment Friendly-R410a



## Up To 55°C Running

Enjoy excellent performance even under ambient temperature up to 55°C , suitable for T3 operating condition.

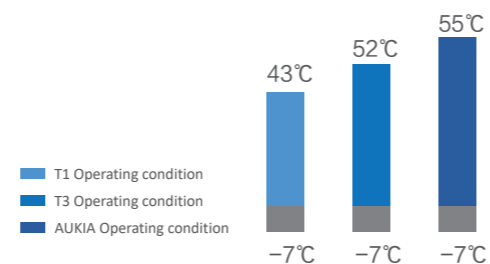

## Multiple Protection

With Multiple Protection contents: High pressure protection, Low pressure protection, Compressor overloading protection, High Ext. temperature protection, Phase protection (Phase-loss, phase-reverse), Over-heating protection, Anti-freezing protection, Sensor failure alarm, Failure code display, etc. The compressor could well run in reasonable operation range.

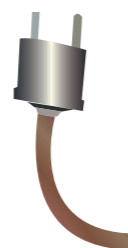

## Double Anti-Corrosion Technology

Galvanized metal with world-class powder spraying technology can improve the anti-corrosion ability of the housing of outdoor units three times, especially, in salty, moist surroundings.



# Outdoor Units

## Specification-T3 R410a 60Hz



Model	Outdoor		KOUT18C-2R1A	KOUT24C-2R1A	KOUT36C-2R1A	KOUT48C-2R1A	KOUT60C-2R1A
Electric Data	Power Supply	V-,Hz,Ph	220-240,60,1	220-240,60,1	220-240,60,1	220-240,60,1	220-240,60,1
	Air Flow Volume	m <sup>3</sup> /h	2800	3200	6400	6400	6400
Performance		CFM	1647	1882	3765	3765	3765
	Noise Level	dB(A)	56	59	58	60	60
Dimension	Net	mm	822×302×655	888×318×699	940×368×1366	940×368×1366	940×368×1366
	(WxDxH) Packing	mm	945×430×725	1020×430×770	1080×460×1500	1080×460×1500	1080×460×1500
Weight	Net/Gross	kg	46/49.5	52/55	82/98	105/121	105/121
	Liquid	mm(inch)	6.35(1/4)	9.52(3/8)	9.52(3/8)	9.52(3/8)	9.52(3/8)
Piping	Gas	mm (inch)	12.70(1/2)	15.88(5/8)	19.05(3/4)	19.05(3/4)	19.05(3/4)
	Max.Length/Max.Height	m	50/15	50/15	50/30	50/30	50/30
Stuffing Quantity	20/40/40H	unit	96/198/198	87/183/183	27/55/55	27/55/55	27/55/55

## Specification-T3 R410a 60Hz



Model	Outdoor		KOUT18H-2R1A	KOUT24H-2R1A	KOUT36H-2R1A	KOUT48H-2R1A	KOUT60H-2R1A
Electric Data	Power Supply	V-,Hz,Ph	220-240,60,1	220-240,60,1	220-240,60,1	220-240,60,1	220-240,60,1
	Air Flow Volume	m <sup>3</sup> /h	2800	3200	6400	6400	6400
Performance		CFM	1647	1882	3765	3765	3765
	Noise Level	dB(A)	56	59	58	60	60
Dimension	Net	mm	822×302×655	888×318×699	940×368×1366	940×368×1366	940×368×1366
	(WxDxH) Packing	mm	945×430×725	1020×430×770	1080×460×1500	1080×460×1500	1080×460×1500
Weight	Net/Gross	kg	46/49.5	52/55	82/98	105/121	105/121
	Liquid	mm(inch)	6.35(1/4)	9.52(3/8)	9.52(3/8)	9.52(3/8)	9.52(3/8)
Piping	Gas	mm (inch)	12.70(1/2)	15.88(5/8)	19.05(3/4)	19.05(3/4)	19.05(3/4)
	Max.Length/Max.Height	m	50/15	50/15	50/30	50/30	50/30
Stuffing Quantity	20/40/40H	unit	96/198/198	87/183/183	27/55/55	27/55/55	27/55/55

★ Remark:

- The above designs and specifications are subject to change without prior notice. Final specifications please refer to technical specification provided by sales representative.
- Cooling Capacity and Cooling Input Power (T1): Indoor Temperature 26.7°C DB/19.4°C WB; Ambient Temperature 35°C DB/24°C WB.
- Cooling Capacity and Cooling Input Power (T3): Indoor Temperature 26.7°C DB/19.4°C WB; Ambient Temperature 46.1°C DB.
- The Max.Ambient temperature for units running is 55°C .



## Outdoor Units

### Specification-T3 R410a 50Hz



Model	Outdoor		KOUT18C-4R1EA	KOUT24C-4R1EA	KOUT30C-4R1EA	KOUT36C-4R1EA	KOUT48C-4R1EA	KOUT60C-4R1EA
Electric Data	Power Supply	V~,Hz,Ph	220-240,50,1	220-240,50,1	220-240,50,1	220-240,50,1	380-415,50,3	380-415,50,3
	Air Flow Volume	m <sup>3</sup> /h	2600	3200	3200	5200	6400	6400
Performance		CFM	1529	1882	1882	3059	3765	3765
	Noise Level	dB(A)	56	58	58	58	60	60
Dimension (WxDxH)	Net	mm	800×286×530	888×318×699	888×318×699	940×368×1366	940×368×1366	940×368×1366
	Packing	mm	920×400×620	1020×430×770	1020×430×770	1080×460×1500	1080×460×1500	1080×460×1500
Weight	Net/Gross	kg	39/42	49/53	56/60	94/110	104/120	105/121
	Liquid	mm(inch)	6.35(1/4)	9.52(3/8)	9.52(3/8)	9.52(3/8)	9.52(3/8)	9.52(3/8)
Piping	Gas	mm (inch)	12.7(1/2)	15.88(5/8)	15.88(5/8)	19.05(3/4)	19.05(3/4)	19.05(3/4)
	Max. Length/Max. Height	m	30/15	30/15	30/15	50/30	50/30	50/30
Stuffing Quantity	20/40/40H	unit	102/219/292	87/183/183	87/183/183	27/55/55	27/55/55	27/55/55

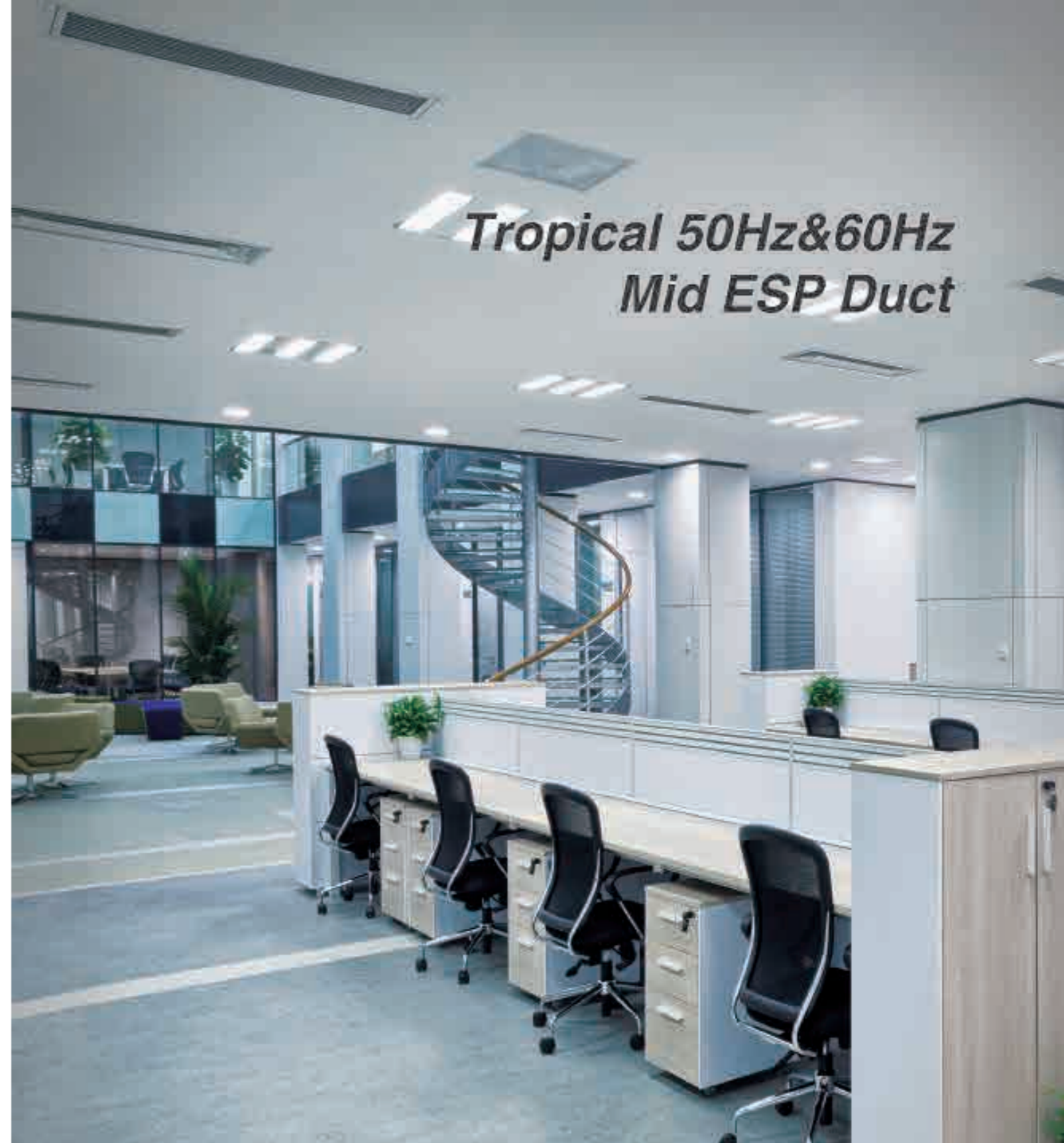

## Tropical 50Hz&60Hz Mid ESP Duct

### FEATURES

■ optional ■ standard

- Wired Control
- 3D Air Flow
- Auto Restart Function
- Long-term Filter
- Hydrophilic Aluminum Fin
- Intelligent Defrosting
- Fast Cooling/Heating
- Low Ambient Cooling
- Remote control
- Central Control
- Golden Fin
- WiFi Control

★ Remark:  
 1.The above designs and specifications are subject to change without prior notice. Final specifications please refer to technical specification provided by sales representative.  
 2.Cooling Capacity and Cooling Input Power (T1):Indoor Temperature 26.7°C DB/19.4°C WB;Ambient Temperature 35°C DB/24°C WB.  
 3.Cooling Capacity and Cooling Input Power (T3):Indoor Temperature 26.7°C DB/19.4°C WB;Ambient Temperature 46.1°C DB.  
 4.The Max.Ambient temperature for units running is 55 °C .

# Tropical-Mid ESP Duct

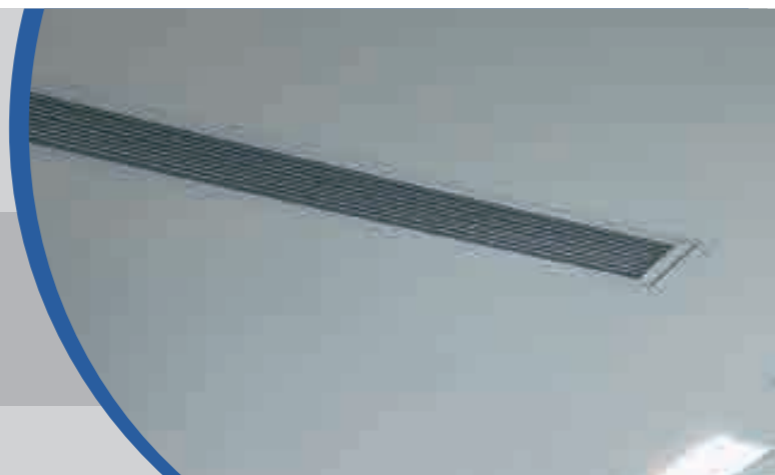
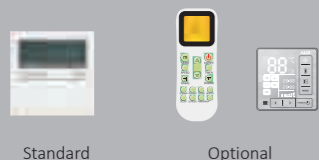

## Wifi Control

The optional WiFi modular makes it possible to monitor and control your AC while on the road through APP on your mobile phone or pad.



## Fresh Air Intake

Fresh air makes healthy, comfortable life.



## Built-in Water Pump (Optional)

The built-in pump can lift condensing water up to 1200mm high from the drainage pan.

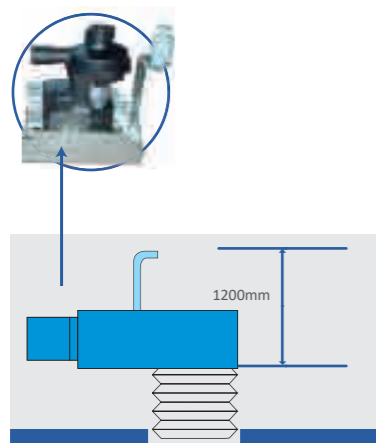

## Flexible Air Intake Options

Air intake from rear as standard, from bottom is optional.

The size of the plate from bottom is the same as the flange from back, which makes it convenient to change installation style due to different decoration requirements.

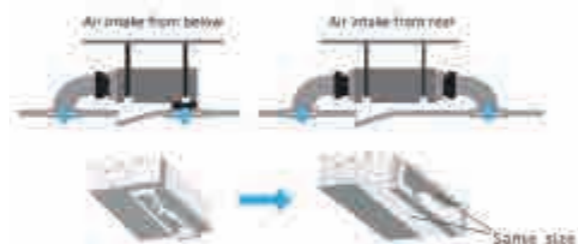

## Mid ESP Duct

### Specification-T3 R410a 60Hz



Model	Indoor		KNLT18C-2R1A	KNLT24C-2R1A	KNMT36C-2R1A	KNMT48C-2R1A	KNMT60C-2R1A
	Outdoor		KOUT18C-2R1A	KOUT24C-2R1A	KOUT36C-2R1A	KOUT48C-2R1A	KOUT60C-2R1A
Capacity	Cooling (T1/T3)	Btu/h	17500/15000	22000/19000	32000/28000	46000/40000	54000/47000
		RT	1.46/1.25	1.83/1.58	2.67/2.33	3.83/3.33	4.50/3.92
		kW	5.13/4.40	6.45/5.57	9.38/8.21	13.48/11.72	15.83/13.77
Electric Data	Power Supply	V~,Hz,Ph	220-240,60,1	220-240,60,1	220-240,60,1	220-240,60,1	220-240,60,1
	Cooling Power Input(T1/T3)	kW	1.45/1.72	1.78/2.18	2.60/3.11	3.79/4.57	4.60/5.43
Performance	Air Flow Volume(Hi/Mid/Low)	m³/h	1100/1000/900	1500/1350/1200	1800/1600/1400	2400/2100/1800	3000/2700/2300
		CFM	647/588/529	882/794/706	1059/941/823	1412/1235/1059	1764/1588/1353
Dimension (WxDxH)	Net	mm	890 × 735 × 290	890 × 735 × 290	1250 × 735 × 290	1250 × 735 × 320	1400 × 820 × 380
		Packing	mm	1070 × 800 × 360	1070 × 800 × 360	1430 × 800 × 360	1430 × 800 × 390
Weight	Net/Gross	kg	32/35.5	33/36.5	44/50	47/53	51.5/58.5
Piping Size	Drainage	mm(inch)	DN20(R3/4)	DN20(R3/4)	DN20(R3/4)	DN20(R3/4)	DN20(R3/4)
Stuffing Quantity	20/40/40H	set	40/84/106	40/84/102	21/42/49	21/42/47	18/37/40

### Specification-T3 R410a 60Hz



Model	Indoor		KNLT18H-2R1A	KNLT24H-2R1A	KNMT36H-2R1A	KNMT48H-2R1A	KNMT60H-2R1A
	Outdoor		KOUT18H-2R1A	KOUT24H-2R1A	KOUT36H-2R1A	KOUT48H-2R1A	KOUT60H-2R1A
Capacity	Cooling (T1/T3)	Btu/h	17500/15000	22000/19000	32000/28000	46000/40000	54000/47000
		RT	1.46/1.25	1.83/1.58	2.67/2.33	3.83/3.33	4.50/3.92
		kW	5.13/4.40	6.45/5.57	9.38/8.21	13.48/11.72	15.83/13.77
Electric Data	Power Supply	V~,Hz,Ph	220-240,60,1	220-240,60,1	220-240,60,1	220-240,60,1	220-240,60,1
	Cooling Power Input(T1/T3)	kW	1.45/1.72	1.78/2.18	2.60/3.11	3.79/4.57	4.60/5.43
Performance	Air Flow Volume(Hi/Mid/Low)	m³/h	1100/1000/900	1500/1350/1200	1800/1600/1400	2400/2100/1800	3000/2700/2300
		CFM	647/588/529	882/794/706	1059/941/823	1412/1235/1059	1764/1588/1353
Dimension (WxDxH)	Net	mm	890 × 735 × 290	890 × 735 × 290	1250 × 735 × 290	1250 × 735 × 320	1400 × 820 × 380
		Packing	mm	1070 × 800 × 360	1070 × 800 × 360	1430 × 800 × 360	1430 × 800 × 390
Weight	Net/Gross	kg	32/35.5	33/36.5	44/50	47/53	51.5/58.5
Piping Size	Drainage	mm(inch)	DN20(R3/4)	DN20(R3/4)	DN20(R3/4)	DN20(R3/4)	DN20(R3/4)
Stuffing Quantity	20/40/40H	set	40/84/106	40/84/102	21/42/49	21/42/47	18/37/40

\* Remark:  
 1.The above designs and specifications are subject to change without prior notice. Final specifications please refer to technical specification provided by sales representative.  
 2.Cooling Capacity and Cooling Input Power (T1):Indoor Temperature 26.7°C DB/19.4°C WB;Ambient Temperature 35°C DB/24°C WB.  
 3.Cooling Capacity and Cooling Input Power (T3):Indoor Temperature 26.7°C DB/19.4°C WB;Ambient Temperature 46.1°C DB.  
 4.The Max.Ambient temperature for units running is 55 °C .



## Mid ESP Duct

### Specification-T3 R410a 50Hz



Model	Indoor		KNMT18C-4R1EA	KNMT24C-4R1EA	KNMT30C-4R1EA
	Outdoor		KOUT18C-4R1EA	KOUT24C-4R1EA	KOUT30C-4R1EA
Capacity	Cooling (T1/T3)	Btu/h	17500/15200	23500/20500	28000/24500
		RT	1.46/1.27	1.96/1.71	2.33/2.04
		kW	5.13/4.45	6.89/6.01	8.21/7.18
Electric Data	Power Supply	V-,Hz,Ph	220-240,50,1	220-240,50,1	220-240,50,1
	Cooling Power Input(T1/T3)	kW	1.48/1.78	1.96/2.35	2.40/2.90
	Cooling Current(T1/T3)	A	6.55/7.85	8.68/10.33	10.72/12.85
Performance	EER(T1/T3)	(Btu/h)/W	11.824/8.539	11.990/8.723	11.667/8.448
		W/W	3.465/2.503	3.514/2.557	3.419/2.476
	Air Flow Volume(Hi/Mid/Low)	m <sup>3</sup> /h	1000/800/700	1400/1250/1050	1650/1450/1250
		CFM	587/470/411	822/734/616	969/851/734
	Noise Level(Hi/Mid/Low)	dB(A)	43/41/40	45/43/41	45/41/39
	External Static Pressure(ESP)	Pa	0 ~ 60	0 ~ 60	0 ~ 80
Dimension (WxDxH)	Net	mm	890 × 735 × 290	890 × 735 × 290	1250 × 735 × 290
	Packing	mm	1070 × 800 × 360	1070 × 800 × 360	1430 × 800 × 360
Weight	Net/Gross	kg	32/35.5	33/36.5	44/50
Piping Size	Drainage	mm(inch)	DN20(R3/4)	DN20(R3/4)	DN20(R3/4)
Stuffing Quantity	20/40/40H	set	84/168/196	84/168/196	32/70/79

### Specification-T3 R410a 50Hz



Model	Indoor		KNMT36C-4R1EA	KNMT48C-4R1EA	KNMT60C-4R1EA
	Outdoor		KOUT36C-4R1EA	KOUT48C-4R1EA	KOUT60C-4R1EA
Capacity	Cooling (T1/T3)	Btu/h	34500/30500	48000/42000	52000/45500
		RT	2.88/2.54	4.00/3.50	4.33/3.79
		kW	10.11/8.94	14.07/12.31	15.24/13.33
Electric Data	Power Supply	V-,Hz,Ph	220-240,50,1	380-415,50,3	380-415,50,3
	Cooling Power Input(T1/T3)	kW	2.88/3.50	4.00/4.80	4.40/5.23
	Cooling Current(T1/T3)	A	12.75/15.50	6.70/8.10	7.40/8.80
Performance	EER(T1/T3)	(Btu/h)/W	11.979/8.714	12.000/8.750	11.818/8.700
		W/W	3.511/2.554	3.517/2.564	3.464/2.550
	Air Flow Volume(Hi/Mid/Low)	m <sup>3</sup> /h	2200/1850/1600	2600/2300/1950	3100/2600/2200
		CFM	1291/1086/939	1526/1350/1145	1820/1526/1291
	Noise Level(Hi/Mid/Low)	dB(A)	47/43/40	49/45/43	53/50/47
	External Static Pressure(ESP)	Pa	0 ~ 80	0 ~ 100	0 ~ 150
Dimension (WxDxH)	Net	mm	1250 × 735 × 290	1250 × 735 × 320	1400 × 820 × 380
	Packing	mm	1430 × 800 × 360	1430 × 800 × 390	1580 × 880 × 450
Weight	Net/Gross	kg	44/50	47/53	51.5/58.5
Piping Size	Drainage	mm(inch)	DN20(R3/4)	DN20(R3/4)	DN20(R3/4)
Stuffing Quantity	20/40/40H	set	21/42/49	21/42/46	17/34/38

★ Remark:  
 1.The above designs and specifications are subject to change without prior notice. Final specifications please refer to technical specification provided by sales representative.  
 2.Cooling Capacity and Cooling Input Power (T1):Indoor Temperature 26.7°C DB/19.4°C WB;Ambient Temperature 35°C DB/24°C WB.  
 3.Cooling Capacity and Cooling Input Power (T3):Indoor Temperature 26.7°C DB/19.4°C WB;Ambient Temperature 46.1°C DB.  
 4.The Max.Ambient temperature for units running is 55 °C.

## Tropical 50Hz&60Hz Four-way Cassette

### FEATURES

- 24-hour Timer
- Built-in Drain Pump
- Auto Restart Function
- Digital Tube Display
- Sleep Mode
- Independent Dehumidification
- Silent
- Anti-Cold Air
- Self-diagnosis Function
- Low Ambient Cooling
- Long-term Filter
- Intelligent Defrosting
- Wired Control
- Central Control
- Fresh Air Intake
- WiFi Control

■ optional ■ standard

# Tropical-Four-Way Cassette

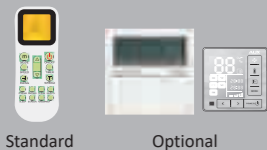

## Wifi Control

The optional WiFi modular makes it possible to monitor and control your AC while on the road through APP on your mobile phone or pad.



## Built-in Water Drainage Pump

The built-in pump can lift condensing water up to 1200mm high from the drainage pan.

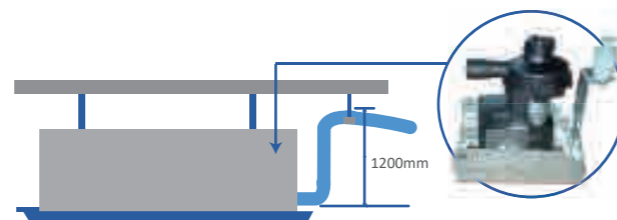

## Fresh Air Intake

Fresh air makes indoor air healthy and comfortable.



Fresh air intake

## Long Term Filter

The long-term air filter ensures better air quality and decreases the cleaning frequency.

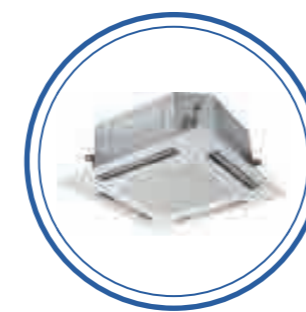
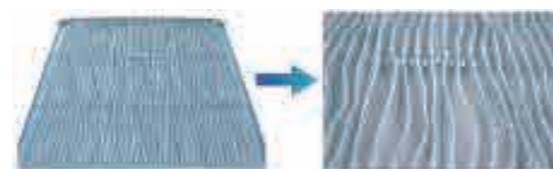

## Four-Way Cassette

### Specification-T3 R410a 60Hz



Model	Indoor		KNCT18C-2R1A	KNCT24C-2R1A	KNCT36C-2R1A	KNCT48C-2R1A	
	Outdoor		KOUT18C-2R1A	KOUT24C-2R1A	KOUT36C-2R1A	KOUT48C-2R1A	
Capacity	Cooling (T1/T3)	Btu/h	17500/15000	22000/19000	32000/28000	44000/38200	
		RT	1.46/1.25	1.83/1.58	2.67/2.33	3.67/3.18	
		kW	5.13/4.40	6.45/5.57	9.38/8.21	12.90/11.20	
Electric Data	Power Supply	V~,Hz,Ph	220-240,60,1	220-240,60,1	220-240,60,1	220-240,60,1	
		Cooling Power Input (T1/T3)	kW	1.45/1.72	1.78/2.18	2.60/3.11	3.73/4.52
		Cooling Current (T1/T3)	A	6.40/7.70	8.00/9.50	11.70/13.90	16.60/19.80
Performance	EER(T1/T3)	(Btu/h)/W	12.069/8.721	12.360/8.716	12.308/9.003	11.796/8.451	
		WW	3.538/2.558	3.624/2.555	3.608/2.640	3.458/2.478	
	Air Flow Volume(Hi/Mid/Low)	m <sup>3</sup> /h	1000/850/700	1500/1200/1050	1850/1650/1450	2100/1900/1700	
		CFM	588/500/412	882/705/617	1088/972/853	1235/1117/1000	
	Noise Level(Hi/Mid/Low)	dB(A)	43/40/38	48/43/41	54/48/45	55/51/48	
Dimension (WxDxH)	Net(Body)	mm	835 × 835 × 250	835 × 835 × 250	835 × 835 × 290	835 × 835 × 290	
	Packing(Body)	mm	910 × 910 × 310	910 × 910 × 310	910 × 910 × 350	910 × 910 × 350	
	Net(Panel)	mm	950 × 950 × 55	950 × 950 × 55	950 × 950 × 55	950 × 950 × 55	
	Packing(Panel)	mm	1000 × 1000 × 100	1000 × 1000 × 100	1000 × 1000 × 100	1000 × 1000 × 100	
Weight	Net(Body)/Gross(Body)	kg	24/27.5	25/28.5	31/35	31/35	
	Net(Panel)/Gross(Panel)	kg	5/7	5/7	5/7	5/7	
Piping Size	Drainage	mm(inch)	DN20(R3/4)	DN20(R3/4)	DN20(R3/4)	DN20(R3/4)	
Stuffing Quantity		set	40/87/100	42/82/92	22/48/54	22/50/55	

### Specification-T3 R410a 60Hz



Model	Indoor		KNCT18H-2R1A	KNCT24H-2R1A	KNCT36H-2R1A	KNCT48H-2R1A	
	Outdoor		KOUT18H-2R1A	KOUT24H-2R1A	KOUT36H-2R1A	KOUT48H-2R1A	
Capacity	Cooling (T1/T3)	Btu/h	17500/15000	22000/19000	32000/28000	44000/38200	
		RT	1.46/1.25	1.83/1.58	2.67/2.33	3.67/3.18	
	Heating(T1)	Btu/h	17500	22000	34000	48000	
		RT	1.46	1.83	2.83	4	
Electric Data	Power Supply	V~,Hz,Ph	220-240,60,1	220-240,60,1	220-240,60,1	220-240,60,1	
		Cooling Power Input(T1/T3)	kW	1.45/1.72	1.78/2.18	2.60/3.11	3.73/4.52
		Cooling Current(T1/T3)	A	6.40/7.70	8.00/9.50	11.70/13.90	16.60/19.80
Performance	EER(T1/T3)	(Btu/h)/W	12.069/8.721	12.360/8.716	12.308/9.003	11.796/8.451	
		WW	3.538/2.558	3.624/2.555	3.608/2.640	3.458/2.478	
	COP(T1)	(Btu/h)/W	12.868	13.333	12.977	11.852	
		WW	3.772	3.909	3.802	3.474	
	Air Flow Volume(Hi/Mid/Low)	m <sup>3</sup> /h	1000/850/700	1500/1200/1050	1850/1650/1450	2100/1900/1700	
Noise Level(Hi/Mid/Low)	dB(A)	43/40/38	48/43/41	54/48/45	55/51/48		
Dimension (WxDxH)	Net(Body)	mm	835 × 835 × 250	835 × 835 × 250	835 × 835 × 290	835 × 835 × 290	
	Packing(Body)	mm	910 × 910 × 310	910 × 910 × 310	910 × 910 × 350	910 × 910 × 350	
	Net(Panel)	mm	950 × 950 × 55	950 × 950 × 55	950 × 950 × 55	950 × 950 × 55	
	Packing(Panel)	mm	1000 × 1000 × 100	1000 × 1000 × 100	1000 × 1000 × 100	1000 × 1000 × 100	
Weight	Net(Body)/Gross(Body)	kg	24/27.5	25/28.5	31/35	31/35	
	Net(Panel)/Gross(Panel)	kg	5/7	5/7	5/7	5/7	
Piping Size	Drainage	mm(inch)	DN20(R3/4)	DN20(R3/4)	DN20(R3/4)	DN20(R3/4)	
Stuffing Quantity		set	40/87/100	42/82/92	22/48/54	22/50/55	

★ Remark:

- 1.The above designs and specifications are subject to change without prior notice. Final specifications please refer to technical specification provided by sales representative.
- 2.Cooling Capacity and Cooling Input Power (T1):Indoor Temperature 26.7°C DB/19.4°C WB;Ambient Temperature 35°C DB/24°C WB.
- 3.Cooling Capacity and Cooling Input Power (T3):Indoor Temperature 26.7°C DB/19.4°C WB;Ambient Temperature 46.1°C DB.
- 4.The Max.Ambient temperature for units running is 55°C.

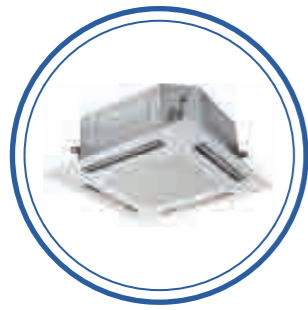

## Four-Way Cassette

### Specification-T3 R410a 50Hz



Model	Indoor		KNCT18C-4R1EA	KNCT24C-4R1EA	KNCT30C-4R1EA	KNCT36C-4R1EA	KNCT48C-4R1EA
	Outdoor		KOUT18C-4R1EA	KOUT24C-4R1EA	KOUT30C-4R1EA	KOUT36C-4R1EA	KOUT48C-4R1EA
Capacity	Cooling (T1/T3)	Btu/h	17500/15200	23500/20500	28000/24500	32500/29200	44500/38300
		RT	1.46/1.27	1.96/1.71	2.33/2.04	2.71/2.43	3.81/3.19
Electric Data	Cooling Power Input (T1/T3)	kW	5.13/4.45	6.89/6.01	8.21/7.18	9.52/8.56	13.04/11.22
		Power Supply	V~,Hz,Ph	220-240,50,1	220-240,50,1	220-240,50,1	220-240,50,1
Performance	Cooling Current (T1/T3)	A	6.55/7.85	8.68/10.33	10.72/12.85	12.30/15.15	6.35/7.65
		EER (T1/T3)	(Btu/h)/W	11.824/8.539	11.990/8.723	11.667/8.448	11.691/8.538
	Air Flow Volume(Hi/Mid/Low)	W/W	3.465/2.503	3.514/2.557	3.419/2.476	3.426/2.502	3.432/2.451
		m <sup>3</sup> /h	1000/800/670	1400/1100/950	1650/1300/1100	1800/1450/1250	2000/1800/1600
Noise Level(Hi/Mid/Low)	CFM	588/471/394	824/647/559	971/764/647	1059/847/741	1177/1059/941	
	dB(A)	43/40/38	48/43/40	50/47/44	51/48/45	55/51/48	
Dimension (WxDxH)	Net(Body)	mm	835 × 835 × 250	835 × 835 × 250	835 × 835 × 290	835 × 835 × 290	835 × 835 × 290
	Packing(Body)	mm	910 × 910 × 310	910 × 910 × 310	910 × 910 × 350	910 × 910 × 350	910 × 910 × 350
	Net(Panel)	mm	950 × 950 × 55	950 × 950 × 55	950 × 950 × 55	950 × 950 × 55	950 × 950 × 55
Weight	Packing(Panel)	mm	1000 × 1000 × 100	1000 × 1000 × 100	1000 × 1000 × 100	1000 × 1000 × 100	1000 × 1000 × 100
	Net(Body)/Gross(Body)	kg	24/29	25/30	28/33	28/33	31/36
Piping Size	Net(Panel)/Gross(Panel)	kg	5/7	5/7	5/7	5/7	5/7
	Drainage	mm(inch)	DN20(R3/4)	DN20(R3/4)	DN20(R3/4)	DN20(R3/4)	DN20(R3/4)
Stuffing Quantity	20/40/40H	set	40/81/92	42/82/92	32/87/90	20/48/54	22/50/55

★ Remark:  
 1.The above designs and specifications are subject to change without prior notice. Final specifications please refer to technical specification provided by sales representative.  
 2.Cooling Capacity and Cooling Input Power (T1):Indoor Temperature 26.7°C DB/19.4°C WB; Ambient Temperature 35°C DB/24°C WB.  
 3.Cooling Capacity and Cooling Input Power (T3):Indoor Temperature 26.7°C DB/19.4°C WB; Ambient Temperature 46.1°C DB.  
 4.The Max.Ambient temperature for units running is 55°C.

# T1 R410a 50Hz





## Universal Outdoor Units

### Specification-R410a 50Hz DC Inverter



Model	Outdoor		KOU18H-4VR1	KOU24H-4VR1	KOU36H-4VR1	KOU48H-5VR1	KOU60H-5VR1
Electric Data	Power Supply	V~,Hz,Ph	220-240,50,1	220-240,50,1	220-240,50,1	380-415,50,3	380-415,50,3
	Air Flow Volume	m <sup>3</sup> /h	2600	2800	3900	6400	6400
Performance	Noise Level	dB(A)	55	60	60	56	56
	Net	mm	800 × 288 × 530	890 × 320 × 670	900 × 320 × 790	940 × 368 × 1366	940 × 368 × 1366
Dimension (WxDxH)	Packing	mm	920 × 400 × 620	1020 × 430 × 760	1030 × 430 × 850	1080 × 460 × 1500	1080 × 460 × 1500
	Net/Gross	kg	42/45	51/55	60/64	108/113	108/113
Piping size	Liquid Side	mm(inch)	6.35(1/4)	9.52(3/8)	9.52(3/8)	9.52(3/8)	9.52(3/8)
	Gas Side	mm(inch)	12.7(1/2)	15.88(5/8)	15.88(5/8)	19.05(3/4)	19.05(3/4)
	Max. Length	m	20	30	30	50	50
Stuffing Quantity	Max. Height	m	15	15	20	30	30
	20/40/40H	unit	102/210/280	102/210/210	58/122/183	27/55/55	27/55/55

### Specification-R410a 50Hz ON/OFF



Model	Outdoor		KOU12H-4R1D	KOU18H-4R1D	KOU24H-4R1D	KOU36H-4R1D	KOU36H-5R1D	KOU48H-5R1D	KOU60H-5R1D
Electric Data	Power Supply	V~,Hz,Ph	220-240,50,1	220-240,50,1	220-240,50,1	220-240,50,1	380-415,50,3	380-415,50,3	380-415,50,3
	Air Flow Volume	m <sup>3</sup> /h	2500	2500	3500	3190	3190	6400	6400
Performance	Noise Level	dB(A)	53	55	60	60	62	60	60
	Net	mm	800 × 286 × 530	800 × 286 × 530	822 × 302 × 655	903 × 354 × 857	903 × 354 × 857	940 × 368 × 1366	940 × 368 × 1366
Dimension (WxDxH)	Packing	mm	920 × 400 × 620	920 × 400 × 620	945 × 430 × 725	1030 × 410 × 980	1030 × 410 × 980	1080 × 460 × 1500	1080 × 460 × 1500
	Net/Gross	kg	34/37	38/41	50/54	72/83	71/81	101/112	102/113
Piping size	Liquid Side	mm(inch)	6.35(1/4)	6.35(1/4)	9.52(3/8)	9.52(3/8)	9.52(3/8)	9.52(3/8)	9.52(3/8)
	Gas Side	mm(inch)	12.7(1/2)	12.7(1/2)	15.88(5/8)	15.88(5/8)	15.88(5/8)	19.05(3/4)	19.05(3/4)
	Max. Length	m	15	20	30	50	50	50	50
Stuffing Quantity	Max. Height	m	10	15	15	30	30	30	30
	20/40/40H	unit	102/219/292	102/219/292	87/183/183	60/126/126	60/126/126	27/55/55	27/55/55

### Specification-R410a 50Hz ON/OFF



Model	Indoor		KOU12C-4R1D	KOU18C-4R1D	KOU24C-4R1D	KOU36C-5R1D	KOU48C-5R1D	KOU60C-5R1D
Electric Data	Power Supply	V~,Hz,Ph	220-240,50,1	220-240,50,1	220-240,50,1	380-415,50,3	380-415,50,3	380-415,50,3
	Air Flow Volume	m <sup>3</sup> /h	1980	2600	2790	3190	5200	5200
Performance	Noise Level	dB(A)	53	55	60	60	62	62
	Net	mm	760 × 260 × 540	800 × 300 × 590	800 × 300 × 690	903 × 354 × 857	945 × 340 × 1255	945 × 340 × 1255
Dimension (WxDxH)	Packing	mm	880 × 350 × 610	930 × 410 × 660	930 × 410 × 760	1030 × 410 × 980	1090 × 430 × 1370	1090 × 430 × 1370
	Liquid Side	mm(inch)	31/34	35/43	48/52	88/96	92/106	94/108
Piping size	Gas Side	mm(inch)	6.35(1/4)	6.35(1/4)	9.52(3/8)	9.52(3/8)	9.52(3/8)	9.52(3/8)
	Max. Length	m	12.7(1/2)	12.7(1/2)	15.88(5/8)	15.88(5/8)	19.05(3/4)	19.05(3/4)
	Max. Height	m	15	20	30	50	50	50
Stuffing Quantity	20/40/40H	unit	10	15	15	30	30	30
	20/40/40H	set	123/261/348	102/210/280	102/210/210	60/126/126	27/55/55	27/55/55

\* Remark: The above designs and specifications are subject to change without prior notice. Final specifications please refer to technical specification provided by sales representative.

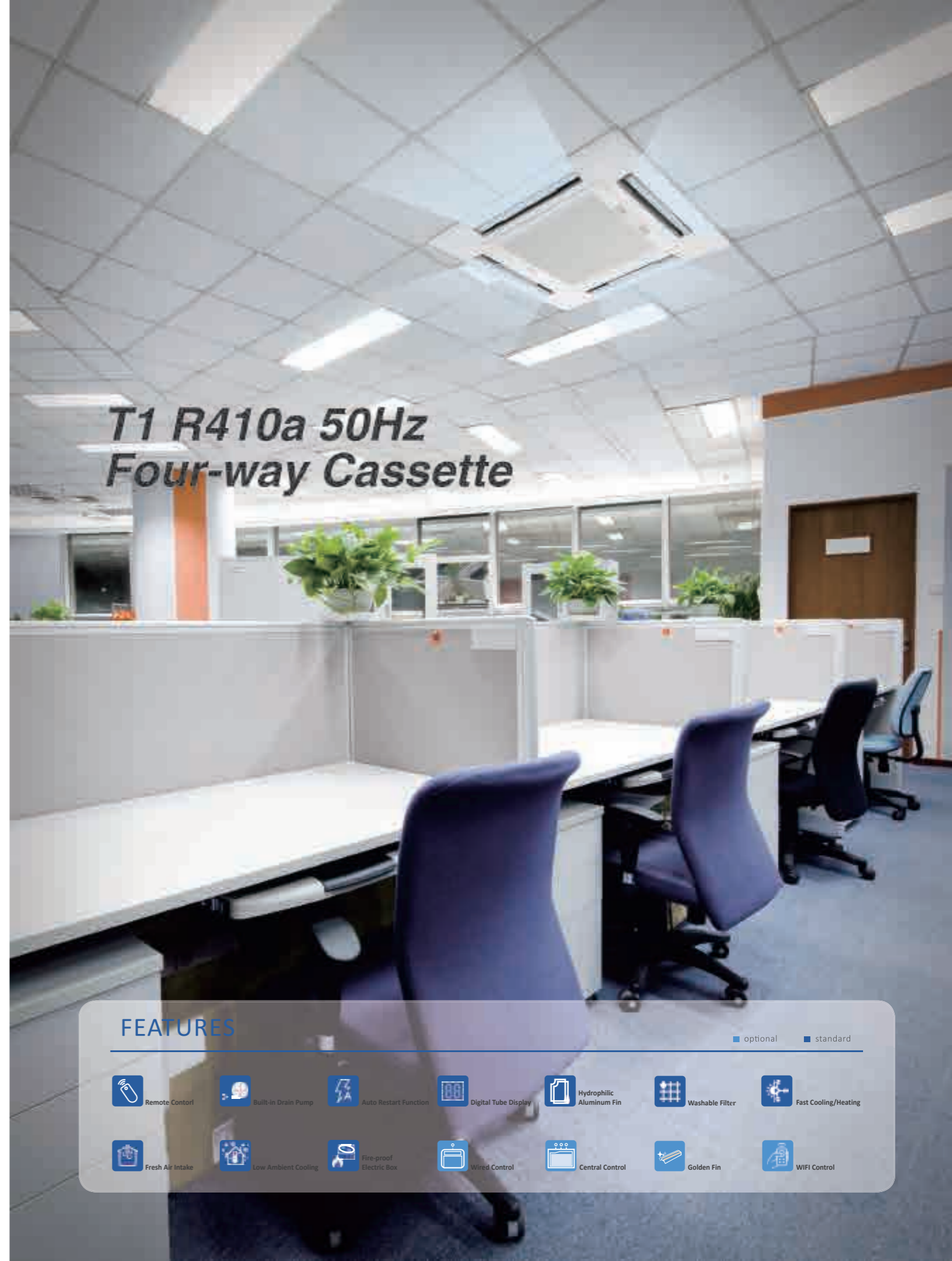

## T1 R410a 50Hz Four-way Cassette

### FEATURES

■ optional ■ standard

- Remote Control
- Built-in Drain Pump
- Auto Restart Function
- Digital Tube Display
- Hydrophilic Aluminum Fin
- Washable Filter
- Fast Cooling/Heating
- Fresh Air Intake
- Low Ambient Cooling
- Fire-proof Electric Box
- Wired Control
- Central Control
- Golden Fin
- WiFi Control

# T1 R410a 50Hz- Four-Way Cassette



## Built-in Water Drainage Pump

The built-in pump can lift condensing water up to 1200mm high from the drainage pan.

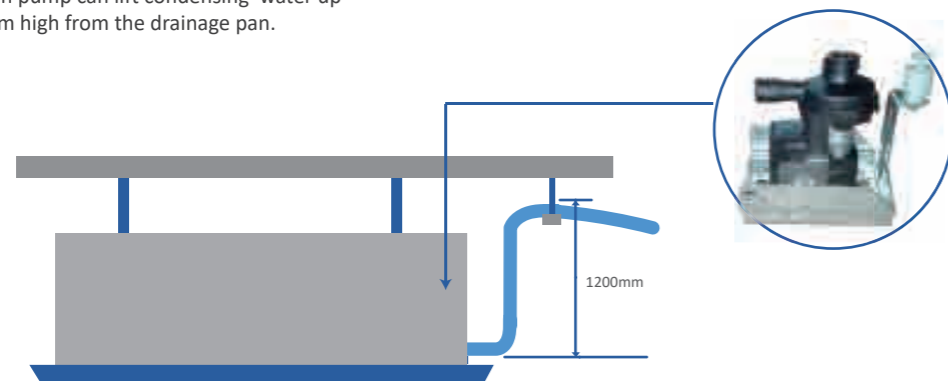

## Fresh Air Intake

Fresh air makes indoor air healthy and comfortable.



## Optimized Electric Box

Better fire-proof and easy to maintenance.

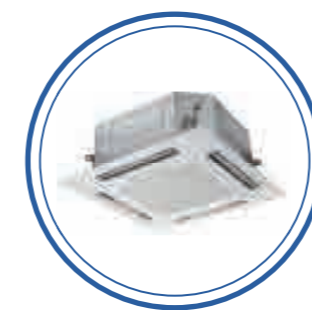
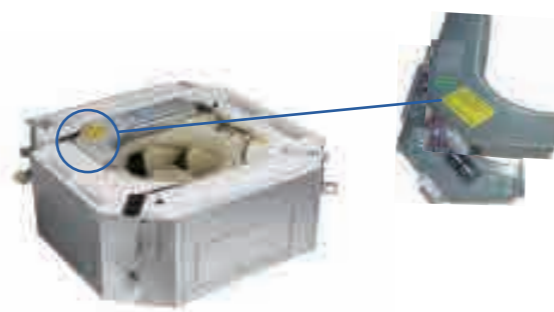

## Four-Way Cassette

### Specification-R410a 50Hz DC Inverter

Model	Indoor		KNC18H-4VR1	KNC24H-4VR1	KNC36H-4VR1
	Outdoor		KOU18H-4VR1	KOU24H-4VR1	KOU36H-4VR1
Capacity	Cooling/Heating	Btu/h	18000(5300-19200)/19000(4800-20300)	24000(7400-27100)/27000(6800-29700)	36000(10300-37600)/37500(11800-45200)
		kW	5.10(1.53-5.61)/5.60(1.40-5.94)	7.20(2.16-7.92)/7.90(1.98-8.69)	10.00(3.00-11.00)/11.50(3.45-13.23)
Electric Data	Power Supply	V-,Hz,Ph	220-240,50,1	220-240,50,1	220-240,50,1
		Cooling/Heating Power Input	kW	1.58(0.47-2.05)/1.55(0.46-2.01)	2.22(0.67-2.88)/2.16(0.65-2.81)
Performance	EER/COP	W/W	3.23/3.61	3.25/3.66	3.24/3.63
		Air Flow Volume	m <sup>3</sup> /h	850/680/595	1100/880/770
Dimension	Noise Level	dB(A)	41/38/32	45/42/36	48/45/39
		Net(Body)	mm	615 × 615 × 263	835 × 835 × 250
(WxDxH)	Packing(Body)	mm	700 × 690 × 330	910 × 910 × 310	910 × 910 × 310
	Net(Panel)	mm	650 × 650 × 55	950 × 950 × 55	950 × 950 × 55
	Packing(Panel)	mm	710 × 710 × 80	1000 × 1000 × 100	1000 × 1000 × 100
Weight	Net/Gross (Body)	kg	18/22	24/27.5	24/27.5
	Net/Gross (Panel)	kg	3/5	5/7	5/7
Piping size	Drainage	mm(Inch)	DN20(R3/4)	DN20(R3/4)	DN20(R3/4)
Stuffing Quantity	20/40/40H	set	44/135/156	39/93/103	34/68/85

### Specification-R410a 50Hz DC Inverter

Model	Indoor		KNC48H-5VR1	KNC60H-5VR1
	Outdoor		KOU48H-5VR1	KOU60H-5VR1
Capacity	Cooling/Heating	Btu/h	48000(14400-51600)/51000(18600-58200)	55000(16400-58400)/63000(21500-67600)
		kW	14.00(4.20-15.12)/15.50(5.43-17.05)	16.00(4.80-16.80)/18.00(6.30-19.80)
Electric Data	Power Supply	V-,Hz,Ph	380-415,50,3	380-415,50,3
		Cooling/Heating Power Input	kW	4.29(1.29-5.58)/4.20(1.26-5.46)
Performance	EER/COP	W/W	3.26/3.69	3.21/3.64
		Air Flow Volume	m <sup>3</sup> /h	1800/1440/1260
Dimension	Noise Level	dB(A)	50/47/41	50/47/41
		Net(Body)	mm	835 × 835 × 290
(WxDxH)	Packing(Body)	mm	910 × 910 × 350	910 × 910 × 350
	Net(Panel)	mm	950 × 950 × 55	950 × 950 × 55
	Packing(Panel)	mm	1000 × 1000 × 100	1000 × 1000 × 100
Weight	Net/Gross (Body)	kg	26.5/30.5	26.5/30.5
	Net/Gross (Panel)	kg	5/7	5/7
Piping size	Drainage	mm(Inch)	DN20(R3/4)	DN20(R3/4)
Stuffing Quantity	20/40/40H	set	22/50/55	22/50/55

\* Remark: The above designs and specifications are subject to change without prior notice. Final specifications please refer to technical specification provided by sales representative.





# T1 R410a 50Hz- Ceiling&Floor



## 4D Air Swing

Vertical and horizontal swing makes air below to every corner of the room.



## Ultra Slim Design

The thickness is only 205mm, save installation space.



## Innovative Centrifugal Fan

All units are equipped with 3-speed fan mode, adjusting the air flow rate in accordance with the ceiling height. Innovative centrifugal fan provides larger air volume but lower noise, making the air supply more quietly and smoothly.



## Flexible Installation

Can be vertically installed against the wall or horizontally installed under the ceiling.

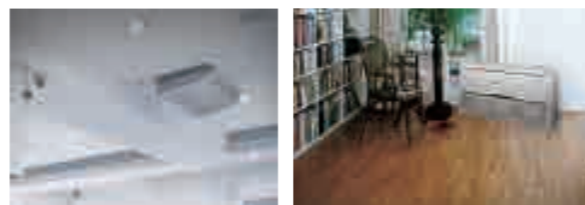

## Ceiling&Floor

### Specification-R410a 50Hz DC Inverter

Model	Indoor		KNE18H-4VR1	KNE24H-4VR1	KNE36H-4VR1
	Outdoor		KOU18H-4VR1	KOU24H-4VR1	KOU36H-4VR1
Capacity	Cooling/Heating	Btu/h	18000(19200-5300)/19000(20300-4800)	24000(27100-7400)/27000(29700-6800)	36000(37600-10300)/37500(45200-11800)
		kW	5.10(5.61-1.53)/5.60(5.94-1.40)	7.20(7.92-2.16)/7.90(8.69-1.98)	10.00(11.00-3.00)/11.50(13.23-3.45)
Electric Data	Power Supply	V~,Hz,Ph	220-240,50,1	220-240,50,1	220-240,50,1
		Cooling/Heating Power Input	KW	1.58(2.05-0.47)/1.55(2.01-0.46)	2.22(2.88-0.67)/2.16(2.81-0.65)
Performance	EER/COP	W/W	3.23/3.61	3.25/3.66	3.24/3.63
		Air Flow Volume	m <sup>3</sup> /h	850/680/595	1200/960/840
Dimension (WxDxH)	Noise Level	dB(A)	43/40/34	46/43/38	50/47/41
		Net	mm	930 × 660 × 205	1280 × 660 × 205
Weight	Packing	mm	1010 × 720 × 290	1360 × 720 × 290	1360 × 720 × 290
		kg	25/28	32/37	33/38
Piping size	Drainage	mm(Inch)	DN20(R3/4)	DN20(R3/4)	DN20(R3/4)
Stuffing Quantity	20/40/40H	set	54/120/144	48/104/105	40/84/92

### Specification-R410a 50Hz DC Inverter

Model	Indoor		KNE48H-5VR1	KNE60H-5VR1
	Outdoor		KOU48H-5VR1	KOU60H-5VR1
Capacity	Cooling/Heating	Btu/h	48000(51600-14400)/51000(58200-18600)	55000(58400-16400)/63000(67600-21500)
		kW	14.00(15.12-4.20)/15.50(17.05-5.43)	16.00(16.80-4.80)/18.00(19.80-6.30)
Electric Data	Power Supply	V~,Hz,Ph	380-415,50,3	380-415,50,3
		Cooling/Heating Power Input	KW	4.29(5.58-1.29)/4.20(5.46-1.26)
Performance	EER/COP	W/W	3.26/3.69	3.21/3.64
		Air Flow Volume	m <sup>3</sup> /h	1800/1440/1260
Dimension (WxDxH)	Noise Level	dB(A)	51/48/42	51/48/42
		Net	mm	1630 × 660 × 205
Weight	Packing	mm	1710 × 720 × 290	1710 × 720 × 290
		kg	44/50	44/50
Piping size	Drainage	mm(Inch)	DN20(R3/4)	DN20(R3/4)
Stuffing Quantity	20/40/40H	set	22/55/55	22/55/55

\* Remark: The above designs and specifications are subject to change without prior notice. Final specifications please refer to technical specification provided by sales representative.



## Ceiling&Floor

### Specification-R410a 50Hz ON/OFF



Model	Indoor		ANE18H-4R1C	ANE24H-4R1C	ANE36H-4R1C	ANE36H-5R1C	ANE48H-5R1C	ANE60H-5R1C
	Outdoor		KOU18H-4R1D	KOU24H-4R1D	KOU36H-4R1D	KOU36H-5R1D	KOU48H-5R1D	KOU60H-5R1D
Capacity	Cooling/Heating	Btu/h	18000/20000	24000/27500	36000/40000	36000/40000	48000/53000	60000/63500
		kW	5.30/5.80	7.2/8.08	10.60/11.70	10.60/11.70	14.00/15.50	17.60/18.50
Electric Data	Power Supply	V-,Hz,Ph	220-240,50,1	220-240,50,1	220-240,50,1	380-415,50,3	380-415,50,3	380-415,50,3
		Cooling/Heating Power Input	kW	1.72/1.77	2.35/2.40	3.77/3.50	3.77/3.50	4.87/5.13
Performance	Cooling/Heating Current	A	7.90/8.13	10.09/11.59	17.30/16.60	6.76/6.28	8.88/9.33	10.42/10.83
		EER/COP	WW	3.08/3.28	3.06/3.37	2.81/3.34	2.81/3.34	2.87/3.02
Dimension	Air Flow Volume	m <sup>3</sup> /h	850/680/595	1200/960/840	1500/1200/1050	1500/1200/1050	1800/1440/1260	1800/1440/1260
		Noise Level	dB(A)	43/40/34	46/43/38	50/47/41	50/47/41	51/48/42
Weight	Net	mm	929 × 660 × 205	1280 × 660 × 205	1280 × 660 × 205	1280 × 660 × 205	1631 × 660 × 205	1631 × 660 × 205
		Packing	mm	1010 × 720 × 290	1360 × 720 × 290	1360 × 720 × 290	1360 × 720 × 290	1710 × 720 × 290
Piping size	Drainage	mm(Inch)	DN20(R3/4)	DN20(R3/4)	DN20(R3/4)	DN20(R3/4)	DN20(R3/4)	DN20(R3/4)
		kg	25/28	32/37	33/40	33/40	44/52	44/52
Stuffing Quantity	20/40/40H	set	60/134/149	43/92/104	36/82/88	36/82/88	22/55/55	22/55/55

### Specification-R410a 50Hz ON/OFF



Model	Indoor		ANE18C-4R1	ANE24C-4R1	ANE36C-5R1	ANE48C-5R1	ANE60C-5R1
	Outdoor		KOU18C-4R1D	KOU24C-4R1D	KOU36C-5R1D	KOU48C-5R1D	KOU60C-5R1D
Capacity	Cooling/Heating	Btu/h	18000/-	24000/-	36000/-	48000/-	60000/-
		kW	5.30/-	7.20/-	10.60/-	14.00/-	17.60/-
Electric Data	Power Supply	V-,Hz,Ph	220-240,50,1	220-240,50,1	380-415,50,3	380-415,50,3	380-415,50,3
		Cooling/Heating Power Input	kW	1.72 /-	2.18 /-	3.77 /-	4.87 /-
Performance	Cooling/Heating Current	A	7.90 /-	10.09 /-	6.76 /-	8.88 /-	10.42 /-
		EER/COP	WW	3.08/-	3.30 /-	2.81 /-	2.87 /-
Dimension	Air Flow Volume	m <sup>3</sup> /h	850/680/595	1200/960/840	1500/1200/1050	1800/1440/1260	1800/1440/1260
		Noise Level	dB(A)	43/40/34	46/43/38	50/47/41	51/48/42
Weight	Net	mm	929 × 660 × 205	1280 × 660 × 205	1280 × 660 × 205	1631 × 660 × 205	1631 × 660 × 205
		Packing	mm	1010 × 720 × 290	1360 × 720 × 290	1360 × 720 × 290	1710 × 720 × 290
Piping size	Drainage	mm(Inch)	DN20(R3/4)	DN20(R3/4)	DN20(R3/4)	DN20(R3/4)	DN20(R3/4)
		kg	25/28	32/37	33/40	44/52	44/52
Stuffing Quantity	20/40/40H	set	54/120/144	48/104/105	36/82/88	24/54/55	24/54/55

\* Remark: The above designs and specifications are subject to change without prior notice. Final specifications please refer to technical specification provided by sales representative.



## T1 R410a 50Hz Mid ESP Duct

### FEATURES

■ optional ■ standard

- Wired Control
- 3D Air Flow
- Auto Restart Function
- Long-term Filter
- Hydrophilic Aluminum Fin
- Intelligent Defrosting
- Fast Cooling/Heating
- Low Ambient Cooling
- Remote control
- Central Control
- Golden Fin
- WiFi Control

# T1 R410a 50Hz- Mid ESP Duct



## Built-in With Water Pump (Optional)

The built-in pump can lift condensing water up to 1200mm high from the drainage pan.

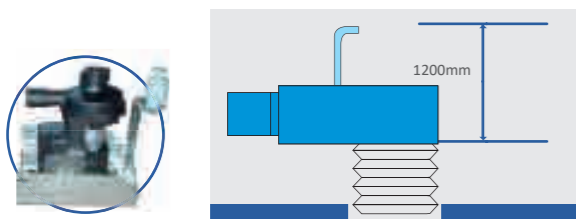

## Flexible Air Intake Options

Air intake from rear as standard, from bottom is optional. The size of the plate from bottom is the same as the flange from back, which makes it convenient to change installation style due to different decoration requirements.

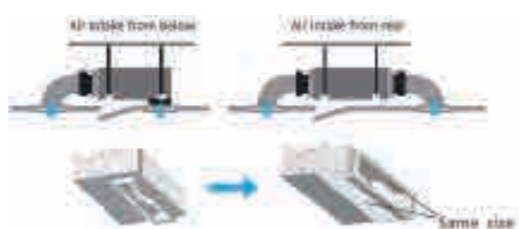

## Optional ESP (Mid ESP)

50Pa and 80Pa can be freely chosen.

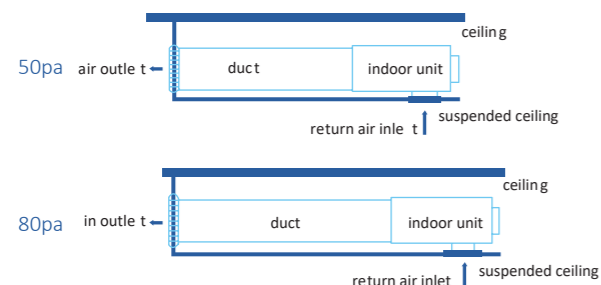

## Fresh Air Intake

Fresh air makes indoor air healthy and comfortable.

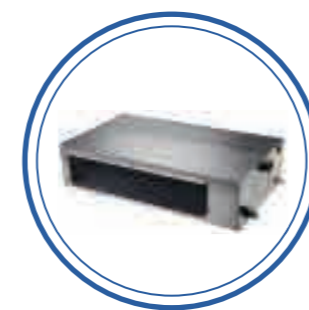
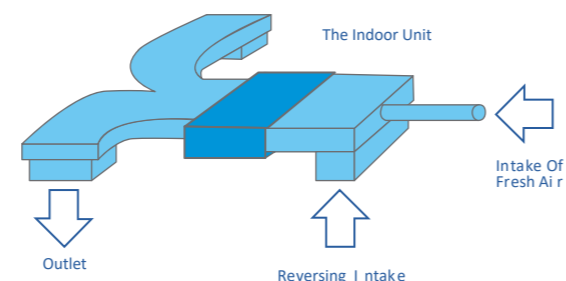

# Mid ESP Duct

## Specification-R410a 50Hz DC Inverter

Model	Indoor	KNM18H-4VR1		KNM24H-4VR1		KNM36H-4VR1	
	Outdoor	KOU18H-4VR1		KOU24H-4VR1		KOU36H-4VR1	
Capacity	Cooling/Heating	Btu/h	18000(19200-5300)/19000(20300-4800)	24000(27100-7400)/27000(29700-6800)	36000(37600-10300)/37500(45200-11800)		
		kW	5.10(5.61-1.53)/5.60(5.94-1.40)	7.20(7.92-2.16)/7.90(8.69-1.98)	10.00(11.00-3.00)/11.50(13.23-3.45)		
Electric Data	Power Supply	V-,Hz,Ph	220-240,50,1		220-240,50,1		
	Cooling/Heating Power Input	kW	1.58(2.05-0.47)/1.55(2.01-0.46)		2.22(2.88-0.67)/2.16(2.81-0.65)		3.09(4.01-0.93)/3.17(4.12-0.95)
Performance	EER/COP	W/W	3.23/3.62		3.25/3.65		3.24/3.63
	Air Flow Volume	m³/h	950/760/665		1200/960/840		1500/1200/1050
	Noise Level	dB(A)	44/41/35		47/44/38		50/47/41
	ESP	Pa	50/80		50/80		50/80
Dimension	Net	mm	890 × 785 × 290		890 × 785 × 290		890 × 785 × 290
	(WxDxH) Packing	mm	1100 × 870 × 360		1100 × 870 × 360		1100 × 870 × 360
Weight	Net/Gross	kg	34/40		36/42		36/42
Piping size	Drainage	mm(Inch)	DN20(R3/4)		DN20(R3/4)		DN20(R3/4)
Stuffing Quantity	20/40/40H	set	41/94/112		40/90/105		36/72/84

## Specification-R410a 50Hz DC Inverter

Model	Indoor	KNM48H-5VR1		KNM60H-5VR1		
	Outdoor	KOU48H-5VR1		KOU60H-5VR1		
Capacity	Cooling/Heating	Btu/h	48000(51600-14400)/51000(58200-18600)	55000(58400-16400)/63000(67600-21500)		
		kW	14.00(15.12-4.20)/15.50(17.05-5.43)	16.00(16.80-4.80)/18.00(19.80-6.30)		
Electric Data	Power Supply	V-,Hz,Ph	380-415,50,3		380-415,50,3	
	Cooling/Heating Power Input	kW	4.29(5.58-1.29)/4.20(5.46-1.26)		4.98(6.48-1.49)/4.95(6.43-1.49)	
Performance	EER/COP	W/W	3.26/3.69		3.21/3.64	
	Air Flow Volume	m³/h	2000/1600/1400		2000/1600/1400	
	Noise Level	dB(A)	53/50/44		53/50/44	
	ESP	Pa	50/80		50/80	
Dimension	Net	mm	1250 × 785 × 290		1250 × 785 × 290	
	(WxDxH) Packing	mm	1460 × 870 × 360		1460 × 870 × 360	
Weight	Net/Gross	kg	52/59		52/59	
Piping size	Drainage	mm(Inch)	DN20(R3/4)		DN20(R3/4)	
Stuffing Quantity	20/40/40H	set	21/44/47		21/44/47	

\* Remark:The above designs and specifications are subject to change without prior notice. Final specifications please refer to technical specification provided by sales representative.



# Commercial-High ESP Duct



## Three Speed Fan Motor

Outdoor unit 3 fan speeds with better low temp. cooling.

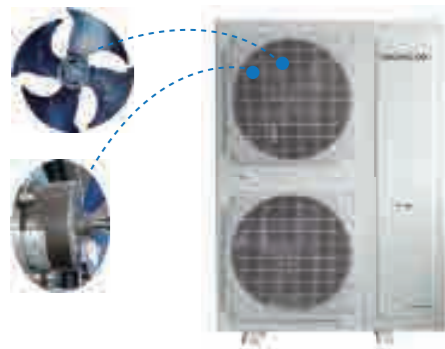

## Long Distance Air Supply

High ESP design makes the air supply longest distance 50m, and the air supplied is distributed well.

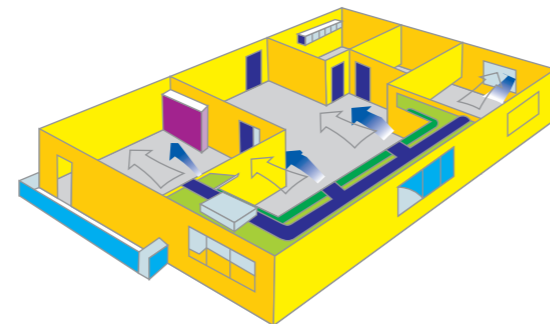

## Wide Operation Range

The unit could operate perfectly between 52°C in hot summer and -15°C in cold winter making you feel like spring all year around, advanced system design and strict system matching and test.



# Commercial High ESP Duct

## Specification-R410a

Model	Indoor		KNH80H-5R1S	KNH100H-5R1S	
	Outdoor		KHD80H-5R1S	KHD100H-5R1S	
<b>Indoor</b>					
Capacity	Cooling/Heating	Btu/h	76000/83600	96000/105600	
		kW	22.00/24.50	28.00/31.00	
Electric Data	Power Supply	V-,Hz,Ph	380-415,50,3	380-415,50,3	
	Cooling/Heating Power Input	kW	8.30/7.50	10.60/9.48	
	Cooling/Heating Current	A	13.41/12.10	17.07/15.35	
Performance	EER/COP	W/W	2.65/3.27	2.64/3.27	
	Net Dimension	mm	1350 × 700 × 460	1350 × 700 × 460	
Indoor	Packing Dimension	mm	1540 × 810 × 610	1540 × 810 × 610	
	Net/Gross Weight	kg	90/110	91/111	
	Air Flow Volume	m³/h	5000/4000/3600	5000/4000/3600	
	Noise Leve	dB(A)	55	55	
	ESP	Pa	150	150	
	<b>Outdoor</b>				
	Outdoor	Net Dimension	mm	1120 × 400 × 1510	1120 × 400 × 1510
Packing Dimension		mm	1270 × 545 × 1710	1270 × 545 × 1710	
Net/Gross Weight		kg	175/190	176/191	
Air Flow Volume		m³/h	6000 × 2	6000 × 2	
Noise Level		dB(A)	58	58	
Piping size	Liquid Side	mm(inch)	9.52(3/8) × 2	9.52(3/8) × 2	
	Gas Side	mm(inch)	19.05(3/4) × 2	19.05(3/4) × 2	
	Max. Length	m	50	50	
	Max. Height	m	20	20	
Stuffing Quantity	20/40/40H	set	12/25/28	12/25/28	

\* Remark:The above designs and specifications are subject to change without prior notice. Final specifications please refer to technical specification provided by sales representative.

# Commerical Floor&Standing



## Commerical-Floor Standing



Standard



### Touch Screen Design

Elegant touch screen design, longer lifetime than traditional button design.



### Innovative Diversion Design

The special design at air inlet side makes strong air flow more even and more efficient.

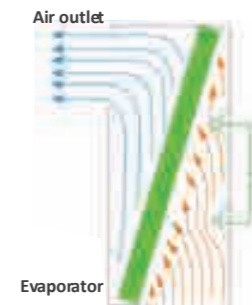

Innovation diversion desi heat exchange of evapora is more evenly more fully and increase heat transfe efficiency.

Double volute supply air inlet

### Ultra-Slim Design

The indoor unit is only 36cm in width, save installation space.



## FEATURES

■ optional ■ standard

-  Remote Control
-  Auto Restart Function
-  Fast Cooling/Heating
-  Compressor Heating belt
-  Hydrophilic Aluminum Fin
-  Auto swing
-  Long-term Filter
-  Anti-Cold-Air
-  Self-diagnosis Function
-  Intelligent Defrosting
-  Central Control
-  WIFI Control



## Commerical Floor Standing

### Specification-R410a

Model	Indoor		KNF80H-5R1S	KNF100H-5R1S
	Outdoor		KFS80H-5R1S	KFS100H-5R1S
<b>Indoor</b>				
Capacity	Cooling / Heating	Btu/h	76000/83600	96000/105600
		kW	22.00/24.5	28.00/31.00
Electric Data	Power Supply	V~,Hz,Ph	380-415V,50Hz,3N	380-415V,50Hz,3N
	Cooling / Heating Power Input	kW	7.86/8.01	10.07/11.70
	Cooling / Heating Current	A	13.27 / 15.50	17.00/19.75
Performance	EER / COP	W/W	2.80/3.05	2.78/2.65
Indoor	Net Dimension	mm	1200 × 360 × 1850	1200 × 360 × 1850
	Packing Dimension	mm	1270 × 430 × 2000	1270 × 430 × 2000
	Net / Gross Weight	kg	110/130	111/131
	Air Flow Volume	m <sup>3</sup> /h	4000/3800/3600	4000/3800/3600
	Noise Level	dB(A)	56	56
	ESP	Pa	150	150
<b>Outdoor</b>				
Outdoor	Net Dimension	mm	1120 × 400 × 1510	1120 × 400 × 1510
	Packing Dimension	mm	1270 × 545 × 1710	1270 × 545 × 1710
	Net Weight	kg	175/190	176/191
	Air Flow Volume	m <sup>3</sup> /h	6000 × 2	6000 × 2
Piping size	Noise Level	dB(A)	58	58
	Liquid Side	mm(inch)	9.52(3/8) × 2	9.52(3/8) × 2
	Gas Side	mm(inch)	19.05(3/4) × 2	19.05(3/4) × 2
	Max. Length	m	50	50
	Max. Height	m	20	20
Stuffing Quantity	20/40/40H	set	9/20/20	9/20/20

\* Remark:The above designs and specifications are subject to change without prior notice. Final specifications please refer to technical specification provided by sales representative.

## T1 R410a 50Hz&60Hz





# T1 R410a 50Hz&60Hz- Outdoor Unit



## 180° Sine Wave Control

DC inverter compressor uses 180° sine wave vector control technique, make motor operate smoothly and efficiency increases significantly.

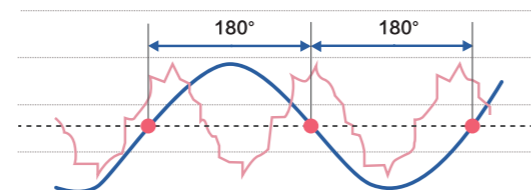

## Fast Cooling/Heating Technology

Calculate capacity after starting, then compressor run with frequency rising quickly, so that get cool/warm fast.

## Reliability

Stable cooling under -5°C and heating under -15°C outdoor environment temperature.

## Optimized Pipeline Design

The design ensures the sub-cooling and enhances the cooling capacity by separating the refrigerant inlet and outlet.

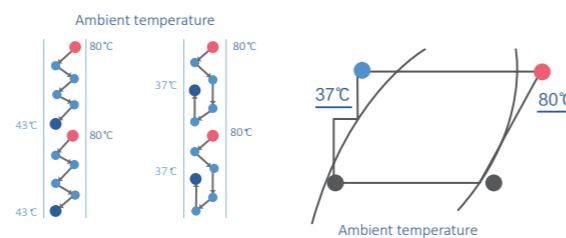

## Simulation Technology

Via analysing piping stress distribution, piping amplitude and displacement in transportation and operation, the reliability has been improved greatly.

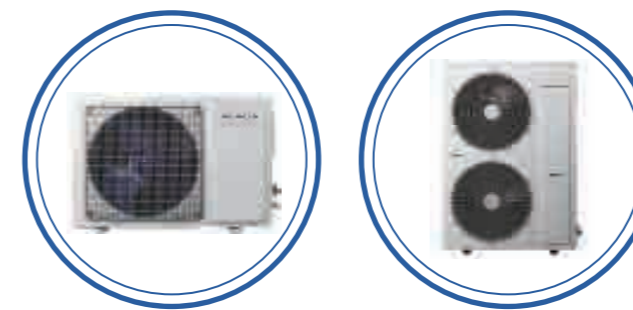
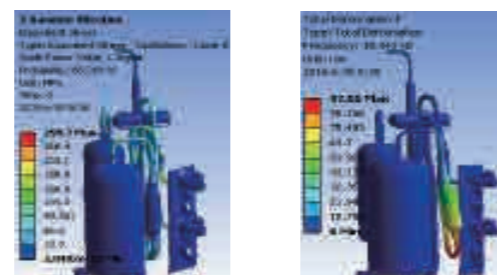

## Outdoor Units

### Specification-T1 R410a 50Hz&60Hz DC Inverter

Model	Outdoor	50Hz	KOU18H-4VR1E	KOU24H-4VR1E	KOU30H-4VR1E	KOU36H-4VR1E
		60Hz	KOU18H-2VR1E	KOU24H-2VR1E	KOU30H-2VR1E	KOU36H-2VR1E
Electric Data	Power Supply	V~, Hz, Ph	220-240/50/1&208-230/60/1	220-240/50/1&208-230/60/1	220-240/50/1&208-230/60/1	220-240/50/1&208-230/60/1
	Air Flow Volume	m³/h	2600	3750	3750	6400
Performance	Sound Pressure Noise Level	dB(A)	55	58	59	58
	Net	mm	800 × 286 × 530	890 × 320 × 670	890 × 320 × 670	940 × 368 × 1366
Dimension (WxDxH)	Packing	mm	920x400x620	1020x430x760	1020x430x760	1080 × 460 × 1500
	Net/Gross	kg	40/44	53/58	54/59	93/103
Weight	Liquid Side	mm(inch)	6.35(1/4)	9.52(3/8)	9.52(3/8)	9.52(3/8)
	Gas Side	mm(inch)	12.7(1/2)	15.88(5/8)	15.88(5/8)	15.88(5/8)
Piping size	Max. Length	m	20	30	30	30
	Max. Height	m	15	15	15	15
Stuffing Quantity	20/40/40H	unit	102/219/292	87/183/183	87/183/183	27/55/55

### Specification-T1 R410a 50Hz&60Hz DC Inverter

Model	Outdoor	50Hz	KOU42H-4VR1E	KOU48H-4VR1E	KOU60H-4VR1E
		60Hz	KOU42H-2VR1E	KOU48H-2VR1E	KOU60H-2VR1E
Electric Data	Power Supply	V~, Hz, Ph	220-240/50/1&208-230/60/1	220-240/50/1&208-230/60/1	220-240/50/1&208-230/60/1
	Air Flow Volume	m³/h	6400	6400	6400
Performance	Sound Pressure Noise Level	dB(A)	58	59	59
	Net	mm	940 × 368 × 1366	940 × 368 × 1366	940 × 368 × 1366
Dimension (WxDxH)	Packing	mm	1080 × 460 × 1500	1080 × 460 × 1500	1080 × 460 × 1500
	Net/Gross	kg	93/103	108/116	108/116
Weight	Liquid Side	mm(inch)	9.52(3/8)	9.52(3/8)	9.52(3/8)
	Gas Side	mm(inch)	15.88(5/8)	19.05(3/4)	19.05(3/4)
Piping size	Max. Length	m	30	50	50
	Max. Height	m	15	30	30
Stuffing Quantity	20/40/40H	unit	27/55/55	27/55/55	27/55/55

\* Remark: The above designs and specifications are subject to change without prior notice. Final specifications please refer to technical specification provided by sales representative.

# T1 R410a 50Hz&60Hz- Four-Way Cassette

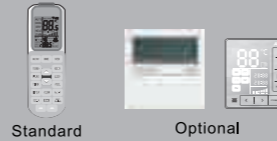

Standard

Optional

## T1 R410a 50Hz&60Hz Four-way Cassette

### Built-In Water Drainage Pump

The built-in pump can lift condensing water up to 1200mm high from the drainage pan.



### Fresh Air Intake

Fresh air makes indoor air healthy and comfortable.



### Optimized Electric Box

Better fire-proof and easy to maintenance.

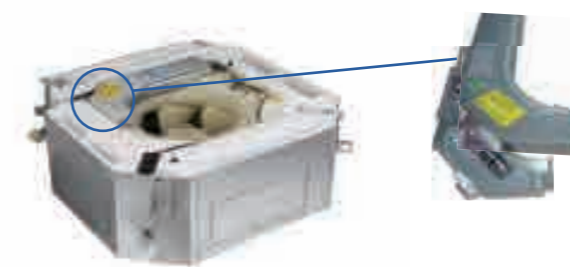

### Digital Tube Display

Digital tube displays all contents: indoor temperature, setting temperature, operation mode, etc. Clearly to check the running status, more convenient for trouble shooting .



## FEATURES

■ optional ■ standard

- Remote Control
- Built-in Drain Pump
- Auto Restart Function
- Digital Tube Display
- Hydrophilic Aluminum Fin
- Washable Filter
- Fast Cooling/Heating
- Fresh Air Intake
- Low Ambient Cooling
- Fire-proof Electric Box
- Wired Control
- Central Control
- Golden Fin
- WIFI Control

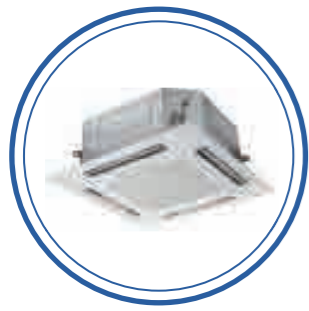

## Four-Way Cassette

### Specification-T1 R410a 50Hz&60Hz DC Inverter



Model		50Hz	ANC18H-4VR1E	ANC24H-4VR1E	ANC30H-4VR1E	ANC36H-4VR1E
			KOU18H-4VR1E	KOU24H-4VR1E	KOU30H-4VR1E	KOU36H-4VR1E
Model		60Hz	ANC18H-2VR1E	ANC24H-2VR1E	ANC30H-2VR1E	ANC36H-2VR1E
			KOU18H-2VR1E	KOU24H-2VR1E	KOU30H-2VR1E	KOU36H-2VR1E
Capacity	Cooling/Heating	Btu/h	18000(5220-19100)/19100(4800-21200)	24000(7400-28000)/27300(6800-31800)	30000(8500-31400)/30800(9800-32800)	36000(9900-41000)/42650(8900-41000)
		kW	5.00(1.53-5.60)/5.60(1.40-6.20)	7.00(2.16-8.20)/8.00(1.98-9.30)	8.30(2.49-9.20)/9.00(2.86-9.60)	10.5(2.9-12.0)/12.5(2.6-13.2)
Electric Data	Power Supply	V~,Hz,Ph	220-240/50/1&208-230/60/1	220-240/50/1&208-230/60/1	220-240/50/1&208-230/60/1	220-240/50/1&208-230/60/1
	Cooling /HeatingPower Input	kW	1.54(0.47-2.30)/1.55(0.46-2.25)	2.05(0.67-3.56)/2.20(0.65-3.62)	2.68(0.77-3.70)/2.62(0.78-3.70)	3.28(0.71-4.71)/3.64(0.47-4.13)
Performance	SEER/HSPF4		20.0/10.5	20.1/10.5	20.0/10.5	20.0/10.5
	Air Flow Volume	m <sup>3</sup> /h	800/670/550	1300/1050/950	1400/1150/1000	1800/1550/1350
	Sound Pressure Noise Level	dB(A)	46/44/36	47/43/38	48/44/39	51/48/45
Dimension (WxDxH)	Net(Body)	mm	615 × 615 × 263	835 × 835 × 250	835 × 835 × 250	835 × 835 × 290
	Packing(Body)	mm	700 × 690 × 330	910 × 910 × 310	910 × 910 × 310	910 × 910 × 350
	Net(Panel)	mm	650 × 650 × 55	950 × 950 × 55	950 × 950 × 55	950 × 950 × 55
	Packing(Panel)	mm	710 × 710 × 80	1000 × 1000 × 100	1000 × 1000 × 100	1000 × 1000 × 100
Weight	Net/Gross(Body)	kg	19/23	24/27.5	24/27.5	26.5/30.5
	Net/Gross(Panel)	kg	3/5	5/7	5/7	5/7
Piping size	Drainage	mm(inch)	20(R3/4)	20(R3/4)	20(R3/4)	20(R3/4)
Stuffing Quantity		set	66/137/161	42/82/92	42/82/92	22/50/55

### Specification-T1 R410a 50Hz&60Hz DC Inverter



Model		50Hz	ANC42H-4VR1E	ANC48H-4VR1E	ANC60H-4VR1E
			KOU42H-4VR1E	KOU48H-4VR1E	KOU60H-4VR1E
Model		60Hz	ANC42H-2VR1E	ANC48H-2VR1E	ANC60H-2VR1E
			KOU42H-2VR1E	KOU48H-2VR1E	KOU60H-2VR1E
Capacity	Cooling/Heating	Btu/h	42000(10900-45000)/46000(10200-50150)	48000(14000-54600)/55000(15700-59700)	55000(16400-59000)/60000(16700-63100)
		kW	12.1(3.2-13.2)/13.5(3.0-14.7)	14.00(4.10-16.00)/16.00(4.60-17.50)	16.00(4.80-17.30)/17.00(4.90-18.50)
Electric Data	Power Supply	V~,Hz,Ph	220-240/50/1&208-230/60/1	220-240/50/1&208-230/60/1	220-240/50/1&208-230/60/1
	Cooling /HeatingPower Input	kW	4.28(0.8-5.39)/4.10(0.58-4.90)	4.95(1.21-6.48)/4.57(0.92-5.66)	5.71(1.38-6.85)/4.96(0.98-6.00)
Performance	SEER/HSPF4		17.5/10.5	17.0/10.1	17.0/10.1
	Air Flow Volume	m <sup>3</sup> /h	1800/1550/1350	2050/1750/1500	2050/1750/1500
	Sound Pressure Noise Level	dB(A)	51/48/45	53/48/42	53/48/42
Dimension (WxDxH)	Net(Body)	mm	835 × 835 × 290	835 × 835 × 290	835 × 835 × 290
	Packing(Body)	mm	910 × 910 × 350	910 × 910 × 350	910 × 910 × 350
	Net(Panel)	mm	950 × 950 × 55	950 × 950 × 55	950 × 950 × 55
	Packing(Panel)	mm	1000 × 1000 × 100	1000 × 1000 × 100	1000 × 1000 × 100
Weight	Net/Gross(Body)	kg	26.5/30.5	26.5/30.5	26.5/30.5
	Net/Gross(Panel)	kg	5/7	5/7	5/7
Piping size	Drainage	mm(inch)	20(R3/4)	20(R3/4)	20(R3/4)
Stuffing Quantity		set	22/50/55	22/50/55	22/50/55

\* Remark: The above designs and specifications are subject to change without prior notice. Final specifications please refer to technical specification provided by sales representative.

## T1 R410a 50Hz&60Hz Ceiling&Floor



### FEATURES

■ optional ■ standard

- Remote Control
- 3D Air Flow
- Auto Restart Function
- Long-term Filter
- Hydrophilic Aluminum Fin
- Intelligent Defrosting
- Fast Cooling/Heating
- Low Ambient Cooling
- Wired Control
- Central Control
- Golden Fin
- WIFI Control

# T1 R410a 50Hz&60Hz- Ceiling&Floor

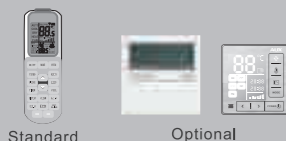

## 4D Air Swing

Vertical and horizontal swing makes air below to every corner of the room.



## Ultra Slim Design

The thickness is only 205mm, save installation space.



## Innovative Centrifugal Fan

All units are equipped with 3-speed fan mode, adjusting the air flow rate in accordance with the ceiling height. Innovative centrifugal fan provides larger air volume but lower noise, making the air supply more quietly and smoothly.



## Flexible Installation

Can be vertically installed against the wall or horizontally installed under the ceiling.

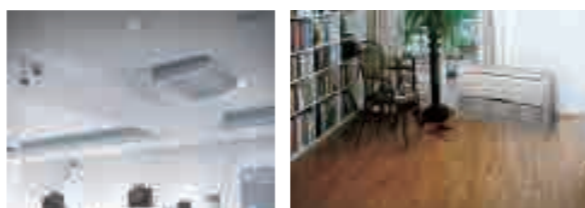

## Ceiling&Floor

### Specification-T1 R410a 50Hz&60Hz DC Inverter

Model		50Hz	ANE18H-4VR1E	ANE24H-4VR1E	ANE30H-4VR1E
			KOU18H-4VR1E	KOU24H-4VR1E	KOU30H-4VR1E
Model		60Hz	ANE18H-2VR1E	ANE24H-2VR1E	ANE30H-2VR1E
			KOU18H-2VR1E	KOU24H-2VR1E	KOU30H-2VR1E
Capacity	Cooling/Heating	Btu/h	18000(5220-19100)/19100(4800-21200)	24000(7400-28000)/27300(6800-31800)	30000(8500-31400)/30800(9800-32800)
		kW	5.00(1.53-5.60)/5.60(1.40-6.20)	7.00(2.16-8.20)/8.00(1.98-9.30)	8.30(2.49-9.20)/9.00(2.86-9.60)
Electric Data	Power Supply	V-,Hz,Ph	220-240/50/1&208-230/60/1	220-240/50/1&208-230/60/1	220-240/50/1&208-230/60/1
	Cooling/Heating Power Input	W	1.54(0.47-2.30)/1.55(0.46-2.25)	2.05(0.67-3.56)/2.20(0.65-3.62)	2.68(0.77-3.70)/2.62(0.78-3.70)
Performance	SEER/HSPF4	W/W	20.0/10.5	20.1/10.5	20.0/10.5
	Air Flow Volume	m³/h	900/730/650	1300/1052/920	1400/1200/1000
	Sound Pressure Noise Level	dB(A)	45/42/37	47/45/43	48/46/43
Dimension (WxDxH)	Net	mm	930 × 660 × 205	1280 × 660 × 205	1280 × 660 × 205
	Packing	mm	1010 × 720 × 290	1360 × 720 × 290	1360 × 720 × 290
Weight	Net/Gross	kg	25/28	32/38	32/38
Piping size	Drainage	mm(inch)	20(R3/4)	20(R3/4)	20(R3/4)
Stuffing Quantity	20/40/40H	set	60/134/149	43/92/104	43/92/104

### Specification-T1 R410a 50Hz&60Hz DC Inverter

Model		50Hz	ANE36H-4VR1E	ANE42H-4VR1E	ANE48H-4VR1E	ANE60H-4VR1E
			KOU36H-4VR1E	KOU42H-4VR1E	KOU48H-4VR1E	KOU60H-4VR1E
Model		60Hz	ANE36H-2VR1E	ANE42H-2VR1E	ANE48H-2VR1E	ANE60H-2VR1E
			KOU36H-2VR1E	KOU42H-2VR1E	KOU48H-2VR1E	KOU60H-2VR1E
Capacity	Cooling/Heating	Btu/h	36000(9900-41000)/42650(8900-41000)	41285(10900-45000)/46062(10200-50150)	48000(14000-54600)/55000(15700-59700)	55000(16400-59000)/60000(16700-63100)
		kW	10.5(2.9-12.0)/12.5(2.6-13.2)	12.1(3.2-13.2)/13.5(3.0-14.7)	14.00(4.10-16.00)/16.00(4.60-17.50)	16.00(4.80-17.30)/17.00(4.90-18.50)
Electric Data	Power Supply	V-,Hz,Ph	220-240/50/1&208-230/60/1	220-240/50/1&208-230/60/1	220-240/50/1&208-230/60/1	220-240/50/1&208-230/60/1
	Cooling/Heating Power Input	W	3.28(0.71-4.71)/3.64(0.47-4.13)	4.28(0.8-5.39)/4.10(0.58-4.90)	4.95(1.21-6.48)/4.57(0.92-5.66)	5.80(1.38-6.85)/4.96(0.98-6.00)
Performance	SEER/HSPF4	W/W	20.0/10.5	17.5/10.5	17.0/10.1	17.0/10.1
	Air Flow Volume	m³/h	1800/1550/1350	1800/1550/1350	2000/1600/1400	2000/1600/1400
	Sound Pressure Noise Level	dB(A)	53/50/47	53/50/47	54/50/46	54/50/46
Dimension (WxDxH)	Net	mm	1630 × 660 × 205	1630 × 660 × 205	1630 × 660 × 205	1630 × 660 × 205
	Packing	mm	1710 × 720 × 290	1710 × 720 × 290	1710 × 720 × 290	1710 × 720 × 290
Weight	Net/Gross	kg	44/50	44/50	44/50	44/50
Piping size	Drainage	mm(inch)	20(R3/4)	20(R3/4)	20(R3/4)	20(R3/4)
Stuffing Quantity	20/40/40H	set	22/55/55	22/55/55	22/55/55	22/55/55

\* Remark: The above designs and specifications are subject to change without prior notice. Final specifications please refer to technical specification provided by sales representative.

# T1 R410a 50Hz&60Hz Mid ESP Duct

# T1 R410a 50Hz&60Hz- Mid ESP Duct

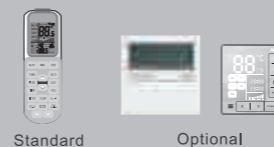

Standard      Optional



## Built In With Water Pump (Optional)

The built-in pump can lift condensing water up to 1200mm high from the drainage pan.

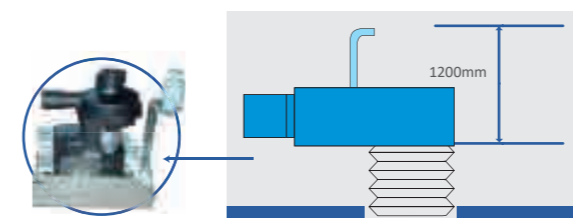

## Flexible Air Intake Options

Air intake from rear as standard, from bottom is optional. The size of the plate from bottom is the same as the flange from back, which makes it convenient to change installation style due to different decoration requirements.

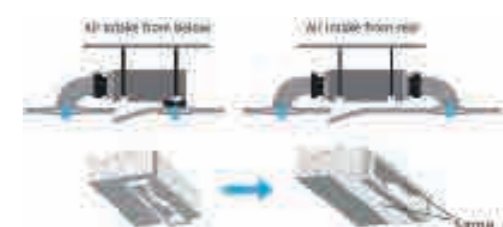

## Optional Esp (Mid ESP)

50Pa and 80Pa can be freely chosen.

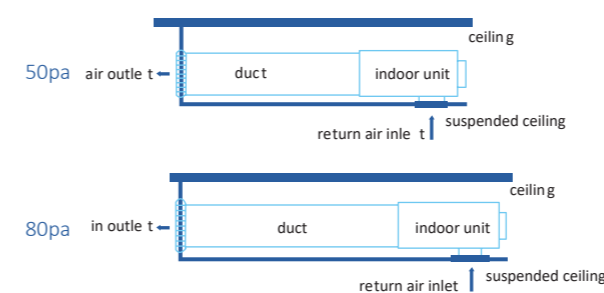

## Fresh Air Intake

Fresh air makes indoor air healthy and comfortable.

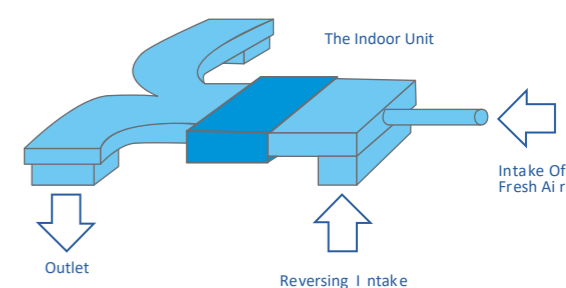

## FEATURES

- Wired Control
- 3D Air Flow
- Auto Restart Function
- Long-term Filter
- Hydrophilic Aluminum Fin
- Intelligent Defrosting
- Fast Cooling/Heating
- Low Ambient Cooling
- Remote control
- Central Control
- Golden Fin
- WiFi Control

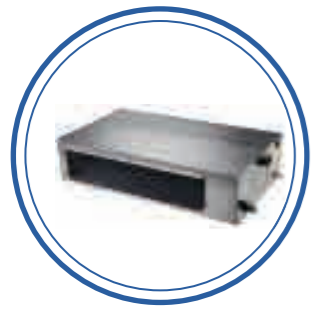

## Mid ESP Duct

### Specification-T1 R410a 50Hz&60Hz DC Inverter



Model	Indoor		Outdoor	
	50Hz	60Hz	ANM18H-4VR1E KOU18H-4VR1E	ANM24H-4VR1E KOU24H-4VR1E
Capacity	Cooling/Heating	Btu/h	18000(5220-19100)/19100(4800-21200)	24000(7400-28000)/27300(6800-31800)
		kW	5.00(1.53-5.60)/5.60(1.40-6.20)	7.00(2.16-8.20)/8.00(1.98-9.30)
Electric Data	Power Supply	V~,Hz,Ph	220-240/50/1&208-230/60/1	220-240/50/1&208-230/60/1
	Cooling/Heating Power Input	kW	1.54(0.47-2.30)/1.55(0.46-2.25)	2.05(0.67-3.56)/2.20(0.65-3.62)
Performance	SEER/HSPF4	W/W	20.0/10.5	20.1/10.5
	Air Flow Volume	m <sup>3</sup> /h	1150/960/840	1400/1190/980
	Sound Pressure Noise Level	dB(A)	42/40/37	46/42/38
	ESP	Pa	0-50	0-80
Dimension (WxDxH)	Net	mm	890 × 785 × 290	890 × 785 × 290
	Packing	mm	1100 × 870 × 360	1100 × 870 × 360
Weight	Net/Gross	kg	34/40	36/42
Piping size	Drainage	inch/mm	R3/4in(DN20)	R3/4in(DN20)
Stuffing Quantity	20/40/40H	set	43/95/110	36/78/94

### Specification-T1 R410a 50Hz&60Hz DC Inverter



Model	Indoor		Outdoor	
	50Hz	60Hz	ANM36H-4VR1E KOU36H-4VR1E	ANM42H-4VR1E KOU42H-4VR1E
Capacity	Cooling/Heating	Btu/h	36000(9900-40900)/42650(8900-45000)	48000(14000-54600)/55000(15700-59700)
		kW	10.5(2.9-12.0)/12.5(2.6-13.2)	14.0(4.10-16.00)/16.00(4.60-17.50)
Electric Data	Power Supply	V~,Hz,Ph	220-240/50/1&208-230/60/1	220-240/50/1&208-230/60/1
	Cooling/Heating Power Input	kW	3.28(0.71-4.71)/3.64(0.47-4.13)	4.67(1.21-6.48)/4.57(0.92-5.66)
Performance	SEER/HSPF4	W/W	20.0/10.5	17.0/10.1
	Air Flow Volume	m <sup>3</sup> /h	2000/1700/1450	2600/2000/1650
	Sound Pressure Noise Level	dB(A)	51/48/45	52/49/46
	ESP	Pa	0-80	0-80
Dimension (WxDxH)	Net	mm	1250 × 785 × 290	1250 × 785 × 290
	Packing	mm	1460 × 870 × 360	1460 × 870 × 360
Weight	Net/Gross	kg	53/60	52/59
Piping size	Drainage	inch/mm	R3/4in(DN20)	R3/4in(DN20)
Stuffing Quantity	20/40/40H	set	21/44/47	21/44/47

\* Remark: The above designs and specifications are subject to change without prior notice. Final specifications please refer to technical specification provided by sales representative.



**T1 R410a 50Hz&60Hz  
Free Match**

# T1 R410a 50Hz&60Hz-Free Match



## Space-Saving Installation

Up to 5 indoor units can be connected to a single outdoor unit, which reduces the number of outdoor units required so as to save installation space. Besides, each indoor unit can be controlled individually and they even needn't to be installed at the same time.

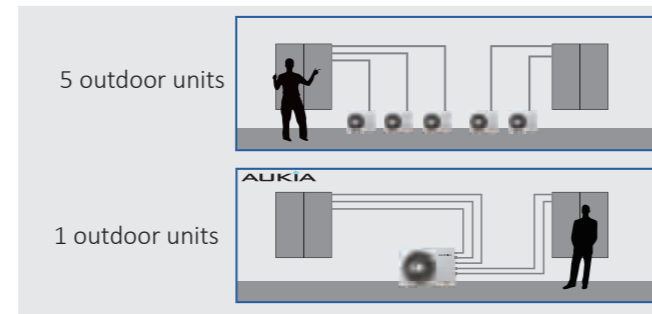

## Flexible Installation

Up to 60m of total piping length and 10m of the maximum height difference, it's more convenient for the location of indoor and outdoor units, also making the installation more simple, flexible and economical.

## Energy Saving

Cutting-edge DC inverter of sine wave control and active PFC technology realize low noise and economical operation.

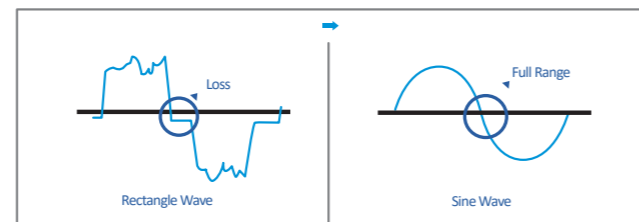

## Low Ambient Cooling

The unit has the feature that keeping running under low ambient temperature, even in -5°C.



# Free Match Combination

## Combination Table

Multi DC Outdoor Unit	Available Indoor Unit	Suggested Combination																											
<b>1 drive 2</b> KMD18H-4VR1 KMD18H-2VR1	Wall mounted: 7k/9k/12k/18k 4-way Cassette: 9k/12k/18k Ceiling Floor: 9k/12k/18k Slim Duct: 7k/9k/12k/18k	<table border="1"> <thead> <tr> <th>One Unit</th> <th>Two Units</th> </tr> </thead> <tbody> <tr> <td>7</td> <td>7+7 9+9</td> </tr> <tr> <td>9</td> <td>7+9 9+12</td> </tr> <tr> <td>12</td> <td>7+12 12+12</td> </tr> </tbody> </table>		One Unit	Two Units	7	7+7 9+9	9	7+9 9+12	12	7+12 12+12																		
		One Unit	Two Units																										
7	7+7 9+9																												
9	7+9 9+12																												
12	7+12 12+12																												
<b>1 drive 3</b> KMT24H-4VR1 KMT24H-2VR1	Wall mounted: 7k/9k/12k/18k 4-way Cassette: 9k/12k/18k Ceiling Floor: 9k/12k/18k Slim Duct: 7k/9k/12k/18k	<table border="1"> <thead> <tr> <th>One Unit</th> <th>Two Units</th> <th>Three Units</th> </tr> </thead> <tbody> <tr> <td>7</td> <td>7+7 9+12</td> <td>7+7+7 7+9+12</td> </tr> <tr> <td>9</td> <td>7+9 9+18</td> <td>7+7+9 7+12+12</td> </tr> <tr> <td>12</td> <td>7+12 12+12</td> <td>7+7+12 9+9+9</td> </tr> <tr> <td>18</td> <td>7+18 12+18</td> <td>7+7+18 9+9+12</td> </tr> <tr> <td></td> <td>9+9</td> <td>7+9+9 9+12+12</td> </tr> </tbody> </table>			One Unit	Two Units	Three Units	7	7+7 9+12	7+7+7 7+9+12	9	7+9 9+18	7+7+9 7+12+12	12	7+12 12+12	7+7+12 9+9+9	18	7+18 12+18	7+7+18 9+9+12		9+9	7+9+9 9+12+12							
		One Unit	Two Units	Three Units																									
7	7+7 9+12	7+7+7 7+9+12																											
9	7+9 9+18	7+7+9 7+12+12																											
12	7+12 12+12	7+7+12 9+9+9																											
18	7+18 12+18	7+7+18 9+9+12																											
	9+9	7+9+9 9+12+12																											
<b>1 drive 3</b> KMT27H-4VR1 KMT27H-2VR1	Wall mounted: 7k/9k/12k/18k 4-way Cassette: 9k/12k/18k Ceiling Floor: 9k/12k/18k Slim Duct: 7k/9k/12k/18k	<table border="1"> <thead> <tr> <th>One Unit</th> <th>Two Units</th> <th>Three Units</th> </tr> </thead> <tbody> <tr> <td>7</td> <td>7+7 9+12</td> <td>7+7+7 7+9+12</td> </tr> <tr> <td>9</td> <td>7+9 9+18</td> <td>7+7+9 7+12+12</td> </tr> <tr> <td>12</td> <td>7+12 12+12</td> <td>7+7+12 9+9+9</td> </tr> <tr> <td>18</td> <td>7+18 12+18</td> <td>7+7+18 9+9+12</td> </tr> <tr> <td></td> <td>9+9</td> <td>7+9+9 9+12+12</td> </tr> </tbody> </table>			One Unit	Two Units	Three Units	7	7+7 9+12	7+7+7 7+9+12	9	7+9 9+18	7+7+9 7+12+12	12	7+12 12+12	7+7+12 9+9+9	18	7+18 12+18	7+7+18 9+9+12		9+9	7+9+9 9+12+12							
		One Unit	Two Units	Three Units																									
7	7+7 9+12	7+7+7 7+9+12																											
9	7+9 9+18	7+7+9 7+12+12																											
12	7+12 12+12	7+7+12 9+9+9																											
18	7+18 12+18	7+7+18 9+9+12																											
	9+9	7+9+9 9+12+12																											
<b>1 drive 4</b> KMF36H-4VR1 KMF36H-2VR1	Wall mounted: 7k/9k/12k/18k/24k 4-way Cassette: 9k/12k/18k/24k Ceiling Floor: 9k/12k/18k/24k Slim Duct: 7k/9k/12k/18k/24k	<table border="1"> <thead> <tr> <th>One Unit</th> <th>Two Units</th> <th>Three Units</th> <th>Four Units</th> </tr> </thead> <tbody> <tr> <td>7</td> <td>7+12 12+12</td> <td>7+7+9 7+9+18 9+9+12 9+12+24</td> <td>7+7+7+7 7+7+9+9 7+9+9+9 9+9+9+12</td> </tr> <tr> <td>9</td> <td>7+18 12+18</td> <td>7+7+12 7+9+24 9+9+18 12+12+12</td> <td>7+7+7+9 7+7+9+12 7+9+9+12 9+9+12+12</td> </tr> <tr> <td>12</td> <td>7+24 12+24</td> <td>7+7+18 7+12+12 9+9+24 12+12+18</td> <td>7+7+7+12 7+7+9+18 7+9+9+18 9+9+12+18</td> </tr> <tr> <td>18</td> <td>9+18 18+18</td> <td>7+7+24 7+12+18 9+12+12 12+12+24</td> <td>7+7+7+18 7+7+12+12 7+9+12+12 9+12+12+12</td> </tr> <tr> <td>24</td> <td>9+24 18+24</td> <td>7+9+12 7+12+24 9+12+18 12+18+18</td> <td>7+7+7+24 7+7+12+18 7+12+12+12 12+12+12+12</td> </tr> </tbody> </table>				One Unit	Two Units	Three Units	Four Units	7	7+12 12+12	7+7+9 7+9+18 9+9+12 9+12+24	7+7+7+7 7+7+9+9 7+9+9+9 9+9+9+12	9	7+18 12+18	7+7+12 7+9+24 9+9+18 12+12+12	7+7+7+9 7+7+9+12 7+9+9+12 9+9+12+12	12	7+24 12+24	7+7+18 7+12+12 9+9+24 12+12+18	7+7+7+12 7+7+9+18 7+9+9+18 9+9+12+18	18	9+18 18+18	7+7+24 7+12+18 9+12+12 12+12+24	7+7+7+18 7+7+12+12 7+9+12+12 9+12+12+12	24	9+24 18+24	7+9+12 7+12+24 9+12+18 12+18+18	7+7+7+24 7+7+12+18 7+12+12+12 12+12+12+12
		One Unit	Two Units	Three Units	Four Units																								
7	7+12 12+12	7+7+9 7+9+18 9+9+12 9+12+24	7+7+7+7 7+7+9+9 7+9+9+9 9+9+9+12																										
9	7+18 12+18	7+7+12 7+9+24 9+9+18 12+12+12	7+7+7+9 7+7+9+12 7+9+9+12 9+9+12+12																										
12	7+24 12+24	7+7+18 7+12+12 9+9+24 12+12+18	7+7+7+12 7+7+9+18 7+9+9+18 9+9+12+18																										
18	9+18 18+18	7+7+24 7+12+18 9+12+12 12+12+24	7+7+7+18 7+7+12+12 7+9+12+12 9+12+12+12																										
24	9+24 18+24	7+9+12 7+12+24 9+12+18 12+18+18	7+7+7+24 7+7+12+18 7+12+12+12 12+12+12+12																										
<b>1 drive 5</b> KMV42H-4VR1 KMV42H-2VR1	Wall mounted: 7k/9k/12k/18k/24k 4-way Cassette: 9k/12k/18k/24k Ceiling Floor: 9k/12k/18k/24k Slim Duct: 7k/9k/12k/18k/24k	<table border="1"> <thead> <tr> <th>Three Units</th> <th>Four Units</th> <th>Five Units</th> </tr> </thead> <tbody> <tr> <td>7+7+12 7+9+24 9+9+24 12+12+18</td> <td>7+7+7+7 7+7+9+9 7+9+9+12 9+9+9+18 9+12+12+12</td> <td>7+7+7+7+7 7+7+7+9+9 7+7+7+12+18 7+7+9+9+12</td> </tr> <tr> <td>7+7+18 7+12+18 9+12+12 12+12+24</td> <td>7+7+7+9 7+7+9+12 7+9+9+18 9+9+9+24 9+12+12+18</td> <td>7+7+7+7+9 7+7+7+9+12 7+7+7+12+24 9+9+9+9+9</td> </tr> <tr> <td>7+7+24 7+12+24 9+12+18 12+18+18</td> <td>7+7+7+12 7+7+9+18 7+9+9+24 9+9+9+24 9+12+12+24</td> <td>7+7+7+7+12 7+7+7+9+18 7+7+9+9+12 7+7+9+9+18</td> </tr> <tr> <td>7+9+12 9+9+12 9+12+24 12+18+24</td> <td>7+7+7+18 7+7+12+12 7+9+12+12 9+9+12+12 12+12+12+12</td> <td>7+7+7+7+18 7+7+7+9+24 7+7+9+9+12 9+9+9+9+18</td> </tr> <tr> <td>7+9+18 9+9+18 12+12+12 18+18+18</td> <td>7+7+7+24 7+7+12+18 7+12+12+12 9+9+12+18 12+12+12+18</td> <td>7+7+7+7+24 7+7+7+12+12 7+7+9+9+18 9+9+9+12+18</td> </tr> </tbody> </table>					Three Units	Four Units	Five Units	7+7+12 7+9+24 9+9+24 12+12+18	7+7+7+7 7+7+9+9 7+9+9+12 9+9+9+18 9+12+12+12	7+7+7+7+7 7+7+7+9+9 7+7+7+12+18 7+7+9+9+12	7+7+18 7+12+18 9+12+12 12+12+24	7+7+7+9 7+7+9+12 7+9+9+18 9+9+9+24 9+12+12+18	7+7+7+7+9 7+7+7+9+12 7+7+7+12+24 9+9+9+9+9	7+7+24 7+12+24 9+12+18 12+18+18	7+7+7+12 7+7+9+18 7+9+9+24 9+9+9+24 9+12+12+24	7+7+7+7+12 7+7+7+9+18 7+7+9+9+12 7+7+9+9+18	7+9+12 9+9+12 9+12+24 12+18+24	7+7+7+18 7+7+12+12 7+9+12+12 9+9+12+12 12+12+12+12	7+7+7+7+18 7+7+7+9+24 7+7+9+9+12 9+9+9+9+18	7+9+18 9+9+18 12+12+12 18+18+18	7+7+7+24 7+7+12+18 7+12+12+12 9+9+12+18 12+12+12+18	7+7+7+7+24 7+7+7+12+12 7+7+9+9+18 9+9+9+12+18					
		Three Units	Four Units	Five Units																									
7+7+12 7+9+24 9+9+24 12+12+18	7+7+7+7 7+7+9+9 7+9+9+12 9+9+9+18 9+12+12+12	7+7+7+7+7 7+7+7+9+9 7+7+7+12+18 7+7+9+9+12																											
7+7+18 7+12+18 9+12+12 12+12+24	7+7+7+9 7+7+9+12 7+9+9+18 9+9+9+24 9+12+12+18	7+7+7+7+9 7+7+7+9+12 7+7+7+12+24 9+9+9+9+9																											
7+7+24 7+12+24 9+12+18 12+18+18	7+7+7+12 7+7+9+18 7+9+9+24 9+9+9+24 9+12+12+24	7+7+7+7+12 7+7+7+9+18 7+7+9+9+12 7+7+9+9+18																											
7+9+12 9+9+12 9+12+24 12+18+24	7+7+7+18 7+7+12+12 7+9+12+12 9+9+12+12 12+12+12+12	7+7+7+7+18 7+7+7+9+24 7+7+9+9+12 9+9+9+9+18																											
7+9+18 9+9+18 12+12+12 18+18+18	7+7+7+24 7+7+12+18 7+12+12+12 9+9+12+18 12+12+12+18	7+7+7+7+24 7+7+7+12+12 7+7+9+9+18 9+9+9+12+18																											







## Free Match-Indoor Units

### Specification-Ceiling&Floor



Model	Indoor unit	50Hz	KMNE09H-4VR1	KMNE12H-4VR1	KMNE18H-4VR1
		60Hz	KMNE09H-2VR1	KMNE12H-2VR1	KMNE18H-2VR1
Capacity	Cooling/Heating	Btu/h	9560(5120-12115)/10240(5460-13000)	12285(5800-12625)/14670(6930-15080)	17400(8530-19780)/24570(11840-27415)
		kW	2.80(1.50-3.55)/3.00(1.60-3.81)	3.60(1.70-3.70)/3.90(2.03-4.42)	5.30(2.50-5.80)/5.80(3.47-8.04)
Electric Data	Power Supply	V-,Hz,Ph	220-240,50,1	220-240,50,1	220-240,50,1
		Cooling/Heating Power Input	W	80(20-125)/80(20-125)	80(20-125)/80(20-125)
Performance	Air Flow Volume	m <sup>3</sup> /h	620	620	850
		Noise Level	dB(A)	39/36/30	39/36/30
Dimension (WxDxH)	Net	mm	929 × 660 × 205	929 × 660 × 205	929 × 660 × 205
		Packing	mm	1010 × 720 × 290	1010 × 720 × 290
Weight	Net/Gross	kg	24/27	24/27	25/28
		Liquid Side	mm(inch)	6.35(1/4)	6.35(1/4)
Piping size	Gas Side	mm(inch)	12.7(1/2)	12.7(1/2)	12.7(1/2)
		Drainage	mm(inch)	DN20(R3/4)	DN20(R3/4)
Stuffing Quantity	20/40/40H	unit	136/280/315	136/280/315	136/280/315

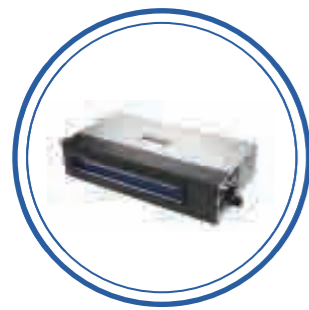

## Free Match-Indoor Units

### Specification-Slim Duct



Model	Indoor unit	50Hz	KMNS07H-4VR1	KMNS09H-4VR1	KMNS12H-4VR1	KMNS18H-4VR1
		60Hz	KMNS07H-2VR1	KMNS09H-2VR1	KMNS12H-2VR1	KMNS18H-2VR1
Capacity	Cooling/Heating	Btu/h	7506(3855-9220)/8530(4575-10820)	9560(5120-12115)/10236(5800-12450)	12280(5835-13135)/12965(6480-13375)	19110(8530-19790)/20470(9690-21835)
		kW	2.20(1.13-2.70)/2.50(1.34-3.17)	2.80(1.50-3.55)/2.90(1.70-3.65)	3.60(1.71-3.85)/4.00(1.90-3.92)	5.10(2.50-5.80)/5.80(2.84-6.40)
Electric Data	Power Supply	V-,Hz,Ph	220-240,50,1	220-240,50,1	220-240,50,1	220-240,50,1
		Cooling/Heating Power Input	W	45/45	45/45	75/75
Performance	Air Flow Volume	m <sup>3</sup> /h	420	420	580	860
		Noise Level	dB(A)	30/26/23	30/26/23	32/28/25
Dimension (WxDxH)	ESP	Pa	10/30	10/30	10/30	10/30
		Net	mm	840 × 460 × 185	840 × 460 × 185	840 × 460 × 185
Weight	Net/Gross	kg	16.5/20	16.5/20	17.5/21	21/26
		Liquid Side	mm(inch)	6.35(1/4)	6.35(1/4)	6.35(1/4)
Piping size	Gas Side	mm(inch)	9.52(3/8)	9.52(3/8)	12.7(1/2)	12.7(1/2)
		Drainage	mm(inch)	16.5(3/5)	16.5(3/5)	16.5(3/5)
Stuffing Quantity	20/40/40H	unit	198/396/440	198/396/440	198/396/440	144/297/330

\* Remark: The above designs and specifications are subject to change without prior notice. Final specifications please refer to technical specification provided by sales representative.

## Control System

Remote Controller	-----	177
Wired Controller	-----	179
Centralized Controller	-----	180

## Network Control Software

Centralized Controller Software	-----	183
Billing System	-----	184
BMS System	-----	186
Wireless Network Control	-----	187

## Accessories

AHU Kit	-----	189
Selection Software	-----	191
Monitoring Software	-----	192

# Control System

## Remote Controller



## Wired Controller



## Centralized Controller

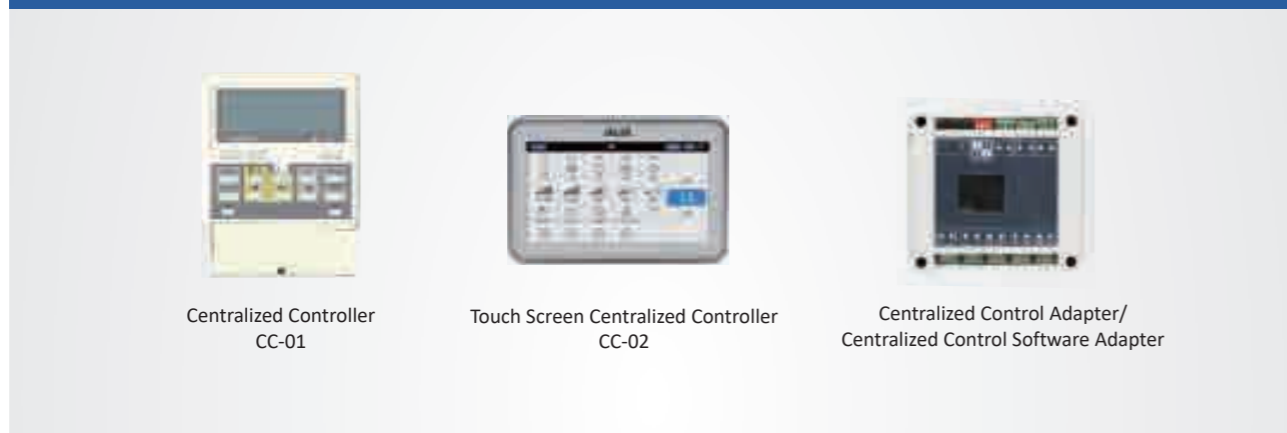

# Remote Controller

YK-L

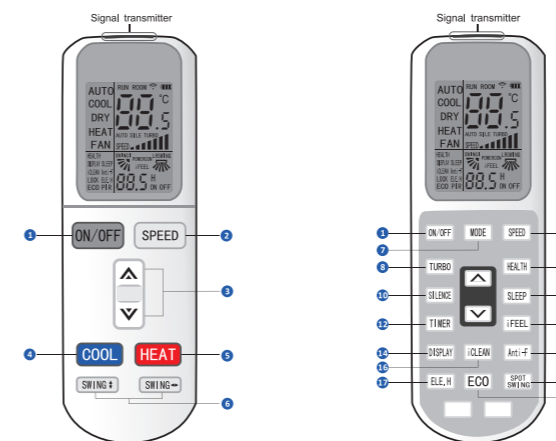

- 1 ON/OFF
- 2 Fan Speed Setting HIGH/MED/LOW/AUTO
- 3 Temperature-Setting /Timer Range Setting
- 4 Cooling Mode
- 5 Heating Mode
- 6 Vertical Swing/Horizontal Swing
- 7 Mode Setting AUTO/COOL/DRY/HEAT/FAN
- 8 Turbo Wind
- 9 Health Function
- 10 Silence Function
- 11 Sleep Function
- 12 Timer On/Off
- 13 I Feel Function
- 14 LED Display On/Off
- 15 Anti-fungus Function
- 16 Clean Function
- 17 Auxiliary Electric Heating
- 18 Spot Swing
- 19 Economic Function

YK-K

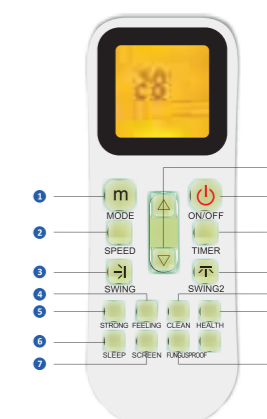

- 1 Mode Setting AUTO/COOL/DRY/HEAT/FAN
- 2 Fan Speed Setting HIGH/MED/LOW/AUTO
- 3 Vertical Swing
- 4 Feeling Function
- 5 Strong Wind
- 6 Sleep Function
- 7 LED Display On/Off
- 8 Temperature-Setting /Timer Range Setting
- 9 ON/OFF
- 10 Timer On/Off
- 11 Horizontal Swing
- 12 Clean Function
- 13 Health Function
- 14 Fungusproof Function

## » Function

### 1. Background light

The background light allows users to operate the controller in a dark room. The device lights up when a button is pressed, and turns off when a given operation is completed.

### 2. Setting addresses

Besides the machine's auto addressing function, users can set the indoor unit's address on the remote controller YK-L.

## » Specifications

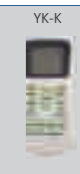
	YK-L	YK-K
Model		
Dimension (WxHxD) (mm)	52x160x25(max)	50x140x28.5(max)
Power(V)	3V(1.5V×2)	3V(1.5V×2)

# Wired Controller

XK-02A



XK-05



## » Function

### 1. Remote signal receiving function

Wired controller provide a signal receiver for remote controller. Signal from remote controller can be received by wired controller, then sent to the indoor unit and it's convenient to control.

### 2. Setting addresses

The address setting function is coupled with easy installation and simple future maintenance. Service personnel can set the address for the indoor unit using XK-02A and XK-05A.

### 3. Keyboard locking

The locking function can be used to prevent other people from using the controller.

### 4. Easy connection

The wired controller conveniently connects to the indoor unit's display panel via connecting wire.

## » Specifications

Model	XK-02A	XK-05A
Dimension (WxHxD) (mm)	120x120x18(max)	86x86x18(47)
Power(V)	12V	12V

# Centralized Controller



- Quick on/off
- Set /change time
- Timer Mode: a. Current/Daily Timing; b. Weekly Timer
- Zone/Unit Set; Zoned Control
- Centralized Control and Lock Functions
- Failure Inquiry Function

### Accessory: Centralized Controller Adaptor



**Function:** Centralized controller adaptor is used with centralized controller together.

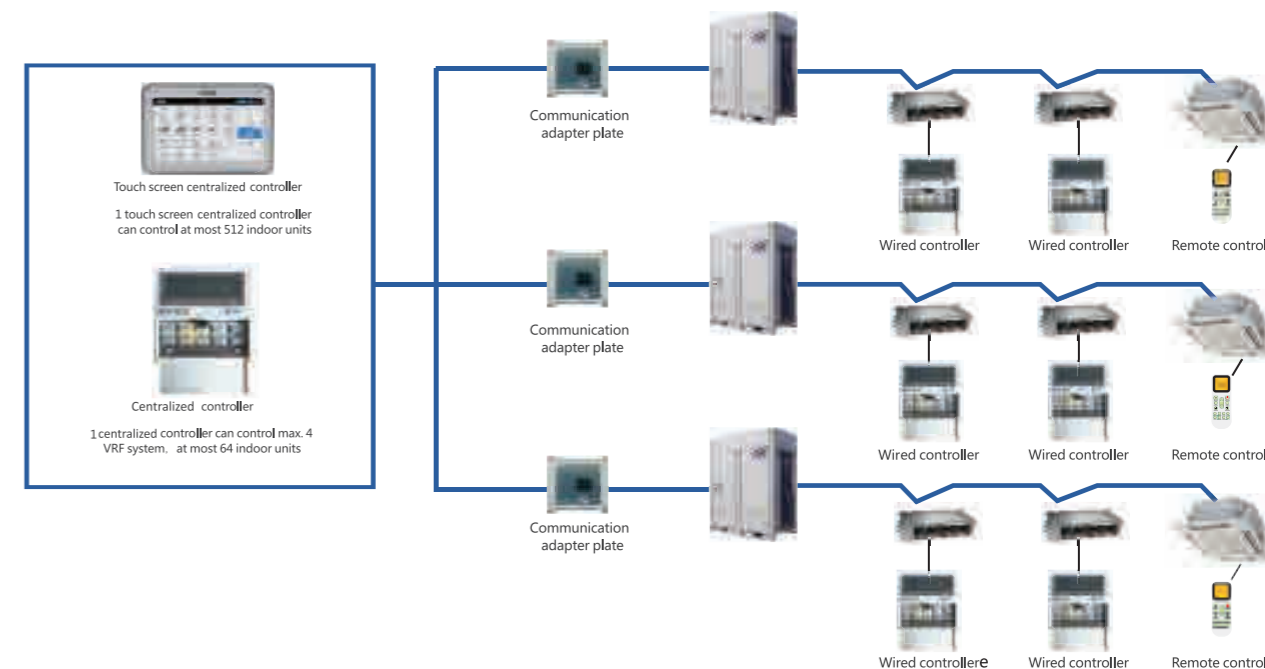

## » Function

1. Operation status of as many as 512 indoor units can be monitored , including wind speed, set temperature, etc.
2. Mode, air speed and temperature setting are possible for individual/zoned/all indoor units.
3. 3 operation modes are available: Last-in Preferred, Centralized Control and Lock;
4. The malfunctions of the indoor units can be monitored and saved for inquiry;
5. Timed on/off is possible by specifying the exact time or by weekly schedule.
6. Any number of centralized units can be zoned with as many as 63 indoor units (central controller) & 511 indoor units (touch screen central controller) set as one zone, so that units in the same operation. (As the factory default, a centralized group is considered as a zone)

## » Specifications

Model	CC-01	CC-02
Dimension (WxHxD) (mm)	120x120x18.5(max)	Coming Soon

# Network Control Software

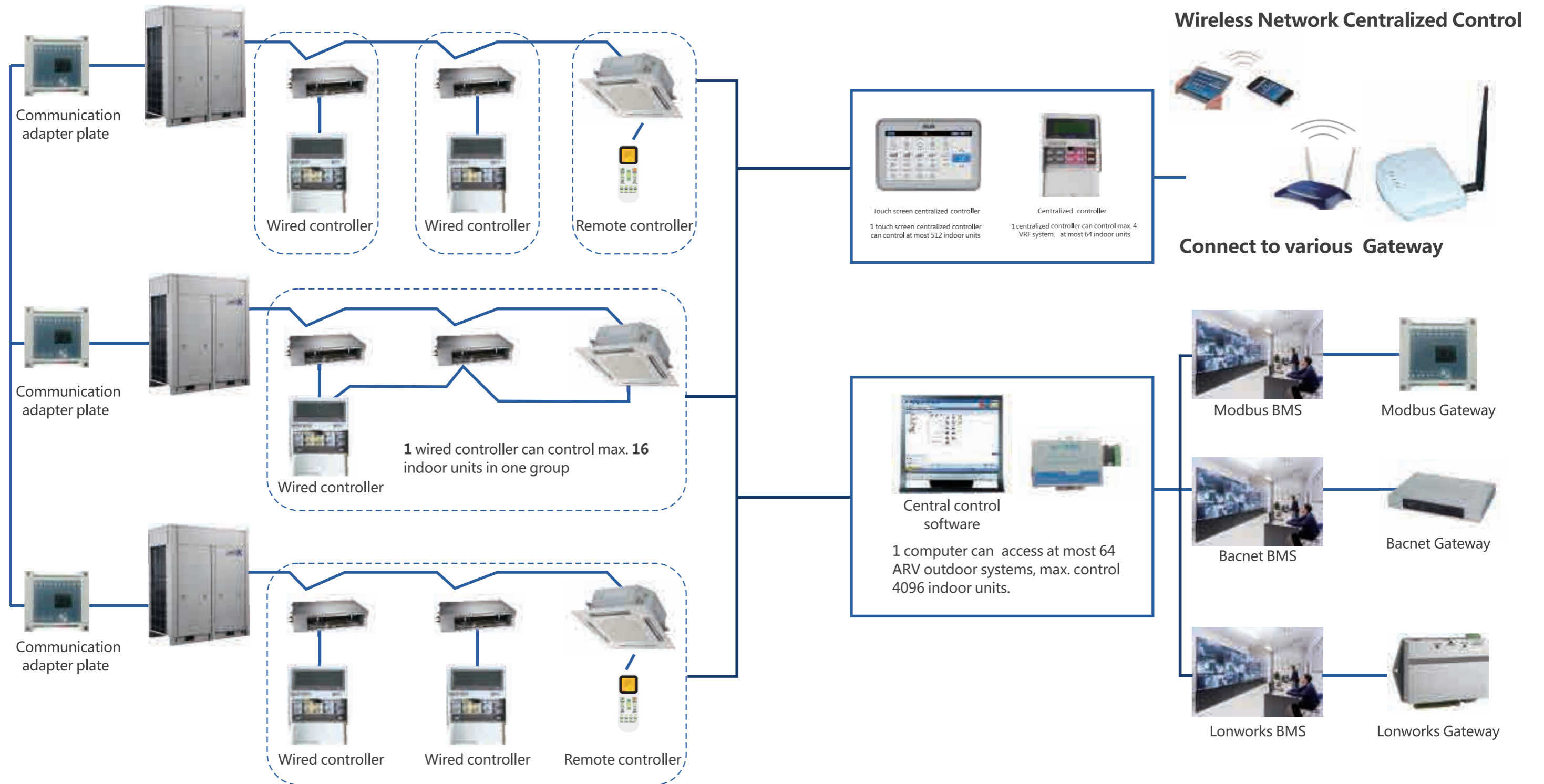

# Central Control of Light Commercial

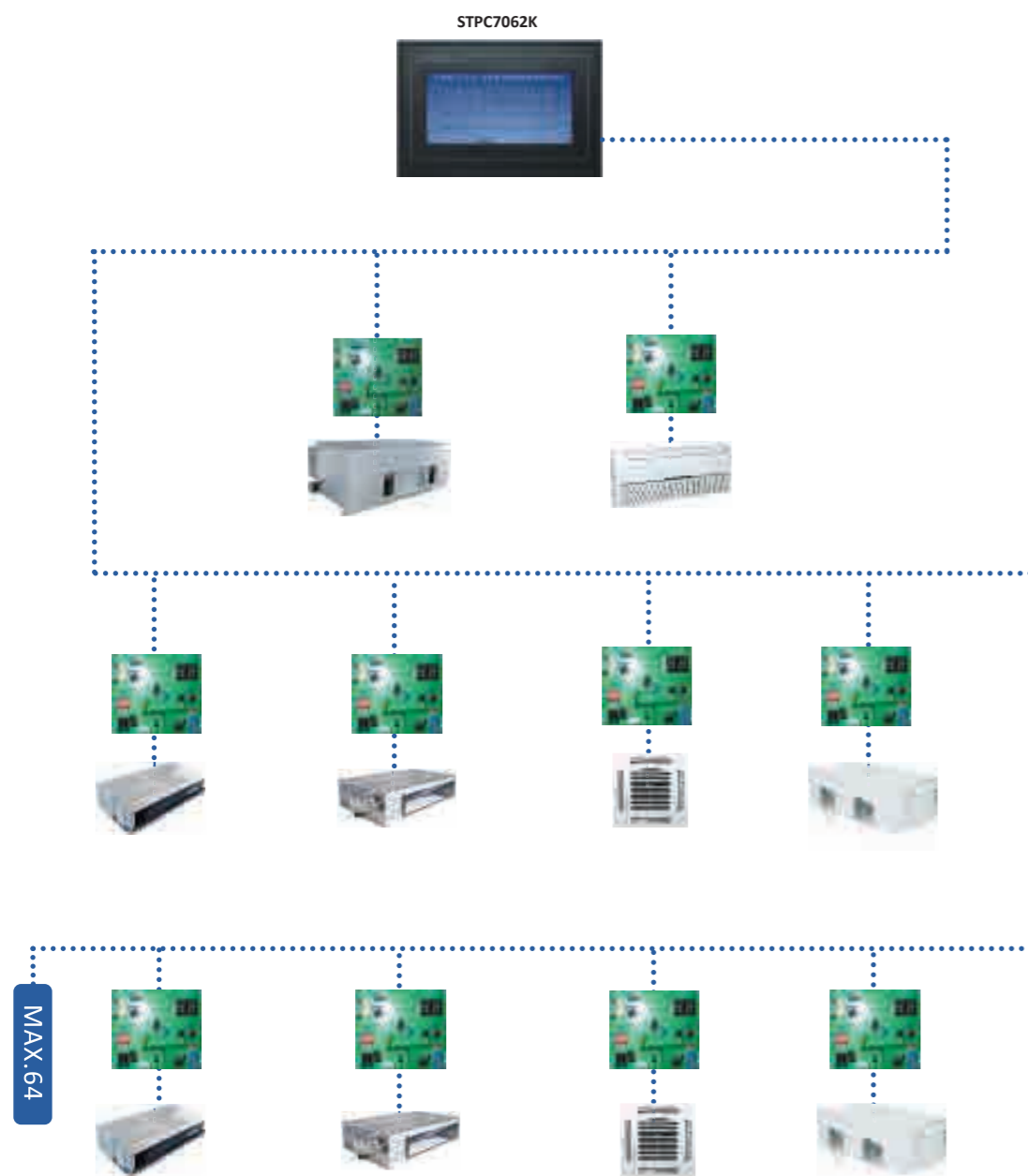

- 1.TPC7062KS can be used to centrally control up to 64 indoor units.
- 2.The indoor units can be divided into a maximum of 20 zones, each zone can be assigned no more than 64 units. You can set the indoor units of same zone in the same operation mode (default is "no zone").
- 3.Weekly schedule: TPC7062KS can include up to 64 indoor units in the weekly schedule, users can select the desired running mode and room temperature. The operation object can be a single indoor unit, a zone or all the indoor units.
- 4.TPC7062KS can display the error codes and running status of indoor unit, so users can easily identify faults via checking the error codes table in user's manual.

# Network Control Software-Centralized Controller Software

## » System Overview

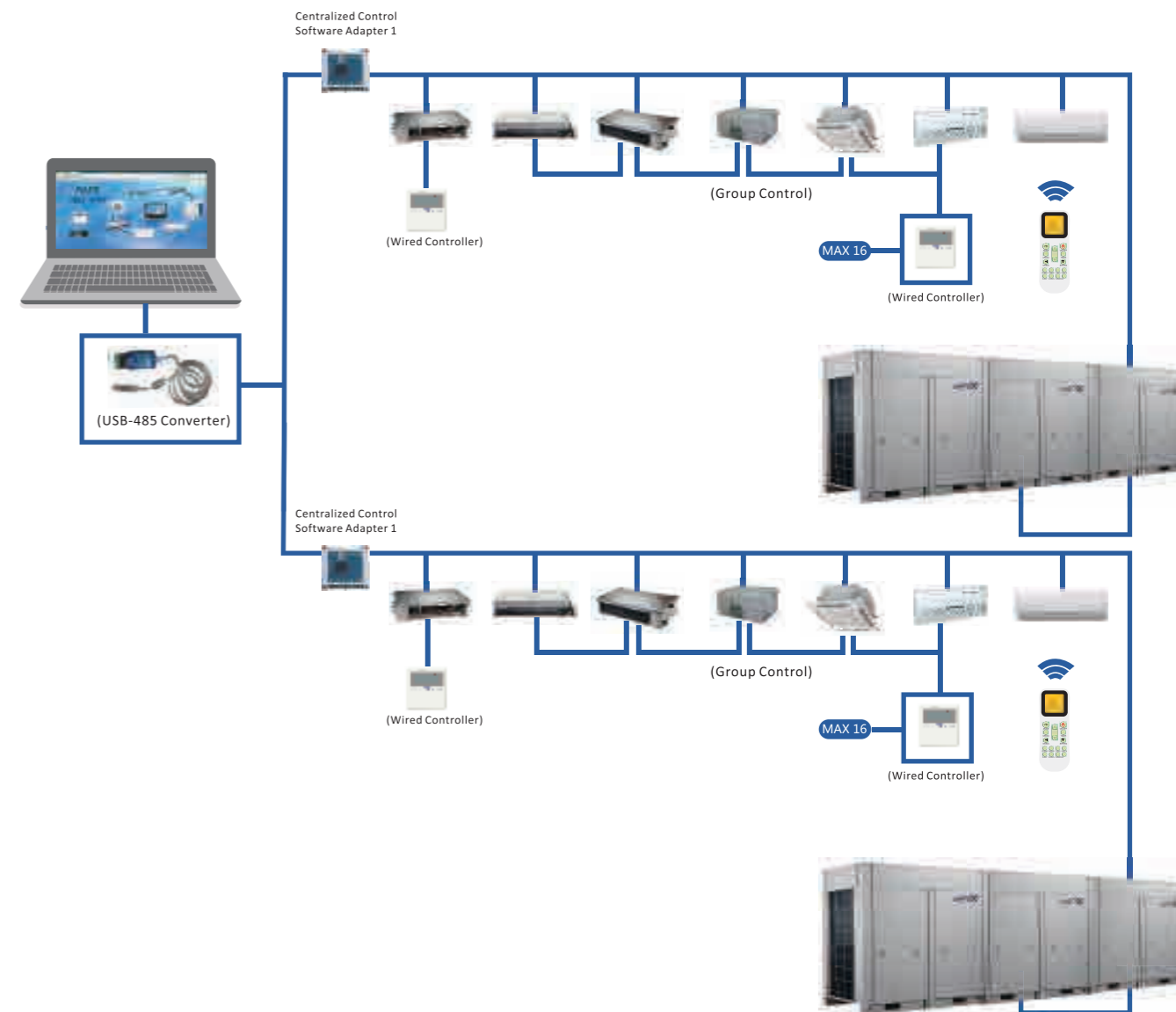

## » Features

- Users do not need to arrive the harsh environment of the site, they can monitor the function of units just through computer. These greatly improve convenience of daily management and the efficiency of central air conditioners;
- Timely find the fault and save the maintenance cost of air conditioner units, minimize losses ;
- Timer function with multi-period week, fully automated schedule planning of unit;
- Each KRV unit can access at most 63 indoor sets;
- This system can access at most 64 KRV outdoor systems, it need to access repeater to increase RS485 network equipment if the outdoor systems are more than 64.

## Network Control Software-Centralized Controller Software

### » Main Components Of Centralized Controller System

No	Main Components	Required
1	Host Computer	Operation system: Windows XP SP2 and above, Windows 7
2	Communications adapter plate	Computer and communication protocol and unit end communication protocol are incompatible with each other, must add communication adapter plate to make both communicate.
3	RS-232 to RS-485/422 converter	The centralized control system RS485 network signal conversion for RS232 serial signal to achieve the interconnection of computers with centralized control system.
	USB to RS-485/422 converter	The centralized control system RS485 network signal conversion for USB to achieve the interconnection of laptops with centralized control system.
4	RS-485/422 Repeater	Extend the communication distance and increase the number of RS-485 bus network. The repeater is not required, only when there is more than 64 communications equipment or communication distance is more than 800 meters.

### » Software Introduction Main Interface

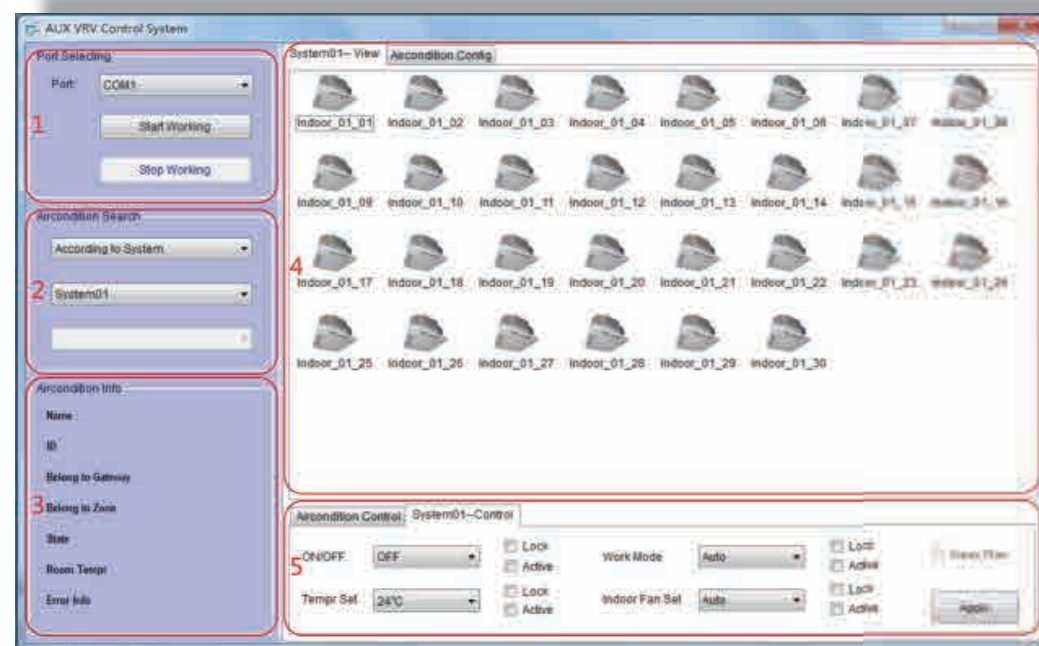

- Area 1** -- Serial setting area, choose the serial and press "Start Working" button, system will in operation, press "Stop Working" button, system will stop working;
- Area 2** -- The inquire area for air conditioner unit, it can be divided into the system inquire and user-defined group inquire, the inquired unit will be displayed in area 4.
- Area 3** -- Display area of single air conditioner indoor unit, select one of indoor units in area 4, then the area will display the name, ID (address of indoor unit), system belonged, group belonged, current condition, the room temperature of indoor unit, failure etc.
- Area 4** -- Display area of air conditioner group, as shown in above picture, it displayed all the indoor units in the group System01.
- Area 5** -- Control area of air conditioner, it can control one single air conditioner and some air conditioner group, this will be described in detail later.

## Network Control Software-Billing System

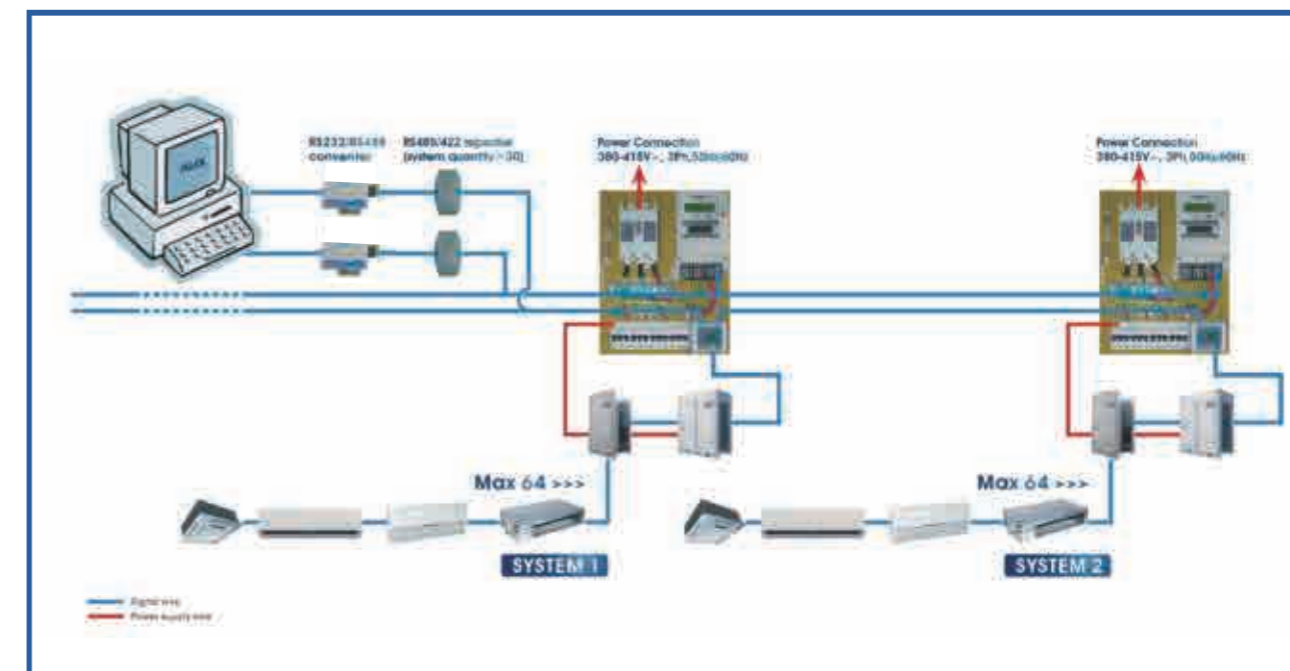

- At most 99 outdoor systems and 1024 indoor units.
- Real-time monitor for indoor units(ON/OFF, Error);
- Variable Control Type(Individual Control/ Air-System Control/ Group Control & Schedule);
- The Operation History(Error, Turn on/off-time);
- Lock the indoor units when arrear occurs;
- The PPD(Power Proportional Distribution) outputs bill by day with PDF-format report;

### » Software Interface



### » Configuration

Modbus style	Baudrate	Data-Bit	Stop-Bit	Check	Slave-ID range	Modbus code	Support broadcast
MODBUS-RTU	9600	8	1	even	1~64	01,02,03,04,05,06	NO

# Network Control Software-BMS System

## » Overall structure

### Modbus

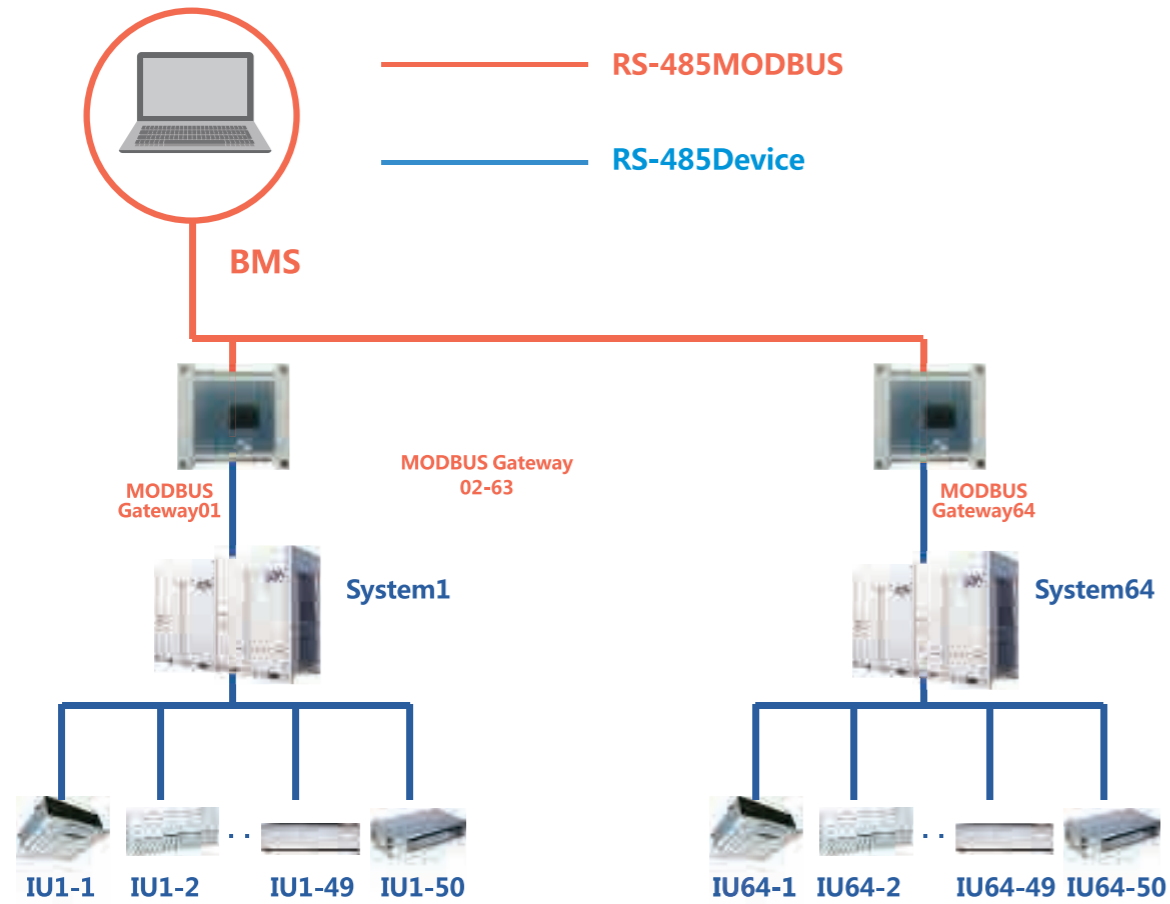

### Lonworks

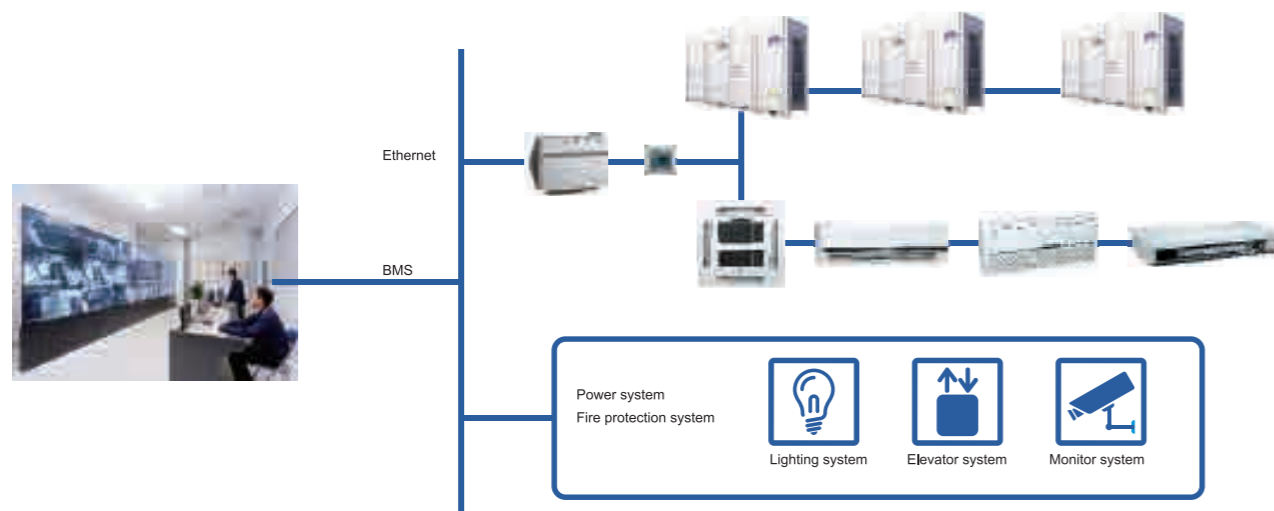

# Network Control Software-Wireless Network Control System

## » Mixed connected with other indoor units

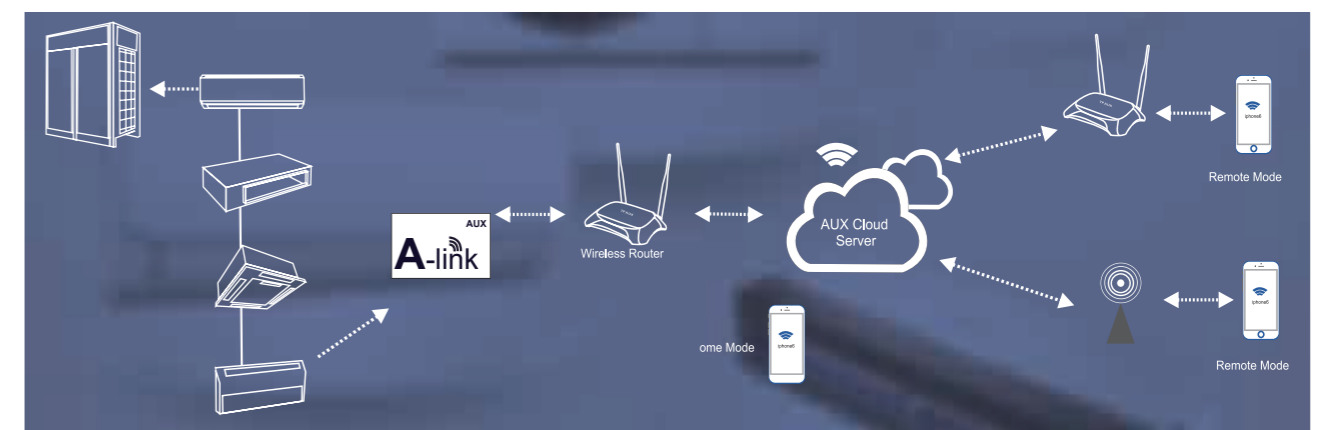
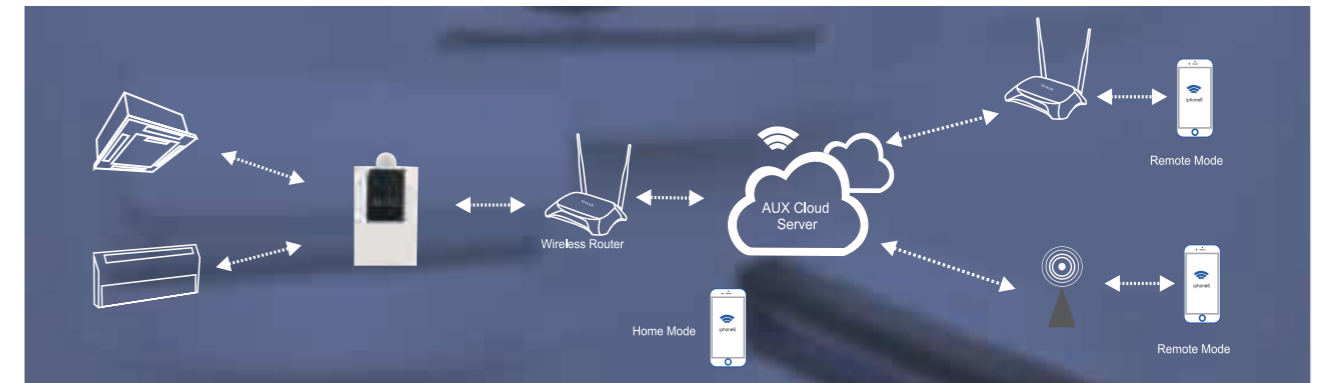

## » Features

1. AUKIA air conditioner can connect to intelligent terminal through WIFI or GPRS network, customers can enjoy fun and convenience of remote control the AC via iphone, ipad and other mobile terminals(Android and IOS) to control the AC at anytime and anywhere.
2. The function of software on Mobile terminal includes mode control, temperature control, swing control, timing control.
3. Customers can set schedule to plan their day, also the scene mode can be set conveniently.

## Accessories-AHU Kit

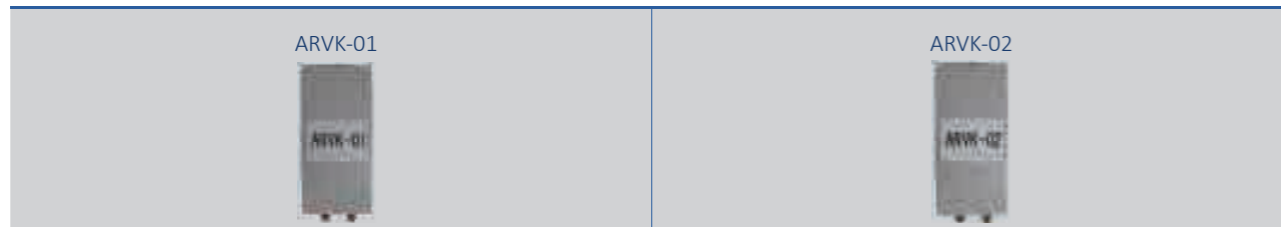

### » Wiring Example

#### Partial fresh air system

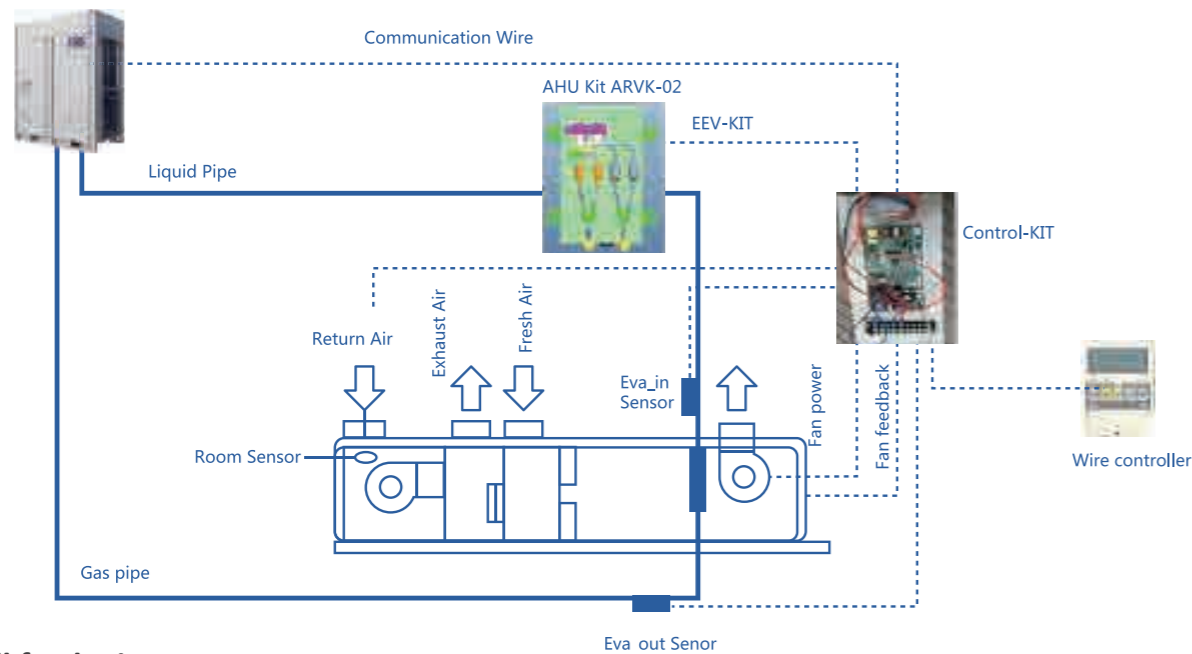

#### All fresh air system

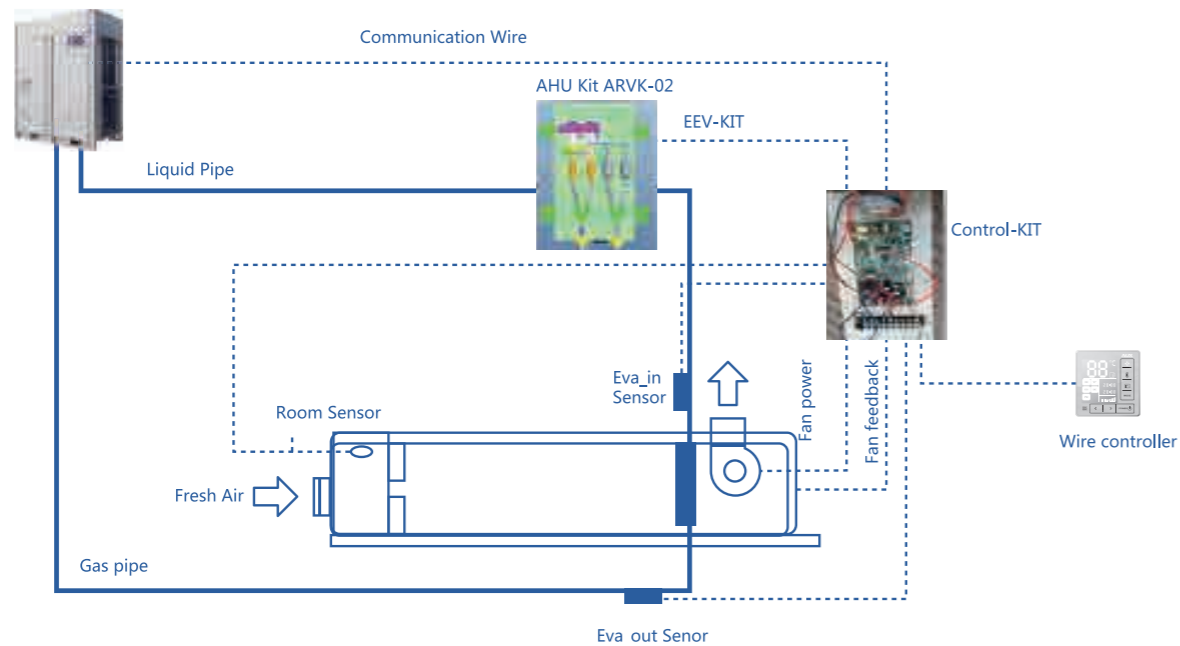

## Accessories-AHU Kit

### » Structure Diagram

#### Mixed connected with other indoor units

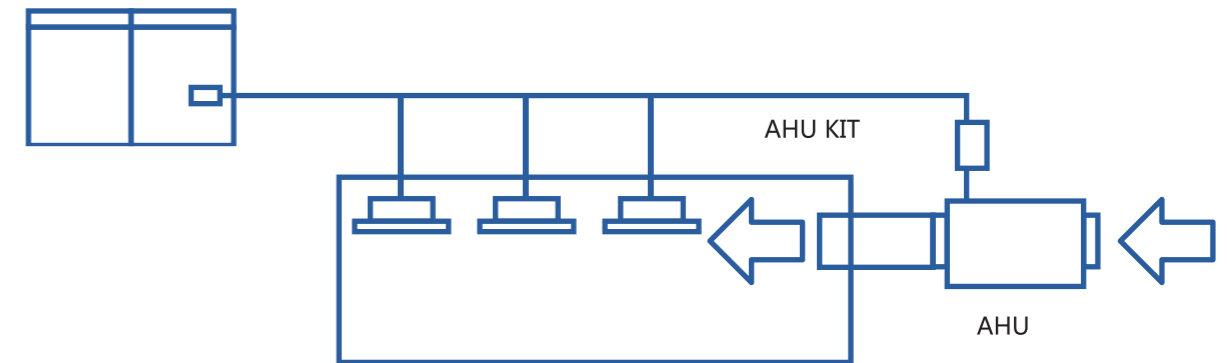

#### Individually connected with ODU

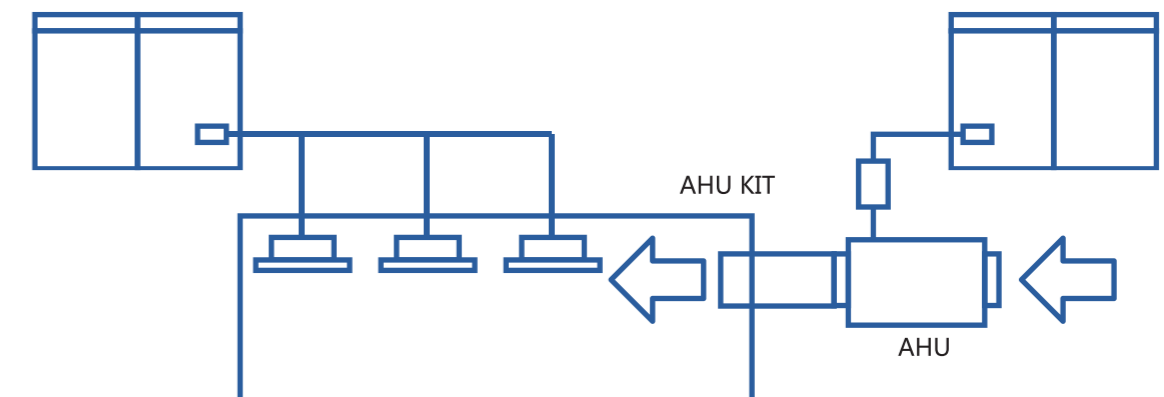

### » Specifications

AHU Kit Mode	Allowed heat exchanger capacity	Power(V~,Hz,Ph)	Air Flow Volume (m <sup>3</sup> /h)		Weight(kg)		Dimension(WxDxH)(mm)
			Min	Max	Net	Gross	Packing
KRVK-01	≤10HP	220~240,50,1	2500	5000	5.7	7.2	450×430×160
KRVK-02	≤20HP	220~240,50,1	5000	9000	6	7.5	450×430×160



## Accessories-Selection Software

To meet the customers' requirements, AUKIA has developed the advanced selection software. The software provides quick and convenient selectable options for users, supports multiple languages, greatly improves the selection and installation process.

### » 6 Parts Of The KRV Selection

No	Steps	Instruction
1	Selecting indoor units	Selecting indoor unit for project according the capacity, air flow volume and room information.
2	Selecting outdoor units	Automatic selection suitable outdoor unit for project according to the capacity of indoor units, the capacity ratio between indoor and outdoor unit, and the temperature of indoor and outdoor unit.
3	Drawing piping diagram	Every outdoor system can draw corresponding piping diagram. The system will auto select branch pipe, gas pipe and liquid pipe according to selected indoor and outdoor unit. The pipe length can be input according to the project diagram if the project need. Ability compensation also can be displayed for the software.
4	Drawing wiring diagram	Every outdoor system can draw wiring diagram. The wiring length can be input according to the project diagram if the project need. Wring includes: power cable, signal cable and so on. Remote controller and wired controller can be chosen according to the customer's demands.
5	Selecting BMS or Centralized Controller	The software can be used to select either BMS or centralized controller and draw connecting wiring diagram.
6	Output the report	The report can be output in 3 kinds of forms, PDF, word and CAD.

### » The Result As Below

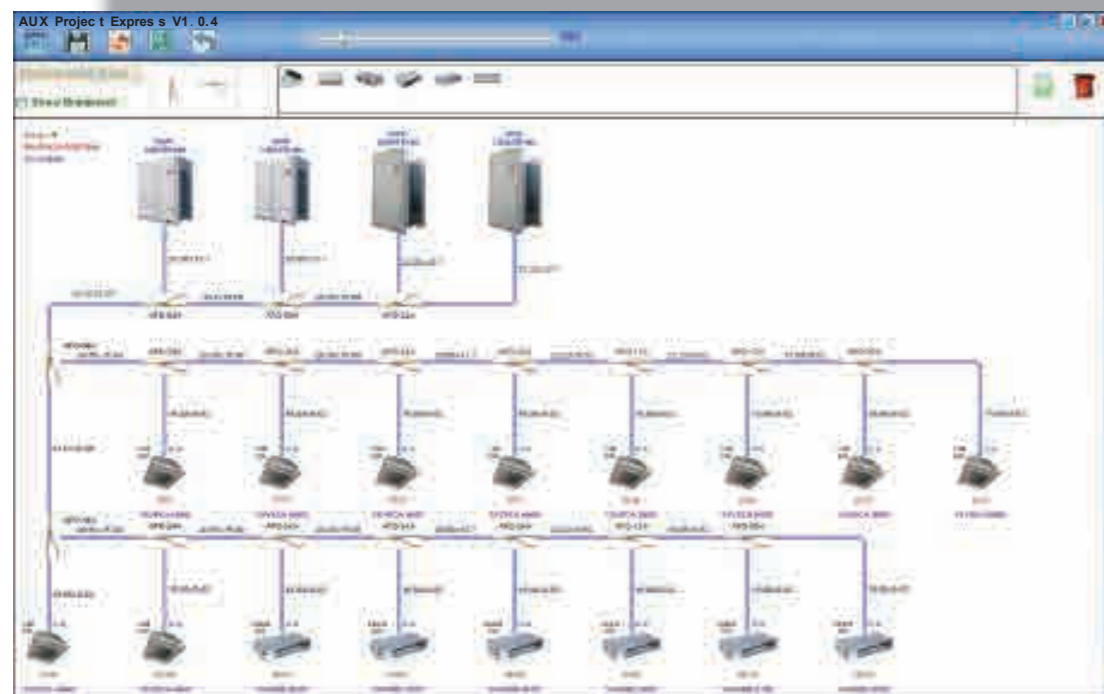

## Accessories-Monitoring Software

Self-diagnosis software can be used as remote controller, it is recommended for commissioning. It can monitor the running state of the outdoor and indoor units real time. And display the malfunctions, be convenient to do the commissioning and trouble-shooting work.

