

2	Auxiliary Output Groups	0: standard, 2 groups output, no auxiliary output 1: 1 group auxiliary output. Not available now. 2: 2 groups auxiliary output. Not available now.
3	4 Optional	00: standard 01: CT input. Not available now. 02: Event input. Not available now.
5	Main Output Type	R: Relay output SPST, 250VAC, 3A V: Voltage Pulse output 12V +10% ~-20% C: Current output 4~20mA L: Linear Voltage output 0~10V

※ Standard: DC24V input, Relay output for 2nd group, RS-485 communication.

3	FUNCTION AND SPECIFICATION
----------	-----------------------------------

Power Supply	DC24V. Isolated switching power
Voltage Range	Rated voltage: 90%~110%
Power consumption	Rated 24 Vdc, Max. 24 W combined, 3 W + 3 W x no. of DTC-2000 (max. 7 connected)
Sensor Type	Thermocouple: K, J, T, E, N, R, S, B, L, U, TXK
	Platinum RTD: Pt100, JPt100
	Linear DC input: 0~5V, 0~10V, 0~ 20 m A, 4~20 m A, 0~50mV
Sampling Rate	Analog input: 0.15 sec. Thermocouple or Platinum RTD: 0.4 sec.
Control Method	PID , PID program control, Manual or ON/OFF
Output Type	Relay output (SPST), Max. load 250VAC, 3A resistive load
	Voltage pulse output: DC 12V, Max. output current 40mA
	Current output: DC 4 ~ 20m A output (Load resistance: Max. 500Ω)
	Analog voltage output: 0~10V (Load resistance shall be higher than 1000Ω)
Output Function	Control output, Alarm output, or Retransmission output (only for linear voltage and current output as 1 st group)
Alarm Function	12 Alarm mode selections
Communication	RS-485 digital communication, 2400bps~38400bps.
Communication Protocol	Mod-bus communication protocol, support RTU/ASCII.
Internal Connection	Provide internal connection terminals to transmit 24V power supply and communication signal.
Vibration Resistance	10 to 55Hz, 10m/s ² for 10min, each in X, Y and Z directions
Shock Resistance	Max. 300m/ s ² , 3 times in each 3 axes, 6 directions
Ambient Temperature	0 °C to +50 °C
Storage Temperature	-20 °C to +65 °C
Altitude	2000m or less
Relative Humidity	35% to 85% RH (non-condensing)
Pollution Degree	Degree 2

4

PRODUCT PROFILE AND OUTLINE

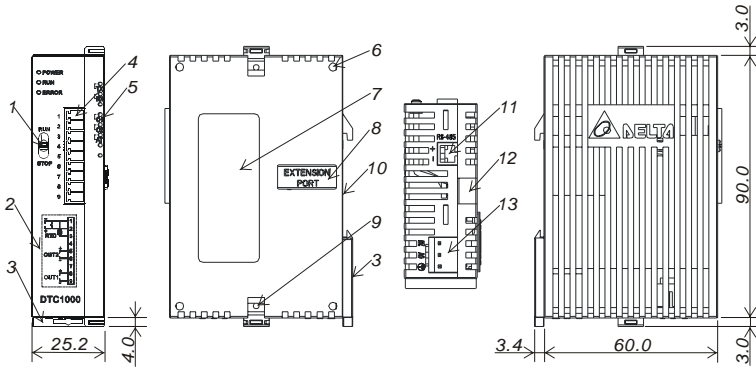

DTC1000R/V/C/L

1. RUN/STOP switch
2. Wiring and Model name
3. DIN fix
4. I/O terminals
5. LED indicators
6. Extension hole of the extension unit mounting pins
7. Specification label
8. Extension port
9. Extension clip
10. DIN rail
11. RS-485 communication port
12. Extension clip
13. DC power input

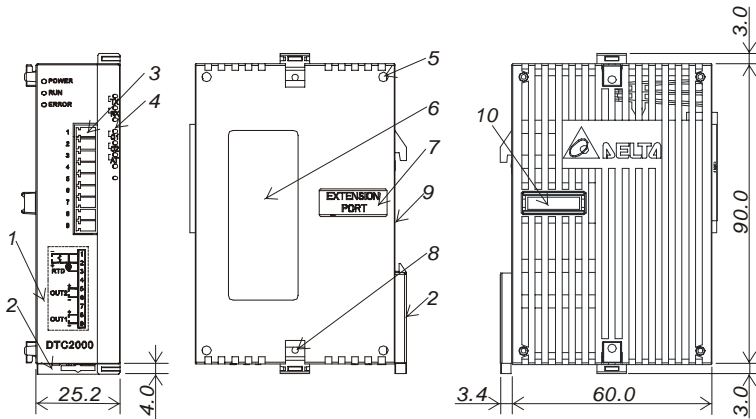

DTC2000R/V/C/L

1. Wiring and Model name
2. DIN rail clip
3. I/O terminals
4. LED indicators
5. Extension hole of the extension unit mounting pins
6. Specification label
7. Extension port
8. Extension clip
9. DIN rail
10. Extension port

5

INPUT SENSOR TYPE

Input Selection for DTC series:

Input Sensor Type	Register Value	Available Range
0~50mV Linear Voltage Input	17	0~50mV
4~20mA Linear Current Input	16	4~20mA
0~20mA Linear Current Input	15	0~20mA
0~10V Linear Voltage Input	14	0~10V
0~5V Linear Voltage Input	13	0~5V
Platinum RTD (Pt100)	12	-200 ~ 600°C (-328~1112°F)
Platinum RTD (JPt100)	11	-20~ 400 °C (-4~752 °F)
Thermocouple TXK type	10	-200~800 °C (-328~1472°F)
Thermocouple U type	9	-200~500 °C (-328~932°F)
Thermocouple L type	8	-200~850 °C (-328~1562°F)
Thermocouple B type	7	100 ~ 1800 °C (212~3272°F)
Thermocouple S type	6	0 ~ 1700 °C (32~3092°F)
Thermocouple R type	5	0 ~ 1700 °C (32~3092°F)
Thermocouple N type	4	-200 ~ 1300 °C (-328~2372°F)
Thermocouple E type	3	0 ~ 600 °C (32~1112°F)
Thermocouple T type	2	-200 ~ 400 °C (-328~752°F)
Thermocouple J type	1	-100 ~ 1200 °C (-148~2192°F)
Thermocouple K type	0	-200 ~ 1300 °C (-328~2372°F)

Note 1: an external 250Ω precision resistor is needed for current input.

Note 2: factory setting: PT100 input. It is adjustable for linear input and feedback ranges. The default range of input feedback is -999~9999. For example, when a 0~20mA analog input is selected as the input temperature sensor type, -999 indicates 0mA and 9999 indicates 20mA. If change the input range to 0 ~ 2000, then 0 indicates 0mA and 2000 indicates 20mA. One display scale is equal to 0.01mA.

6 OUTPUT FUNCTION

Output control for DTC is selective: Control output (heating, cooling), Alarm output, or Retransmission output.

Control Output:

Temperature can individually be controlled by two groups outputs: cooling (forward) or heating (reverse). When Dual Loop output control is used, two output controls shall be designed for cooling (forward) or heating (reverse). If two control outputs with the same direction are performed, only 1st group control period is valid. Control methods: PID control, ON/OFF control, Manual control, and PID program control.

Single-output Control:

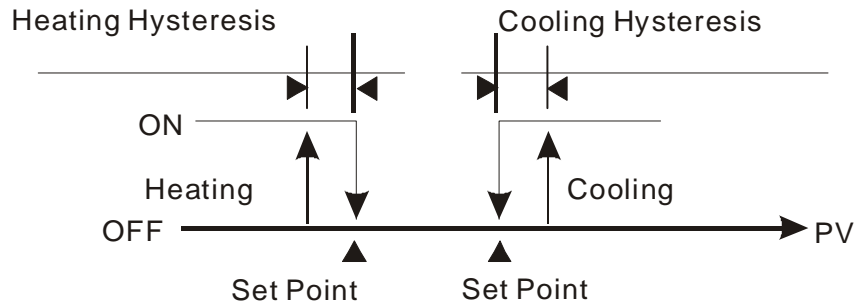

Figure1: ON-OFF control of single output

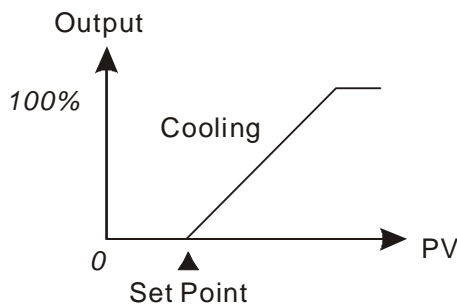

Figure 2: PID Control, forward (cooling) control

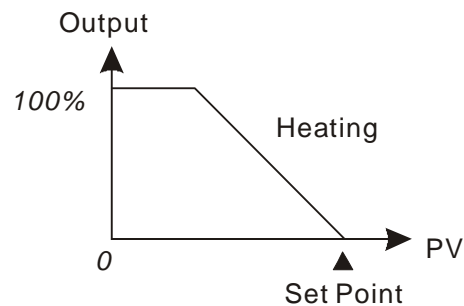

Figure 3: PID Control, reverse (heating) control

Dual Output Control:

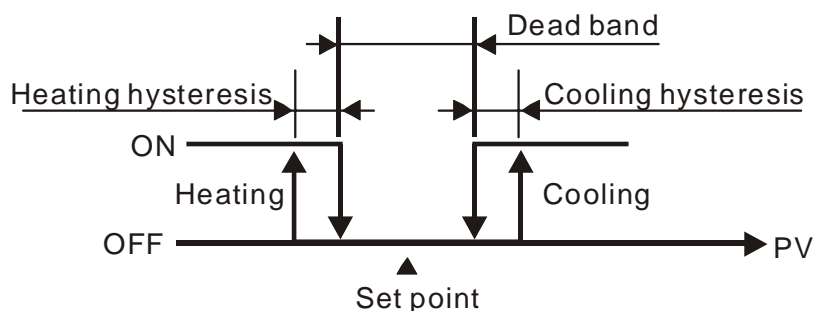

Figure 4. ON-OFF control of dual loop output

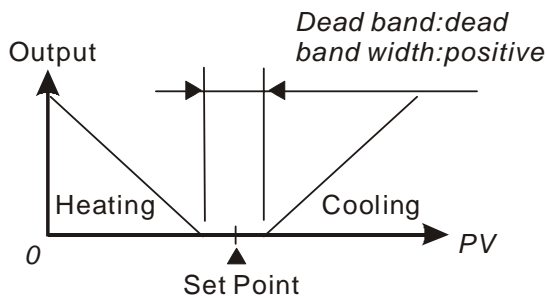

Figure 5: PID control,
Dead band is positive

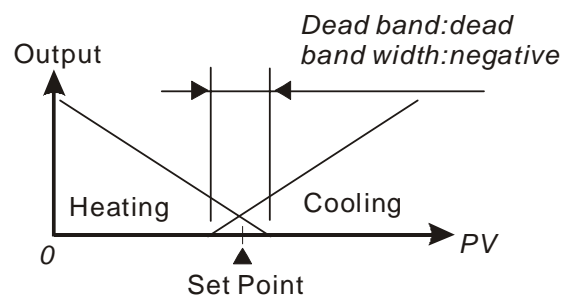

Figure 6: PID control,
Dead band is negative

Description of Function and Parameters Setting:

PID program control by 8 patterns (Pattern No. 0~7) is supported in DTB series. Each pattern contains 8 steps (step No. 0 ~ 7), one Link Pattern parameter, one Cycle parameter and one Actual Step parameter

Start Pattern: `Ptcrn` is in operation mode and it is used to set the Start Pattern of PID program control (This parameter appear in `PStP` mode only).

Steps: Include set point X and execution time T, these two parameters setting. The set point (SV) should reach temperature X after the period of execution time T. If the set point is the same as the result of the previous setting, then it is called Soak program control. If not, then it is called Ramp program control. Therefore, PID program control is also called Ramp/Soak program control. The default of step No. 0 in this controller is Soak program control. The controller will control the temperature (PV) to reach the set point X and then keep the temperature at set point X. The period of execution time is time T which provided by step No. 0.

Link Pattern Parameter: For example, when set `Ln0` to 2, it indicates that pattern No. 2 will execute next after the execution of pattern No. 0. If set to `off`, it indicates the program will stop after executing the current pattern and the temperature will keep at the set point of the last step.

Cycle Parameter: Additional execution cycle number. For example, when set `CYC4` to 2, it indicates that pattern No. 4 should execute twice in addition. Include origin one time execution, total execute three times.

Actual Step Parameter: Execution step number per pattern (can set to 0 ~ 7). For example, when set `PStP7` to 2, it indicates that pattern No 7 will not execute other steps than step 0 to step2.

Execution: When `r-s` is set to `run`, the program will start to execute in order from the step 0 of start pattern.

When `r-s` is set to `Stop`, the program will stop and the control output is disabled.

When `r-s` is set to `PStP`, the program will stop and the temperature at that time will be controlled at the set point before program stop. Select `run` again, then the program will restart and execute from step 0 of start pattern.

When `r-s` is set to `PHod`, the program will hold and the temperature at that time will be controlled at the set point before program hold. Select `run` again, then the program will follow the step before hold and start to execute through the rest of the time.

Retransmission Output:

When the 1st group output of this controller is linear voltage or current output, it can be Retransmission that is the output variation corresponding with input. For example, when read

value=0 with input range 0~1000, output will be 0mA or 0V. When read value=1000, output will be 20mA or 10V.

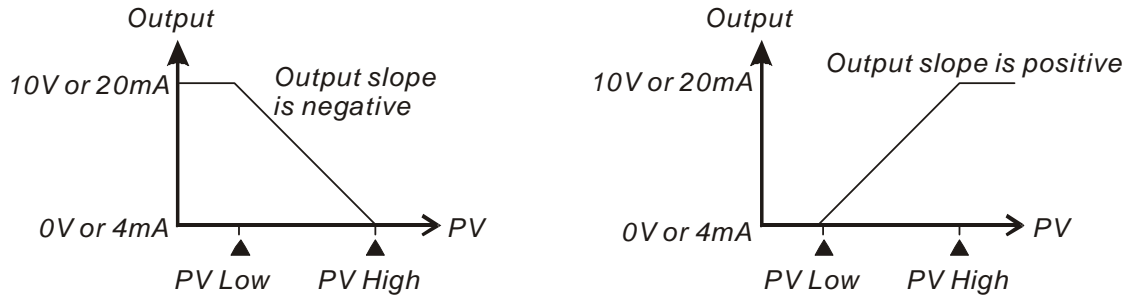

Figure 7: Retransmission

Alarm Output:

This controller provides twelve types of alarm input selections. When PV is higher or lower than SV, alarm output will act. Following table consists of twelve alarm output modes.

SV	Alarm Type	Alarm Output Function
0	No Alarm Function	Output is OFF
1	Deviation upper- and lower-limit: This alarm output operates when PV value is higher than the setting value SV+(AL-H) or lower than the setting value SV-(AL-L).	ON OFF AL-L SV AL-H
2	Deviation upper-limit: This alarm output operates when PV value is higher than the setting value SV+(AL-H).	ON OFF SV AL-H
3	Deviation lower-limit: This alarm output operates when PV value is lower than the setting value SV-(AL-L).	ON OFF AL-L SV
4	Reverse deviation upper- and lower-limit: This alarm output operates when PV value is in the range of the setting value SV+(AL-H) and the setting value SV-(AL-L).	ON OFF AL-L SV AL-H
5	Absolute value upper- and lower-limit: This alarm output operates when PV value is higher than the setting value AL-H or lower than the setting value AL-L.	ON OFF AL-L AL-H
6	Absolute value upper-limit: This alarm output operates when PV value is higher than the setting value AL-H.	ON OFF AL-H
7	Absolute value lower-limit: This alarm output operates when PV value is lower than the setting value AL-L.	ON OFF AL-L
8	Deviation upper- and lower-limit with standby sequence: This alarm output operates when PV value reaches set point (SV value) and the value is higher than the setting value SV+(AL-H) or lower than the setting value SV-(AL-L).	ON OFF AL-L SV AL-H
9	Deviation upper-limit with standby sequence: This alarm output operates when PV value reaches set point (SV value) and the reached value is higher than the setting value SV+(AL-H).	ON OFF SV AL-H
10	Deviation lower-limit with standby sequence: This alarm output operates when PV value reaches the set point (SV value) and the reached value is lower than the setting value SV-(AL-L).	ON OFF AL-L SV
11	Hysteresis upper-limit alarm output: This alarm output operates if PV value is higher than the setting value SV+(AL-H). This alarm output is OFF when PV	ON OFF AL-L AL-H

SV	Alarm Type	Alarm Output Function
	value is lower than the setting value SV+(AL-L).	
12	Hysteresis lower-limit alarm output: This alarm output operates if PV value is lower than the setting value SV-(AL-H). This alarm output is OFF when PV value is higher than the setting value SV-(AL-L).	

Attention: AL-H and AL-L include AL1H, AL2H and AL1L, AL2L. When the 1st group output is set to alarm output, AL1H (1024H) and AL1L (1025H) will be used. When the 2nd group output is set to alarm output, AL2H (1026H) and AL2L (1027H) will be used.

7 LED DISPLAY

1. When power is normal, POWER LED will be lit.
2. LED will be lit after power on. Within one second after power on, communication protocol will be displayed; and at the following second after communication protocol displayed, communication address will be displayed. After that, LED will all be lit to show operation is normal.
3. When control action is executing, RUN LED will be lit.
4. When input, memory, or communication happens to error, ERROR LED will be lit.
5. When output is acted, the corresponding LED will be lit.
6. When PID program is auto adjusting parameter, AT LED will blink.
7. RX LED will blink when receiving communication signal and TX LED will blink when transmitting communication signal.

Protocol Format of LED Display When Power On

AT	TX	RX	O1	O2	Err	Run
000:2400bps	001:4800bps	010:9600bps	Parity 00:None	01:Even	0: ASCII	0:2 Stop bit
011:19200bps	100:38400bps		10: Odd		1: RTU	1:1 Stop bit

Communication address display: AT (bit 6) and Run (bit 0) will combine to binary code.

8 PASSWORD FUNCTION

The default of password will not operate. After writing 4-byte password into specific communication address, password function will be activated. There are three levels for password protection:

1. Level1: only LED status, settings, and input values can be read via communication. It is unable to revise anything.
2. Level2: only LED status, settings, and input value can be read via communication. Also, it is able to revise setting.
3. Level3: all the settings can be read via communication, but it is only revisable for settings and AT adjustment.
4. No password function.

Once password is set (106EH~1070H), the controller will enter level 1. For entering another level, please key in corresponding password in 106BH~106DH (see Address and content of Data Register). After power off, it will get back to level one. If password protection function shall be dismissed, it is necessary to clear all password setting.

To enable password function, it is necessary to write corresponding password (106EH~1070H) when password status is dismissed. To dismiss password levels, intended password setting should be write in specific function address 106EH~1070H.

Password status can be read from 106EH~1070H. Statuses corresponding to each bit are shown as the following table:

Bit	b0	b1	b2	b3	b4	b5	b6
Status	Level 1	Level 2	Level 3	Level 1 locked	Level 2 locked	Level 3 locked	Unlock

Bit=0 means no password setting. Bit=1 means password is set (b0~b2). b3~b6 are used for displaying current password status.

9 SYNCHRONOUS COMMUNICATION PROTOCOL & AUTO NUMBER ID FUNCTION

By using Auto Number ID function, the communication protocol of DTC2000 can be set the same as the one of DTC1000. ID numbers tend to increase.

1. Set the auto communication flag to be "1" for DTC1000 (communication address 1022H).
2. Switch off the controller before connecting to another DTC2000. After that, switch on the power again.
3. Communication default: 9600bps, 7bits, Even, 1 stop bit.
4. This function will result in additional 3~5 seconds for power on.

10 RS-485 COMMUNICATION

1. Supporting transmission speed: 2400, 4800, 9600, 19200, 38400bps.
2. Non-supported formats: 7, N, 1 or 8, E, 2 or 8, O, 2.
3. Communication protocol: Modbus (ASCII or RTU)
4. Function code: 03H to read the content of register (max. 8 words). 06H to write one word into register. 01H to read bits data (max. 16 bits). 05H to write one bit to register.
5. Address and Content of Data Register:

Address	Setting	Content	Explanation
1000H		Process value (PV)	Temperature unit: 0.1 degree. Analog input: 1EU. Following read values happen to errors: 8002H : Initial process (Temperature value is not got yet) 8003H : Temperature sensor is not connected 8004H : Temperature sensor input error 8006H : Cannot get temperature value, ADC input error 8007H : Memory read/write error
1001H	0	Set point (SV)	Unit: 0.1 degree. Analog input: 1EU.
1002H	6000	Upper-limit of temperature range	Upper-limit ban, unit: 0.1 degree.
1003H	-200	Lower-limit of temperature range	Lower-limit ban, unit: 0.1 degree.
1004H	12	Input temperature sensor type	Please refer to the contents of the "Temperature Sensor Type and Temperature Range" for detail
1005H	0	Control method	0: PID, 1:ON/OFF, 2: manual tuning, 3:PID program control
1007H	4	1st group of Heating/Cooling control cycle	0~99, 0:0.5 sec
1008H	4	2nd group of Heating/Cooling control cycle	0~99, 0:0.5 sec (it will be invalid when both groups are control output at the same time)
1009H	476	PB Proportional band	1 ~ 9999, unit: 0.1 degree, analog input: 1EU
100AH	260	Ti Integral time	0~9999
100BH	41	Td Derivative time	0~9999
100CH	0	Integration default	0~1000, unit: 0.1%
100DH	0	Proportional control offset error value, when Ti = 0	0~1000, unit: 0.1%
100EH	100	COEF setting when	1 ~ 9999, unit: 0.01

Address	Setting	Content	Explanation
		Dual Loop output control are used	
100FH	0	Dead band setting when Dual Loop output control are used	-999~9999, unit: 0.1 degree or 1EU
1010H	0	Hysteresis setting value of the 1st output group	0~9999, unit: 0.1 degree or 1EU
1011H	0	Hysteresis setting value of the 2nd output group	0~9999, unit: 0.1 degree or 1EU
1012H	0	Output value read and write of Output 1	Unit: 0.1%, write is valid only under manual control mode
1013H	0	Output value read and write of Output 2	Unit: 0.1%, write is valid only under manual control mode
1014H	0	Upper-limit regulation of analog linear output	1 scale=2.8 μ A=1.3mV
1015H	0	Lower-limit regulation of analog linear output	1 scale=2.8 μ A=1.3mV
1016H	0	Temperature regulation value	-999~+999, unit: 0.1 degree or 1EU
1020H	0	Alarm 1 type	Please see the contents of the "Alarm Outputs" for detail
1021H	0	Alarm 2 type	Please see the contents of the "Alarm Outputs" for detail
1022H	0	Auto-setting communication flag	Auto setting ban of communication: 0, auto setting of communication: 1
1024H	40	Upper-limit alarm 1 AL1H	Please see the contents of the "Alarm Outputs" for detail
1025H	40	Lower-limit alarm 1 AL1L	Please see the contents of the "Alarm Outputs" for detail
1026H	40	Upper-limit alarm 2 AL2H	Please see the contents of the "Alarm Outputs" for detail
1027H	40	Lower-limit alarm 2 AL2L	Please see the contents of the "Alarm Outputs" for detail
102AH		Read/Write status	b1:ALM2, b2:°C, b3:°F, b4: ALM1, b5: O2, b6:O1, b7: AT
102CH	0	Setting of positive/negative proportional output	0: positive, 1: negative
102EH		LED status	b0: RUN,b1: ERR, b2: O2,b3: O1,b4: RX,b5:TX b6: AT
102FH		Software version	V1.00 indicates 0x100
1030H	0	Start pattern number	0~7
1032H		Remaining time of read execution	Unit: second
1033H		Remaining time of reading execution step	Unit: minute
1034H		Step number of reading current execution step	0~7

Address	Setting	Content	Explanation
1035H		Executing number of reading current pattern	0~7
1037H	1000	Upper-limit of proportional output	0~100% max. analog output is upper limit, unit: 0.1%
1038H	0	Lower-limit of proportional output	0~100% max. analog output is lower limit, unit: 0.1%
1040H~1043H	7	Actual step number setting inside the correspond pattern	0~7 = N means the pattern is executed from step from 0 to N.
1050H~1053H	0	Cycle number of repeating executing pattern 0~7	0~199 means the pattern is executed for 1~200 times.
1060H~1063H	0	Link pattern number setting of the current pattern	0~8, 8 means program end. 0~7 means the next execution number after completing current pattern.
1068H	1	Control execution/Stop setting	0: Stop, 1: execute, 2: program end, 3: program hold
1069H	0	Output 1: control selection	0: heating, 1: cooling, 2: alarming, 3: proportional output
106AH	0	Output2: control selection	0: heating, 1: cooling, 2: alarming
106BH	0	Dismiss level 1 Read/write allowed	Shall be same as level 1 password setting (106E)
106CH	0	Dismiss level 2. Use level 3.	Shall be same as level 2 password setting (106F)
106DH	0	Dismiss level 3. Use level 2	Shall be same as level 3 password setting (1070)
106EH	0	Dismiss level 1/Set password	Clear old password before new password setting
106FH	0	Dismiss level 2/Set password	Clear old password before new password setting
1070H	0	Dismiss level 3/Set password	Clear old password before new password setting
1071H	1	Read/Write communication address	1~247
1072H	0	Read/Write communication format	RTU:1, ASCII:0
1073H	2	Baud rate setting of communication	0~4: 2400~38400
1074H	1	Data length setting of communication	0: 8bit 1: 7bit
1075H	1	Parity bit setting	0: None 1:Even 2: Odd
1076H	1	Stop bit setting	0: 2 stop bit 1: 1stop bit
2000H~203FH	0	Pattern 0~7 to set target temperature Pattern 0: 2000H~2007H	Temperature measure unit: 0.1 degree
2080H~20BFH	0	Pattern 0~7 to set execution time. Pattern 0: 2080H~2087H	Time 0~900 (1 minute for each scale)

6. Address and Content of Bit Register: (First bit of reading will put into LSB, Write data = FF00H for bit set, 0000H for bit data as "0")

0811H	Temperature unit display selection	0: °F, 1: °C (default)
0813H	AT setting	AT setting OFF: 0 (default), AT setting ON: 1
0814H	Control RUN/STOP setting	0: STOP, 1: Execute (default)
0815H	Program hold flag	1: Program temporary stop
0816H	Program stop flag	1: Program stop

7. Communication format:01: read bit data, 05: write bit data, 03: read word, 06: write word.

ASCII Mode:

To Read Instruction			To Read Response Message			To Write Instruction			To Write Response Message			
Starting word	' :	' :	Starting word	' :	' :	Starting word	' :	' :	Starting word	' :	' :	
Machine address 1	'0'	'0'	Machine address 1	'0'	'0'	Machine address 1	'0'	'0'	Machine address 1	'0'	'0'	
Machine address 0	'1'	'1'	Machine address 0	'1'	'1'	Machine address 0	'1'	'1'	Machine address 0	'1'	'1'	
Instruction 1	'0'	'0'	Instruction 1	'0'	'0'	Instruction 1	'0'	'0'	Instruction 1	'0'	'0'	
Instruction 0	'3'	'1'	Instruction 0	'3'	'1'	Instruction 0	'6'	'5'	Instruction 0	'6'	'5'	
To read data/Staring word address	'1'	'0'	Response data length (byte)	'0'	'0'	To write data address	'1'	'0'	To write data address	'1'	'0'	
	'0'	'8'		'4'	'2'		'0'	'8'		'0'	'8'	
	'0'	'1'		'0'	'1'		'0'	'1'		'0'	'0'	'1'
	'0'	'0'		'1'	'7'		'1'	'0'		'1'	'0'	'1'
To read data length/Word length (word/bit)	'0'	'0'	Data content of 1000H/081xH	'F'	'0'	To write data content	'0'	'F'	To write data content	'0'	'F'	
	'0'	'0'		'4'	'1'		'3'	'F'		'3'	'F'	
	'0'	'0'		'0'			'E'	'0'		'E'	'0'	
	'2'	'9'		'0'			'8'	'0'		'8'	'0'	
LRC1 check	'E'	'D'	Data content of 1001H	'0'		LRC1	'F'	'E'	LRC1	'F'	'E'	
LRC 0 check	'A'	'D'		'0'		LRC 0	'D'	'3'	LRC 0	'D'	'3'	
Ending word 1	CR	CR	LRC1 check	'0'	'E'	Ending word 1	CR	CR	Ending word 1	CR	CR	
Ending word 0	LF	LF	LRC 0 check	'3'	'4'	Ending word 0	LF	LF	Ending word 0	LF	LF	
			Ending word 1	CR	CR							
			Ending word 0	LF	LF							

LRC Check:

LRC check is the added sum from "Machine Address" to "Data content". For example, 01H + 03H + 10H + 00H + 00H + 02H = 16H, then take the complementary of 2 to get EA.

RTU Mode:

To Read Instruction			To Read Response Message			To Write Instruction			To Write Response Message		
Machine address	01H	01H	Machine address	01H	01H	Machine address	01H	01H	Machine address	01H	01H
Instruction	03H	02H	Instruction	03H	02H	Instruction	06H	05H	Instruction	06H	05H
Starting address of reading data	10H	08H	Response data length (byte)	04H	02H	To write data address	10H	08H	To write data address	10H	08H
	00H	10H					01H	10H		01H	10H
To read data length (word/bit)	00H	00H	Data content 1	01H	17H	To write data content	03H	FFH	To write data content	03H	FFH
	02H	09H		F4H	01H		20H	00H		20H	00H
CRC low byte	C0H	BBH	Data content 2	03H		CRC low byte	DDH	8FH	CRC low byte	DDH	8FH
CRC high byte	CBH	A9H		20H		CRC high byte	E2H	9FH	CRC high byte	E2H	9FH
			CRC low byte	BBH	77H						
			CRC high byte	15H	88H						

Following is a CRC (Cyclical Redundancy Check) program example:

```

unsigned int reg_crc = 0xffff; i = 0;
while (length--)
{
  reg_crc ^= RTUData[i];
  i ++;
  for (j = 0; j < 8; j++)
  {
    if (reg_crc & 0x01) reg_crc = (reg_crc >> 1) ^ 0xA001;
    else
      reg_crc = reg_crc >> 1;
  }
}
return(reg_crc);

```

11

INSTALLATION

DTC modules can be expanded up to 8, and installed with DIN rail mounting

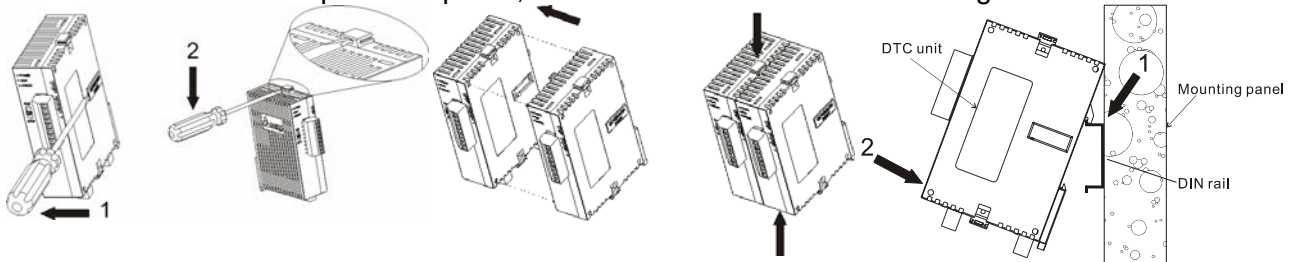

Delta Electronics, Inc. 31-1 Shien Pan Road, Kuei San Industrial Park, Taoyuan Shien 33341, Taiwan, R.O.C.
 TEL: 886-3-362-6301 FAX: 886-3-362-7267