



Low voltage AC drives

ABB industrial drives ACS880, drive modules 0.55 to 3200 kW Catalog



ACS880 series drives Uncompromised productivity

Contents

4	Simplifying your world without limiting your possibilities
6	What does all-compatible mean for you?
8	Cost and time savings with drive-based functional safety
9	Drive-based application programming
10	Save time, ease troubleshooting and improve drive performance with ABB smartphone apps
12	Technical data and how to select a drive
13	Single drive modules, ACS880-01 with option +P940 or +P944
14–15	Ratings, types and voltages, ACS880-01
16	Single drive modules, ACS880-04 and ACS880-04F
17	High power single drive module packages, ACS880-04
18	Ratings, types and voltages, ACS880-04, -04 / -04F, -04XT
19	Ratings, types and voltages, ACS880-04 nxR8i
20	Regenerative single drive module packages, ACS880-14
21	Ratings, types and voltages, ACS880-14
22	Ultra-low harmonic single drive module packages, ACS880-34
23	Ratings, types and voltages, ACS880-34
24–25	Multidrive modules, ACS880-X04
26–31	Ratings, types and voltages, inverter modules and supply units
32	Standard interface and extensions for comprehensive connectivity
33	Standard software for scalable control and functionality
34–35	Application control programs
36	Designed to control virtually any type of AC motor
37	Intuitive human-machine interface
37	PC tool for easy startup and maintenance
38	Integrated safety simplifies configuration
39	Drive application programming based on IEC standard 61131-3
40	Flexible connectivity to automation networks
41	Input/output extension modules for increased connectivity
41	Speed feedback interfaces for precise process control
41	I/O option extension adapter
41	DDCS communication option modules
41	Remote monitoring access worldwide
42	EMC – electromagnetic compatibility
43–45	Sine filters
46–49	Brake options
50	ACS880-604 3-phase dynamic brake units
51	DC-DC converter
53–54	du/dt filters
55	Dimensioning tool for selecting the optimal drive
56–59	Summary of features and options
60–61	Drive services



When your electric motor-driven application requires dependable capability and scalability to meet your exact requirements for variable speed operation, you need our ACS880 industrial drives. Our drives are built to truly understand and refine your business and cover every possible application. We make your opportunities work with our strong drives series that covers all your process control needs no matter what your industry. These are our ACS880 industrial drives, our benchmark of uncompromising productivity, serving you locally on a global scale.

Simplifying your world without limiting your possibilities

Drive modules

The all-compatible drives are designed to provide customers across industries and applications with unprecedented levels of compatibility and flexibility. The ACS880 drive modules are customized to meet the precise needs of industries such as metals, oil and gas, mining, marine, material handling, pulp and paper. They control a wide range of applications such as cranes, conveyors, pumps and fans.

Direct torque control (DTC)

ABB's signature motor control technology provides precise speed and torque control for all applications and virtually any type of AC motor.

[See page 33](#)

Application control programs

A range of ready-made programs to optimize productivity and usability in applications such as cranes, winches and artificial lifting.

[See page 34](#)

Removable memory unit

Stores all the software and parameter configurations in an easily replaceable and simple-to-install module.

[See page 33](#)



Energy efficiency

The drive provides features such as an energy optimizer and energy efficiency information that help you monitor and save the energy used in the processes.

[See page 33](#)

Remote monitoring

With a built-in Web server, NETA-21 makes worldwide access easy for industry applications.

[See page 41](#)



Robust, long lifetime design

The ACS880 is designed to last for a long time, even in harsh conditions. The benefits for you include a nine-year service interval and good tolerance to vibration and contamination.



Wide range of safety features

Safe torque off is built-in as standard. An optional safety functions module provides extended safety functions, simplifying the configuration and reducing installation space.

[See page 38](#)



Drive application programming

Customizable to meet the precise application needs based on IEC 61131-3. Uses the same programming environment and is also easy to integrate with other ABB components such as PLCs and HMIs.

[See page 39](#)



Drives going mobile

We offer several smartphone applications to ease and enhance the use of ABB drives. These tools provide a user-friendly and easy-to-use approach for the commissioning, servicing and use of ABB drives.

[See page 10](#)

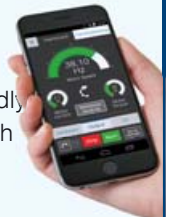

Intuitive human-machine interface

Intuitive, high-contrast and high-resolution display enabling easy navigation in multiple languages.

[See page 37](#)

Startup and maintenance tool

Drive composer PC tool for drive startup, configuration and daily use and process tuning. PC tool is connected to the drive via Ethernet or USB interface.

[See page 37](#)

Communication with all major automation networks

Fieldbus adapters enable connectivity with all major automation networks.

[See page 40](#)



Flexible product configurations

Drives are built to order with a wide range of options such as braking options and different enclosure variants.

[See product variant pages](#)

Extended connectivity

In addition to the standard interfaces, the drive has three built-in slots for additional input/output extension modules and speed feedback interfaces.

[See page 41](#)



What does all-compatible mean for you?

Business all-compatible

The all-compatible drives are not just equipment – they are part of your business strategy. Providing better control over your processes, our drives mean lower energy consumption, improved productivity, flexibility and ease of use. In addition to drives, we offer a wide range of products and services to support your business. With offices in over 90 countries and a global technical partner network, we are in a good position to offer technical advice and local support, worldwide.

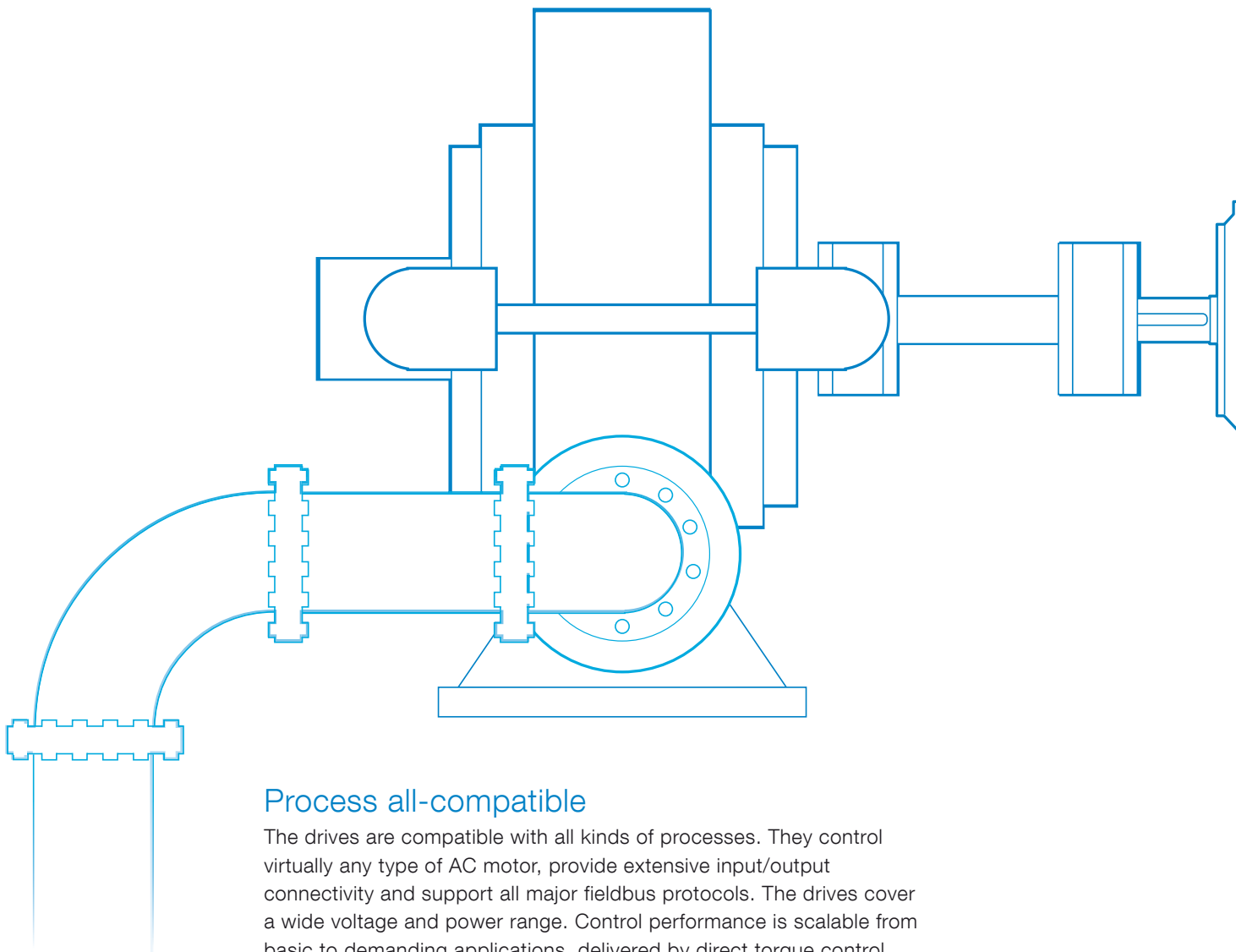

Process all-compatible

The drives are compatible with all kinds of processes. They control virtually any type of AC motor, provide extensive input/output connectivity and support all major fieldbus protocols. The drives cover a wide voltage and power range. Control performance is scalable from basic to demanding applications, delivered by direct torque control (DTC). The flexibility and scalability of the drives enable one drive platform to control virtually any application or process, making your drive selection easy.

Environment all-compatible

There is increased demand for industries to reduce their impact on the environment. Our drives can help you reduce energy consumption in a wide range of applications. Our drives have an energy optimizer feature that ensures maximum torque per ampere, reducing energy drawn from the supply. The built-in energy efficiency calculators help you to analyze and optimize your processes. We can help you to investigate the energy-saving potential of selected applications with our six-step energy appraisal.

Our wall-mounted ACS880 industrial drives fulfill the highest IE2 drive (EN 50598-2) energy efficiency class, further reducing environmental impact. In addition, all ACS880 industrial drives are compatible with high-efficiency IE4 motors.

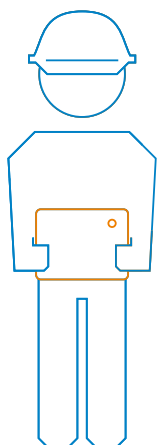
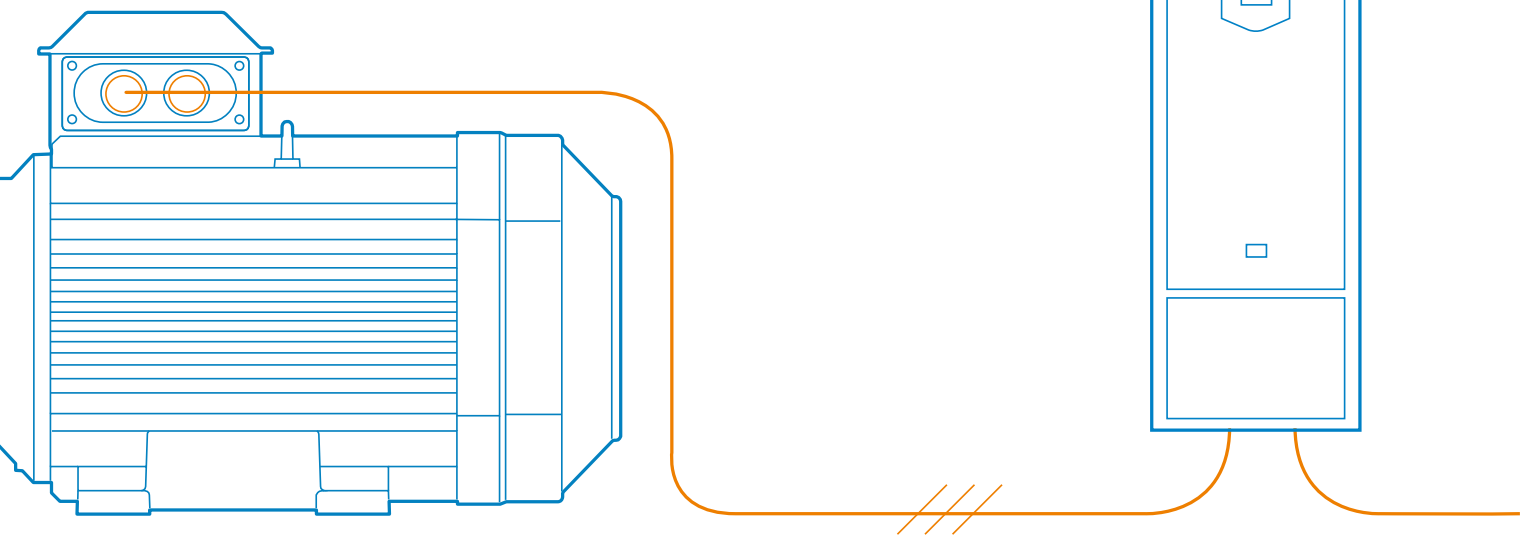

Human all-compatible

All our drives share easy-to-use interfaces, saving you time during drive commissioning and maintenance. When you have learned it once, you can use it with all the drives in our all-compatible drives portfolio.

The control panel supports over 20 languages. With the PC tool, you get extensive drive monitoring capabilities and quick access to the drive settings. Integrated and certified safety features provide safety for machine operators.

To further improve the user experience, we have developed mobile apps that can be utilized in interacting with the drive. These apps give you an easy graphical interface for management, maintenance and service of your drives.

Cost and time savings with drive-based functional safety

With our ACS880 drive, you can achieve SIL 3/PL e safety level with certified safety functions modules. The safety module is easy to integrate inside the drive and offers you several safety functions. Integration with automation systems is quick and reliable using PROFI-safe connectivity. ACS880 drives have a safe torque off (STO) function as a standard.

Scalable safety with PROFI-safe and Safety PLC

The safety functionality can be scaled to your needs. From a safety module integrated into a single relay to a complete safety system with a PROFI-safe and a safety PLC, eg, AC500-S.

Safely limited speed without encoders

The SIL 3/PL e certified safely-limited speed (SLS) function prevents the motor from exceeding a defined speed limit with no encoders. This allows machine interaction to be performed at a safe speed without stopping the process.

TÜV-certified safety design tool

Functional safety design tool (FSDT-01) is used for machinery safety. It helps to increase the safety of users in the vicinity of machines. You can perform functional safety modeling, design, calculations and verification for machine functional safety.



Drive-based application programming

The built in PLC capability of the ACS880 provides you a possibility to customize the drive for your application without the cost of extra hardware. As programming is based on the IEC 61131-3 standard used in AC500 PLCs and by many other PLC vendors, you do not need to retrain your staff. By decentralizing your machine control closer to the process, you achieve better control performance.

Adaptive programming

Adaptive programming is ideal for creating simple control programs for various applications. It does not require expertise in programming and is offered as a standard in All-compatible drives.

Application programming

Application programming makes it possible for system integrators and machine builders to integrate their desired functionality and know-how directly into the drive. It utilizes standard IEC 61131-3 programming used by many PLCs like the AC500. This means that programs can be easily moved from the drive to a PLC and extended into a larger system.

Automation builder

Automation Builder is a software suite for automation engineering, which makes programming industry devices such as drives, PLCs, robots and human-machine interfaces (HMIs) easy using one integrated engineering suite. Automation builder is used both for engineering devices and entire automation projects.

Save time, ease troubleshooting and improve drive performance with ABB smartphone apps

Better connectivity and user experience with Drivetune

Easy and fast access to product information and support



Manage your drives and the process lines and machines they control

Easy access to cloud-based drive and process information from anywhere via an online connection



Start up, commission and tune your drive and application



Simplified user guidance with instant access to drive status and configuration



Performance optimization via drive troubleshooting features and fast support



Services and support on the go with Drivebase

Search for support documents and contacts



Maintain and service all your installed drives on one or multiple sites

Get 6 months extra warranty for free by registering your drive with the Drivebase app

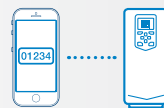

Access your product and service information in the cloud from anywhere



Access your drive's diagnostics data



Push notifications for critical product and service updates



Access information anywhere

Download the apps using the QR codes below or directly from the app stores

Drivetune for commissioning and managing drives

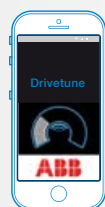

Drivebase for ensured reliability and reduced downtime on production sites

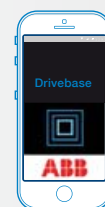



Technical data and how to select a drive

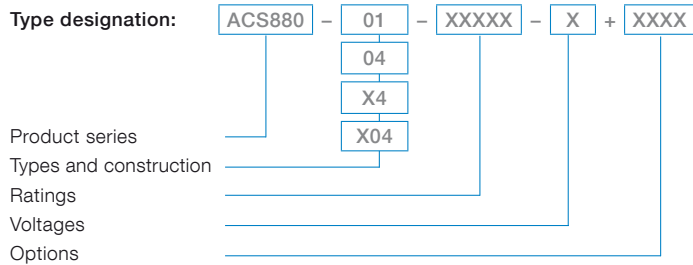

To choose the right drive for your application, please refer to the rating tables on pages 12, 13, 16, 17, 19, 21, 24, 25, 26, 27, 28 and 29 or use ABB's DriveSize (page 48) dimensioning tool. The selected drive has a unique type designation, which identifies the drive by construction, power and voltage range. The options are added to the type designation with a "plus" code. Build up your own ordering code using the type designation key or contact your local ABB drives sales office and let them know your needs/requirements.

Mains connection	
Voltage and power range	3-phase, $U_{N2} = 208$ to 240 V, +10/-15% (-01) 3-phase, $U_{N3} = 380$ to 415 V, +10/-15% (-01, -04) 3-phase, $U_{N5} = 380$ to 500 V, +10/-15% (-01, -04) 3-phase, $U_{N7} = 525$ to 690 V, +10/-15% (-01, -04) 3-phase, $U_{N3} = 380$ to 415 V, $\pm 10\%$ (-x04, -04 ³⁾ , -x4 ³⁾ 3-phase, $U_{N5} = 380$ to 500 V, $\pm 10\%$ (-x04, -04 ³⁾ , -x4 ³⁾ 3-phase, $U_{N7} = 525$ to 690 V, $\pm 10\%$ (-x04, -04 ³⁾ , -x4 ³⁾ 0.55 to 3200 kW Diode supply unit (DSU) 55 to 5445 kVA IGBT supply unit (ISU) 5.5 to 3679 kVA Regenerative rectifier unit (RRU) 400 to 4135 kVA
Frequency	50/60 Hz $\pm 5\%$
Power factor	IGBT supply module (ISU): $\cos\phi = 1$ (fundamental) $\cos\phi = 0.99$ (total) Diode supply module (DSU) and Regenerative rectifier unit (RRU): $\cos\phi = 0.98$ (fundamental) $\cos\phi = 0.93$ to 0.95 (total)
Efficiency (at nominal power)	98% with DSU and RRU 97% with ISU
Motor connection	
Voltage	3-phase output voltage 0 to $U_{N2}/U_{N3}/U_{N5}/U_{N7}$
Frequency	0 to ± 500 Hz ¹⁾⁴⁾
Motor control	Direct torque control (DTC)
Torque control:	Torque step rise time: Open loop <5 ms with nominal torque Closed loop <5 ms with nominal torque Non-linearity: Open loop $\pm 4\%$ with nominal torque Closed loop $\pm 3\%$ with nominal torque loop
Speed control:	Static accuracy: Open loop 10% of motor slip Closed loop 0.01% of nominal speed Dynamic accuracy: Open loop 0.3 to 0.4% seconds with 100% torque step Closed loop 0.1 to 0.2% seconds with 100% torque step
Product compliance	
<ul style="list-style-type: none"> - CE - Low Voltage Directive 2014/35/EU - Machinery Directive 2006/42/EC - EMC Directive 2014/30/EU - ATEX Directive 2014/43/EU - Quality assurance system ISO 9001 and Environmental system ISO 14001 - RoHS - UL, cUL, UL508C and CSA, C22.2 NO.14-10, EAC/GOST R ⁵⁾, RCM - Functional safety: STO, TÜV Nord certificate - ATEX-certified Safe Disconnection Function, Ex II (2) GD 	
EMC according to EN 61800-3 (2004)	
Category C2 with internal option (-01)	
1 st environment category C2 included as option (-x4 ³⁾)	
2 nd environment category C3 included as standard (-x04, -x4 ³⁾)	
2 nd environment category C3 included as option (-01, -04)	
2 nd environment category C4 included as standard	

Environmental limits	
Ambient temperature	Transport -40 to +70 °C Storage -40 to +70 °C Operation (air-cooled) -15 to +40 °C as standard (-01, -04) 0 to +40 °C as standard (-x04, -04 ³⁾ , -x4 ³⁾ +40 to +55 °C with derating of 1%/1 °C (-04 /-01 ⁴⁾) +40 to +50 °C with derating of 1%/1 °C (-x04, -04 ³⁾)
Cooling method	Air-cooled Dry clean air
Altitude	0 to 1,000 m Without derating 1,000 to 4,000 m With derating 1%/100 m ⁷⁾
Relative humidity	5 to 95%, no condensation allowed
Degree of protection	IP00 (-04 ³⁾ , -x4 ³⁾ , -x04) IP20 (-01, -04)
Paint color	RAL 9017, RAL 9002
Contamination levels	No conductive dust allowed
Storage	IEC 60721-3-1, Class 1C2 (chemical gases), Class 1S2 (solid particles)
Transportation	IEC 60721-3-2, Class 2C2 or 3C2 (chemical gases), Class 2S2 (solid particles without air inlet filters)
Operation	IEC 60721-3-3, Class 3C2 (chemical gases), Class 3S2 (solid particles)
Functional safety	Standard Safe torque off (STO according EN/IEC 61800-5-2) IEC 61508 ed2: SIL 3, IEC 61511: SIL 3, EN/IEC 62061: SIL CL 3, EN ISO 13849-1: PL e
Internal safety option, the Safety functions module	Safe stop 1 (SS1), safely-limited speed (SLS), safe stop emergency (SSE), safe brake control, (SBC) and safe maximum speed (SMS), prevention of unexpected startup (POUS), Safe direction (SDI), Safe speed monitor (SSM) EN/IEC 61800-5-2, IEC 61508 ed2: SIL 3, IEC 61511: SIL 3, EN/IEC 62061: SIL CL 3, EN ISO 13849-1: PL e TÜV Nord certified ⁶⁾

C = Chemically active substances

S = Mechanically active substances

¹⁾ For higher operational output frequencies please contact your local ABB office

²⁾ Please check availability per drive type

³⁾ Single drive module packages (see page 17 for more information)

⁴⁾ Operation above 120 Hz might require type specific derating, please contact your local ABB office

⁵⁾ EAC has replaced GOST R

⁶⁾ Pending (except for -01 and -04 single drive modules)

⁷⁾ Derating reduced by lower than 40 °C ambient temperature

Single drive modules, ACS880-01 with option +P940 or +P944

Our all-compatible ACS880-01 single drives support easy and cost efficient cabinet installation with option +P940 or +P944. The optimized module design makes cabinet installation easy and minimizes the need for cabinet space, while providing all-compatible features in one compact drive module. The power range is from 0.55 to 250 kW and the voltage range is from 230 to 690 V. The enclosure class is IP20 as standard.

These single drive modules are customized to the precise needs of industries such as oil and gas, mining, metals, chemicals, cement, power plants, material handling, pulp and paper, sawmills and marine. They are designed to control a wide range of applications including cranes, extruders, winches, winders, conveyors, mixers, compressors, pumps and fans.

Optimized for cabinet assembly

All our modules (frame sizes R1 to R9) are built-on ABB's common drives architecture for easy commissioning and use. At the heart of the drive is direct torque control (DTC), ABB's premier motor control technology. To optimize the use of cabinet space, the ACS880-01 modules can be mounted side by side inside the cabinet. Because the drive module has built-in EMC filter, choke and braking chopper, design effort is reduced and installation is made easy. The extensive range of built-in and external options include EMC filters, encoders, resolvers, du/dt filters, sine filters, chokes and brake resistors, as well as application-specific software. Built-in safety features, such as safe torque off (STO), reduce the need for external safety components. Multiple drives can be daisy-chained for synchronized drive-to-drive communication. With the panelbus feature, several drive modules inside a cabinet can be accessed and operated using one common control panel. Our offering also covers an option for flange mounting with IP55 back side protection. In flange mounting the control electronics are separated from the cooling airflow for better thermal management.

ABB provides an extensive selection of support documentation for planning including dimension drawings in different formats, EPLAN P8 macros and line apparatus selection tool for selecting external components on the line side and motor side of the drive.

Main features

- Optimized for easy and cost efficient cabinet installation
- Enclosure class IP20
- Compact design for easy installation, commissioning and maintenance
- Side-by-side mounting
- Built-in EMC filter (as option), choke (as standard) and braking chopper (as option for frame sizes R5 to R9) will reduce design effort and makes installation easy
- Direct torque control (DTC) as standard, for high performance motor control
- Integrated safety including safe torque off (STO) as standard and the optional safety functions module, FSO-12 (TÜV Nord certified)
- Supports various motor types including synchronous reluctance motors
- Intuitive control panel with USB connection
- Removable memory unit for easy maintenance
- Drive composer PC tool for commissioning and configuration
- Primary control program - common software used throughout the ACS880 drive series
- Control unit supporting a wide range of fieldbuses, feedback devices and input/output options
- Coated boards as standard
- Controllable cooling fan
- Incoming air temperature measurement for protecting the drive from different temperature related failure mechanisms
- du/dt and sine filter option for motor protection



Flange mounted ACS880-01, frame size R8, IP20



ACS880-01, frame sizes R1, R8 and R5, IP20

Ratings, types and voltages Wall-mounted drives, ACS880-01

$U_N = 230\text{ V}$ (range 208 to 240 V). The power ratings are valid at nominal voltage 230 V (0.55 to 75 kW).

Nominal ratings			Light-overload use		Heavy-duty use		Noise level	Heat dissipation	Air flow	Type designation	Frame size
I_N A	I_{max} A	P_N kW	I_{Ld} A	P_{Ld} kW	I_{Hd} A	P_{Hd} kW	dBA	W	m ³ /h		
4.6	6.3	0.75	4.4	0.75	3.7	0.55	46	73	44	ACS880-01-04A6-2	R1
6.6	7.8	1.1	6.3	1.1	4.6	0.75	46	94	44	ACS880-01-06A6-2	R1
7.5	11.2	1.5	7.1	1.5	6.6	1.1	46	122	44	ACS880-01-07A5-2	R1
10.6	12.8	2.2	10.1	2.2	7.5	1.5	46	172	44	ACS880-01-10A6-2	R1
16.8	18.0	4.0	16.0	4.0	10.6	2.2	51	232	88	ACS880-01-16A8-2	R2
24.3	28.6	5.5	23.1	5.5	16.8	4	51	337	88	ACS880-01-24A3-2	R2
31.0	41	7.5	29.3	7.5	24.3	5.5	57	457	134	ACS880-01-031A-2	R3
46	64	11	44	11	38	7.5	62	500	200	ACS880-01-046A-2	R4
61	76	15	58	15	45	11	62	630	200	ACS880-01-061A-2	R4
75	104	18.5	71	18.5	61	15	62	680	280	ACS880-01-075A-2	R5
87	122	22	83	22	72	18.5	62	730	280	ACS880-01-087A-2	R5
115	148	30	109	30	87	22	67	840	435	ACS880-01-115A-2	R6
145	178	37	138	37	105	30	67	940	435	ACS880-01-145A-2	R6
170	247	45	162	45	145	37	67	1260	450	ACS880-01-170A-2	R7
206	287	55	196	55	169	45	67	1500	450	ACS880-01-206A-2	R7
274	362	75	260	75	213	55	65	2100	550	ACS880-01-274A-2	R8

$U_N = 400\text{ V}$ (range 380 to 415 V). The power ratings are valid at nominal voltage 400 V (0.55 to 250 kW).

Nominal ratings			Light-overload use		Heavy-duty use		Noise level	Heat dissipation	Air flow	Type designation	Frame size
I_N A	I_{max} A	P_N kW	I_{Ld} A	P_{Ld} kW	I_{Hd} A	P_{Hd} kW	dBA	W	m ³ /h		
2.4	3.1	0.75	2.3	0.75	1.8	0.55	46	30	44	ACS880-01-02A4-3	R1
3.3	4.1	1.1	3.1	1.1	2.4	0.75	46	40	44	ACS880-01-03A3-3	R1
4.0	5.6	1.5	3.8	1.5	3.3	1.1	46	52	44	ACS880-01-04A0-3	R1
5.6	6.8	2.2	5.3	2.2	4.0	1.5	46	73	44	ACS880-01-05A6-3	R1
8	9.5	3.0	7.6	3.0	5.6	2.2	46	94	44	ACS880-01-07A2-3	R1
10	12.2	4.0	9.5	4.0	8	3	46	122	44	ACS880-01-09A4-3	R1
12.9	16.0	5.5	12.0	5.5	10	4	46	172	44	ACS880-01-12A6-3	R1
17	21	7.5	16	7.5	12.6	5.5	51	232	88	ACS880-01-017A-3	R2
25	29	11	24	11	17	7.5	51	337	88	ACS880-01-025A-3	R2
32	42	15	30	15	25	11	57	457	134	ACS880-01-032A-3	R3
38	54	18.5	36	18.5	32	15	57	562	134	ACS880-01-038A-3	R3
45	64	22	43	22	38	18.5	62	667	200	ACS880-01-045A-3	R4
61	76	30	58	30	45	22	62	907	200	ACS880-01-061A-3	R4
72	104	37	68	37	61	30	62	1117	280	ACS880-01-072A-3	R5
87	122	45	83	45	72	37	62	1120	280	ACS880-01-087A-3	R5
105	148	55	100	55	87	45	67	1295	435	ACS880-01-105A-3	R6
145	178	75	138	75	105	55	67	1440	435	ACS880-01-145A-3	R6
169	247	90	161	90	145	75	67	1940	450	ACS880-01-169A-3	R7
206	287	110	196	110	169	90	67	2310	450	ACS880-01-206A-3	R7
246	350	132	234	132	206	110	65	3300	550	ACS880-01-246A-3	R8
293	418	160	278	160	246 ¹⁾	132	65	3900	550	ACS880-01-293A-3	R8
363	498	200	345	200	293	160	68	4800	1150	ACS880-01-363A-3	R9
430	545	250	400	250	363 ²⁾	200	68	6000	1150	ACS880-01-430A-3	R9
442	545	250	420	250	363 ⁴⁾	200	68	6000	1150	ACS880-01-442A3	R9

Dimensions (with option +P940)

Frame size	Height (mm)	Width (mm)	Depth (mm)	Weight (kg)
R1	370 ³⁾	155	226	5.7
R2	370 ³⁾	155	249	7.2
R3	420 ³⁾	172	256	9.4
R4	490 ³⁾	203	333	16.1
R5	596 ³⁾	203	333	19.3
R6	569	251	357	38.3
R7	600	284	365	47.6
R8	681	300	386	58.6
R9	680	380	413	85.2

Nominal ratings

I_N Rated current available continuously without overloadability at 40 °C.

P_N Typical motor power in no-overload use.

I_{max} Maximum output current. Available for 10 seconds at start, then as long as allowed by drive temperature.

Light-overload use

I_{Ld} Continuous current allowing 110% I_{Ld} for 1 min/5 min at 40 °C.

P_{Ld} Typical motor power in light-overload use.

Heavy-duty use

I_{Hd} Continuous current allowing 150% I_{Hd} for 1 min/5 min at 40 °C.

P_{Hd} Typical motor power in heavy-duty use.

The ratings apply at 40 °C ambient temperature. At higher temperatures (up to 55 °C) the derating is 1%/1 °C.

¹⁾ 130% overload

²⁾ 125% overload

³⁾ Comes with main power clamp

⁴⁾ 135% overload

Ratings, types and voltages Wall-mounted drives, ACS880-01

$U_N = 500 \text{ V}$ (range 380 to 500 V). The power ratings are valid at nominal voltage 500 V (0.55 to 250 kW).

Nominal ratings			Light-overload use		Heavy-duty use		Noise level	Heat dissipation	Air flow	Type designation	Frame size
I_N A	I_{max} A	P_N kW	I_{Ld} A	P_{Ld} kW	I_{Hd} A	P_{Hd} kW	dBA	W	m ³ /h		
2.1	3.1	0.75	2.0	0.75	1.7	0.55	46	30	44	ACS880-01-02A1-5	R1
3.0	4.1	1.1	2.8	1.1	2.1	0.75	46	40	44	ACS880-01-03A0-5	R1
3.4	5.6	1.5	3.2	1.5	3.0	1.1	46	52	44	ACS880-01-03A4-5	R1
4.8	6.8	2.2	4.6	2.2	3.4	1.5	46	73	44	ACS880-01-04A8-5	R1
5.2	9.5	3.0	4.9	3.0	4.8	2.2	46	94	44	ACS880-01-05A2-5	R1
7.6	12.2	4.0	7.2	4.0	5.2	3	46	122	44	ACS880-01-07A6-5	R1
11.0	16.0	5.5	10.4	5.5	7.6	4	46	172	44	ACS880-01-11A0-5	R1
14	21	7.5	13	7.5	11	5.5	51	232	88	ACS880-01-014A-5	R2
21	29	11	19	11	14	7.5	51	337	88	ACS880-01-021A-5	R2
27	42	15	26	15	21	11	57	457	134	ACS880-01-027A-5	R3
34	54	18.5	32	18.5	27	15	57	562	134	ACS880-01-034A-5	R3
40	64	22	38	22	34	19	62	667	200	ACS880-01-040A-5	R4
52	76	30	49	30	40	22	62	907	200	ACS880-01-052A-5	R4
65	104	37	62	37	52	30	62	1117	280	ACS880-01-065A-5	R5
77	122	45	73	45	65	37	62	1120	280	ACS880-01-077A-5	R5
96	148	55	91	55	77	45	67	1295	435	ACS880-01-096A-5	R6
124	178	75	118	75	96	55	67	1440	435	ACS880-01-124A-5	R6
156	247	90	148	90	124	75	67	1940	450	ACS880-01-156A-5	R7
180	287	110	171	110	156	90	67	2310	450	ACS880-01-180A-5	R7
240	350	132	228	132	180	110	65	3300	550	ACS880-01-240A-5	R8
260	418	160	247	160	240 ¹⁾	132	65	3900	550	ACS880-01-260A-5	R8
361	542	200	343	200	302	200	68	4800	1150	ACS880-01-361A-5	R9
414	542	250	393	250	361 ²⁾	200	68	6000	1150	ACS880-01-414A-5	R9
441	545	315	420	250	361 ⁴⁾	200	68	6000	1150	ACS880-01-441A-5	R9

$U_N = 690 \text{ V}$ (range 525 to 690 V). The power ratings are valid at nominal voltage 690 V (4 to 250 kW).

Nominal ratings			Light-overload use		Heavy-duty use		Noise level	Heat dissipation	Air flow	Type designation	Frame size
I_N A	I_{max} A	P_N kW	I_{Ld} A	P_{Ld} kW	I_{Hd} A	P_{Hd} kW	dBA	W	m ³ /h		
7.3	12.2	5.5	6.9	5.5	5.6	4	62	217	280	ACS880-01-07A3-7	R5
9.8	18	7.5	9.3	7.5	7.3	5.5	62	284	280	ACS880-01-09A8-7	R5
14.2	22	11	13.5	11	9.8	7.5	62	399	280	ACS880-01-14A2-7	R5
18	29	15	17	15	14.2	11	62	490	280	ACS880-01-018A-7	R5
22	44	18.5	21	18.5	18	15	62	578	280	ACS880-01-022A-7	R5
26	54	22	25	22	22	18.5	62	660	280	ACS880-01-026A-7	R5
35	64	30	33	30	26	22	62	864	280	ACS880-01-035A-7	R5
42	70	37	40	37	35	30	62	998	280	ACS880-01-042A-7	R5
49	71	45	47	45	42	37	62	1120	280	ACS880-01-049A-7	R5
61	104	55	58	55	49	45	67	1295	435	ACS880-01-061A-7	R6
84	124	75	80	75	61	55	67	1440	435	ACS880-01-084A-7	R6
98	168	90	93	90	84	75	67	1940	450	ACS880-01-098A-7	R7
119	198	110	113	110	98	90	67	2310	450	ACS880-01-119A-7	R7
142	250	132	135	132	119	110	65	3300	550	ACS880-01-142A-7	R8
174	274	160	165	160	142	132	65	3900	550	ACS880-01-174A-7	R8
210	384	200	200	200	174	160	68	4200	1150	ACS880-01-210A-7	R9
271	411	250	257	250	210	200	68	4800	1150	ACS880-01-271A-7	R9

Nominal ratings

I_N Rated current available continuously without overloadability at 40 °C.

P_N Typical motor power in no-overload use.

I_{max} Maximum output current. Available for 10 seconds at start, then as long as allowed by drive temperature.

Light-overload use

I_{Ld} Continuous current allowing 110% I_{Ld} for 1 min/5 min at 40 °C.

P_{Ld} Typical motor power in light-overload use.

Heavy-duty use

I_{Hd} Continuous current allowing 150% I_{Hd} for 1 min/5 min at 40 °C.

P_{Hd} Typical motor power in heavy-duty use.

The ratings apply at 40 °C ambient temperature. At higher temperatures (up to 55 °C) the derating is 1%/1 °C.

¹⁾ 130% overload

²⁾ 125% overload

³⁾ Comes with main power clamp

⁴⁾ 135% overload

Single drive modules, ACS880-04 and ACS880-04F

Our ACS880-04 and flange mounted ACS880-04F single drive modules are optimized for easy and cost efficient cabinet assembly. With a compact and robust cabinet design, they save a lot of floor space and are easy to maintain and service. Being part of the all-compatible ACS880 industrial drives series, the single drive modules are easy to integrate into other systems and they provide great control performance with versatile drive features. This power intensive drive module is compatible with a wide range of industries including oil and gas, mining, metals, chemicals, cement, power plants, material handling, pulp and paper and woodworking. Applications range from cranes, extruders, conveyors, compressors to pumps and fans.

Easy and cost efficient cabinet assembly

The module is designed with all the necessary components for making engineering, cabling and cabinet assembly easier. The module comes as a bookshelf and flat variant. It has a pedestal with wheels and a ramp for pushing the module inside the cabinet and connecting it to the optional cable panel. For optimized cabinet usage, features include power input connections on the top of the module and power output on the bottom. The control unit can be either installed inside or outside of the module, enabling free location of input/output terminals.

The built-in features include direct torque control (DTC), ABB's premier motor control technology, chokes for harmonic reduction, safe torque off (STO) and drive-to-drive communication as standard. Additional built-in options include EMC filters, braking chopper and common mode filters, several inputs/outputs terminals, fieldbus connectivity, integrated safety including several safety functions and option slots for speed feedback. The drive comes with IP20 enclosure class as standard, reducing engineering time and cabinet assembly costs.

ABB provides an extensive selection of support documentation for planning including dimension drawings in different formats, EPLAN P8 macros and line apparatus selection tool for selecting external components on the line side and motor side of the drive.

Main features

- Enclosure class IP20 as standard, in ACS880-04F (flange mounted) the external part is IP55
- Power supply coming from the top part of the module and out from the lower part of the cabinet, enabling more optimal cabinet design
- Possibility for flat mounting enables cabinet assembly even into cabinets with limited depth
- Easy installation, commissioning and maintenance with pedestal on wheels, ramp and optional cable panel (+H381)
- Direct torque control (DTC) as standard, for high performance motor control
- Integrated safety including safe torque off (STO) as standard and the optional safety functions module (TÜV Nord certified)
- Supports various motor types including synchronous reluctance motors
- Intuitive control panel with USB connection
- Removable memory unit for easy maintenance
- Drive composer PC tool for commissioning and configuration
- Control unit with three option slots, that can be installed either inside the module or in different parts of the cabinet, supporting a wide range of fieldbuses, feedback devices and input/output options
- Coated boards as standard
- Built-in choke as standard for input harmonics reduction
- Built-in braking chopper (option)
- EMC filter option
- Power terminals are available as standard on the left side of the module. The power terminals can also be cabled on the right side of the module as option
- ACS880-04XT, frame sizes R10 or R11 single drive modules can be parallel connected for higher powers
- ACS880-04XT can be connected as 6-pulse or as 12-pulse



Single drive modules, ACS880-04, frame sizes R10 (with external control unit) and R11 (with internal control unit and control panel integrated in the module), bookshelf mounting



Single drive modules, ACS880-04 (flat mounting), and ACS880-04F (flange mounting)



Optional cable panel installed inside the cabinet. ACS880-04 is pushed into the cabinet using a ramp and pedestal on wheels.

High power single drive module packages, ACS880-04

nxDxT supply units and nXR8i inverter units

The ACS880-04 high power single drives module packages include the parallel connected R8i inverter module and D8T half controlled diode bridge with thyristor charging. The power range is from 630 to 2200 kW, and the voltage range is from 380 to 690 V.

These compact multidrive modules come as bookshelf variants. They have been optimized for assembly into customer's own cabinets. Installing and transporting them is easy, as they come equipped with wheels. Connecting the modules to the motor cables inside the cabinet is quick as the modules come with quick connectors as standard. The modules can also be quickly pulled out from a cabinet without any need for disconnecting the motor cables. This is done simply by disconnecting a couple of bolts. The R8i inverter module comes equipped with a removable fan pedestal, which makes motor cabling easy.

The control unit and the input/output connections can be located in the most optimal part inside the cabinet. The circuit boards in the modules are in a sealed compartment, keeping them clean and cool during operation. The cooling fans in the module are speed controlled as a standard, helping to lower the noise level of the module and making it more energy efficient. The fans also make the temperature for the semiconductors more stable.

Main features

- Optimized design for easy cabinet assembly (comes with wheels)
- Compact bookshelf design
- Easy access to power terminals
- Side-by-side mounting
- Direct torque control (DTC) as standard, for high precision motor control
- Long lifetime cooling fan and capacitors
- Built-in redundancy with parallel connected modules
- Extensive, programmable inputs/output with galvanically isolated inputs
- Integrated safety including safe torque off (STO) as standard and the optional safety functions module (TÜV Nord certified)
- Supports various motor types including synchronous reluctance motors
- Removable memory unit for easy maintenance
- Drive composer PC tool for commissioning and configuration
- Control unit BCU-X2 is used with all parallel connected modules, such as nXR8i and DxT. It has three option slots, and a slot for DDCS optical communication
- The control unit can be installed in different parts of the cabinet, and it supports a wide range of fieldbuses, feedback devices and input/output options
- Coated boards come as standard
- Speed controlled cooling fans, or DOL as an option for certain frames
- Large power terminals allowing the use of a wide range of cable sizes
- Complete cabinet design for Rittal TS8 cabinets



ACS880-04 single drive module package with 1xD8T and 2xR8i

Ratings, types and voltages ACS880-04 /-04F, -04XT

U _N = 400 V (range 380 to 415 V). The power ratings are valid at nominal voltage 400 V (200 to 900 kW).												
Nominal ratings				Light-overload use		Heavy-duty use		Noise level	Heat dissipation	Air flow	Type designation	Frame size
I _N A	I _{max} A	I _{max_start} A	P _N kW	I _{Ld} A	P _{Ld} kW	I _{Hd} A	P _{Hd} kW	dB(A)	W	m ³ /h		
6-pulse												
505	560	671	250	485	250	361	200	72	5602	1200	ACS880-04-505A-3	R10
585	730	828	315	575	315	429	250	72	6409	1200	ACS880-04-585A-3	R10
650	730	954	355	634	355	477	250	72	8122	1200	ACS880-04-650A-3	R10
725	1020	1100	400	715	400	566	315	72	8764	1200	ACS880-04-725A-3	R11
820	1020	1100	450	810	450	625	355	72	9862	1200	ACS880-04-820A-3	R11
880	1100	1100	500	865	500	725 ¹⁾	400	71	10578	1420	ACS880-04-880A-3	R11
6- or 12-pulse												
1190	1343	-	630	1167	630	878	500	75	16244	2400	ACS880-04XT-1190A-3	2xR10
1610	2024	-	900	1570	900	1274 ¹⁾	710	74	21156	2840	ACS880-04XT-1610A-3	2xR11
U _N = 500 V (range 380 to 500 V). The power ratings are valid at nominal voltage 500 V (200 to 1000 kW).												
Nominal ratings				Light-overload use		Heavy-duty use		Noise level	Heat dissipation	Air flow	Type designation	Frame size
I _N A	I _{max} A	I _{max_start} A	P _N kW	I _{Ld} A	P _{Ld} kW	I _{Hd} A	P _{Hd} kW	dB(A)	W	m ³ /h		
6-pulse												
460	560	671	315	450	315	330	200	72	4403	1200	ACS880-04-460A-5	R10
503	560	671	355	483	315	361	250	72	5602	1200	ACS880-04-503A-5	R10
583	730	828	400	573	400	414	250	72	6409	1200	ACS880-04-583A-5	R10
635	730	954	450	623	450	477	315	72	8122	1200	ACS880-04-635A-5	R10
715	850	1100	500	705	500	566	400	72	8764	1200	ACS880-04-715A-5	R11
820	1020	1100	560	807	560	625	450	71	9862	1420	ACS880-04-820A-5	R11
880	1100	1100	630	857	560	697 ²⁾	500	71	11078	1420	ACS880-04-880A-5	R11
6- or 12-pulse												
1160	1343	-	800	1146	800	878	630	75	16244	2400	ACS880-04XT-1160A-5	2xR10
1610	2024	-	1000	1570	1000	1274 ²⁾	900	74	21156	2840	ACS880-04XT-1610A-5	2xR11
U _N = 690 V (range 525 to 690 V). The power ratings are valid at nominal voltage 690 V (250 to 1200 kW).												
Nominal ratings				Light-overload use		Heavy-duty use		Noise level	Heat dissipation	Air flow	Type designation	Frame size
I _N A	I _{max} A	I _{max_start} A	P _N kW	I _{Ld} A	P _{Ld} kW	I _{Hd} A	P _{Hd} kW	dB(A)	W	m ³ /h		
6-pulse												
330	480	510	315	320	315	255	250	72	4403	1200	ACS880-04-330A-7	R10
370	520	650	355	360	355	325	315	72	5602	1200	ACS880-04-370A-7	R10
430	540	720	400	420	450	360 ¹⁾	350	72	6409	1200	ACS880-04-430A-7	R10
470	655	830	450	455	450	415	400	72	8122	1200	ACS880-04-470A-7	R11
522	685	910	500	505	500	455	450	72	8764	1200	ACS880-04-522A-7	R11
590	800	1010	560	571	560	505	500	71	9862	1200	ACS880-04-590A-7	R11
650	825	1100	630	630	630	571 ³⁾	560	71	10578	1420	ACS880-04-650A-7	R11
721	825	1100	710	705	630	571 ³⁾	560	71	10578	1420	ACS880-04-721A-7	R11
6- or 12-pulse												
810	1168	-	800	791	710	678 ¹⁾	630	75	14140	2400	ACS880-04XT-0810A-7	2xR10
1080	1472	-	1000	1051	1000	929	900	75	16942	2400	ACS880-04XT-1080A-7	2xR11
1320	1509	-	1200	1297	1200	1051 ³⁾	1000	74	21354	2840	ACS880-04XT-1320A-7	2xR11

¹⁾ = 44% overload

²⁾ = 45% overload

³⁾ = 44% overload

Dimensions, ACS880-04, -04XT

Frame size	Height (mm)	Width (mm)	Depth (mm)	Weight (kg)
R10	1541 ¹⁾	350 ¹⁾	506	161
R11	1741 ¹⁾	350 ¹⁾	506	199

Dimensions, ACS880-04F

Frame size	Height (mm)	Width (mm)	Depth (mm)	Weight (kg)
R11	1647 ⁴⁾	620 ⁴⁾	404 ⁴⁾	230

⁴⁾ Without IP shrouds (+0B051) and full size output bus bars (+0H371) but with flange

Nominal ratings

I_N Rated current available continuously without overloadability at 40 °C.

P_N Typical motor power in no-overload use.

I_{max} Maximum output current. Available for 10 seconds at start, then as long as allowed by drive temperature.

I_{max_start} Maximum output current at start. When enabled, available for 2 seconds only at start every 7 seconds.

Light-overload use

I_{Ld} Continuous current allowing 110% I_{Ld} for 1 min/5 min at 40 °C.

P_{Ld} Typical motor power in light-overload use.

Heavy-duty use

I_{Hd} Continuous current allowing 150% I_{Hd} for 1 min/5 min at 40 °C.

P_{Hd} Typical motor power in heavy-duty use.

The ratings apply at 40 °C ambient temperature. At higher temperatures (up to 50 °C²⁾ or up to 55 °C³⁾) the derating is 1%/1 °C.

¹⁾ Without pedestal (+0H354) and without IP20 shrouds and full-size terminals (+0B051+0H371) height is 179 mm less and width 45 mm less. More information from HW manual.

²⁾ ACS880-04 high power single drive package.

³⁾ ACS880-04 single drive module.

Ratings, types and voltages ACS880-04 nxR8i

$U_N = 400 \text{ V}$ (range 380 to 415 V). The power ratings are valid at nominal voltage 400 V (400 to 1400 kW).

Nominal ratings			Light-overload use		Heavy-duty use		Noise level	Heat dissipation	Air flow	Type designation	Frame size
I_N A	I_{max} A	P_N kW	I_{Ld} A	P_{Ld} kW	I_{Hd} A	P_{Hd} kW	dB(A)	W	m ³ /h		
6-pulse											
1140	1482	630	1072	560	787	400	73	18000	4290	ACS880-04-1140A-3	D8T+2xR8i
1250	1630	710	1200	630	935	500	74	21000	5720	ACS880-04-1250A-3	2xD8T+2xR8i
1480	1930	800	1421	800	1107	630	74	25000	5720	ACS880-04-1480A-3	2xD8T+2xR8i
1760	2120	1000	1690	900	1316	710	74	29000	5720	ACS880-04-1760A-3	2xD8T+2xR8i
2210	2880	1200	2122	1200	1653	900	76	37000	8580	ACS880-04-2210A-3	3xD8T+3xR8i
2610	3140	1400	2506	1400	1952	1000	76	44000	8580	ACS880-04-2610A-3	3xD8T+3xR8i
12-pulse											
990	1287	560	950	500	741	400	73	15000	5720	ACS880-04-0990A-3+A004	2xD7T+2xR8i
1250	1630	710	1200	630	935	500	74	21000	5720	ACS880-04-1250A-3+A004	2xD8T+2xR8i
1480	1930	800	1421	800	1107	630	74	25000	5720	ACS880-04-1480A-3+A004	2xD8T+2xR8i
1760	2120	1000	1690	900	1316	710	74	29000	5720	ACS880-04-1760A-3+A004	2xD8T+2xR8i
2210	2880	1200	2122	1200	1653	900	76	35000	10010	ACS880-04-2210A-3+A004	4xD8T+3xR8i
2610	3140	1400	2506	1400	1952	1000	76	44000	10010	ACS880-04-2610A-3+A004	4xD8T+3xR8i

$U_N = 500 \text{ V}$ (range 380 to 500 V). The power ratings are valid at nominal voltage 500 V (560 to 1400 kW).

Nominal ratings			Light-overload use		Heavy-duty use		Noise level	Heat dissipation	Air flow	Type designation	Frame size
I_N A	I_{max} A	P_N kW	I_{Ld} A	P_{Ld} kW	I_{Hd} A	P_{Hd} kW	dB(A)	W	m ³ /h		
6-pulse											
1070	1391	710	1027	710	800	560	73	18000	4290	ACS880-04-1070A-5	D8T+2xR8i
1320	1716	900	1267	900	987	710	74	22000	5720	ACS880-04-1320A-5	2xD8T+2xR8i
1450	1890	1000	1392	900	1085	710	74	27000	5720	ACS880-04-1450A-5	2xD8T+2xR8i
1580	2060	1100	1517	1000	1182	800	74	32000	5720	ACS880-04-1580A-5	2xD8T+2xR8i
1800	2340	1250	1728	1200	1346	900	75	36000	7150	ACS880-04-1800A-5	2xD8T+3xR8i
1980	2574	1400	1901	1300	1481	1000	75	44500	7150	ACS880-04-1980A-5	2xD8T+3xR8i
12-pulse											
990	1287	710	950	630	741	500	73	16000	5720	ACS880-04-0990A-5+A004	2xD7T+2xR8i
1320	1716	900	1267	900	987	710	74	22000	5720	ACS880-04-1320A-5+A004	2xD8T+2xR8i
1450	1890	1000	1392	900	1085	710	74	25000	5720	ACS880-04-1450A-5+A004	2xD8T+2xR8i
1580	2060	1100	1517	1000	1182	800	74	27000	5720	ACS880-04-1580A-5+A004	2xD8T+2xR8i
1800	2340	1250	1728	1200	1346	900	75	32000	7150	ACS880-04-1800A-5+A004	2xD8T+3xR8i
1980	2574	1400	1901	1300	1481	1000	75	36000	7150	ACS880-04-1980A-5+A004	2xD8T+3xR8i

$U_N = 690 \text{ V}$ (range 525 to 690 V). The power ratings are valid at nominal voltage 690 V (560 to 2200 kW).

Nominal ratings			Light-overload use		Heavy-duty use		Noise level	Heat dissipation	Air flow	Type designation	Frame size
I_N A	I_{max} A	P_N kW	I_{Ld} A	P_{Ld} kW	I_{Hd} A	P_{Hd} kW	dB(A)	W	m ³ /h		
6-pulse											
800	1200	800	768	710	598	560	73	16000	4290	ACS880-04-0800A-7	D8T+2xR8i
900	1350	900	864	800	673	630	74	20000	4290	ACS880-04-0900A-7	D8T+2xR8i
1160	1740	1100	1114	1100	868	800	74	26000	5720	ACS880-04-1160A-7	2xD8T+2xR8i
1450	2175	1400	1392	1250	1085	1000	75	32000	7150	ACS880-04-1450A-7	2xD8T+3xR8i
1650	2475	1600	1584	1500	1234	1200	75	36500	7150	ACS880-04-1650A-7	2xD8T+3xR8i
2300	3450	2200	2208	2000	1720	1600	76	52000	10010	ACS880-04-2300A-7	3xD8T+4xR8i
12-pulse											
800	1200	800	768	710	598	560	73	16000	5720	ACS880-04-0800A-7+A004	2xD7T+2xR8i
950	1425	900	912	800	711	630	74	20000	5720	ACS880-04-0950A-7+A004	2xD8T+2xR8i
1160	1740	1100	1114	1100	868	800	74	26000	5720	ACS880-04-1160A-7+A004	2xD8T+2xR8i
1450	2175	1400	1392	1250	1085	1000	75	32000	7150	ACS880-04-1450A-7+A004	2xD8T+3xR8i
1650	2475	1600	1584	1500	1234	1200	75	36500	7150	ACS880-04-1650A-7+A004	2xD8T+3xR8i
2300	3450	2200	2208	2000	1720	1600	77	52000	11440	ACS880-04-2300A-7+A004	4xD8T+4xR8i

Dimensions

Frame size	Height (mm)	Width (mm)	Depth (mm)	Weight (kg)
R8i	1397	240	583	125
D7T	1178	170	417	80
D8T	1397	240	583	170

Regenerative single drive module package, ACS880-14

This single drive module package is a compact regenerative drive module solution. The package consists of R8i multidrive modules and a LCL line filter optimized for easy cabinet assembly. The ACS880-14 captures and utilizes energy which results in cost savings for the user.

With regenerative functionality, the braking energy of the motor is returned back to the drive and distributed forward to the supply network. This ensures that braking energy is not wasted as heat. In comparison with other braking methods, such as mechanical and resistor braking, the ACS880-14 brings much more energy savings. The module package is compatible with a broad range of industries including automotive, food and beverage, oil and gas, chemical, mining and metals. The drive is suitable for applications such as centrifuges, test benches conveyors, winches, elevators, pumps and fans.

High performance drives

The drive features direct torque control (DTC) as standard, enabling fast transition between motoring and generating mode in applications such as test benches and elevators. The drives active supply unit is able to boost output voltage, which guarantees full motor voltage even when the supply voltage is below nominal. The ACS880-14 reaches unity power factor.

Clear energy savings

Handling of waste heat may be a problem if the braking power is significant. The ACS880-14 does not need external braking devices, which makes drive installation simple as less need for cabinet space is required.

Simplified installation and connection

Installation of multidrive modules into cabinets is simplified with the use of mechanical and electrical accessories. These accessories are available giving full design to install the modules into Rittal TS8 cabinets. In addition, generic kits offer great help for installation of the modules into any other cabinet types that are available. Alternatively, ABB authorized and registered machine builders, system integrators and panel builders can manufacture their own accessory kits by accessing the online engineering support website which features detailed kit drawings. Cabinet assembly accessories help shorten engineering and assembly time as well as helping to reduce the risk of errors.

Main features

- Compact design for easy cabinet assembly and maintenance
- Optional air inlet and outlet kits available for enclosure classes IP20, IP42 and IP54
- LCL line filter
- Integrated safety including safe torque off (STO) as standard and the optional safety functions module (TÜV Nord certificate)
- Supports various motor types including synchronous reluctance motors
- Drive composer PC tool for commissioning and configuration
- Intuitive and easy to operate control panel with USB connection
- Device panel for optional switches and pilot lights
- Primary control program – common software used throughout the ACS880 drive series
- Control unit supporting a wide range of fieldbuses, feedback devices and input/output options
- Removable memory unit for easy maintenance
- Coated boards as standard
- Extensive, programmable digital and analog inputs and outputs
- Long lifetime capacitors
- Cooling fans with speed control or on-off control
- du/dt and common mode filter options for motor protection



Ratings, types and voltages ACS880-14

$U_N = 400\text{ V}$ (range 380 to 415 V). The power ratings are valid at nominal voltage 400 V (160 to 1400 kW).

Nominal ratings			Light-overload use		Heavy-duty use		Noise level	Heat dissipation	Air flow	Type designation	Frame size
I_N A	I_{max} A	P_N kW	I_{Ld} A	P_{Ld} kW	I_{Hd} A	P_{Hd} kW	dB(A)	W	m ³ /h		
450	590	250	432	200	337	160	75	14000	3760	ACS880-14-0450A-3	R8i + BLCL-13-5 + R8i
620	810	355	595	315	464	250	75	18000	3760	ACS880-14-0620A-3	R8i + BLCL-13-5 + R8i
870	1140	500	835	450	651	355	75	27000	3760	ACS880-14-0870A-3	R8i + BLCL-15-5 + R8i
1210	1580	710	1162	630	905	500	77	34000	7220	ACS880-14-1210A-3	2xR8i + BLCL-24-5 + 2xR8i
1430	1860	800	1373	710	1070	560	77	38000	7220	ACS880-14-1430A-3	2xR8i + BLCL-24-5 + 2xR8i
1700	2210	1000	1632	900	1272	710	77	51000	7220	ACS880-14-1700A-3	2xR8i + BLCL-25-5 + 2xR8i
2060	2680	1200	1978	1100	1541	800	78	61000	11580	ACS880-14-2060A-3	3xR8i + 2xBLCL-24-5 + 3xR8i
2530	3290	1400	2429	1200	1892	1000	78	76000	11580	ACS880-14-2530A-3	3xR8i + 2xBLCL-24-5 + 3xR8i

$U_N = 500\text{ V}$ (range 380 to 500 V). The power ratings are valid at nominal voltage 500 V (200 to 1600 kW).

Nominal ratings			Light-overload use		Heavy-duty use		Noise level	Heat dissipation	Air flow	Type designation	Frame size
I_N A	I_{max} A	P_N kW	I_{Ld} A	P_{Ld} kW	I_{Hd} A	P_{Hd} kW	dB(A)	W	m ³ /h		
420	550	250	403	250	314	200	75	13000	3760	ACS880-14-0420A-5	R8i + BLCL-13-5 + R8i
570	750	400	547	355	426	250	75	17000	3760	ACS880-14-0570A-5	R8i + BLCL-13-5 + R8i
780	1020	560	749	500	583	400	75	25000	3760	ACS880-14-0780A-5	R8i + BLCL-15-5 + R8i
1110	1450	800	1066	710	830	560	77	32000	7220	ACS880-14-1110A-5	2xR8i + BLCL-24-5 + 2xR8i
1530	1990	1100	1469	1000	1144	800	77	46000	7220	ACS880-14-1530A-5	2xR8i + BLCL-25-5 + 2xR8i
1980	2580	1400	1901	1300	1481	1000	78	59000	11580	ACS880-14-1980A-5	3xR8i + 2xBLCL-24-5 + 3xR8i
2270	2960	1600	2179	1500	1698	1200	78	69000	11580	ACS880-14-2270A-5	3xR8i + 2xBLCL-24-5 + 3xR8i

$U_N = 690\text{ V}$ (range 525 to 690 V). The power ratings are valid at nominal voltage 690 V (200 to 2200 kW).

Nominal ratings			Light-overload use		Heavy-duty use		Noise level	Heat dissipation	Air flow	Type designation	Frame size
I_N A	I_{max} A	P_N kW	I_{Ld} A	P_{Ld} kW	I_{Hd} A	P_{Hd} kW	dB(A)	W	m ³ /h		
320	480	315	307	250	239	200	75	16000	3760	ACS880-14-0320A-7	R8i + BLCL-13-7 + R8i
390	590	355	374	355	292	250	75	19000	3760	ACS880-14-0390A-7	R8i + BLCL-13-7 + R8i
580	870	560	557	500	434	400	75	26000	3760	ACS880-14-0580A-7	R8i + BLCL-15-7 + R8i
770	1160	710	739	710	576	560	77	34000	7220	ACS880-14-0770A-7	2xR8i + BLCL-24-7 + 2xR8i
950	1430	900	912	800	711	710	77	40000	7220	ACS880-14-0950A-7	2xR8i + BLCL-25-7 + 2xR8i
1130	1700	1100	1085	1000	845	800	77	48000	7220	ACS880-14-1130A-7	2xR8i + BLCL-25-7 + 2xR8i
1450	2180	1400	1392	1300	1085	1000	78	63000	11580	ACS880-14-1450A-7	3xR8i + 2xBLCL-24-7 + 3xR8i
1680	2520	1600	1613	1500	1257	1200	78	74000	11580	ACS880-14-1680A-7	3xR8i + 2xBLCL-24-7 + 3xR8i
2230	3350	2200	2141	2000	1668	1600	79	95000	14440	ACS880-14-2230A-7	4xR8i + 2xBLCL-25-7 + 4xR8i

Dimensions

Frame size	Height (mm)	Width (mm)	Depth (mm)	Weight (kg)
R8i	1397	240	585	125
BLCL-13-5	1397	240	505	181
BLCL-15-5	1397	240	505	224
BLCL-24-5	1397	240	581	320
BLCL-25-5	1397	240	581	324
BLCL-13-7	1397	240	505	178
BLCL-15-7	1397	240	505	217
BLCL-24-7	1397	240	581	301
BLCL-25-7	1397	240	581	310

Ultra-low harmonic single drives module package, ACS880-34

This single drive module package creates less harmonics compared to drives that offer standard diode supply solutions. The package consists of R8i multidrive modules and a LCL line filter optimized for easy cabinet assembly. The ACS880-34 produces exceptionally low harmonic content in the drives input. This is achieved without external filters or multi-pulse transformers. By managing and controlling harmonics, the drive reaches unity power factor. The active supply unit in the drive is able to boost output voltage, which guarantees full motor voltage even when the supply voltage is below nominal.

The ACS880-34 is compatible with a broad range of industries including oil and gas, chemical, mining, water and wastewater, cement and metals. The drive is suitable for applications such as pumps and fans, extruders, conveyors and compressors.

Improved harmonic performance

When compared to multi-pulse transformer solutions, the ACS800-34 does not require a dedicated transformer. For this reason, the cabinet-built low harmonic drive is simpler in terms of cabling arrangements and requires less floor space. Harmonic performance is also better when compared with 12- and 18-pulse solutions, handling online imbalance or other shortcomings in the supply network. Passive or active external filtering devices are avoided with the ACS800-34, making the solution compact and simple.

Simplified installation and connection

Installation of multidrive modules into cabinets is simplified with the use of mechanical and electrical accessories. These accessories are available giving full design to install

the modules into Rittal TS8 cabinets. In addition, generic kits offer great help for installing the modules into any other cabinet types that are available. Alternatively, ABB authorized and registered machine builders, system integrators and panel builders can manufacture their own accessory kits by accessing the online engineering support website which features detailed kit drawings. Cabinet assembly accessories help shorten engineering and assembly time as well as helping to reduce the risk of errors.

Main features

- Compact design for easy cabinet assembly and maintenance
- Optional air inlet and outlet kits available for enclosure classes IP20, IP42 and IP54
- LCL line filter
- Optional main switch and fuses
- Integrated safety including safe torque off (STO) as standard and the optional safety functions module (TÜV Nord certificate)
- Supports various motor types including synchronous reluctance motors
- Drive composer PC tool for commissioning and configuration
- Intuitive and easy to operate control panel with USB connection
- Device panel for optional switches and pilot lights
- Primary control program – common software used throughout the ACS880 drive series
- Control unit supporting a wide range of fieldbuses, feedback devices and input/output options
- Removable memory unit for easy maintenance
- Coated boards as standard
- Extensive, programmable digital and analog inputs and outputs
- Long lifetime capacitors
- Cooling fans with speed control or on-off control
- du/dt and common mode filter options for motor protection



Ratings, types and voltages ACS880-34

$U_N = 400 \text{ V}$ (range 380 to 415 V). The power ratings are valid at nominal voltage 400 V (160 to 1400 kW).

Nominal ratings			Light-overload use		Heavy-duty use		Noise level	Heat dissipation	Air flow	Type designation	Frame size
I_N A	I_{max} A	P_N kW	I_{Ld} A	P_{Ld} kW	I_{Hd} A	P_{Hd} kW	dB(A)	W	m ³ /h		
450	590	250	432	200	337	160	75	14000	3760	ACS880-34-0450A-3	R8i + BLCL-13-5 + R8i
620	810	355	595	315	464	250	75	18000	3760	ACS880-34-0620A-3	R8i + BLCL-13-5 + R8i
870	1140	500	835	450	651	355	75	27000	3760	ACS880-34-0870A-3	R8i + BLCL-15-5 + R8i
1210	1580	710	1162	630	905	500	77	34000	7220	ACS880-34-1210A-3	2xR8i + BLCL-24-5 + 2xR8i
1430	1860	800	1373	710	1070	560	77	38000	7220	ACS880-34-1430A-3	2xR8i + BLCL-24-5 + 2xR8i
1700	2210	1000	1632	900	1272	710	77	51000	7220	ACS880-34-1700A-3	2xR8i + BLCL-25-5 + 2xR8i
2060	2680	1200	1978	1100	1541	800	78	61000	11580	ACS880-34-2060A-3	3xR8i + 2xBLCL-24-5 + 3xR8i
2530	3290	1400	2429	1200	1892	1000	78	76000	11580	ACS880-34-2530A-3	3xR8i + 2xBLCL-24-5 + 3xR8i

$U_N = 500 \text{ V}$ (range 380 to 500 V). The power ratings are valid at nominal voltage 500 V (200 to 1600 kW).

Nominal ratings			Light-overload use		Heavy-duty use		Noise level	Heat dissipation	Air flow	Type designation	Frame size
I_N A	I_{max} A	P_N kW	I_{Ld} A	P_{Ld} kW	I_{Hd} A	P_{Hd} kW	dB(A)	W	m ³ /h		
420	550	250	403	250	314	200	75	13000	3760	ACS880-34-0420A-5	R8i + BLCL-13-5 + R8i
570	750	400	547	355	426	250	75	17000	3760	ACS880-34-0570A-5	R8i + BLCL-13-5 + R8i
780	1020	560	749	500	583	400	75	25000	3760	ACS880-34-0780A-5	R8i + BLCL-15-5 + R8i
1110	1450	800	1066	710	830	560	77	32000	7220	ACS880-34-1110A-5	2xR8i + BLCL-24-5 + 2xR8i
1530	1990	1100	1469	1000	1144	800	77	46000	7220	ACS880-34-1530A-5	2xR8i + BLCL-25-5 + 2xR8i
1980	2580	1400	1901	1300	1481	1000	78	59000	11580	ACS880-34-1980A-5	3xR8i + 2xBLCL-24-5 + 3xR8i
2270	2960	1600	2179	1500	1698	1200	78	69000	11580	ACS880-34-2270A-5	3xR8i + 2xBLCL-24-5 + 3xR8i

$U_N = 690 \text{ V}$ (range 525 to 690 V). The power ratings are valid at nominal voltage 690 V (200 to 2200 kW).

Nominal ratings			Light-overload use		Heavy-duty use		Noise level	Heat dissipation	Air flow	Type designation	Frame size
I_N A	I_{max} A	P_N kW	I_{Ld} A	P_{Ld} kW	I_{Hd} A	P_{Hd} kW	dB(A)	W	m ³ /h		
320	480	315	307	250	239	200	75	16000	3760	ACS880-34-0320A-7	R8i + BLCL-13-7 + R8i
390	590	355	374	355	292	250	75	19000	3760	ACS880-34-0390A-7	R8i + BLCL-13-7 + R8i
580	870	560	557	500	434	400	75	26000	3760	ACS880-34-0580A-7	R8i + BLCL-15-7 + R8i
770	1160	710	739	710	576	560	77	34000	7220	ACS880-34-0770A-7	2xR8i + BLCL-24-7 + 2xR8i
950	1430	900	912	800	711	710	77	40000	7220	ACS880-34-950A-7	2xR8i + BLCL-25-7 + 2xR8i
1130	1700	1100	1085	1000	845	800	77	48000	7220	ACS880-34-1130A-7	2xR8i + BLCL-25-7 + 2xR8i
1450	2180	1400	1392	1300	1085	1000	78	63000	11580	ACS880-34-1450A-7	3xR8i + 2xBLCL-24-7 + 3xR8i
1680	2520	1600	1613	1500	1257	1200	78	74000	11580	ACS880-34-1680A-7	3xR8i + 2xBLCL-24-7 + 3xR8i
2230	3350	2200	2141	2000	1668	1600	79	95000	14440	ACS880-34-2230A-7	4xR8i + 2xBLCL-25-7 + 4xR8i

Dimensions

Frame size	Height (mm)	Width (mm)	Depth (mm)	Weight (kg)
R8i	1397	240	585	125
BLCL-13-5	1397	240	505	181
BLCL-15-5	1397	240	505	224
BLCL-24-5	1397	240	581	320
BLCL-25-5	1397	240	581	324
BLCL-13-7	1397	240	505	178
BLCL-15-7	1397	240	505	217
BLCL-24-7	1397	240	581	301
BLCL-25-7	1397	240	581	310

Multidrive modules, ACS880-X04

Our ACS880 multidrive modules are designed to be built into a customers' own cabinets by machine builders and system integrators. The power of the inverter modules is available up to 3200 kW. The diode supply unit (DSU) is available up to 5445 kVA. The IGBT supply unit (ISU) is available up to 3679 kVA. The regenerative rectifier unit (RRU) is available up to 4135 kVA. All supply units offer supply voltages from 380 to 690 V. Multidrive modules are used for building multidrive configurations. The modules are used in industries such as metals, oil and gas, mining, marine, offshore, material handling machines, pulp and paper, automotive, food and beverage, cement, power, water and wastewater. They control a wide range of applications such as cranes, profile and flat rolling, conveyors, winches, test benches, processing lines, paper machines, pumps and fans. The multidrive modules are built using ABB's common drives architecture and are available in several frame sizes.

Rectifiers, inverters, brake options, filters, inputs and outputs options, communication option, documentation and everything else required for a complete drive is available. The drive can control motors in either open loop or closed loop through its high precision motor control platform, direct torque control (DTC). Built-in safety features reduce the need for external safety components.

Main features

- Compact design for easy cabinet assembly and maintenance
- Diode bridge that is highly reliable with high power density
- IGBT supply modules for regenerative drive systems with low harmonic distortion
- Regenerative rectifier unit (RRU) enables higher powers of the same power module
- Integrated safety including safe torque off (STO) as standard with several safety functions as options
- Drive composer PC tool for commissioning and configuration
- Intuitive control panel with USB connection
- Primary control program - common software used throughout the ACS880 drive series
- Control unit ZCU for inverter modules (frame sizes R1i to R7i and diode supply modules DxD and IGBT supply modules R1i to R6i) comes with three option slots for extension option modules

- IGBT supply modules (frame size n×R8i), inverter modules (n×R8i), diode supply modules (n×DxT) and Regenerative rectifier unit (n×R8i) uses the BCU control unit that comes with integrated branching unit, power stage link data logger with detachable memory card, embedded Ethernet and three option slots with an additional slot for DDCS communication option
- Supports various motor types including synchronous reluctance motors
- Removable memory unit for easy maintenance
- Coated boards as standard
- Braking options
- Cabinet accessory kits
- Optional installation frames for mounting multidrive modules
- Detailed documentation for cabinet assembly

Simplified installation and connection

Installation of multidrive modules into cabinets is simplified with the use of mechanical and electrical accessories. These accessories are available giving full design to install the modules into Rittal TS8 cabinets. In addition, generic kits offer great help to install the modules into any other cabinet types that are available. Alternatively, ABB authorized and registered machine builders, system integrators and panel builders can manufacture their own accessory kits by accessing the online engineering support website which features detailed kit drawings. Cabinet assembly accessories help shorten engineering and assembly time as well as reduce the risk of errors.

Using our cabinet assembly accessories and part drawings enables easy and efficient installation, making sourcing the mechanical components more flexible. Other benefits that reduce time required for mechanical engineering include dimensional and assembly drawings with accessories drawings available as 3D models, EPLAN electric P8 macros, module circuit diagrams and installation example videos and animations for cabinets. Training material for cabinet assembly of drives is also available.



Multidrive modules, ACS880-X04

The modules have a side-by-side mounting on the assembly plate situated in the cabinet, making module installation faster and easier. Modules with bigger frame sizes are equipped with wheels so they can easily be moved in or out of the cabinet for maintenance purposes. This concept also allows pre-installation of the power cables inside the empty cabinet. Besides the compact design, the new ACS880 inverter and rectifier units include an extensive selection of options.

The multidrive construction simplifies the total installation and provides many advantages such as:

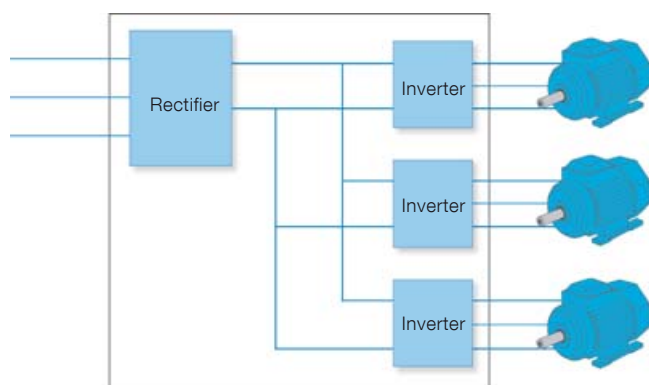

- Savings in cabling, installation and maintenance costs
- Space savings
- Reduced component count and increased reliability
- Reduced line currents and simpler braking arrangements
- Energy circulation over the common DC busbar, which can be used for motor-to-motor braking without the need for a braking chopper or regenerative supply unit
- Optimized and simple cabinet

Inverter units (INU)

Inverter units come in 8 different frame sizes. Frame sizes R1i to n×R8i start from 1.5 to 3200 kW. The voltage ranges from 380 to 690 V. Inverter units have built-in capacitors for smoothing the voltage of the DC busbars. The electrical connection to the common DC busbar is fuse protected. An optional switch can be selected to disconnect the whole drive unit from the DC bus. Each inverter unit comes with safe torque off (STO) as standard and has a control unit (ZCU/BCU) which has slots to place different option adapters, such as input/output extension modules, speed feedback modules and fieldbus adapter modules.

Diode supply units (DSU)

A diode supply unit is used in non-regenerative drive systems to convert three-phase AC voltage to DC voltage. Multidrive has two different diode supply unit types. One of these is a diode supply unit (D6D to D8D) for power range 60 to 850 kVA that has no charging circuit. The charging is built into the drive units (R1i to R7i). This diode supply unit is controlled by the ZCU control unit.

The other one is a diode supply unit (D7T and D8T) for power range 340 to 5445 kVA, built with 1 to 6 parallel units. This half controlled diode supply unit has thyristor charging, BCU control unit and 6-pulse and 12-pulse versions available.



Frame sizes R1i to R8i

Frame sizes D6D to D8D and D8T

IGBT supply units (ISU)

IGBT supply units are used in regenerative drives to convert three-phase AC voltage to DC voltage. These units are available from R1i to R4i, R6i and n×R8i frame size with LCL line filter in a power range from 5.5 to 6131 kVA. With regard to power control, it gives the same firm but gentle performance as direct torque control (DTC) gives in motor control. The IGBT module is hardware compatible with drive modules and it can operate in both motoring and generating modes.

The DC voltage is constant and the line current is sinusoidal. The control also provides a near unity power factor. The module can also boost DC voltages eg, when line voltage is low. Harmonic content remains extremely low due to DTC control and LCL line filtering.

Regenerative rectifier unit (RRU)

This supply unit is used in regenerative drive systems to convert three-phase AC voltage to DC voltage. The RRU is made of n×R8i inverter units and L filters. The IGBTs' are switched conducting only once during each network voltage cycle. This reduces switching losses and enables higher powers of the same power module. Operation of RRU is also reliable during supply network voltage variations.

Brake unit

Brake unit handles the energy generated by decelerating motors such as emergency stopping. During resistor braking, whenever the voltage in the intermediate circuit of a drive exceeds a certain limit, a braking chopper connects the circuit to a braking resistor.

Offering includes 1-phase brake unit and 3-phase dynamic brake unit (DBU) which utilizes R8i modules.

DC-DC converter (DDC)

DC-DC converter transfers energy from a common DC link of an multidrives into an external energy storage. From there it discharges energy back to the DC link. Energy storages can be batteries or super capacitors. Typical applications can be in marine (heave and peak load compensation) and automotive (battery simulators in test benches and electric car charging systems) industries.

Ratings, types and voltages Inverter modules

Inverter modules (INU), ACS880-104

$U_N = 400$ V (range 380 to 415 V). The power ratings are valid at nominal voltage 400 V (1.5 to 2800 kW).

Nominal ratings			Light-overload use		Heavy-duty use		Noise level	Heat dissipation	Air flow	Type designation	Frame size
I_N A (AC)	I_{max} A (AC)	P_N kW	I_{Ld} A	P_{Ld} kW	I_{Hd} A	P_{Hd} kW	dB(A)	kW	m ³ /h		
4.8	7	1.5	4.5	1.5	4	1.5	47	0.07	24	ACS880-104-004A8-3	R1i
6	8.8	2.2	5.5	2.2	5	1.5	47	0.08	24	ACS880-104-006A0-3	R1i
8	10.5	3	7.6	3	6	2.2	47	0.09	24	ACS880-104-008A0-3	R1i
10.5	13.5	4	9.7	4	9	3	39	0.11	48	ACS880-104-0011A-3	R2i
14	16.5	5.5	13	5.5	11	4	39	0.14	48	ACS880-104-0014A-3	R2i
18	21	7.5	16.8	7.5	14	5.5	39	0.17	48	ACS880-104-0018A-3	R2i
25	33	11	23	11	19	7.5	63	0.20	142	ACS880-104-0025A-3	R3i
35	44	15	32	15	29	11	63	0.30	142	ACS880-104-0035A-3	R3i
44	53	18.5	41	18.5	35	15	71	0.35	200	ACS880-104-0044A-3	R3i
50	66	22	46	22	44	22	71	0.41	200	ACS880-104-0050A-3	R3i
61	78	30	57	30	52	22	70	0.50	290	ACS880-104-0061A-3	R4i
78	100	37	74	37	69	30	70	0.60	290	ACS880-104-0078A-3	R4i
94	124	45	90	45	75	37	70	0.74	290	ACS880-104-0094A-3	R4i
104	125	55	100	55	78	37	70	0.75	290	ACS880-104-0100A-3	R4i
141	183	75	135	75	105	55	71	1.1	650	ACS880-104-0140A-3	R6i
169	220	90	162	90	126	55	71	1.4	650	ACS880-104-0170A-3	R6i
206	268	110	198	110	154	75	71	1.8	650	ACS880-104-0210A-3	R6i
246	320	132	236	132	184	90	71	2.0	650	ACS880-104-0250A-3	R6i
300	390	160	288	160	224	110	72	2.5	940	ACS880-104-0300A-3	R7i
350	455	200	336	160	262	132	72	3.1	940	ACS880-104-0350A-3	R7i
470	620	250	451	250	352	160	72	4.8	1300	ACS880-104-0470A-3	R8i
640	840	355	614	315	479	250	72	6.7	1300	ACS880-104-0640A-3	R8i
760	990	400	730	400	568	315	72	8	1300	ACS880-104-0760A-3	R8i
900	1080	500	864	450	673	355	72	10	1300	ACS880-104-0900A-3	R8i
1250	1630	630	1200	630	935	500	74	13	2600	ACS880-104-1250A-3	2xR8i
1480	1930	800	1421	800	1107	630	74	16	2600	ACS880-104-1480A-3	2xR8i
1760	2120	1000	1690	900	1316	710	74	20	2600	ACS880-104-1760A-3	2xR8i
2210	2880	1200	2122	1200	1653	900	76	23	3900	ACS880-104-2210A-3	3xR8i
2610	3140	1400	2506	1400	1952	1000	76	30	3900	ACS880-104-2610A-3	3xR8i
3450	4140	1800	3312	1800	2581	1400	76	40	5200	ACS880-104-3450A-3	4xR8i
4290	5150	2400	4118	2000	3209	1800	77	50	6500	ACS880-104-4290A-3	5xR8i
5130	6160	2800	4925	2400	3837	2000	78	60	7800	ACS880-104-5130A-3	6xR8i

Dimensions

Frame size	Height (mm)	Width (mm)	Depth (mm)	Weight (kg)
R1i	364	90	234	4
R2i	380	100	312	6
R3i	467	168	313	11
R4i	467	223	313	18
R6i	890	170	456	38
R7i	890	170	456	39
R8i	1397	240	583	125

With module covers and without strain relief clamps (R1i to R4i)

Nominal ratings

I_N	Rated current available continuously without overloadability at 40 °C.
S_N	Nominal apparent power.
P_N	Typical motor power in no-overload use.
I_{max}	Maximum output current. Available for 10 seconds at start, otherwise as long as allowed by drive temperature.

Light-overload use

I_{Ld}	Continuous current allowing 110% I_{Ld} for 1 min/5 min at 40 °C.
P_{Ld}	Typical motor power in light-overload use.

Heavy-duty use

I_{Hd}	Continuous current allowing 150% I_{Hd} for 1 min/5 min at 40 °C.
P_{Hd}	Typical motor power in heavy-duty use.

The ratings apply at 40 °C ambient temperature. At higher temperatures (up to 50 °C) the derating is 1%/1 °C.

- ¹⁾ +A003 Uncontrolled diode bridge
- +A018 Half-controlled diode bridge
- +A004 12-pulse DSU

Ratings, types and voltages Supply units

IGBT supply modules (ISU), ACS880-204

$U_N = 400\text{ V}$ (range 380 to 415 V). The power ratings are valid at nominal voltage 400 V (5.5 to 3319 kVA).

Nominal ratings				No-overload use	Light-overload use		Heavy-duty use		Noise level	Heat dissipation	Air flow	Type designation	Frame size
I_N A (AC)	I_N A (DC)	I_{max} A (DC)	S_N kVA	P_N kW (DC)	I_{Ld} A (DC)	P_{Ld} kW (DC)	I_{Hd} A (DC)	P_{Hd} kW (DC)	dB(A)	kW	m ³ /h		
8	10	12.6	5.5	5.5	9.3	5.3	7.3	4.1	47	0.22	24	ACS880-204-008A0-3	R1i+WFU-01
18	22	28	12	12	21	12	16	9	39	0.5	48	ACS880-204-0018A-3	R2i+WFU-02
35	42	55	24	24	41	23	32	18	63	0.97	63	ACS880-204-0035A-3	R3i+WFU-11
50	61	79	35	34	58	33	45	26	71	1.39	200	ACS880-204-0050A-3	R3i+WFU-21
93	113	147	64	64	108	61	84	48	70	2.58	290	ACS880-204-0093A-3	R4i+WFU-22
210	255	331	145	144	244	138	190	108	72	4.1	1150	ACS880-204-0210A-3	R6i+ALCL-05-5
423	513	667	293	290	492	279	384	217	72	9.2	2200	ACS880-204-0420A-3	R8i+BLCL-13-5
576	698	908	399	395	670	379	522	296	72	12	2200	ACS880-204-0580A-3	R8i+BLCL-13-5
810	982	1277	561	556	943	533	735	416	72	17.5	2200	ACS880-204-0810A-3	R8i+BLCL-15-5
1125	1364	1773	779	772	1309	741	1020	577	74	21.5	4100	ACS880-204-1130A-3	2xR8i+BLCL-24-5
1332	1615	2100	923	914	1550	877	1208	683	74	24	4100	ACS880-204-1330A-3	2xR8i+BLCL-24-5
1584	1921	2497	1097	1086	1844	1043	1437	813	74	31.8	4100	ACS880-204-1580A-3	2xR8i+BLCL-25-5
2349	2848	3703	1627	1611	2734	1547	2130	1205	76	47.1	6900	ACS880-204-2350A-3	3xR8i+2xBLCL-24-5
3105	3765	4894	2151	2130	3614	2045	2816	1593	76	63.1	8200	ACS880-204-3110A-3	4xR8i+2xBLCL-25-5
4617	5598	7278	3199	3167	5374	3040	4187	2369	78	94.6	12300	ACS880-204-4620A-3	6xR8i+3xBLCL-25-5

Regenerative rectifier units (RRU), ACS880-904

$U_N = 400\text{ V}$ (range 380 to 415 V). The power ratings are valid at nominal voltage 400 V (416 to 2397 kVA).

640	727	955	416	393	698	377	544	294	72	8.4	2200	ACS880-904-0600A-3	1xR8i + BL-15-5
900	1091	1433	624	589	1048	566	816	441	72	12.9	2200	ACS880-904-0900A-3	1xR8i + BL-15-5
1180	1431	1879	818	773	1374	742	1070	578	74	15.7	4100	ACS880-904-1180A-3	2xR8i + BL-25-5
1770	2146	2818	1226	1159	2060	1113	1605	867	74	25.2	4100	ACS880-904-1770A-3	2xR8i + BL-25-5
2310	2801	3678	1600	1512	2689	1452	2095	1131	76	31.5	8200	ACS880-904-2310A-3	4xR8i + 2xBL-25-5
3460	4195	5509	2397	2265	4027	2175	3138	1695	76	50.4	8200	ACS880-904-3460A-3	4xR8i + 2xBL-25-5

Diode supply modules (DSU), ACS880-304

$U_N = 400\text{ V}$ (range 380 to 415 V). The power ratings are valid at nominal voltage 400 V (55 to 3788 kVA).

Nominal ratings				No-overload use	Light-overload use		Heavy-duty use		Noise level	Heat dissipation	Air flow	Type designation ¹⁾	Frame size
I_N A (AC)	I_N A (DC)	I_{max} A (DC)	S_N kVA	P_N kW (DC)	I_{Ld} A (DC)	P_{Ld} kW (DC)	I_{Hd} A (DC)	P_{Hd} kW (DC)	dB(A)	kW	m ³ /h		
6-pulse diode													
80	98	137	55	53	94	51	78	42	62	0.8	370	ACS880-304-0080A-3+A003	D6D
173	212	297	120	114	203	110	170	92	62	1.3	370	ACS880-304-0170A-3+A003	D6D
327	400	561	227	216	384	208	320	173	62	2	720	ACS880-304-0330A-3+A003	D7D
490	600	840	339	324	576	311	480	259	62	3	720	ACS880-304-0490A-3+A003	D7D
653	800	1120	452	432	768	415	640	345	65	4.5	900	ACS880-304-0650A-3+A003	D8D
980	1200	1680	679	648	1152	622	960	519	65	6	900	ACS880-304-0980A-3+A003	D8D
653	800	1120	453	432	768	415	598	323	72	5	1300	ACS880-304-0650A-3+A018	D8T
980	1200	1680	679	648	1152	622	898	485	72	7	1300	ACS880-304-0980A-3+A018	D8T
1215	1488	2083	842	804	1428	771	1113	601	74	9	2600	ACS880-304-1210A-3+A018	2xD8T
1822	2232	3125	1263	1205	2143	1157	1670	902	74	13	2600	ACS880-304-1820A-3+A018	2xD8T
2734	3348	4687	1894	1808	3214	1736	2504	1352	76	20	3900	ACS880-304-2730A-3+A018	3xD8T
3645	4464	6250	2525	2411	4285	2314	3339	1803	76	27	5200	ACS880-304-3640A-3+A018	4xD8T
4556	5580	7812	3157	3013	5357	2893	4174	2254	77	33	6500	ACS880-304-4560A-3+A018	5xD8T
5467	6696	9374	3788	3616	6428	3471	5009	2705	78	40	7800	ACS880-304-5470A-3+A018	6xD8T
12-pulse diode													
911	1116	1562	631	625	1071	600	835	467	74	8	1800	ACS880-304-0910A-3+A004+A018	2xD7T
1215	1488	2083	842	833	1428	800	1113	623	74	9	2600	ACS880-304-1210A-3+A004+A018	2xD8T
1822	2232	3125	1263	1250	2143	1200	1670	935	74	13	2600	ACS880-304-1820A-3+A004+A018	2xD8T
2430	2976	4166	1683	1667	2857	1600	2226	1247	76	18	5200	ACS880-304-2430A-3+A004+A018	4xD8T
3645	4464	6250	2525	2500	4285	2400	3339	1870	76	27	5200	ACS880-304-3640A-3+A004+A018	4xD8T
5467	6696	9374	3788	3750	6428	3600	5009	2805	78	40	7800	ACS880-304-5470A-3+A004+A018	6xD8T

Dimensions

Frame size	Height (mm)	Width (mm)	Depth (mm)	Weight (kg)
IGBT supply unit (ISU)				
R1i	364	90	234	4
R2i	380	100	312	6
R3i	467	168	313	11
R4i	467	223	313	18
R6i	900	170	456	38
R8i	1397	240	583	125
LCL-line filter for IGBT supply unit (ISU)				
WFU-01	315	213	218	11
WFU-02	315	213	218	11
WFU-11	386	288	256	34
WFU-21	406	318	299	45
WFU-22	406	318	299	51
ALCL-05-5	845	378	305	100
BLCL-13-5	1397	240	505	181
BLCL-15-5	1397	240	505	224
BLCL-24-5	1397	240	581	320
BLCL-25-5	1397	240	581	324
Regenerative rectifier unit (RRU)				
R8i	1397	240	583	125
BL-15-5	1397	240	444	155
BL-25-5	1397	240	549	215
Diode supply modules (DSU)				
D6D	815	170	408	37
D7D	1054	170	417	73
D8D	1397	240	582	173
D7T	1178	170	417	80
D8T	1397	240	589	180

Ratings, types and voltages Inverter modules

Inverter modules (INU), ACS880-104

$U_N = 500 \text{ V}$ (range 380 to 500 V). The power ratings are valid at nominal voltage 500 V (1.5 to 3200 kW).

Nominal ratings			Light-overload use		Heavy-duty use		Noise level	Heat dissipation	Air flow	Type designation	Frame size
I_N A (AC)	I_{max} A (AC)	P_N kW	I_{Ld} A	P_{Ld} kW	I_{Hd} A	P_{Hd} kW	dB(A)	kW	m ³ /h		
3.6	5.3	1.5	3.4	1.5	3	1.5	47	0.06	24	ACS880-104-003A6-5	R1i
4.8	7	2.2	4.5	2.2	4	1.5	47	0.07	24	ACS880-104-004A8-5	R1i
6	8.8	3	5.5	3	5	2.2	47	0.08	24	ACS880-104-006A0-5	R1i
8	10.5	4	7.6	4	6	3	47	0.09	24	ACS880-104-008A0-5	R1i
10.5	13.5	5.5	9.7	5.5	9	4	39	0.13	48	ACS880-104-0011A-5	R2i
14	16.5	7.5	13	7.5	11	5.5	39	0.15	48	ACS880-104-0014A-5	R2i
18	21	11	16.8	11	14	7.5	39	0.18	48	ACS880-104-0018A-5	R2i
25	33	15	23	15	19	11	63	0.23	142	ACS880-104-0025A-5	R3i
30	36	18.5	28	18.5	24	15	63	0.28	142	ACS880-104-0030A-5	R3i
35	44	22	32	22	29	18.5	63	0.32	142	ACS880-104-0035A-5	R3i
50	66	30	46	30	44	22	71	0.48	200	ACS880-104-0050A-5	R3i
61	78	37	57	37	52	30	70	0.55	290	ACS880-104-0061A-5	R4i
78	100	45	74	45	69	45	70	0.65	290	ACS880-104-0078A-5	R4i
94	124	55	90	55	75	45	70	0.80	290	ACS880-104-0094A-5	R4i
113	147	75	108	75	85	55	71	1	650	ACS880-104-0110A-5	R6i
136	177	90	131	90	102	55	71	1.2	650	ACS880-104-0140A-5	R6i
165	215	110	158	110	123	75	71	1.5	650	ACS880-104-0170A-5	R6i
197	256	132	189	132	147	90	71	1.8	650	ACS880-104-0200A-5	R6i
240	312	160	230	160	180	110	71	2.0	650	ACS880-104-0240A-5	R6i
302	393	200	290	200	226	132	72	2.7	940	ACS880-104-0300A-5	R7i
340	442	250	326	200	254	160	72	3.2	940	ACS880-104-0340A-5	R7i
440	580	250	422	250	329	200	72	4.7	1300	ACS880-104-0440A-5	R8i
590	770	400	566	355	441	250	72	6.3	1300	ACS880-104-0590A-5	R8i
740	970	500	710	450	554	355	72	8.1	1300	ACS880-104-0740A-5	R8i
810	1060	560	778	500	606	400	72	9.3	1300	ACS880-104-0810A-5	R8i
1150	1500	800	1104	710	860	560	74	12	2600	ACS880-104-1150A-5	2xR8i
1450	1890	1000	1392	900	1085	710	74	16	2600	ACS880-104-1450A-5	2xR8i
1580	2060	1100	1517	1000	1182	800	74	18	2600	ACS880-104-1580A-5	2xR8i
2150	2800	1500	2064	1400	1608	1100	76	24	3900	ACS880-104-2150A-5	3xR8i
2350	3060	1600	2256	1500	1758	1200	76	27	3900	ACS880-104-2350A-5	3xR8i
3110	4050	2000	2986	2000	2326	1600	76	36	5200	ACS880-104-3110A-5	4xR8i
3860	5020	2400	3706	2400	2887	2000	77	44	6500	ACS880-104-3860A-5	5xR8i
4610	6000	3200	4426	2800	3448	2400	78	53	7800	ACS880-104-4610A-5	6xR8i

Dimensions

Frame size	Height (mm)	Width (mm)	Depth (mm)	Weight (kg)
R1i	364	90	234	4
R2i	380	100	312	6
R3i	467	168	313	11
R4i	467	223	313	18
R6i	890	170	456	38
R7i	890	170	456	39
R8i	1397	240	583	125

With module covers and without strain relief clamps (R1i to R4i)

Nominal ratings

I_N	Rated current available continuously without overloadability at 40 °C.
S_N	Nominal apparent power.
P_N	Power in no-overload use.
I_{max}	Maximum output current. Available for 10 seconds at start, otherwise as long as allowed by drive temperature.

Light-overload use

I_{Ld}	Continuous current allowing 110% I_{Ld} for 1 min/5 min at 40 °C.
P_{Ld}	Power in light-overload use.

Heavy-duty use

I_{Hd}	Continuous current allowing 150% I_{Hd} for 1 min/5 min at 40 °C.
P_{Hd}	Power in heavy-duty use.

The ratings apply at 40 °C ambient temperature. At higher temperatures (up to 50 °C) the derating is 1%/1 °C.

- ¹⁾ +A003 Uncontrolled diode bridge
+A018 Half-controlled diode bridge
+A004 12-pulse DSU

Ratings, types and voltages Supply units

IGBT supply modules (ISU), ACS880-204

$U_N = 500$ V (range 380 to 500 V). The power ratings are valid at nominal voltage 500 V (5.7 to 3593 kVA).

Nominal ratings				No-overload use	Light-overload use		Heavy-duty use		Noise level	Heat dissipation	Air flow	Type designation	Frame size
I_N A (AC)	I_N A (DC)	I_{max} A (DC)	S_N kVA	P_N kW (DC)	I_{Ld} A (DC)	P_{Ld} kW (DC)	I_{Hd} A (DC)	P_{Hd} kW (DC)	dB(A)	kW	m ³ /h		
6.6	8	10.4	5.7	6	7.7	5.4	6	4.2	47	0.22	24	ACS880-204-006A6-5	R1i+WFU-01
15	18	24	13	13	17	12.3	14	9.6	39	0.5	48	ACS880-204-0015A-5	R2i+WFU-02
29	35	46	25.1	25	34	23.9	26	18.6	63	0.97	63	ACS880-204-0029A-5	R3i+WFU-11
41	50	65	35.5	35	48	33.7	37	26.3	71	1.39	200	ACS880-204-0041A-5	R3i+WFU-21
77	93	121	66.7	66	90	63.4	70	49.4	70	2.58	290	ACS880-204-0077A-5	R4i+WFU-22
210	255	331	182	180	244	173	190	135	72	4.2	1150	ACS880-204-0210A-5	R6i+ALCL-05-5
396	480	624	343	340	461	326	359	254	72	9.2	2200	ACS880-204-0400A-5	R8i+BLCL-13-5
531	644	837	460	455	618	437	482	341	72	11.5	2200	ACS880-204-0530A-5	R8i+BLCL-13-5
729	884	1149	631	625	849	600	661	468	72	16.7	2200	ACS880-204-0730A-5	R8i+BLCL-15-5
1035	1255	1631	896	887	1205	852	939	664	74	20.8	4100	ACS880-204-1040A-5	2xR8i+BLCL-24-5
1422	1724	2241	1231	1219	1655	1170	1290	912	74	29.4	4100	ACS880-204-1420A-5	2xR8i+BLCL-25-5
2115	2564	3334	1832	1813	2462	1741	1918	1356	76	43.9	6900	ACS880-204-2120A-5	3xR8i+2xBLCL-24-5
2799	3394	4412	2424	2400	3258	2304	2539	1795	76	58.5	8200	ACS880-204-2800A-5	4xR8i+2xBLCL-25-5
4149	5031	6540	3593	3557	4829	3415	3763	2661	78	87.6	12300	ACS880-204-4150A-5	6xR8i+3xBLCL-25-5

Regenerative rectifier units (RRU), ACS880-904

$U_N = 500$ V (range 230 to 525 V). The power ratings are valid at nominal voltage 500 V (520 to 2996 kVA).

600	727	955	520	491	698	471	544	367	72	8.5	2200	ACS880-904-0600A-5	1xR8i + BL-15-5
900	1091	1433	779	737	1047	707	816	551	72	13	2200	ACS880-904-0900A-5	1xR8i + BL-15-5
1180	1431	1879	1022	966	1374	927	1070	722	74	16.1	4100	ACS880-904-1180A-5	2xR8i + BL-25-5
1770	2146	2818	1533	1449	2060	1391	1605	1084	74	25.6	4100	ACS880-904-1770A-5	2xR8i + BL-25-5
2310	2801	3678	2001	1891	2689	1815	2095	1414	76	32.2	8200	ACS880-904-2310A-5	4xR8i + 2xBL-25-5
3460	4195	5509	2996	2832	4027	2719	3138	2118	76	51.1	8200	ACS880-904-3460A-5	4xR8i + 2xBL-25-5

Diode supply modules (DSU), ACS880-304

$U_N = 500$ V (range 380 to 500 V). The power ratings are valid at nominal voltage 500 V (69 to 4735 kVA).

Nominal ratings				No-overload use	Light-overload use		Heavy-duty use		Noise level	Heat dissipation	Air flow	Type designation ¹⁾	Frame size
I_N A (AC)	I_N A (DC)	I_{max} A (DC)	S_N kVA	P_N kW (DC)	I_{Ld} A (DC)	P_{Ld} kW (DC)	I_{Hd} A (DC)	P_{Hd} kW (DC)	dB(A)	kW	m ³ /h		
6-pulse diode													
80	98	137	69	66	94	63	78	53	62	0.8	370	ACS880-304-0080A-5+A003	D6D
173	212	297	150	143	203	137	170	114	62	1.3	370	ACS880-304-0170A-5+A003	D6D
327	400	561	283	270	384	260	320	216	62	2	720	ACS880-304-0330A-5+A003	D7D
490	600	840	424	405	576	389	480	324	62	3	720	ACS880-304-0490A-5+A003	D7D
653	800	1120	566	540	768	518	640	432	65	4.5	900	ACS880-304-0650A-5+A003	D8D
980	1200	1680	849	810	1152	778	960	648	65	6	900	ACS880-304-0980A-5+A003	D8D
653	800	1120	566	540	768	518	598	404	72	5	1300	ACS880-304-0650A-5+A018	D8T
980	1200	1680	849	810	1152	778	898	606	72	7	1300	ACS880-304-0980A-5+A018	D8T
1215	1488	2083	1052	1004	1428	964	1113	751	74	9	2600	ACS880-304-1210A-5+A018	2xD8T
1822	2232	3125	1578	1507	2143	1446	1670	1127	74	13	2600	ACS880-304-1820A-5+A018	2xD8T
2734	3348	4687	2367	2260	3214	2170	2504	1690	76	20	3900	ACS880-304-2730A-5+A018	3xD8T
3645	4464	6250	3157	3013	4285	2893	3339	2254	76	27	5200	ACS880-304-3640A-5+A018	4xD8T
4556	5580	7812	3946	3767	5357	3616	4174	2817	77	33	6500	ACS880-304-4560A-5+A018	5xD8T
5467	6696	9374	4735	4520	6428	4339	5009	3381	78	40	7800	ACS880-304-5470A-5+A018	6xD8T
12-pulse diode													
911	1116	1562	789	781	1071	750	835	584	74	8	1800	ACS880-304-0910A-5+A004+A018	2xD7T
1215	1488	2083	1052	1042	1428	1000	1113	779	74	9	2600	ACS880-304-1210A-5+A004+A018	2xD8T
1822	2232	3125	1578	1562	2143	1500	1670	1169	74	13	2600	ACS880-304-1820A-5+A004+A018	2xD8T
2430	2976	4166	2104	2073	2857	2000	2226	1558	76	18	5200	ACS880-304-2430A-5+A004+A018	4xD8T
3645	4464	6250	3157	3125	4285	3000	3339	2337	76	27	5200	ACS880-304-3640A-5+A004+A018	4xD8T
5467	6696	9374	4735	4687	6428	4500	5009	3506	78	40	7800	ACS880-304-5470A-5+A004+A018	6xD8T

Dimensions

Frame size	Height (mm)	Width (mm)	Depth (mm)	Weight (kg)	Frame size	Height (mm)	Width (mm)	Depth (mm)	Weight (kg)
IGBT supply unit (ISU)					Regenerative rectifier unit (RRU)				
R1i	364	90	234	4	R8i	1397	240	583	125
R2i	380	100	312	6	BL-15-5	1397	240	444	155
R3i	467	165	313	11	BL-25-5	1397	240	549	215
R4i	467	165	313	18	Diode supply modules (DSU)				
R6i	467	220	456	38	D6D	815	170	408	37
R8i	1397	240	583	125	D7D	1054	170	417	73
LCL-line filter for IGBT supply unit (ISU)					D8D	1397	240	582	173
WFU-01	315	213	218	11	D7T	1178	170	417	80
WFU-02	315	213	218	11	D8T	1397	240	585	180
WFU-11	386	288	256	34					
WFU-21	406	318	299	45					
WFU-22	406	318	299	51					
ALCL-05-5	845	378	305	100					
BLCL-13-5	1397	240	505	181					
BLCL-15-5	1355	240	505	224					
BLCL-24-5	1397	240	581	320					
BLCL-25-5	1397	240	581	324					

Ratings, types and voltages Inverter modules

Inverter modules (INU), ACS880-104

$U_N = 690$ V (range 525 to 690 V). The power ratings are valid at nominal voltage 690 V (4 to 3200 kW).

Nominal ratings			Light-overload use		Heavy-duty use		Noise level	Heat dissipation	Air flow	Type designation	Frame size
I_N A (AC)	I_{max} A (AC)	P_N kW	I_{Ld} A	P_{Ld} kW	I_{Hd} A	P_{Hd} kW	dB(A)	kW	m ³ /h		
7.3	9.5	5.5	6.9	5.5	5.6	4	62	0.22	280	ACS880-104-007A3-7	R5i
9.8	12.7	7.5	9.3	7.5	7.3	5.5	62	0.28	280	ACS880-104-009A8-7	R5i
14.2	18.5	11	13.5	11	9.8	7.5	62	0.40	280	ACS880-104-014A2-7	R5i
18	23.4	15	17.1	15	14.2	11	62	0.49	280	ACS880-104-0018A-7	R5i
22	29	18.5	20.9	18.5	18	15	62	0.58	280	ACS880-104-0022A-7	R5i
27	35	22	25.7	22	22	18.5	62	0.66	280	ACS880-104-0027A-7	R5i
35	46	30	33.3	30	27	22	62	0.86	280	ACS880-104-0035A-7	R5i
42	55	37	39.9	37	35	30	62	1.00	280	ACS880-104-0042A-7	R5i
52	68	45	49.4	45	42	37	62	1.12	280	ACS880-104-0052A-7	R5i
62	81	55	60	55	46	45	71	0.8	650	ACS880-104-0062A-7	R6i
82	107	75	79	75	61	55	71	1.1	650	ACS880-104-0082A-7	R6i
99	129	90	95	90	74	75	71	1.3	650	ACS880-104-0100A-7	R6i
125	163	110	120	110	94	75	71	1.5	650	ACS880-104-0130A-7	R6i
144	187	132	138	132	108	90	71	1.8	650	ACS880-104-0140A-7	R6i
192	250	160	184	160	144	132	71	2.5	650	ACS880-104-0190A-7	R6i
217	282	200	208	200	162	160	72	2.8	940	ACS880-104-0220A-7	R7i
270	351	250	259	250	202	200	72	3.3	940	ACS880-104-0270A-7	R7i
340	510	315	326	250	254	200	72	5.2	1300	ACS880-104-0340A-7	R8i
410	620	400	394	355	307	250	72	6.1	1300	ACS880-104-0410A-7	R8i
530	800	500	509	450	396	355	72	7.9	1300	ACS880-104-0530A-7	R8i
600	900	560	576	560	449	400	72	9	1300	ACS880-104-0600A-7	R8i
800	1200	800	768	710	598	560	74	12	2600	ACS880-104-0800A-7	2xR8i
1030	1550	1000	989	900	770	710	74	15	2600	ACS880-104-1030A-7	2xR8i
1170	1760	1100	1123	1000	875	800	74	18	2600	ACS880-104-1170A-7	2xR8i
1540	2310	1400	1478	1400	1152	1100	76	23	3900	ACS880-104-1540A-7	3xR8i
1740	2610	1600	1670	1600	1302	1200	76	26	3900	ACS880-104-1740A-7	3xR8i
2300	3450	2000	2208	2000	1720	1600	76	35	5200	ACS880-104-2300A-7	4xR8i
2860	4290	2800	2746	2400	2139	2000	77	43	6500	ACS880-104-2860A-7	5xR8i
3420	5130	3200	3283	3200	2558	2400	78	52	7800	ACS880-104-3420A-7	6xR8i

Dimensions

Frame size	Height (mm)	Width (mm)	Depth (mm)	Weight (kg)
R5i	596	203	240	14
R6i	890	170	456	38
R7i	890	170	456	39
R8i	1397	240	583	125

With module covers (R5i)

Nominal ratings

I_N	Rated current available continuously without overloadability at 40 °C.
S_N	Nominal apparent power.
P_N	Power in no-overload use.
I_{max}	Maximum output current. Available for 10 seconds at start, otherwise as long as allowed by drive temperature.

Light-overload use

I_{Ld}	Continuous current allowing 110% I_{Ld} for 1 min/5 min at 40 °C.
P_{Ld}	Power in light-overload use.

Heavy-duty use

I_{Hd}	Continuous current allowing 150% I_{Hd} for 1 min/5 min at 40 °C.
P_{Hd}	Power in heavy-duty use.

The ratings apply at 40 °C ambient temperature. At higher temperatures (up to 50 °C) the derating is 1%/1 °C.

¹⁾ +A018 Half-controlled diode bridge
+A004 12-pulse DSU

Ratings, types and voltages Supply units

IGBT supply modules (ISU), ACS880-204

$U_N = 690$ V (range 525 to 690 V). The power ratings are valid at nominal voltage 690 V (366 to 3679 kVA).

Nominal ratings				No-over-load use	Light-overload use		Heavy-duty use		Noise level	Heat dissipation	Air flow	Type designation	Frame size
I_N A (AC)	I_N A (DC)	I_{max} A (DC)	S_N kVA	P_N kW (DC)	I_{Ld} A (DC)	P_{Ld} kW (DC)	I_{Hd} A (DC)	P_{Hd} kW (DC)	dB(A)	kW	m ³ /h		
306	371	557	366	362	356	348	278	271	72	11.8	2200	ACS880-204-0310A-7	R8i+BLCL-13-7
369	447	671	441	437	430	419	335	327	72	13.5	2200	ACS880-204-0370A-7	R8i+BLCL-13-7
540	655	982	645	639	629	613	490	478	72	17.6	2200	ACS880-204-0540A-7	R8i+BLCL-15-7
720	873	1309	860	852	838	818	653	637	74	23.2	4100	ACS880-204-0720A-7	2xR8i+BLCL-24-7
1053	1277	1915	1258	1246	1226	1196	955	932	74	31.7	4100	ACS880-204-1050A-7	2xR8i+BLCL-25-7
1566	1899	2848	1872	1853	1823	1779	1420	1386	76	49.6	6900	ACS880-204-1570A-7	3xR8i+2xBLCL-24-7
2070	2510	3765	2474	2449	2409	2351	1877	1832	76	63	8200	ACS880-204-2070A-7	4xR8i+2xBLCL-25-7
3078	3732	5598	3679	3642	3583	3496	2792	2724	78	94.4	12300	ACS880-204-3080A-7	6xR8i+3xBLCL-25-7

Regenerative rectifier units (RRU), ACS880-904

$U_N = 690$ V (range 525 to 690 V). The power ratings are valid at nominal voltage 690 V (717 to 4135 kVA).

Nominal ratings				No-over-load use	Light-overload use		Heavy-duty use		Noise level	Heat dissipation	Air flow	Type designation ¹⁾	Frame size
I_N A (AC)	I_N A (DC)	I_{max} A (DC)	S_N kVA	P_N kW (DC)	I_{Ld} A (DC)	P_{Ld} kW (DC)	I_{Hd} A (DC)	P_{Hd} kW (DC)	dB(A)	kW	m ³ /h		
600	727	1102	717	678	698	651	544	507	72	9.8	2200	ACS880-904-0600A-7	1xR8i + BL-15-7
900	1091	1653	1076	1016	1048	976	816	760	72	14.3	2200	ACS880-904-0900A-7	1xR8i + BL-15-7
1180	1431	2168	1410	1333	1374	1279	1070	997	74	18.5	4100	ACS880-904-1180A-7	2xR8i + BL-25-7
1770	2146	3252	2115	1999	2060	1919	1605	1495	74	28.1	4100	ACS880-904-1770A-7	2xR8i + BL-25-7
2310	2801	4244	2761	2609	2689	2505	2095	1952	76	37.1	8200	ACS880-904-2310A-7	4xR8i + 2xBL-25-7
3460	4195	6356	4135	3908	4027	3752	3138	2923	76	56.2	8200	ACS880-904-3460A-7	4xR8i + 2xBL-25-7

Diode supply modules (DSU), ACS880-304

$U_N = 690$ V (range 525 to 690 V). The power ratings are valid at nominal voltage 690 V (683 to 5445 kVA).

Nominal ratings				No-over-load use	Light-overload use		Heavy-duty use		Noise level	Heat dissipation	Air flow	Type designation ¹⁾	Frame size
I_N A (AC)	I_N A (DC)	I_{max} A (DC)	S_N kVA	P_N kW (DC)	I_{Ld} A (DC)	P_{Ld} kW (DC)	I_{Hd} A (DC)	P_{Hd} kW (DC)	dB(A)	kW	m ³ /h		
6-pulse diode													
572	700	980	683	652	672	626	524	488	72	5	1300	ACS880-304-0570A-7+A018	D8T
816	1000	1400	976	932	960	894	748	697	72	6	1300	ACS880-304-0820A-7+A018	D8T
1063	1302	1823	1271	1213	1250	1164	974	907	74	9	2600	ACS880-304-1060A-7+A018	2xD8T
1519	1860	2604	1815	1733	1786	1663	1391	1296	74	13	2600	ACS880-304-1520A-7+A018	2xD8T
2278	2790	3906	2723	2599	2678	2495	2087	1944	76	19	3900	ACS880-304-2280A-7+A018	3xD8T
3037	3720	5208	3630	3465	3571	3327	2783	2592	76	26	5200	ACS880-304-3040A-7+A018	4xD8T
3797	4650	6510	4538	4331	4464	4158	3478	3240	77	32	6500	ACS880-304-3800A-7+A018	5xD8T
4556	5580	7812	5445	5198	5357	4990	4174	3888	78	38	7800	ACS880-304-4560A-7+A018	6xD8T
12-pulse diode													
759	930	1302	908	898	893	862	696	672	74	8	1800	ACS880-304-0760A-7+A004+A018	2xD7T
1063	1302	1823	1271	1258	1250	1207	974	941	74	9	2600	ACS880-304-1060A-7+A004+A018	2xD8T
1519	1860	2604	1815	1797	1786	1725	1391	1344	74	13	2600	ACS880-304-1520A-7+A004+A018	2xD8T
2126	2604	3646	2541	2515	2500	2415	1948	1882	76	18	5200	ACS880-304-2130A-7+A004+A018	4xD8T
3037	3720	5208	3630	3594	3571	3450	2783	2688	76	26	5200	ACS880-304-3040A-7+A004+A018	4xD8T
4556	5580	7812	5445	5390	5357	5175	4174	4032	78	38	7800	ACS880-304-4560A-7+A004+A018	6xD8T

Dimensions

Frame size	Height (mm)	Width (mm)	Depth (mm)	Weight (kg)
IGBT supply unit (ISU)				
R1i	364	90	234	4
R2i	380	100	312	6
R3i	467	165	313	11
R4i	467	165	313	18
R6i	900	170	456	38
R8i	1397	240	583	125
LCL-line filter for IGBT supply module (ISU)				
BLCL-13-7	1397	240	505	178
BLCL-15-7	1397	240	505	218
BLCL-24-7	1397	240	581	320
BLCL-25-7	1397	240	581	324
BLCL-24-7	1397	240	581	301
BLCL-25-7	1397	240	581	310

Frame size	Height (mm)	Width (mm)	Depth (mm)	Weight (kg)
Regenerative rectifier unit (RRU)				
R8i	1397	240	583	125
BL-15-7	1397	240	444	155
BL-25-7	1397	240	549	215
Diode supply modules (DSU)				
D7T	1178	170	417	80
D8T	1397	240	585	180

Standard interface and extensions for comprehensive connectivity

The ACS880 drive modules offer a wide range of standard interfaces. In addition the drive has three option slots that can be used for extensions including fieldbus adapter modules,

input/output extension modules, feedback modules and a safety functions module.

Control connections	Description
2 analog inputs (XAI)	Current input: -20 to 20 mA, R_{in} : 100 ohm Voltage input: -10 to 10 V, R_{in} > 200 kohm Resolution: 11 bit + sign bit
2 analog outputs (XAO)	0 to 20 mA, R_{load} < 500 ohm Frequency range: 0 to 300 Hz Resolution: 11 bit + sign bit
6 digital inputs (XDI)	Input type: NPN/PNP (DI1 to DI5), NPN (DI6) DI6 can alternatively be used as an input for a PTC thermistor.
Digital input interlock (DIIL)	Input type: NPN/PNP
2 digital inputs/outputs (XDIO)	As input: 24 V logic levels: "0" < 5 V, "1" > 15 V R_{in} : 2.0 kohm Filtering: 0.25 ms As output: Total output current from 24 V DC is limited to 200 mA Can be set as pulse train input and output
3 relay outputs (XRO1, XRO2, XRO3)	250 V AC/30 V DC, 2 A
Safe torque off (XSTO)	For the drive to start, both connections must be closed
Drive-to-drive link (XD2D)	Physical layer: EIA-485
Built-in Modbus Assistant control panel/PC tool connection	EIA-4z85 Connector: RJ-45



Control unit ZCU

Example of a typical drive modules input/output connection diagram. Variations may be possible (please see HW manual for more information).

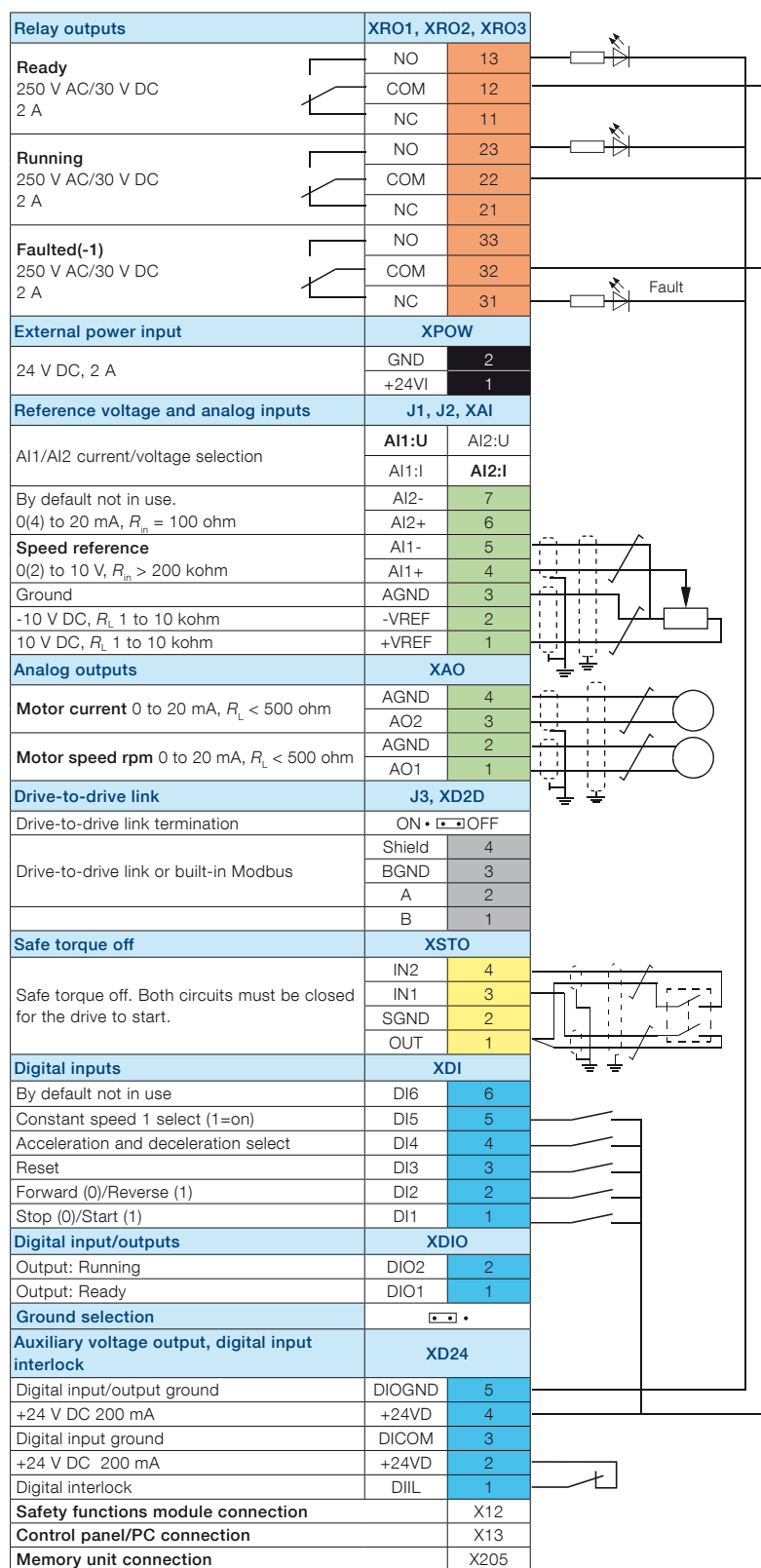

Standard software for scalable control and functionality

The same software, the primary control program, is used across the whole ACS880 series. Features such as built-in pre programmed application macros save time during configuration and drive commissioning. The application macros help set parameters for various functions including:

- Basic setup for input/output control and fieldbus control
- Hand/auto control for local and remote operation
- PID control for closed loop processes
- Sequential control for repetitive cycles
- Torque control
- Four user defined sets, for own parameter settings

Direct torque control (DTC)

The drives are equipped with direct torque control (DTC), ABB's signature motor control platform which supports motors such as induction motors, permanent magnet motors, servo motors and the new synchronous reluctance motor. It can also be used with sine filters. DTC helps control the motor from standstill to maximum torque and speed without the necessity of position sensors or encoders. DTC allows high overloadability, gives high starting torque and reduces stress on mechanics.

Energy efficiency information

The drives come with built-in energy efficiency information that helps the user fine-tune processes to ensure optimum energy use. The energy optimizer mode ensures the maximum torque per ampere, reducing energy drawn from the supply. The load profile feature collects drive values with three loggers: two amplitude loggers and one peak value logger. Calculators provide essential energy efficiency information: used and saved electrical energy, CO₂ reduction and money saved.

Additional software features include:

- Access levels
- Adaptive programming
- Automatic reset
- Automatic start
- Constant speeds
- Critical speeds and frequencies
- DC hold
- DC magnetizing
- Diagnostics
- Drive-to-drive link for master-follower control
- Flux braking
- Jogging
- Maintenance timer and counters
- Mechanical brake control
- Motor potentiometer
- Output phase order selection, switches rotation direction of the motor
- Oscillation damping
- Power loss ride-through
- Process PID control with trim function
- Programmable and pre-programmed protection functions
- Programmable inputs and outputs
- Scalar control with IR compensation
- Speed controller with auto tuning
- Startup assistants
- User adjustable load supervision/limitation
- User selectable acceleration and deceleration ramps
- Variable slope

Removable memory unit

The removable memory unit stores the standard software that includes user settings, parameter settings and motor data. Situated on the control unit, the memory unit can easily be removed for maintenance, update or replacement purposes. This common type of memory unit is used throughout the ACS880 series.



Application control programs



Our application control programs are developed by working closely with our customers over many years. This results in application programs that include the lessons learned from many customers, and that are designed to give you the flexibility to adapt the programs to your specific needs. These programs enhance application usability and lower energy consumption. They increase safe operation of the applications and reduce the need for a PLC. Other benefits include protection of machinery and optimization of application productivity. The programs also optimize time usage and lower operational costs.

The ACS880 application control programs come with adaptive programming features. This makes fine tuning of the ready-made application control program functionalities easy. Additionally, we understand that you may need to use different configurations in your process. That's why each of our control programs comes with the ability to configure up to four different configurations, or "user sets." The ACS880 drives offer integrated safety with safe torque off (STO) functionality as standard. The optional safety functions module comes with several safety functions including safe brake control (SBC).

Control program for cranes

This control program is dedicated for industrial, harbor, tower and marine deck cranes. It is possible to control crane movements in hoist and trolley and travel motions using the same software. The control program comes with integrated mechanical brake control to assure safe opening and closing of the mechanical disc or drum brakes. Standalone and master-follower functionality is supported along with synchro control of multimotors. The synchro control for common operation of the load functionality makes it possible to lift and lower loads, such as containers, in a smooth and balanced way during transportation. The load speed control function maximizes the hoist speed for the given load and ensures that there is sufficient motor torque in the field weakening area. This minimizes operation time and optimizes crane capacity. Fieldbus and conventional I/O control is supported. The antisway function is designed for indoor cranes to prevent unnecessary swaying of the load.

Control program for marine winches

The control program is designed for electrically driven deck machinery winches, such as anchor and mooring winches on different kinds of vessels. Anchoring and mooring on heavy vessels often involves low-speed, high-torque situations. Based on the application expertise gained with our customers over the years, we have developed drives that overcome the winching challenges and enable precise, dependable and smooth operation of new winch installations and retrofits of old winches.

The control program includes built-in anchor, hand-mooring and auto-mooring functions and parameter sets. The hand-mooring enables high-speed mode to quickly reel ropes in or out to achieve pre-tension in the ropes before switching over to auto-mooring. The operator can control operations from one of the four available control stands or using a wireless radio controller. All common control stand interfaces are supported.

The combination of direct torque control (DTC) and a winch control program eliminates the need for motor shaft encoders and gearbox load cell sensors, while the advanced mechanical brake control for the motor brake reduces stress on brake and gearbox.

Control program for winder

This control program makes sure that the unwinding and winding of a roll of web material, such as textile, plastic and paper is performed optimally. The control program observes the diameter of rolls and tension of the web material and makes sure that the drives controlling different parts of the winder are in sync. Based on the feedback from the dancer or tension measurement of the web, the speed or torque of the drive is adjusted appropriately. The result is a straightforward, cost-effective solution in web handling.

Application control programs



Control program for artificial oil lifting

This control program increases oil production for PCP (progressive cavity pumps), ESP (electro submersible pumps) or rod pumps. The program does not require any feedback encoder to work, which saves costs and increases reliability. The software also reduces stress on the complete pump system when optimizing fluid production. Backspin functionality is especially suitable for PCP and ESP pumps, which minimizes failure and makes oil pumping safe. Various startup ramp functions are also available. The sensorless control function (pump off control) helps to optimize oil pumping productivity by keeping the energy usage on a predetermined level. The efficiency of PCP pumps is significantly increased when using ACS880 drives together with SynRM motors.

Control program for centrifuge/decanter

This control program is designed to perform practical programmable sequences for conventional centrifuges. The program optimizes the separation of solids from the liquids in centrifuges, separators or decanter centrifuges. The speed difference of the decanter bowl and the scroll in the decanter centrifuge is controlled by the drive-to-drive functionality available in ACS880 drives.

Control program for cooling tower

This program is used in ACS880 drives to control high-torque and slow-speed synchronous RPM-AC permanent magnet motors in cooling tower applications. The control program is the basis for a drive-motor package where the cooling tower direct drive motor (CTDD) and the ACS880 drive is installed directly to the fans without any need for gearboxes, drive shafts or couplings. This provides high torque that is required for cooling tower applications without additional drivetrain components. The result is energy savings, reduced maintenance risk and costs, and direct-on-load startup current peaks. The control program for cooling tower is easy to commission and use. The ACS880 drives offer a streamlined parameter set that is focused on the typical cooling tower direct drive configurations where only necessary parameters are visible. Other cooling tower features in the drive include trickle current for keeping the motor warm and dry, a de-icing function to prevent ice build-up on the fan

blades and an anti-windmill function to prevent rotation of the fan during standby.

Spinning and traverse control program for ring frame textile machines

This control program offers precise control for over yarn production. It is designed to run spinning bobbins in ring frame textile machines. In order to achieve the best possible doffing, preset speed values based on elapsed time or length are given.

The traverse functionality is used in textile machines to guide the yarn into a yarn package.

Control program for tunnel fans in emergency situations

The emergency features of the override control program activate in case of an emergency, such as a fire in the tunnel. In this mode, most protections that would normally stop the drive are disabled. Ordinary start, stop and speed or frequency references are also disabled. Only the override reference is active.

Control program for chemical industry process control

The requirements imposed on PROFIBUS-DP communication by NAMUR NE 122 in the chemical industry can easily be met with the new PROFIBUS NAMUR control program, which is available for the complete ACS880 Industrial drive family. The PROFIBUS NAMUR control program allows communication between the drive and the process control system using the VIK-NAMUR profile to be easily and reliably set up with minimum effort.

In addition to PROFIBUS-DP communication according to NE122, ACS880 drives offer other features, such as support for NAMUR NE37 signals. ACS880 drives also conform to NAMUR NE38, as the DTC can operate with a sine filter. In addition, the ACS880 has integrated safety functions such as Safe Torque Off (STO), Safely-Limited Speed (SLS), an ATEX-certified safe disconnection function, and an integrated ATEX-certified thermistor protection module certified by TÜV Nord and VTT expert services Ltd. These features combined with ABB Ex drive and motor package certifications offer an excellent solution for the chemical industry.

Designed to control virtually any type of AC motor

Our ACS880 drives control virtually any type of AC motor including induction, permanent magnet, servo and synchronous reluctance motors. Motor control is optimized with direct torque control (DTC), ABB's premium motor control, built-in as a standard feature in our ACS880 drives. Our robust industrial drives ensure an energy efficient and reliable motor controller with significant cost savings for the user.

Direct torque control (DTC) for optimal control of motors

To ensure optimal control of an motor, our ACS880 drives offer direct torque control (DTC) as a built-in standard feature. In majority of applications, even with sine filters, the DTC reduces the need for an expensive speed feedback encoder. Direct torque control provides fast reaction to load changes in the motor shaft as well as reference changes on speed or torque made by the user. It makes the motor run optimally which lowers energy consumption and wear of the application.

ACS880 and induction motors form a reliable combination

Induction motors are used throughout the industry in several types of industry applications which demand robust and high enclosure motor and drive solutions. The ACS880 drives fit perfectly together with this type of motor, used in a wide range of industrial environments. The drives fit into environments that require high degree of protection and offer narrow facilities. ACS880 drives come with DTC as standard, which ensures high speed accuracy.

Because they are ATEX certified, our drives can be combined with ABB motors for explosive atmospheres.

ACS880 and permanent magnet motors for smooth operation

Permanent magnet technology is often used for improved motor characteristics such as energy efficiency, compactness and control performance. This technology is particularly well suited for low speed control industry applications, as they eliminate the need to use gear boxes. Actual characteristics between different permanent magnet motors can vary considerably. ACS880 drives with DTC can control ABB and most other permanent magnet motors without speed or rotor position sensors.

ACS880 and IE4 synchronous reluctance motors for a package with high efficiency

Combining the ACS880's control technology with our synchronous reluctance (SynRM) motors provides an IE4 motor and drive package that gives you great energy savings benefits. The key is in the rotor design. The synchronous reluctance rotor replaces the traditional induction rotor and requires no permanent magnets. ABB has tested our SynRM motor and drive packages and produced manufacturer's statements providing verified system (drive and motor) efficiency.

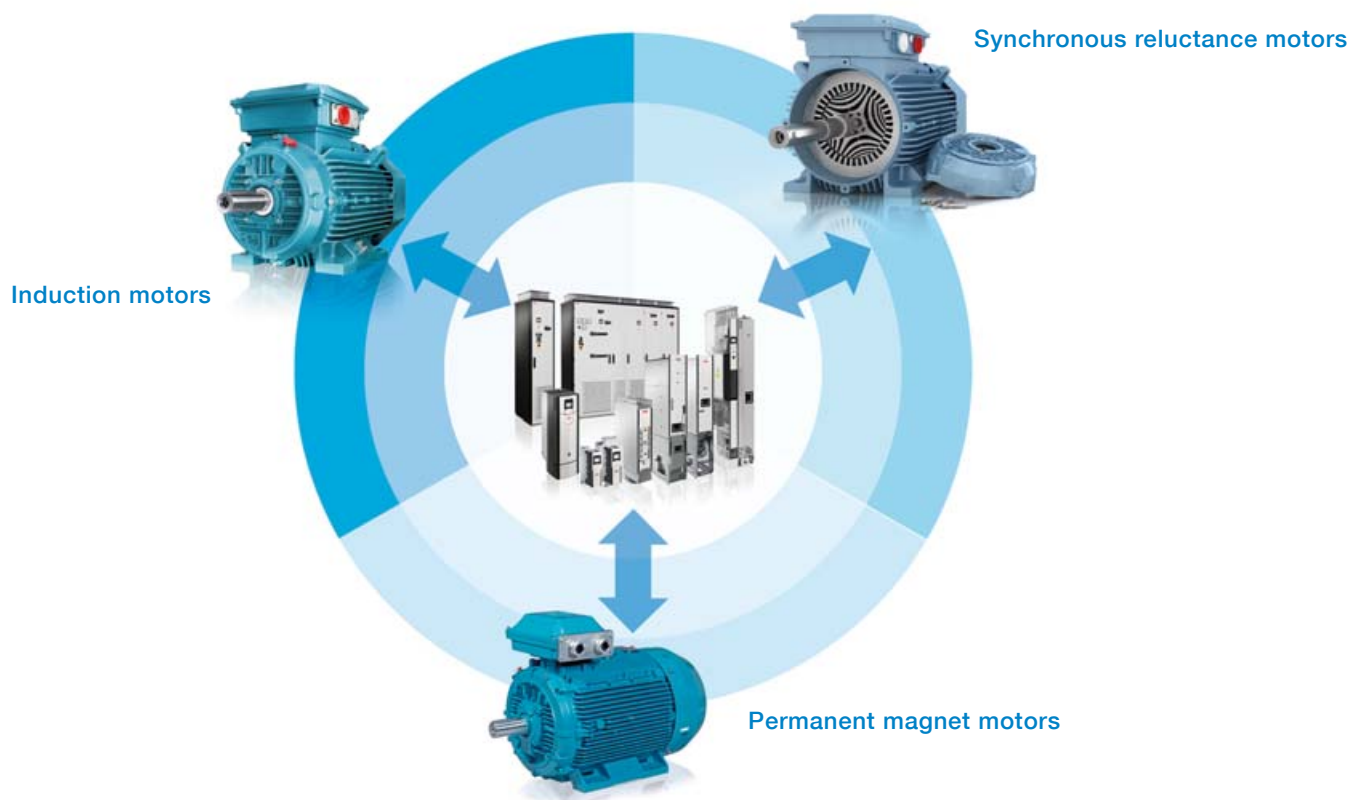

Intuitive human-machine interface

The assistant control panel features intuitive use and easy navigation. High resolution display enables visual guidance. The panel saves on commissioning and learning time by means of different assistants, making the drive simple to set up and use. Standard delivery includes Bluetooth panel which enables connection with Drivetune mobile app.

It is possible to organize parameters in different ways and store essential parameters for different configurations for any specialized application needed. The menus and messages can be customized for specific terminology so that each application can be set up and configured to its optimum performance. This makes the drive easier to use with information that is familiar to users. With the panel's text editor, users can also add information, customize text and label the drive. Powerful backup and restore functions are supported as well as different language versions. The help key provides context sensitive guidance. Faults or warnings can be resolved quickly since the help key provides troubleshooting instructions.

One control panel can be connected to several drives simultaneously using the panel network feature. The user can also select the drive to operate in the panel network. The PC tool can be easily connected to the drive through the USB connector on the control panel. There is also the assistant control panel mounting platform, DPMP-01 (IP54) and DPMP-02 (IP65) kit are available for cabinet door flush mounting.



PC tool for easy startup and maintenance

The Drive composer PC tool offers fast and harmonized setup, commissioning and monitoring for the whole drives portfolio. The free version of the tool provides startup and maintenance capabilities, while the professional version provides additional features such as custom parameter windows, control diagrams of the drive's configuration and safety settings.

The Drive composer tool is connected to the drive using an Ethernet connection or through the USB connection on the assistant control panel. Ethernet connection can use a shared network with Ethernet-based fieldbuses, thus reducing the amount of cabling. All drive information such as parameter loggers, faults, backups and event lists are gathered into a support diagnostics file with a single mouse click. This provides faster fault tracking, shortens downtime and minimizes operational and maintenance costs.

Drive composer pro

Drive composer pro provides basic functionality, including parameter settings, downloading and uploading files and search parameters. Advanced features such as graphical

control diagrams and various displays are also available. The control diagrams save users from browsing long lists of parameters and help to set the drive's logic quickly and easily. The tool has fast monitoring capabilities of multiple signals from several drives in a PC tool network. Full backup and restore functions are also included. Safety settings can be configured with Drive composer pro.



Integrated safety simplifies configuration

Integrated safety reduces the need for external safety components, simplifying configuration and reducing installation space. The safety functionality is a built-in feature of the ACS880, with safe torque off (STO) as standard. Additional safety functions can be commissioned with the optional and compact safety functions module. ACS880 drives offer encoderless safety. The drives' functional safety is designed in accordance with EN/IEC 61800-5-2 and complies with the requirements of the European Union Machinery Directive 2006/42/EC.

Safe torque off as standard

Safe torque off (STO) is used to prevent unexpected startup and in stopping-related functions, enabling safe machine maintenance and operation. With safe torque off activated, the drive will not provide a rotational field. This prevents the motor from generating torque on the shaft. This function corresponds to an uncontrolled stop in accordance with stop category 0 of EN 60204-1.

The safety functions modules

The easy to connect and configure safety functions module (FSO-12 and -21) offers a wide range of safety functions and a self diagnostic function that meets current safety requirements and standards, all in one compact module. Compared to using external safety components, the safety functions module comes with the supported functions seamlessly integrated with the drive functionality, reducing the implementation of safety function connections and configuration. Installation of the module results in less need for cabling and provides a cost-effective solution.

Commissioning and configuration of the safety functions module is done with the Drive composer pro PC tool. Larger safety systems can be built using PROFIsafe over Profinet connection between a safety PLC (such as AC500-S) and the ACS880 drive. The connection is achieved using the FENA-21 fieldbus adapter module and the safety functions module.

The safety functions module can also be ordered as a spare part kit and installed afterwards to the drive. The kit includes most common assembly accessories for ACS880 drives.

The module supports the following safety functions (which achieve up to SIL 3 or PL e (Cat. 3) safety level:

- **Safe stop 1 (SS1)** brings the machine to a stop (STO) using a monitored deceleration ramp. It is typically used in applications where the machinery motion needs to be brought to a stop (stop category 1) in a controlled way before switching over to the no-torque state.
- **Safe stop emergency (SSE)** can be configured to, upon request, either activate STO instantly (category 0 stop), or first initiate motor deceleration and then, once the motor has stopped, activate the STO (category 1 stop).
- **Safe brake control (SBC)** provides a safe output for controlling the motor's external (mechanical) brakes, together with STO.
- **Safely-limited speed (SLS)** ensures that the specified speed limit of the motor is not exceeded. This allows machine interaction to be performed at slow speed without stopping the drive. The safety function module comes with four individual SLS settings for speed monitoring. The safety functions module also provides a variable SLS function with PROFIsafe connection. This allows the user to change the speed limit of the SLS on the fly through a safety fieldbus communication.
- **Safe maximum speed (SMS)** monitors that the speed of the motor does not exceed the configured speed limit.
- **Prevention of unexpected startup (POUS)** ensures that the machine remains stopped when people are in a danger area.
- **Safe direction (SDI)** ensures that rotation is allowed only to the selected direction. Available only with FSO-21 and FSE-31.
- **Safe speed monitor (SSM)** provides information that speed is within the configured limits. Available only with FSO-21

Safe temperature monitoring can be done by using FPTC thermistor protection modules. These modules have SIL 2 or PL e safety level.

The safety functions module enables safety functions without an encoder. If the application requires a safe encoder feedback it can be established with the safety certified pulse encoder interface module FSE-31. The module provides safe encoder data to the safety functions module and can simultaneously be used as a feedback device for the drive.

Safety functions module

Option	Ordering code
FSO-12	+Q973
FSO-21+FSE-31	+Q972+L521
FPTC-01	+L536
FPTC-02 ¹⁾	+L537

¹⁾ ATEX certified



ACS880 drive with FSO-12



ACS880 cabinet-built drive with FSO-12

Drive application programming based on IEC standard 61131-3

Automation Builder, ABB's new software suite for automation engineering, makes programming of industry devices such as drives, PLC's, robots and human machine interfaces (HMI) easy using one integrated engineering suite. The Automation Builder is used both for engineering individual industry devices and for putting together entire automation projects. It is based on a widely used software environment that fulfills many different requirements of industrial automation projects, according to the IEC standard 61131-3. As a single tool, the Automation Builder reduces time typically needed for system configuration and programming. It also reduces the need for installing and maintaining separate programs simultaneously. Automation Builder enables the possibility to do online diagnostic checking of multiple tasks performed by different industrial devices such as ACS880 drives.

Drive application programming

Automation Builder makes it possible for system integrators and machine builders to integrate their desired functionality and know-how directly into ACS880 drives. This is possible as ACS880 drives come with programming capability embedded inside the drive. Designing an application program in the drive makes the end user application run more efficiently, even without a separate programmable controller. It also brings higher end-product quality and requires less need for installation space and wiring.

Automation Builder lets you extend the standard functionality of parameter functions for ACS880 drives. This makes the ACS880 drives very flexible to meet exact requirements set for end user applications. The library management functionality in Automation Builder shortens engineering time as reuse of existing program code is possible. Additional features include the ability to select and use one of five different programming languages, effective program debugging and user password protection.

Integrated engineering suite for operating several industry components together

Using the Drive manager tool embedded in Automation Builder together with ABB's AC500 PLC gives the user online connection to all drives in a fieldbus network. This speeds up commissioning and makes diagnostic of the entire automation system easy. Automation Builder saves all the configuration data of industry devices, including drive parameter settings, and program code to the same project archive. This makes engineering work more consistent and manageable.

Drive application programmability

Option	Option code
License key	+N8010

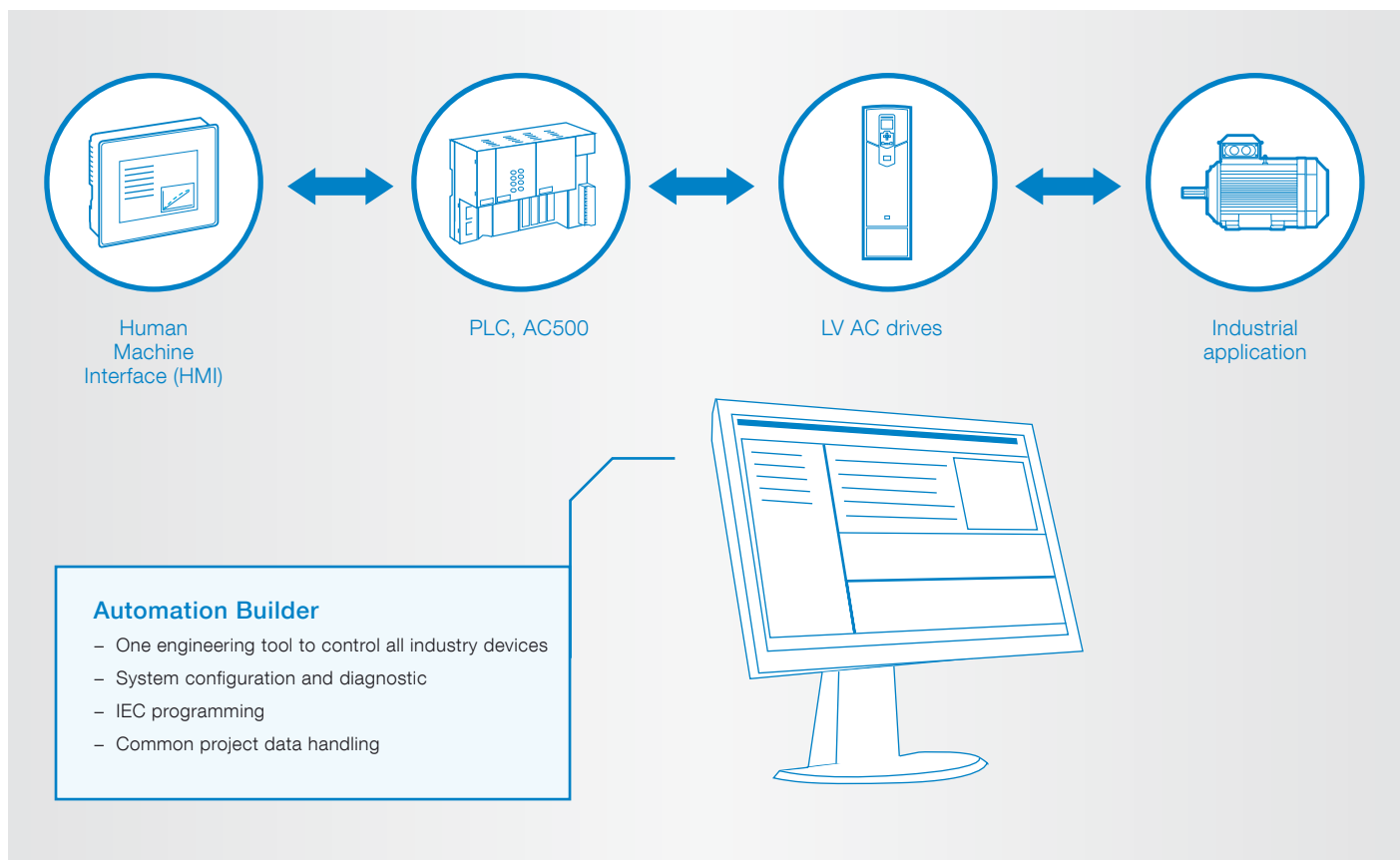

Flexible connectivity to automation networks

Our fieldbus adapter modules enable communication between drives, systems, devices and software. Our industrial drives are compatible with a wide range of fieldbus protocols.

The plug-in fieldbus adapter module can easily be mounted inside the drive. Other benefits include reduced wiring costs when compared with traditional input/output connections. Fieldbus systems are also less complex than conventional systems, resulting in less overall maintenance.

Multiple fieldbus connections for flexible control

ACS880 supports two fieldbus connections simultaneously. The user has flexibility of choice for control modes, and the possibility for redundant fieldbus adapters using the same protocol.

Redundant fieldbus communication

ACS880 supports Ethernet ring topology providing high network availability. Also switch over between physical networks is possible.

Drive monitoring

A set of drive parameters and/or actual signals, such as torque, speed, current, etc., can be selected for cyclic data transfer, providing fast data access.

Drive diagnostics

Accurate and reliable diagnostic information can be obtained through the alarm, limit and fault words.



Drive parameter handling

The Ethernet fieldbus adapter module allows users to build an Ethernet network for drive monitoring and diagnostic and parameter handling purposes.

Cabling

Substituting the large amount of conventional drive control cabling and wiring with a single cable reduces costs and increases system reliability and flexibility.

Design

The use of fieldbus control reduces engineering time at installation due to the modular structure of the hardware and software and the simplicity of the connections to the drives.

Commissioning and assembly

The modular machine configuration allows pre-commissioning of single machine sections and provides easy and fast assembly of the complete installation.

Universal communication with ABB fieldbus adapters

The ACS880 supports the following fieldbus protocols:

Fieldbus adapter modules

Option	Option code	Fieldbus protocol
FPBA-01	+K454	PROFIBUS DP, DPV0/DPV1
FCAN-01	+K457	CANopen®
FDNA-01	+K451	DeviceNet™
FENA-11	+K473	1 port EtherNet/IP™, Modbus TCP, PROFINET IO, PROFIsafe ¹⁾
FENA-21	+K475	2 port EtherNet/IP™, Modbus TCP, PROFINET IO, PROFIsafe ¹⁾
FECA-01	+K469	EtherCAT®
FSCA-01	+K458	Modbus RTU
FEPL-02	+K470	POWERLINK
FCNA-01	+K462	ControlNet™

¹⁾ For the PROFIsafe to work PROFINET fieldbus adapter module (FENA-21) and the safety functions module (FSO-12/-21) are required.



Input/output extension modules for increased connectivity

Standard input and output can be extended by using optional analog and digital input/output extension modules. The modules are easily installed in the extension slots located on the control unit.

Analog and digital input/output extension modules

Option	Option code	Connections
FIO-01	+L501	4×DI/O, 2×RO
FIO-11	+L500	3×AI (mA/V), 1×AO (mA), 2×DI/O
FAIO-01	+L525	2×AI (mA/V), 2×AO (mA)

Speed feedback interfaces for precise process control

ACS880 drives can be connected to various feedback devices, such as HTL pulse encoder, TTL pulse encoder, absolute encoder and resolver. The optional feedback module is installed in the option slot on the drive. It is possible to use two feedback modules at the same time, either of the same type or different type.

Feedback interface modules

Option	Option code	Connections
FEN-01	+L517	2 inputs (TTL pulse encoder), 1 output
FEN-11	+L518	2 inputs (SinCos absolute, TTL pulse encoder), 1 output
FEN-21	+L516	2 inputs (Resolver, TTL pulse encoder), 1 output
FEN-31	+L502	1 input (HTL pulse encoder), 1 output

I/O option extension adapter

For additional I/O option slots the FEA-03 is suitable for this use. An analog and digital input/output extension and speed feedback interface can be installed on the FEA-03. Two extension modules can be installed on each I/O extension slot. The connection to the control unit is via a fiber optic link and the adapter can be mounted on a DIN rail (35 x 7.5 mm).

I/O extension adapter

Option	Option code	Connections
FEA-03	+L515	2×F-type option extension slots

DDCS communication option modules

The FDCO-0X (used in the ZCU control unit) and RDCO-0X (used in the BCU control unit) optical DDCS communication options are add-on modules on the ACS880 industrial drives control board. The modules include connectors for two fiber optic DDCS channels. The FDCO-0X modules make it possible to perform master-follower and AC800 M communication.

Option	Option code	Connections
FDCO-01	+L503	Optical DDCS (10 Mbd/10 Mbd)
FDCO-02	+L508	Optical DDCS (5 Mbd/10 Mbd)
RDCO-04	+L509	Optical DDCS (10 Mbd/10 Mbd/10 Mbd/10 Mbd)

Remote monitoring access worldwide

The remote monitoring tool, NETA-21, gives easy access to the drive via the Internet or local Ethernet network. NETA-21 comes with a built-in web server. Being compatible with standard web browsers, it ensures easy access to a web-based user interface. Through the interface the user can configure drive parameters, monitor drive log data, and follow up load levels, run time, energy consumption, I/O data and bearing temperature of the motor connected to the drive.

The user can access the remote monitoring tool web page using 3G modem from anywhere with a standard PC, tablet or a mobile phone. The remote monitoring tool helps to reduce cost when personnel are able to monitor or perform maintenance for unmanned or manned applications in a range of industries. It is also very useful when more than one user wants to access the drive from several locations.

Enhanced monitoring functions

The remote monitoring tool supports process and drive data logging. Values of process variables or drives actual

values can be logged to NETA-21's SD memory card which is situated in the remote monitoring tool or sent forward to a centralized database. NETA-21 does not need an external database as the remote monitoring tool is able to store valuable data of the drive during its entire lifetime.

Unmanned monitoring of processes or devices is ensured by the built-in alarm functions that notify maintenance personnel if a safety level is reached. Alarm history with true time stamps are stored internally to the memory card as well as technical data, which is provided by the drive for troubleshooting purposes. True time stamps are also used with drives that do not have a real time clock as standard for ensuring events of all connected drives.



NETA-21

EMC – electromagnetic compatibility

EMC standards

The EMC product standard (EN 61800-3 (2004)) covers the specific EMC requirements stated for drives (tested with motor and cable) within the EU. EMC standards such as EN 55011 or EN 61000-6-3/4 are applicable to industrial and domestic equipment and systems including components inside the drive. Drive units complying with the requirements of EN 61800-3 are compliant with comparable categories in EN 55011 and EN 61000-6-3/4, but not necessarily vice versa. EN 55011 and EN 61000-6-3/4 do not specify cable length or require a motor to be connected as a load. The emission limits are comparable to EMC standards according to the table below.

1st environment versus 2nd environment

1st environment includes domestic premises. It also includes establishments directly connected without an intermediate transformer to a low voltage power supply network that supplies buildings used for domestic purposes.

2nd environment includes all establishments other than those directly connected to a low voltage power supply network that supplies buildings used for domestic purposes.

EMC standards

EMC according to EN 61800-3 (2004) product standard	EN 61800-3 product standard	EN 55011, product family standard for industrial, scientific and medical (ISM) equipment	EN 61000-6-4, generic emission standard for industrial environments	EN 61000-6-3, generic emission standard for residential, commercial and light-industrial environment
1 st environment, restricted distribution	Category C2	Group 1, Class A	Applicable	Not applicable
2 nd environment, unrestricted distribution	Category C3	Group 2, Class A	Not applicable	Not applicable
2 nd environment, restricted distribution	Category C4	Not applicable	Not applicable	Not applicable

Selecting an EMC filter

The following table gives the correct filter selection.

Type	Voltage	Frame sizes	1 st environment, restricted distribution, C2, grounded network (TN) Option code	2 nd environment, C3, grounded network (TN) Option code	2 nd environment, C3, ungrounded network (IT) Option code	2 nd environment, C3, grounded/ ungrounded network (TN/IT) Option code
ACS880-01	380 to 500 V	R1 to R9	+E202	+E200	+E201 (R6 to R9 frame size)	–
ACS880-01	690 V	R5 to R9	–	+E200	+E201 (R7 to R9 frame size)	–
ACS880-04	380 to 690 V	R10, R11	+E202 (not for 690 V)	–	–	+E210
ACS880-04	380 to 690 V	nxD8T + nxR8i	Not for 690V. Only for 1xD8T ²⁾	–	–	As standard ¹⁾
ACS880-14	380 to 690 V	nxR8i	Not for 690V. Only for 1xR8i ²⁾	–	–	As standard ¹⁾
ACS880-34	380 to 690 V	nxR8i	Not for 690V. Only for 1xR8i ²⁾	–	–	As standard ¹⁾
ACS880-204	380 to 690 V	R1i-R4i, R6i, nxR8i	Not for 690V. Only for R6i, 1xR8i ²⁾	–	–	As standard ¹⁾
ACS880-304	380 to 690 V	DxD, nxDxT	Not for 690V. Only for 1xD8T ²⁾	–	–	As standard ¹⁾

¹⁾ For Category C3 no optional equipment is needed, but the drive must be installed according to the instructions given in the manuals.

²⁾ For Category C2 optional equipment is needed, and the drive must be installed according to the instructions given in the manuals.

Sine filters, ACS880-01

Together with a sine filter, ACS880 drives offer smooth motor operation in both DTC and scalar modes. The sine filter suppresses high frequency components of the motors output voltage, creating almost a sinusoidal voltage wave form for the motor. The filter offers optimized LC design that takes into account switching frequency, voltage drop and filtering characteristics.

The ACS880 inverter and sine filter solution can be used together with a variety of requirements for products and components:

- For motors which don't have adequate insulation for the drives duty
- Where the total motor cable length is long as a result of a number of parallel motors
- For step-up applications eg where medium voltage motor needs to be driven
- For submersible pumps with long motor cables eg in the oil industry
- When the motor noise needs to be reduced
- When there are industry specific requirements for peak voltage level and voltage rise time

I _N A	P _N kW	Noise level dB *	Heat dissipation W *	Type designation	Filter size	Degree of protection	Filter								Frame size
							Width IP00 mm	Width IP21 mm	Depth IP00 mm	Depth IP21 mm	Height IP00 mm	Height IP21 mm	Weight IP00 kg	Weight IP21 kg	
U_N = 400 V (range 380 to 415 V). The power ratings are valid at nominal voltage 400 V.															
2.3	0.8	72	60	ACS880-01-02A4-3	B84143V0004R229	IP00/IP21	235	384	95	152	200	246	5	14.4	R1
3.1	1.1	72	60	ACS880-01-03A3-3	B84143V0004R229	IP00/IP21	235	384	95	152	200	246	5	14.4	R1
3.8	1.5	72	60	ACS880-01-04A0-3	B84143V0004R229	IP00/IP21	235	384	95	152	200	246	5	14.4	R1
5.3	2.2	72	100	ACS880-01-05A6-3	B84143V0006R229	IP00/IP21	235	384	95	152	200	246	5	14.4	R1
7.2	3	72	90	ACS880-01-07A2-3	B84143V0011R229	IP00/IP21	235	384	110	152	200	246	7	14.4	R1
9.4	4	72	90	ACS880-01-09A4-3	B84143V0011R229	IP00/IP21	235	384	110	152	200	246	7	14.4	R1
12.1	5.5	72	80	ACS880-01-12A6-3	B84143V0016R229	IP00/IP21	275	420	122	200	235	290	12	24.4	R1
16	7.5	75	140	ACS880-01-017A-3	B84143V0025R229	IP00/IP21	355	500	120	200	285	360	20	36	R2
24	11	75	140	ACS880-01-025A-3	B84143V0025R229	IP00/IP21	355	500	120	200	285	360	20	36	R2
31	15	75	160	ACS880-01-032A-3	B84143V0033R229	IP00/IP21	355	500	120	200	285	360	24	36	R3
37	18.5	78	220	ACS880-01-038A-3	B84143V0050R229	IP00/IP21	400	650	140	350	360	460	41	90.3	R3
43	22	78	220	ACS880-01-045A-3	B84143V0050R229	IP00/IP21	400	650	140	350	360	460	41	90.3	R4
60	30	78	250	ACS880-01-061A-3	B84143V0066R229	IP00/IP21	400	650	147	350	360	460	43	90.3	R4
64	30	79	310	ACS880-01-072A-3	B84143V0075R229	IP00/IP21	400	650	173	350	360	460	62	90.3	R5
77	37	79	400	ACS880-01-087A-3	B84143V0095R229	IP00/IP21	440	700	164	350	500	580	70	132	R5
91	45	80	600	ACS880-01-105A-3	B84143V0130S230	IP00/IP21	560	850	300	480	420	500	110	192	R6
126	55	80	550	ACS880-01-145A-3	B84143V0162S229	IP00/IP21	500	730	300	400	380	430	112	129.9	R6
153	75	80	550	ACS880-01-169A-3	B84143V0162S229	IP00/IP21	500	730	300	400	380	430	112	129.9	R7
187	90	80	900	ACS880-01-206A-3	B84143V0230S229	IP00/IP21	570	850	285	480	430	500	120	192	R7
209	110	80	900	ACS880-01-246A-3	B84143V0230S229	IP00/IP21	570	850	285	480	430	500	120	192	R8
249	132	80	1570	ACS880-01-293A-3	B84143V0390S229	IP00/IP21	555	850	328	550	580	610	212	268.4	R8
297	160	80	1570	ACS880-01-363A-3	B84143V0390S229	IP00/IP21	555	850	328	550	580	610	212	268.4	R9
352	160	80	1570	ACS880-01-430A-3	B84143V0390S229	IP00/IP21	555	850	328	550	580	610	212	268.4	R9

U_N = 500 V (range 380 to 500 V). The power ratings are valid at nominal voltage 500 V.															
1.9	0.8	72	60	ACS880-01-02A1-5	B84143V0004R229	IP00/IP21	235	384	95	152	200	246	5	14.4	R1
2.8	1.1	72	60	ACS880-01-03A0-5	B84143V0004R229	IP00/IP21	235	384	95	152	200	246	5	14.4	R1
3.1	1.5	72	60	ACS880-01-03A4-5	B84143V0004R229	IP00/IP21	235	384	95	152	200	246	5	14.4	R1
4.4	2.2	72	100	ACS880-01-04A8-5	B84143V0006R229	IP00/IP21	235	384	95	152	200	246	5	14.4	R1
4.8	3	72	100	ACS880-01-05A2-5	B84143V0006R229	IP00/IP21	235	384	95	152	200	246	5	14.4	R1
7	4	72	90	ACS880-01-07A6-5	B84143V0011R229	IP00/IP21	235	384	110	152	200	246	7	14.4	R1
10.2	5.5	72	90	ACS880-01-11A0-5	B84143V0011R229	IP00/IP21	235	384	110	152	200	246	7	14.4	R1
13	7.5	70	80	ACS880-01-014A-5	B84143V0016R229	IP00/IP21	275	420	122	200	235	290	12	24.4	R2
20	11	75	140	ACS880-01-021A-5	B84143V0025R229	IP00/IP21	355	500	120	200	285	360	20	36	R2
25	15	75	160	ACS880-01-027A-5	B84143V0033R229	IP00/IP21	355	500	120	200	285	360	24	36	R3
32	18.5	78	220	ACS880-01-034A-5	B84143V0050R229	IP00/IP21	400	650	140	350	360	460	41	90.3	R3
35	22	78	220	ACS880-01-040A-5	B84143V0050R229	IP00/IP21	400	650	140	350	360	460	41	90.3	R4
49	30	78	250	ACS880-01-052A-5	B84143V0066R229	IP00/IP21	400	650	147	350	360	460	43	90.3	R4
60	37	78	250	ACS880-01-065A-5	B84143V0066R229	IP00/IP21	400	650	147	350	360	460	43	90.3	R5
62	37	78	310	ACS880-01-077A-5	B84143V0075R229	IP00/IP21	400	650	173	350	360	460	62	132	R5
80	55	80	630	ACS880-01-096A-5	B84143V0130S230	IP00/IP21	565	850	300	480	420	500	110	192	R6
104	55	80	630	ACS880-01-124A-5	B84143V0130S230	IP00/IP21	565	850	300	480	420	500	110	192	R6
140	90	80	550	ACS880-01-156A-5	B84143V0162S229	IP00/IP21	500	730	300	400	380	430	112	129.9	R7
162	110	80	550	ACS880-01-180A-5	B84143V0162S229	IP00/IP21	500	730	300	400	380	430	112	129.9	R7
205	132	80	900	ACS880-01-240A-5	B84143V0230S229	IP00/IP21	570	850	285	480	430	500	120	192	R8
221	132	80	900	ACS880-01-260A-5	B84143V0230S229	IP00/IP21	570	850	285	480	430	500	120	192	R8
289	200	80	1570	ACS880-01-361A-5	B84143V0390S229	IP00/IP21	555	850	328	550	580	610	212	268.4	R9
332	200	80	1570	ACS880-01-414A-5	B84143V0390S229	IP00/IP21	555	850	328	550	580	610	212	268.4	R9

Sine filters, ACS880-01

I_N	$P_N^{1)}$	Noise level	Heat dissipation	Type designation	Filter size	Degree of protection	Filter								Frame size
							Width IP00	Width IP21	Depth IP00	Depth IP21	Height IP00	Height IP21	Weight IP00	Weight IP21	
A	kW	dB ²⁾	W ²⁾				mm	mm	mm	mm	mm	mm	kg	kg	
$U_N = 690 \text{ V}$ (range 525 to 690 V). The power ratings are valid at nominal voltage 690 V.															
7.3	5.5	72	90	ACS880-01-07A3-7	B84143V0010R230	IP00/IP21	380	500	110	200	290	360	15	36	R5
9.3	7.5	72	90	ACS880-01-09A8-7	B84143V0010R230	IP00/IP21	380	500	110	200	290	360	15	36	R5
13.5	11	72	130	ACS880-01-14A2-7	B84143V0018R230	IP00/IP21	380	500	121	200	290	360	19	36	R5
17.1	15	72	130	ACS880-01-018A-7	B84143V0018R230	IP00/IP21	380	500	121	200	290	360	19	36	R5
21	18.5	72	160	ACS880-01-022A-7	B84143V0026R230	IP00/IP21	380	500	141	200	290	360	30	68	R5
25	22	72	160	ACS880-01-026A-7	B84143V0026R230	IP00/IP21	380	500	141	200	290	360	30	68	R5
33	30	75	250	ACS880-01-035A-7	B84143V0040R230	IP00/IP21	440	650	147	350	355	430	49	90.3	R5
40	37	75	250	ACS880-01-042A-7	B84143V0040R230	IP00/IP21	440	650	147	350	355	430	49	90.3	R5
48	45	78	290	ACS880-01-049A-7	B84143V0056R230	IP00/IP21	440	650	162	350	355	430	52	90.3	R5
56	55	78	290	ACS880-01-061A-7	B84143V0056R230	IP00/IP21	440	600	162	350	355	430	52	90.3	R6
78	75	79	610	ACS880-01-084A-7	B84143V0092R230	IP00/IP21	500	700	193	350	490	580	85	132	R6
92	90	79	610	ACS880-01-098A-7	B84143V0092R230	IP00/IP21	500	700	193	350	490	580	85	132	R7
112	110	80	630	ACS880-01-119A-7	B84143V0130S230	IP00/IP21	565	850	300	480	420	500	110	192	R7
112	110	80	630	ACS880-01-142A-7	B84143V0130S230	IP00/IP21	560	850	230	480	569	500	110	192	R8
138	132	80	930	ACS880-01-174A-7	B84143V0207S230	IP00/IP21	560	850	279	550	570	610	185	268.4	R8
161	132	80	930	ACS880-01-210A-7	B84143V0207S230	IP00/IP21	560	850	279	550	570	610	185	268.4	R9
208	200	80	930	ACS880-01-271A-7	B84143V0207S230	IP00/IP21	560	850	279	550	570	610	185	268.4	R9

Nominal ratings

I_N Rated current of the drive-filter combination available continuously without overload at 40 °C.

Typical ratings

P_N Typical motor power

Notes:

¹⁾ Please note that sine filters cause voltage drop thus reducing the available shaft power from the motor.

²⁾ Noise level is a combined value for the drive and the filter. Heat dissipation is a value for the filter.

For further information please contact your local ABB.

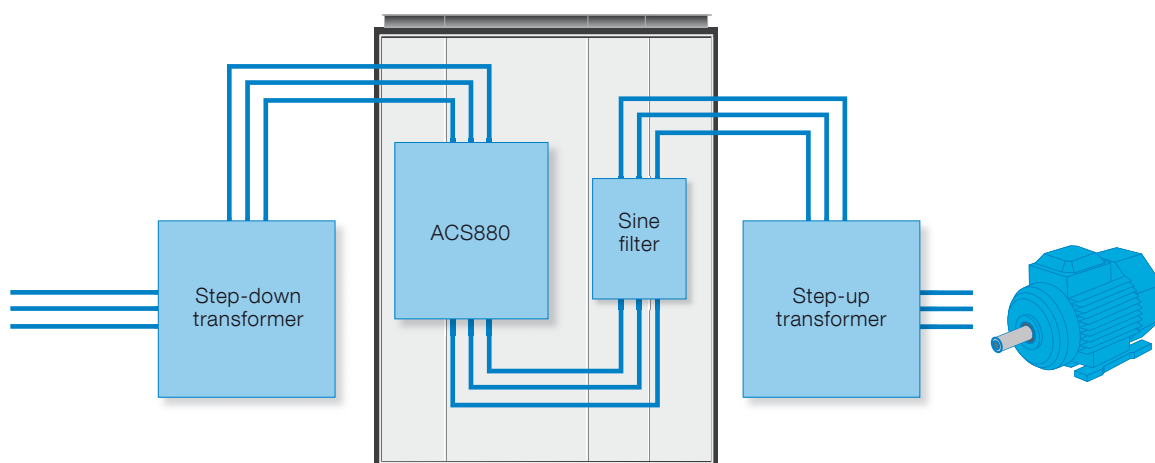

For step-up applications eg, where medium voltage motor needs to be driven

Sine filters, ACS880-04

I_N	P_N	Heat dissipation W	Type designation	Filter size	Degree of protection	Filter				Frame size
						Height mm	Width mm	Depth mm	Weight kg	
$U_N = 400\text{ V}$ (range 380 to 415 V). The power ratings are valid at nominal voltage 400 V.										
470	250	2020	ACS880-04-505A-3	NSIN900-6	IP00	2120	1000	600	690	R10
540	250	2020	ACS880-04-585A-3	NSIN900-6	IP00	2120	1000	600	690	R10
600	315	2020	ACS880-04-650A-3	NSIN900-6	IP00	2120	1000	600	690	R10
647	355	2020	ACS880-04-725A-3	NSIN900-6	IP00	2120	1000	600	690	R11
731	400	2020	ACS880-04-820A-3	NSIN900-6	IP00	2120	1000	600	690	R11
785	450	1800	ACS880-04-880A-3	NSIN900-6	IP00	2120	1000	600	690	R11
$U_N = 500\text{ V}$ (range 380 to 500 V). The power ratings are valid at nominal voltage 500 V.										
430	250	720	ACS880-04-460A-5	NSIN485-6	IP00	2120	1000	600	690	R10
470	315	2020	ACS880-04-503A-5	NSIN900-6	IP00	2120	1000	600	690	R10
514	355	2020	ACS880-04-583A-5	NSIN900-6	IP00	2120	1000	600	690	R10
560	400	2020	ACS880-04-635A-5	NSIN900-6	IP00	2120	1000	600	690	R10
637	450	2020	ACS880-04-715A-5	NSIN900-6	IP00	2120	1000	600	690	R11
730	500	2020	ACS880-04-820A-5	NSIN900-6	IP00	2120	1000	600	690	R11
730	500	2020	ACS880-04-880A-5	NSIN900-6	IP00	2120	1000	600	690	R11
$U_N = 690\text{ V}$ (range 525 to 690 V). The power ratings are valid at nominal voltage 690 V.										
330	315	720	ACS880-04-330A-7	NSIN485-6	IP00	2060	400	600	250	R10
340	315	720	ACS880-04-370A-7	NSIN485-6	IP00	2060	400	600	250	R10
360	355	720	ACS880-04-430A-7	NSIN485-6	IP00	2060	400	600	250	R10
*	*	720	ACS880-04-425A-7	NSIN485-6	IP00	2060	400	600	250	R11
*	*	720	ACS880-04-470A-7	NSIN900-6	IP00	2120	1000	600	690	R11
*	*	720	ACS880-04-522A-7	NSIN900-6	IP00	2120	1000	600	690	R11
530	500	2020	ACS880-04-590A-7	NSIN900-6	IP00	2120	1000	600	690	R11
550	560	2020	ACS880-04-650A-7	NSIN900-6	IP00	2120	1000	600	690	R11
550	630	2020	ACS880-04-721A-7	NSIN900-6	IP00	2120	1000	600	690	R11

* For further information please contact your local ABB

Note: Noise level is a combined value for the drive and the filter. Heat dissipation is a value for the filter.

Nominal ratings

I_N	Rated current of the drive-filter combination available continuously without overload at 40 °C.
P_N	Typical motor power

Brake options, ACS880-01

Brake chopper

The brake chopper is built-in as standard for the ACS880-01 frame sizes R1 to R4. For other ACS880-01 frames, a brake chopper is a selectable internal option. The air-cooled brake chopper for other single and multidrive module unit includes an NBRA brake chopper module or two parallel-connected NBRA brake chopper modules. The brake chopper handles the energy generated by a decelerating motor. The chopper connects the brake resistor to the intermediate DC circuit whenever the voltage in the circuit exceeds the limit defined by the control program. Energy consumption by the resistor losses lowers the voltage until the resistor can be disconnected.

Brake resistor

The brake resistors (JBR, SACE, SAFUR) are separately available for ACS880 drive modules. Resistors other than the standard option resistors may be used, provided that the specified resistance value is not decreased and that the heat dissipation capacity of the resistor is sufficient for the drive application.



NBRA659 brake chopper

ACS880-01 brakes

Braking power		Brake resistor(s)				Type designation	Frame size
P_{brcont} [kW]	R_{min} ohm	Type	R [Ohm]	E_r [kJ]	P_{rcont} [kW]		
0.75	65	JBR-03	80	40	0.14	ACS880-01-04A6-2	R1
1.1	65	JBR-03	80	40	0.14	ACS880-01-06A6-2	R1
1.5	65	JBR-03	80	40	0.14	ACS880-01-07A5-2	R1
2.2	65	JBR-03	80	40	0.14	ACS880-01-10A6-2	R1
4	18	SACE15RE22	22	420	2	ACS880-01-16A8-2	R2
5.5	18	SACE15RE22	22	420	2	ACS880-01-24A3-2	R2
7.5	13	SACE15RE13	13	435	2	ACS880-01-031A-2	R3
11	12	SACE15RE13	13	435	2	ACS880-01-046A-2	R4
11	12	SACE15RE13	13	435	2	ACS880-01-061A-2	R4
18.5	6	SAFUR90F575	8	1800	4.5	ACS880-01-075A-2+D150	R5
22	6	SAFUR90F575	8	1800	4.5	ACS880-01-087A-2+D150	R5
30	3.5	SAFUR125F500	4	3600	9	ACS880-01-115A-2+D150	R6
37	3.5	SAFUR125F500	4	3600	9	ACS880-01-145A-2+D150	R6
45	2.4	SAFUR200F500	2.7	5400	13.5	ACS880-01-170A-2+D150	R7
55	2.4	SAFUR200F500	2.7	5400	13.5	ACS880-01-206A-2+D150	R7
75	1.8	SAFUR200F500	2.7	5400	13.5	ACS880-01-274A-2+D150	R8

Braking power		Brake resistor(s)				Type designation	Frame size
P_{brcont} [kW]	R_{min} ohm	Type	R [Ohm]	E_r [kJ]	P_{rcont} [kW]		
0.75	78	JBR-03	80	40	0.14	ACS880-01-02A4-3	R1
1.1	78	JBR-03	80	40	0.14	ACS880-01-03A3-3	R1
1.5	78	JBR-03	80	40	0.14	ACS880-01-04A0-3	R1
2.2	78	JBR-03	80	40	0.14	ACS880-01-05A6-3	R1
3	78	JBR-03	80	40	0.14	ACS880-01-07A2-3	R1
4	78	JBR-03	80	40	0.14	ACS880-01-09A4-3	R1
5.5	78	JBR-03	80	40	0.14	ACS880-01-12A6-3	R1
7.5	39	SACE08RE44	44	210	1	ACS880-01-017A-3	R2
11	39	SACE08RE44	44	210	1	ACS880-01-025A-3	R2
15	19	SACE15RE22	22	420	2	ACS880-01-032A-3	R3
18.5	19	SACE15RE22	22	420	2	ACS880-01-038A-3	R3
22	13	SACE15RE13	13	435	2	ACS880-01-045A-3	R4
22	13	SACE15RE13	13	435	2	ACS880-01-061A-3	R4
37	8	SAFUR90F575	8	1800	4.5	ACS880-01-072A-3+D150	R5
45	8	SAFUR90F575	8	1800	4.5	ACS880-01-087A-3+D150	R5
55	5.4	SAFUR80F500	6	2400	6	ACS880-01-105A-3+D150	R6
75	5.4	SAFUR80F500	6	2400	6	ACS880-01-145A-3+D150	R6
90	3.3	SAFUR125F500	4	3600	9	ACS880-01-169A-3+D150	R7
110	3.3	SAFUR125F500	4	3600	9	ACS880-01-206A-3+D150	R7
132	2.3	SAFUR200F500	2.7	5400	13.5	ACS880-01-246A-3+D150	R8
132	2.3	SAFUR200F500	2.7	5400	13.5	ACS880-01-293A-3+D150	R8
160	2	SAFUR200F500	2.7	5400	13.5	ACS880-01-363A-3+D150	R9
160	2	SAFUR200F500	2.7	5400	13.5	ACS880-01-430A-3+D150	R9

All brake resistors are to be installed outside the converter module.
The SACE brake resistors are built-in to an IP21 metal housing.
The SAFUR brake resistors are built-in to an IP00 metal frame.

Brake options, ACS880-01

U _N = 500 V (range 380 to 500 V)							
Braking power		Brake resistor(s)				Type designation	Frame size
P _{brcont} [kW]	R _{min} ohm	Type	R [Ohm]	E _r [kJ]	P _{rcont} [kW]		
0.75	78	JBR-03	80	40	0.14	ACS880-01-02A1-5	R1
1.1	78	JBR-03	80	40	0.14	ACS880-01-03A0-5	R1
1.5	78	JBR-03	80	40	0.14	ACS880-01-03A4-5	R1
2.2	78	JBR-03	80	40	0.14	ACS880-01-04A8-5	R1
3	78	JBR-03	80	40	0.14	ACS880-01-05A2-5	R1
4	78	JBR-03	80	40	0.14	ACS880-01-07A6-5	R1
5.5	78	JBR-03	80	40	0.14	ACS880-01-11A0-5	R1
7.5	39	SACE08RE44	44	210	1	ACS880-01-014A-5	R2
11	39	SACE08RE44	44	210	1	ACS880-01-021A-5	R2
15	19	SACE15RE22	22	420	2	ACS880-01-027A-5	R3
18.5	19	SACE15RE22	22	420	2	ACS880-01-034A-5	R3
22	13	SACE15RE13	13	435	2	ACS880-01-040A-5	R4
22	13	SACE15RE13	13	435	2	ACS880-01-052A-5	R4
37	8	SAFUR90F575	8	1800	4.5	ACS880-01-065A-5+D150	R5
45	8	SAFUR90F575	8	1800	4.5	ACS880-01-077A-5+D150	R5
55	5.4	SAFUR80F500	6	2400	6	ACS880-01-096A-5+D150	R6
75	5.4	SAFUR80F500	6	2400	6	ACS880-01-124A-5+D150	R6
90	3.3	SAFUR125F500	4	3600	9	ACS880-01-156A-5+D150	R7
110	3.3	SAFUR125F500	4	3600	9	ACS880-01-180A-5+D150	R7
132	2.3	SAFUR200F500	2.7	5400	13.5	ACS880-01-240A-5+D150	R8
132	2.3	SAFUR200F500	2.7	5400	13.5	ACS880-01-260A-5+D150	R8
160	2.3	SAFUR200F500	2.7	5400	13.5	ACS880-01-361A-5+D150	R9
160	2.3	SAFUR200F500	2.7	5400	13.5	ACS880-01-414A-5+D150	R9

U _N = 690 V (range 525 to 690 V)							
Braking power		Brake resistor(s)				Type designation	Frame size
P _{brcont} [kW]	R _{min} ohm	Type	R [Ohm]	E _r [kJ]	P _{rcont} [kW]		
6	18	SACE08RE44	44	210	1	ACS880-01-07A3-7+D150	R5
8	18	SACE08RE44	44	210	1	ACS880-01-09A8-7+D150	R5
11	18	SACE08RE44	44	210	1	ACS880-01-14A2-7+D150	R5
17	18	SACE15RE22	22	420	2	ACS880-01-018A-7+D150	R5
23	18	SACE15RE22	22	420	2	ACS880-01-022A-7+D150	R5
28	18	SACE15RE22	22	420	2	ACS880-01-026A-7+D150	R5
33	18	SACE15RE22	22	420	2	ACS880-01-035A-7+D150	R5
45	18	SACE15RE22	22	420	2	ACS880-01-042A-7+D150	R5
45	18	SACE15RE22	22	420	2	ACS880-01-049A-7+D150	R5
55	13	SACE15RE13	13	435	2	ACS880-01-061A-7+D150	R6
65	13	SACE15RE13	13	435	2	ACS880-01-084A-7+D150	R6
90	8	SAFUR90F575	8	1800	4.5	ACS880-01-098A-7+D150	R7
110	8	SAFUR90F575	8	1800	4.5	ACS880-01-119A-7+D150	R7
132	6	SAFUR80F500	6	2400	6	ACS880-01-142A-7+D150	R8
160	6	SAFUR80F500	6	2400	6	ACS880-01-174A-7+D150	R8
200	4	SAFUR125F500	4	3600	9	ACS880-01-210A-7+D150	R9
200	4	SAFUR125F500	4	3600	9	ACS880-01-271A-7+D150	R9

All brake resistors are to be installed outside the converter module.
 The JBR brake resistors are built-in to an IP20 metal housing.
 The SACE brake resistors are built-in to an IP21 metal housing.
 The SAFUR brake resistors are built-in to an IP00 metal frame.

Maximum braking power of the ACS880 equipped with the standard chopper and the standard resistor

P _{brcont}	Continuous brake chopper power. The value applies to the minimum resistance value. With a higher resistance value the P _{brcont} may increase in some ACS880 units.
R	Resistance value for the listed resistor type.
R _{min}	Minimum allowable resistance value for the brake resistor.
E _r	Energy pulse that the resistor assembly will withstand (400 s duty cycle). This energy will heat the resistor element from 40 °C to the maximum allowable temperature.
P _{rcont}	Continuous power (heat) dissipation of the resistor when placed correctly. Energy E _r dissipates in 400 seconds.

Brake resistor	Height (mm)	Width (mm)	Depth (mm)	Weight (kg)
JBR-03	124	340	77	0.8
SACE08RE44	365	290	131	6.1
SACE15RE22	365	290	131	6.1
SACE15RE13	365	290	131	6.8
SAFUR80F500	600	300	345	14
SAFUR90F575	600	300	345	12
SAFUR125F500	1320	300	345	25
SAFUR200F500	1320	300	345	30

Brake options, ACS880-04, ACS880-X04

ACS880-04 brakes

$U_N = 400 \text{ V}$ (range 380 to 415 V)

Braking power		Brake resistor(s)				Type designation	Frame size
P_{brcont} [kW]	R_{min} ohm	Type	R [Ohm]	E_r [kJ]	P_{rcont} [kW]		
250	2.0	2xSAFUR125F500	2.00	7200	18	ACS880-04-505A-3	R10
315	1.3	2xSAFUR200F500	1.35	10800	27	ACS880-04-585A-3	R10
315	1.3	2xSAFUR200F500	1.35	10800	27	ACS880-04-650A-3	R10
400	0.7	3xSAFUR200F500	0.90	16200	40	ACS880-04-725A-3	R11
400	0.7	3xSAFUR200F500	0.90	16200	40	ACS880-04-810A-3	R11
400	0.7	3xSAFUR200F500	0.90	16200	40	ACS880-04-880A-3	R11

$U_N = 500 \text{ V}$ (range 380 to 500 V)

Braking power		Brake resistor(s)				Type designation	Frame size
P_{brcont} [kW]	R_{min} ohm	Type	R [Ohm]	E_r [kJ]	P_{rcont} [kW]		
250	2.0	2xSAFUR125F500	2.00	7200	18	ACS880-04-460A-5	R10
250	2.0	2xSAFUR125F500	2.00	7200	18	ACS880-04-503A-5	R10
315	1.3	2xSAFUR200F500	1.35	10800	27	ACS880-04-583A-5	R10
315	1.3	2xSAFUR200F500	1.35	10800	27	ACS880-04-635A-5	R10
400	0.7	3xSAFUR200F500	0.90	16200	40	ACS880-04-715A-5	R11
400	0.7	3xSAFUR200F500	0.90	16200	40	ACS880-04-820A-5	R11
400	0.7	3xSAFUR200F500	0.90	16200	40	ACS880-04-880A-5	R11

$U_N = 690 \text{ V}$ (range 525 to 690 V)

Braking power		Brake resistor(s)				Type designation	Frame size
P_{brcont} [kW]	R_{min} ohm	Type	R [Ohm]	E_r [kJ]	P_{rcont} [kW]		
285	2.2	SAFUR200F500	2.7	3600	13	ACS880-04-330A-7	R10
285	2.2	SAFUR200F500	2.7	3600	13	ACS880-04-370A-7	R10
285	2.2	SAFUR200F500	2.7	3600	13	ACS880-04-430A-7	R10
350	2.0	2xSAFUR125F500	2.0	7200	18	ACS880-04-425A-7	R11
350	2.0	2xSAFUR125F500	2.0	7200	18	ACS880-04-470A-7	R11
350	2.0	2xSAFUR125F500	2.0	7200	18	ACS880-04-522A-7	R11
400	1.8	2xSAFUR125F500	2.0	7200	18	ACS880-04-590A-7	R11
400	1.8	2xSAFUR125F500	2.0	7200	18	ACS880-04-650A-7	R11
400	1.8	2xSAFUR125F500	2.0	7200	18	ACS880-04-721A-7	R11

ACS880-604 brake chopper and resistor

$U_N = 400 \text{ V}$ (range 380 to 415 V)

Nominal ratings					Duty cycle (1min/5min)	Duty cycle (10s/60s)	Noise	Air flow	Type designation	Module type	Resistor type	
$P_{br,max}$ kW	R_{min} ohm	I_{max} A	I_{rms} A	$P_{cont.}$ kW	$P_{br.}$ kW	I_{rms} A	$P_{br.}$ kW	I_{rms} A	dB(A)	m ³ /h		

Brake chopper without brake resistor

230	1.7	384	109	70	230	355	230	355	64	660	ACS880-604-0210-3	NBRA658	-
353	1.2	545	149	96	303	468	353	545	64	660	ACS880-604-0320-3	NBRA659	-
706	2x1.2	1090	298	192	606	936	706	1090	67	1320	ACS880-604-0640-3	2xNBRA659	-
1058	0.4	1635	447	288	909	1404	1059	1635	68	1980	ACS880-604-0960-3	3xNBRA659	-
1411	0.3	2180	596	384	1212	1872	1412	2180	69	2640	ACS880-604-1280-3	4xNBRA659	-
1764	0.24	2725	745	480	1515	2340	1765	2725	70	3300	ACS880-604-1600-3	5xNBRA659	-
2117	0.2	3270	894	576	1818	2808	2118	3270	71	3960	ACS880-604-1920-3	6xNBRA659	-

Brake chopper with the resistor

230	1.7	384	65	42	130	200	224	346	66	2500	ACS880-604-0210-3+D151	NBRA658	1xSAFUR210F575
353	1.2	545	84	54	167	257	287	444	66	2500	ACS880-604-0320-3+D151	NBRA659	2xSAFUR180F460
706	2x1.2	1090	168	108	333	514	575	888	69	5000	ACS880-604-0640-3+D151	2xNBRA659	2x(2xSAFUR180F460)
1058	0.4	1635	252	162	500	771	862	1332	70	7500	ACS880-604-0960-3+D151	3xNBRA659	3x(2xSAFUR180F460)
1411	0.3	2180	336	216	667	1028	1150	1776	71	10000	ACS880-604-1280-3+D151	4xNBRA659	4x(2xSAFUR180F460)
1764	0.24	2725	420	270	833	1285	1437	2220	72	12500	ACS880-604-1600-3+D151	5xNBRA659	5x(2xSAFUR180F460)
2117	0.2	3270	504	324	1000	1542	1724	2664	73	15000	ACS880-604-1920-3+D151	6xNBRA659	6x(2xSAFUR180F460)

Brake options, ACS880-604

ACS880-604 brake chopper and resistor

Nominal ratings					Duty cycle (1min/5min)		Duty cycle (10s/60s)		Noise dB(A)	Air flow m³/h	Type designation	Module type	Resistor type
$P_{br,max}$ kW	R_{min} ohm	I_{max} A	I_{rms} A	$P_{cont.}$ kW	$P_{br.}$ kW	I_{rms} A	$P_{br.}$ kW	I_{rms} A					

Brake chopper without brake resistor

268	2.15	380	101	81	268	331	268	331	64	660	ACS880-604-0260-5	NBRA658	-
403	1.43	571	136	109	317	391	403	498	64	660	ACS880-604-0400-5	NBRA659	-
806	2x1.43	1142	272	218	634	782	806	996	67	1320	ACS880-604-0800-5	2xNBRA659	-
1208	0.45	1713	408	327	951	1173	1209	1494	68	1980	ACS880-604-1200-5	3xNBRA659	-
1611	0.3575	2284	544	436	1268	1564	1612	1992	69	2640	ACS880-604-1600-5	4xNBRA659	-
2014	0.286	2855	680	545	1585	1955	2015	2490	70	3300	ACS880-604-2000-5	5xNBRA659	-
2417	0.225	3426	816	654	1902	2346	2418	2988	71	3960	ACS880-604-2400-5	6xNBRA659	-

Brake chopper with the resistor

268	2	408	45	36	111	137	192	237	66	2500	ACS880-604-0260-5+D151	NBRA658	2xSAFUR125F500
403	1.35	605	67	54	167	206	287	355	66	2500	ACS880-604-0400-5+D151	NBRA659	2xSAFUR200F500
806	2x1.35	1210	134	108	333	412	575	710	69	5000	ACS880-604-0800-5+D151	2xNBRA659	2x(2xSAFUR200F500)
1208	0.45	1815	201	162	500	618	862	1065	70	7500	ACS880-604-1200-5+D151	3xNBRA659	3x(2xSAFUR200F500)
1611	0.3375	2420	268	216	667	824	1150	1420	71	10000	ACS880-604-1600-5+D151	4xNBRA659	4x(2xSAFUR200F500)
2014	0.27	3025	335	270	833	1030	1437	1775	72	12500	ACS880-604-2000-5+D151	5xNBRA659	5x(2xSAFUR200F500)
2417	0.225	3630	402	324	1000	1236	1724	2130	73	15000	ACS880-604-2400-5+D151	6xNBRA659	6x(2xSAFUR200F500)

$U_N = 690 V$ (range 525 to 690 V)

Nominal ratings					Duty cycle (1min/5min)		Duty cycle (10s/60s)		Noise dB(A)	Air flow m³/h	Type designation	Module type	Resistor type
$P_{br,max}$ kW	R_{min} ohm	I_{max} A	I_{rms} A	$P_{cont.}$ kW	$P_{br.}$ kW	I_{rms} A	$P_{br.}$ kW	I_{rms} A					

Brake chopper without brake resistor

404	2.72	414	107	119	298	267	404	361	64	660	ACS880-604-0400-7	NBRA669	-
807	1.36	828	214	238	596	534	808	722	64	660	ACS880-604-0800-7	2xNBRA669	-
1211	0.9066	1242	321	357	894	801	1212	1083	64	1320	ACS880-604-1200-7	3xNBRA669	-
1615	0.68	1656	428	476	1192	1068	1616	1444	64	1980	ACS880-604-1600-7	4xNBRA669	-
2019	0.544	2070	535	595	1490	1335	2020	1805	64	2640	ACS880-604-2000-7	5xNBRA669	-
2422	0.2383	2484	642	714	1788	1602	2424	2166	64	3300	ACS880-604-2400-7	6xNBRA669	-

Brake chopper with the resistor

404	1.35	835	97	54	167	149	287	257	66	2500	ACS880-604-0400-7+D151	NBRA669	2xSAFUR200F500
807	0.675	1670	194	108	333	298	575	514	69	5000	ACS880-604-0800-7+D151	2xNBRA669	2x(2xSAFUR200F500)
1211	0.45	2505	291	162	500	447	862	771	70	7500	ACS880-604-1200-7+D151	3xNBRA669	3x(2xSAFUR200F500)
1615	0.3375	3340	388	216	667	596	1150	1028	71	10000	ACS880-604-1600-7+D151	4xNBRA669	4x(2xSAFUR200F500)
2019	0.27	4175	485	270	833	745	1437	1285	72	12500	ACS880-604-2000-7+D151	5xNBRA669	5x(2xSAFUR200F500)
2422	0.225	5010	582	324	1000	894	1724	1542	73	15000	ACS880-604-2400-7+D151	6xNBRA669	6x(2xSAFUR200F500)

Heat loss of section with braking resistors is the same as braking power

Maximum braking power of the ACS880 equipped with the standard chopper and the standard resistor

$P_{br,max}$	Maximum short time braking power.
R	Recommended braking resistor resistance. Also nominal resistance of corresponding SAFUR resistor.
I_{max}	Maximum peak current per chopper during braking. Current is achieved with recommended resistor resistance.
$P_{cont.}$	Maximum continuous braking power. Continuous power (heat) dissipation of the resistor when placed correctly. Energy E_r dissipates in 400 seconds.
E_r	SAFUR resistor nominal braking capacity without forced cooling. Energy pulse that the resistor assembly will withstand (400 s duty cycle). This energy will heat the resistor element from 40 °C to the maximum allowable temperature.
$P_{br.}$	Braking power during corresponding cycle load: 1min/5min = 1 minute braking with power $P_{br.}$ and 4 minutes unload. 10 s/60 s = 10 second braking with power $P_{br.}$ and 50 seconds unload.
I_{rms}	Corresponding rms current per chopper during load cycle.
R_{min}	Minimum allowable resistance value for the brake resistor.

Dimensions

Choppers

Frame size	Height (mm)	Width (mm)	Depth (mm)	Weight (kg)
NBRA658	584	334	240	26
NBRA659	584	334	240	26
NBRA669	584	334	240	26

Resistors

Frame size	Height (mm)	Width (mm)	Depth (mm)	Weight (kg)
SAFUR180F460	1320	300	345	32
SAFUR125F500	1320	300	345	25
SAFUR200F500	1320	300	345	30
SAFUR210F575	1320	300	345	27

ACS880-604 3-phase dynamic brake units

ACS880-04 brakes

$U_N = 400 \text{ V}$ (range 380 to 415 V)

Resistor values		Ratings R_{min}							Ratings R_{max}						Type designation	Frame size	
		No-overload use				Cycle load (1min/5min)			No-overload use			Cycle load (1min/5min)					
R_{min} ohm	R_{max} ohm	I_{dc} A DC	I_{rms} A DC	P_{rcont} kW	I_{max} A DC	I_{dc} A DC	$I_{rms}-R_{min}$ A DC	$P_{br}-R_{min}$ kW	I_{dc} A DC	I_{rms} A DC	$P_{contmax}$ kW	I_{max} A DC	I_{dc} A DC	$I_{rms}-R_{max}$ A DC	$P_{br}-R_{max}$ kW		
1.7	2.1	781	310	500	370	999	351	640	781	282	500	312	827	291	530	ACS880-604-0500-3	R8i
1.2	1.4	1171	465	750	555	1499	527	960	1171	424	750	468	1241	436	800	ACS880-604-0750-3	R8i
1.7	2.1	1562	621	1000	740	1998	702	1290	1562	565	1000	625	1655	581	1060	ACS880-604-1000-3	2xR8i
1.2	1.4	2342	931	1510	1110	2997	1053	1930	2342	847	1510	937	2482	872	1600	ACS880-604-1510-3	2xR8i
1.2	1.4	3514	1396	2260	1665	4496	1580	2890	3514	1271	2260	1405	3723	1308	2400	ACS880-604-2260-3	3xR8i
1.2	1.4	4685	1862	3010	2220	5994	2106	3860	4685	1694	3010	1874	4964	1744	3190	ACS880-604-3010-3	4xR8i
1.2	1.4	5856	2327	3770	2775	7493	2633	4820	5856	2118	3770	2342	6205	2180	3990	ACS880-604-3770-3	5xR8i

$U_N = 500 \text{ V}$ (range 380 to 500 V)

Resistor values		Ratings R_{min}							Ratings R_{max}						Type designation	Frame size	
		No-overload use				Cycle load (1min/5min)			No-overload use			Cycle load (1min/5min)					
R_{min} ohm	R_{max} ohm	I_{dc} A DC	I_{rms} A DC	P_{rcont} kW	I_{max} A DC	I_{dc} A DC	$I_{rms}-R_{min}$ A DC	$P_{br}-R_{min}$ kW	I_{dc} A DC	I_{rms} A DC	$P_{contmax}$ kW	I_{max} A DC	I_{dc} A DC	$I_{rms}-R_{max}$ A DC	$P_{br}-R_{max}$ kW		
2.2	2.6	781	310	630	370	999	351	800	781	284	630	312	835	293	670	ACS880-604-0630-5	R8i
1.4	1.7	1171	465	940	555	1499	527	1210	1171	430	940	468	1277	449	1030	ACS880-604-0940-5	R8i
2.2	2.6	1562	621	1260	740	1998	702	1610	1562	568	1260	625	1671	587	1340	ACS880-604-1260-5	2xR8i
1.4	1.7	2342	931	1880	1110	2997	1053	2410	2342	860	1880	937	2555	898	2060	ACS880-604-1880-5	2xR8i
1.4	1.7	3514	1396	2830	1665	4496	1580	3620	3514	1289	2830	1405	3832	1347	3080	ACS880-604-2830-5	3xR8i
1.4	1.7	4685	1862	3770	2220	5994	2106	4820	4685	1719	3770	1874	5110	1795	4110	ACS880-604-3770-5	4xR8i
1.4	1.7	5856	2327	4710	2775	7493	2633	6030	5856	2149	4710	2342	6387	2244	5140	ACS880-604-4710-5	5xR8i

$U_N = 690 \text{ V}$ (range 525 to 690 V)

Resistor values		Ratings R_{min}							Ratings R_{max}						Type designation	Frame size	
		No-overload use				Cycle load (1min/5min)			No-overload use			Cycle load (1min/5min)					
R_{min} ohm	R_{max} ohm	I_{dc} A DC	I_{rms} A DC	P_{rcont} kW	I_{max} A DC	I_{dc} A DC	$I_{rms}-R_{min}$ A DC	$P_{br}-R_{min}$ kW	I_{dc} A DC	I_{rms} A DC	$P_{contmax}$ kW	I_{max} A DC	I_{dc} A DC	$I_{rms}-R_{max}$ A DC	$P_{br}-R_{max}$ kW		
3.0	3.6	781	310	870	370	999	351	1110	781	283	870	312	833	293	920	ACS880-604-0870-7	R8i
2.0	2.4	1171	465	1300	555	1499	527	1660	1171	425	1300	468	1249	439	1390	ACS880-604-1300-7	R8i
3.0	3.6	1562	621	1730	740	1998	702	2220	1562	567	1730	625	1665	585	1850	ACS880-604-1730-7	2xR8i
2.0	2.4	2342	931	2600	1110	2997	1053	3330	2342	850	2600	937	2498	878	2770	ACS880-604-2600-7	2xR8i
2.0	2.4	3514	1396	3900	1665	4496	1580	4990	3514	1275	3900	1405	3746	1316	4160	ACS880-604-3900-7	3xR8i
2.0	2.4	4685	1862	5200	2220	5994	2106	6650	4685	1700	5200	1874	4995	1755	5540	ACS880-604-5200-7	4xR8i
2.0	2.4	5856	2327	6500	2775	7493	2633	8320	5856	2125	6500	2342	6244	2194	6930	ACS880-604-6500-7	5xR8i

Dimensions

Frame size	Height (mm)	Width (mm)	Depth (mm)	Weight (kg)
R8i	1397	240	585	125

Resistor

R_{min}	Minimum allowed resistance value of the brake resistor for one phase of the brake module.
R_{max}	Resistance value of the brake resistor for one phase of the brake module corresponding to the maximum achieved continuous braking power.

Note: Connect one resistor per brake module phase. For example, a brake unit of frame size 2xR8i including two brake modules → 2 x 3 resistors are needed.

Typical ratings for no-overload use

I_{dc}	Total input DC current of brake unit.
I_{rms}	Total rms DC output phase current of brake unit.
I_{max}	Peak brake current (DC) per chopper module phase.
$P_{cont,max}$	Maximum continuous braking power per brake unit.

Cyclic load (1 min/5 min)

I_{dc}	Total input DC current of brake unit during a period of 1 minute with braking power P_{br} .
I_{rms}	Total rms DC current per brake unit phase during a period of 1 minute with braking power P_{br} .
P_{br}	Short term braking power

DC-DC converter ACS880-1604

$U_N = 400\text{ V}$ (range 380 to 415 V). The power ratings are valid at nominal voltage 400 V

No overload use					Fast overload cycle (10 s/60 s)	Heavy overload cycle (1 min/60 s)	Noise level	Heat dissipation	Air flow	Filter type	Type designation	Frame size		
I_{dc} input A (DC)	I_{rms} output A (DC)	P_N kW	I_{max} output A (DC)	I_{p2p} A	I_{fast} A	P_{fast} kW	I_{Hd} A	P_{Hd} kW	dBA	kW	m ³ /h			
600	600	305	900	22	450	229	510	260	74	5.2	2200	BDCL-14-5	ACS880-1604-0600A-3	R8i
900	900	458	1350	33	675	343	765	389	74	8	2200	BDCL-15-5	ACS880-1604-0900A-3	R8i
1200	1200	611	1800	44	899	458	1020	519	76	10.5	4400	2xBDCL-14-5	ACS880-1604-1200A-3	2xR8i
1800	1800	916	2700	65	1349	687	1529	779	76	16.5	4400	2xBDCL-15-5	ACS880-1604-1800A-3	2xR8i

$U_N = 500\text{ V}$ (range 380 to 415 V). The power ratings are valid at nominal voltage 500 V

No overload use					Fast overload cycle (10 s/60 s)	Heavy overload cycle (1 min/60 s)	Noise level	Heat dissipation	Air flow	Filter type	Type designation	Frame size		
I_{dc} input A (DC)	I_{rms} output A (DC)	P_N kW	I_{max} output A (DC)	I_{p2p} A	I_{fast} A	P_{fast} kW	I_{Hd} A	P_{Hd} kW	dBA	kW	m ³ /h			
600	600	382	900	27	450	286	510	324	74	6	2200	BDCL-14-5	ACS880-1604-0600A-5	R8i
900	900	573	1350	41	675	429	765	487	74	9.1	2200	BDCL-15-5	ACS880-1604-0900A-5	R8i
1200	1200	764	1800	55	899	572	1020	649	76	12.1	4400	2xBDCL-14-5	ACS880-1604-1200A-5	2xR8i
1800	1800	1146	2700	82	1349	859	1529	973	76	18.8	4400	2xBDCL-15-5	ACS880-1604-1800A-5	2xR8i

$U_N = 690\text{ V}$ (range 380 to 415 V). The power ratings are valid at nominal voltage 690 V

No overload use					Fast overload cycle (10 s/60 s)	Heavy overload cycle (1 min/60 s)	Noise level	Heat dissipation	Air flow	Filter type	Type designation	Frame size		
I_{dc} input A (DC)	I_{rms} output A (DC)	P_N kW	I_{max} output A (DC)	I_{p2p} A	I_{fast} A	P_{fast} kW	I_{Hd} A	P_{Hd} kW	dBA	kW	m ³ /h			
400	400	351	600	38	300	263	340	298	74	6.4	2200	BDCL-14-7	ACS880-1604-0400A-7	R8i
600	600	527	900	56	450	395	510	448	74	10.6	2200	BDCL-15-7	ACS880-1604-0600A-7	R8i
800	800	703	1200	75	600	527	680	597	76	12.8	4400	2xBDCL-14-7	ACS880-1604-0800A-7	2xR8i
1200	1200	1054	1800	113	899	790	1020	895	76	21.5	4400	2xBDCL-15-7	ACS880-1604-1200A-7	2xR8i

Dimensions

Frame size	Height mm	Width mm	Depth mm	Weight kg
R8i	1397	240	583	125
BDCL-14-5	1397	240	444	195
BDCL-14-7	1397	240	444	195
BDCL-15-5	1397	240	444	255
BDCL-15-7	1397	240	444	255

No overload use

I_{dc} input	Maximum continuous input DC current
I_{rms} output	Maximum continuous output current
P_N	Maximum continuous output power
I_{max} output	Maximum instantaneous output current
I_{p2p}	Maximum output ripple current

Fast/heavy load cycle

I_{fast}	Continuous output current allowing 10 s of I_{max} every 60 seconds
P_{fast}	Continuous output power allowing 10 s of I_{max} every 60 seconds
I_{Ld}	Continuous output current allowing overload of 150% I_{hd} for 1 min every 5 min
P_{Ld}	Continuous output power allowing 150% I_{hd} for 1 min every 5 min



du/dt filters

du/dt filtering suppresses inverter output voltage spikes and rapid voltage changes that stress motor insulation. Additionally, du/dt filtering reduces capacitive leakage currents and high frequency emission of the motor cable as well as high frequency losses and bearing currents in the motor. The need for du/dt filtering depends on the motor insulation. For information on the construction of the motor insulation, consult the manufacturer.

If the motor does not fulfill the following requirements, the lifetime of the motor might decrease. Insulated N-end (non-driven end) bearings and/or common mode filters are also required for motor bearing currents with motors bigger than 100 kW. For more information, please see the ACS880 hardware manuals.

Please see below about how to select a filter according to the motor.

Filter selection table for ACS880

Motor type	Nominal AC supply voltage	Motor insulation system	Requirements for	
			ABB du/dt and common mode filters, insulated N-end motor bearings	
			$P_N < 100 \text{ kW}$ and frame size < IEC 315	$100 \text{ kW} \leq P_N < 350 \text{ kW}$ or IEC 315 \leq frame size < IEC 400
			$P_N < 134 \text{ hp}$ and frame size < NEMA 500	$134 \text{ hp} \leq P_N < 469 \text{ hp}$ or NEMA 500 \leq frame size \leq NEMA 580
ABB motors				
Random-wound M2__, M3__ and M4__	$U_N \leq 500 \text{ V}$	Standard	-	+ N
	$500 \text{ V} < U_N \leq 600 \text{ V}$	Standard	+ du/dt	+ du/dt + N
		or Reinforced	-	+ N
	$600 \text{ V} < U_N \leq 690 \text{ V}$ (cable length $\leq 150 \text{ m}$)	Reinforced	+ du/dt	+ du/dt + N
$600 \text{ V} < U_N \leq 690 \text{ V}$ (cable length > 150 m)	Reinforced	-	+ N	
Form-wound HX__ and AM__	$380 \text{ V} < U_N \leq 690 \text{ V}$	Standard	n/a	+ N + CMF
Old ¹⁾ form-wound HX__ and modular	$380 \text{ V} < U_N \leq 690 \text{ V}$	Check with the motor manufacturer	+ du/dt with voltages over 500 V + N + CMF	
Random-wound HX__ and AM__ ²⁾	$0 \text{ V} < U_N \leq 500 \text{ V}$	Embedded wire with fiber glass taping	+ N + CMF	
	$500 \text{ V} < U_N \leq 690 \text{ V}$		+ du/dt + N + CMF	
HDP	Consult the motor manufacturer.			
Non-ABB motors				
Random-wound and form-wound	$U_N \leq 420 \text{ V}$	Standard $\hat{U}_{LL} = 1300 \text{ V}$	-	+ N or CMF
	$420 \text{ V} < U_N \leq 500 \text{ V}$	Standard $\hat{U}_{LL} = 1300 \text{ V}$	+ du/dt	+ du/dt + N or + du/dt + CMF
		or Reinforced: $\hat{U}_{LL} = 1600 \text{ V}$, 0.2 microsecond rise time	-	+ N or CMF
	$500 \text{ V} < U_N \leq 600 \text{ V}$	Reinforced: $\hat{U}_{LL} = 1600 \text{ V}$	+ du/dt	+ du/dt + N or + du/dt + CMF
		or Reinforced: $\hat{U}_{LL} = 1800 \text{ V}$	-	+ N or CMF
	$600 \text{ V} < U_N \leq 690 \text{ V}$	Reinforced: $\hat{U}_{LL} = 1800 \text{ V}$	+ du/dt	+ du/dt + N
Reinforced: $\hat{U}_{LL} = 2000 \text{ V}$, 0.3 microsecond rise time		-	+ N or CMF	

¹⁾ Manufactured before 1.1.1998. ²⁾ For motors manufactured before 1.1.1998, check for additional instructions with the motor manufacturer.

The abbreviations used in the table are defined below

Abbr.	Definition
U_N	Nominal AC line voltage.
\hat{U}_{LL}	Peak line-to-line voltage at motor terminals which the motor insulation must withstand.
P_N	Motor nominal power.
du/dt	du/dt filter at the output of the drive. Available both as standard and as an optional add-on kit from ABB.
CMF	Common mode filter. Depending on the drive type, CMF is available from ABB as a factory-installed option (+E208) or as an optional add-on kit.
N	N-end bearing: insulated motor non-drive end bearing.
n/a	Motors of this power range are not available as standard units. Consult the motor manufacturer.

du/dt filters

Applicability

Separate du/dt filters are available for ACS880-01/-04. Unprotected IP00 filters must be placed into an enclosure that provides an adequate degree of protection. ACS880-104 parallel connected R8i modules ranging from 380 to 690 V have du/dt filters built-in as standard. du/dt filters are also available as standard for 1xR8i, 690 V.

External du/dt filters for ACS880-01

ACS880			du/dt filter type (3 filters included in kits marked*)																
400 V	500 V	690 V	Unprotected (IP00)			Protected to IP22			Protected to IP54										
			NOCH0016-60	NOCH0030-60	NOCH0070-60	NOCH0120-60 ¹⁾	FOCH0260-70	FOCH0320-50	NOCH0016-62	NOCH0030-62	NOCH0070-62	NOCH0120-62	FOCH0260-72	FOCH0320-52	NOCH0016-65	NOCH0030-65	NOCH0070-65	NOCH0120-65	
02A4-3	02A1-5		x																
03A3-3	03A0-5		x																
	03A4-5		x																
04A0-3	04A8-5		x																
05A6-3	05A2-5		x																
07A2-3	07A6-5	07A3-7	x																
09A4-3		09A8-7	x																
12A6-3	11A0-5		x																
		14A2-7	x																
	014A-5			x															
017A-3		018A-7	x																
	021A-5	022A-7	x																
025A-3		026A-7	x																
	027A-5			x															
032A-3	034A-5	035A-7		x															
038A-3	040A-5	042A-7		x															
045A-3	052A-5	049A-7		x															
061A-3				x															
	065A-5	061A-7			x														
072A-3	077A-5				x														
087A-3		084A-7			x														
105A-3	096A-5	098A-7			x														
	124A-5	119A-7				x													
145A-3	156A-5	142A-7				x													
169A-3	180A-5	174A-7				x													
206A-3	240A-5	210A-7				x													
246A-3	260A-5	271A-7				x													
293A-3						x													
363A-3	361A-5						x												
430A-3	414A-5						x												

External du/dt filters for ACS880-04

ACS880-04			Unprotected (IP00)	
400 V	500 V	690 V	FOCH0610-70	FOCH0875-70
		330A-7	x	
		370A-7	x	
	460A-5	425A-7	x	
		430A-7	x	
505A-3	503A-5	470A-7	x	
585A-3	583A-5	522A-7	x	
650A-3	635A-5	590A-7	x	
725A-3	715A-5	650A-7		x
820A-3	820A-5	721A-7		x
880A-3	880A-5			x

External du/dt filters for ACS880-104

ACS880-104			Unprotected (IP00)			
400 V	500 V	690 V	BOCH-0350A-7	NOCH0016-60	NOCH0030-60	NOCH0070-60
0140A-3	0110A-5	0062A-7	x			
0170A-3	0140A-5	0082A-7	x			
0210A-3	0170A-5	0100A-7	x			
0250A-3	0200A-5	0130A-7	x			
0300A-3	0240A-5	0140A-7	x			
0350A-3	0300A-5	0190A-7	x			
	0340A-5	0220A-7	x			
		0270A-7	x			
004A8-3	003A6-5	007A3-7		x		
006A0-3	004A8-5	009A8-7		x		
008A0-3	006A0-5	14A2-7		x		
0011A-3	008A0-5			x		
0014A-3	0011A-5			x		
0018A-3	0014A-5			x		
	0018A-5			x		
0025A-3	0025A-5	0018A-7			x	
0030A-5		0022A-7			x	
0035A-3	0035A-5	0027A-7			x	
0044A-3		0035A-7				x
0050A-3	0050A-5	0042A-7				x
0061A-3	0061A-5	0052A-7				x
0078A-3	0078A-5					x
0094A-3	0094A-5					x
0100A-3						x

¹⁾ Values are for three single-phase filters.

²⁾ 3 filters included, dimensions apply for one filter.

Dimensions and weights of the du/dt filters

du/dt filter	Height (mm)	Width (mm)	Depth (mm)	Weight (kg)
BOCH-0350A-7 ¹⁾	310	347	256	16
NOCH0016-60	195	140	115	2.4
NOCH0016-62/65	323	199	154	6
NOCH0030-60	215	165	130	4.7
NOCH0030-62/65	348	249	172	9
NOCH0070-60	261	180	150	9.5
NOCH0070-62/65	433	279	202	15.5
NOCH0120-60 ²⁾	200	154	106	7
NOCH0120-62/65	765	308	256	45
NOCH0260-60 ²⁾	383	185	111	12
FOCH0260-70	382	340	254	47
FOCH0260-72	900	314	384	73
FOCH0320-50	662	319	293	65
FOCH0320-52	1092	396	413	100
FOCH0610-70	662	319	293	65
FOCH0875-70	662	319	293	65

Dimensioning tool for selecting the optimal drive

DriveSize is designed to help select the optimal drive, motor or transformer for the application. Based on data supplied by the user, the tool calculates and suggests which drive and motors to use. DriveSize uses technical specifications found in our technical catalogs and manuals. It provides default values which can be changed by the user.

DriveSize creates documents for drive and motor dimensioning based on the load, network and cooling data provided by the user. Dimensioning results can be viewed graphically and numerically in the tool.

The tool can be used to calculate currents and network harmonics for a single supply unit or a whole system. The user can import a user-defined motor database by using a separate template that comes with the installation package. DriveSize is easy to use and has shortcut keys to make navigation quicker.

Easy to access and use

DriveSize is a free software and can be used either online or downloaded for PC from www.abb.com/drives.



Summary of features and options

Power and voltage range	Ordering code	ACS880-01	ACS880-04	ACS880-04XT	ACS880-04	ACS880-14	ACS880-34
		Single drive modules with option +P940 or +P944	Single drive modules	Single drive modules	Single drive module packages (6- and 12- pulse)	Regenerative single drive module packages	Low harmonic single drive module packages
		Frame sizes R1 to R9	Frame sizes R10 to R11	Frame sizes 2xR10 to 2xR11	Frame sizes nxRxT+ nxR8i	Frame sizes nxR8i	Frame sizes nxR8i
		kW	kW	kW	kW	kW	kW
230 V		0.55 to 75	200 to 500	630 to 900	400 to 1400	160 to 1400	160 to 1400
400 V		0.55 to 250	200 to 630	800 to 1000	560 to 1400	200 to 1600	200 to 1600
500 V		0.55 to 250	200 to 630	800 to 1000	560 to 1400	200 to 1600	200 to 1600
690 V		4 to 250	250 to 710	800 to 1200	560 to 2200	200 to 2200	200 to 2200

Mounting							
For cabinet mounting	+P940, +P944	<input type="checkbox"/>	<input checked="" type="checkbox"/>	<input checked="" type="checkbox"/>	<input checked="" type="checkbox"/>	<input checked="" type="checkbox"/>	<input checked="" type="checkbox"/>
Mounting direction - bookshelf		<input checked="" type="checkbox"/>	<input checked="" type="checkbox"/>	<input checked="" type="checkbox"/>	<input checked="" type="checkbox"/>	<input checked="" type="checkbox"/>	<input checked="" type="checkbox"/>
Mounting direction - flat (= sideways)	+C173	<input type="checkbox"/>	<input checked="" type="checkbox"/>	<input checked="" type="checkbox"/>	<input checked="" type="checkbox"/>	<input checked="" type="checkbox"/>	<input checked="" type="checkbox"/>
Flange mounting	+C135	<input type="checkbox"/>	<input type="checkbox"/>	<input type="checkbox"/>	<input type="checkbox"/>	<input type="checkbox"/>	<input type="checkbox"/>
Side by side mounting		<input checked="" type="checkbox"/>	<input checked="" type="checkbox"/>	<input checked="" type="checkbox"/>	<input checked="" type="checkbox"/>	<input checked="" type="checkbox"/>	<input checked="" type="checkbox"/>
External drive control unit		<input type="checkbox"/>	<input checked="" type="checkbox"/>	<input checked="" type="checkbox"/>	<input checked="" type="checkbox"/>	<input checked="" type="checkbox"/>	<input checked="" type="checkbox"/>
Integrated drive control unit	+P905	<input checked="" type="checkbox"/>	<input type="checkbox"/>	<input type="checkbox"/>	<input type="checkbox"/>	<input type="checkbox"/>	<input type="checkbox"/>
Installation frames for drive modules		<input type="checkbox"/>	<input type="checkbox"/>	<input type="checkbox"/>	<input checked="" type="checkbox"/>	<input checked="" type="checkbox"/>	<input checked="" type="checkbox"/>
Wheels for easy maneuvering of the module		<input type="checkbox"/>	<input checked="" type="checkbox"/>	<input checked="" type="checkbox"/>	<input checked="" type="checkbox"/>	<input checked="" type="checkbox"/>	<input checked="" type="checkbox"/>
Cabling							
Supply bottom entry (module terminals)		<input checked="" type="checkbox"/>	<input type="checkbox"/>	<input type="checkbox"/>	<input checked="" type="checkbox"/>	<input checked="" type="checkbox"/>	<input checked="" type="checkbox"/>
Supply top entry (module terminals)		<input type="checkbox"/>	<input checked="" type="checkbox"/>	<input checked="" type="checkbox"/>	<input type="checkbox"/>	<input type="checkbox"/>	<input type="checkbox"/>
Inverter bottom exit (module terminals)		<input checked="" type="checkbox"/>	<input checked="" type="checkbox"/>	<input checked="" type="checkbox"/>	<input checked="" type="checkbox"/>	<input checked="" type="checkbox"/>	<input checked="" type="checkbox"/>
DC connection bus bars/terminals	+H356	<input checked="" type="checkbox"/>	<input type="checkbox"/>	<input type="checkbox"/>	<input checked="" type="checkbox"/>	<input checked="" type="checkbox"/>	<input checked="" type="checkbox"/>
Cabling panel for quick module installation/removal	+H381	<input type="checkbox"/>	<input type="checkbox"/>	<input type="checkbox"/>	<input type="checkbox"/>	<input type="checkbox"/>	<input type="checkbox"/>
Right hand side terminals (180 degrees turn)	+H391	<input type="checkbox"/>	<input type="checkbox"/>	<input type="checkbox"/>	<input type="checkbox"/>	<input type="checkbox"/>	<input type="checkbox"/>
Degree of protection							
IP00 (UL open type)	+0B051	<input type="checkbox"/>	<input type="checkbox"/>	<input type="checkbox"/>	<input checked="" type="checkbox"/>	<input checked="" type="checkbox"/>	<input checked="" type="checkbox"/>
IP20 (UL open type)		<input checked="" type="checkbox"/>	<input checked="" type="checkbox"/>	<input checked="" type="checkbox"/>	<input type="checkbox"/>	<input type="checkbox"/>	<input type="checkbox"/>
Motor control							
DTC (direct torque control)		<input checked="" type="checkbox"/>	<input checked="" type="checkbox"/>	<input checked="" type="checkbox"/>	<input checked="" type="checkbox"/>	<input checked="" type="checkbox"/>	<input checked="" type="checkbox"/>
Software							
Primary control program		<input checked="" type="checkbox"/>	<input checked="" type="checkbox"/>	<input checked="" type="checkbox"/>	<input checked="" type="checkbox"/>	<input checked="" type="checkbox"/>	<input checked="" type="checkbox"/>
Drive application programming based on IEC 61131-3 using Automation Builder	+N8010	<input type="checkbox"/>	<input type="checkbox"/>	<input type="checkbox"/>	<input type="checkbox"/>	<input type="checkbox"/>	<input type="checkbox"/>
Application control program for centrifuge/decanter	+N5150	<input type="checkbox"/>	<input type="checkbox"/>	<input type="checkbox"/>	<input type="checkbox"/>	<input type="checkbox"/>	<input type="checkbox"/>
Application control program for crane	+N5050	<input type="checkbox"/>	<input type="checkbox"/>	<input type="checkbox"/>	<input type="checkbox"/>	<input type="checkbox"/>	<input type="checkbox"/>
Application control program for dual use, f>598Hz, high speed product	+N8200	<input type="checkbox"/>	<input type="checkbox"/>	<input type="checkbox"/>	<input type="checkbox"/>	<input type="checkbox"/>	<input type="checkbox"/>
Application control program for ESP pumps	+N5600	<input type="checkbox"/>	<input type="checkbox"/>	<input type="checkbox"/>	<input type="checkbox"/>	<input type="checkbox"/>	<input type="checkbox"/>
Application control program for override control	+N5450	<input type="checkbox"/>	<input type="checkbox"/>	<input type="checkbox"/>	<input type="checkbox"/>	<input type="checkbox"/>	<input type="checkbox"/>
Application control program for PCP/ESP pump	+N5200	<input type="checkbox"/>	<input type="checkbox"/>	<input type="checkbox"/>	<input type="checkbox"/>	<input type="checkbox"/>	<input type="checkbox"/>
Application control program for chemical industry process control	+N5550	<input type="checkbox"/>	<input type="checkbox"/>	<input type="checkbox"/>	<input type="checkbox"/>	<input type="checkbox"/>	<input type="checkbox"/>
Application control program for Rod pump	+N5250	<input type="checkbox"/>	<input type="checkbox"/>	<input type="checkbox"/>	<input type="checkbox"/>	<input type="checkbox"/>	<input type="checkbox"/>
Application control program for spinning and traverse	+N5500	<input type="checkbox"/>	<input type="checkbox"/>	<input type="checkbox"/>	<input type="checkbox"/>	<input type="checkbox"/>	<input type="checkbox"/>
Application control program for test bench	+N5300	<input type="checkbox"/>	<input type="checkbox"/>	<input type="checkbox"/>	<input type="checkbox"/>	<input type="checkbox"/>	<input type="checkbox"/>
Application control program for winch	+N5100	<input type="checkbox"/>	<input type="checkbox"/>	<input type="checkbox"/>	<input type="checkbox"/>	<input type="checkbox"/>	<input type="checkbox"/>
Application control program for winder	+N5000	<input type="checkbox"/>	<input type="checkbox"/>	<input type="checkbox"/>	<input type="checkbox"/>	<input type="checkbox"/>	<input type="checkbox"/>
Support for asynchronous motor		<input checked="" type="checkbox"/>	<input checked="" type="checkbox"/>	<input checked="" type="checkbox"/>	<input checked="" type="checkbox"/>	<input checked="" type="checkbox"/>	<input checked="" type="checkbox"/>
Support for permanent magnet motor		<input checked="" type="checkbox"/>	<input checked="" type="checkbox"/>	<input checked="" type="checkbox"/>	<input checked="" type="checkbox"/>	<input checked="" type="checkbox"/>	<input checked="" type="checkbox"/>
Support for synchronous reluctance motor (SynRM)	+N7502	<input type="checkbox"/>	<input type="checkbox"/>	<input type="checkbox"/>	<input type="checkbox"/>	<input type="checkbox"/>	<input type="checkbox"/>
Control panel							
Intuitive control panel		<input checked="" type="checkbox"/>	<input checked="" type="checkbox"/>	<input checked="" type="checkbox"/>	<input checked="" type="checkbox"/>	<input checked="" type="checkbox"/>	<input checked="" type="checkbox"/>
Integrated control panel holder in the drive	+J414	<input checked="" type="checkbox"/>	<input type="checkbox"/>	<input type="checkbox"/>	<input type="checkbox"/>	<input type="checkbox"/>	<input type="checkbox"/>
Control panel mounting platform (flush), DPMP-01	+J410	<input checked="" type="checkbox"/>	<input type="checkbox"/>	<input type="checkbox"/>	<input checked="" type="checkbox"/>	<input checked="" type="checkbox"/>	<input checked="" type="checkbox"/>
Control panel mounting platform (surface), DPMP-02	+J413	<input checked="" type="checkbox"/>	<input type="checkbox"/>	<input type="checkbox"/>	<input checked="" type="checkbox"/>	<input checked="" type="checkbox"/>	<input checked="" type="checkbox"/>
Control connections (I/O) and communications							
2 pcs analog inputs, programmable, galvanically isolated		<input checked="" type="checkbox"/>	<input checked="" type="checkbox"/>	<input checked="" type="checkbox"/>	<input checked="" type="checkbox"/>	<input checked="" type="checkbox"/>	<input checked="" type="checkbox"/>
2 pcs analog outputs, programmable		<input checked="" type="checkbox"/>	<input checked="" type="checkbox"/>	<input checked="" type="checkbox"/>	<input checked="" type="checkbox"/>	<input checked="" type="checkbox"/>	<input checked="" type="checkbox"/>
6 pcs digital inputs, programmable, galvanically isolated - can be divided into two groups		<input checked="" type="checkbox"/>	<input checked="" type="checkbox"/>	<input checked="" type="checkbox"/>	<input checked="" type="checkbox"/>	<input checked="" type="checkbox"/>	<input checked="" type="checkbox"/>
2 pcs digital inputs/outputs		<input checked="" type="checkbox"/>	<input checked="" type="checkbox"/>	<input checked="" type="checkbox"/>	<input checked="" type="checkbox"/>	<input checked="" type="checkbox"/>	<input checked="" type="checkbox"/>
1 pcs digital input interlock		<input checked="" type="checkbox"/>	<input checked="" type="checkbox"/>	<input checked="" type="checkbox"/>	<input checked="" type="checkbox"/>	<input checked="" type="checkbox"/>	<input checked="" type="checkbox"/>
3 pcs relay outputs programmable		<input checked="" type="checkbox"/>	<input checked="" type="checkbox"/>	<input checked="" type="checkbox"/>	<input checked="" type="checkbox"/>	<input checked="" type="checkbox"/>	<input checked="" type="checkbox"/>
Safe torque off (STO)		<input checked="" type="checkbox"/>	<input checked="" type="checkbox"/>	<input checked="" type="checkbox"/>	<input checked="" type="checkbox"/>	<input checked="" type="checkbox"/>	<input checked="" type="checkbox"/>
Drive-to-drive link/Built-in Modbus		<input checked="" type="checkbox"/>	<input checked="" type="checkbox"/>	<input checked="" type="checkbox"/>	<input checked="" type="checkbox"/>	<input checked="" type="checkbox"/>	<input checked="" type="checkbox"/>
Assistant control panel/PC tool connection		<input checked="" type="checkbox"/>	<input checked="" type="checkbox"/>	<input checked="" type="checkbox"/>	<input checked="" type="checkbox"/>	<input checked="" type="checkbox"/>	<input checked="" type="checkbox"/>
Possibility for external power supply for control unit		<input checked="" type="checkbox"/>	<input checked="" type="checkbox"/>	<input checked="" type="checkbox"/>	<input checked="" type="checkbox"/>	<input checked="" type="checkbox"/>	<input checked="" type="checkbox"/>
Built-in I/O extension and speed feedback modules: for more details see sections: "Input/output extension modules for increased connectivity", "Speed feedback interfaces for precise process control" and "DDCS communication option modules"		<input type="checkbox"/>	<input type="checkbox"/>	<input type="checkbox"/>	<input type="checkbox"/>	<input type="checkbox"/>	<input type="checkbox"/>
Built-in adapters for several fieldbuses: for more details see section "Flexible connectivity to automation networks"		<input type="checkbox"/>	<input type="checkbox"/>	<input type="checkbox"/>	<input type="checkbox"/>	<input type="checkbox"/>	<input type="checkbox"/>

Summary of features and options

Power and voltage range	Ordering code	ACS880-01	ACS880-04	ACS880-04XT	ACS880-04	ACS880-14	ACS880-34
		Single drive modules with option +P940 or +P944	Single drive modules	Single drive modules	Single drive module packages (6- and 12- pulse)	Regenerative single drive module packages	Low harmonic single drive module packages
		Frame sizes R1 to R9	Frame sizes R10 to R11	Frame sizes 2xR10 to 2xR11	Frame sizes nxDxT+ nXR8i	Frame sizes nXR8i	Frame sizes nXR8i
230 V 400 V 500 V 690 V		kW	kW	kW	kW	kW	kW
		0.55 to 75	200 to 500	630 to 900	400 to 1400	160 to 1400	160 to 1400
		0.55 to 250	200 to 630	800 to 1000	560 to 1400	200 to 1600	200 to 1600
		4 to 250	250 to 710	800 to 1200	560 to 2200	200 to 2200	200 to 2200
EMC filters							
EMC 1 st environment, restricted distribution, C2, grounded network (TN)	+E202	<input type="checkbox"/> ⁹⁾	<input type="checkbox"/> ⁴⁾	<input checked="" type="checkbox"/> ⁴⁾	<input checked="" type="checkbox"/> ⁴⁾	<input checked="" type="checkbox"/> ⁴⁾	<input checked="" type="checkbox"/> ⁴⁾
EMC 2 nd environment, C3, grounded network (TN)	+E200	<input type="checkbox"/> ⁹⁾	<input type="checkbox"/> ⁹⁾	<input type="checkbox"/> ⁹⁾	-	-	-
EMC 2 nd environment, C3, ungrounded network (IT)	+E201	<input type="checkbox"/> ⁷⁾	<input type="checkbox"/> ⁹⁾	<input type="checkbox"/> ⁹⁾	-	-	-
EMC 2 nd environment, C3, grounded (TN) and ungrounded (IT)	+E210	-	<input type="checkbox"/> ⁴⁾	<input type="checkbox"/> ⁴⁾	<input checked="" type="checkbox"/> ¹¹⁾	<input checked="" type="checkbox"/> ¹¹⁾	<input checked="" type="checkbox"/> ¹¹⁾
Line filter							
AC or DC choke		<input checked="" type="checkbox"/>	<input checked="" type="checkbox"/>	<input checked="" type="checkbox"/>	<input checked="" type="checkbox"/>	-	-
LCL		-	-	-	-	<input checked="" type="checkbox"/>	<input checked="" type="checkbox"/>
Output filters							
Common mode filter	+E208	<input type="checkbox"/>	<input type="checkbox"/>	<input checked="" type="checkbox"/>	<input checked="" type="checkbox"/>	<input checked="" type="checkbox"/>	<input checked="" type="checkbox"/>
du/dt filters		<input checked="" type="checkbox"/>	<input checked="" type="checkbox"/>	<input checked="" type="checkbox"/>	<input checked="" type="checkbox"/>	<input checked="" type="checkbox"/>	<input checked="" type="checkbox"/>
Braking (see braking unit table)							
Brake chopper	+D150	<input type="checkbox"/> ⁹⁾	<input type="checkbox"/>	<input type="checkbox"/>	<input checked="" type="checkbox"/>	<input checked="" type="checkbox"/>	<input checked="" type="checkbox"/>
Brake resistor		<input checked="" type="checkbox"/>	<input checked="" type="checkbox"/>	<input checked="" type="checkbox"/>	<input checked="" type="checkbox"/>	<input checked="" type="checkbox"/>	<input checked="" type="checkbox"/>
Regenerative braking		-	-	-	-	<input checked="" type="checkbox"/>	-
Safety functions							
Safe torque off (STO)		<input checked="" type="checkbox"/>	<input checked="" type="checkbox"/>	<input checked="" type="checkbox"/>	<input checked="" type="checkbox"/>	<input checked="" type="checkbox"/>	<input checked="" type="checkbox"/>
Safety functions module, FSO-12, without encoder, programmable functions:	+Q973	<input type="checkbox"/>	<input type="checkbox"/>	<input checked="" type="checkbox"/>	<input checked="" type="checkbox"/>	<input checked="" type="checkbox"/>	<input checked="" type="checkbox"/>
Safe stop 1 (SS1)		<input checked="" type="checkbox"/>	<input checked="" type="checkbox"/>	<input checked="" type="checkbox"/>	<input checked="" type="checkbox"/>	<input checked="" type="checkbox"/>	<input checked="" type="checkbox"/>
Safely-limited speed (SLS)		<input checked="" type="checkbox"/>	<input checked="" type="checkbox"/>	<input checked="" type="checkbox"/>	<input checked="" type="checkbox"/>	<input checked="" type="checkbox"/>	<input checked="" type="checkbox"/>
Safe brake control (SBC)		<input checked="" type="checkbox"/>	<input checked="" type="checkbox"/>	<input checked="" type="checkbox"/>	<input checked="" type="checkbox"/>	<input checked="" type="checkbox"/>	<input checked="" type="checkbox"/>
Safe maximum speed (SMS)		<input checked="" type="checkbox"/>	<input checked="" type="checkbox"/>	<input checked="" type="checkbox"/>	<input checked="" type="checkbox"/>	<input checked="" type="checkbox"/>	<input checked="" type="checkbox"/>
Safe stop emergency (SSE)		<input checked="" type="checkbox"/>	<input checked="" type="checkbox"/>	<input checked="" type="checkbox"/>	<input checked="" type="checkbox"/>	<input checked="" type="checkbox"/>	<input checked="" type="checkbox"/>
Prevention of unexpected startup (POUS)		<input checked="" type="checkbox"/>	<input checked="" type="checkbox"/>	<input checked="" type="checkbox"/>	<input checked="" type="checkbox"/>	<input checked="" type="checkbox"/>	<input checked="" type="checkbox"/>
Safety functions module, FSO-21, with encoder support, programmable functions:	+Q972 ¹⁰⁾	<input type="checkbox"/>	<input type="checkbox"/>	<input checked="" type="checkbox"/>	<input checked="" type="checkbox"/>	<input checked="" type="checkbox"/>	<input checked="" type="checkbox"/>
Safe stop 1 (SS1)		<input checked="" type="checkbox"/>	<input checked="" type="checkbox"/>	<input checked="" type="checkbox"/>	<input checked="" type="checkbox"/>	<input checked="" type="checkbox"/>	<input checked="" type="checkbox"/>
Safely-limited speed (SLS)		<input checked="" type="checkbox"/>	<input checked="" type="checkbox"/>	<input checked="" type="checkbox"/>	<input checked="" type="checkbox"/>	<input checked="" type="checkbox"/>	<input checked="" type="checkbox"/>
Safe brake control (SBC)		<input checked="" type="checkbox"/>	<input checked="" type="checkbox"/>	<input checked="" type="checkbox"/>	<input checked="" type="checkbox"/>	<input checked="" type="checkbox"/>	<input checked="" type="checkbox"/>
Safe maximum speed (SMS)		<input checked="" type="checkbox"/>	<input checked="" type="checkbox"/>	<input checked="" type="checkbox"/>	<input checked="" type="checkbox"/>	<input checked="" type="checkbox"/>	<input checked="" type="checkbox"/>
Safe stop emergency (SSE)		<input checked="" type="checkbox"/>	<input checked="" type="checkbox"/>	<input checked="" type="checkbox"/>	<input checked="" type="checkbox"/>	<input checked="" type="checkbox"/>	<input checked="" type="checkbox"/>
Prevention of unexpected startup (POUS)		<input checked="" type="checkbox"/>	<input checked="" type="checkbox"/>	<input checked="" type="checkbox"/>	<input checked="" type="checkbox"/>	<input checked="" type="checkbox"/>	<input checked="" type="checkbox"/>
Safe direction (SDI), requires encoder feedback, FSE-31		<input checked="" type="checkbox"/>	<input checked="" type="checkbox"/>	<input checked="" type="checkbox"/>	<input checked="" type="checkbox"/>	<input checked="" type="checkbox"/>	<input checked="" type="checkbox"/>
Safe speed monitoring (SSM), requires encoder feedback, FSE-31		<input checked="" type="checkbox"/>	<input checked="" type="checkbox"/>	<input checked="" type="checkbox"/>	<input checked="" type="checkbox"/>	<input checked="" type="checkbox"/>	<input checked="" type="checkbox"/>
Pulse encoder interface module, FSE-31	+L521 ¹⁰⁾	<input type="checkbox"/>	<input type="checkbox"/>	<input checked="" type="checkbox"/>	<input checked="" type="checkbox"/>	<input checked="" type="checkbox"/>	<input checked="" type="checkbox"/>
PROFIsafe over profinet	+Q982	<input type="checkbox"/>	<input type="checkbox"/>	<input checked="" type="checkbox"/>	<input checked="" type="checkbox"/>	<input checked="" type="checkbox"/>	<input checked="" type="checkbox"/>
Earth fault monitoring, earthed mains		<input checked="" type="checkbox"/>	<input checked="" type="checkbox"/>	<input checked="" type="checkbox"/>	<input checked="" type="checkbox"/>	<input checked="" type="checkbox"/>	<input checked="" type="checkbox"/>
Earth fault monitoring, unearthed mains	+Q954	-	<input type="checkbox"/>	-	-	-	-
Auxiliary option kits							
Fuses, fuse base		-	-	-	<input checked="" type="checkbox"/>	<input checked="" type="checkbox"/>	<input checked="" type="checkbox"/>
Assembly kits for Rittal TS8 cabinets		-	-	<input checked="" type="checkbox"/>	<input checked="" type="checkbox"/>	<input checked="" type="checkbox"/>	<input checked="" type="checkbox"/>
IP20, IP42 and IP54 door and roof kits		-	<input checked="" type="checkbox"/>	<input checked="" type="checkbox"/>	<input checked="" type="checkbox"/>	<input checked="" type="checkbox"/>	<input checked="" type="checkbox"/>
Approvals							
CE		<input checked="" type="checkbox"/>	<input checked="" type="checkbox"/>	<input checked="" type="checkbox"/>	<input checked="" type="checkbox"/>	<input checked="" type="checkbox"/>	<input checked="" type="checkbox"/>
UL, cUL, CSA		<input checked="" type="checkbox"/>	<input checked="" type="checkbox"/>	<input checked="" type="checkbox"/>	<input checked="" type="checkbox"/>	<input checked="" type="checkbox"/>	<input checked="" type="checkbox"/>
EAC (EAC has replaced GOST R)		<input checked="" type="checkbox"/>	<input checked="" type="checkbox"/>	<input checked="" type="checkbox"/>	<input checked="" type="checkbox"/>	<input checked="" type="checkbox"/>	<input checked="" type="checkbox"/>
RoHS		<input checked="" type="checkbox"/>	<input checked="" type="checkbox"/>	<input checked="" type="checkbox"/>	<input checked="" type="checkbox"/>	<input checked="" type="checkbox"/>	<input checked="" type="checkbox"/>
C-Tick		<input checked="" type="checkbox"/>	<input checked="" type="checkbox"/>	<input checked="" type="checkbox"/>	-	-	-
Marine type approvals	+C132	<input type="checkbox"/> ⁹⁾	-	<input type="checkbox"/> ⁹⁾	<input type="checkbox"/> ⁹⁾	<input type="checkbox"/> ⁹⁾	<input type="checkbox"/> ⁹⁾
TUV Nord certificate for safety functions	+Q973	<input checked="" type="checkbox"/>	<input checked="" type="checkbox"/>	<input checked="" type="checkbox"/>	<input checked="" type="checkbox"/>	<input checked="" type="checkbox"/>	<input checked="" type="checkbox"/>
VTT ATEX protective device certificate	+Q973	<input type="checkbox"/>	<input type="checkbox"/>	<input type="checkbox"/>	<input type="checkbox"/>	<input type="checkbox"/>	<input type="checkbox"/>

- Standard
- Selectable option, with plus code
- Selectable option, external, no plus code
- Not available

Notes

- ¹⁾ Only for 6-pulse D8T module
- ²⁾ Pending
- ³⁾ Earthed network, frame sizes R1 to R9, 380 to 500 V
- ⁴⁾ For 380 to 500 V
- ⁵⁾ Earthed network, frame sizes R6 to R9, 380 to 500 V

⁶⁾ For 525 to 690 V

⁷⁾ Unearthed network, frame sizes R6 to R9 380 to 500 V, frame sizes R7 to R9, 690 V

⁸⁾ Frame sizes R1 to R4 built-in and R5 to R9 as selectable option

⁹⁾ Contact ABB to check all approved bodies

¹⁰⁾ For availability please check with your local ABB

¹¹⁾ The drive must be installed according to the instructions given in the manuals

¹²⁾ Not available for -04F

Summary of features and options

Power and voltage range	Ordering code	ACS880-104 inverter modules	ACS880-204 ISU (IGBT supply unit)	ACS880-304 DSU (diode supply unit) DxD (6-pulse)	ACS880-304 DSU (diode supply unit) DxT (6- and 12-pulse)	ACS880-904 RRU (regenerative rectifier unit)	ACS880-604 Brake units	ACS880-1604 DC-DC converter
		Frame sizes R1i to n×R8i	Frame sizes R1i to R4i, R6i and n×R8i	Frame sizes D6D to D8D	Frame sizes 2×D7T and n×D8T	Frame sizes n×R8i	Frame sizes n×R8i	Frame sizes n×R8i
		kW	kVA	kVA	kVA	kVA	kVA	kVA
230 V								
400 V		1.5 to 2800	5.5 to 3319	55 to 679	453 to 3788	416 to 2397		
500 V		1.5 to 3200	5.7 to 3593	69 to 849	566 to 4735	520 to 2966		
690 V		4 to 3200	366 to 3679		683 to 5445	717 to 4135		

Mounting								
For cabinet mounting		●	●	●	●	●	●	●
Mounting direction - bookshelf		●	●	●	●	●	●	●
Mounting direction - flat (= sideways)		■ ¹⁾	■ ¹⁾	■ ¹⁾	■ ¹⁾	■ ¹⁾	■ ¹⁾	■ ¹⁾
Flange mounting		—	—	—	—	—	—	—
Side by side mounting		●	●	—	●	●	●	●
External drive control unit		● ²⁾	● ²⁾	●	●	●	●	●
Integrated drive control unit		● ³⁾	● ³⁾	—	—	—	—	—
Installation frames for drive modules		■ ⁵⁾	■ ⁵⁾	—	■ ⁵⁾	—	—	—
Wheels for easy maneuvering of the module		● ⁶⁾	● ⁶⁾	● ⁶⁾	● ⁶⁾	●	● ⁶⁾	●
Cabling								
Supply bottom entry (module terminals)		—	●	●	●	●	●	●
Supply top entry (module terminals)		—	—	—	—	—	—	—
Inverter bottom exit (module terminals)		●	—	—	—	—	—	—
DC connection bus bars/terminals		●	●	●	●	●	●	●
Degree of protection								
IP00 (UL open type)		●	●	●	●	●	●	●
IP20 (UL open type)		—	—	—	—	—	—	—
Motor control								
DTC (direct torque control)		●	—	—	—	—	—	—
Software								
Primary control program		●	—	—	—	—	—	—
Drive application programming based on IEC 61131-3 using Automation Builder	+N8010	□	□	—	—	—	—	□
Application control program for crane	+N5050	□	—	—	—	—	—	—
Application control program for dual use, f>598Hz, high speed product	+N8200	□	—	—	—	—	—	—
Application control program for ESP pumps	+N5600	□	—	—	—	—	—	—
Application control program for override control	+N5450	□	—	—	—	—	—	—
Application control program for PCP/ESP pump	+N5200	□	—	—	—	—	—	—
Application control program for PCP/ESP pump with SynRM	+N5400	□	—	—	—	—	—	—
Application control program for test bench	+N5300	□	—	—	—	—	—	—
Application control program for winch	+N5100	□	—	—	—	—	—	—
Application control program for winder	+N5000	□	—	—	—	—	—	—
Support for asynchronous motor		●	—	—	—	—	—	—
Support for permanent magnet motor		●	—	—	—	—	—	—
Support for synchronous reluctance motor (SynRM)	+N7502	□	—	—	—	—	—	—
Control panel								
Intuitive control panel		■	■	■	■	■	■	■
Integrated control panel holder in the drive	+J414	— ⁸⁾	—	—	—	—	—	—
Control panel mounting platform (flush), DPMP-01		■	■	■	■	■	■	■
Control panel mounting platform (surface), DPMP-02		■	■	■	■	■	■	■
Control connections (I/O) and communications								
2 pcs analog inputs, programmable, galvanically isolated		●	●	●	●	●	● ¹³⁾	●
2 pcs analog outputs, programmable		●	●	●	●	●	● ¹³⁾	●
6 pcs digital inputs, programmable, galvanically isolated - can be divided into two groups		●	●	●	●	●	● ¹³⁾	●
2 pcs digital inputs/outputs		●	●	●	●	●	● ¹³⁾	●
1 pcs digital input interlock		●	●	●	●	●	● ¹³⁾	●
3 pcs relay outputs programmable		●	●	●	●	●	● ¹³⁾	●
Safe torque off (STO)		●	—	—	—	—	—	—
Drive-to-drive link/Built-in Modbus		●	●	●	●	●	● ¹³⁾	●
Assistant control panel/PC tool connection		●	●	●	●	●	● ⁹⁾	●
Possibility for external power supply for control unit		●	●	●	●	●	●	●
Built-in I/O extension and speed feedback modules: for more details see sections: "Input/output extension modules for increased connectivity", "Speed feedback interfaces for precise process control" and "DDCS communication option modules"		□	□	□	□	□	□	□
Built-in adapters for several fieldbuses: for more details see section "Flexible connectivity to automation networks"		□	□	□	□	□	□	□

Summary of features and options

Power and voltage range	Ordering code	ACS880-104 inverter modules	ACS880-204 ISU (IGBT supply unit)	ACS880-304 DSU (diode supply unit) DxT (6-pulse)	ACS880-304 DSU (diode supply unit) DxT (6- and 12-pulse)	ACS880-904 RRU (regenerative rectifier unit) (6-pulse)	ACS880-604 Brake units	ACS880-1604 DC-DC converter
		Frame sizes R1i to n×R8i	Frame sizes R1i to R4i, R6i and n×R8i	Frame sizes D6D to D8D	Frame sizes 2×D7T and n×D8T	Frame sizes n×R8i	Frame sizes n×R8i	Frame sizes n×R8i
		kW	kVA	kVA	kVA	kVA	kVA	kVA
230 V								
400 V		1.5 to 2800	5.5 to 3319	55 to 679	453 to 3788	416 to 2397		
500 V		1.5 to 3200	5.7 to 3593	69 to 849	566 to 4735	520 to 2966		
690 V		4 to 3200	366 to 3679		683 to 5445	717 to 4135		

EMC filters								
EMC 1 st environment, restricted distribution, C2, grounded network (TN)	+E202	–	■ ¹⁴⁾	–	■ ¹⁴⁾	–	–	–
EMC 2 nd environment, C3, grounded (TN) and ungrounded (IT)	+E210	● ¹⁵⁾	● ¹⁵⁾	● ¹⁵⁾	● ¹⁵⁾	● ¹⁵⁾	● ¹⁵⁾	● ¹⁵⁾
Line filter								
AC or DC choke		–	–	●	●	–	–	–
LCL or L		–	●	–	–	●	–	–
Output filters								
Common mode filter		● ¹⁶⁾	● ⁹⁾	–	–	●	●	●
du/dt filters		● ¹⁰⁾	● ¹¹⁾	–	–	● ¹²⁾	● ¹²⁾	● ¹²⁾
Braking (see braking unit table)								
Brake chopper		– ¹⁷⁾	–	–	–	–	●	–
Brake resistor		■	–	–	–	–	■	–
Regenerative braking		–	●	–	–	●	–	–
Safety functions								
Safe torque off (STO)		●	–	–	–	–	–	–
Safety functions module, FSO-12, without encoder, programmable functions:		■	–	–	–	–	–	–
Safe stop 1 (SS1)		–	–	–	–	–	–	–
Safely-limited speed (SLS)		–	–	–	–	–	–	–
Safe brake control (SBC)		–	–	–	–	–	–	–
Safe maximum speed (SMS)		–	–	–	–	–	–	–
Safe stop emergency (SSE)		–	–	–	–	–	–	–
Prevention of unexpected startup (POUS)		–	–	–	–	–	–	–
Safety functions module, FSO-21, with encoder, programmable functions:		■	–	–	–	–	–	–
Safe stop 1 (SS1)		–	–	–	–	–	–	–
Safely-limited speed (SLS)		–	–	–	–	–	–	–
Safe brake control (SBC)		–	–	–	–	–	–	–
Safe maximum speed (SMS)		–	–	–	–	–	–	–
Safe stop emergency (SSE)		–	–	–	–	–	–	–
Prevention of unexpected startup (POUS)		–	–	–	–	–	–	–
Safe direction (SDI), requires encoder feedback, FSE-31		–	–	–	–	–	–	–
Safe speed monitoring (SSM), requires encoder feedback, FSE-31		–	–	–	–	–	–	–
Pulse encoder interface module, FSE-31		■	–	–	–	–	–	–
PROFIsafe over profinet		■	–	–	–	–	–	–
Earth fault monitoring, earthed mains		●	●	–	●	●	–	–
Earth fault monitoring, unearthed mains		–	–	–	–	–	–	–
Auxiliary option kits								
Fuses, fuse base		■	■	■	■	■	■	■
DC-fuse switch		■	–	–	–	–	■	■
Assembly kits for Rittal TS8 cabinets		■	■	■	■	■	■	■
IP22 to IP54 door and roof kits		■	■	■	■	■	■	■
Approvals								
CE		●	●	●	●	●	●	●
UL, cUL, CSA		●	●	●	●	●	●	●
EAC (EAC has replaced GOST R)		●	●	●	●	●	●	●
RoHS		–	●	●	●	●	●	●
C-Tick		–	–	–	–	–	–	–
Marine type approvals	+C132	□ ^{19,20)}	□ ^{19,20)}	–	□ ¹⁹⁾	–	□ ¹⁹⁾	□ ¹⁹⁾
TÜV Nord certificate for safety functions	+Q973	● ¹¹⁾	–	–	–	–	–	–
VTT ATEX protective device certificate	+Q973	□	–	–	–	–	–	–

- Standard
- Selectable option, with plus code
- Selectable option, external, no plus code
- Not available

Notes

- ¹⁾ The drive must be installed according to the instructions given in the manuals. Possible for frames R6i-R8i, DxT, DxT, BLCL-, BL- and BDCL-filters
- ²⁾ R1i to R7i on the module
- ³⁾ R8i as external
- ⁴⁾ Only for R8i module
- ⁵⁾ Only for R6i-R8i modules, 6-pulse DxT modules and BLCL-filters
- ⁶⁾ R1i-R7i, D6D, D7D and D7T modules and 1-phase brake chopper without wheels
- ⁷⁾ Pending
- ⁸⁾ R1i to R5i as standard

⁹⁾ Available for R8i and R6i

¹⁰⁾ Optional in frame sizes R1i to R8i and 400 V/500 V

¹¹⁾ For availability contact your local ABB representative

¹²⁾ Not available for 1-pulse brake unit

¹⁴⁾ For 380 to 500 V and for ISU frame sizes up to 1xR8i and for 1xD8T

¹⁵⁾ The drive must be installed according to the instructions given in the manuals

¹⁶⁾ Available for R6i-R8i

¹⁷⁾ Internal with R1i to R4i

¹⁸⁾ Only for frame sizes R5i-R8i

¹⁹⁾ Contact ABB to check all approved bodies

²⁰⁾ ACS880-104 and ACS880-204 frames R1i-R4i do not have marine type approval (+C132)

Drives service Your choice, your future

The future of your drives depends on the service you choose.

Whatever you choose, it should be a well-informed decision. No guesswork. We have the expertise and experience to help you find and implement the right service for your drive equipment. You can start by asking yourself these two critical questions:

- Why should my drive be serviced?
- What would my optimal service options be?

From here, you have our guidance and full support along the course you take, throughout the entire lifetime of your drives.

Your choice, your business efficiency

ABB Drive Care agreement lets you focus on your core business. A selection of predefined service options matching your needs provides optimal, more reliable performance, extended drive lifetime and improved cost control. So you can reduce the risk of unplanned downtime and find it easier to budget for maintenance.

We can help you more by knowing where you are!

Register your drive at www.abb.com/drivereg for extended warranty options and other benefits.



Service to match your needs

Your service needs depend on your operation, life cycle of your equipment and business priorities. We have identified our customers' four most common needs and defined service options to satisfy them. What is your choice to keep your drives at peak performance?

Is uptime your priority?

Keep your drives running with precisely planned and executed maintenance.

Example services include:

- ✓ Life Cycle Assessment
- ✓ Installation and Commissioning
- ✓ Spare Parts
- ✓ Preventive Maintenance
- ✓ Reconditioning
- ✓ ABB Drive Care agreement
- ✓ Drive Exchange

Is rapid response a key consideration?

If your drives require immediate action, our global network is at your service.

Example services include:

- ✓ Technical Support
- ✓ On-site Repair
- ✓ Remote Support
- ✓ Response time agreements
- ✓ Training

Need to extend your assets' lifetime?

Maximize your drive's lifetime with our services.

Example services include:

- ✓ Life Cycle Assessment
- ✓ Upgrades, Retrofits and Modernization
- ✓ Replacement, Disposal and Recycling

Is performance most critical to your operation?

Get optimal performance out of your machinery and systems.

Example services include:

- ✓ Advanced services
- ✓ Engineering and Consulting
- ✓ Inspection and Diagnostics
- ✓ Upgrades, Retrofits and Modernization
- ✓ Workshop Repair
- ✓ Tailored services



Operational efficiency



Rapid response



Life cycle management



Performance improvement

Drives service A lifetime of peak performance

You're in control of every life cycle phase of your drives. At the heart of drive services is a four-phase product life cycle management model. This model defines the services recommended and available throughout drives lifespan.

Now it's easy for you to see the exact service and maintenance available for your drives.

ABB drives life cycle phases explained:

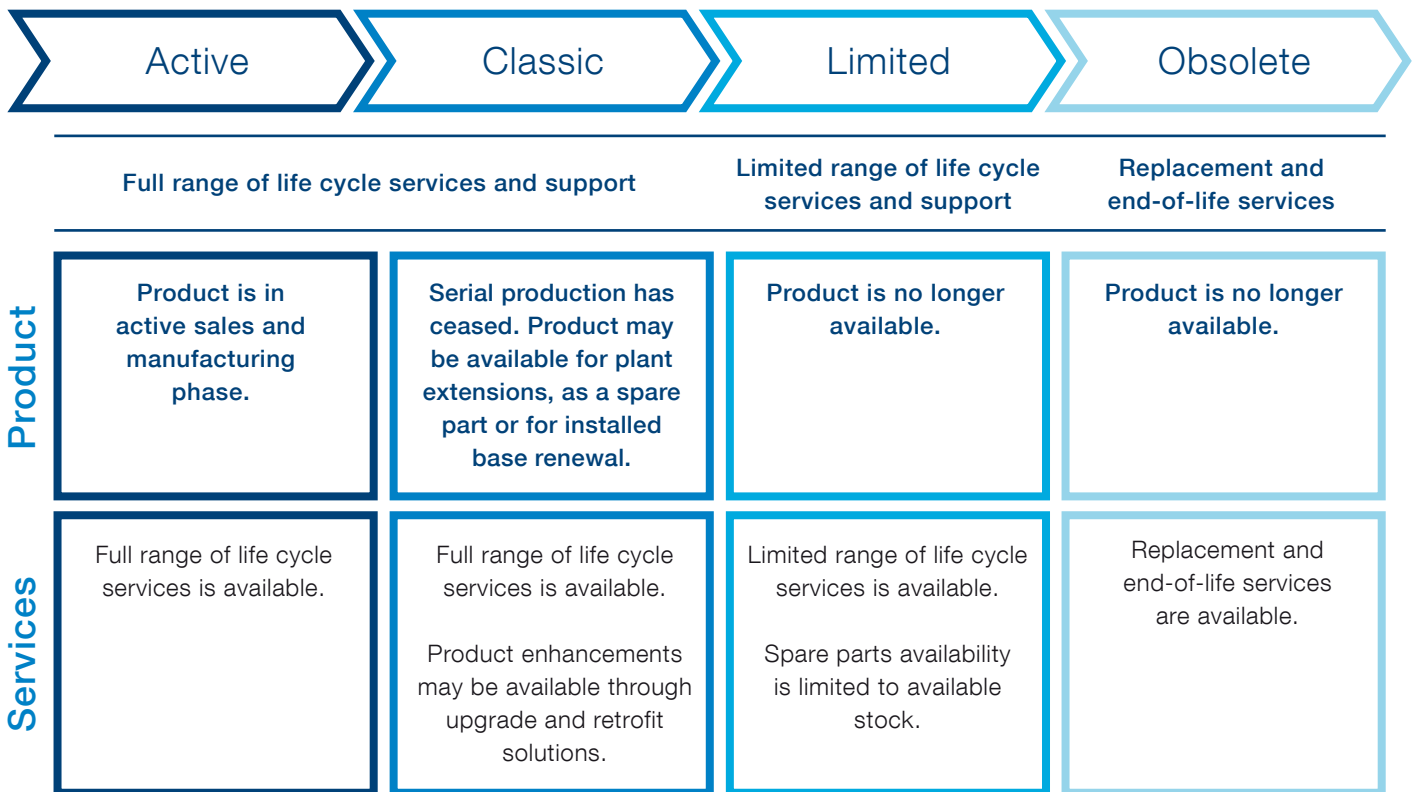

Keeping you informed

We notify you every step of the way using life cycle status statements and announcements.

Your benefit is clear information about your drives' status and precise services available. It helps you plan the preferred service actions ahead of time and make sure that continuous support is always available.

Step 1 Life Cycle Status Announcement

Provides early information about the upcoming life cycle phase change and how it affects the availability of services.

Step 2 Life Cycle Status Statement

Provides information about the drive's current life cycle status, availability of product and services, life cycle plan and recommended actions.