

## DIRECTIONAL CONTROL VALVES SOLENOID OPERATED

### HD5-ES-\*

120 l/min 35 MPa (350 bar)

#### 1 DESCRIPTION

Valves HD5-ES are directional control valve with subplate mounting interface acc. to ISO 4401, DIN 24340 (CETOP 05).

The design of the body is a quality five chamber casting.

The valve is available with interchangeable metallic DC solenoids, also for AC power supply using a built-in rectifier bridge inside the coil.

In the standard version, the valve housing is phosphated for 240 h salt spray protection acc. to ISO 9227. Enhanced surface protection for mobile sector available (ISO 9227, 520 h salt spray).



#### 2 ORDERING CODE

(1)	(2)	(3)	(4)	(5)	(6)
HD5	-	ES	-	-	/ 20

(1) HD5 : 4-way directional control valve CETOP 05 – Pressure 32 MPa (320 bar)

(2) ES : electrically controlled, standard

(3) Spool type (see 4)

-number is the main spool type

-letter is the solenoid or spring arrangement:

C : 2 sol. , spool is spring centered (3 position)

N : 2 sol. , spool is detented (2 position)

LL : 1 sol. (a), spool is spring offset (2 pos. , end to end)

ML: 1 sol. (a), spool is spring centered (2 pos. , middle to end)

LM: 1 sol. (a), spool is spring offset (2 pos. , end to middle)

(4) Code reserved for special variants:

b: only for version LL, ML, LM, solenoid b installed (instead of a)

T\* : soft shifting device (see 12 and 13)

K : water proof caps on override pin (see 14)

Z\* : anti-corrosion variants (see 16)

DR: solenoid(s) chamber draining (see 15)

(5) Electric voltage and solenoid coils (see 8, 9, 10)

(6) 20: design number (progressive) of the valve

ISO 4401-05-04-0-05  
(CETOP 4.2-4-05-320)

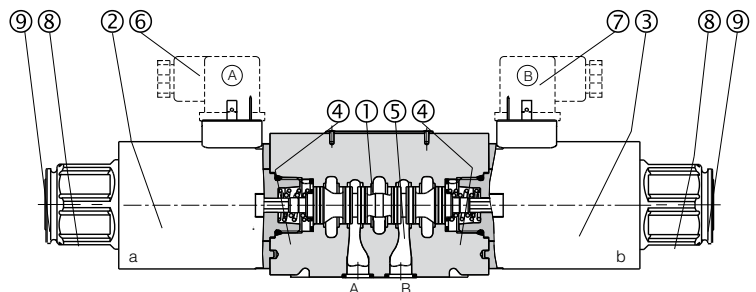
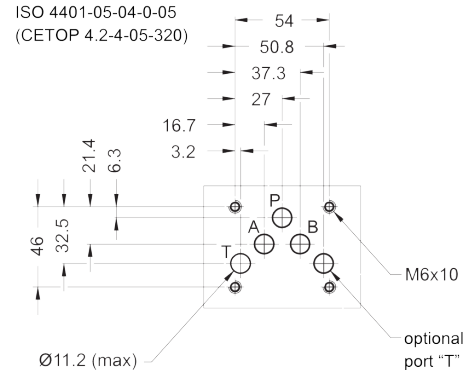

The spool 1 shifts into the valve body 7 subject to the action of springs and solenoids 2 and 3. Spool 1, depending from its shape and its position in the valve body 7, opens and/or closes passages between P, A, B and T ports, thus controlling the direction of the hydraulic flow. In case of electric cut-offs the spool can be manually shifted by acting on the override pins 9, located at the end of the solenoids and accessible through the retaining nuts.

### 3 TECHNICAL DATA

Nominal flow	120 l/min
Max. rec. flow	see 5
Nominal pressure (P, A, B)	32 MPa (320 bar)
Max. rec. Pressure (P, A, B)	35 MPa (350 bar)
Max. rec. Pressure (T port)	21 MPa (210 bar)
Pressure drops	see 6
Protection to DIN 40050	IP 65
Duty cycle	100 %
Service life	> 10 <sup>7</sup> cycles
Mass	1 sol. 3,9 kg 2 sol. 5,4 kg

### 4 SPOOL IDENTIFICATION AND INTERMEDIATE POSITION TRANSITORIES

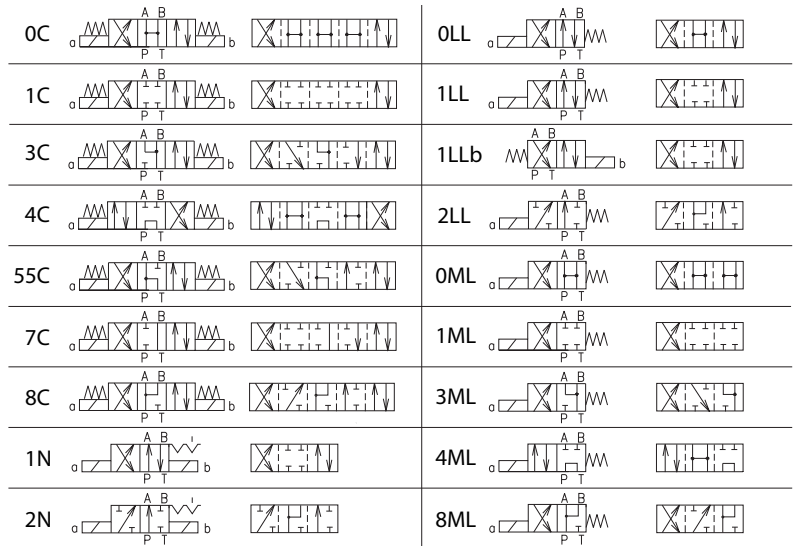

### 5 TYPICAL DIAGRAMS

Typical  $\Delta p$  curves for valves HD5-ES-\*, with mineral oil at  $v=32 \text{ mm}^2/\text{s}$  and  $t=40^\circ\text{C}$ , for flow  $P \rightarrow A/B$ ,  $A/B \rightarrow T$  and  $P \rightarrow T$

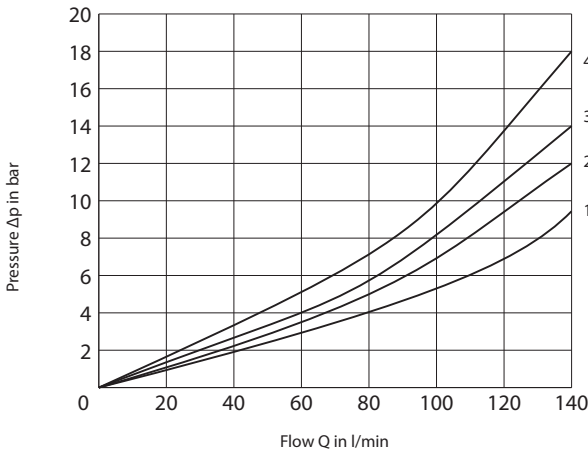

Spool type	P-A	P-B	A-T	B-T	P-T
0C	1	1	2	2	1
1C	1	1	2	2	-
3C	1	1	2	2	-
4C	3	3	4	4	1
55C	1	1	1	2	2
7C	1	1	2	2	-
8C	1	1	2	2	-
1N	1	1	2	3	-
2N	1	1	-	-	-
0LL	1	1	1	3	-
1LL	1	1	2	2	-
1LLb	1	1	2	2	-
2LL	1	1	-	-	-
0ML	-	1	2	-	1
1ML	-	1	2	-	-
3ML	-	1	2	-	-
4ML	3	-	-	4	1
8ML	-	1	2	-	-

### 6 HYDRAULIC LIMIT OF USE

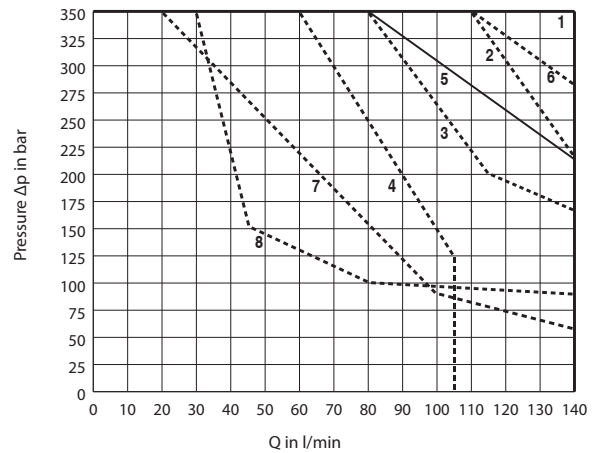

Spool type	Limit
0C	1
1C	
8C	
0ML	
1ML	5
8ML	
3C	
3ML	
4C	3
55C	7
7C	4
1N	6
2N	8
0LL	2
1LL	2
1LLb	2
2LL	8
4ML	3

## 7 INSTALLATION DIMENSION (mm)

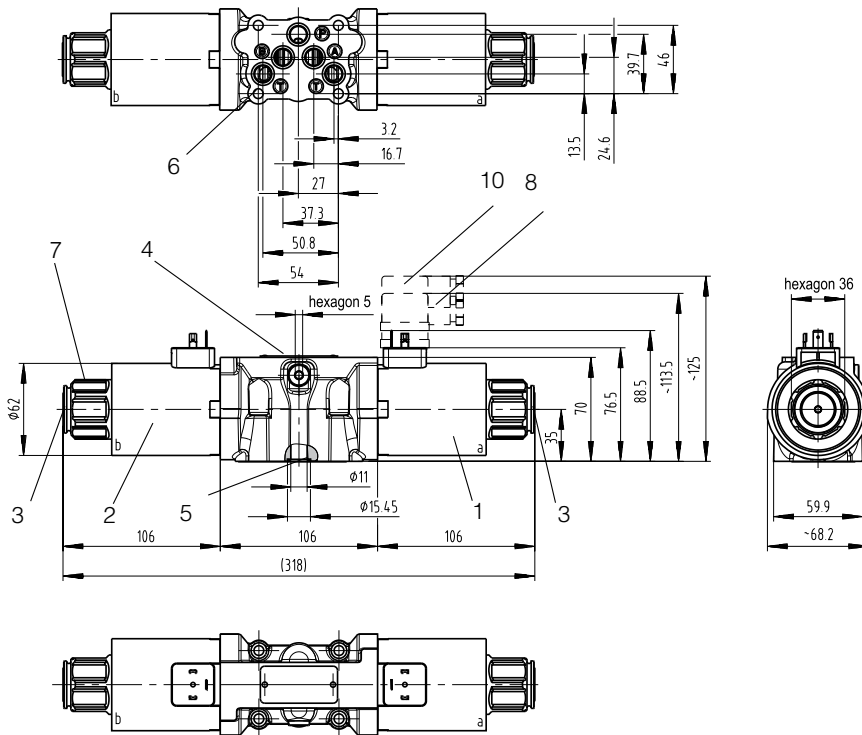

All valves HD5-ES-\* conform with ISO and CETOP specifications for mounting surface dimensions and for valves height.

When assembled to its mounting plate, valve HD5-ES-\* must be fastened with 4 fixing bolts (socket head screws to ISO 4762) M6 x 40 mm (or M6 x\* according to the number of modules) of class 12,9 (ISO898) tightened at 12 Nm torque.

Leakage between valve and mounting surface is prevented by the positive compression on their seats of 5 seals of Quad-Ring type 12,42 x 1,68 x 1,68 mm.

## 8 SOLENOID COILS, WITH STANDARD ELECTRIC CONNECTION TO ISO 4400 / DIN 43650, FOR DC SUPPLY

Standard valves type HD5-ES-\* are operated by solenoid that are energized directly from a D.C. voltage supply. Solenoid valves can be supplied without electric coils as HD5-ES\*-0000 and coils can be supplied separately as B05-\*\*\*C.

Directly from D.C. supply			
Voltage	Valve Code	Coil Code	Nominal Current (A)
V 12 DC	HD5-ES-*-*-012C	B05-012C	3,17
V 24 DC	HD5-ES-*-*-024C	B05-024C	1,73

Permissible supply voltage variation : +5% -10%  
Special voltages available : V 48 DC, V 106 DC, V 205 DC

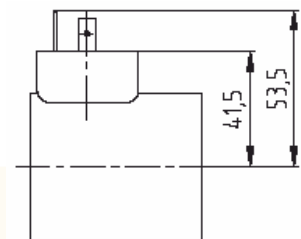

## 9 SOLENOID COILS, WITH STANDARD ELECTRIC CONNECTION TO ISO 4400 / DIN 43650, FOR AC SUPPLY

Valves type HD5-ES-\* can be operated from A.C. supply by the use of coils that incorporate a full wave bridge rectifier. Coils with rectifier can be supplied separately as B05-\*\*\*A.

Directly from A.C. supply			
Voltage	Valve Code	Coil Code	Nominal Current (A)
V 115 AC / 50 (60) Hz	HD5-ES-*-*-115A	B05-115A	0,40
V 230 AC / 50 (60) Hz	HD5-ES-*-*-230A	B05-230A	0,20

Permissible supply voltage variation : +5% -10%  
Special voltages available : V 48 DC, V 106 DC, V 205 DC

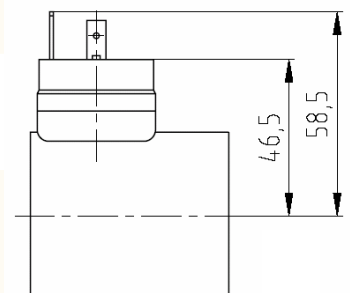

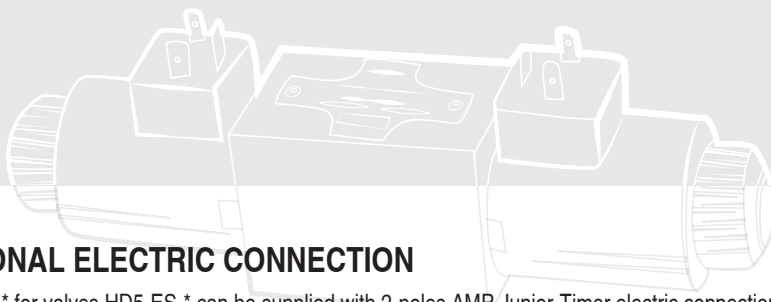

## 10 OPTIONAL ELECTRIC CONNECTION

Coils type B05-\* for valves HD5-ES-\* can be supplied with 2-poles AMP Junior-Timer electric connection. Coils with AMP connection can be supplied separately as B05-\*\*\*CAMP

AMP electric connection			
Voltage	Valve Code	Coil Code	Nominal Current (A)
V 12 DC	HD5-ES-*-*-012 CAMP	B05-012CAMP	3,17
V 24 DC	HD5-ES-*-*-024 CAMP	B05-024CAMP	1,73

Other optional electric connection are available :

- Flying Leads
- Flying Leads (250 mm) with Deutsch connection (DT04-2P)

## 11 VERSION "N" : MECHANICAL DETENT ON SPOOL

Solenoids valves with detent typically are 2 position, 2 solenoid, no-spring valves where the spool is kept at the extreme ends of its stroke by a mechanical device. This permits that solenoids are energized by short time current pulses and the spool remains at its position regardless of forces due to hydrodynamics or gravitational/inertial effects (vibrations).

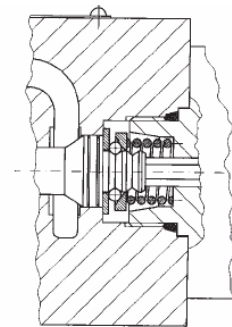

## 12 VERSION "T": SOFT SHIFTING

Solenoid valves with soft shifting devices are 2 or 3 position valves which incorporated a fixed throttling orifice ( $\varnothing$  0,6 mm) on the channel that connects the extreme hydraulic chambers of the valve. The throttling effect controls the spool shifting time, thus limiting unwanted hydraulic shocks.

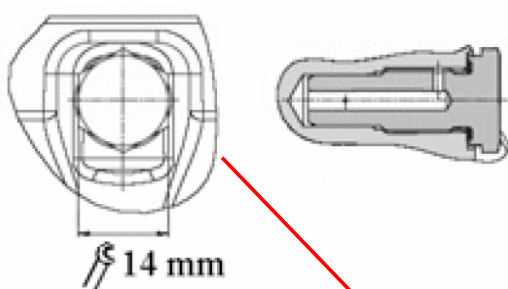

## 13 VERSION "TR": ADJUSTABLE SOFT SHIFTING

In Version "TR" valves, the fixed orifice is replaced by an adjustable, variable throttle valve that permit a fine and precise adjustment of the spool shifting time. To increase the throttling (and therefore the shifting time) turn clock-wise the adjusting screw (Ch. 3 mm), after having unlocked its retaining nut (Ch. 10 mm).

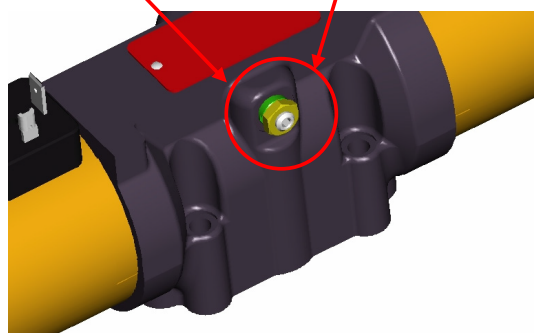
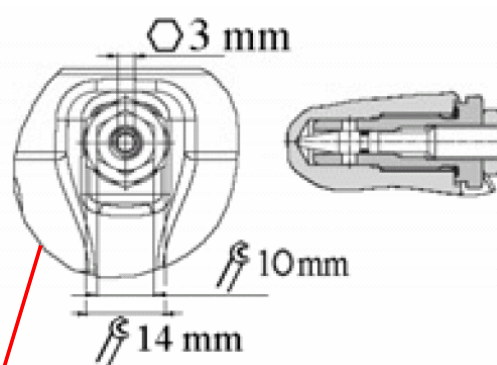

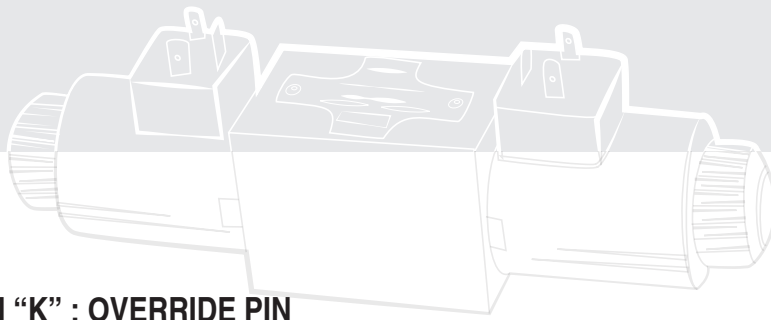

## 14 VERSION "K" : OVERRIDE PIN

Solenoid valves according to "K" version have override actuators that push on the valve's override pins and permit a quick and easy "hand operation" of the valves, without the need of any tool. The override actuator is incorporated in a flexible rubber cap that is easily applicable on the solenoid retaining nuts and that protects from moisture and water splashes.

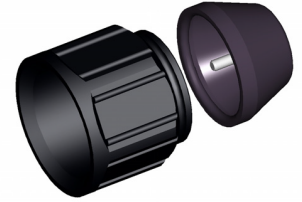
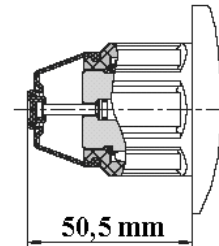

## 15 VERSION "DR" : SEPARATE DRAINING OF THE SOLENOID CHAMBER

Solenoid valves according to "DR" version present a draining line of the chambers of the solenoids. This version should be adopted in presence of high counterpressure on T line that exceed the permissible recommended maximum pressure for T ports of the valve (210 bar). Position of additional draining port DR is conform with ISO 4401-05 interface and correspond to the Y port.

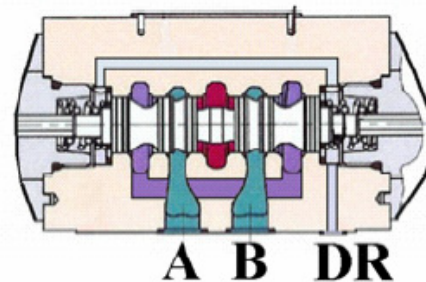
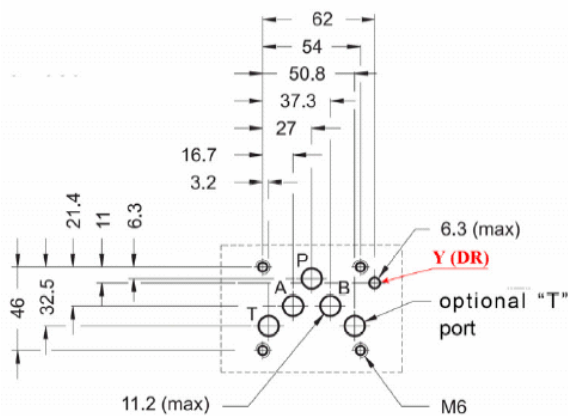

## 16 ANTICORROSION OPTIONS

On HD5-ES-\* standard valves the body is phosphate coated, the solenoid tubes are not treated and coils mantel and irons are zinc trivalent plated. To increase the resistance to corrosive agents different variants are available :

ZT : • Body, solenoid tubes and coils irons are zinc trivalent plated

ZL : • Body is coated with special TEMADUR 40 zinc painting  
• Solenoids have 8-12 µm zinc plating

ZK : • Body is coated with special TEMADUR 40 zinc painting  
• Solenoids tube and coils irons are "zinc-nickel" plated

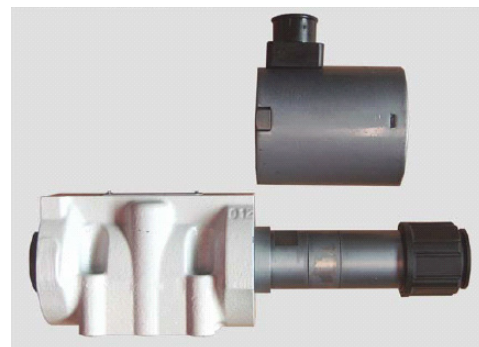

Example of ZK painted valve : HD5-ES-1LLb-ZK-024C/20