

## PILOT OPERATED CHECK VALVES

### AM3-CP-\*

60 l/min - 32 MPa (320 bar)

#### 1 DESCRIPTION

Pilot operated check valve. All the internal part are made with high strenght steel and are machined with accuracy in order to assure the requested tightness. The controlled lines are A, B or AB. The standard surafce treatment of the body is phosphate coated. Plugs are zinc coated.

#### 2 ORDERING CODE

(1)	(2)	(3)	(4)	(5)	(6)
AM3	-	CP	-	-	/ 10

(1) AM3: stackable valve CETOP 03 - Pressure 32 MPa (320 bar)

(2) CP: check valve. spring operated (hydraulically)

(3) Service lines where the controls operate:

AB: pilot operated checks on A and B, fluids flows A -> A1 and B -> B1 and flow A1 -> A (or B1 -> B) is permitted only when B (or A) is pressurized

A : pilot operated check on A; flow A1 -> A is permitted only when B is pressurized

B : pilot operated check on B; flow B1 -> B is permitted only when A is pressurized

(4) check valve opening (cracking) pressure (Pm)

for free flow A->A1 and B->B1:

no designation (standard): Pm approx 0.2 MPa (2 bar)

4: Pm approx 0.4 MPa (4 bar)

(5) Code reserved for option and variants

(6) Design number (progressive) of the valves

#### AM3-CP-A

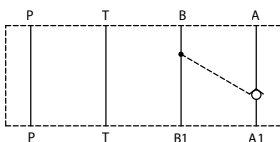

#### AM3-CP-AB

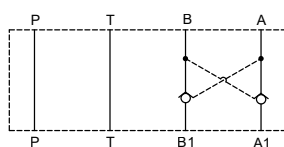

#### AM3-CP-B

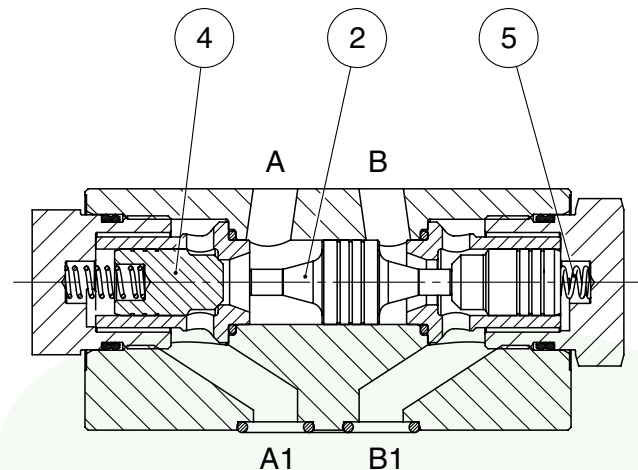
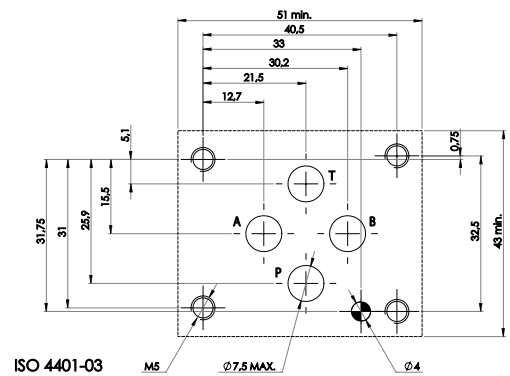
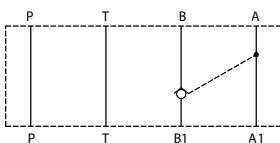

Fluid flows freely on P and T lines;

On service lines A and/or B with p.o. check, fluid flows from A ->A1 (and/ or B ->B1) overcoming the force of spring 5 acting on poppet 4, and fluid is blocked from A1 ->A (and/or B1 -> B). When, by switching the solenoid operated 4-way directional valve, pressure is made available at, for instance, port B fluid flows B -> B1 and the pilot piston 3, shifting from its central position, forces poppet 2, on service line A, to open and permit flow A1 -> A.

### 3 TECHNICAL DATA

Maximum nominal flow		Piloting pressure:
Maximum rec. flow rate	60 l/min	To shift the pilot piston and to open the check in A the piloting pressure must be at B:
Maximum nominal pressure	32 MPa (320 bar)	$P_p = P_b = \frac{P_{a1} + P_m - P_a + P_a}{3,5}$
Pressure drops	see 4	where: P <sub>p</sub> = piloting pressure
Pilot area ration piston/check valve	approx 3,5	P <sub>b</sub> = pressure in B
Installation and dimensions	see 5	P <sub>a</sub> = pressure in A
Mass	approx 1 kg	P <sub>a1</sub> = pressure in A
		P <sub>m</sub> = check valve opening pressure (spring)
		or to open the check in B
		$P_p = P_a = \frac{P_{b1} + P_m - P_b}{3,5} + P_b$

### 4 TYPICAL DIAGRAMS

Typical Δp-Q curves for valves AM3-CP in standard configuration, with mineral oil at 36 cSt and at 50°C

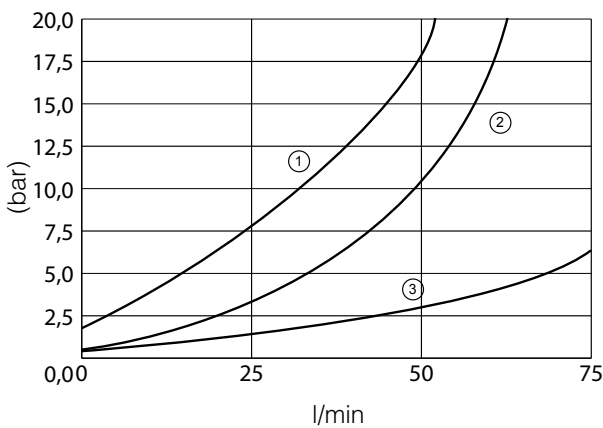

- ① A->A1      ② A1->A      ③ P<->P  
 B->B1      B1->B      T<->T

### 6 HYDRAULIC FLUIDS

Seals and materials used on standard valves AM3 - \* are fully compatible with hydraulic fluids of mineral oil base, upgraded with antifoaming and antioxidantizing agents. The hydraulic fluid must be kept clean and filtered to ISO 4406 class 19/17/14, or better, and used in a recommended viscosity range from 10 cSt to 60 cSt.

### 5 INSTALLATION DIMENSIONS (mm)

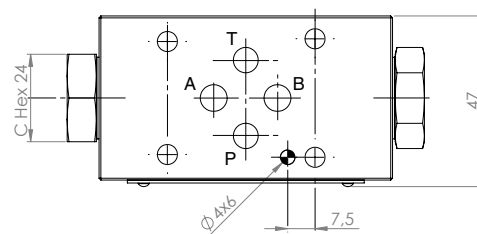
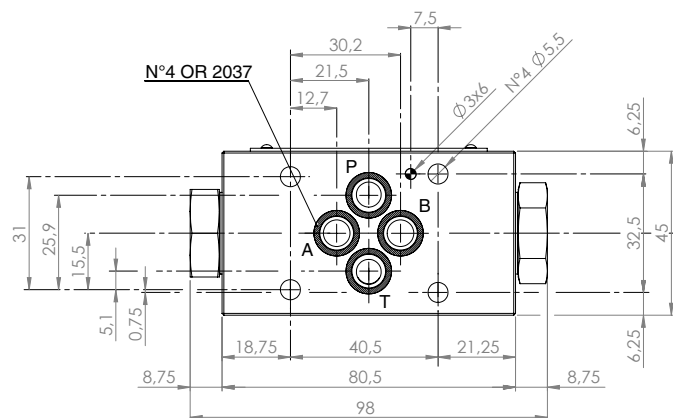

All stackable valves AM3-CP-\*/10 conform with ISO and CETOP specifications for mounting surface dimensions. Valves height 40 mm. Leakage between valve and mounting surface is prevented by the positive compression on their seats of 4 seals. All valves have on their "mounting" surface a ø 3.4 mm cylindrical hole and have on their "seals" surface a ø 3 mm cylindrical hole, conform with ISO and CETOP norms.