

USER MANUAL

# EMX3 Soft Starter



**RIGHT FROM  
THE START**

**AuCom**  
MOTOR CONTROL SPECIALISTS

# Contents

<b>1. About This Manual.....</b>	<b>2</b>	10.2 Adjustment Lock.....	38
1.1 Disclaimer .....	2	10.3 Access Code .....	39
<b>2. Caution Statements .....</b>	<b>3</b>	10.4 Quick Setup.....	39
2.1 Electrical shock risk .....	3	10.5 Standard Menu .....	40
2.2 Unexpected Operation .....	3	10.6 Extended Menu .....	41
2.3 Avertissements à l'attention des clients canadiens.....	4	10.7 Load/Save Settings.....	45
<b>3. Introduction .....</b>	<b>6</b>	10.8 Parameter Descriptions .....	46
3.1 Feature List .....	6	<b>11. Application Examples.....</b>	<b>62</b>
<b>4. Basic Setup .....</b>	<b>7</b>	11.1 Installation with Main Contactor.....	62
4.1 Setup Procedure Overview.....	7	11.2 Installation with External Bypass Contactor.....	63
4.2 Testing the Installation .....	7	11.3 Emergency Run Operation.....	64
4.3 Simulation Tools.....	8	11.4 Auxiliary Trip Circuit .....	65
<b>5. Installation .....</b>	<b>9</b>	11.5 DC Brake with External Zero Speed Sensor .....	66
5.1 Physical Installation .....	9	11.6 Soft Braking.....	67
5.2 Control Terminals .....	9	11.7 Two-Speed Motor .....	68
5.3 Control Voltage .....	9	11.8 Slip-Ring Motor.....	69
5.4 Control Wiring.....	10	<b>12. Troubleshooting .....</b>	<b>71</b>
5.5 Relay Outputs.....	10	12.1 Protection Responses.....	71
5.6 Motor Thermistors .....	10	12.2 Trip Messages.....	71
5.7 RTD/PT100.....	11	12.3 General Faults.....	75
5.8 Earth Terminals.....	11	<b>13. Appendix.....</b>	<b>77</b>
5.9 Power Input and Output Configurations.....	11	13.1 Model code .....	77
5.10 Power Terminations.....	13	13.2 IEC ratings .....	77
5.11 Schematic Diagrams.....	14	13.3 NEMA motor ratings .....	80
<b>6. Power Circuits .....</b>	<b>15</b>	13.4 Minimum and Maximum Current Settings.....	82
6.1 Motor Connection .....	15	13.5 Dimensions and Weights.....	83
6.2 Bypass Contactor.....	19	13.6 Specifications .....	85
6.3 Main Contactor.....	19	13.7 UL Compliant Installation.....	87
6.4 Circuit Breaker.....	19	13.8 Disposal Instructions .....	87
6.5 Power Factor Correction.....	19	13.9 Accessories .....	88
6.6 Short Circuit Protection Devices (SCPD).....	19	13.10 Parameter Values.....	89
6.7 UL Short Circuit Ratings.....	20	<b>14. Busbar Adjustment Procedure .....</b>	<b>93</b>
6.8 Fuse Selection for Type 2 Coordination.....	22		
<b>7. Keypad and Feedback .....</b>	<b>23</b>		
7.1 The Keypad .....	23		
7.2 Displays.....	24		
<b>8. Maintenance Tools .....</b>	<b>26</b>		
8.1 Testing the Installation .....	26		
8.2 Commissioning Menu (Tools) .....	26		
8.3 Logs Menu .....	29		
<b>9. Operation .....</b>	<b>31</b>		
9.1 Priority of Commands.....	31		
9.2 Start, Stop and Reset Commands.....	31		
9.3 Soft Start Methods.....	32		
9.4 Stop Methods .....	34		
9.5 Jog Operation.....	37		
9.6 Inside Delta Operation .....	37		
<b>10. Programming Menu.....</b>	<b>38</b>		
10.1 Programming Menu .....	38		

# 1. About This Manual

**WARNING**

Indicates a hazard that may cause personal injury or death.

**CAUTION**

Indicates a hazard that may damage the equipment or installation.

**NOTE**

Provides helpful information.

## 1.1 Disclaimer

The examples and diagrams in this manual are included solely for illustrative purposes.

The information contained in this manual is subject to change at any time and without prior notice. In no event will responsibility or liability be accepted for direct, indirect or consequential damages resulting from the use or application of this equipment.

© 2017 AuCom Electronics Ltd. All Rights Reserved.

As AuCom is continuously improving its products it reserves the right to modify or change the specification of its products at any time without notice. The text, diagrams, images and any other literary or artistic works appearing in this document are protected by copyright. Users may copy some of the material for their personal reference but may not copy or use material for any other purpose without the prior consent of AuCom Electronics Ltd. AuCom endeavours to ensure that the information contained in this document including images is correct but does not accept any liability for error, omission or differences with the finished product.

## 2. Caution Statements

Caution Statements cannot cover every potential cause of equipment damage but can highlight common causes of damage. It is the installer's responsibility to read and understand all instructions in this manual prior to installing, operating or maintaining the equipment, to follow good electrical practice including applying appropriate personal protective equipment and to seek advice before operating this equipment in a manner other than as described in this manual.



### NOTE

The EMX3 is not user serviceable. The unit should only be serviced by authorised service personnel. Unauthorised tampering with the unit will void the product warranty.

### 2.1 Electrical shock risk



#### WARNING – ELECTRICAL SHOCK RISK

The voltages present in the following locations can cause severe electric shock and may be lethal:

- AC supply cables and connections
- Output cables and connections
- Many internal parts of the starter

The AC supply must be disconnected from the starter using an approved isolation device before any cover is removed from the starter or before any servicing work is performed.



#### WARNING - ELECTRICAL SHOCK HAZARD

Models EMX3-0500B-EMX3-1600C: The busbar and heatsink must be treated as live whenever the unit has mains voltage connected (including when the starter is tripped or waiting for a command).



#### SHORT CIRCUIT

The EMX3 is not short circuit proof. After severe overload or short circuit, the operation of the EMX3 should be fully tested by an authorised service agent.



#### GROUNDING AND BRANCH CIRCUIT PROTECTION

It is the responsibility of the user or person installing the EMX3 to provide proper grounding and branch circuit protection according to local electrical safety codes.



#### FOR YOUR SAFETY

- The STOP function of the soft starter does not isolate dangerous voltages from the output of the starter. The soft starter must be disconnected by an approved electrical isolation device before accessing electrical connections.
- Soft starter protection features apply to motor protection only. It is the user's responsibility to ensure safety of personnel operating machinery.
- The soft starter is a component designed for integration within an electrical system; it is therefore the responsibility of the system designer/user to ensure the system is safe and designed to comply with relevant local safety standards.

### 2.2 Unexpected Operation



#### WARNING – ACCIDENTAL STARTS

In some installations, accidental starts may pose an increased risk to safety of personnel or damage to the machines being driven. In such cases, it is recommended that the power supply to the soft starter is fitted with an isolating switch and a circuit-breaking device (eg power contactor) controllable through an external safety system (eg emergency stop, fault detector).



#### WARNING – STARTER MAY START OR STOP UNEXPECTEDLY

The EMX3 will respond to control commands from various sources, and could start or stop unexpectedly. Always disconnect the soft starter from mains voltage before accessing the starter or load.



#### AUTO-START

Use the auto-start feature with caution. Read all the notes related to auto-start before operation.

**WARNING – DISCONNECT MAINS BEFORE ACCESSING STARTER OR LOAD**

The soft starter has built-in protections which can trip the starter in the event of faults and thus stop the motor. Voltage fluctuations, power cuts and motor jams may also cause the motor to trip.

The motor could restart after the causes of shutdown are rectified, which may be dangerous for personnel. Always disconnect the soft starter from mains voltage before accessing the starter or load.

**CAUTION – MECHANICAL DAMAGE FROM UNEXPECTED RESTART**

The motor could restart after the causes of shutdown are rectified, which may be dangerous for certain machines or installations. In such cases, it is essential that appropriate arrangements are made against restarting after unscheduled stops of the motor.

**2.3 Avertissements à l'attention des clients canadiens****AVERTISSEMENT**

L'icône AVERTISSEMENT ci-contre signale les informations concernant des risques pouvant entraîner des blessures graves, voire mortelles. Pour votre sécurité, veuillez consulter les avertissements sur cette page ou demander une copie du présent manuel en français auprès de votre distributeur local.

**AVERTISSEMENT – RISQUE DE CHOC ÉLECTRIQUE**

Les zones suivantes sont soumises à des tensions pouvant provoquer des risques de chocs électriques graves, voire mortels :

- Raccordement et câbles d'alimentation AC
- Câbles et raccordements de sortie
- De nombreuses pièces internes du démarreur

L'alimentation AC doit être déconnectée du démarreur au moyen d'un dispositif d'isolation agréé avant de retirer des capots ou avant de procéder à des travaux d'entretien.

**AVERTISSEMENT - DANGER D'ELECTROCUTION**

Modèles EMX3-0500B à EMX3-1600C : Les barres de puissance et le radiateur doivent être traités comme étant des éléments sous tension si l'appareil est relié au secteur (y compris lorsque le démarreur s'est mis en sécurité ou s'il attend une commande).

**PAR SECURITE**

- La fonction STOP du démarreur progressif n'isole pas des tensions dangereuses de la sortie du démarreur. Le démarreur progressif doit être déconnecté par un dispositif d'isolement électrique approprié avant d'accéder aux connexions électriques.
- Les fonctions de protection du démarreur progressif ne concernent que la protection du moteur. Il relève de la responsabilité de l'utilisateur d'assurer la sécurité des personnes travaillant sur les machines.
- Le démarreur progressif est un appareil conçu pour s'intégrer dans un système électrique ; il relève donc de la responsabilité du concepteur ou de l'utilisateur de veiller à ce que ce système soit sûr et conçu selon les normes de sécurité locales en vigueur.

**AVERTISSEMENT – DÉMARRAGES ACCIDENTELS**

Dans certaines installations, des démarrages accidentels peuvent provoquer un risque supplémentaire pour la sécurité des personnes ou endommager les machines contrôlées. Dans de tels cas, il est recommandé de doter l'alimentation du démarreur progressif d'un interrupteur d'isolement et d'un coupe-circuit (par exemple, un disjoncteur) contrôlable à partir d'un système de sécurité externe (par exemple, un arrêt d'urgence, un détecteur de défaut).

**AVERTISSEMENT – LE DÉMARREUR PEUT DÉMARRER OU S'ARRÊTER À TOUT MOMENT**

Le EMX3 répond aux commandes de contrôle de différentes origines et peut par conséquent démarrer ou s'arrêter à tout moment. Toujours déconnecter le démarreur de la tension secteur avant d'accéder au démarreur ou à la charge.

**DEMARRAGE AUTOMATIQUE**

Utiliser la fonction de démarrage automatique avec précautions. Lire toutes les notes relatives au démarrage automatique avant utilisation.



**AVERTISSEMENT**

Cette fonction ne doit pas être utilisée en association avec la commande à distance 2 fils.

Le démarreur progressif acceptera encore les commandes de démarrage et d'arrêt issues des entrées de commande à distance ou du réseau de communication série. Pour désactiver la commande locale ou à distance, utiliser le paramètre 6Q.

Si le démarrage automatique est activé et que l'utilisateur navigue dans le système de menus, ce démarrage ne deviendra actif que si aucune activité du clavier n'est détectée pendant cinq minutes.



**AVERTISSEMENT**

Le bouton STOP (ARRET) du clavier est toujours actif. Lors de l'utilisation d'une commande à distance 2 fils, le démarreur progressif redémarrera si les entrées de démarrage/arrêt et de reset sont toujours actives.



**AVERTISSEMENT – DÉCONNECTER L'ALIMENTATION PRINCIPALE AVANT D'ACCÉDER AU DÉMARREUR OU À LA CHARGE**

Le démarreur progressif comporte des protections intégrées qui peuvent déclencher des mises en sécurité dans l'éventualité de défauts et ainsi arrêter le moteur. Des fluctuations de tension, des coupures d'alimentation et des blocages du moteur peuvent produire des mises en sécurité de celui-ci.

Le moteur pourrait redémarrer une fois que les causes de l'arrêt ont été résolues, ce qui pourrait mettre en danger le personnel. Toujours déconnecter le démarreur de la tension secteur avant d'accéder au démarreur ou à la charge.



**AVERTISSEMENT**

Ne pas appliquer la tension du secteur au démarreur tant que tout le câblage n'est pas terminé.



**AVERTISSEMENT**

Toujours appliquer la tension de commande avant (ou en même temps que) la tension secteur.



**AVERTISSEMENT**

Lors du raccordement du EMX3 en connexion 6 fils, toujours installer un contacteur principal ou un disjoncteur magnéto-thermique à bobine de déclenchement.

## 3. Introduction

### 3.1 Feature List

#### Selectable soft starting profiles

- Adaptive Control
- Constant Current
- Current Ramp

#### Selectable soft stopping profiles

- Coast To Stop
- Timed voltage ramp soft stop
- Adaptive Control
- Brake

#### Extensive input and output options

- Remote control inputs  
(3 x fixed, 2 x programmable)
- Relay outputs  
(1 x fixed, 3 x programmable)
- Analog output
- Built-in PT100 RTD input
- Optional expansion cards

#### Easy-to-read display with comprehensive feedback

- Removable keypad
- Multi-language feedback
- Date and time stamped event logging
- Operational counters (number of starts, hours-run, kWh)
- Performance monitoring (current, voltage, power factor, kWh)
- User-programmable monitoring screen

#### Customisable protection

- Motor overload
- Excess Start Time
- Undercurrent
- Instantaneous overcurrent
- Current imbalance
- Mains frequency
- Input Trip
- Motor thermistor
- Power circuit
- Phase sequence

#### Models for all connection requirements

- 23 A~1600 A (nominal)
- 200~440 VAC
- 380~690 VAC
- Internally bypassed options
- In-line or inside delta connection

#### Optional features for advanced applications

- Input/output expansion
- RTD and Ground fault protection
- Communication modules: Ethernet (Profinet, Modbus TCP, Ethernet/IP), Profibus, DeviceNet, Modbus RTU, and USB

## 4. Basic Setup

### 4.1 Setup Procedure Overview



#### WARNING

Do not apply mains voltage to the starter until all wiring is complete.

1. Mount the soft starter (refer to *Physical Installation* on page 9 for details).
2. Connect control wiring (refer to *Control Terminals* on page 9 for details).
3. Apply control voltage to the starter.
4. Set the date and time (refer to *Set Date and Time* on page 26 for details).
5. Configure your application:
  1. Press **MENU** to open the Menu.
  2. Use ▼ to scroll to Quick Setup and press ► to open the Quick Setup menu.
  3. Scroll through the list to find your application, then press ► to begin the configuration process (refer to *Quick Setup* on page 39 for details).
6. If your application is not listed in Quick Setup:
  1. Press ◀ to return to the Menu.
  2. Use ▼ to scroll to Standard Menu and press ►.
  3. Scroll to Motor Data 1 and press ►, then press ► again to edit parameter 1A *Motor Full Load Current*.
  4. Set parameter 1A to match the motor's full load current (FLC).



#### NOTE

For advanced applications, refer to *Extended Menu* on page 41 and *Parameter Descriptions* on page 46.

7. Close the Menu by pressing ◀ repeatedly.
8. (Optional) Use the built-in simulation tools to check that the control wiring is connected correctly (refer to *Run Simulation* on page 27).
9. Connect mains supply cables to starter input terminals 1/L1, 3/L2, 5/L3 (refer to *Power Input and Output Configurations* on page 11).
10. Connect the motor cables to starter output terminals 2/T1, 4/T2, 6/T3.

The soft starter is now ready to control the motor.

### 4.2 Testing the Installation

The EMX3 can be connected to a small motor for testing. During this test, the soft starter's control input and relay output protection settings can be tested. This test mode is not suitable for testing soft starting or soft stopping performance.

The FLC of the test motor must be at least 2% of the soft starter's minimum FLC (refer to *Minimum and Maximum Current Settings* on page 82).



#### NOTE

When testing the soft starter with a small motor, set parameter 1A *Motor Full Load Current* to the minimum allowable value.



### 4.3 Simulation Tools

Software simulation functions let you test the soft starter's operation and control circuits without connecting the soft starter to mains voltage.

- The run simulation simulates a motor starting, running and stopping to confirm that the soft starter and associated equipment have been installed correctly. Refer to *Run Simulation* on page 27 for details.
- The protection simulation simulates activation of each protection mechanism to confirm that the soft starter and associated control circuits are responding correctly. Refer to *Protection Simulation* on page 27 for details.
- The output signal simulation simulates output signalling to confirm that outputs and associated control circuits are operating correctly. Refer to *Output Signal Simulation* on page 28 for details.

The simulations are only available when the soft starter is in Ready state, control voltage is available and the keypad is active.

**NOTE**

Access to the simulation tools is protected by the security access code.  
The default access code is 0000.

## 5. Installation

### 5.1 Physical Installation

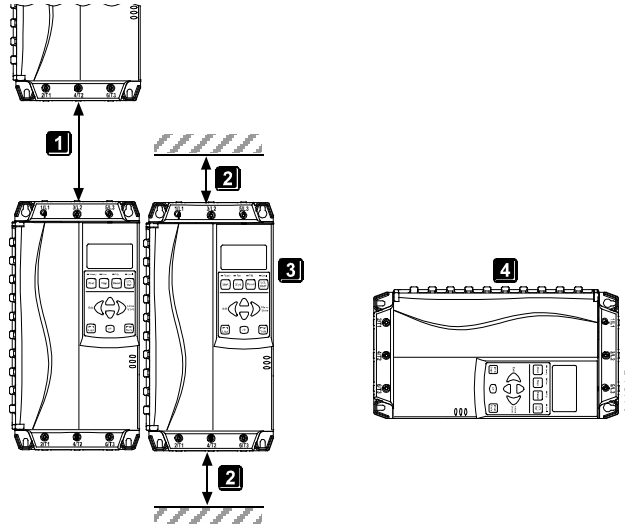

- 1 EMX3-0023B ~ EMX3-0220B: Allow 100 mm (3.94 inches) between soft starters.  
EMX3-0255B ~ EMX3-1000B: Allow 200 mm (7.88 inches) between soft starters.  
EMX3-0255C: Allow 100 mm (3.94 inches) between soft starters.  
EMX3-0360C ~ EMX3-1600C: Allow 200 mm (7.88 inches) between soft starters.
- 2 EMX3-0023B ~ EMX3-0220B: Allow 50 mm (1.97 inches) between the soft starter and solid surfaces.  
EMX3-0255B ~ EMX3-1000B: Allow 200 mm (7.88 inches) between the soft starter and solid surfaces.  
EMX3-0255C: Allow 100 mm (3.94 inches) between the soft starter and solid surfaces.  
EMX3-0360C ~ EMX3-1600C: Allow 200 mm (7.88 inches) between the soft starter and solid surfaces.
- 3 Soft starters may be mounted side by side with no clearance (that is, if mounted without communications modules).
- 4 The soft starter may be mounted on its side. Derate the soft starter's rated current by 15%.

### 5.2 Control Terminals

Control terminations use 2.5mm<sup>2</sup> plug-in terminal blocks. Unplug each block, complete the wiring, then reinsert the block.

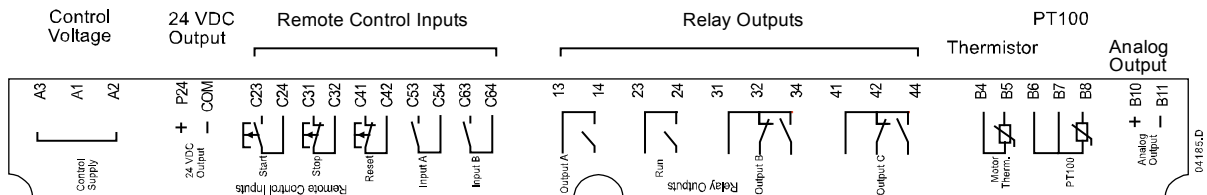

### 5.3 Control Voltage

Different models require control voltage to different terminals:

- C1 (110~210 VAC) A1, A2
- C1 (220~440 VAC) A2, A3
- C2 (24 VAC/VDC) A1, A3

## 5.4 Control Wiring

The EMX3 has three fixed inputs for remote control. These inputs should be controlled by contacts rated for low voltage, low current operation (gold flash or similar).

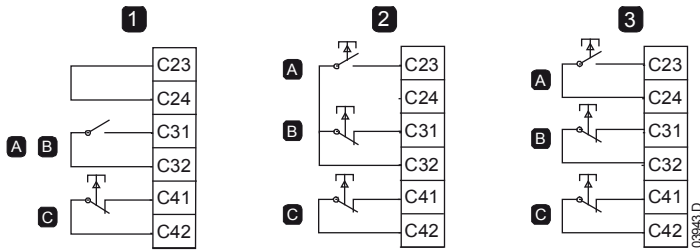

1	Two-wire control
2	Three-wire control
3	Four-wire control
A	Start
B	Stop
C	Reset



### CAUTION

The control inputs are powered by the soft starter. Do not apply external voltage to the control input terminals.

Cables to the control inputs must be segregated from mains voltage and motor cabling.

The reset input can be normally open or normally closed. Use parameter 6M to select the configuration.

## 5.5 Relay Outputs

The EMX3 provides four relay outputs, one fixed and three programmable.

The Run output closes when the soft start is complete (when the starting current falls below 120% of the programmed motor full load current) and remains closed until the beginning of a stop (either soft stop or coast to stop).

Operation of the programmable outputs is determined by the settings of parameters 7A-7I.

- If assigned to Main Contactor, the output activates as soon as the soft starter receives a start command and remains active while the soft starter is controlling the motor (until the motor starts a coast to stop, or until the end of a soft stop).
- If assigned to a trip function, the output activates when a trip occurs.
- If assigned to a flag, the output activates when the specified flag is active (parameters 7M-7O).



### CAUTION

Some electronic contactor coils are not suitable for direct switching with PCB mount relays. Consult the contactor manufacturer/supplier to confirm suitability.

Three additional outputs are available on the input/output expansion card.

## 5.6 Motor Thermistors

Motor thermistors can be connected directly to the EMX3. The soft starter will trip when the resistance of the thermistor circuit exceeds approximately 3.6 kΩ or falls below 20 Ω.

If no motor thermistors are connected to the EMX3 thermistor input terminals B4, B5 must be open. If B4, B5 are shorted, the EMX3 will trip.

The thermistor input is disabled by default, but activates automatically when a thermistor is detected. If thermistors have previously been connected to the EMX3 but are no longer required, either:

- connect a 1.2 kΩ resistor between B4, B5 or
- reset the starter to factory defaults (refer to *Load/Save Settings* on page 45). If you wish to retain the starter's configuration, save the starter's settings to a user set before resetting. Reload the settings after the thermistor input has been reset



### NOTE

The thermistor circuit should be run in screened cable and must be electrically isolated from earth and all other power and control circuits.

## 5.7 RTD/PT100

RTDs (PT100) can be connected directly to the EMX3. RTD/PT100s B ~ G are only available if the RTD/PT100 and Ground Fault expansion card is fitted.

The soft starter will trip when the temperature exceeds the value specified in parameters 11A~11G (refer to *11 RTD Temperatures*). When fitting an RTD/PT100, always review the parameter settings. The default value for each RTD/PT100 input is 50 °C.

The RTD/PT100 input is disabled by default, but activates automatically when an RTD/PT100 is detected.



### NOTE

Resistors are required on any unused RTD inputs to avoid trips from electrical fast transient (EFT) noise. When connecting an RTD, remove the resistor and associated jumper wire.

If RTD/PT100s have previously been connected to the EMX3 but are no longer required, either:

- connect a 120Ω~160Ω resistor between Signal + and Return - (B6, B8) to ensure the input remains at a known value, then adjust parameter(s) 11A~11G so that the starter does not trip or
- reset the starter to factory defaults (refer to *Load/Save Settings* on page 45). If you wish to retain the starter's configuration, save the starter's settings to a user set before resetting. Reload the settings after the RTD/PT100 input has been reset

## 5.8 Earth Terminals

Earth terminals are located at the back of the soft starter.

- EMX3-0023B ~ EMX3-0105B have one terminal on the input side (top).
- EMX3-0145B ~ EMX3-1000B and EMX3-0255C ~ EMX3-1600C have two terminals, one on the input side (top) and one on the output side (bottom).

## 5.9 Power Input and Output Configurations

### Internally Bypassed Models (EMX3-0023B~EMX3-1000B)

Models EMX3-0023B ~ EMX3-0220B have power inputs at the top of the unit and outputs at the bottom of the unit.

Internally bypassed models EMX3-0255B ~ EMX3-0425B have output busbars at the bottom of the unit and input busbars at both the top and bottom of the unit. The AC supply can be connected 'Top in, Bottom out' or 'Bottom in, Bottom out'.

Internally bypassed models EMX3-0500B ~ EMX3-1000B have input and output busbars at the top and bottom of the unit. The AC supply can be connected 'Top in, Bottom out', 'Top in, Top out', 'Bottom in, Bottom out' or 'Bottom in, Top out'.

EMX3-0023B~  
EMX3-0105B

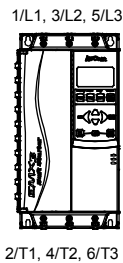

EMX3-0145B~EMX3-0220B

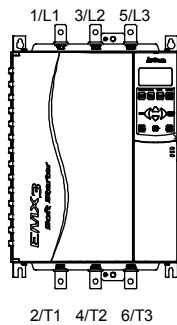

EMX3-0255B~EMX3-0425B

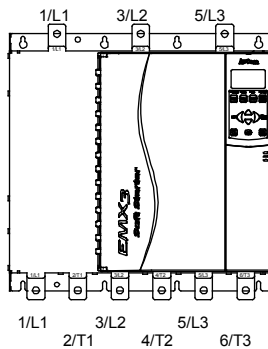

EMX3-0500B~EMX3-1000B

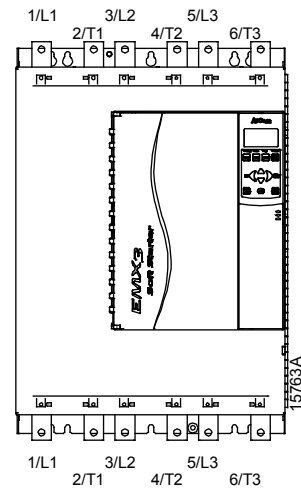

### Non-bypassed Model - EMX3-0255C

EMX3-0255C has dedicated bypass terminals at the bottom of the unit.  
The bypass terminals are T1B, T2B, T3B.

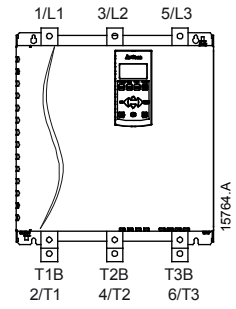

### Non-bypassed Models (EMX3-0360C~EMX3-1600C)

EMX3-0360C~EMX3-1600C have dedicated bypass terminals, on the input busbars. The bypass terminals are L1B, L2B, L3B.

The busbars on non-bypassed models EMX3-0360C ~ EMX3-1600C can be adjusted for top or bottom input and output as required.  
Refer to *Busbar Adjustment Procedure* on page 93 for step-by-step instructions. All units are manufactured bottom in/bottom out.

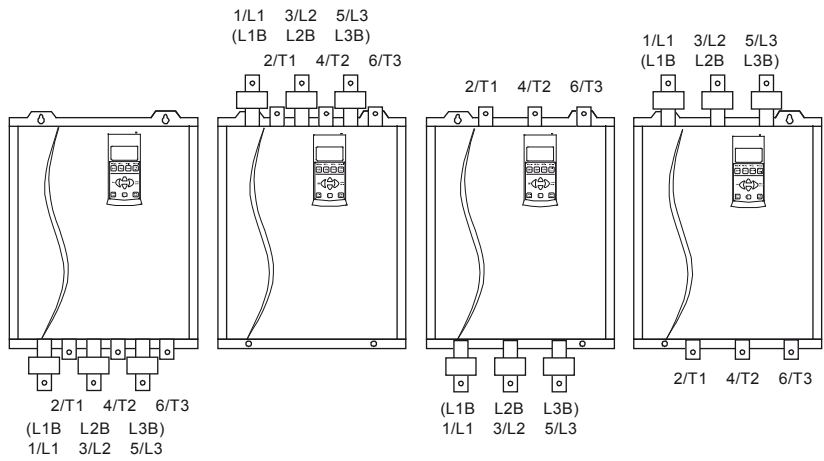

## 5.10 Power Terminations



**NOTE**

For personnel safety, the power terminals on models up to EMX3-0105B are protected by snap-off tabs. When using large cables, it may be necessary to break off these tabs.



**NOTE**

Some units use aluminium busbars. When connecting power terminations, we recommend cleaning the surface contact area thoroughly (using an emery or stainless steel brush) and using an appropriate jointing compound to prevent corrosion.

Use only copper stranded or solid conductors, rated for 75 °C or higher.

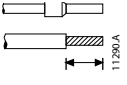
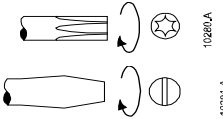
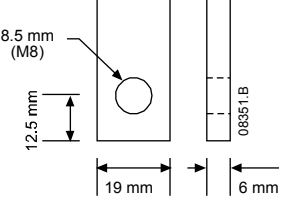
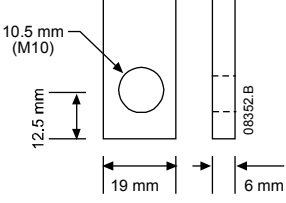
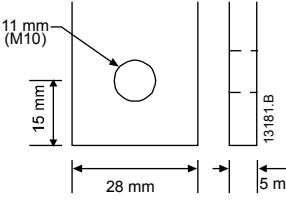
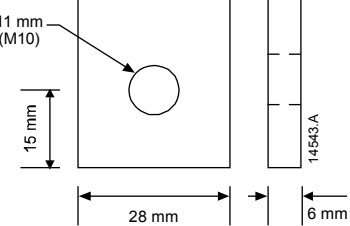
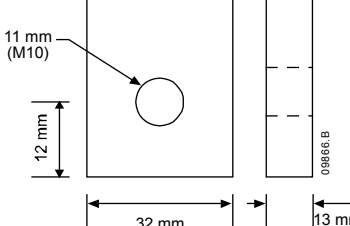
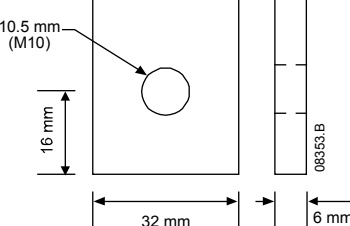
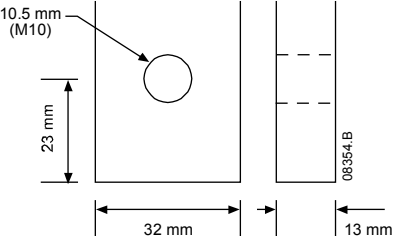
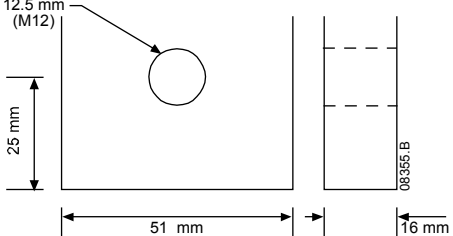
EMX3-0023B~EMX3-0105B		
 <p>Cable size: 6-50 mm<sup>2</sup> (AWG 10-1/0) Torque: 4 Nm (2.9 ft-lb)</p>	 <p>14 mm (0.55 inch)</p>	 <p>Torx T20 x 150 Flat 7 mm x 150</p>
EMX3-0145B	EMX3-0170B~EMX3-0220B	EMX3-0255B
<p>19 Nm (14.0 ft-lb)</p>  <p>8.5 mm (M8) 12.5 mm 19 mm 6 mm 08351.B</p>	<p>38 Nm (28.0 ft-lb)</p>  <p>10.5 mm (M10) 12.5 mm 19 mm 6 mm 08352.B</p>	<p>38 Nm (28.0 ft-lb)</p>  <p>11 mm (M10) 15 mm 28 mm 5 mm 13181.B</p>
EMX3-0350B~EMX3-0425B	EMX3-0500B~EMX3-1000B	EMX3-0255C
<p>38 Nm (28.0 ft-lb)</p>  <p>11 mm (M10) 15 mm 28 mm 6 mm 14543.A</p>	<p>38 Nm (28.0 ft-lb)</p>  <p>11 mm (M10) 12 mm 32 mm 13 mm 08866.B</p>	<p>38 Nm (28.0 ft-lb)</p>  <p>10.5 mm (M10) 16 mm 32 mm 6 mm 08353.B</p>
EMX3-0360C~EMX3-0930C	EMX3-1200C~EMX3-1600C	
<p>38 Nm (28.0 ft-lb)</p>  <p>10.5 mm (M10) 23 mm 32 mm 13 mm 08354.B</p>	<p>66 Nm (48.7 ft-lb)</p>  <p>12.5 mm (M12) 25 mm 51 mm 16 mm 08355.B</p>	

### 5.11 Schematic Diagrams

Internally bypassed modelsNon-bypassed models

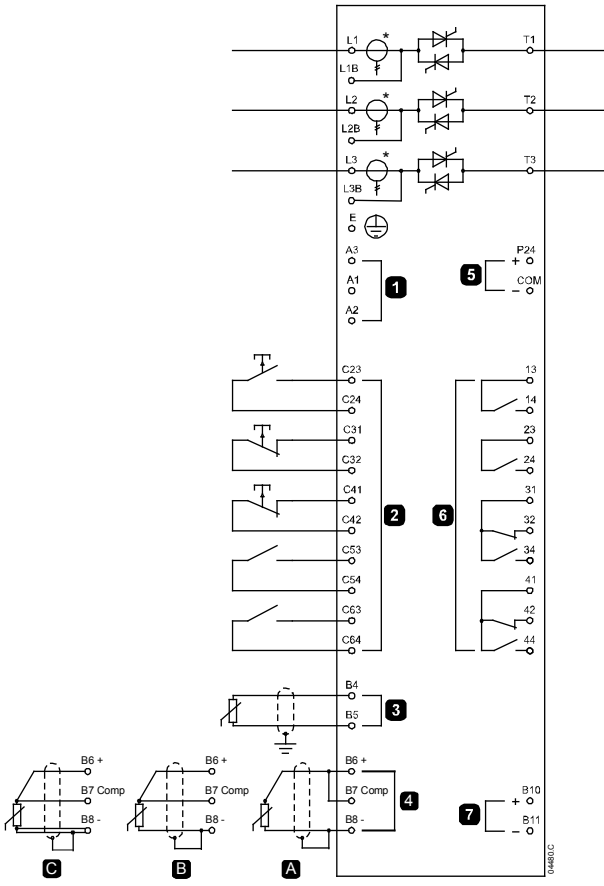
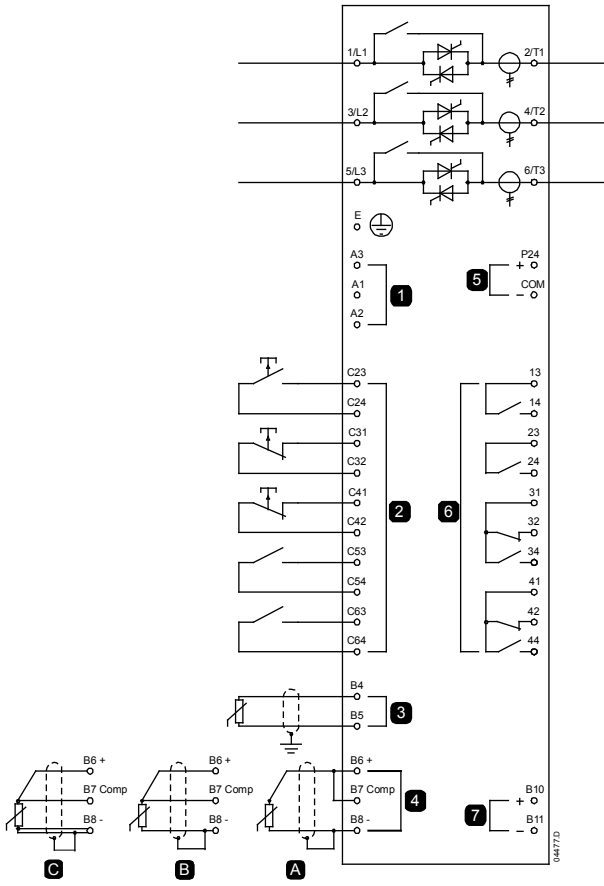

1	Control voltage (model dependent)
2	Remote control inputs
3	Motor thermistor input
4A	RTD/PT100 input - 2-wire
4B	RTD/PT100 input - 3-wire
4C	RTD/PT100 input - 4-wire
5	24 VDC output
6	Relay outputs
7	Analog output

C23, C24	Start
C31, C32	Stop
C41, C42	Reset
C53, C54	Programmable input A
C63, C64	Programmable input B
13, 14	Relay output A
23, 24	Run relay output
31, 32, 34	Relay output B
41, 42, 44	Relay output C

Different models require control voltage to different terminals:

- C1 (110~210 VAC)      A1, A2
- C1 (220~440 VAC)      A2, A3
- C2 (24 VAC/VDC)      A1, A3



**NOTE**

\* EMX3-0255C current transformers are located on the output. Bypass terminals are labelled T1B, T2B and T3B.

## 6. Power Circuits

### 6.1 Motor Connection

The EMX3 can be connected to the motor in-line or inside delta (also called three-wire and six-wire connection). When connecting in inside delta, enter the motor full load current (FLC) for parameter 1A. The EMX3 will automatically detect whether the motor is connected in-line or inside delta and will calculate the correct inside delta current level.

Models which are internally bypassed do not require an external bypass contactor.

Internally bypassed models:

EMX3-0023B, EMX3-0043B, EMX3-0050B, EMX3-0053B, EMX3-0076B, EMX3-0097B, EMX3-0100B, EMX3-0105B, EMX3-0145B, EMX3-0170B, EMX3-0200B, EMX3-0220B, EMX3-0255B, EMX3-0350B, EMX3-0425B, EMX3-0500B, EMX3-0580B, EMX3-0700B, EMX3-0820B, EMX3-0920B, EMX3-1000B

Non-bypassed models:

EMX3-0255C, EMX3-0360C, EMX3-0380C, EMX3-0430C, EMX3-0620C, EMX3-0650C, EMX3-0790C, EMX3-0930C, EMX3-1200C, EMX3-1410C, EMX3-1600C

#### In-line installation, internally bypassed

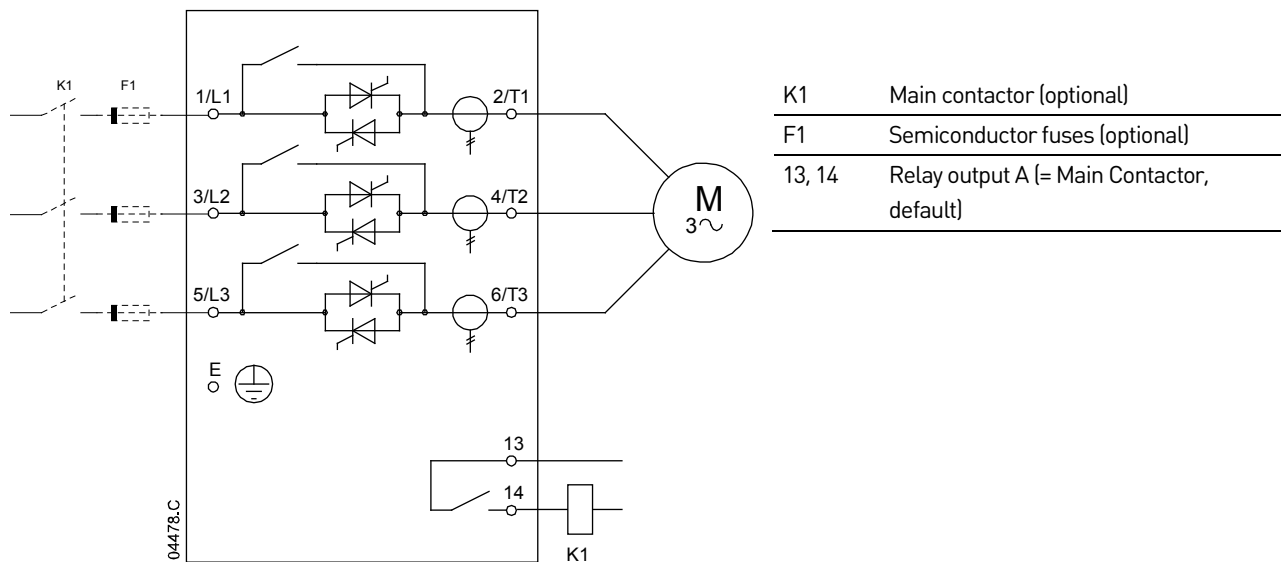



**In-line installation, externally bypassed**

Non-bypassed models have dedicated bypass terminals, which allow the EMX3 to continue providing protection and monitoring functions even when bypassed via an external bypass contactor. The bypass contactor must be connected to the bypass terminals and controlled by the soft starter's run output (terminals 23, 24).

Power connections - in-line installation, externally bypassed (EMX3-0255C)

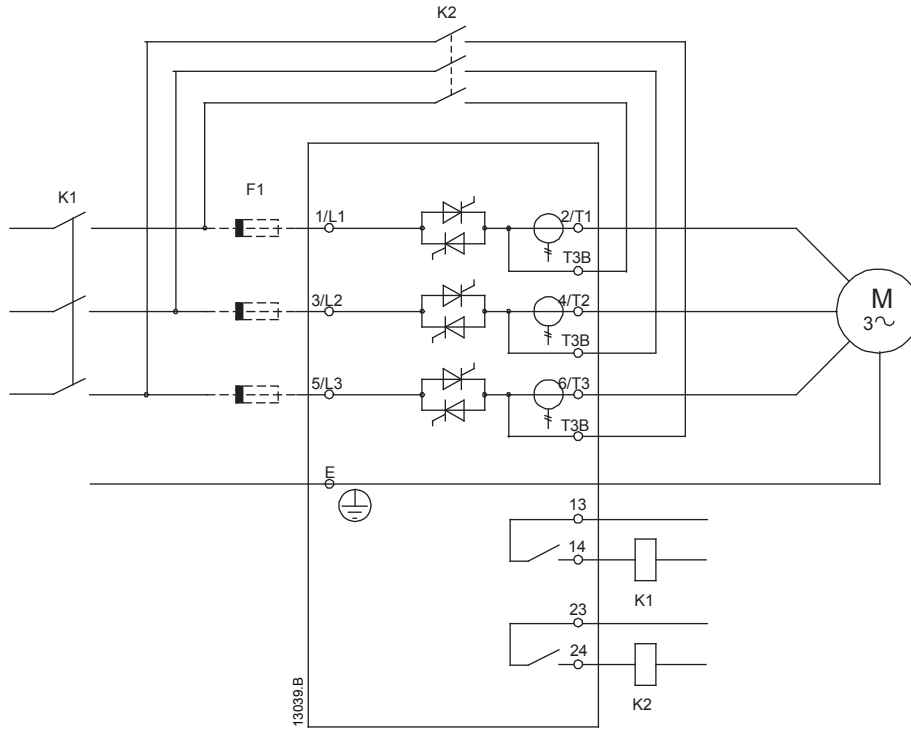

Power connections - in-line installation, externally bypassed (EMX3-0360C to EMX3-1600C)

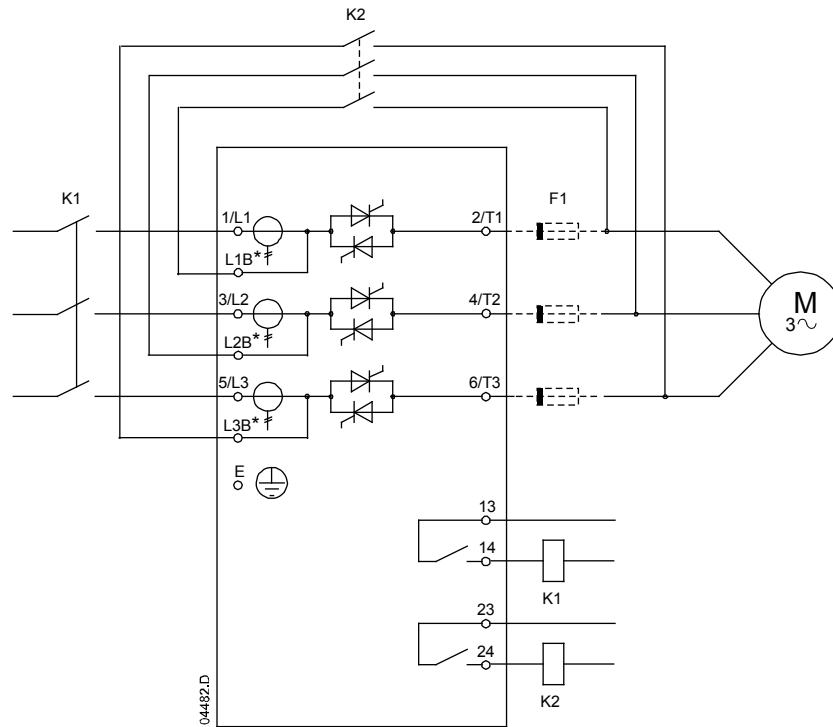

K1	Main contactor
K2	Bypass contactor (external)
F1	Semiconductor fuses (optional)

### In-line installation, non-bypassed

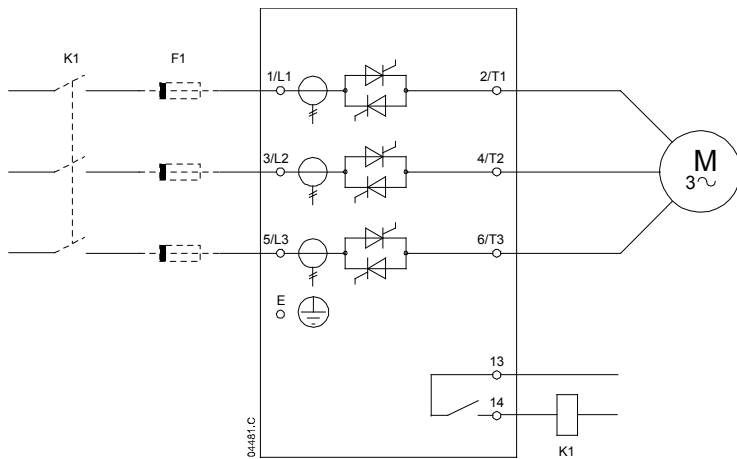

K1	Main contactor (optional)
F1	Semiconductor fuses (optional)
13, 14	Relay output A (= Main Contactor, default)

### Inside delta installation, internally bypassed

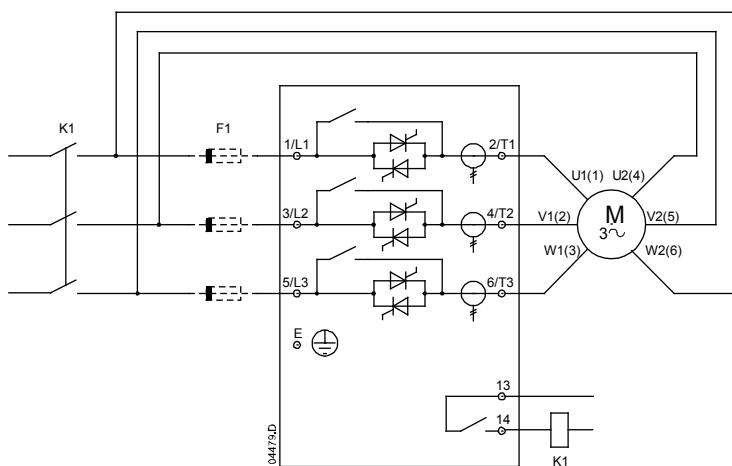

K1	Main contactor (strongly recommended)
F1	Semiconductor fuses (optional)
13, 14	Relay output A (= Main Contactor, default)



#### WARNING

When connecting the EMX3 in inside delta configuration, always install a main contactor or shunt trip circuit breaker.



#### NOTE

When connecting in inside delta, enter the motor full load current (FLC) for parameter 1A. The EMX3 will automatically detect whether the motor is connected in-line or inside delta and will calculate the correct inside delta current level.

### Inside delta installation, externally bypassed

Non-bypassed models have dedicated bypass terminals, which allow the EMX3 to continue providing protection and monitoring functions even when bypassed via an external bypass contactor. The bypass contactor must be connected to the bypass terminals and controlled by the soft starter's run output (terminals 23, 24).

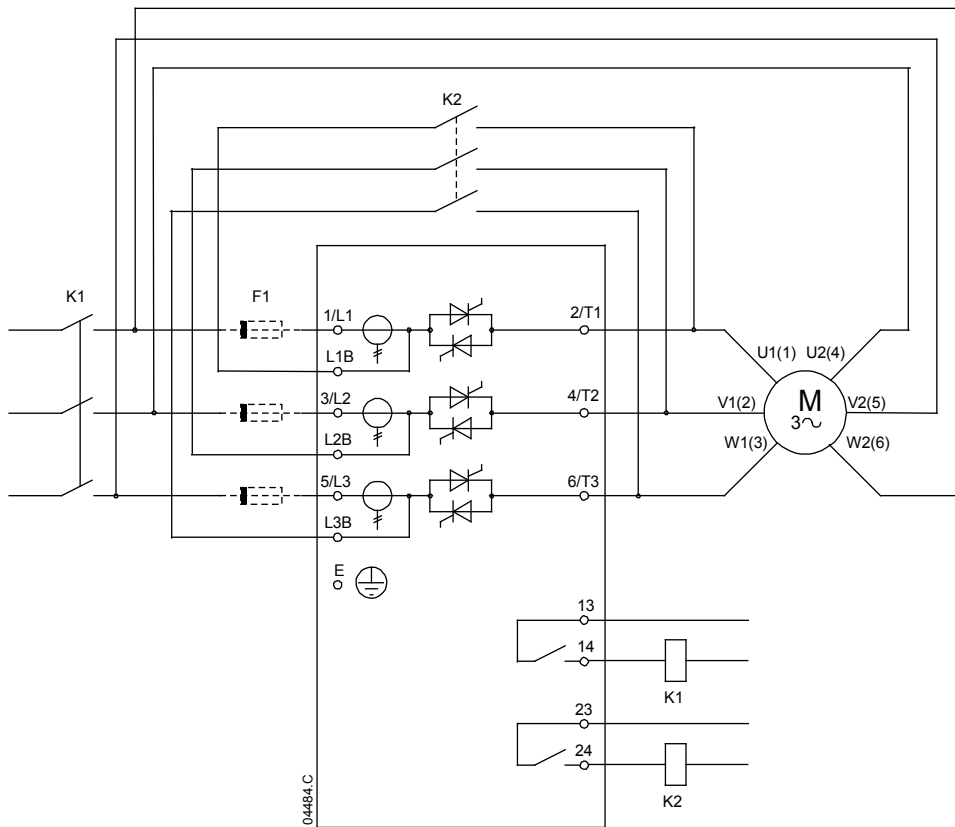

K1	Main contactor (strongly recommended)
K2	Bypass contactor (external)
F1	Semiconductor fuses (optional)
13, 14	Relay output A (= Main Contactor, default)
23, 24	Run relay output

### Inside delta installation, non-bypassed

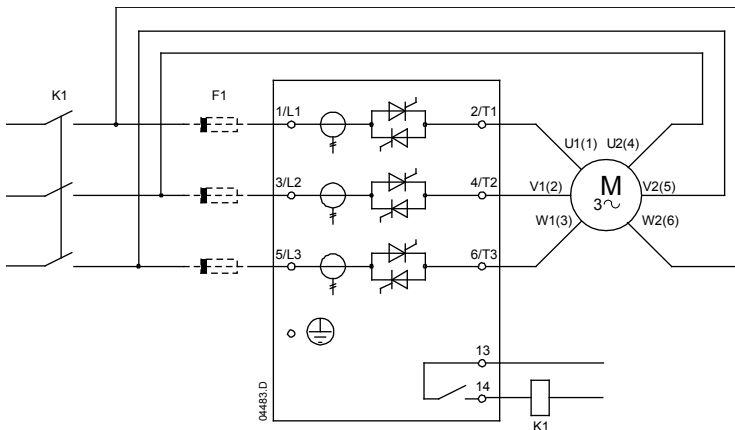

K1	Main contactor (strongly recommended)
F1	Semiconductor fuses (optional)
13, 14	Relay output A (= Main Contactor, default)

## 6.2 Bypass Contactor

Some EMX3 soft starters are internally bypassed and do not require an external bypass contactor.

Non-bypassed soft starters may be installed with an external bypass contactor. Select a contactor with an AC1 rating greater than or equal to the full load current rating of the connected motor.

Internally bypassed models:

EMX3-0023B, EMX3-0043B, EMX3-0050B, EMX3-0053B, EMX3-0076B, EMX3-0097B, EMX3-0100B, EMX3-0105B, EMX3-0145B, EMX3-0170B, EMX3-0200B, EMX3-0220B, EMX3-0255B, EMX3-0350B, EMX3-0425B, EMX3-0500B, EMX3-0580B, EMX3-0700B, EMX3-0820B, EMX3-0920B, EMX3-1000B

Non-bypassed models:

EMX3-0255C, EMX3-0360C, EMX3-0380C, EMX3-0430C, EMX3-0620C, EMX3-0650C, EMX3-0790C, EMX3-0930C, EMX3-1200C, EMX3-1410C, EMX3-1600C

## 6.3 Main Contactor

A main contactor must be installed if the EMX3 is connected to the motor in inside delta format and is optional for in-line connection. Select a contactor with an AC3 rating greater than or equal to the full load current rating of the connected motor.

## 6.4 Circuit Breaker

A shunt trip circuit breaker may be used instead of a main contactor to isolate the motor circuit in the event of a soft starter trip. The shunt trip mechanism must be powered from the supply side of the circuit breaker or from a separate control supply.

## 6.5 Power Factor Correction

If power factor correction is used, a dedicated contactor should be used to switch in the capacitors.

To use the EMX3 to control power factor correction, connect the PFC contactor to a programmable relay set to Run. When the motor reaches full speed, the relay will close and power factor correction will be switched in.



### CAUTION

Power factor correction capacitors must be connected to the input side of the soft starter. Connecting power factor correction capacitors to the output side will damage the soft starter.

## 6.6 Short Circuit Protection Devices (SCPD)

Fuses may be installed to protect the soft starter or the installation.

### Type 1 Coordination

Type 1 coordination requires that, in the event of a short circuit on the output side of a soft starter, the fault must be cleared without risk of injury to personnel. There is no requirement that the soft starter must remain operational after the fault.

HRC fuses (such as Ferraz/Mersen AJT fuses) can be used for Type 1 coordination according to IEC 60947-4-2 standard.

### Type 2 Coordination

Type 2 coordination requires that in the event of a short circuit on the output side of a soft starter, the fault must be cleared without risk of injury to personnel or damage to the soft starter.

Semiconductor fuses for Type 2 circuit protection are additional to HRC fuses or MCCBs that form part of the motor branch circuit protection.



### CAUTION

Adaptive Control controls the motor's speed profile, within the programmed time limit. This may result in a higher level of current than traditional control methods.



### CAUTION

DC Brake: A high brake torque setting can result in peak currents up to motor DOL being drawn while the motor is stopping. Ensure protection fuses installed in the motor branch circuit are selected appropriately.



### CAUTION

Integral solid state short circuit protection does not provide branch circuit protection. Branch circuit protection must be provided in accordance with the National Electrical Code and any additional local codes.

## 6.7 UL Short Circuit Ratings

Short circuit current ratings (SCCR) are available for 480 VAC and 600 VAC installations.

- 480 VAC circuits

For UL compliant installation, select a fuse that meets the specified fuse class and maximum fuse rating.

- 600 VAC circuits

For UL compliant installation, the starter can be protect by either fuses or a circuit breaker as specified in the following tables.

### Fuse selection

Model	@ 480 VAC max.		@ 600 VAC			
	Short Circuit Rating	Max. Fuse Rating (A) (fuse class)	Short Circuit Rating	Ferraz/Mersen fuse, Listed J, L or RK5 Class Fuse	Ferraz/Mersen fuse, R/C semi-conductor fuses	600 V Short cct rating – 3 cycles †
EMX3-0023B		25 (J)		AJT25	A070URD30XXX0063	
EMX3-0043B		50 (J)		AJT50		
EMX3-0050B					A070URD30XXX0125	
EMX3-0053B		60 (J)	10 kA	AJT60		
EMX3-0076B		80 (J)		AJT80		Not available
EMX3-0097B					A070URD30XXX0200	
EMX3-0100B		100 (J)		AJT100		
EMX3-0105B		125 (J)		AJT125		
EMX3-0145B		150 (J)		AJT150 / RK5 200	A070URD30XXX0315	
EMX3-0170B	65 kA	175 (J)		AJT175 / RK5 200		
EMX3-0200B		200 (J)	18 kA	AJT200 / RK5 300		
EMX3-0220B		250 (J)		AJT250 / RK5 300	A070URD30XXX0450	
EMX3-0255B		350 (RK1/J)		†		18 kA –
EMX3-0350B		400 (J)		†	Not available	For 3 cycles
EMX3-0425B		450 (J)		†	A070URD33XXX0630	30 kA –
EMX3-0500B		600 (J)	30 kA	Any 600 A, Class J	A070URD33XXX0700	For 3 cycles
EMX3-0580B						
EMX3-0700B		800 (L)		Any 800 A, Class L	Not available	
EMX3-0820B			42 kA			
EMX3-0820B					A070URD33XXX1000	42 kA –
EMX3-0920B		1200 (L)		Any 1200 A, Class L		For 3 cycles
EMX3-1000B			85 kA		A070URD33XXX1400	
EMX3-0255C	65 kA	350 (RK1/J)	18 kA	AJT300	A070URD30XXX0450	
EMX3-0360C		600 (L)		Any 600 A, Class L	A070URD33XXX0630	
EMX3-0380C					A070URD33XXX0700	
EMX3-0430C	100 kA	800 (L)	100 kA	Any 800 A, Class L		
EMX3-0620C					A070URD33XXX1000	Not available
EMX3-0650C		1200 (L)		Any 1200 A, Class L		
EMX3-0790C					A070URD33XXX1400	
EMX3-0930C						
EMX3-1200C		1600 (L)		A4BQ1600	A065URD33XXX1800	
EMX3-1410C	65 kA	2000 (L)	85 kA	A4BQ2000	A055URD33XXX2250	
EMX3-1600C				A4BQ2500		

XXX = blade type. Refer to Ferraz/Mersen catalog for details.

† - Models provided with a "3 cycle rating" are suitable for use in a circuit with the prospective current noted, when protected by any UL Listed fuses or UL Listed circuit breakers sized according to the NEC.

**Circuit breaker selection**

Model	Short Circuit Rating @ 480 VAC max.	Breaker 1: Eaton Part Number (rating, A)	Breaker 2: GE Part Number (rating, A)	Breaker 3: LSIS Part Number (rating, A)	480 V/ 600 V standard short circuit rating
EMX3-0023B		FXD3050 (50)	SELA36A7030 (50)	UTS125HU (50)	
EMX3-0043B		HFD3100 (100)		UTS150HU (100)	
EMX3-0050B				UTS150HU/ UTS250HU (150)	
EMX3-0053B		HFD3125 (125)	SELA36AT0100 (100)		10 kA
EMX3-0076B				UTS150HU/	
EMX3-0097B				UTS250HU (250)	
EMX3-0100B		HJD3250 (250)	SELA36AT0150 (150)		
EMX3-0105B		HJD3150 (250)			
EMX3-0145B					
EMX3-0170B	65 kA	HJD3250 (250)	SFLA36AT0250 (250)	UTS250HU/ UTS400HU (400)	
EMX3-0200B					
EMX3-0220B					18 kA
EMX3-0255B		HLD3600 (400)	SGLA36AT3600 (400)	UTS400HU/ UTS600HU (400)	
EMX3-0350B		HLD3600 (600)	SGLA36AT3600 (600)	UTS800HU/	
EMX3-0425B				UTS600HU (800)	
EMX3-0500B		CHLD3600 (600)	SKLA3600AT600 (600)	UTS800xU (800)	30 kA
EMX3-0580B		CHLD3800 (800)	SKLA3600AT800 (800)		
EMX3-0700B					
EMX3-0820B		NGH312033E (1200)	SKLA36AT1200 (1200)	UTS1200xU (1200)	42 kA
EMX3-0920B					
EMX3-1000B				UTS800xU (1200)	
EMX3-0255C			SGLA36AT600 (400)	UTS250HU/ UTS400HU (000)	
EMX3-0360C			SGLA36AT600 (1000)	UTS600HU/	18 kA
EMX3-0380C			SGLA36AT800 (1000)	UTS800HU (1000)	
EMX3-0430C	65 kA	Not suitable		UTS600HU/ UTS800HU/ UTS1200HU (1200)	30 kA
EMX3-0620C			SGLA36AT800 (1200)		
EMX3-0650C				UTS800/ UTS1200 (1200)	42 kA
EMX3-0790C			SKLA36AT1200		
EMX3-0930C			(1200)	UTS1200 (1200)	
EMX3-1200C					
EMX3-1410C	85 kA		<b>Siemens:</b> HPX3R1600 (1600)		85 kA
EMX3-1600C					

## 6.8 Fuse Selection for Type 2 Coordination

Type 2 coordination is achieved by using semiconductor fuses. These fuses must be able to carry motor start current and have a total clearing  $I^2t$  less than the  $I^2t$  of the soft starter SCRs.

When selecting semiconductor fuses for EMX3, use the  $I^2t$  values in the table.

For further information on selecting semiconductor fuses, contact your local distributor.

$I^2t$  values for Type 2 coordination

Model	SCR $I^2t$ (A <sup>2</sup> s)
EMX3-0023B	1150
EMX3-0043B	8000
EMX3-0050B	10500
EMX3-0053B	
EMX3-0076B	15000
EMX3-0097B	51200
EMX3-0100B	80000
EMX3-0105B	
EMX3-0145B	125000
EMX3-0170B	
EMX3-0200B	320000
EMX3-0220B	
EMX3-0255B	
EMX3-0350B	202000
EMX3-0425B	320000
EMX3-0500B	
EMX3-0580B	781000
EMX3-0700B	
EMX3-0820B	1200000
EMX3-0920B	
EMX3-1000B	2530000
EMX3-0255C	
EMX3-0360C	320000
EMX3-0380C	
EMX3-0430C	
EMX3-0620C	1200000
EMX3-0650C	
EMX3-0790C	2530000
EMX3-0930C	
EMX3-1200C	4500000
EMX3-1410C	6480000
EMX3-1600C	12500000

## 7. Keypad and Feedback

### 7.1 The Keypad

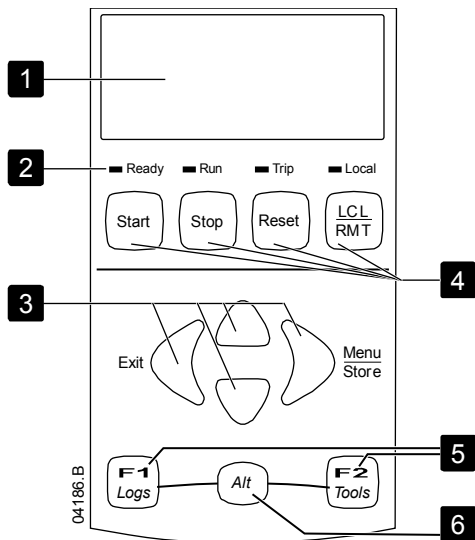

1	Four-line display for status and programming details.
2	Status LEDs
3	Menu navigation buttons: ◀ : Exit the menu or parameter, or cancel a parameter change. ▶ : Enter a menu or parameter, or save a parameter change. ▲ / ▼ : Scroll to the next or previous menu or parameter, or change the setting of the current parameter.
4	Soft starter local control buttons
5	Shortcut buttons for quick access to common tasks.
6	Alt button. Use with F1 or F2 to open performance logs or commissioning tools.

### Starter Status LEDs

LED name	On	Flashing
Ready	The motor is stopped and the starter is ready to start.	The motor is stopped and the starter is waiting for the <i>Restart Delay</i> (parameter 4M) or <i>Motor Temperature Check</i> (parameter 4N).
Run	The motor is in run state (receiving full voltage).	The motor is starting or stopping.
Trip	The starter has tripped.	The starter is in warning state.
Local	The starter is in Local control mode.	-

If the starter is in remote control mode, the Local LED will be off.

If all LEDs are off, the starter is not receiving control voltage.

### Removing and Replacing the Keypad

The keypad can be removed from the soft starter and mounted remotely on a panel using the remote mounting kit.



#### NOTE

The keypad can be removed or replaced while the starter is running. It is not necessary to remove mains or control voltage.

#### • Removing the keypad

The keypad is attached to the body of the soft starter by a DB9 serial connector and two screws. The screws are concealed behind a snap-on faceplate.

To remove the keypad:

1. Models EMX3-0023B to EMX3-1000B: open the EMX3's door.  
Models EMX3-0255C to EMX3-1600C: remove the EMX3's front cover.
2. Insert a small screwdriver under the faceplate, at the base of the keypad, and use the screwdriver to lever the faceplate off the keypad.
3. Lift the faceplate off completely.
4. Remove the two screws holding the keypad in place.
5. Lift the keypad gently off the soft starter. Pull the keypad forwards, to avoid damaging the DB9 connector.



## • Reattaching the keypad

To reattach the keypad:

1. Align the connector on the back of the keypad with the socket on the soft starter and push the keypad firmly into place. The keypad will be held in place by the connector and two locating nibs in the top right and bottom left corners. For temporary installation (eg during commissioning) it is not necessary to screw the keypad in place.
2. Replace the two screws holding the keypad in place.
3. Slide the bottom edge of the faceplate over the body of the keypad, then swing the top edge of the faceplate into place and press onto the keypad. The retaining tabs on the back of the faceplate will snap into place.

## • Synchronising the Keypad and the Starter

When a keypad is connected to an EMX3, it synchronises its parameter settings with the settings in the soft starter.

Every time a different keypad is plugged into the starter, an acknowledgement is displayed.

**New Display Detected**

Select the required option using the ▲ and ▼ buttons. Press STORE to proceed with the selection.

**Copy Parameters  
Display to Starter  
Starter to Display**

If any of the settings in the keypad are not valid for the starter, the keypad loads the default values.

## 7.2 Displays

The keypad displays a wide range of performance information about the soft starter. The top half of the screen shows real-time information on current or motor power (as selected in parameter 8D). Use the ▲ and ▼ buttons to select the information shown on the bottom half of the screen.

- Starter status
- Motor temperature
- Current
- Motor power
- Last start information
- Date and time
- SCR conduction



### NOTE

Screens shown here are with the default settings.

## Starter Status

The starter status screen shows details of the starter's operating status, motor temperature and motor power.

**Ready**  
**M1 000%**                      **000.0kW**

## Programmable screen

The EMX3's user-programmable screen can be configured to show the most important information for the particular application. Use parameters 8E to 8H to select which information to display.

**Ready**  
**0000 hrs**                      **-- %**

## Motor Temperature

The temperature screen shows which motor data set is in use, and the temperature of both motors as a percentage of total thermal capacity. If the EMX3 is configured for use on one motor, the temperature for the secondary motor (M2) will always show 0%.

**Primary Motor Set**  
 ▶ **M1 000%**                      **M2 000%**

## Current

The current screen shows real-time line current on each phase. If the RTD/PT100 and ground fault protection card is fitted, the screen will also show ground current.

Phase Currents		
000.0A	000.0A	000.0A

## Motor Power

The motor power screen shows motor power (kW, HP and kVA) and power factor.

000.0kW	0000HP
0000kVA	- . - - pf

The motor power figures are calculated using the Mains Reference Voltage (parameter 8N).

## Last Start Information

The last start information screen shows details of the most recent successful start:

- start duration (seconds)
- maximum start current drawn (as a percentage of motor full load current)
- calculated rise in motor temperature

Last start	010 s
350 % FLC $\Delta$ Temp	5%

## Date and Time

The date/time screen shows the current system date and time (24 hour format). For details on setting the date and time, refer to *Set Date and Time* on page 26.

## Performance Graph

The performance graph provides a real-time display of operating performance. Use parameters 8I-8L to select which information to display.

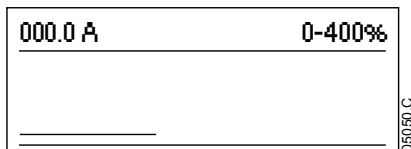

## SCR Conduction Bargraph

The SCR conduction bargraph shows the level of conduction on each phase.

L1 Cond	
L2 Cond	
L3 Cond	

## 8. Maintenance Tools

### 8.1 Testing the Installation

The EMX3 can be connected to a small motor for testing. During this test, the soft starter's control input and relay output protection settings can be tested. This test mode is not suitable for testing soft starting or soft stopping performance.

The FLC of the test motor must be at least 2% of the soft starter's minimum FLC (refer to *Minimum and Maximum Current Settings* on page 82).



#### NOTE

When testing the soft starter with a small motor, set parameter 1A *Motor Full Load Current* to the minimum allowable value.

### 8.2 Commissioning Menu (Tools)

The Commissioning Menu provides access to commissioning and testing tools.

Press **ALT** then **TOOLS** to open the Tools.

To navigate through the Commissioning Menu:

- to scroll to the next or previous item, press the ▲ or ▼ button.
- to open an item for viewing, press the ► button.
- to return to the previous level, press the ◀ button.
- to close the Commissioning Menu, press ◀ repeatedly.

### Set Date and Time

To set the date and time:

1. Press **ALT** then **TOOLS** to open the Tools.
2. Scroll to the date/time screen.
3. Press the ► button to enter edit mode.
4. Press the ► and ◀ buttons to select which part of the date or time to edit.
5. Use the ▲ and ▼ buttons to change the value.
6. To save changes, press the ► button. The EMX3 will confirm the changes.  
To cancel changes, press the ◀ button.

### Simulation Tools

Software simulation functions let you test the soft starter's operation and control circuits without connecting the soft starter to mains voltage. The EMX3 has three simulation modes:

- The run simulation simulates a motor starting, running and stopping to confirm that the soft starter and associated equipment have been installed correctly.
- The protection simulation simulates activation of each protection mechanism to confirm that the soft starter and associated control circuits are responding correctly.
- The output signal simulation simulates output signalling to confirm that outputs and associated control circuits are operating correctly.

The simulation tools are accessed via the Commissioning Menu. The simulations are only available when the soft starter is in Ready state, control voltage is available and the keypad is active.



#### NOTE

Access to the simulation tools is protected by the security access code.  
The default access code is 0000.

## Run Simulation

You can end the simulation at any time by pressing **EXIT**.

To use the run simulation:

1. Press **ALT** then **TOOLS** to open the Tools.
2. Scroll to Run Simulation and press **▶**.
3. Press **START** or activate the start input. The EMX3 simulates its pre-start checks and closes the main contactor relay. The Run LED flashes.
4. Press **▶**. The EMX3 simulates starting. The Run LED flashes.
5. Press **▶**. The EMX3 simulates running. The Run LED stays on without flashing and the bypass contactor relay closes.
6. Press **STOP** or activate the stop input. The EMX3 simulates stopping. The Run LED flashes and the bypass contactor relay opens.
7. Press **▶**. The Ready LED flashes and the main contactor relay opens.
8. Press **▶** to return to the commissioning menu.



### NOTE

If mains voltage is connected, an error message is shown. Remove mains voltage and proceed to the next step.

<b>Run Simulation Ready Apply Start Signal</b>
<b>Run Simulation Pre-Start Checks STORE to Continue</b>
<b>Run Simulation ATTENTION! Remove Mains Volts STORE to Continue</b>
<b>Run Simulation Starting X:XXs STORE to Continue</b>
<b>Run Simulation Running Apply Stop Signal</b>
<b>Run Simulation Stopping X:XXs STORE to Continue</b>
<b>Run Simulation Stopped STORE to Continue</b>

## Protection Simulation

The protection simulation simulates activation of each protection mechanism to confirm that the soft starter and associated control circuits are responding correctly.

To use the protection simulation:

1. Press **ALT** then **TOOLS** to open the Tools.
2. Scroll to Protection Simulation and press **▶**.
3. Use the **▲** and **▼** buttons to select the protection you want to simulate.
4. Press and hold **▶** to simulate the selected protection.
5. The screen is displayed momentarily. The soft starter's response depends on the Protection Action setting (parameter group 16).
6. Use **▲** or **▼** to select another simulation, or press **◀** to exit.



### NOTE

If the protection trips the soft starter, reset before simulating another protection. If the protection action is set to 'Warn and Log', no reset is required.

If the protection is set to 'Warn and Log', the warning message can be viewed only while the **▶** button is pressed.

If the protection is set to 'Log only', nothing appears on the screen but an entry will appear in the log.

<b>0.0A Tripped Selected Protection</b>
---

## Output Signal Simulation

The output signal simulation simulates output signalling to confirm that outputs and associated control circuits are operating correctly.



### NOTE

To test operation of the flags (motor temperature and low/high current), set an output relay to the appropriate function and monitor the relay's behaviour.

To use the output signal simulation:

1. Press **ALT** then **TOOLS** to open the Tools.
2. Scroll to Output Signalling Simulation and press **▶**.
3. Use the **▲** and **▼** buttons to select a function to simulate, then press **▶**.
4. Use the **▲** and **▼** buttons to turn the signal on and off.  
To confirm correct operation, monitor the state of the output.
5. Press **◀** to return to the simulation list.

**Prog Relay A**  
Off  
On

## Analog Output Simulation

The analog output simulation uses the **▲** and **▼** buttons to change the current at the analog output terminals.

**Analog Output A**  
0%  
4.0mA

Attach a current measuring device to the analog output terminals. Use the **▲** or **▼** button to adjust the percentage value on the display. The current measuring device should indicate the same level of current as shown on the display.

If the input/output expansion card is fitted, the simulation can also be used to test the operation of Relays D, E, F and Analog Output B.

## Temperature Sensors State

This screen shows the state of the motor thermistors and RTD/PT100s.

**S = Short**  
**H = Hot**  
**C = Cold**  
**O = Open**

**Temp Sensors State**  
Thermistor: 0  
RTD/PT100s: 0000000  
S = Shrt H=Hot C=Cld O=Opn

RTD/PT100s B ~ G are only available if the RTD/PT100 and Ground Fault expansion card is fitted.

## Digital I/O State

This screen shows the current status of the digital inputs and outputs.

**Digital I/O State**  
Inputs: 011000  
Outputs: 0000100

The top line of the screen shows the start, stop, reset and programmable inputs (A and B, then inputs on the I/O expansion card (if fitted)).

The bottom line of the screen shows programmable output A, the fixed Run output, programmable outputs B and C, then the outputs on the expansion card (if fitted).

## Analog I/O State

This screen shows the current status of the Analog I/O

**Analog I/O State**  
Input: ---- %  
Output A: 0-4.0mA

This screen will also show Analog Output B if the expansion card is fitted.

## Reset Thermal Models

The soft starter's thermal modelling software constantly monitors the motor's performance. This allows the starter to calculate the motor's temperature and ability to start successfully at any time. If the EMX3 is configured for use on two motors, each motor's temperature is modelled separately.

The thermal model for the active motor can be reset if required.

1. Press **ALT** then **TOOLS** to open the Tools.
2. Scroll to Reset Thermal Models and press **▶**.
3. Use **▼** to select Reset and press **STORE** to confirm.
4. When the thermal model has been reset, the screen will display a confirmation message then return to the previous screen.

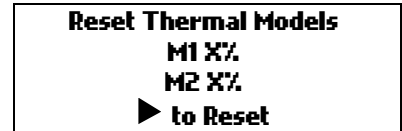

### CAUTION

Resetting the motor thermal model will compromise thermal model protection and may compromise motor life. Only reset the thermal model in an emergency.

## 8.3 Logs Menu

The Logs Menu provides information on events, trips and starter performance.

Press **ALT** then **LOGS** to open the Logs.

To navigate through the Logs Menu:

- to open a log, press the **▶** button.
- to scroll through the entries in each log, press the **▲** and **▼** buttons.
- to view details of a log entry, press the **▶** button.
- to return to the previous level, press the **◀** button.
- to close the Logs Menu, press **◀** repeatedly.

The Logs Menu can only be opened while viewing the monitoring screens.

### Trip Log

The Trip Log stores details of the eight most recent trips, including the date and time the trip happened. Trip 1 is the most recent and trip 8 is the oldest stored trip.

To open the Trip Log:

1. Press **ALT** then **LOGS** to open the Logs.
2. Scroll to Trip Log and press **▶**.
3. Use the **▲** and **▼** buttons to select a trip to view, and press **▶** to display details.

To close the log and return to the main display, press **◀** repeatedly.

### Event Log

The Event Log stores time-stamped details of the starter's 99 most recent events (actions, warnings and trips), including the date and time of the event. Event 1 is the most recent and event 99 is the oldest stored event.

To open the Event Log:

1. Press **ALT** then **LOGS** to open the Logs.
2. Scroll to Event Log and press **▶**.
3. Use the **▲** and **▼** buttons to select an event to view, and press **▶** to display details.

To close the log and return to the main display, press **◀** repeatedly.

## Performance Counters

The performance counters store statistics on the starter's operation:

- Hours run (lifetime and since counter last reset)
- Number of starts (lifetime and since counter last reset)
- Motor kWh (lifetime and since counter last reset)
- Number of times the thermal model has been reset

The resettable counters (hours run, starts and motor kWh) can only be reset if the *Adjustment Lock* (parameter 15B) is set to Read & Write.

To view the counters:

1. Press **ALT** then **LOGS** to open the Logs.
2. Scroll to counters and press **▶**.
3. Use the **▲** and **▼** buttons to scroll through the counters. Press **▶** to view details.
4. To reset a counter, press **▶** then use the **▲** and **▼** buttons to select Reset/Do Not Reset. Press **STORE** to confirm the action.

To close the counter and return to the Logs Menu, press **▶**.

## 9. Operation

### 9.1 Priority of Commands

Starter Disable overrides any other control command. Refer to parameter 6A Input A Function.

Emergency Run overrides normal control commands, including auto-start/stop. Refer to parameter 15C Emergency Run.

Auto-start/stop overrides normal control commands (local, remote or via serial communications). Refer to *3 Auto-Start/Stop* on page 48.

### 9.2 Start, Stop and Reset Commands

The soft starter can be controlled in three ways:

- using the buttons on the keypad
- via remote inputs
- via a serial communication link

The **LCL/RMT** button controls whether the EMX3 will respond to local control (via the keypad) or remote control (via the remote inputs).

- The Local LED on the keypad is on when the soft starter is in local control mode and off when the soft starter is in remote control mode.
- The Remote LED on the EMX3 is on when the soft starter is in Remote mode and off when in Local mode. The Remote LED is located on the main body of the starter (behind the keypad) and is only visible if the keypad is remotely mounted.

Control via the fieldbus communication network is always enabled in local control mode, and can be enabled or disabled in remote control mode (parameter 6R *Comms in Remote*). Control via the serial communication network requires an optional communication module.

The **STOP** button on the keypad is always enabled.

### Using the Soft Starter to Control a Motor

To soft start the motor, press the **START** button on the keypad or activate the Start remote input. The motor will start using the start mode selected in parameter 2A.

To stop the motor, press the **STOP** button on the keypad or activate the Stop remote input. The motor will stop using the stop mode selected in parameter 2H.

To reset a trip on the soft starter, press the **RESET** button on the keypad or activate the Reset remote input.

To stop the motor with a coast to stop, regardless of the setting of parameter 2H *Stop Mode*, press the local **STOP** and **RESET** buttons at the same time. The soft starter will remove power from the motor and open the main contactor, and the motor will coast to stop.

### Auto-Start/Stop

The EMX3 can also be configured to auto-start or auto-stop. Auto-start/stop operation is only available in Remote mode. In Local mode, the starter will ignore any auto-start/stop setting. To configure auto-start/stop operation, use parameters 3A-3D.



### 9.3 Soft Start Methods

Soft starters offer a variety of methods to control motor starting. Each soft start method uses a different primary control parameter.

Soft Start Method	Parameter Controlled	Performance Parameters Influenced
Timed Voltage Ramp	Voltage	Start current, start torque, acceleration
Constant Current	Current	Start torque, acceleration
Torque Control	Torque	Start current, acceleration
Adaptive Control	Acceleration	Start current, start torque

Best results are obtained by selecting the soft start method that directly controls the parameter of most importance for the application. Typically soft starters are used to limit motor start current or control load acceleration and/or deceleration. The EMX3 can be set to either Constant Current or Adaptive Control.

To Control	Use
Motor Start Current	Constant Current
Motor/Load Acceleration	Adaptive Control

#### Constant Current

Constant current is the traditional form of soft starting, which raises the current from zero to a specified level and keeps the current stable at that level until the motor has accelerated.

Constant current starting is ideal for applications where the start current must be kept below a particular level.

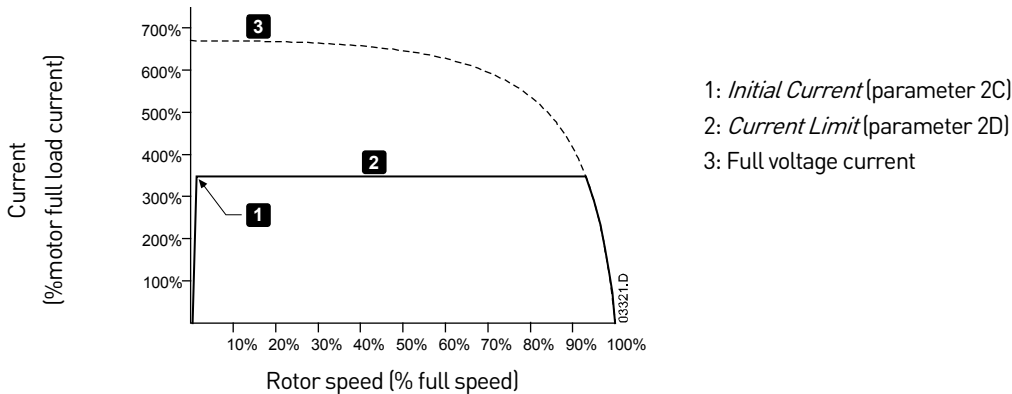

#### Current Ramp

Current ramp soft starting raises the current from a specified starting level (1) to a maximum limit (3), over an extended period of time (2).

Current ramp starting can be useful for applications where:

- the load can vary between starts (for example a conveyor which may start loaded or unloaded). Set the initial current (parameter 2C) to a level that will start the motor with a light load, and the current limit (parameter 2D) to a level that will start the motor with a heavy load.
- the load breaks away easily, but starting time needs to be extended (for example a centrifugal pump where pipeline pressure needs to build up slowly).
- the electricity supply is limited (for example a generator set), and a slower application of load will allow greater time for the supply to respond.

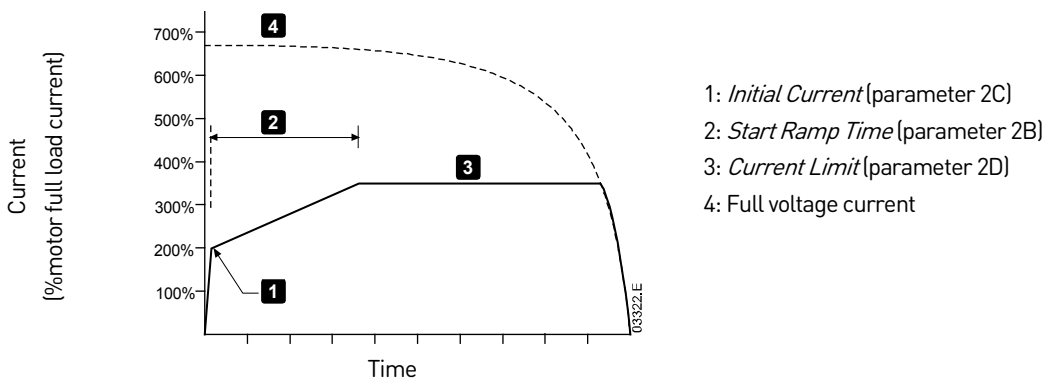

## Kickstart

Kickstart provides a short boost of extra torque at the beginning of a start, and can be used in conjunction with current ramp or constant current starting.

Kickstart can be useful to help start loads that require high breakaway torque but then accelerate easily (for example helical rotor pumps).

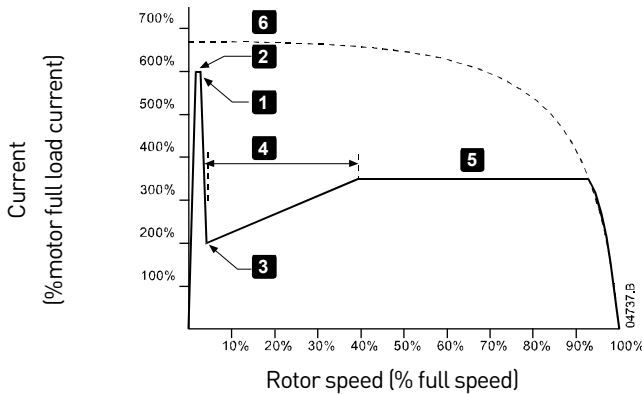

- 1: Kickstart Level (parameter 2G)
- 2: Kickstart Time (parameter 2F)
- 3: Initial Current (parameter 2C)
- 4: Start Ramp Time (parameter 2B)
- 5: Current Limit (parameter 2D)
- 6: Full voltage current

## Adaptive Control for Starting

In an adaptive control soft start, the EMX3 adjusts the current in order to start the motor within a specified time and using a selected acceleration profile.



### CAUTION

Adaptive Control cannot start the motor faster than a direct on-line (DOL) start. If the start ramp time (parameter 2B) is shorter than the motor's DOL start time, starting current may reach DOL levels.

Every application has a particular starting profile, based on characteristics of the load and the motor. Adaptive Control offers three different starting profiles, to suit the requirements of different applications. Selecting a profile that matches the inherent profile of the application can help smooth out acceleration across the full start time. Selecting a dramatically different Adaptive Control profile can somewhat neutralise the inherent profile.

The EMX3 monitors the motor's performance during each start, to improve control for future soft starts.

### • Adaptive Control

To use Adaptive Control to control starting performance:

1. Select Adaptive Control from the Start Mode menu (parameter 2A)
2. Set the desired Start Ramp Time (parameter 2B)
3. Select the desired Adaptive Start Profile (parameter 2E)
4. Set a start Current Limit (parameter 2D) sufficiently high to allow a successful start. The first Adaptive Control start will be a Constant Current start. This allows the EMX3 to learn the characteristics of the connected motor. This motor data is used by the EMX3 during subsequent Adaptive Control starts.

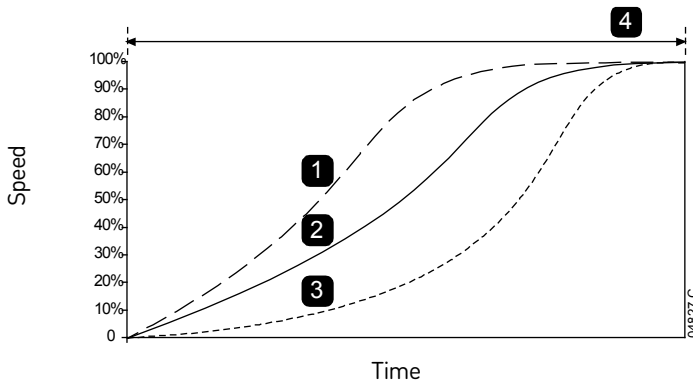

### Adaptive Start Profile (parameter 2E):

1. Early Acceleration
2. Constant Acceleration
3. Late Acceleration
4. Start Ramp Time (parameter 2B)



### NOTE

Adaptive Control will control the load according to the programmed profile. Start current will vary according to the selected acceleration profile and the programmed start time.

If replacing a motor connected to an EMX3 programmed for Adaptive Control starting or stopping, or if the starter has

been tested on a different motor prior to act  
 motor. The EMX3 will automatically re-learn the motor's characteristics if parameter 1A *Motor Full Load Current* or parameter 2K *Adaptive Control Gain* is changed.

arter will need to learn the characteristics of the new

### • How to Select the Adaptive Control Start Profile

The best profile will depend on the exact details of each application.

Some loads, such as submersible pumps, should not be run at slow speeds. An early acceleration profile will raise the speed quickly, then control acceleration through the rest of the start.



#### CAUTION

Adaptive Control controls the motor's speed profile, within the programmed time limit. This may result in a higher level of current than traditional control methods.

### • Fine-tuning Adaptive Control

If the motor does not start or stop smoothly, adjust the adaptive control gain (parameter 2K). The gain setting determines how much the EMX3 will adjust future adaptive control starts and stops, based on information from the previous start. The gain setting affects both starting and stopping performance.

- If the motor accelerates or decelerates too quickly at the end of a start or stop, increase the gain setting by 5%~10%.
- If the motor speed fluctuates during starting or stopping, decrease the gain setting slightly.



#### NOTE

Changing the gain setting resets the starter's adaptive control learning. The first start after changing the gain will use constant current.

## 9.4 Stop Methods

Soft starters offer a variety of methods for the control of motor stopping.

Stop Method	Performance Result
Coast To Stop	Natural load run down
TVR Soft Stop	Extended run down time
Adaptive Control	Extended run down time according to selected deceleration profile
Brake	Reduced run down time

Soft starters are often used in pumping applications to eliminate the damaging effects of fluid hammer. Adaptive Control should be the preferred stop method for these applications.

### Coast to Stop

Coast to stop lets the motor slow at its natural rate, with no control from the soft starter. The time required to stop will depend on the type of load.

### TVR Soft Stop

Timed voltage ramp reduces the voltage to the motor gradually over a defined time. The load may continue to run after the stop ramp is complete.

Timed voltage ramp stopping can be useful for applications where the stop time needs to be extended, or to avoid transients on generator set supplies.

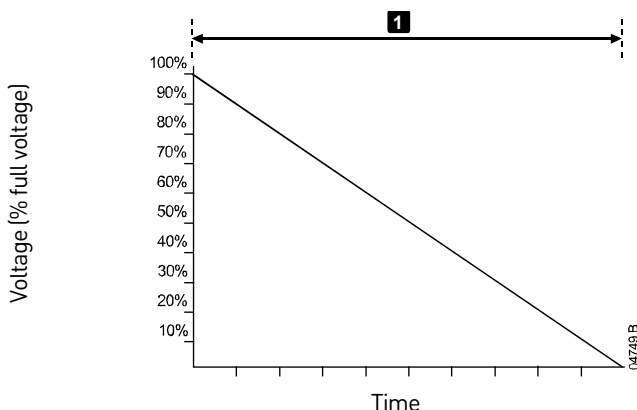

1: Stop Time (parameter 2I)

## Adaptive Control for Stopping

In an adaptive control soft stop, the EMX3 controls the current in order to stop the motor within a specified time and using a selected deceleration profile. Adaptive Control can be useful in extending the stopping time of low inertia loads.

Every application has a particular stopping profile, based on characteristics of the load and the motor. Adaptive Control offers three different stopping profiles. Choose the adaptive control profile that best matches your application requirements.



### NOTE

Adaptive control does not actively slow the motor down and will not stop the motor faster than a coast to stop. To shorten the stopping time of high inertia loads, use brake.



### CAUTION

Adaptive Control controls the motor's speed profile, within the programmed time limit. This may result in a higher level of current than traditional control methods.

## • Adaptive Control

To use Adaptive Control to control stopping performance:

1. Select Adaptive Control from the Stop Mode menu (parameter 2H)
2. Set the desired Stop Time (parameter 2I)
3. Select the required Adaptive Stop Profile (parameter 2J)

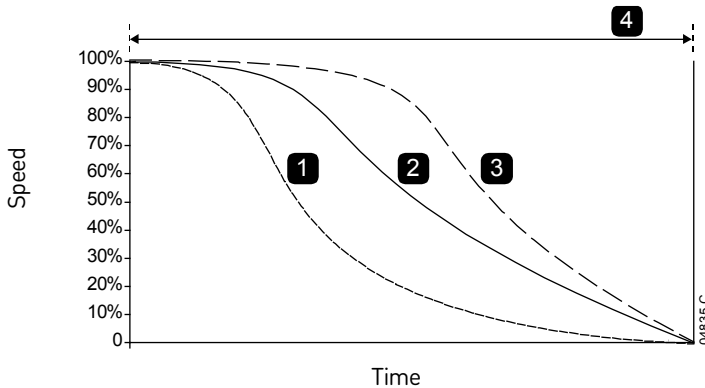

Adaptive Stop Profile (parameter 2J):

1. Early Deceleration
2. Constant Deceleration
3. Late Deceleration
4. Stop Time (parameter 2I)

The first Adaptive Control stop will be a normal soft stop. This allows the EMX3 to learn the characteristics of the connected motor. This motor data is used by the EMX3 during subsequent Adaptive Control stops.



### NOTE

Adaptive Control will control the load according to the programmed profile. Stopping current will vary according to the selected deceleration profile and stop time.

If replacing a motor connected to an EMX3 programmed for Adaptive Control starting or stopping, or if the starter has been tested on a different motor prior to actual installation, the starter will need to learn the characteristics of the new motor. The EMX3 will automatically re-learn the motor's characteristics if parameter 1A *Motor Full Load Current* or parameter 2K *Adaptive Control Gain* is changed.

## • Pump stopping

The hydraulic characteristics of pump systems vary considerably. This variation means the ideal deceleration profile and stop time will vary from application to application. The table provides guidelines on selecting between Adaptive Control deceleration profiles, but we recommend testing the three profiles to identify the best profile for the application.

Adaptive Stop Profile	Application
Late Deceleration	High head systems where even a small decrease in motor/pump speed results in a rapid transition between forward flow and reverse flow.
Constant Deceleration	Low to medium head, high flow applications where the fluid has high momentum.
Early Deceleration	Open pump systems where fluid must drain back through the pump without driving the pump in reverse.

## Brake

Brake reduces the time required to stop the motor.

During braking an increased noise level from the motor may be audible. This is a normal part of motor braking.

When brake is selected, the EMX3 uses DC injection to slow the motor.

EMX3 braking:

- Does not require the use of a DC brake contactor
- Controls all three phases so that the braking currents and associated heating are evenly distributed through the motor.



### CAUTION

If the brake torque is set too high, the motor will stop before the end of the brake time and the motor will suffer unnecessary heating which could result in damage. Careful configuration is required to ensure safe operation of the starter and motor.

A high brake torque setting can result in peak currents up to motor DOL being drawn while the motor is stopping. Ensure protection fuses installed in the motor branch circuit are selected appropriately.



### CAUTION

Brake operation causes the motor to heat faster than the rate calculated by the motor thermal model. If you are using brake, install a motor thermistor or allow sufficient restart delay (parameter 4M).

Braking has two stages:

- Pre-brake: provides an intermediate level of braking to slow motor speed to a point where full brake can be operated successfully (approximately 70% speed).
- Full brake: brake provides maximum braking torque but is ineffective at speeds greater than approximately 70%.

To configure the EMX3 for brake operation:

1. Set parameter 2I for the desired stopping time duration (1). This is the total braking time and must be set sufficiently longer than the brake time (parameter 2M) to allow the pre-braking stage to reduce motor speed to approximately 70%. If the stop time is too short, braking will not be successful and the motor will coast to stop.
2. Set Brake Time (parameter 2M) to approximately one quarter of the programmed Stop Time. This sets the time for the Full Brake stage (2).
3. Adjust the Brake Torque (parameter 2L) so that the desired stopping performance is achieved. If set too low, the motor will not stop completely and will coast to stop by the end of the braking period.

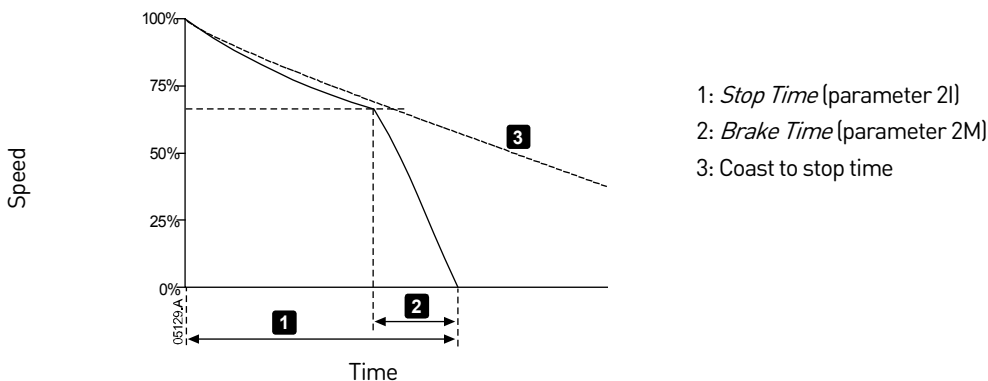

### CAUTION

When using DC brake, the mains supply must be connected to the soft starter (input terminals L1, L2, L3) in positive phase sequence and parameter 4G *Phase Sequence* must be set to Positive Only.



### NOTE

For loads which may vary between braking cycles, install a zero speed sensor to ensure that the soft starter ends DC braking when the motor stops. This avoids unnecessary heating of the motor.

For more information on using the EMX3 with an external speed sensor (eg for applications with variable load during the braking cycle), refer to *DC Brake with External Zero Speed Sensor* on page 66.

## 9.5 Jog Operation

Jog runs the motor at reduced speed, to allow alignment of the load or to assist servicing. The motor can be jogged in either forward or reverse direction.



### CAUTION

Slow speed running is not intended for continuous operation due to reduced motor cooling.

Jog operation causes the motor to heat faster than the rate calculated by the motor thermal model. If you are using jog, install a motor thermistor or allow sufficient restart delay (parameter 4M).



### NOTE

Soft start and soft stop are not available during jog operation.

Jog is only available for the primary motor.

The maximum available torque for jog forward is approximately 50%~75% of motor full load torque (FLT) depending on the motor. The torque when the motor is jogged in reverse is approximately 25% to 50% of FLT.

Parameter 15E *Jog Torque* controls how much of the maximum available jog torque the soft starter will apply to the motor.



### NOTE

Torque settings above 50% may cause increased shaft vibration.

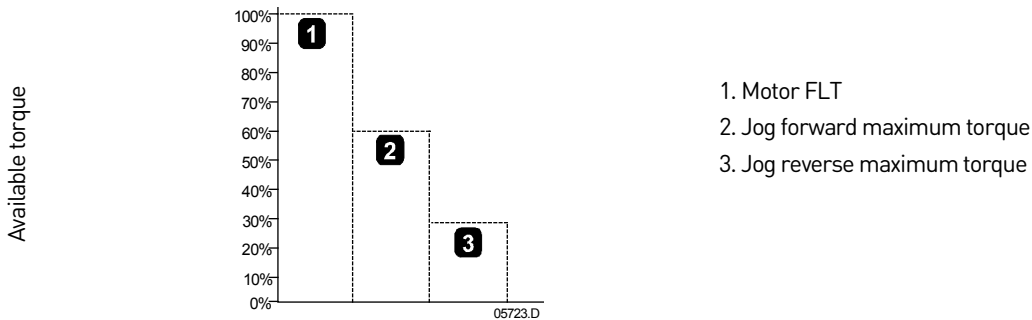

To activate jog operation, use either a programmable input (refer to parameters 6A and 6F, will operate only in Remote Mode) or a shortcut key (parameters 8B and 8C).

To stop a jog operation, perform one of the following:

- Remove the jog command.
- Press the **STOP** button on the keypad.

Jog will recommence at the end of a restart delay if the jog command is still present. All other commands except the above, will be ignored during jog operation.

## 9.6 Inside Delta Operation

Adaptive Control, Jog, Brake and PowerThrough functions are not supported with inside delta (six-wire) operation. If these functions are programmed when the starter is connected inside delta the behaviour is as given below:

Adaptive Control Start	The starter performs a constant current start.
Adaptive Control Stop	The starter performs a TVR soft stop if parameter 2I <i>Stop Time</i> is >0 secs. If parameter 2I is set to 0 secs the starter performs a coast to stop.
Jog	The starter issues a warning with the error message Unsupported Option.
Brake	The starter performs a coast to stop.
PowerThrough	The starter trips with the error message Lx-Tx Shorted.



### NOTE

When connected in inside delta, current imbalance is the only phase loss protection that is active during run. Do not disable current imbalance protection (parameter 4H) during inside delta operation.



### NOTE

When connecting in inside delta, enter the motor full load current (FLC) for parameter 1A. The EMX3 will automatically detect whether the motor is connected in-line or inside delta and will calculate the correct inside delta current level.

## 10. Programming Menu

You can access the Programming Menu at any time, including while the soft starter is running. Any changes to the start profile take effect immediately.

The Programming Menu contains four sub-menus:

<b>Quick Setup</b>	Quick Setup guides you through the parameters required to configure the EMX3 for common applications. Quick Setup suggests a value for each parameter, but you can change these as required.
<b>Standard Menu</b>	The Standard Menu provides access to commonly used parameters, allowing you to configure the EMX3 to suit your application.
<b>Extended Menu</b>	The Extended Menu provides access to all the EMX3's programmable parameters, allowing experienced users to take advantage of advanced features.
<b>Load/Save Settings</b>	Load/Save Settings lets you save the current parameter settings to a file, load parameters from a previously saved file, or reset all parameters to default values.

### 10.1 Programming Menu

The Programming Menu lets you view and change programmable parameters that control how the EMX3 operates.

To open the Programming Menu, press the **MENU** button while viewing the monitoring screens.

To navigate through the Programming Menu:

- to scroll through parameter groups, press the ▲ or ▼ button.
- to open a submenu, press the ► button.
- to view the parameters in a group, press the ► button.
- to return to the previous level, press the ◀ button.
- to close the Programming Menu, press ◀ repeatedly.

To change a parameter value:

- scroll to the appropriate parameter in the Programming Menu and press ► to enter edit mode.
- to alter the parameter setting, use the ▲ and ▼ buttons. Pressing ▲ or ▼ once will increase or decrease the value by one unit. If the button is held for longer than five seconds, the value will increase or decrease at a faster rate.
- to save changes, press **STORE**. The setting shown on the display will be saved and the keypad will return to the parameter list.
- to cancel changes, press **EXIT**. The keypad will ask for confirmation, then return to the parameter list without saving changes.

### 10.2 Adjustment Lock

You can lock the Programming Menu to prevent users from altering parameter settings. The adjustment lock can be turned on and off using parameter 15B.

To lock the programming menu:

1. Open the Programming Menu.
2. Open the Extended Menu.
3. Select 'Advanced'.
4. Enter the Access Code.
5. Select parameter 15B *Adjustment Lock*
6. Select and store 'Read Only'.

If a user attempts to change a parameter value when the adjustment lock is active, an error message is displayed:

**Access Denied**  
**Adj Lock is On**

### 10.3 Access Code

Critical parameters (parameter group 15 and higher) are protected by a four-digit security access code, preventing unauthorised users from viewing or modifying parameter settings.

When a user attempts to enter a restricted parameter group, the keypad prompts for an access code. The access code is requested once for the programming session, and authorisation continues until the user closes the menu.

To enter the access code, use the ◀ and ▶ buttons to select a digit, and the ▲ and ▼ buttons to change the value. When all four digits match your access code, press STORE. The keypad will display an acknowledgement message before continuing.

<b>Enter Access Code</b> 0###	<b>STORE</b>
<b>Access Allowed</b> <b>SUPERVISOR</b>	

To change the access code, use parameter 15A.

The simulation tools and counter resets are also protected by the security access code.

The default access code is 0000.

### 10.4 Quick Setup

The Quick Setup Menu makes it easy to configure the EMX3 for common applications. The EMX3 selects the parameters relevant to the application and suggests a typical setting, and you can adjust each parameter to suit your exact requirements.

Always set parameter 1A *Motor Full Load Current* to match the motor's nameplate full load current. The suggested value is the starter's minimum full load current.

On the display, the highlighted values are suggested values and the values indicated by a ▶ are the loaded values.

Application	Parameter	Suggested value
Pump Centrifugal	<i>Motor Full Load Current</i>	Model dependent
	<i>Start Mode</i>	Adaptive Control
	<i>Adaptive Start Profile</i>	Early Acceleration
	<i>Start Ramp Time</i>	10 seconds
	<i>Stop Mode</i>	Adaptive Control
	<i>Adaptive Stop Profile</i>	Late Deceleration
	<i>Stop Time</i>	15 seconds
Pump Submersible	<i>Motor Full Load Current</i>	Model dependent
	<i>Start Mode</i>	Adaptive Control
	<i>Adaptive Start Profile</i>	Early Acceleration
	<i>Start Ramp Time</i>	5 seconds
	<i>Stop Mode</i>	Adaptive Control
	<i>Adaptive Stop Profile</i>	Late Deceleration
	<i>Stop Time</i>	5 seconds
Fan Damped	<i>Motor Full Load Current</i>	Model dependent
	<i>Start Mode</i>	Constant Current
	<i>Current Limit</i>	350%
Fan Undamped	<i>Motor Full Load Current</i>	Model dependent
	<i>Start Mode</i>	Adaptive Control
	<i>Adaptive Start Profile</i>	Constant Acceleration
	<i>Start Ramp Time</i>	20 seconds
	<i>Excess Start Time</i>	30 seconds
	<i>Locked Rotor Time</i>	20 seconds
Compressor Screw	<i>Motor Full Load Current</i>	Model dependent
	<i>Start Mode</i>	Constant Current
	<i>Start Ramp Time</i>	5 seconds
	<i>Current Limit</i>	400%



Application	Parameter	Suggested value
Compressor Recip	<i>Motor Full Load Current</i>	Model dependent
	<i>Start Mode</i>	Constant Current
	<i>Start Ramp Time</i>	5 seconds
	<i>Current Limit</i>	450%
Conveyor	<i>Motor Full Load Current</i>	Model dependent
	<i>Start Mode</i>	Constant Current
	<i>Start Ramp Time</i>	5 seconds
	<i>Current Limit</i>	400%
	<i>Stop Mode</i>	Adaptive Control
	<i>Adaptive Stop Profile</i>	Constant Deceleration
	<i>Stop Time</i>	10 seconds
Crusher Rotary	<i>Motor Full Load Current</i>	Model dependent
	<i>Start Mode</i>	Constant Current
	<i>Start Ramp Time</i>	10 seconds
	<i>Current Limit</i>	400%
	<i>Excess Start Time</i>	30 seconds
	<i>Locked Rotor Time</i>	20 seconds
Crusher Jaw	<i>Motor Full Load Current</i>	Model dependent
	<i>Start Mode</i>	Constant Current
	<i>Start Ramp Time</i>	10 seconds
	<i>Current Limit</i>	450%
	<i>Excess Start Time</i>	40 seconds
	<i>Locked Rotor Time</i>	30 seconds

## 10.5 Standard Menu

The standard menu provides access to commonly used parameters, allowing the user to configure the EMX3 as required for the application. For details of individual parameters, refer to *Parameter Descriptions* on page 46.

	Parameter Group	Default Setting
<b>1</b>	<b>Motor Data-1</b>	
1A	<i>Motor Full Load Current</i>	Model dependent
<b>2</b>	<b>Start/Stop Modes-1</b>	
2A	<i>Start Mode</i>	Constant Current
2B	<i>Start Ramp Time</i>	10s
2C	<i>Initial Current</i>	350%
2D	<i>Current Limit</i>	350%
2H	<i>Stop Mode</i>	Coast To Stop
2I	<i>Stop Time</i>	0s
<b>3</b>	<b>Auto-Start/Stop</b>	
3A	<i>Auto-Start Type</i>	Off
3B	<i>Auto-Start Time</i>	1m
3C	<i>Auto-Stop Type</i>	Off
3D	<i>Auto-Stop Time</i>	1m
<b>4</b>	<b>Protection Settings</b>	
4A	<i>Excess Start Time</i>	20s
4C	<i>Undercurrent</i>	20%
4D	<i>Undercurrent Delay</i>	5s
4E	<i>Instantaneous Overcurrent</i>	400%
4F	<i>Instantaneous Overcurrent Delay</i>	0s
4G	<i>Phase Sequence</i>	Any Sequence

6 Inputs		
6A	Input A Function	Motor Set Select
6B	Input A Name	Input Trip
6C	Input A Trip	Always Active
6D	Input A Trip Delay	0s
6E	Input A Initial Delay	0s
6F	Input B Function	Input Trip (N/O)
6G	Input B Name	Input Trip
6H	Input B Trip	Always Active
6I	Input B Trip Delay	0s
6J	Input B Initial Delay	0s
7 Outputs		
7A	Relay A Function	Main Contactor
7B	Relay A On Delay	0s
7C	Relay A Off Delay	0s
7D	Relay B Function	Run
7E	Relay B On Delay	0s
7F	Relay B Off Delay	0s
7G	Relay C Function	Trip
7H	Relay C On Delay	0s
7I	Relay C Off Delay	0s
7M	Low Current Flag	50%
7N	High Current Flag	100%
7O	Motor Temperature Flag	80%
8 Display		
8A	Language	English
8B	F1 Button Action	Auto-Start/Stop Menu
8C	F2 Button Action	None
8D	Display A or kW	Current
8E	User Screen - Top Left	Starter State
8F	User Screen - Top Right	Blank
8G	User Screen - Bottom Left	Hours Run
8H	User Screen - Bottom Right	Analog Input

## 10.6 Extended Menu

The Extended Menu provides access to all the EMX3's programmable parameters.

	Parameter Group	Default Setting
1	Motor Data-1	
1A	Motor Full Load Current	Model dependent
1B	Locked Rotor Time	0m:10s
1C	Locked Rotor Current	600%
1D	Motor Service Factor	105%
2	Start/Stop Modes-1	
2A	Start Mode	Constant Current
2B	Start Ramp Time	10 s
2C	Initial Current	350%
2D	Current Limit	350%
2E	Adaptive Start Profile	Constant Acceleration
2F	Kickstart Time	0000ms
2G	Kickstart Level	500%

2H	Stop Mode	Coast To Stop
2I	Stop Time	0m:00s
2J	Adaptive Stop Profile	Constant Deceleration
2K	Adaptive Control Gain	75%
2L	Brake Torque	20%
2M	Brake Time	0m:01s
<b>3</b>	<b>Auto-Start/Stop</b>	
3A	Auto-Start Type	Off
3B	Auto-Start Time	00h:01m
3C	Auto-Stop Type	Off
3D	Auto-Stop Time	00h:01m
<b>4</b>	<b>Protection Settings</b>	
4A	Excess Start Time	0m:20s
4B	Excess Start Time-2	0m:20s
4C	Undercurrent	20%
4D	Undercurrent Delay	0m:05s
4E	Instantaneous Overcurrent	400%
4F	Instantaneous Overcurrent Delay	0m:00s
4G	Phase Sequence	Any Sequence
4H	Current Imbalance	30%
4I	Current Imbalance Delay	0m:03s
4J	Frequency Check	Start/Run
4K	Frequency Variation	± 5Hz
4L	Frequency Delay	0m:01s
4M	Restart Delay	10s
4N	Motor Temperature Check	Do Not Check
4O	Ground Fault Level	100 mA
4P	Ground Fault Delay	0m:03s
4Q	Reserved	-
4R	Reserved	-
4S	Reserved	-
4T	Reserved	-
<b>5</b>	<b>Auto-Reset Trips</b>	
5A	Auto-Reset Action	Do Not Auto-Reset
5B	Maximum Resets	1
5C	Reset Delay Groups A&B	00m:05s
5D	Reset Delay Group C	05 m
<b>6</b>	<b>Inputs</b>	
6A	Input A Function	Motor Set Select
6B	Input A Name	Input Trip
6C	Input A Trip	Always Active
6D	Input A Trip Delay	0m:00s
6E	Input A Initial Delay	0m:00s
6F	Input B Function	Input Trip (N/O)
6G	Input B Name	Input Trip
6H	Input B Trip	Always Active
6I	Input B Trip Delay	0m:00s
6J	Input B Initial Delay	00m:00s
6K	Input C Function	Off
6L	Input D Function	Off

6M	Remote Reset Logic	Normally Closed
6N	Analog Input Trip	Do Not Trip
6O	Analog Input Scale	2-10 V
6P	Analog Trip Point	50%
6Q	Local/Remote	LCL/RMT Anytime
6R	Comms in Remote	Enable Control in RMT
<b>7</b>	<b>Outputs</b>	
7A	Relay A Function	Main Contactor
7B	Relay A On Delay	0m:00s
7C	Relay A Off Delay	0m:00s
7D	Relay B Function	Run
7E	Relay B On Delay	0m:00s
7F	Relay B Off Delay	0m:00s
7G	Relay C Function	Trip
7H	Relay C On Delay	0m:00s
7I	Relay C Off Delay	0m:00s
7J	Relay D Function	Off
7K	Relay E Function	Off
7L	Relay F Function	Off
7M	Low Current Flag	50%
7N	High Current Flag	100%
7O	Motor Temperature Flag	80%
7P	Analog Output A	Current (% FLC)
7Q	Analog A Scale	4-20 mA
7R	Analog A Maximum Adjustment	100%
7S	Analog A Minimum Adjustment	000%
7T	Analog Output B	Current (% FLC)
7U	Analog B Scale	4-20 mA
7V	Analog B Maximum Adjustment	100%
7W	Analog B Minimum Adjustment	000%
<b>8</b>	<b>Display</b>	
8A	Language	English
8B	F1 Button Action	Auto-Start/Stop Menu
8C	F2 Button Action	None
8D	Display A or kW	Current
8E	User Screen - Top Left	Starter State
8F	User Screen - Top Right	Blank
8G	User Screen - Bottom Left	Hours Run
8H	User Screen - Bottom Right	Analog Input
8I	Graph Data	Current (% FLC)
8J	Graph Timebase	10s
8K	Graph Maximum Adjustment	400%
8L	Graph Minimum Adjustment	000%
8M	Current Calibration	100%
8N	Mains Reference Voltage	400 V
8O	Voltage Calibration	100%

<b>9</b>	<b>Motor Data-2</b>	
	9A	Dual Thermal Model Single
	9B	Motor FLC-2 Model dependent
	9C	Locked Rotor Time-2 0m:10s
	9D	Locked Rotor Current-2 600%
	9E	Motor Service Factor-2 105%
<b>10</b>	<b>Start/Stop Modes-2</b>	
	10A	Start Mode-2 Constant Current
	10B	Start Ramp-2 0m:10s
	10C	Initial Current-2 350%
	10D	Current Limit-2 350%
	10E	Adaptive Start Profile-2 Constant Acceleration
	10F	Kickstart Time-2 0000 ms
	10G	Kickstart Level-2 500%
	10H	Stop Mode-2 Coast To Stop
	10I	Stop Time-2 0m:00s
	10J	Adaptive Stop Profile-2 Constant Deceleration
	10K	Adaptive Control Gain-2 75%
	10L	Brake Torque-2 20%
	10M	Brake Time-2 0m:01s
<b>11</b>	<b>RTD Temperatures</b>	
	11A	RTD/PT100 A °C 50 °C (122 °F)
	11B	RTD/PT100 B °C 50 °C (122 °F)
	11C	RTD/PT100 C °C 50 °C (122 °F)
	11D	RTD/PT100 D °C 50 °C (122 °F)
	11E	RTD/PT100 E °C 50 °C (122 °F)
	11F	RTD/PT100 F °C 50 °C (122 °F)
	11G	RTD/PT100 G °C 50 °C (122 °F)
<b>12</b>	<b>Slip-Ring Motors</b>	
	12A	Motor Data-1 Ramp Single Ramp
	12B	Motor Data-2 Ramp Single Ramp
	12C	Changeover Time 150 ms
	12D	Slip Ring Retard 50%
<b>15</b>	<b>Advanced (Requires Access Code. Default: 0000)</b>	
	15A	Access Code 0000
	15B	Adjustment Lock Read & Write
	15C	Emergency Run Disable
	15D	Shorted SCR Action 3-Phase Control Only
	15E	Jog Torque 50%
<b>16</b>	<b>Protection Action</b>	
	16A	Motor Overload Trip Starter
	16B	Excess Start Time Trip Starter
	16C	Undercurrent Trip Starter
	16D	Instantaneous Overcurrent Trip Starter
	16E	Current Imbalance Trip Starter
	16F	Frequency Trip Starter
	16G	Input A Trip Trip Starter
	16H	Input B Trip Trip Starter
	16I	Motor Thermistor Trip Starter

16J	<i>Starter Communication</i>	Trip Starter
16K	<i>Network Communication</i>	Trip Starter
16L	<i>Heatsink Overtemperature</i>	Trip Starter
16M	<i>Battery/Clock</i>	Trip Starter
16N	<i>Ground Fault</i>	Trip Starter
16O	<i>RTD/PT100 A</i>	Trip Starter
16P	<i>RTD/PT100 B</i>	Trip Starter
16Q	<i>RTD/PT100 C</i>	Trip Starter
16R	<i>RTD/PT100 D</i>	Trip Starter
16S	<i>RTD/PT100 E</i>	Trip Starter
16T	<i>RTD/PT100 F</i>	Trip Starter
16U	<i>RTD/PT100 G</i>	Trip Starter
16V	<i>Reserved</i>	-
16W	<i>Reserved</i>	-
16X	<i>Low Control Volts</i>	Trip Starter

**20** **Restricted**  
Factory Use Only



## 10.7 Load/Save Settings

The Load/Save Settings menu requires an access code and allows users to:

- Load the EMX3's parameters with default values
- Load parameter settings from an internal file
- Save the current parameter settings to an internal file

In addition to the factory default values file, the EMX3 can store two user-defined parameter files. These files contain default values until a user file is saved.

To load or save parameter settings:

1. Open the Programming Menu.
2. Scroll to Load/Save Settings and press the  button.
3. Scroll to the required function and press the  button.
4. At the confirmation prompt, select YES to confirm or NO to cancel and then **STORE** to load/save the selection.

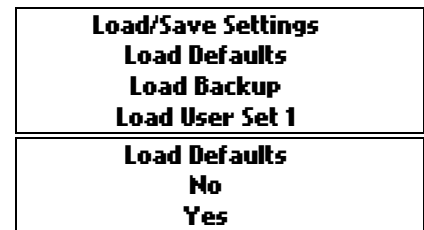

When the action has been completed, the screen will briefly display a confirmation message, then return to the status screens.



### NOTE

The saved files and current operating settings are stored in both the keypad and in the soft starter. The keypad will prompt you to synchronise the settings whenever it is plugged into a new EMX3.

## 10.8 Parameter Descriptions

### 1 Motor Data-1

The parameters in Motor Data-1 configure the soft starter to match the connected motor. These parameters describe the motor's operating characteristics and allow the soft starter to model the motor's temperature.



#### NOTE

When connecting in inside delta, enter the motor full load current (FLC) for parameter 1A. The EMX3 will automatically detect whether the motor is connected in-line or inside delta and will calculate the correct inside delta current level.

#### 1A – Motor FLC

**Range:** Model dependent

**Description:** Matches the starter to the connected motor's full load current. Set to the full load current (FLC) rating shown on the motor nameplate.

#### 1B – Locked Rotor Time

**Range:** 0:01 - 2:00 (minutes:seconds) **Default:** 10 seconds

**Description:** Sets the maximum length of time the motor can sustain locked rotor current from cold before reaching its maximum temperature. Set according to the motor datasheet.

#### 1C – Locked Rotor Current

**Range:** 400% - 1200% FLC **Default:** 600%

**Description:** Sets the locked rotor current of the connected motor, as a percentage of full load current. Set according to the motor datasheet.

#### 1D – Motor Service Factor

**Range:** 100% - 130% **Default:** 105%

**Description:** Sets the motor service factor used by the thermal model. If the motor runs at full load current, it will reach 100%. Set according to the motor datasheet.



#### NOTE

Parameters 1B, 1C and 1D determine the trip current for motor overload protection. The default settings of parameters 1B, 1C and 1D provide Motor Overload Protection: Class 10, Trip Current 105% of FLA (full load amperage) or equivalent.

### 2 Start/Stop Modes-1

#### 2A – Start Mode

**Options:** Constant Current (default)  
Adaptive Control

**Description:** Selects the soft start mode.

#### 2B – Start Ramp Time

**Range:** 1 - 180 (seconds) **Default:** 10 seconds

**Description:** Sets the total start time for an Adaptive Control start or the ramp time for current ramp starting (from the initial current to the current limit).

#### 2C – Initial Current

**Range:** 100% - 600% FLC **Default:** 350%

**Description:** Sets the initial start current level for current ramp starting, as a percentage of motor full load current. Set so that the motor begins to accelerate immediately after a start is initiated.  
If current ramp starting is not required, set the initial current equal to the current limit.

#### 2D – Current Limit

**Range:** 100% - 600% FLC **Default:** 350%

**Description:** Sets the current limit for constant current and current ramp soft starting, as a percentage of motor full load current.

## 2E – Adaptive Start Profile

**Options:** Early Acceleration  
Constant Acceleration (default)  
Late Acceleration

**Description:** Selects which profile the EMX3 will use for an Adaptive Control soft start.

## 2F – Kickstart Time

**Range:** 0 – 2000 milliseconds **Default:** 0000 milliseconds

**Description:** Sets the kickstart duration. A setting of 0 disables kickstart.

## 2G – Kickstart Level

**Range:** 100% - 700% FLC **Default:** 500%

**Description:** Sets the level of the kickstart current.



### CAUTION

Kickstart subjects the mechanical equipment to increased torque levels. Ensure the motor, load and couplings can handle the additional torque before using this feature.

## 2H – Stop Mode

**Options:** Coast To Stop (default)  
TVR Soft Stop  
Adaptive Control  
Brake

**Description:** Selects the stop mode.

## 2I – Stop Time

**Range:** 0:00 - 4:00 (minutes:seconds) **Default:** 0 seconds

**Description:** Sets the time for soft stopping the motor using timed voltage ramp or Adaptive Control. This also sets the total stopping time when using brake.  
If a main contactor is installed, the contactor must remain closed until the end of the stop time. Use one of the programmable relays to control the main contactor.

## 2J – Adaptive Stop Profile

**Options:** Early Deceleration  
Constant Deceleration (default)  
Late Deceleration

**Description:** Selects which profile the EMX3 will use for an Adaptive Control soft stop.

## 2K – Adaptive Control Gain

**Range:** 1% - 200% **Default:** 75%

**Description:** Adjusts the performance of Adaptive Control. This setting affects both starting and stopping control.



### NOTE

We recommend leaving the gain setting at the default level unless performance is not satisfactory.

If the motor accelerates or decelerates too quickly at the end of a start or stop, increase the gain setting by 5%~10%. If the motor speed fluctuates during starting or stopping, decrease the gain setting slightly.

## 2L – Brake Torque

**Range:** 20% - 100% **Default:** 20%

**Description:** Sets the amount of brake torque the EMX3 will use to slow the motor.

## 2M – Brake Time

**Range:** 1 - 30 (seconds) **Default:** 1 second

**Description:** Sets the duration for DC injection during a braking stop.



### NOTE

Parameter 2M is used in conjunction with parameter 2L. Refer to *Brake* for details.



### 3 Auto-Start/Stop

The EMX3 can be programmed to start and stop automatically, after a specified delay or at a specified time of day. Auto-start and auto-stop can be set separately.

Auto-start/stop operation is only available in Remote mode. In Local mode, the starter will ignore any auto-start/stop setting.



#### CAUTION

The auto-start timer overrides any other form of control. The motor may start without warning.



#### WARNING

This function should not be used in conjunction with remote two-wire control.

The soft starter will still accept start and stop commands from the remote inputs or serial communication network. To disable local or remote control, use parameter 6Q.

If auto-start is enabled and the user is in the menu system, auto-start will become active if the menu times out (if no keypad activity is detected for five minutes).

#### 3A – Auto-Start Type

<b>Options:</b>	Off (default)	The soft starter will not auto-start.
	Timer	The soft starter will auto-start after a delay from the next stop, as specified in parameter 3B.
	Clock	The soft starter will auto-start at the time programmed in parameter 3B.

**Description:** Selects whether the soft starter will auto-start after a specified delay, or at a time of day.

#### 3B – Auto-Start Time

**Range:** 00:01 - 24:00 (hours:minutes) **Default:** 1 minute

**Description:** Sets the time for the soft starter to auto-start, in 24 hour clock format.

#### 3C – Auto-Stop Type

<b>Options:</b>	Off (default)	The soft starter will not auto-stop.
	Timer	The soft starter will auto-stop after a delay from the next start, as specified in parameter 3D.
	Clock	The soft starter will auto-stop at the time programmed in parameter 3D.

**Description:** Selects whether the soft starter will auto-stop after a specified delay, or at a time of day.

#### 3D – Auto-Stop Time

**Range:** 00:01 - 24:00 (hours:minutes) **Default:** 1 minute

**Description:** Sets the time for the soft starter to auto-stop, in 24 hour clock format.

### 4 Protection Settings

These parameters determine when the soft starter's protection mechanisms will activate. The activation point for each protection mechanism can be set to suit the installation.

The soft starter responds to protection events by tripping, warning, or writing the event to the event log. The response is determined by the Protection Action settings. The default response is a trip.



#### CAUTION

The protection settings are vital for safe operation of the soft starter and motor. Defeating the protection may compromise the installation and should only be done in the case of emergency.

#### 4A, 4B – Excess Start Time

Excess start time is the maximum time the EMX3 will attempt to start the motor. If the motor does not transition to Run mode within the programmed limit, the starter will trip. Set for a period slightly longer than required for a normal healthy start. A setting of 0 disables excess start time protection.

**Range:** 0:00 - 4:00 (minutes:seconds) **Default:** 20 seconds

**Description:** Parameter 4A sets the time for the primary motor and parameter 4B (*Excess Start Time-2*) sets the time for the secondary motor.

#### 4C – Undercurrent

**Range:** 0% - 100% **Default:** 20%

**Description:** Sets the trip point for undercurrent protection, as a percentage of motor full load current. Set to a level between the motor's normal working range and the motor's magnetising (no load) current (typically 25% to 35% of full load current). A setting of 0% disables undercurrent protection.

#### 4D – Undercurrent Delay

**Range:** 0:00 - 4:00 (minutes:seconds) **Default:** 5 seconds

**Description:** Slows the EMX3's response to undercurrent, avoiding trips due to momentary fluctuations.

#### 4E – Instantaneous Overcurrent

**Range:** 80% - 600% FLC **Default:** 400%

**Description:** Sets the trip point for instantaneous overcurrent protection, as a percentage of motor full load current.

#### 4F – Instantaneous Overcurrent Delay

**Range:** 0:00 - 1:00 (minutes:seconds) **Default:** 0 second

**Description:** Slows the EMX3's response to overcurrent, avoiding trips due to momentary overcurrent events.

#### 4G – Phase Sequence

**Options:** Any Sequence (default)  
Positive Only  
Negative Only

**Description:** Selects which phase sequences the soft starter will allow at a start. During its pre-start checks, the starter examines the sequence of the phases at its input terminals and trips if the actual sequence does not match the selected option.

#### 4H – Current Imbalance

**Range:** 10% - 50% **Default:** 30%

**Description:** Sets the trip point for current imbalance protection.

#### 4I – Current Imbalance Delay

**Range:** 0:00 - 4:00 (minutes:seconds) **Default:** 3 seconds

**Description:** Slows the EMX3's response to current imbalance, avoiding trips due to momentary fluctuations.

#### 4J – Frequency Check

**Options:** Do Not Check  
Start Only  
Start/Run (default)  
Run Only

**Description:** Determines when and if the starter will monitor for a frequency trip.

#### 4K – Frequency Variation

**Options:** ± 2 Hz  
± 5 Hz (default)  
± 10 Hz  
± 15 Hz

**Description:** Selects the soft starter's tolerance for frequency variation.

#### 4L – Frequency Delay

**Range:** 0:01 - 4:00 (minutes:seconds) **Default:** 1 second

**Description:** Slows the EMX3's response to frequency disturbances, avoiding trips due to momentary fluctuations.



#### NOTE

If the mains frequency drops below 35 Hz or rises above 75 Hz, the starter will trip immediately.



#### CAUTION

Running a motor outside its specified frequency for long periods can cause damage and premature failure.

**4M – Restart Delay**

**Range:** 00:01 - 60:00 (minutes:seconds) **Default:** 10 seconds

**Description:** The EMX3 can be configured to force a delay between the end of a stop and the beginning of the next start. During the restart delay period, the display shows the time remaining before another start can be attempted.

**NOTE**

The restart delay is measured from the end of each stop. Changes to the restart delay setting take effect after the next stop.

**4N – Motor Temperature Check**

**Options:** Do Not Check (default)  
Check

**Description:** Selects whether the EMX3 will verify the motor has sufficient thermal capacity for a successful start. The soft starter compares the motor's calculated temperature with the temperature rise from the last motor start and only operates if the motor is cool enough to start successfully.

**4O – Ground Fault Level**

**Range:** 20 mA - 50 A (21 steps) **Default:** 100mA

**Description:** Sets the trip point for ground fault protection.

**4P – Ground Fault Delay**

**Range:** 0:01 - 4:00 (minutes:seconds) **Default:** 3 seconds

**Description:** Slows the EMX3's response to ground fault variation, avoiding trips due to momentary fluctuations.

**NOTE**

Ground fault protection is only available if the RTD/PT100 and ground fault protection card is fitted.

**4Q – Reserved**

This parameter is reserved for internal use.

**4R – Reserved**

This parameter is reserved for internal use.

**4S – Reserved**

This parameter is reserved for internal use.

**4T – Reserved**

This parameter is reserved for internal use.

**5 Auto-Reset Trips**

The EMX3 can be programmed to automatically reset certain trips, which can help minimise operating downtime. Trips are divided into three categories for auto-reset, depending on the risk to the soft starter:

Group	Trips
<b>A</b>	Current imbalance Phase Loss Power loss Frequency
<b>B</b>	Undercurrent Instantaneous overcurrent Input A trip Input B trip
<b>C</b>	Motor overload RTD/PT100 temperature trips Motor thermistor Heatsink overtemperature

Other trips cannot be automatically reset.

This function is ideal for remote installations using 2-wire auto-reset, the EMX3 will restart.

mode. If the 2-wire start signal is present after an

### 5A – Auto-Reset Action

**Options:** Do Not Auto-Reset (default)  
Reset Group A  
Reset Group A & B  
Reset Group A, B & C

**Description:** Selects which trips can be auto-reset.

### 5B – Maximum Resets

**Range:** 1 - 5 **Default:** 1

**Description:** Sets how many times the soft starter will auto-reset, if it continues to trip. The reset counter increases by one each time the soft starter auto-resets, and decreases by one after each successful start/stop cycle.

### 5C – Reset Delay Groups A&B

**Range:** 00:05 - 15:00 (minutes:seconds) **Default:** 5 seconds

**Description:** Sets the delay before resetting Group A and Group B trips.

### 5D – Reset Delay Group C

**Range:** 5 - 60 (minutes) **Default:** 5 minutes

**Description:** Sets the delay before resetting Group C trips.

## 6 Inputs

The EMX3 has two programmable inputs, which allow remote control of the soft starter. If required, two extra inputs are available on the input/output expansion card.

### 6A – Input A Function

<b>Options:</b>	Motor Set Select (default)	The EMX3 can be configured with two separate sets of motor data. To use the secondary motor data, parameter 6A must be set to 'Motor Set Select' and C53, C54 must be closed when a start command is given. The EMX3 checks which motor data to use at a start, and will use that motor data for the entire start/stop cycle.
	Input Trip (N/O)	Input A can be used to trip the soft starter. When parameter 6A is set to Input Trip (N/O), a closed circuit across C53, C54 trips the soft starter.
	Input Trip (N/C)	When parameter 6A is set to Input Trip (N/C), an open circuit across C53, C54 trips the soft starter.
	Local/Remote Select	Input A can be used to select between local and remote control, instead of using the LCL/RMT button on the keypad. When the input is open, the starter is in local mode and can be controlled via the keypad. When the input is closed, the starter is in remote mode. The START and LCL/RMT buttons are disabled, and the soft starter will ignore any Local/Remote select command from the serial communications network. To use Input A to select between local and remote control, parameter 6Q must be set to 'LCL/RMT Anytime' or 'LCL/RMT When Off'.
	Emergency Run	In emergency run the soft starter continues to run until stopped, ignoring all trips and warnings (refer to parameter 15C for details). Closing the circuit across C53, C54 activates emergency run. Opening the circuit ends emergency run and the EMX3 stops the motor.
	Starter Disable	The EMX3 can be disabled via the control inputs. An open circuit across C53, C54 will disable the starter. The EMX3 will not respond to start commands. If running, the soft starter will allow the motor to coast to stop, ignoring the soft stop mode set in parameter 2H.
	Jog Forward	Activates jog operation in a forward direction (will operate only in Remote mode).
	Jog Reverse	Activates jog operation in reverse direction (will operate only in Remote mode).

**Description:** Selects the function of Input A.

#### 6B – Input A Name

<b>Options:</b>	Input Trip (default)	No Flow
	Low Pressure	Starter Disable
	High Pressure	Controller
	Pump Fault	PLC
	Low Level	Vibration
	High Level	

**Description:** Selects a message for the keypad to display when Input A is active.

#### 6C – Input A Trip

<b>Options:</b>	Always Active (default)	A trip can occur at any time when the soft starter is receiving power.
	Operating Only	A trip can occur while the soft starter is running, stopping or starting.
	Run Only	A trip can only occur while the soft starter is running.

**Description:** Selects when an input trip can occur.

#### 6D – Input A Trip Delay

**Range:** 0:00 - 4:00 (minutes:seconds)      **Default:** 0 second

**Description:** Sets a delay between the input activating and the soft starter tripping.

#### 6E – Input A Initial Delay

**Range:** 00:00 - 30:00 (minutes:seconds)      **Default:** 0 second

**Description:** Sets a delay before an input trip can occur. The initial delay is counted from the time a start signal is received. The state of the input is ignored until the initial delay has elapsed.

#### 6F, 6G, 6H, 6I, 6J – Input B Trip

Parameters 6F–6J configure the operation of Input B, in the same way as parameters 6A–6E configure Input A. Refer to Input A for details.

- 6F *Input B Function*      **(Default:** Input Trip (N/O))
- 6G *Input B Name*      **(Default:** Input Trip)
- 6H *Input B Trip*      **(Default:** Always Active)
- 6I *Input B Trip Delay*      **(Default:** 0:00)
- 6J *Input B Initial Delay*      **(Default:** 0:00)

#### 6K, 6L – Inputs C and D

Parameters 6K and 6L select the function of Inputs C and D. Refer to parameter 6A for details.

Inputs C and D are only available if the input/output expansion card has been installed.

<b>Options:</b>	Motor Set Select
	Local/Remote Select
	Emergency Run
	Starter Disable (N/C)
	Off (default)

#### 6M – Remote Reset Logic

<b>Options:</b>	Normally Closed (default)
	Normally Open

**Description:** Selects whether the EMX3's remote reset input (terminals C41, C42) is normally open or normally closed.

### 6N – Analog Input Trip

An analog input can be fitted to the EMX3 if required. An external device can activate the analog input to trip the soft starter in response to external conditions.

**Options:** Do Not Trip (default)  
Trip High  
Trip Low

**Description:** Selects the soft starter's response to the analog input signal.

### 6O – Analog Input Scale

**Options:** 0-10 V (default)  
2-10 V

**Description:** Selects the scale of the analog input.

### 6P – Analog Trip Point

**Range:** 0% - 100% **Default:** 50%

**Description:** Sets the signal level at which an analog input trip will occur, as a percentage of the maximum signal on the input.

### 6Q – Local/Remote

<b>Options:</b>	LCL/RMT Anytime	LCL/RMT button is always enabled.
	LCL/RMT When Off	LCL/RMT button is enabled when the starter is off.
	Local Control Only	All remote inputs are disabled.
	Remote Control Only	Local control buttons ( <b>START, RESET, LCL/RMT</b> ) are disabled.

**Description:** Selects when the **LCL/RMT** button can be used to switch between local and remote control, and enables or disables the local control buttons and remote control inputs. The **STOP** button on the keypad is always enabled.



#### WARNING

The **STOP** button on the keypad is always enabled. When using two-wire remote control, the soft starter will restart if the remote start/stop and reset inputs are still active.

### 6R – Comms in Remote

**Options:** Disable Control in RMT  
Enable Control in RMT (default)

**Description:** Selects whether the starter will accept Start and Stop commands from the serial communication network when in Remote mode. The Reset and Local/Remote Control commands are always enabled.

## 7 Outputs

The EMX3 has three programmable outputs, which can be used to signal different operating conditions to associated equipment. Three additional outputs are available on the input/output expansion card.

### 7A – Relay A Function

<b>Options:</b>	Off	Relay A is not used.
	Main Contactor (default)	The relay closes when the EMX3 receives a start command, and remains closed as long as the motor is receiving voltage.
	Run	The relay closes when the starter changes to run state.
	Trip	The relay closes when the starter trips (refer to parameter 16A to 16X).
	Warning	The relay closes when the starter issues a warning (refer to parameter 16A to 16X).
	Low Current Flag	The relay closes when the low current flag activates while the motor is running (refer to parameter 7M <i>Low Current Flag</i> ).
	High Current Flag	The relay closes when the high current flag activates while the motor is running (refer to parameter 7N <i>High Current Flag</i> ).
	Motor Temperature Flag	The relay closes when the motor temperature flag activates (refer to parameter 7O <i>Motor Temperature Flag</i> ).
	Input A trip	The relay closes when Input A activates to trip the soft starter.

Input B trip	1	Input B activates to trip the soft starter.
Motor overload		The relay closes when the starter trips on Motor Overload.
Current imbalance		The relay closes when the starter trips on Current Imbalance.
Undercurrent		The relay closes when the starter trips on Undercurrent.
Instantaneous overcurrent		The relay closes when the starter trips on Instantaneous overcurrent.
Frequency		The relay closes when the starter trips on Frequency.
Ground fault		The relay closes when the starter trips on Ground Fault.
Heatsink overtemperature		The relay closes when the starter trips on Heatsink Overtemperature.
Phase Loss		The relay closes when the starter trips on Phase Loss.
Motor thermistor		The relay closes when the starter trips on Motor Thermistor.
Changeover Contactor		The relay closes when the high rotor resistance current ramp has reached full voltage, allowing use with a slip-ring motor.
Undervoltage		Not available with EMX3.
Ready		The relay is closed when the starter is in Ready state.

**Description:** Selects the function of Relay A (normally open).

#### 7B – Relay A On Delay

**Range:** 0:00 - 5:00 (minutes:seconds) **Default:** 0 second

**Description:** Sets the delay for closing Relay A.

#### 7C – Relay A Off Delay

**Range:** 0:00 - 5:00 (minutes:seconds) **Default:** 0 second

**Description:** Sets the delay for re-opening Relay A.

#### 7D~7L – Output Relays B, C, D, E, F

Parameters 7D~7L configure the operation of Relays B, C, D, E and F in the same way as parameters 7A~7C configure Relay A. Refer to *Relay A Function* for details.

Relay B is a changeover relay.

- 7D *Relay B Function* **Default:** Run
- 7E *Relay B On Delay*
- 7F *Relay B Off Delay*

Relay C is a changeover relay.

- 7G *Relay C Function* **Default:** Trip
- 7H *Relay C On Delay*
- 7I *Relay C Off Delay*

Relays D, E and F are only available if the input/output expansion card has been installed. These relays do not support on or off delays and do not support 'Changeover Contactor' function. Relay D is normally closed, relays E and F are normally open.

- 7J *Relay D Function* **Default:** Off
- 7K *Relay E Function* **Default:** Off
- 7L *Relay F Function* **Default:** Off

#### 7M – Low Current Flag

The EMX3 has low and high current flags to give early warning of abnormal operation. The current flags can be configured to indicate an abnormal current level during operation, between the normal operating level and the undercurrent or instantaneous overcurrent trip levels. The flags can signal the situation to external equipment via one of the programmable outputs.

The flags clear when the current returns within the normal operating range by 10% of the programmed flag value.

**Range:** 1% - 100% FLC **Default:** 50%

**Description:** Sets the level at which the low current flag operates, as a percentage of motor full load current.

#### 7N – High Current Flag

**Range:** 50% - 600% FLC **Default:** 100%

**Description:** Sets the level at which the high current flag operates, as a percentage of motor full load current.

### 70 – Motor Temperature Flag

The EMX3 has a motor temperature flag to give early warning of abnormal operation. The flag can indicate that the motor is operating above its normal operating temperature but lower than the overload limit. The flag can signal the situation to external equipment via one of the programmable outputs.

**Range:** 0% - 160% **Default:** 80%

**Description:** Sets the level at which the motor temperature flag operates, as a percentage of the motor's thermal capacity.

### 7P – Analog Output A

**Options:**

Current (% FLC) (default)	Current as a percentage of motor full load current.
Motor Temp (%)	Motor temperature as a percentage of the motor's thermal capacity.
Motor kW (%)	Measured motor kilowatts, as a percentage of maximum kW.
Motor kVA (%)	Measured motor kilovolt amperes, as a percentage of maximum kVA.
Motor pf	Motor power factor, measured by the soft starter.

Measured motor kW:	$\sqrt{3} \times \text{average current} \times \text{mains reference voltage} \times \text{measured power factor}$
Maximum motor kW:	$\sqrt{3} \times \text{motor FLC} \times \text{mains reference voltage}$ . Power factor is assumed to be 1
Measured motor kVA:	$\sqrt{3} \times \text{average current} \times \text{mains reference voltage}$
Maximum motor kVA:	$\sqrt{3} \times \text{motor FLC} \times \text{mains reference voltage}$

**Description:** Selects which information will be reported via the analog output.

### 7Q – Analog A Scale

**Range:** 0-20 mA  
4-20 mA (default)

**Description:** Selects the range of the analog output.

### 7R – Analog A Maximum

**Range:** 0% - 600% **Default:** 100%

**Description:** Calibrates the upper limit of the analog output to match the signal measured on an external current measuring device.

### 7S – Analog A Minimum

**Range:** 0% - 600% **Default:** 0%

**Description:** Calibrates the lower limit of the analog output to match the signal measured on an external current measuring device.

### 7T, 7U, 7V, 7W – Analog Output B

Parameters 7T-7W configure the operation of *Analog Output B*, in the same way as parameters 7P-7S configure analog output A. Refer to *Analog Output A* for details.

Output B is only available if the input/output expansion card has been installed.

## 8 Display

These parameters allow the keypad to be tailored to individual users' requirements.

### 8A – Language

**Options:**

English (default)	Português
Chinese	Français
Español	Italiano
Deutsch	Russian

**Description:** Selects which language the keypad will use to display messages and feedback.

### 8B, 8C – F1 and F2 Button Action

**Options:**

- None
- Auto-Start/Stop Menu
- Jog Forward
- Jog Reverse

**Description:** Selects the function of the F1 and F2 buttons on the keypad.





**NOTE**

The access code is not required to use the F1 and F2 buttons. Users can access these functions regardless of the setting of parameter 15B *Adjustment Lock*.

**8D – Display A or kW**

**Options:** Current (default)  
Motor kW

**Description:** Selects whether the EMX3 will display current (amperes) or motor kilowatts on the main monitoring screen.

**8E, 8F, 8G, 8H – User-Programmable Screen**

<b>Options:</b>	Blank	Displays no data in the selected area, allowing long messages to be shown without overlapping.
	Starter State (default)	The starter's operating state (starting, running, stopping or tripped). Only available for top left and bottom left positions on the screen.
	Motor Current	The average current measured on three phases.
	Motor pf	The motor's power factor, measured by the soft starter.
	Mains Frequency	The average frequency measured on three phases.
	Motor kW	The motor's running power in kilowatts.
	Motor HP	The motor's running power in horsepower.
	Motor Temp	The motor's temperature, calculated by the thermal model.
	kWh	The number of kilowatt hours the motor has run via the soft starter.
	Hours Run	The number of hours the motor has run via the soft starter.
	Analog Input	The level of analog input A (refer to parameters 6N-6P). This setting is only available if the input/output expansion option is installed.

**Description:** Selects which information will be displayed on the programmable monitoring screen.

- 8E *User Screen - Top Left* **Default:** Starter State
- 8F *User Screen - Top Right* **Default:** Blank
- 8G *User Screen - Bottom Left* **Default:** Hours Run
- 8H *User Screen - Bottom Right* **Default:** Analog Input

**8I – Graph Data**

The EMX3 has a real-time performance graph to report the behaviour of critical operating parameters.

<b>Options:</b>	Current (% FLC) (default)	Current as a percentage of motor full load current.
	Motor Temp (%)	Motor temperature as a percentage of the motor's thermal capacity.
	Motor kW (%)	Measured motor kilowatts, as a percentage of maximum kW.
	Motor kVA (%)	Measured motor kilovolt amperes, as a percentage of maximum kVA.
	Motor pf	Motor power factor, measured by the soft starter.

Measured motor kW:	$\sqrt{3} \times \text{average current} \times \text{mains reference voltage} \times \text{measured power factor}$
Maximum motor kW:	$\sqrt{3} \times \text{motor FLC} \times \text{mains reference voltage}$ . Power factor is assumed to be 1
Measured motor kVA:	$\sqrt{3} \times \text{average current} \times \text{mains reference voltage}$
Maximum motor kVA:	$\sqrt{3} \times \text{motor FLC} \times \text{mains reference voltage}$

**Description:** Selects which information the graph will display.

**8J – Graph Timebase**

<b>Options:</b>	10 seconds (default)	10 minutes
	30 seconds	30 minutes
	1 minute	1 hour
	5 minutes	

**Description:** Sets the graph time scale. The graph will progressively replace the old data with new data.

**8K – Graph Maximum**

**Range:** 0% – 600% **Default:** 400%

**Description:** Adjusts the upper limit of the performance graph.

### 8L – Graph Minimum

**Range:** 0% – 600% **Default:** 0%

**Description:** Adjusts the lower limit of the performance graph.

### 8M – Current Calibration

**Range:** 85% - 115% **Default:** 100%

**Description:** Calibrates the soft starter's current monitoring circuits to match an external current metering device. Use the following formula to determine the necessary adjustment:

$$\text{Calibration (\%)} = \frac{\text{Current shown on EMX3 display}}{\text{Current measured by external device}}$$

$$\text{eg } 102\% = \frac{66\text{A}}{65\text{A}}$$



**NOTE**

This adjustment affects all current-based functions and protections.

### 8N – Mains Reference Voltage

**Range:** 100 – 690 V **Default:** 400 V

**Description:** Sets the nominal mains voltage for the keypad's monitoring functions. This is used to calculate motor kilowatts and kilovolt amperes (kVA) but does not affect the EMX3's motor control or protection.

### 80 Reserved

**Description:** This parameter is reserved for future use.

## 9 Motor Data-2

The EMX3 can support two different starting and stopping motor data sets.

- To use the EMX3 with two separate motors (such as a duty-standby configuration), use parameter 9A to select dual thermal modelling and configure parameters 9B~9E to suit the second motor.
- To use the EMX3 with two different motor data sets for the same motor (for dual speed motors or applications where starting conditions may vary), use parameter 9A to select a single thermal model, and configure the starting and stopping profiles as required in parameters 10A~10G. The soft starter will ignore parameters 9B~9E and will use settings from the primary motor.

To select the secondary motor data set, a programmable input must be configured to parameter set selection (parameters 6A and 6F) and the input must be active when the soft starter receives a start signal.



**NOTE**

You can only choose which motor data set to use while the soft starter is stopped.

### 9A – Dual Thermal Model

**Options:** Single (default)  
Dual

**Description:** Activates dual thermal modelling. The dual thermal model is required only if the EMX3 is controlling two physically separate motors.

### 9B – Motor FLC-2

**Range:** Model dependent

**Description:** Sets the secondary motor's full load current.

### 9C – Locked Rotor Time-2

**Range:** 0:01 - 2:00 (minutes:seconds) **Default:** 10 seconds

**Description:** Sets the maximum length of time the motor can sustain locked rotor current from cold before reaching its maximum temperature. Set according to the motor datasheet.

**9D – Locked Rotor Current-2**

**Range:** 400% - 1200% FLC **Default:** 600%

**Description:** Sets the locked rotor current of the connected motor, as a percentage of full load current. Set according to the motor datasheet.

**9E – Motor Service Factor-2**

**Range:** 100% - 130% FLC **Default:** 105%

**Description:** Sets the secondary motor's service factor.

**10 Start/Stop-2****10A – Start Mode-2**

**Options:** Constant Current (default)  
Adaptive Control

**Description:** Selects the soft start mode.

**10B – Start Ramp Time-2**

**Range:** 1 - 180 (seconds) **Default:** 10 seconds

**Description:** Sets the total start time for an Adaptive Control start or the ramp time for current ramp starting (from the initial current to the current limit).

**10C – Initial Current-2**

**Range:** 100% - 600% **Default:** 350%

**Description:** Sets the initial start current level for current ramp starting, as a percentage of motor full load current. Set so that the motor begins to accelerate immediately after a start is initiated.  
If current ramp starting is not required, set the initial current equal to the current limit.

**10D – Current Limit-2**

**Range:** 100% - 600% FLC **Default:** 350%

**Description:** Sets the current limit for constant current and current ramp soft starting, as a percentage of motor full load current.

**10E – Adaptive Start Profile-2**

**Options:** Early Acceleration  
Constant Acceleration (default)  
Late Acceleration

**Description:** Selects which profile the EMX3 will use for an Adaptive Control soft start.

**10F – Kickstart Time-2**

**Range:** 0 - 2000 (milliseconds) **Default:** 0000 milliseconds

**Description:** Sets the kickstart duration. A setting of 0 disables kickstart.

**10G – Kickstart Level-2**

**Range:** 100% - 700% FLC **Default:** 500%

**Description:** Sets the level of the kickstart current.

**10H – Stop Mode-2**

**Options:** Coast To Stop (default)  
TVR Soft Stop  
Adaptive Control  
Brake

**Description:** Selects the stop mode.

**10I – Stop Time-2**

**Range:** 0:00 - 4:00 (minutes:seconds) **Default:** 0 second

**Description:** Sets the stop time.

### 10J – Adaptive Stop Profile-2

**Options:** Early Deceleration  
Constant Deceleration (default)  
Late Deceleration

**Description:** Selects which profile the EMX3 will use for an Adaptive Control soft stop.

### 10K – Adaptive Control Gain-2

**Range:** 1% - 200% **Default:** 75%

**Description:** Adjusts the performance of Adaptive Control. This setting affects both starting and stopping control.

### 10L – Brake Torque-2

**Range:** 20% - 100% **Default:** 20%

**Description:** Sets the amount of brake torque the EMX3 will use to slow the motor.

### 10M – Brake Time-2

**Range:** 1 - 30 (seconds) **Default:** 1 second

**Description:** Sets the duration for DC injection during a braking stop.

## 11 RTD Temperatures

The EMX3 has one RTD/PT100 input and can be fitted with another six PT100 inputs by using the RTD/PT100 and ground fault protection card. The inputs can trip the soft starter when the temperature exceeds a specified point, and different trip temperatures can be set for each input.

PT100 inputs B ~ G are only available if the RTD/PT100 and ground fault protection card has been installed.

**Range:** 0 - 250 ° C **Default:** 50 ° C

**Description:** Sets the trip points for the RTD/PT100 inputs.

- 11A RTD A Trip Temp
- 11B RTD B Trip Temp
- 11C RTD C Trip Temp
- 11D RTD D Trip Temp
- 11E RTD E Trip Temp
- 11F RTD F Trip Temp
- 11G RTD G Trip Temp

## 12 Slip-Ring Motors

These parameters allow the soft starter to be configured for use with a slip-ring motor.

### 12A, 12B – Motor Data-1 and Motor Data-2 Ramp

**Options:** Single Ramp (default)  
Dual Ramp

**Description:** Selects whether to use a single or dual current ramp profile for soft starting. Set to single ramp for non-slip ring induction motors, or dual ramp for slip-ring induction motors.

Parameter 12A selects the ramp configuration for the primary motor and parameter 12B selects the ramp configuration for the secondary motor.

### 12C – Changeover Time

**Range:** 100 - 500 (milliseconds) **Default:** 150 milliseconds

**Description:** Sets the delay between the rotor resistance relay closing and the low resistance current ramp starting. Set so that the contactor has enough time to close, but the motor does not slow down.

Parameter 12C only applies if parameter 12A or 12B is set to 'Dual Ramp', and an output relay is set to 'Changeover Contactor'.

**12D – Slip-Ring Retard**

**Range:** 10% - 90% **Default:** 50%

**Description:** Sets the level of conduction after the rotor resistance contactor closes, as a percentage of full conduction. Set so that no current pulse occurs, but the motor retains enough speed to start correctly.

**15 Advanced****15A – Access Code**

**Range:** 0000 - 9999 **Default:** 0000

**Description:** Sets the access code to control access to restricted sections of the menus. Use the ◀ and ▶ buttons to select which digit to alter and use the ▲ and ▼ buttons to change the value.

**NOTE**

In the event of a lost access code, contact your supplier for a master access code that allows you to re-program a new access code.

**15B – Adjustment Lock**

**Options:** Read & Write (default) Allows users to alter parameter values in the Programming Menu.  
 Read Only Prevents users altering parameter values in the Programming Menu. Parameter values can still be viewed.

**Description:** Selects whether the keypad will allow parameters to be changed via the Programming Menu.

**NOTE**

Changes to the Adjustment Lock setting take effect only after the Programming Menu has been closed.

**15C – Emergency Run**

**Options:** Disable (default)  
 Enable

**Description:** Selects whether the soft starter will permit emergency run operation. In emergency run, the soft starter will start (if not already running) and continue to operate until emergency run ends, ignoring stop commands and trips. Emergency run is controlled using a programmable input.

**CAUTION**

Continued use of Emergency Run is not recommended. Emergency Run may compromise the starter life as all protections and trips are disabled.

Using the starter in 'Emergency Run' mode will void the product warranty.

**15D – Shorted SCR Action**

**Options:** 3-Phase Control Only (default)  
 PowerThrough

**Description:** Selects whether the soft starter will allow PowerThrough operation, if the soft starter is damaged on one phase. The soft starter will use two-phase control, allowing the motor to continue operating in critical applications.

- PowerThrough is only available with in-line installations. If the starter is installed inside delta, PowerThrough will not operate.
- PowerThrough remains active until '3-Phase Control Only' is reselected.
- A shorted SCR or a short within the bypass contactor will trip the starter on 'Lx-Tx shorted'. If PowerThrough is enabled, the trip can be reset and subsequent starts will use PowerThrough two-phase control; however not all features will be available. The trip LED will flash and the display will indicate '2 Phase - Damaged SCR'.

**CAUTION**

PowerThrough uses a two-phase soft start technology and additional care is required when sizing circuit breakers and protection. Contact your local supplier for assistance.

**CAUTION**

The starter will trip on Lx-Tx Shorted on the first start attempt after control power is applied. PowerThrough will not operate if control power is cycled between starts.

PowerThrough operation does not support Adaptive current soft starting or soft stopping. In PowerThrough, the EMX3 will automatically select constant current soft starting and timed voltage ramp soft stopping. If PowerThrough is enabled, parameters 2C and 2D must be set appropriately.

### 15E – Jog Torque

The EMX3 can jog the motor at a reduced speed, which allows precise positioning of belts and flywheels. Jog can be used for either forward or reverse operation.

**Range:** 20% - 100% **Default:** 50%

**Description:** Sets the current limit for jog operation.

## 16 Protection Action

These parameters define how the soft starter will respond to different protection events. The soft starter can trip, issue a warning, or ignore different protection events as required. All protection events are written to the event log. The default action for all protections is to trip the soft starter.

Protections 16N *Ground Fault* and 16P~16U *RTD/PT100* are only available if the RTD/PT100 and ground fault protection card has been fitted.



### CAUTION

Defeating the protection may compromise the starter and motor, and should only be done in the case of emergency.

### 16A~16X – Protection Actions

**Options:** Trip Starter (default)  
Warn and Log  
Log Only

**Description:** Selects the soft starter's response to each protection.

- 16A *Motor Overload*
- 16B *Excess Start Time*
- 16C *Undercurrent*
- 16D *Instantaneous Overcurrent*
- 16E *Current Imbalance*
- 16F *Frequency*
- 16G *Input A Trip*
- 16H *Input B Trip*
- 16I *Motor Thermistor*
- 16J *Starter Communication*
- 16K *Network Communication*
- 16L *Heatsink Overtemperature*
- 16M *Battery/Clock*
- 16N *Ground Fault*
- 16O~16U *RTD A~G Overtemperature*
- 16V *Reserved*
- 16W *Reserved*
- 16X *Low Control Volts*

## 20 Restricted

These parameters are restricted for Factory use and are not available to the user.

# 11. Application Examples

## 11.1 Installation with Main Contactor

The EMX3 is installed with a main contactor (AC3 rated). Control voltage must be supplied from the input side of the contactor.

The main contactor is controlled by the EMX3 Main Contactor output, which by default is assigned to Output Relay A (terminals 13, 14).

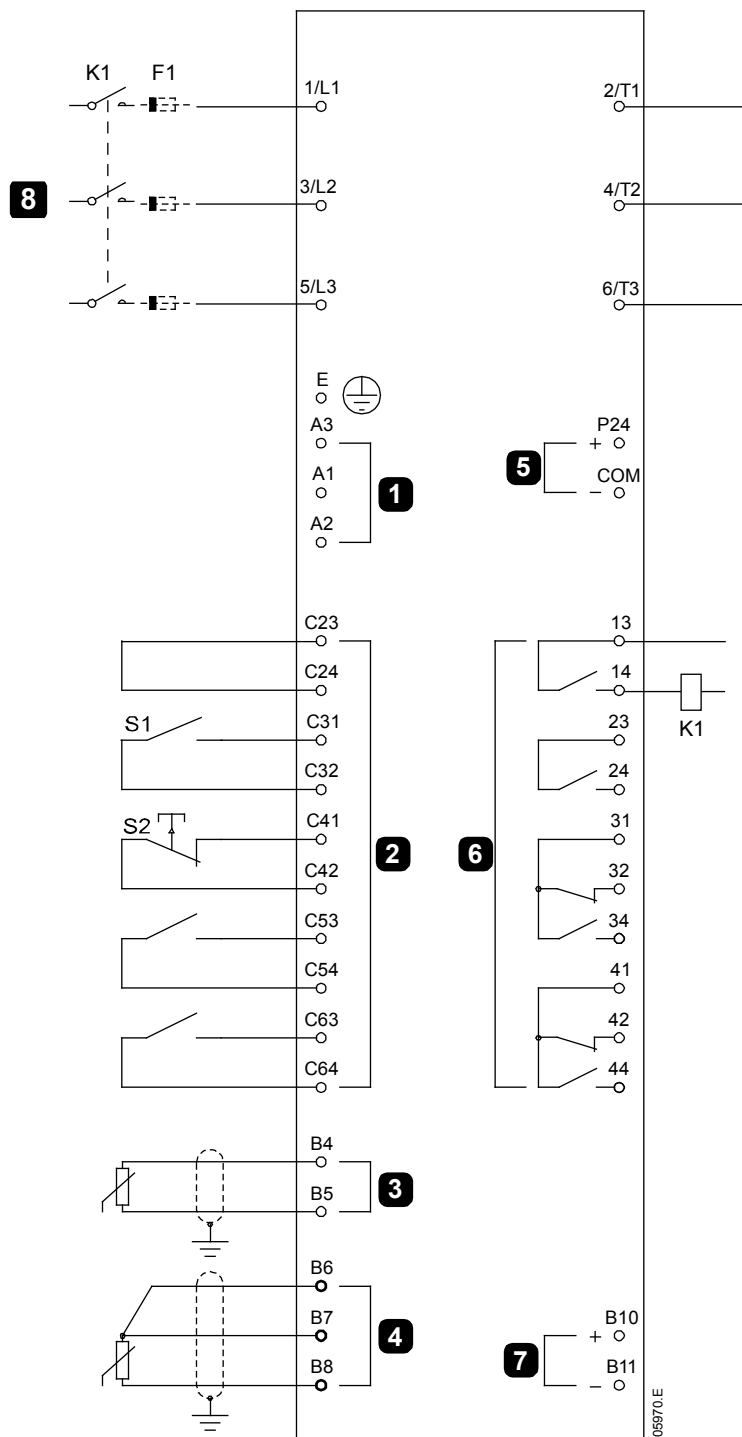

1	Control voltage (model dependent)
2	Remote control inputs
3	Motor thermistor input
4	RTD/PT100 input
5	24 VDC output
6	Relay outputs
7	Analog output
8	Three-phase supply
9	Motor terminals
K1	Main contactor
F1	Semiconductor fuses (optional)
S1	Start/stop contact
S2	Reset contact
13, 14	Relay output A
23, 24	Run relay output
31, 32, 34	Relay output B
41, 42, 44	Relay output C

Parameter settings:

- Parameter *7A Relay A Function*
  - Select 'Main Contactor' - assigns the Main Contactor function to Relay Output A (default setting)

## 11.2 Installation with External Bypass Contactor

The EMX3 is installed with an external bypass contactor (AC1 rated). The bypass contactor is controlled by the EMX3 Run Output (terminals 23, 24).

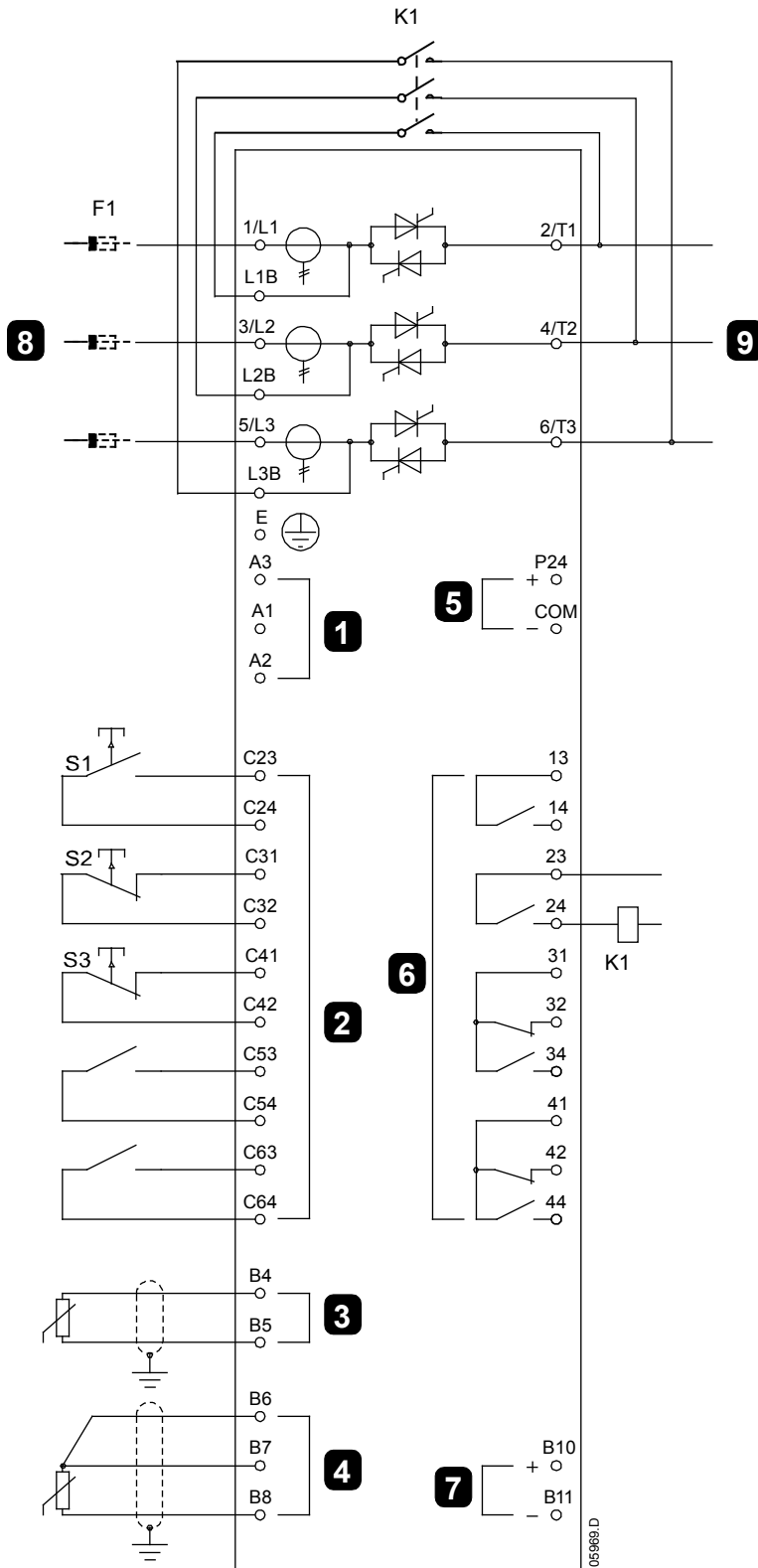

1	Control voltage (model dependent)
2	Remote control inputs
3	Motor thermistor input
4	RTD/PT100 input
5	24 VDC output
6	Relay outputs
7	Analog output
8	Three-phase supply
9	Motor terminals
K1	Bypass contactor (external)
F1	Semiconductor fuses (optional)
S1	Start contact
S2	Stop contact
S3	Reset contact
13, 14	Relay output A
23, 24	Run relay output
31, 32, 34	Relay output B
41, 42, 44	Relay output C

Parameter settings:

- No special settings required.



### 11.3 Emergency Run Operation

In normal operation the EMX3 is controlled via a remote two-wire signal (terminals C31, C32).

Emergency Run is controlled by a two-wire circuit connected to Input A (terminals C53, C54). Closing Input A causes the EMX3 to run the motor and ignore certain trip conditions.



**NOTE**

Although the Emergency Run satisfies the functionality requirements of Fire Mode, AuCom does not recommend its use in situations that require testing and/or compliance with specific standards as it is not certified.



**CAUTION**

Continued use of Emergency Run is not recommended. Emergency Run may compromise the starter life as all protections and trips are disabled.

Using the starter in 'Emergency Run' mode will void the product warranty.

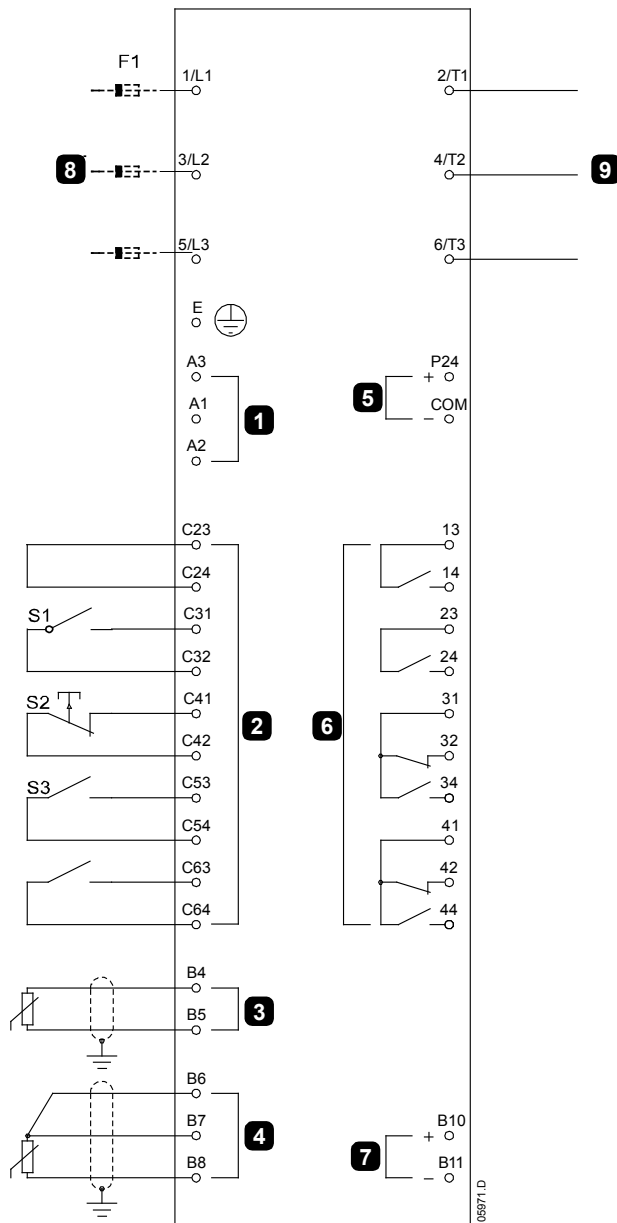

1	Control voltage (model dependent)
2	Remote control inputs
3	Motor thermistor input
4	RTD/PT100 input
5	24 VDC output
6	Relay outputs
7	Analog output
8	Three-phase supply
9	Motor terminals
S1	Start/stop contact
S2	Reset contact
S3	Emergency Run Contact
F1	Semiconductor fuses (optional)
13, 14	Relay output A
23, 24	Run relay output
31, 32, 34	Relay output B
41, 42, 44	Relay output C

Parameter settings:

- Parameter 6A *Input A Function*
  - Select 'Emergency Run' - assigns Input A for Emergency Run function.
- Parameter 15C *Emergency Run*
  - Select 'Enable' - Enables Emergency Run mode.

## 11.4 Auxiliary Trip Circuit

In normal operation the EMX3 is controlled via a remote two-wire signal (terminals C31, C32).

Input A (terminals C53, C54) is connected to an external trip circuit (such as a low pressure alarm switch for a pumping system). When the external circuit activates, the soft starter trips, which stops the motor.

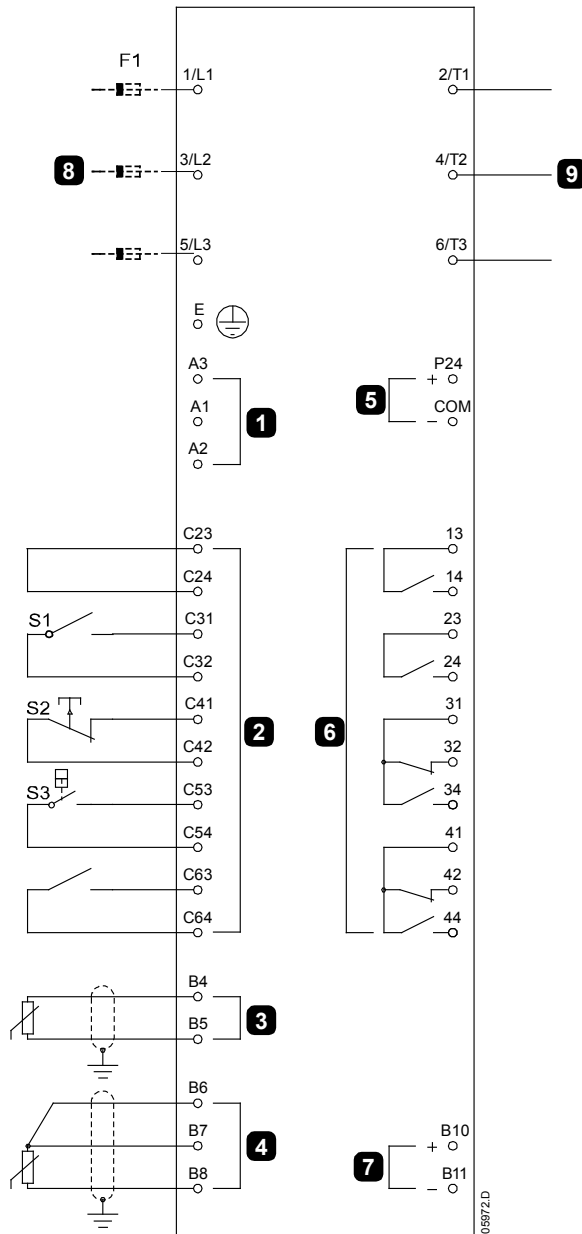

1	Control voltage (model dependent)
2	Remote control inputs
3	Motor thermistor input
4	RTD/PT100 input
5	24 VDC output
6	Relay outputs
7	Analog output
8	Three-phase supply
9	Motor terminals
S1	Start/stop contact
S2	Reset contact
S3	Auxiliary trip contact
F1	Semiconductor fuses (optional)
13, 14	Relay output A
23, 24	Run relay output
31, 32, 34	Relay output B
41, 42, 44	Relay output C

Parameter settings:

- Parameter 6A *Input A Function*
  - Select 'Input Trip (N/O)'. Assigns the Input A to Auxiliary Trip (N/O) function.
- Parameter 6B *Input A Name*
  - Select a name, eg Low Pressure. Assigns a name to Input A.
- Parameter 6C *Input A Trip*
  - Set as required. For example, 'Run Only' limits the input trip to when the soft starter is running only.
- Parameter 6D *Input A Trip Delay*
  - Set as required. Sets a delay between the input activating and the soft starter tripping.
- Parameter 6E *Input A Initial Delay*
  - Set at around 120 seconds. Limits operation of the input trip to 120 seconds after the start signal. This allows time for pressure to build up in the piping before the low pressure input becomes active.

### 11.5 DC Brake with External Zero Speed Sensor

For loads which may vary between braking cycles, there are benefits in using an external zero-speed sensor to interface with the EMX3 for brake shut-off. This control method ensures that the EMX3 braking will always shut off when the motor has reached a standstill, thus avoiding unnecessary motor heating.

The following schematic diagram shows how you can use a zero-speed sensor with the EMX3 to turn the brake function off at motor standstill. The zero-speed sensor (A2) is often referred to as an under-speed detector. Its internal contact is open at zero-speed and closed at any speed above zero-speed. Once the motor has reached a standstill, C53, C54 will open and the starter will be disabled. When the next start command is given (ie next application of K10), C53, C54 closes and the EMX3 is enabled.

The EMX3 must be operated in remote mode and parameter 6A *Input A Function* must be set to 'Starter Disable'.



**CAUTION**

Brake operation causes the motor to heat faster than the rate calculated by the motor thermal model. If you are using brake, install a motor thermistor or allow sufficient restart delay (parameter 4M).

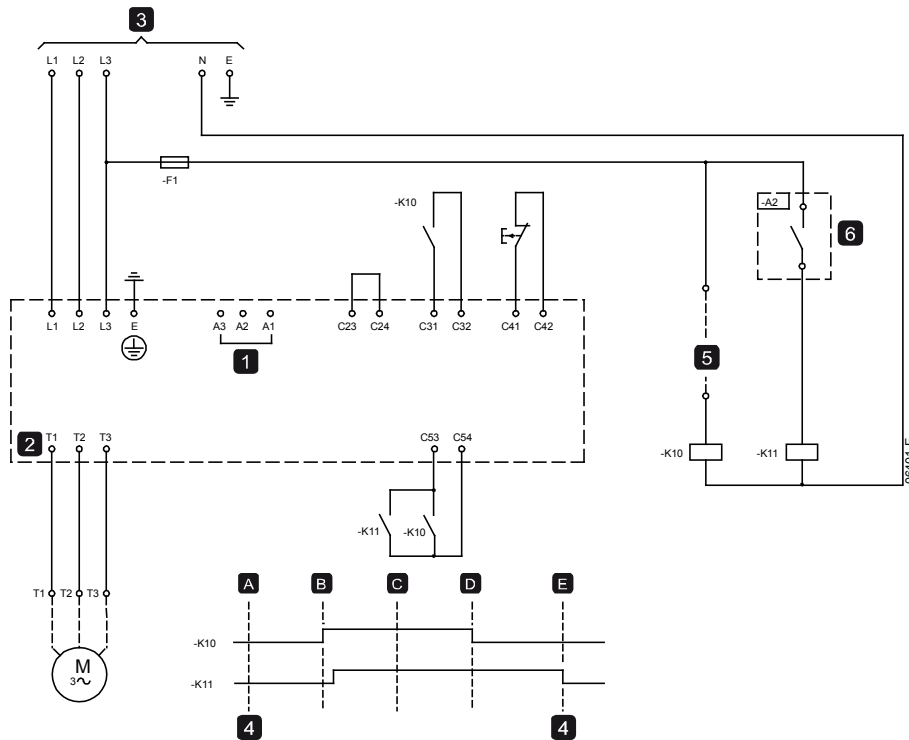

<b>1</b>	Control voltage	A	Off (Ready)
C23, C24	Start	B	Start
C31, C32	Stop	C	Run
C41, C42	Reset	D	Stop
C53, C54	Programmable input A (Starter Disable)	E	Zero speed
<b>2</b>	Motor terminals	<b>5</b>	Start signal
<b>3</b>	Three-phase supply	<b>6</b>	Zero speed sensor
<b>4</b>	Starter Disable (shown on starter display)		

For details on configuring DC Brake, refer to *Brake* on page 36.



**CAUTION**

When using DC brake, the mains supply must be connected to the soft starter (input terminals L1, L2, L3) in positive phase sequence and parameter 4G *Phase Sequence* must be set to Positive Only.



**CAUTION**

If the brake torque is set too high, the motor will stop before the end of the brake time and the motor will suffer unnecessary heating which could result in damage. Careful configuration is required to ensure safe operation of the starter and motor.

A high brake torque setting can result in peak currents up to motor DOL being drawn while the motor is stopping. Ensure protection fuses installed in the motor branch circuit are selected appropriately.

## 11.6 Soft Braking

For applications with high inertia and/or a variable load, the EMX3 can be configured for soft braking.

In this application the EMX3 is employed with forward run and braking contactors. When the EMX3 receives a start signal (pushbutton S1), it closes the forward run contactor (K1) and controls the motor according to the programmed primary motor settings.

When the EMX3 receives a stop signal (pushbutton S2), it opens the forward run contactor (K1) and closes the braking contactor (K2) after a delay of approximately 2-3 seconds (K1T). K12 is also closed to activate the secondary motor settings, which should be user programmed for the desired stopping performance characteristics.

When motor speed approaches zero, the zero speed sensor (A2) stops the soft starter and opens the braking contactor (K2).

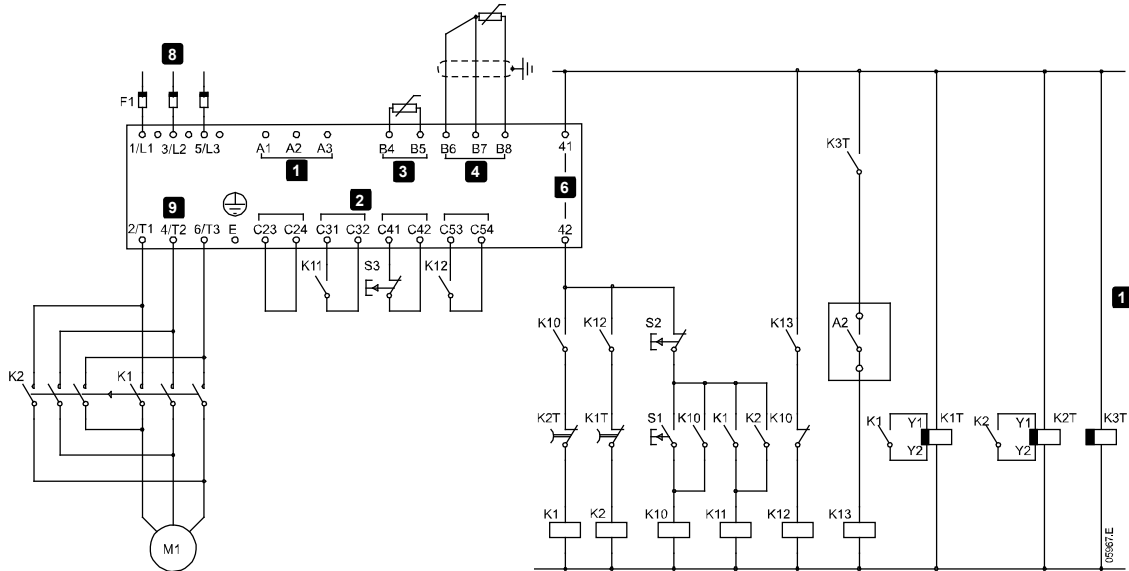

1	Control voltage (model dependent)	K12	Brake relay
2	Remote control inputs	K13	Zero speed sensor relay
3	Motor thermistor input	K1	Line contactor (Run)
4	RTD/PT100 input	K2	Line contactor (Brake)
5	Relay outputs	K1T	Run delay timer
6	Three-phase supply	K2T	Brake delay timer
7	Motor terminals	K3T	Zero speed sensor delay timer*
A2	Zero speed sensor	S1	Start contact
F1	Semiconductor fuses (optional)	S2	Stop contact
K10	Run relay	S3	Reset contact
K11	Start relay		

\* The K3T timer is only required if the zero speed sensor is the type that performs a self-test upon power-up and momentarily closes the output relay.

Parameter settings:

- Parameter *6A Input A Function* (terminals C53, C54)
  - Select 'Motor Set Select' - assigns Input A for Motor set selection.
  - Set starting performance characteristics using the primary motor set.
  - Set braking performance characteristics using the secondary motor settings.
- Parameter *7G Relay C Function*
  - Select 'Trip' - assigns Trip function to Relay Output C.



### NOTE

If the EMX3 trips on supply frequency (parameter 16F *Frequency*) when the braking contactor K2 opens, modify the frequency protection settings.

### 11.7 Two-Speed Motor

The EMX3 can be configured for control of dual speed Dahlander type motors, using a high speed contactor (K1), low speed contactor (K2) and a star contactor (K3).



**NOTE**

Pole Amplitude Modulated (PAM) motors alter the speed by effectively changing the stator frequency using external winding configuration. Soft starters are not suitable for use with this type of two-speed motor.

When the soft starter receives a high speed start signal, it closes the high speed contactor (K1) and star contactor (K3), then controls the motor according to the primary motor settings.

When the soft starter receives a low speed start signal, it closes the low speed contactor (K2). This closes Input A and the EMX3 controls the motor according to the secondary motor settings.

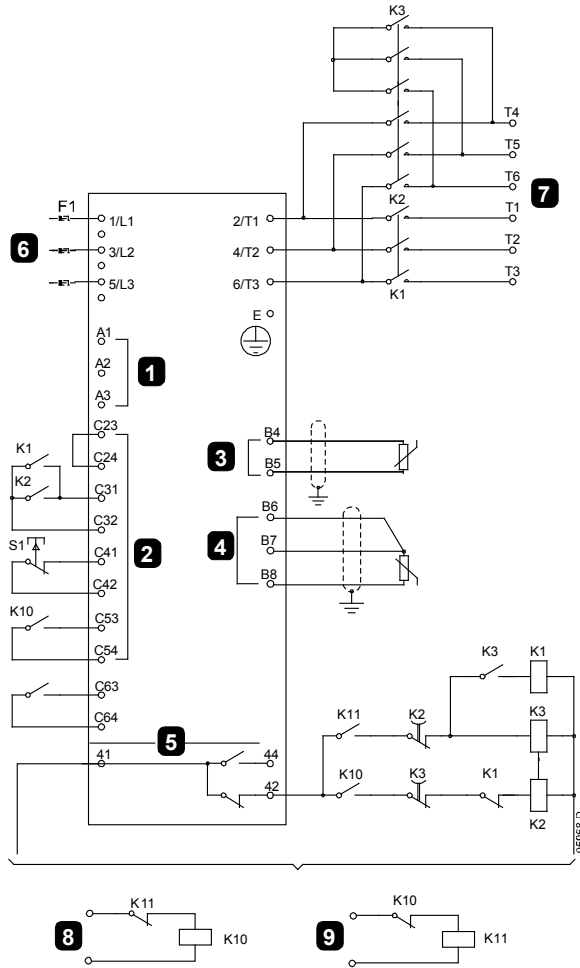

1	Control voltage
2	Remote control inputs
3	Motor thermistor input
4	RTD/PT100 input
5	Relay outputs
6	Three-phase supply
7	Motor terminals
8	Remote low speed start input
9	Remote high speed start input
F1	Semiconductor fuses (optional)
K10	Remote start relay (low speed)
K11	Remote start relay (high speed)
K1	Line contactor (high speed)
K2	Line contactor (low speed)
K3	Star contactor (high speed)
S1	Reset contact
41, 42, 44	Relay output C



**NOTE**

Contactors K2 and K3 must be mechanically interlocked.

Parameter settings:

- Parameter 6A *Input A Function* (terminals C53, C54)
  - Select 'Motor Set Select' - assigns Input A for Motor set selection.
  - Set high speed performance characteristics using the primary motor settings.
  - Set low speed performance characteristics using the secondary motor settings.
- Parameter 7G *Relay C Function*
  - Select 'Trip' - assigns Trip function to Relay Output C



**NOTE**

If the EMX3 trips on supply frequency (parameter 16F *Frequency*) when the high-speed start signal (9) is removed, modify the frequency protection settings.

## 11.8 Slip-Ring Motor

The EMX3 can be used to control a slip-ring motor, using rotor resistance.

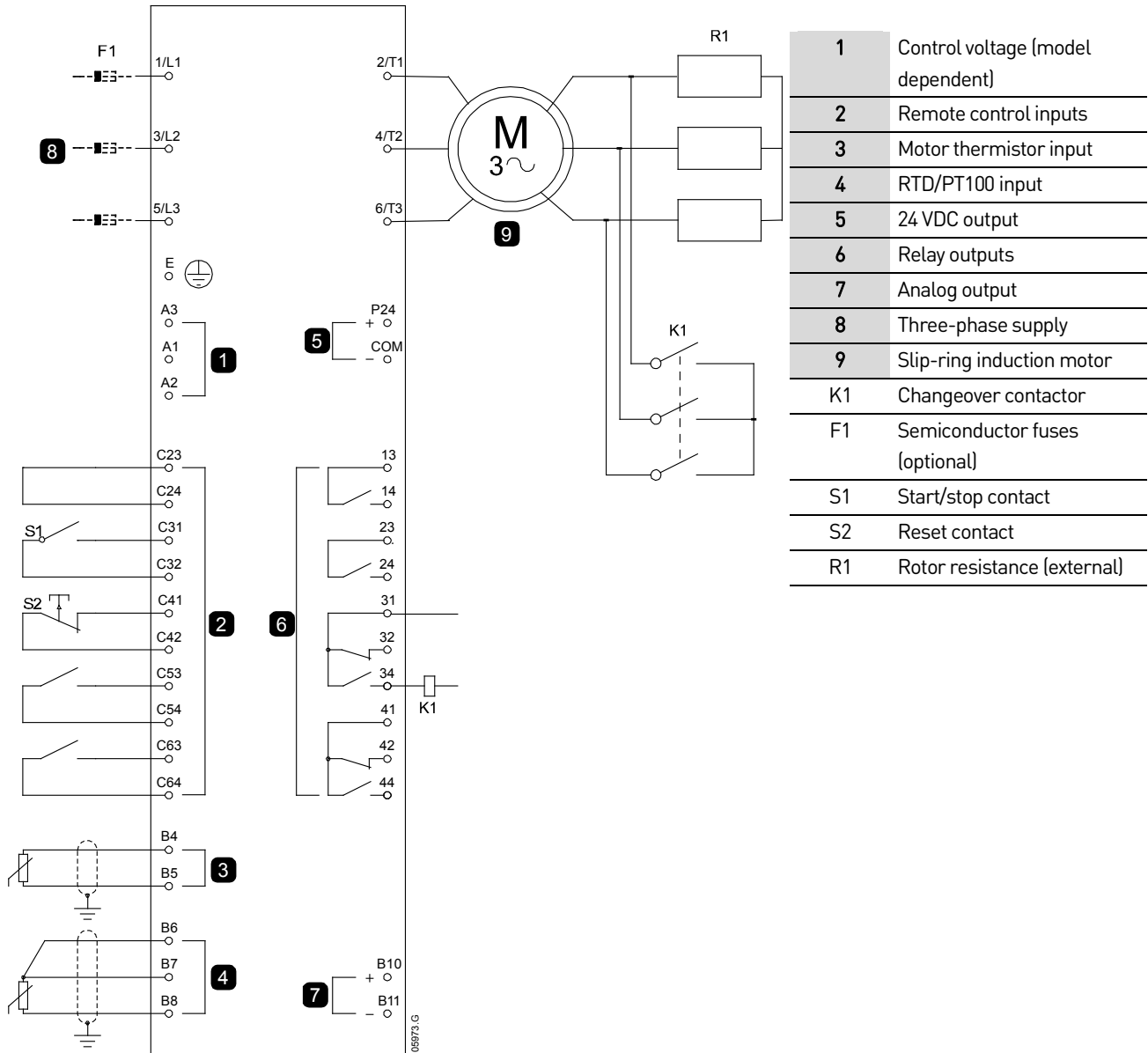

## Commissioning

1. Configure the EMX3 as follows:

Parameter settings:

- Parameter *7D Relay B Function*
    - Select 'Changeover contactor'
  - Parameter *7E Relay B On Delay*
    - Set this to the maximum time (5m:00s).
  - Parameter *12A Motor Data-1 Ramp*
    - Select 'Dual Ramp' (for slip-ring induction motor control)
  - Parameter *12C Changeover Time*
    - Default setting is 150 milliseconds. Set this to a value just greater than the changeover contactor (K1) pole closing time.
  - Parameter *12D Slip Ring Retard*
    - Default setting is 50%. Set this parameter to a value which is high enough to cause the motor to instantly accelerate once the rotor resistance (R1) has been bridged out and low enough to avoid a motor current pulse.
2. Start the motor under normal load conditions and record the time it takes to reach a constant speed with external rotor resistance (R1) in the circuit. Stop the motor soon after a constant speed has been reached. Change parameter 7E to the recorded time value.
  3. Start the motor under normal load conditions and monitor the motor speed behaviour and motor current when the changeover contactor (K1) switches in to short-out the rotor resistance (R1).  
If the motor does not accelerate immediately after changeover, increase the setting of parameter 12D.  
If there is a pulse in motor current immediately after changeover, reduce the setting of parameter 12D.

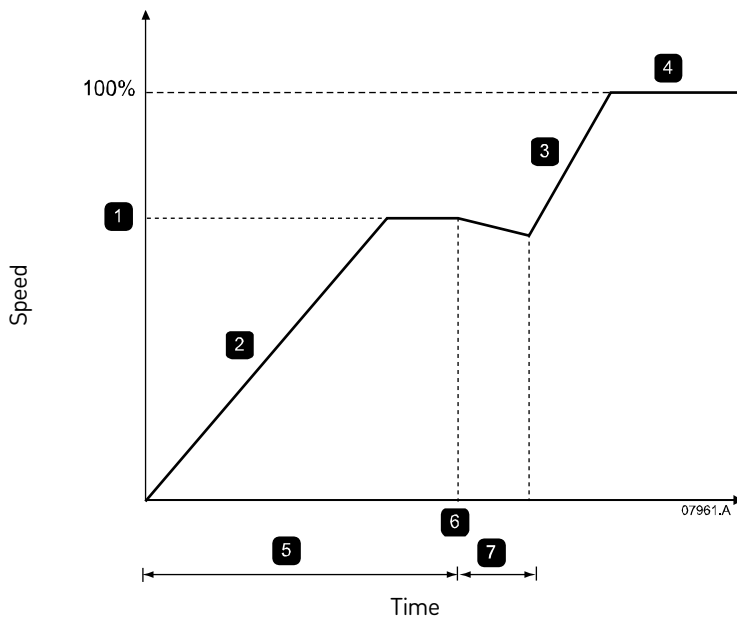

1	R1 Constant Speed
2	First ramp
3	Second ramp
4	Run mode ( $I < 120\%$ FLC)

5	Parameter <i>7E Relay B On Delay</i>
6	K1 closes
7	Parameter <i>12C Changeover Time</i>



### NOTE

For this installation to function correctly, only use the primary motor settings with constant current start method (parameter *2A Start Mode*).

## 12. Troubleshooting

### 12.1 Protection Responses

When a protection condition is detected, the EMX3 will write this to the event log and may also trip or issue a warning. The soft starter's response depends on the Protection Action setting (parameter group 16).

Some protection responses cannot be adjusted by the user. These trips are usually caused by external events (such as phase loss) or by a fault within the soft starter. These trips do not have associated parameters and cannot be set to Warn or Log.

If the EMX3 trips you will need to identify and clear the condition that triggered the trip, then reset the soft starter before restarting. To reset the starter, press the **RESET** button on the keypad or activate the Reset remote input.



If the EMX3 has issued a warning, the soft starter will reset itself once the cause of the warning has been resolved.

### 12.2 Trip Messages

This table lists soft starter's protection mechanisms and the probable cause of the trip. Some of these can be adjusted using parameter group 4 Protection Settings and parameter group 16 Protection Action, other settings are built-in system protections and cannot be set or adjusted.

Display	Possible cause/Suggested solution
<b>2 Phase - Damaged SCR</b>	<p>This message is displayed if the soft starter tripped on "Lx-Tx shorted" during the pre-start checks and PowerThrough is enabled. It indicates that the starter now operates in PowerThrough mode (2-phase control only).</p> <p>Check for either a shorted SCR or a short within the bypass contactor.</p> <p>Related parameters: 15D</p>
<b>Battery/clock</b>	<p>A verification error has occurred on the real time clock, or the backup battery voltage is low. If the battery is low and the power is off, date/time settings will be lost. The EMX3 will continue to soft start and soft stop correctly. Reprogram the date and time.</p> <p>The battery is not removable. In order to replace the battery, the main control PCB must be replaced.</p> <p>Related parameters: 16M</p>
<b>Controller</b>	<p>This is a name selected for a programmable input. Refer to Input A trip.</p>
<b>Current imbalance</b>	<p>Current imbalance can be caused by problems with the motor, the environment or the installation, such as:</p> <ul style="list-style-type: none"> <li>• An imbalance in the incoming mains voltage</li> <li>• A problem with the motor windings</li> <li>• A light load on the motor</li> <li>• A phase loss on input terminals L1, L2 or L3 during Run mode</li> <li>• An SCR that has failed open circuit. A failed SCR can only be definitely diagnosed by replacing the SCR and checking the starter's performance.</li> </ul> <p>Related parameters: 4H, 4I, 16E</p>
<b>Current Read Err Lx</b>	<p>Where 'X' is 1, 2 or 3.</p> <p>Internal fault (PCB fault). The output from the CT circuit is not close enough to zero when the SCRs are turned off. Contact your local supplier for advice.</p> <p>This trip is not adjustable.</p> <p>Related parameters: None</p>
<b>Excess start time</b>	<p>Excess start time trip can occur in the following conditions:</p> <ul style="list-style-type: none"> <li>• parameter 1A <i>Motor Full Load Current</i> is not appropriate for the motor</li> <li>• parameter 2D <i>Current Limit</i> has been set too low</li> <li>• parameter 2B <i>Start Ramp Time</i> has been set greater than the setting for 4A <i>Excess Start Time</i> setting</li> <li>• parameter 2B <i>Start Ramp Time</i> is set too short for a high inertia load when using Adaptive Control</li> </ul> <p>Related parameters: 1A, 9B, 2D, 2B, 4A, 10D, 10B, 4B, 16B</p>
<b>Firing Fail Px</b>	<p>Where 'X' is phase 1, 2 or 3.</p> <p>The SCR did not fire as expected. The SCR may be faulty or there may be an internal wiring fault.</p> <p>This trip is not adjustable.</p> <p>Related parameters: None</p>



Display	Possible cause/Suggest
<b>FLC too high</b>	<p>The EMX3 can support higher motor full load current values when connected to the motor using inside delta configuration rather than in-line connection. If the soft starter is connected in-line but the programmed setting for parameter 1A <i>Motor Full Load Current</i> is above the in-line maximum, the soft starter will trip at start (see <i>Minimum and Maximum Current Settings</i> on page 82).</p> <p>If the soft starter is connected to the motor using inside delta configuration, the soft starter may not be correctly detecting the connection. Contact your local supplier for advice.</p> <p>Related parameters: 1A, 9B</p>
<b>Frequency</b>	<p>The mains frequency has gone beyond the specified range.</p> <p>Check for other equipment in the area that could be affecting the mains supply, particularly variable speed drives and switch mode power supplies (SMPS).</p> <p>If the EMX3 is connected to a generator set supply, the generator may be too small or could have a speed regulation problem.</p> <p>Related parameters: 4J, 4K, 4L, 16F</p>
<b>Ground Fault</b>	<p>Test the insulation of the output cables and the motor. Identify and resolve the cause of any ground fault.</p> <p> <b>NOTE</b> Ground fault protection is only available if the RTD/PT100 and ground fault protection card is fitted.</p> <p>Related parameters: 4O, 4P, 16N</p>
<b>Heatsink overtemperature</b>	<p>Check if cooling fans are operating. If mounted in an enclosure, check if ventilation is adequate. Fans operate during Start, Run and for 10 minutes after the starter exits the Stop state.</p> <p> <b>NOTE</b> Models EMX3-0023B to EMX3-0053B and EMX3-0170B do not have a cooling fan. Models with fans will operate the cooling fans from a Start until 10 minutes after a Stop.</p> <p>Related parameters: 16L</p>
<b>High Level</b>	This is a name selected for a programmable input. Refer to Input A trip.
<b>High Pressure</b>	This is a name selected for a programmable input. Refer to Input A trip.
<b>Input A trip</b>	<p>One of the soft starter's inputs is set to a trip function and has activated. Check the status of the inputs to identify which input has activated, then resolve the trigger condition.</p> <p>Related parameters: 6C, 6D, 6E, 6A, 6B, 16G</p>
<b>Instantaneous overcurrent</b>	<p>There has been a sharp rise in motor current, probably caused by a locked rotor condition (shear pin) while running. This may indicate a jammed load.</p> <p>Related parameters: 4E, 4F, 16D</p>
<b>Internal fault X</b>	<p>The EMX3 has tripped on an internal fault. Contact your local supplier with the fault code (X).</p> <p>Related parameters: None</p>
<b>L1 phase loss L2 phase loss L3 phase loss</b>	<p>During pre-start checks the starter has detected a phase loss as indicated.</p> <p>In run state, the starter has detected that the current on the affected phase has dropped below 2% of the programmed motor FLC for more than 1 second, indicating that either the incoming phase or connection to the motor has been lost.</p> <p>Check the supply and the input and output connections at the starter and at the motor end.</p> <p>Related parameters: None</p>
<b>L1-T1 shorted L2-T2 shorted L3-T3 shorted</b>	<p>During pre-start checks the starter has detected a shorted SCR or a short within the bypass contactor as indicated. If the starter is connected in-line with the motor, consider using PowerThrough to allow operation until the starter can be repaired.</p> <p> <b>NOTE</b> PowerThrough is only available with in-line installations. If the starter is installed inside delta, PowerThrough will not operate.</p> <p>The starter will trip on Lx-Tx Shorted on the first start attempt after control power is applied. PowerThrough will not operate if control power is cycled between starts.</p> <p>Related parameters: 15D</p>

Display	Possible cause/Suggest
<b>Low Control Volts</b>	<p>The EMX3 has detected a drop in the internal control voltage.</p> <ul style="list-style-type: none"> <li>Check the external control supply (A1, A2, A3) and reset the starter.</li> </ul> <p>If the external control supply is stable:</p> <ul style="list-style-type: none"> <li>the 24 V supply on the main control PCB may be faulty; or</li> <li>the bypass driver PCB may be faulty (internally bypassed models only). Contact your local supplier for advice.</li> </ul> <p>This protection is not active in Ready state.</p> <p>Related parameters: 16X</p>
<b>Low Level</b>	This is a name selected for a programmable input. Refer to Input A trip.
<b>Low Pressure</b>	This is a name selected for a programmable input. Refer to Input A trip.
<b>Motor Connection Tx</b>	<p>Where 'X' is 1, 2 or 3.</p> <p>The motor is not connected correctly to the soft starter.</p> <ul style="list-style-type: none"> <li>Check individual motor connections to the soft starter for power circuit continuity.</li> <li>Check connections at the motor terminal box.</li> </ul> <p>This trip is not adjustable.</p> <p>Related parameters: None</p>
<b>Motor overload Motor 2 overload</b>	<p>The motor has reached its maximum thermal capacity. Overload can be caused by:</p> <ul style="list-style-type: none"> <li>The soft starter protection settings not matching the motor thermal capacity</li> <li>Excessive starts per hour or start duration</li> <li>Excessive current</li> <li>Damage to the motor windings</li> </ul> <p>Resolve the cause of the overload and allow the motor to cool.</p> <p>Related parameters: 1A, 1B, 9B, 9C, 2A, 2D, 10A, 10D, 16A</p>
<b>Motor thermistor</b>	<p>The motor thermistor input has been enabled and:</p> <ul style="list-style-type: none"> <li>The resistance at the thermistor input has exceeded 3.6 kΩ for more than one second.</li> <li>The motor winding has overheated. Identify the cause of the overheating and allow the motor to cool before restarting.</li> <li>The motor thermistor input has been opened.</li> </ul> <p> <b>NOTE</b> If a valid motor thermistor is no longer used, a 1.2 kΩ resistor must be fitted across terminals B4, B5.</p> <p>Related parameters: 16I</p>
<b>Network communication (between device and network)</b>	<p>There is a network communication problem, or the network master may have sent a trip command to the starter. Check the network for causes of communication inactivity.</p> <p>Related parameters: 16K</p>
<b>No Flow</b>	This is a name selected for a programmable input. Refer to Input A trip.
<b>Parameter out of range</b>	<ul style="list-style-type: none"> <li>A parameter value is outside the valid range.</li> </ul> <p>The starter will load the default value for all affected parameters. Press <b>RESET</b> to go to the first invalid parameter and adjust the setting.</p> <p>Related parameters: None</p>
<b>Phase sequence</b>	<p>The phase sequence on the soft starter's input terminals (L1, L2, L3) is not valid.</p> <p>Check the phase sequence on L1, L2, L3 and ensure the setting in parameter 4G is suitable for the installation.</p> <p>Related parameters: 4G</p>
<b>PLC</b>	This is a name selected for a programmable input. Refer to Input A trip.
<b>Power loss</b>	<p>The starter is not receiving mains supply on one or more phases when a Start Command is given.</p> <p>Check that the main contactor closes when a start command is given, and remains closed until the end of a soft stop. Check the fuses. If testing the soft starter with a small motor, it must draw at least 2% of its minimum FLC setting on each phase.</p> <p>Related parameters: None</p>
<b>Pump Fault</b>	This is a name selected for a programmable input. Refer to Input A trip.

Display	Possible cause/Suggest
<b>RTD/PT100 A~ RTD/PT100 G</b>	<p>The RTD/PT100 set temperature has been exceeded and tripped the soft starter. Identify and resolve the condition which caused the appropriate input to activate.</p> <p> <b>NOTE</b> PT100 B to PT100 G are applicable only if a RTD/PT100 and Ground Fault card is fitted.</p> <p>Related parameters: 11A~11G, 16O~16U</p>
<b>RTD circuit fail</b>	<p>Indicates that the indicated RTD/PT100 has short circuited. Check and resolve this condition.</p> <p>Related parameters: None</p>
<b>Starter communication (between device and soft starter)</b>	<ul style="list-style-type: none"> <li>There is a problem with the connection between the soft starter and the optional communications module. Remove and reinstall the module. If the problem persists, contact your local distributor.</li> <li>There is an internal communications error within the soft starter. Contact your local distributor.</li> </ul> <p>Related parameters: 16J</p>
<b>Starter Disable</b>	<p>This is a name selected for a programmable input. Refer to Input A trip.</p>
<b>Thermistor circuit</b>	<p>Check that a PT100 (RTD) is not connected to B4, B5.</p> <p>The thermistor input has been enabled and:</p> <ul style="list-style-type: none"> <li>The resistance at the input has fallen below 20 Ω (the cold resistance of most thermistors will be over this value) or</li> <li>A short circuit has occurred. Check and resolve this condition.</li> </ul> <p>Related parameters: None</p>
<b>Time-overcurrent</b>	<p>The EMX3 is internally bypassed and has drawn high current during running. (The 10A protection curve trip has been reached or the motor current has risen to 600% of the motor FLC setting.)</p> <p>Related parameters: None</p>
<b>Undercurrent</b>	<p>The motor has experienced a sharp drop in current, caused by loss of load. Causes can include broken components (shafts, belts or couplings), or a pump running dry.</p> <p>Related parameters: 4C, 4D, 16C</p>
<b>Unsupported option (function not available in inside delta)</b>	<p>The selected function is not available (eg jog is not supported in inside delta configuration).</p> <p>Related parameters: None</p>
<b>Vibration</b>	<p>This is a name selected for a programmable input. Refer to Input A trip.</p>
<b>VZC Fail Px</b>	<p>Where 'X' is 1, 2 or 3.</p> <p>Internal fault (PCB fault). Contact your local supplier for advice.</p> <p>This trip is not adjustable.</p> <p>Related parameters: None</p>

## 12.3 General Faults

This table describes situations where the soft starter does not operate as expected but does not trip or give a warning.

Symptom	Probable Cause
Starter "Not Ready"	<ul style="list-style-type: none"> <li>Check Input A (C53, C54). The starter may be disabled via a programmable input. If parameter 6A or 6F is set to Starter Disable and there is an open circuit on the corresponding input, the EMX3 will not start.</li> </ul>
The soft starter does not respond to the <b>START</b> or <b>RESET</b> button on the keypad.	<ul style="list-style-type: none"> <li>The soft starter may be in Remote control mode. When the soft starter is in Remote control mode, the Local LED on the starter is off. Press the <b>LCL/RMT</b> button once to change to Local control.</li> </ul>
The soft starter does not respond to commands from the control inputs.	<ul style="list-style-type: none"> <li>The soft starter may be in Local control mode. When the soft starter is in Local control mode, the Local LED on the starter is on. Press the <b>LCL/RMT</b> button once to change to Remote control.</li> <li>The control wiring may be incorrect. Check that the remote start, stop and reset inputs are configured correctly (refer to <i>Control Wiring</i> on page 10 for details).</li> <li>The signals to the remote inputs may be incorrect. Test the signalling by activating each input signal in turn. The appropriate remote control input LED should activate on the starter.</li> </ul>
The soft starter does not respond to a start command from either the local or remote controls.	<ul style="list-style-type: none"> <li>The soft starter may be waiting for the restart delay to elapse. The length of the restart delay is controlled by parameter 4M <i>Restart Delay</i>.</li> <li>The motor may be too hot to permit a start. If parameter 4N <i>Motor Temperature Check</i> is set to Check, the soft starter will only permit a start when it calculates that the motor has sufficient thermal capacity to complete the start successfully. Wait for the motor to cool before attempting another start.</li> <li>The starter may be disabled via a programmable input. If parameter 6A or 6F is set to Starter Disable and there is an open circuit on the corresponding input, the EMX3 will not start. If there is no further need to disable the starter, close the circuit on the input.</li> </ul>
<p> <b>NOTE</b> Parameter 6Q <i>Local/Remote</i> controls when the <b>LCL/RMT</b> button is enabled.</p>	
A reset does not occur after an Auto-Reset, when using a remote two-wire control.	<ul style="list-style-type: none"> <li>The remote 2-wire start signal must be removed and reapplied for a re-start.</li> </ul>
Remote start/stop command is overriding Auto Start/Stop settings when using remote two-wire control.	<ul style="list-style-type: none"> <li>Auto Start/Stop should only be used in remote mode with three-wire or four-wire control.</li> </ul>
Non-resettable Thermistor Cct trip, when there is a link between the thermistor input B4, B5 or when the motor thermistor connected between B4, B5 is permanently removed.	<ul style="list-style-type: none"> <li>The thermistor input is enabled once a link is fitted and short circuit protection has activated. <ul style="list-style-type: none"> <li>Remove the link then load the default parameter set. This will disable the thermistor input and clear the trip.</li> <li>Place a 1k2Ω resistor across the thermistor input.</li> <li>Turn thermistor protection to 'Log only' (parameter 16I).</li> </ul> </li> </ul>
Remote start/stop command is overriding Auto Start/Stop settings when using remote two-wire control.	<ul style="list-style-type: none"> <li>Auto Start/Stop should only be used in remote mode with three-wire or four-wire control.</li> </ul>
The soft starter does not control the motor correctly during starting.	<ul style="list-style-type: none"> <li>Start performance may be unstable when using a low <i>Motor Full Load Current</i> setting (parameter 1A).</li> <li>Power factor correction (PFC) capacitors must be installed on the supply side of the soft starter and must be disconnected during starting and stopping. To control a dedicated PFC capacitor contactor, connect the contactor to run relay terminals.</li> </ul>

Symptom	Probable Cause
Motor does not reach full speed.	<ul style="list-style-type: none"> <li>If the start current is too low, the motor will not produce enough torque to accelerate to full speed. The soft starter may trip on excess start time.</li> </ul> <p><b>NOTE</b></p> <p> Make sure the motor starting parameters are appropriate for the application and that you are using the intended motor starting profile. If a programmable input is set to Motor Set Select, check that the corresponding input is in the expected state.</p> <p>The load may be jammed. Check the load for severe overloading or a locked rotor situation.</p>
Erratic motor operation.	<ul style="list-style-type: none"> <li>The SCRs in the EMX3 require at least 5 A of current to latch. If you are testing the soft starter on a motor with full load current less than 5 A, the SCRs may not latch correctly.</li> </ul>
Erratic and noisy motor operation.	<ul style="list-style-type: none"> <li>If the soft starter is connected to the motor using inside delta configuration, the soft starter may not be correctly detecting the connection. Contact your local supplier for advice.</li> </ul>
Soft stop ends too quickly.	<ul style="list-style-type: none"> <li>The soft stop settings may not be appropriate for the motor and load. Review the soft stop settings.</li> <li>If the motor is very lightly loaded, soft stop will have limited effect.</li> </ul>
Adaptive Control, brake, jog and PowerThrough functions not working.	<ul style="list-style-type: none"> <li>These features are only available with in-line installation. If the EMX3 is installed inside delta, these features will not operate.</li> </ul>
After selecting Adaptive Control the motor used an ordinary start and/or the second start was different to the first.	<ul style="list-style-type: none"> <li>The first Adaptive Control start is actually 'Constant Current' so that the starter can learn from the motor characteristics. Subsequent starts use Adaptive Control.</li> </ul>
PowerThrough does not operate when selected.	<ul style="list-style-type: none"> <li>The starter will trip on Lx-Tx Shorted on the first start attempt after control power is applied. PowerThrough will not operate if control power is cycled between starts.</li> </ul>
Starter "awaiting data"	<ul style="list-style-type: none"> <li>The keypad is not receiving data from the control PCB. Check the cable connection and the fitting of the display on the starter.</li> </ul>
Corrupted text shown on keypad display.	<ul style="list-style-type: none"> <li>The keypad may not be screwed down, resulting in an intermittent connection. Screw down the keypad or hold squarely in place.</li> </ul>
Display is distorted	<ul style="list-style-type: none"> <li>Check that the keypad has not been screwed down too tightly. Loosen screws slightly.</li> </ul>
Parameter settings cannot be stored.	<ul style="list-style-type: none"> <li>Make sure you are saving the new value by pressing the <b>STORE</b> button after adjusting a parameter setting. If you press <b>EXIT</b>, the change will not be saved.</li> <li>Check that the adjustment lock (parameter 15B) is set to <i>Read &amp; Write</i>. If the adjustment lock is set to <i>Read Only</i>, settings can be viewed but not changed. You need to know the security access code to change the adjustment lock setting.</li> <li>The EEPROM may be faulty on the keypad. A faulty EEPROM will also trip the soft starter, and the keypad will display the message Parameter out of range. Contact your local supplier for advice.</li> </ul>
ATTENTION! Remove Mains Volts	<ul style="list-style-type: none"> <li>The soft starter will not activate Run Simulation with three-phase power connected. This prevents unintentional direct on-line (DOL) start.</li> </ul>

## 13. Appendix

### 13.1 Model code

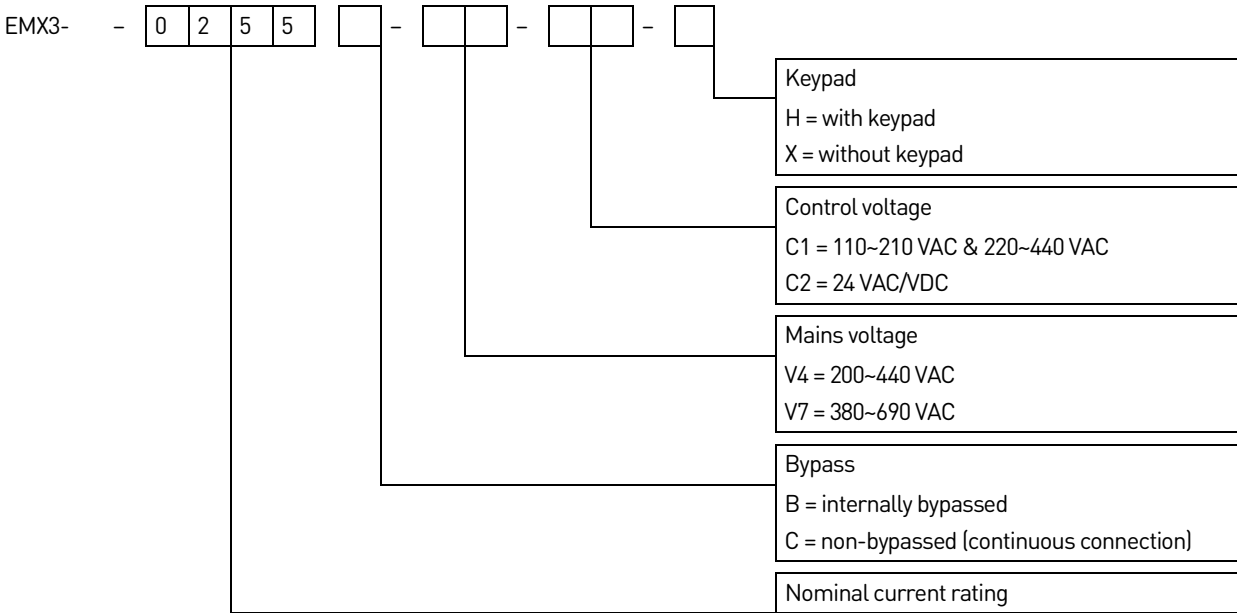

### 13.2 IEC ratings

#### Current Ratings for Bypass Operation

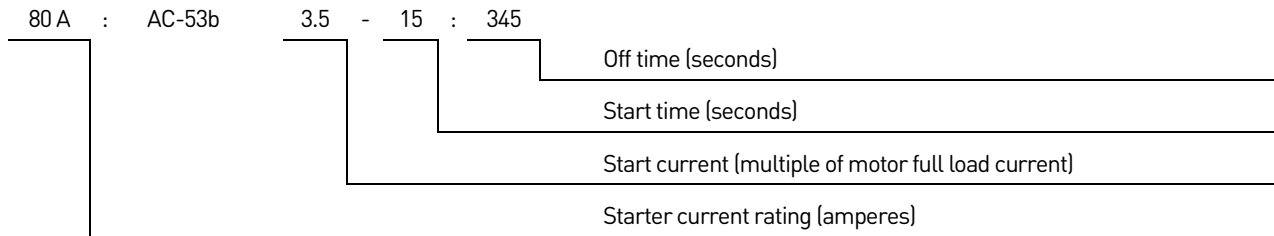

**NOTE**

Models EMX3-0255C, EMX3-0360C, EMX3-0380C, EMX3-0430C, EMX3-0620C, EMX3-0650C, EMX3-0790C, EMX3-0930C, EMX3-1200C, EMX3-1410C, EMX3-1600C must be externally bypassed.

In-line connection

	AC53b 3.0-10:350 40 °C <1000 metres	AC53b 3.5-15:345 40 °C <1000 metres	AC53b 4.0-20:340 40 °C <1000 metres	AC53b 4.5-30:330 40 °C <1000 metres
EMX3-0023B	23 A	20 A	17 A	15 A
EMX3-0043B	43 A	37 A	31 A	26 A
EMX3-0050B	50 A	44 A	37 A	30 A
EMX3-0053B	53 A	53 A	46 A	37 A

	AC53b 3.0-10:590 40 °C <1000 metres	AC53b 3.5-15:585 40 °C <1000 metres	AC53b 4.0-20:580 40 °C <1000 metres	AC53b 4.5-30:570 40 °C <1000 metres
EMX3-0076B	76 A	64 A	55 A	47 A
EMX3-0097B	97 A	82 A	69 A	58 A
EMX3-0100B	100 A	88 A	74 A	61 A
EMX3-0105B	105 A	105 A	95 A	78 A
EMX3-0145B	145 A	123 A	106 A	90 A
EMX3-0170B	170 A	145 A	121 A	97 A
EMX3-0200B	200 A	189 A	160 A	134 A
EMX3-0220B	220 A	210 A	178 A	158 A

EMX3-0255B	255 A		201 A	176 A
EMX3-0255C	255 A	231 A	201 A	176 A
EMX3-0350B	350 A	329 A	284 A	244 A
EMX3-0360C	360 A	360 A	310 A	263 A
EMX3-0380C	380 A	380 A	359 A	299 A
EMX3-0425B	425 A	411 A	355 A	305 A
EMX3-0430C	430 A	430 A	368 A	309 A
EMX3-0500B	500 A	445 A	383 A	326 A
EMX3-0580B	580 A	492 A	425 A	364 A
EMX3-0620C	620 A	620 A	540 A	438 A
EMX3-0650C	650 A	650 A	561 A	455 A
EMX3-0700B	700 A	592 A	512 A	438 A
EMX3-0790C	790 A	790 A	714 A	579 A
EMX3-0820B	820 A	705 A	606 A	516 A
EMX3-0920B	920 A	804 A	684 A	571 A
EMX3-0930C	930 A	930 A	829 A	661 A
EMX3-1000B	1000 A	936 A	796 A	664 A
EMX3-1200C	1200 A	1200 A	1200 A	1071 A
EMX3-1410C	1410 A	1410 A	1319 A	1114 A
EMX3-1600C	1600 A	1600 A	1600 A	1353 A

Inside delta connection

	AC53b 3.0-10:350 40 °C <1000 metres	AC53b 3.5-15:345 40 °C <1000 metres	AC53b 4.0-20:340 40 °C <1000 metres	AC53b 4.5-30:330 40 °C <1000 metres
EMX3-0023B	34 A	30 A	26 A	22 A
EMX3-0043B	64 A	59 A	51 A	44 A
EMX3-0050B	75 A	66 A	55 A	45 A
EMX3-0053B	80 A	80 A	69 A	55 A

	AC53b 3.0-10:590 40 °C <1000 metres	AC53b 3.5-15:585 40 °C <1000 metres	AC53b 4.0-20:580 40 °C <1000 metres	AC53b 4.5-30:570 40 °C <1000 metres
EMX3-0076B	114 A	96 A	83 A	70 A
EMX3-0097B	145 A	123 A	104 A	87 A
EMX3-0100B	150 A	132 A	112 A	92 A
EMX3-0105B	157 A	158 A	143 A	117 A
EMX3-0145B	218 A	184 A	159 A	136 A
EMX3-0170B	255 A	217 A	181 A	146 A
EMX3-0200B	300 A	283 A	241 A	213 A
EMX3-0220B	330 A	315 A	268 A	238 A
EMX3-0255B	382 A	346 A	302 A	264 A
EMX3-0255C	382 A	346 A	302 A	264 A
EMX3-0350B	525 A	494 A	427 A	366 A
EMX3-0360C	540 A	540 A	465 A	395 A
EMX3-0380C	570 A	570 A	539 A	449 A
EMX3-0425B	638 A	617 A	533 A	458 A
EMX3-0430C	645 A	645 A	552 A	464 A
EMX3-0500B	750 A	668 A	575 A	490 A
EMX3-0580B	870 A	738 A	637 A	546 A
EMX3-0620C	930 A	930 A	810 A	651 A
EMX3-0650C	975 A	975 A	842 A	683 A
EMX3-0700B	1050 A	889 A	768 A	658 A

EMX3-0790C	1185 A		1075 A	868 A
EMX3-0820B	1230 A	1058 A	910 A	774 A
EMX3-0920B	1380 A	1206 A	1026 A	857 A
EMX3-0930C	1395 A	1395 A	1244 A	992 A
EMX3-1000B	1500 A	1404 A	1194 A	997 A
EMX3-1200C	1800 A	1800 A	1800 A	1606 A
EMX3-1410C	2115 A	2115 A	1979 A	1671 A
EMX3-1600C	2400 A	2400 A	2400 A	2030 A

### Current Ratings for Continuous Operation (Not bypassed)

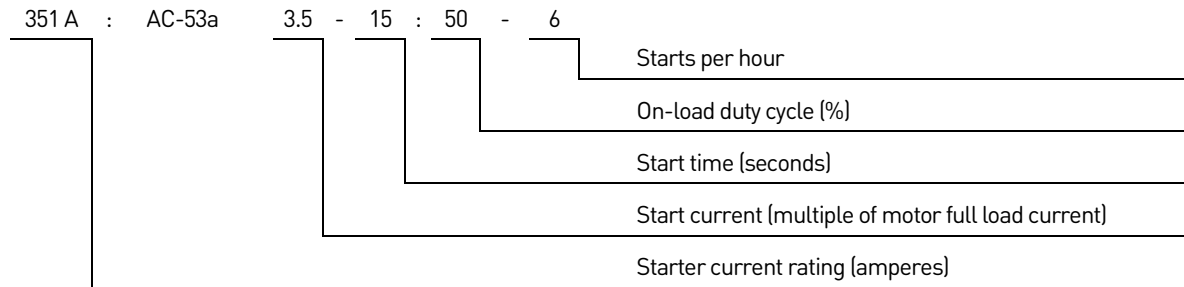

In-line connection

	AC53a 3-10:50-6 40 °C <1000 metres	AC53a 3.5-15:50-6 40 °C <1000 metres	AC53a 4-20:50-6 40 °C <1000 metres	AC53a 4.5-30:50-6 40 °C <1000 metres
EMX3-0255C	255 A	222 A	195 A	171 A
EMX3-0360C	360 A	351 A	303 A	259 A
EMX3-0380C	380 A	380 A	348 A	292 A
EMX3-0430C	430 A	413 A	355 A	301 A
EMX3-0620C	620 A	614 A	515 A	419 A
EMX3-0650C	650 A	629 A	532 A	437 A
EMX3-0790C	790 A	790 A	694 A	567 A
EMX3-0930C	930 A	930 A	800 A	644 A
EMX3-1200C	1200 A	1200 A	1135 A	983 A
EMX3-1410C	1410 A	1355 A	1187 A	1023 A
EMX3-1600C	1600 A	1600 A	1433 A	1227 A

Inside delta connection

	AC53a 3-10:50-6 40 °C <1000 metres	AC53a 3.5-15:50-6 40 °C <1000 metres	AC53a 4-20:50-6 40 °C <1000 metres	AC53a 4.5-30:50-6 40 °C <1000 metres
EMX3-0255C	382 A	334 A	293 A	257 A
EMX3-0360C	540 A	527 A	455 A	388 A
EMX3-0380C	570 A	570 A	522 A	437 A
EMX3-0430C	645 A	620 A	533 A	451 A
EMX3-0620C	930 A	920 A	773 A	628 A
EMX3-0650C	975 A	943 A	798 A	656 A
EMX3-0790C	1185 A	1185 A	1041 A	850 A
EMX3-0930C	1395 A	1395 A	1200 A	966 A
EMX3-1200C	1800 A	1800 A	1702 A	1474 A
EMX3-1410C	2115 A	2033 A	1780 A	1535 A
EMX3-1600C	2400 A	2400 A	2149 A	1840 A



### 13.3 NEMA motor ratings

In-line connection

Internally bypassed models	Light	Standard	Heavy
	300%, 10 seconds 50 °C <1000 metres	350%, 30 seconds 50 °C <1000 metres	450%, 30 seconds 50 °C <1000 metres
EMX3-0023B	23 A	21 A	16 A
EMX3-0043B	43 A	39 A	29 A
EMX3-0050B	50 A	46 A	35 A
EMX3-0053B	53 A	53 A	45 A
EMX3-0076B	76 A	65 A	46 A
EMX3-0097B	97 A	79 A	58 A
EMX3-0100B	100 A	84 A	65 A
EMX3-0105B	105 A	105 A	79 A
EMX3-0145B	145 A	124 A	90 A
EMX3-0170B	170 A	141 A	110 A
EMX3-0200B	200 A	159 A	135 A
EMX3-0220B	220 A	180 A	156 A
EMX3-0255B	255 A	205 A	180 A
EMX3-0350B	360 A	302 A	240 A
EMX3-0425B	425 A	360 A	302 A
EMX3-0500B	515 A	384 A	324 A
EMX3-0580B	590 A	426 A	360 A
EMX3-0700B	700 A	515 A	431 A
EMX3-0820B	820 A	605 A	509 A
EMX3-0920B	920 A	673 A	590 A
EMX3-1000B	1000 A	783 A	720 A
<b>Non-bypassed models</b>			
EMX3-0255C	242 A	220 A	160 A
EMX3-0360C	360 A	302 A	242 A
EMX3-0380C	380 A	341 A	272 A
EMX3-0430C	430 A	360 A	302 A
EMX3-0620C	620 A	493 A	394 A
EMX3-0650C	650 A	515 A	414 A
EMX3-0790C	790 A	661 A	527 A
EMX3-0930C	930 A	751 A	597 A
EMX3-1200C	1200 A	1148 A	932 A
EMX3-1410C	1410 A	1200 A	979 A
EMX3-1600C	1600 A	1444 A	1181 A

Inside delta connection

Internally bypassed models	Light	Standard	Heavy
	300%, 10 seconds 50 °C <1000 metres	350%, 30 seconds 50 °C <1000 metres	450%, 30 seconds 50 °C <1000 metres
EMX3-0023B	34 A	31 A	24 A
EMX3-0043B	64 A	58 A	43 A
EMX3-0050B	75 A	69 A	52 A
EMX3-0053B	79 A	79 A	67 A
EMX3-0076B	114 A	97 A	69 A
EMX3-0097B	145 A	118 A	87 A
EMX3-0100B	150 A	126 A	97 A
EMX3-0105B	157 A	157 A	118 A
EMX3-0145B	217 A	186 A	135 A
EMX3-0170B	255 A	211 A	165 A
EMX3-0200B	300 A	238 A	202 A
EMX3-0220B	330 A	270 A	234 A
EMX3-0255B	382 A	307 A	270 A
EMX3-0350B	540 A	453 A	360 A
EMX3-0425B	637 A	540 A	453 A
EMX3-0500B	772 A	576 A	486 A
EMX3-0580B	885 A	639 A	540 A
EMX3-0700B	1050 A	772 A	646 A
EMX3-0820B	1230 A	907 A	763 A
EMX3-0920B	1380 A	1009 A	885 A
EMX3-1000B	1500 A	1174 A	1080 A

Non-bypassed models			
EMX3-0255C	363 A	330 A	240 A
EMX3-0360C	540 A	453 A	363 A
EMX3-0380C	570 A	511 A	408 A
EMX3-0430C	645 A	540 A	453 A
EMX3-0620C	930 A	739 A	591 A
EMX3-0650C	975 A	772 A	621 A
EMX3-0790C	1185 A	991 A	790 A
EMX3-0930C	1395 A	1126 A	895 A
EMX3-1200C	1800 A	1722 A	1398 A
EMX3-1410C	2115 A	1800 A	1468 A
EMX3-1600C	2400 A	2166 A	1771 A

### 13.4 Minimum and Maximum Current Settings

The EMX3's minimum and maximum full load current settings depend on the model:

Model	In-line connection		Inside delta connection	
	Minimum	Maximum	Minimum	Maximum
EMX3-0023B	5 A	23 A	5 A	34 A
EMX3-0043B	9 A	43 A	9 A	64 A
EMX3-0050B	10 A	50 A	10 A	75 A
EMX3-0053B	11 A	53 A	11 A	79 A
EMX3-0076B	15 A	76 A	15 A	114 A
EMX3-0097B	19 A	97 A	19 A	145 A
EMX3-0100B	20 A	100 A	20 A	150 A
EMX3-0105B	21 A	105 A	21 A	157 A
EMX3-0145B	29 A	145 A	29 A	217 A
EMX3-0170B	34 A	170 A	34 A	255 A
EMX3-0200B	40 A	200 A	40 A	300 A
EMX3-0220B	44 A	220 A	44 A	330 A
EMX3-0255B	51 A	255 A	51 A	382 A
EMX3-0255C	51 A	255 A	51 A	382 A
EMX3-0350B	70 A	350 A	70 A	525 A
EMX3-0360C	72 A	360 A	72 A	540 A
EMX3-0380C	76 A	380 A	76 A	570 A
EMX3-0425B	85 A	425 A	85 A	638 A
EMX3-0430C	86 A	430 A	86 A	645 A
EMX3-0500B	100 A	500 A	100 A	750 A
EMX3-0580B	116 A	580 A	116 A	870 A
EMX3-0620C	124 A	620 A	124 A	930 A
EMX3-0650C	130 A	650 A	130 A	975 A
EMX3-0700B	140 A	700 A	140 A	1050 A
EMX3-0790C	158 A	790 A	158 A	1185 A
EMX3-0820B	164 A	820 A	164 A	1230 A
EMX3-0920B	184 A	920 A	184 A	1380 A
EMX3-0930C	186 A	930 A	186 A	1395 A
EMX3-1000B	200 A	1000 A	200 A	1500 A
EMX3-1200C	240 A	1200 A	240 A	1800 A
EMX3-1410C	282 A	1410 A	282 A	2115 A
EMX3-1600C	320 A	1600 A	320 A	2400 A

### 13.5 Dimensions and Weights

EMX3-0023B~EMX3-0105B

EMX3-0145B~EMX3-1000B

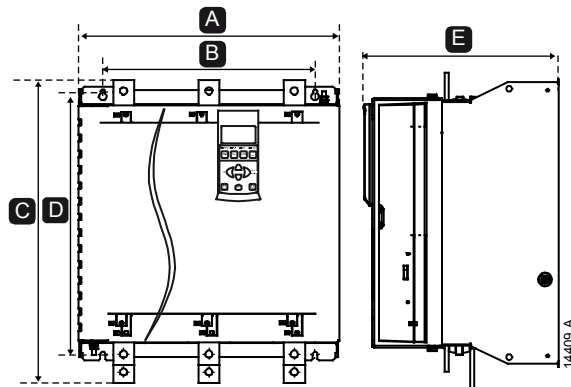
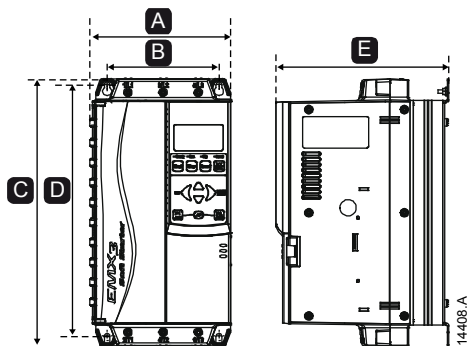

EMX3-0360C~EMX3-1600C

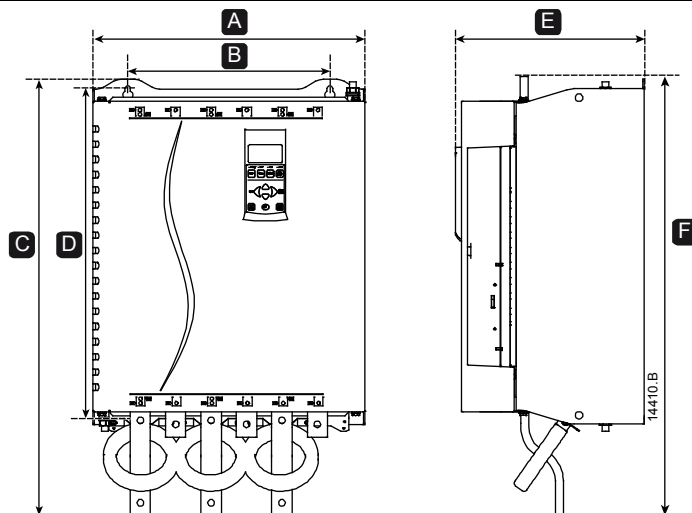

Model	A mm (inch)	B mm (inch)	C mm (inch)	D mm (inch)	E mm (inch)	F mm (inch)	Weight kg (lb)
EMX3-0023B							
EMX3-0043B					192		4.2
EMX3-0050B					(7.6)		(9.3)
EMX3-0053B	156	124	295	278		n/a	
EMX3-0076B	(6.2)	(4.9)	(11.7)	(11.0)			4.5 (9.9)
EMX3-0097B					223		5.0
EMX3-0100B					(8.8)		(11.0)
EMX3-0105B							
EMX3-0145B							14.0 (30.9)
EMX3-0170B	282	250	438	380	250	n/a	14.2 (31.3)
EMX3-0200B	(11.2)	(9.9)	(17.3)	(15.0)	(9.9)		15
EMX3-0220B							(33.1)
EMX3-0255B							26 (57.3)
EMX3-0350B	424 (16.7)	376 (14.9)	440 (17.4)	392 (15.5)	298 (11.8)	n/a	29.4
EMX3-0425B							(64.8)
EMX3-0500B							50.0
EMX3-0580B							(110.2)
EMX3-0700B	433	320	640	600	295	n/a	63.5
EMX3-0820B	(17.1)	(12.6)	(25.2)	(23.7)	(11.7)		(140.0)
EMX3-0920B							64.0
EMX3-1000B							(141.1)
EMX3-0255C	390 (15.4)	320 (12.6)	460 (18.2)	400 (15.8)	279 (11.0)	n/a	23 (50.7)
EMX3-0360C							36
EMX3-0380C							(79.4)
EMX3-0430C	430	320	689	522	300	696	
EMX3-0620C	(17.0)	(12.6)	(27.2)	(20.6)	(11.9)	(27.5)	39.5
EMX3-0650C							(87.1)
EMX3-0790C							
EMX3-0930C							51.5 (113.5)
EMX3-1200C	574	500	856	727	361	862	128.5 (283.3)
EMX3-1410C	(22.6)	(19.7)	(33.8)	(28.7)	(14.3)	(34.0)	130 (286.6)
EMX3-1600C							140 (308.6)

**NOTE**

Dimension C is the height when input and output busbars are at the same end of the unit (top in/top out or bottom in/bottom out).

For UL compliant installation, input and output busbars must be at opposite ends of the unit. Dimension F applies for either top in/bottom out or bottom in/top out configuration.

## 13.6 Specifications

### • Supply

Mains voltage (L1, L2, L3)	
EMX3-xxxx-V4 .....	200 VAC ~ 440 VAC (± 10%)
EMX3-xxxx-V7 .....	380 VAC ~ 690 VAC (± 10%)
Control voltage (A1, A2, A3)	
EMX3-xxxx-xx-C1 (A1, A2).....	110~210 VAC (+ 10% / -15%), 600 mA
EMX3-xxxx-xx-C1 (A2, A3).....	220~440 VAC (+ 10% / -15%), 600 mA
EMX3-xxxx-xx-C2 (A1, A3).....	24 VAC/VDC (± 20%), 100 VA
Mains frequency .....	45 Hz ~ 66 Hz
Rated insulation voltage to earth .....	600 VAC
Rated impulse withstand voltage .....	6 kV
Form designation .....	Bypassed or continuous, semiconductor motor starter form 1

### • Short circuit capability

Coordination with semiconductor fuses.....	Type 2
Coordination with HRC fuses .....	Type 1
EMX3-0023B ~ EMX3-0220B .....	prospective current 65 kA
EMX3-0255B ~ EMX3-1000B .....	prospective current 85 kA
EMX3-0255C ~ EMX3-0930C .....	prospective current 100 kA
EMX3-1200C ~ EMX3-1600C .....	prospective current 85 kA

### • Electromagnetic capability (compliant with EU Directive 2014/35/EU)

EMC Immunity .....	IEC 60947-4-2
EMC Emissions	
EMX3-0023B to EMX3-1000B (Internally bypassed models) .....	IEC 60947-4-2 Class B and Lloyds Marine No 1 Specification
EMX3-0255C to EMX3-1600C (Non-bypassed models) .....	IEC 60947-4-2 Class A <sup>1</sup> and Lloyds Marine No 1 Specification

<sup>1</sup> This product has been designed as Class A equipment. Use of this product in domestic environments may cause radio interference, in which case the user may be required to employ additional mitigation methods.

### • Inputs

Input rating .....	Active 24 VDC, 8 mA approx
Start (C23, C24) .....	Normally Open
Stop (C31, C32) .....	Normally Closed
Reset (C41, C42) .....	Normally Closed
Programmable inputs	
Input A (C53, C54) .....	Normally Open
Input B (C63, C64) .....	Normally Open
Motor thermistor (B4, B5) .....	Trip >3.6 kΩ, reset <1.6 kΩ
PT100 RTD (B6, B7, B8) .....	Accuracy 0 ~ 100 °C ± 0.5 °C, 100 °C ~ 150 °C ± 2 °C, -20 ~ 0 °C ± 2 °C

### • Outputs

Relay outputs .....	10 A @ 250 VAC resistive, 5A @ 250 VAC AC15 pf 0.3
Run relay (23, 24) .....	Normally Open
Programmable outputs	
Relay A (13, 14) .....	Normally Open
Relay B (31, 32, 34) .....	Changeover
Relay C (41, 42, 44).....	Changeover
Analog output (B10, B11) .....	0-20 mA or 4-20 mA (selectable)
Maximum load .....	600 Ω (12 VDC @ 20 mA)
Accuracy .....	± 5%
24 VDC output (P24, COM)	
Maximum load.....	200 mA
Accuracy .....	± 10%

## • Environmental

### Protection

EMX3-0023B ~ EMX3-0105B .....	IP20
EMX3-0145B ~ EMX3-1000B and EMX3-0255C ~ EMX3-1600C .....	IP00
Keypad (when installed with remote mounting kit) .....	IP65 & NEMA12
Operating temperature .....	-10 °C~60 °C, above 40 °C with derating
Storage temperature .....	-25 °C~+ 60 °C
Operating Altitude .....	0~1000 m, above 1000 m with derating
Humidity .....	5%~95% Relative Humidity
Pollution degree .....	Pollution Degree 3
Vibration (EMX3-0023B ~ EMX3-1000B) .....	IEC 60068-2-6

## • Heat Dissipation

During Start .....	4.5 watts per ampere
During Run	
EMX3-0023B ~ EMX3-0053B .....	≤ 39 watts approx
EMX3-0076B ~ EMX3-0105B .....	≤ 51 watts approx
EMX3-0145B ~ EMX3-0220B .....	≤ 120 watts approx
EMX3-0255B ~ EMX3-0500B .....	≤ 140 watts approx
EMX3-0580B ~ EMX3-1000B .....	≤ 357 watts approx
EMX3-0255C ~ EMX3-0930C .....	4.5 watts per ampere approx
EMX3-1200C ~ EMX3-1600C .....	4.5 watts per ampere approx

## • Certification

UL / C-UL .....	UL 508*
EMX3-0023B ~ EMX3-0425B, EMX3-0255C ~ EMX3-1600C .....	UL Listed
EMX3-0500B ~ EMX3-1000B .....	UL Recognised
EMX3-0023B ~ EMX3-0105B .....	IP20 & NEMA1, UL Indoor Type 1
EMX3-0145B ~ EMX3-1600C .....	IP00, UL Indoor Open Type
.....	IP20, when fitted with optional finger guard kit
CE .....	EN 60947-4-2
CCC .....	GB 14048.6
RCM .....	IEC 60947-4-2
Marine (EMX3-0023B ~ EMX3-1000B, internally bypassed models only) .....	
Lloyds .....	Lloyds Marine No 1 Specification
ABS .....	Steel Vessels Rules 2010
RoHS .....	Compliant with EU Directive 2011/65/EU

\* For UL certification additional requirements may apply, depending on the models. For details, refer to *UL Compliant Installation* on page 87.

## • Operational life (internal bypass contacts)

EMX3-0023B ~ EMX3-0105B .....	1,000,000 operations
EMX3-0145B ~ EMX3-1000B .....	100,000 operations



### CAUTION

EMX3-0220B~EMX3-1000B: The contacts on the internal bypass contactors should be checked for wear after the stated number of operations. Periodic servicing/replacements may be required.

## 13.7 UL Compliant Installation

This section details additional requirements and configuration settings for the EMX3 to be UL-compliant. Refer to also *UL Fuse Selection and Short Circuit Ratings* on page 19.

- **Models EMX3-0023B ~ EMX3-0105B**

There is no additional requirement for these models.

- **Models EMX3-0145B ~ EMX3-0425B, EMX3-0255C ~ EMX3-1600C**

Use the recommended pressure terminal/connector kit. Refer to *Terminal/Connector Parts* on page 87 for more information.

- **Models EMX3-0500B ~ EMX3-1000B**

These models are UL recognised components. Separate cable landing busbars may be required within the electrical cabinet when terminating cables sized according to the National Wiring Code (NEC) regulations.

- **Terminal/Connector Parts**

For models EMX3-0145B-EMX3-0425B and EMX3-0255C-EMX3-1600C to be UL compliant, you must use the recommended pressure terminal/connector as detailed in the table below.

Models	FLC (A)	No. of wires	Recommended lugs part No.
EMX3-0145B	145	1	OPHD 95-16
EMX3-0170B	170	1	OPHD 120-16
EMX3-0200B	200	1	OPHD 150-16
EMX3-0220B	220	1	OPHD 185-16
EMX3-0255B	255	1	OPHD 240-20
EMX3-0350B	350	1	OPHD 400-16
EMX3-0425B	425	2	OPHD 185-16
EMX3-0255C	255	1	OPHD 240-20
EMX3-0360C	360		
EMX3-0380C	380		
EMX3-0430C	430	2	1 x 600T-2
EMX3-0620C	620		
EMX3-0650C	650		
EMX3-0790C	790	4	2 x 600T-2
EMX3-0930C	930	3	2 x 600T-2
EMX3-1200C	1200	4	1 x 750T-4
EMX3-1410C	1410		
EMX3-1600C	1600	5	1 x 750T-4 1 x 600T-3

## 13.8 Disposal Instructions

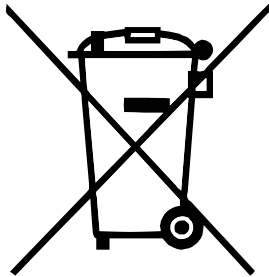

Equipment containing electrical components may not be disposed of together with domestic waste.

It must be collected separately as electrical and electronic waste according to local and currently valid legislation.



## 13.9 Accessories

### Communication Interfaces

EMX3 soft starters support network communication via easy-to-install communications interfaces. Each soft starter can support one communications interface at a time.

Available protocols:

Ethernet (Profinet, Modbus TCP, Ethernet/IP), Profibus, DeviceNet, Modbus RTU, and USB.

### Expansion Cards

The EMX3 offers expansion cards for users requiring additional inputs and outputs or advanced functionality. Each EMX3 can support a maximum of one expansion card.

#### • Input/Output

The input/output expansion card provides the following additional inputs and outputs:

- 2 x digital inputs
- 3 x output relays
- 1 x analog input
- 1 x analog output

#### • RTD/Ground Fault

The RTD/PT100 and ground fault protection card provides the following additional inputs:

- 6 x PT100 RTD inputs
- 1 x ground fault input

To use ground fault protection a 1000:1, 5 VA current transformer is also required.

### Finger Guard Kit

Finger guards may be specified for personnel safety. Finger guards fit over the soft starter terminals to prevent accidental contact with live terminals. Finger guards provide IP20 protection when correctly installed.



#### NOTE

Finger guards can be used on soft starter models EMX3-0145B~EMX3-1000B (internally bypassed models only). Different kits are required for different models.

### Keypad Mounting Kit

The keypad mounting kit allows remote mounting of the keypad up to 3 m away from the soft starter. Different kits are available with two or three metre cables.

### PC Software

WinMaster PC software provides monitoring, programming and control of up to 99 soft starters.

A Modbus or USB communication module is required for each starter to use WinMaster.

## 13.10 Parameter Values

If you require assistance from your supplier or a service technician, please note all parameter settings in the table below.

1	Motor Data-1	User Set 1	User Set 2
1A	Motor Full Load Current		
1B	Locked Rotor Time		
1C	Locked Rotor Current		
1D	Motor Service Factor		
<b>2</b>	<b>Start/Stop Modes-1</b>		
2A	Start Mode		
2B	Start Ramp Time		
2C	Initial Current		
2D	Current Limit		
2E	Adaptive Start Profile		
2F	Kickstart Time		
2G	Kickstart Level		
2H	Stop Mode		
2I	Stop Time		
2J	Adaptive Stop Profile		
2K	Adaptive Control Gain		
2L	Brake Torque		
2M	Brake Time		
<b>3</b>	<b>Auto-Start/Stop</b>		
3A	Auto-Start Type		
3B	Auto-Start Time		
3C	Auto-Stop Type		
3D	Auto-Stop Time		
<b>4</b>	<b>Protection Settings</b>		
4A	Excess Start Time		
4B	Excess Start Time-2		
4C	Undercurrent		
4D	Undercurrent Delay		
4E	Instantaneous Overcurrent		
4F	Instantaneous Overcurrent Delay		
4G	Phase Sequence		
4H	Current Imbalance		
4I	Current Imbalance Delay		
4J	Frequency Check		
4K	Frequency Variation		
4L	Frequency Delay		
4M	Restart Delay		
4N	Motor Temperature Check		
4O	Ground Fault Level		
4P	Ground Fault Delay		
4Q	Reserved		
4R	Reserved		
4S	Reserved		
4T	Reserved		
<b>5</b>	<b>Auto-Reset Trips</b>		
5A	Auto-Reset Action		
5B	Maximum Resets		

5C	<i>Reset Delay Groups A&amp;B</i>
5D	<i>Reset Delay Group C</i>
<b>6</b>	<b>Inputs</b>
6A	<i>Input A Function</i>
6B	<i>Input A Name</i>
6C	<i>Input A Trip</i>
6D	<i>Input A Trip Delay</i>
6E	<i>Input A Initial Delay</i>
6F	<i>Input B Function</i>
6G	<i>Input B Name</i>
6H	<i>Input B Trip</i>
6I	<i>Input B Trip Delay</i>
6J	<i>Input B Initial Delay</i>
6K	<i>Input C Function</i>
6L	<i>Input D Function</i>
6M	<i>Remote Reset Logic</i>
6N	<i>Analog Input Trip</i>
6O	<i>Analog Input Scale</i>
6P	<i>Analog Trip Point</i>
6Q	<i>Local/Remote</i>
6R	<i>Comms in Remote</i>
<b>7</b>	<b>Outputs</b>
7A	<i>Relay A Function</i>
7B	<i>Relay A On Delay</i>
7C	<i>Relay A Off Delay</i>
7D	<i>Relay B Function</i>
7E	<i>Relay B On Delay</i>
7F	<i>Relay B Off Delay</i>
7G	<i>Relay C Function</i>
7H	<i>Relay C On Delay</i>
7I	<i>Relay C Off Delay</i>
7J	<i>Relay D Function</i>
7K	<i>Relay E Function</i>
7L	<i>Relay F Function</i>
7M	<i>Low Current Flag</i>
7N	<i>High Current Flag</i>
7O	<i>Motor Temperature Flag</i>
7P	<i>Analog Output A</i>
7Q	<i>Analog A Scale</i>
7R	<i>Analog A Maximum Adjustment</i>
7S	<i>Analog A Minimum Adjustment</i>
7T	<i>Analog Output B</i>
7U	<i>Analog B Scale</i>
7V	<i>Analog B Maximum Adjustment</i>
7W	<i>Analog B Minimum Adjustment</i>
<b>8</b>	<b>Display</b>
8A	<i>Language</i>
8B	<i>F1 Button Action</i>
8C	<i>F2 Button Action</i>
8D	<i>Display A or kW</i>
8E	<i>User Screen - Top Left</i>

8F	User Screen - Top Right
8G	User Screen - Bottom Left
8H	User Screen - Bottom Right
8I	Graph Data
8J	Graph Timebase
8K	Graph Maximum Adjustment
8L	Graph Minimum Adjustment
8M	Current Calibration
8N	Mains Reference Voltage
8O	Voltage Calibration
<b>9</b>	<b>Motor Data-2</b>
9A	Dual Thermal Model
9B	Motor FLC-2
9C	Locked Rotor Time-2
9D	Locked Rotor Current-2
9E	Motor Service Factor-2
<b>10</b>	<b>Start/Stop Modes-2</b>
10A	Start Mode-2
10B	Start Ramp-2
10C	Initial Current-2
10D	Current Limit-2
10E	Adaptive Start Profile-2
10F	Kickstart Time-2
10G	Kickstart Level-2
10H	Stop Mode-2
10I	Stop Time-2
10J	Adaptive Stop Profile-2
10K	Adaptive Control Gain-2
10L	Brake Torque-2
10M	Brake Time-2
<b>11</b>	<b>RTD Temperatures</b>
11A	RTD/PT100 A °C
11B	RTD/PT100 B °C
11C	RTD/PT100 C °C
11D	RTD/PT100 D °C
11E	RTD/PT100 E °C
11F	RTD/PT100 F °C
11G	RTD/PT100 G °C
<b>12</b>	<b>Slip-Ring Motors</b>
12A	Motor Data-1 Ramp
12B	Motor Data-2 Ramp
12C	Changeover Time
12D	Slip Ring Retard
<b>15</b>	<b>Advanced</b>
15A	Access Code
15B	Adjustment Lock
15C	Emergency Run
15D	Shorted SCR Action
<b>16</b>	<b>Protection Action</b>
16A	Motor Overload
16B	Excess Start Time

16C	<i>Undercurrent</i>
16D	<i>Instantaneous Overcurrent</i>
16E	<i>Current Imbalance</i>
16F	<i>Frequency</i>
16G	<i>Input A Trip</i>
16H	<i>Input B Trip</i>
16I	<i>Motor Thermistor</i>
16J	<i>Starter Communication</i>
16K	<i>Network Communication</i>
16L	<i>Heatsink Overtemperature</i>
16M	<i>Battery/Clock</i>
16N	<i>Ground Fault</i>
16O	<i>RTD/PT100 A</i>
16P	<i>RTD/PT100 B</i>
16Q	<i>RTD/PT100 C</i>
16R	<i>RTD/PT100 D</i>
16S	<i>RTD/PT100 E</i>
16T	<i>RTD/PT100 F</i>
16U	<i>RTD/PT100 G</i>
16V	<i>Reserved</i>
16W	<i>Reserved</i>
16X	<i>Low Control Volts</i>
<b>20</b>	<b>Restricted</b>

## 14. Busbar Adjustment Procedure

The busbars on non-bypassed models EMX3-0360C ~ EMX3-1600C can be adjusted for top or bottom input and output as required.



### NOTE

Many electronic components are sensitive to static electricity. Voltages so low that they cannot be felt, seen or heard, can reduce the life, affect performance, or completely destroy sensitive electronic components. When performing service, proper ESD equipment should be used to prevent possible damage from occurring.

All units are manufactured with input and output busbars at the bottom of the unit as standard. The input and/or output busbars can be moved to the top of the unit if required.

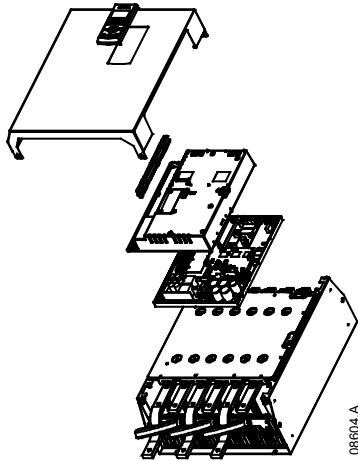

1. Remove all wiring and links from the soft starter before dismantling the unit.
2. Remove the unit cover (4 screws).
3. Remove the keypad faceplate, then gently remove the keypad (2 screws).
4. Remove the control terminal plugs.
5. Gently fold the main plastic away from the starter (12 screws).
6. Unplug the keypad loom from CON 1 (see note).
7. Label each SCR firing loom with the number of the corresponding terminal on the backplane PCB, then unplug the looms.
8. Unplug the thermistor, fan and current transformer wires from the model board.
9. Remove the plastic tray from the starter (four screws).



### NOTE

Remove the main plastic slowly to avoid damaging the keypad wiring loom which runs between the main plastic and the backplane PCB.

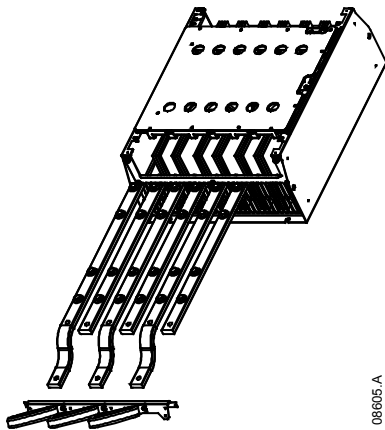

10. Unscrew and remove the magnetic bypass plates (models EMX3-0620C to EMX3-1600C only).
11. Remove the current transformer assembly (three screws).
12. Identify which busbars are to be moved. Remove the bolts holding these busbars in place then slide the busbars out through the bottom of the starter (four bolts per busbar).

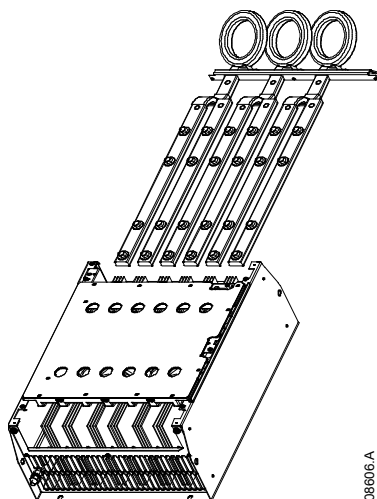

13. Slide the busbars in through the top of the starter. For input busbars, the short curved end should be outside the starter. For output busbars, the unthreaded hole should be outside the starter.
14. Replace the dome washers with the flat face towards the busbar, then tighten the bolts holding the busbars in place to 20 Nm.
15. Place the current transformer assembly over the input busbars and screw the assembly to the body of the starter (see note).
16. Run all wiring to the side of the starter and secure with cable ties.

**NOTE**

If moving the input busbars, the current transformers (CTs) must also be reconfigured.

1. Label the CTs L1, L2 and L3 (L1 is leftmost when looking from the front of the starter). Remove the cable ties and unscrew the CTs from the bracket.
2. Move the CT bracket to the top of the starter. Position the CTs for the correct phases, then screw the CTs to the bracket. For models EMX3-0360C ~ EMX3-0930C, the CTs must be placed on an angle (the left hand legs of each CT will be on the top row of holes and the right hand legs will be on the bottom tabs).

#### New Zealand

123 Wrights Road, PO Box 80208, Christchurch 8440, New Zealand

**T** +64 3 338 8280 **F** +64 3 338 8104

#### China

203-1 JH Plaza, 2008 Huqingping Road, Shanghai 201702, China

**T** +86 21 5877 5178 **F** +86 21 5877 6378

#### Germany

Borsigstraße 6, 48324 Sendenhorst, Germany

**T** +49 2526 93880 0 **F** +49 2526 93880 100

#### Middle East

10th Floor, Jumeirah Lakes Towers, Dubai, UAE

**T** +971 4279 8349 **F** +971 4279 8399

#### North America

2528 Lovi Road, Building 2-2A, Freedom, PA 15042, USA

**T** 855 928 2666 (855 AUCOM NA), +1 724 987 4952 **F** +1 724 510 3005

<http://my.aucom.com>

**RIGHT FROM  
THE START**

**AUCom**  
MOTOR CONTROL SPECIALISTS