



**AVIBRO®**

**PV-A**

TEKNİK KATALOG  
TECHNICAL CATALOGUE **2020**

TEKNOLOJİ / TECHNOLOGY →

KALİTE / QUALITY →

PERFORMANS / PERFORMANCE →

VERİMLİLİK / PRODUCTIVITY →

GÜÇ / POWER →

TASARIM / DESIGN →

YENİLİK / INNOVATION →

TECRÜBE / KNOW-HOW →

SERVİS / SERVICE →

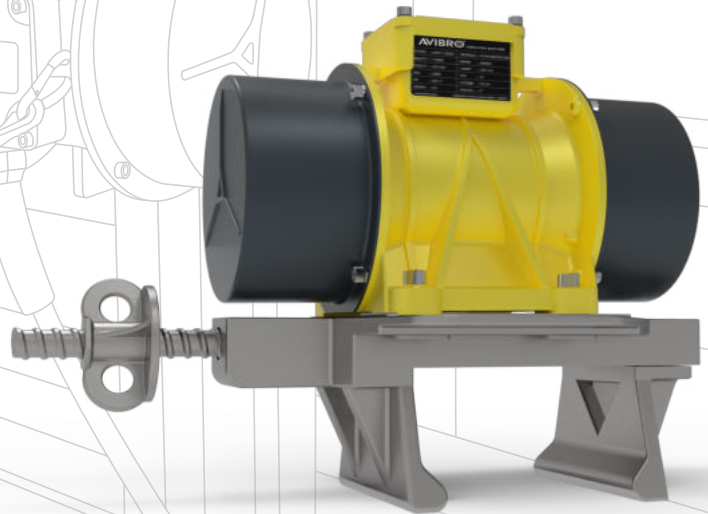

PV-A 50 Hz - 3000 rpm / 200 Hz 6000 rpm

Açıklama / Description		Mekanik Özellikler / Mechanical Specifications				Elektriksel Özellikler / Electrical Specifications				
Model Type	Gövde Size	Santrüfjü Kuvveti Centrifugal Force		(*)Statik Moment Statical Moment (m <sup>1</sup> )	Ağırlık Weight	Giriş Gücü Input Power	Nominal Akım Nom. Current	Gerilim Voltage	Frekans Frequency	Devir rpm
		(Kg/F)	(kN)	(Kgmm)	(Kg)					
PV-A 400/42	20	392	3,84	9,7	8,3	400	8,7	42-55~	200	6000
PV-A 400/230	20	311	3,05	30,9	8,3	400	113,6	230~	50	3000
PV-A 400/400	20	387	3,79	38,4	8,3	400	1,1	400~	50	3000
PV-A 400/115	20	374	3,66	9,2	8,3	400	3,4	115~	200	6000

(\*) Working moment = 2x static moment



## Değişken Frekanslı Vibrasyon Motorları

> PV-A serisi ürünler özellikle brüt beton uygulamaları için beton; Plywood ve çelik kalıplarda, perde beton, viyadükler ve benzeri demir donatısının yoğun olduğu yumuşak betonun ayrılmaya, (segregasyon) uğramadan sıkıştırılması için geliştirilmiş ideal bir vibrasyon motorudur.

- > PV-A serisi vibrasyon motorları,
  - Bina Tünel kalıplarında
  - Kolon, viyadük ve perde beton kalıplarında
  - Üst yapı ve alt yapıda, beton boru kalıplarında
  - Vibrasyon masalarında

Tüm yoğun donatılı ahşap ve çelik beton kalıplarında güvenilir, uzun ömürlü, rahat ve problemsiz taze betonun sıkıştırılması için kullanılır.



## Variable Frequency Vibration Motors

> PV-A series products are especially for gross concrete applications; It is an ideal vibration motor developed for the compression of soft concrete in which plywood and steel molds, curtain concrete, viaducts and similar iron reinforcement is dense without segregation.

- > PV-A series vibration motors,
  - Building tunnel formworks,
  - Column, viaduct and curtain concrete molds,
  - Superstructure and infrastructure,
  - In concrete pipe molds,
  - On vibration tables,
  - All densely reinforced wooden and steel concrete molds,

It is used for compacting fresh, reliable, long-lasting, comfortable and problem-free concrete.

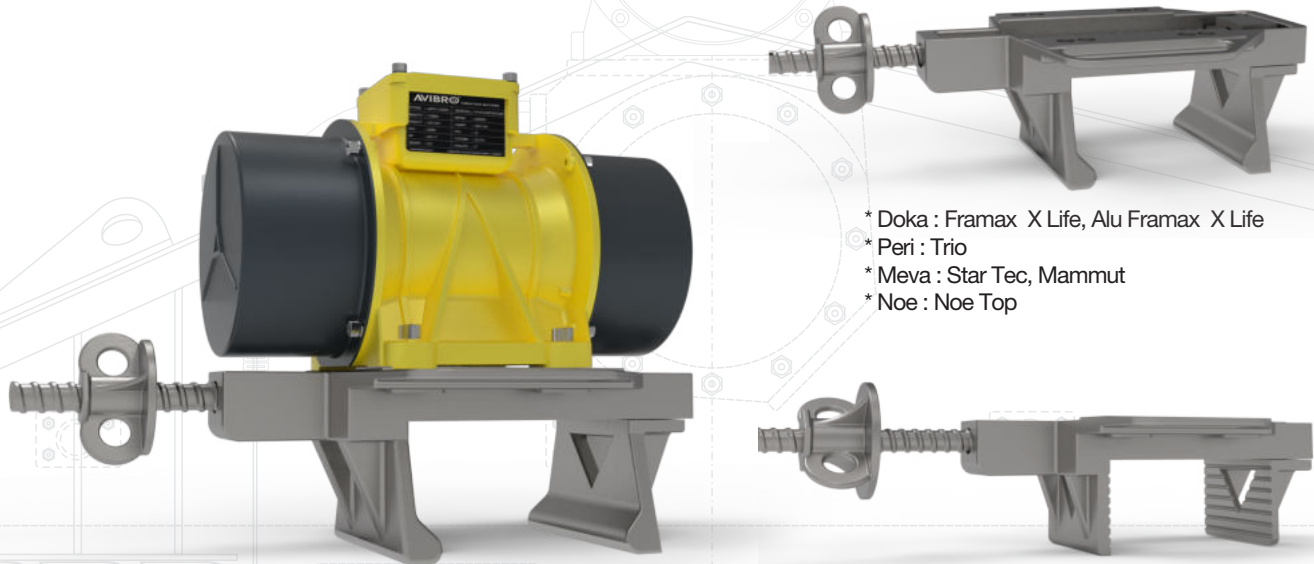

- \* Doka : Framax X Life, Alu Framax X Life
- \* Peri : Trio
- \* Meva : Star Tec, Mammut
- \* Noe : Noe Top

- \* Doka : H 20, Top 50, Ff 20
- \* Peri : VT 20K, GT 24, VARIO GT 24
- \* Hünnebeck : H 20, R 24, GF 24, ES 24
- \* Meva : H 20
- \* Noe : H 20
- \* Paschal : H 20

PV-A 50 Hz - 3000 rpm / 200 Hz 6000 rpm

	Model Type	Gövde Size	Fig.	Gövde Ölçüleri - Overall Dimensions (mm)														
				A	B	C	D	E	ØF	R	L	M	ØK	K <sup>1</sup>	G	S	N	
three-phase	PV-A 400/42	20	B	289	150,5	134	77,5	172	128	150	90	125	13,5	4	--	14	27	71,5
	PV-A 400/230	20	B	289	150,5	134	77,5	172	128	150	90	125	13,5	4	--	14	27	71,5
	PV-A 400/400	20	B	289	150,5	134	77,5	172	128	150	90	125	13,5	4	--	14	27	71,5
	PV-A 400/115	20	B	289	150,5	134	77,5	172	128	150	90	125	13,5	4	--	14	27	71,5

Fig. B

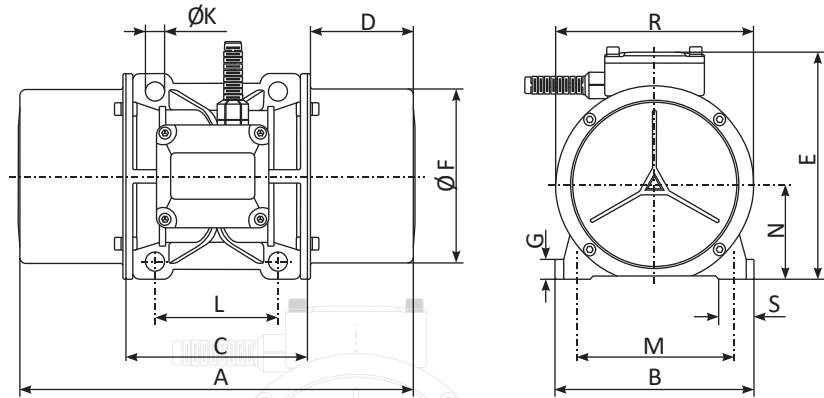

## PV-AF - Elektronik Frekans Konvertörleri - Variable Electronical Frequency Converters

Model Type	Çalışma Voltajı Operating Voltage	Şebeke Akımı Current Input	Çıkış Voltajı Voltage Output	Çıkış Akımı Current Output	Priz Sayısı Number Of Sockets
PV-AF 55/4	380-400V / 50 Hz	6 Amp.	42-55 V	55 Amp.	4
PV-AF 80/6	380-400V / 50 Hz	9 Amp.	42-55 V	80 Amp.	6
PV-AF 110/8	380-400V / 50 Hz	16 Amp.	42-55 V	110 Amp.	8
PV-AF 130/10	380-400V / 50 Hz	20 Amp.	42-55 V	130 Amp.	10



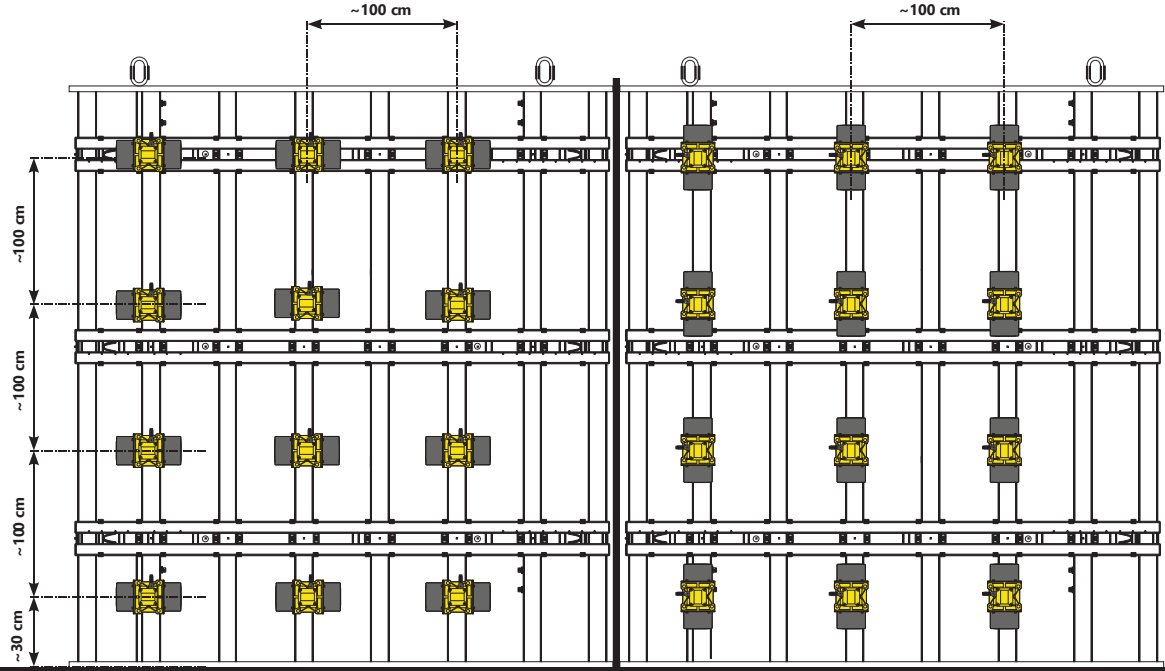

Şekil 1: Plywood Ahşap ve Çelik beton kalıplarına sistematik vibrasyon motoru yerleştirme  
Example 1: Placement of vibrations on wooden concrete moulds

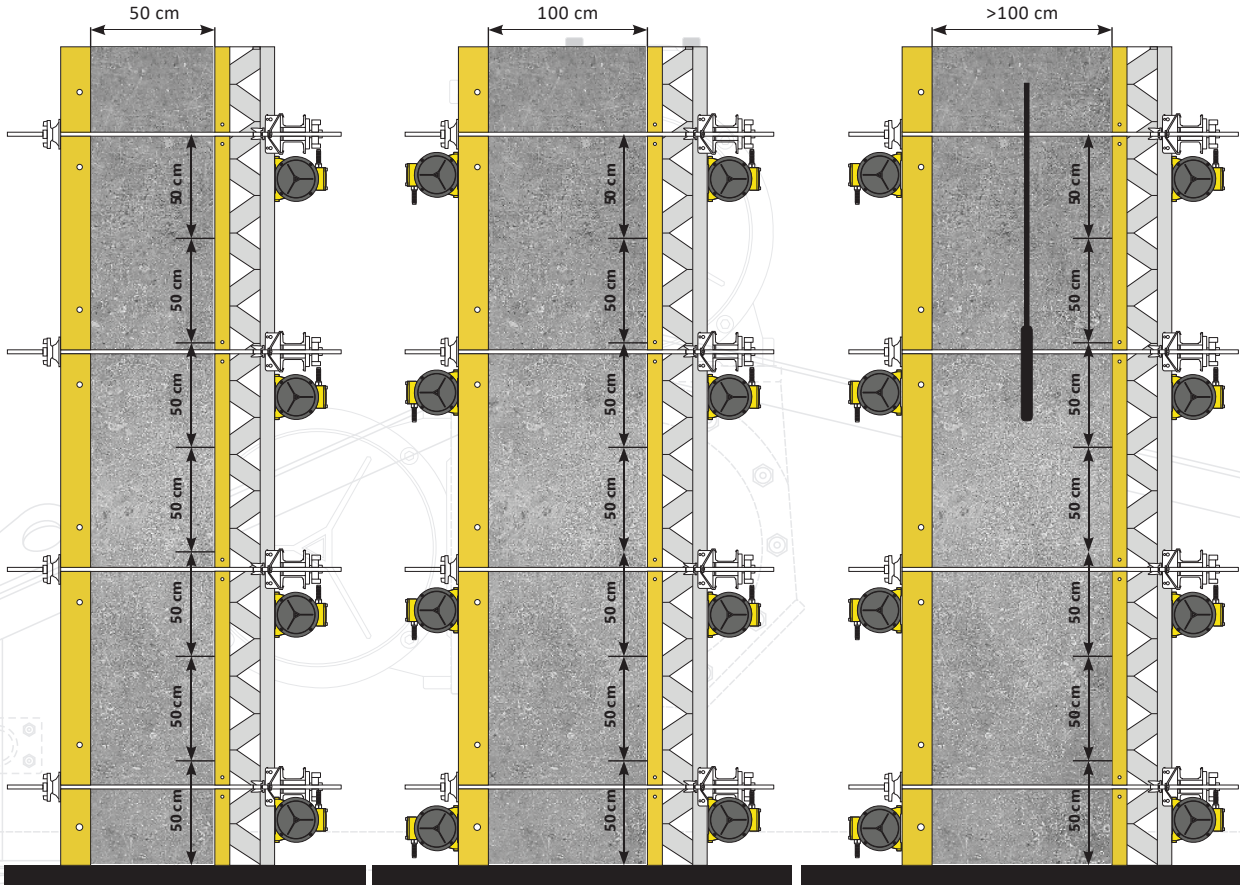

Şekil 3: PV-A serisi vibrasyon motorunun etkili sıkıştırma derinliği.  
Example 3: Placement of vibrations and efficient depth of compacting.

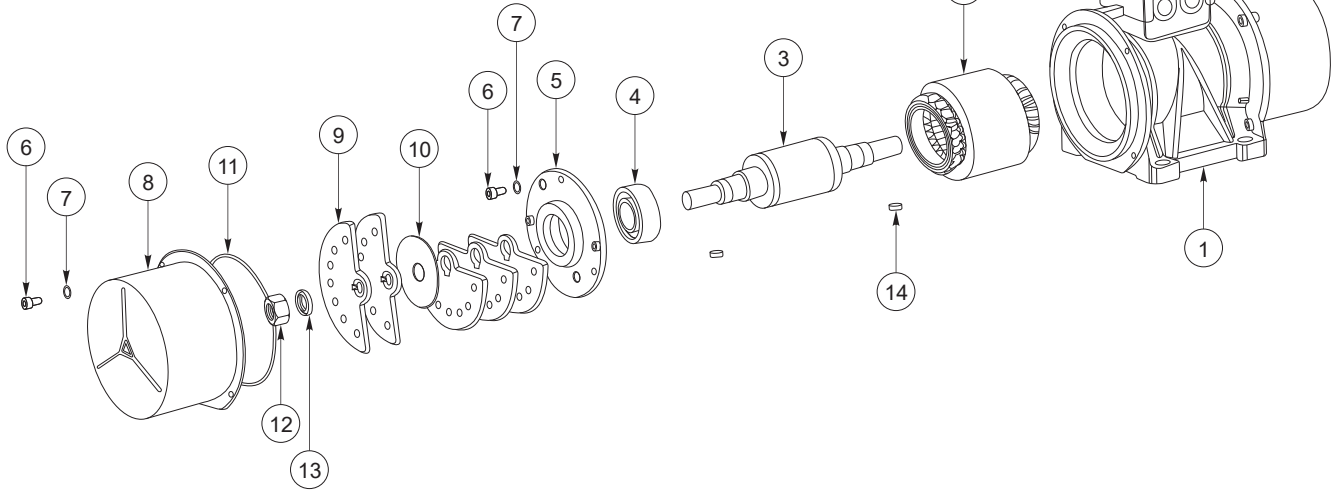
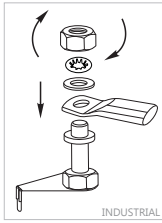



### Açıklama / Description

No Pos.	Kod Code	Parça Adı	Description	Adet Q.Ty
1	A001002	Gövde	Body	1
2	A007001	Stator	Stator	1
3	A004004	Rotor+Mil	Rotor	1
4	A003202	Rulman	Bearing	2
5	A002002	Rulman Kapağı	Bearing Cover	1
6	E009022	DIN912 - M5x12 Imbus Cıvata	DIN912 - M5x12 Screw	21
7	A009011	M5 Tırtırlı Rondela	M5 Washer	19
8	A005002	Ağırlık Koruma Tası	End Cover	2
9	A006066	Ø14 Ağırlık	Ø14 Weight	10
10	A008069	Ağırlık Ayar Derecesi	Adjusting Plate	2
11	A008024	Ø120,5x2,62 O-Ring	Ø120,5x2,62 O-Ring	2
12	A009019	M14 Altıköşe Somun	M14 Nut	2
13	A009020	M14 Tırtırlı Rondela	M14 Washer	2
14	E009001	4x4x8 Kama	Key A4x4x8	2
15	E008051	Klemens	Terminal Block	1
16	A008022	Ø78x3 O-Ring	Ø78x3 O-Ring	1
17	A008006	Klemens Kapağı	Terminal Cover	1
18	A008004	M16x1,5 Rekor	M16x1,5 Cable Grip	1
19				
20				
21				
22				

# PV-A

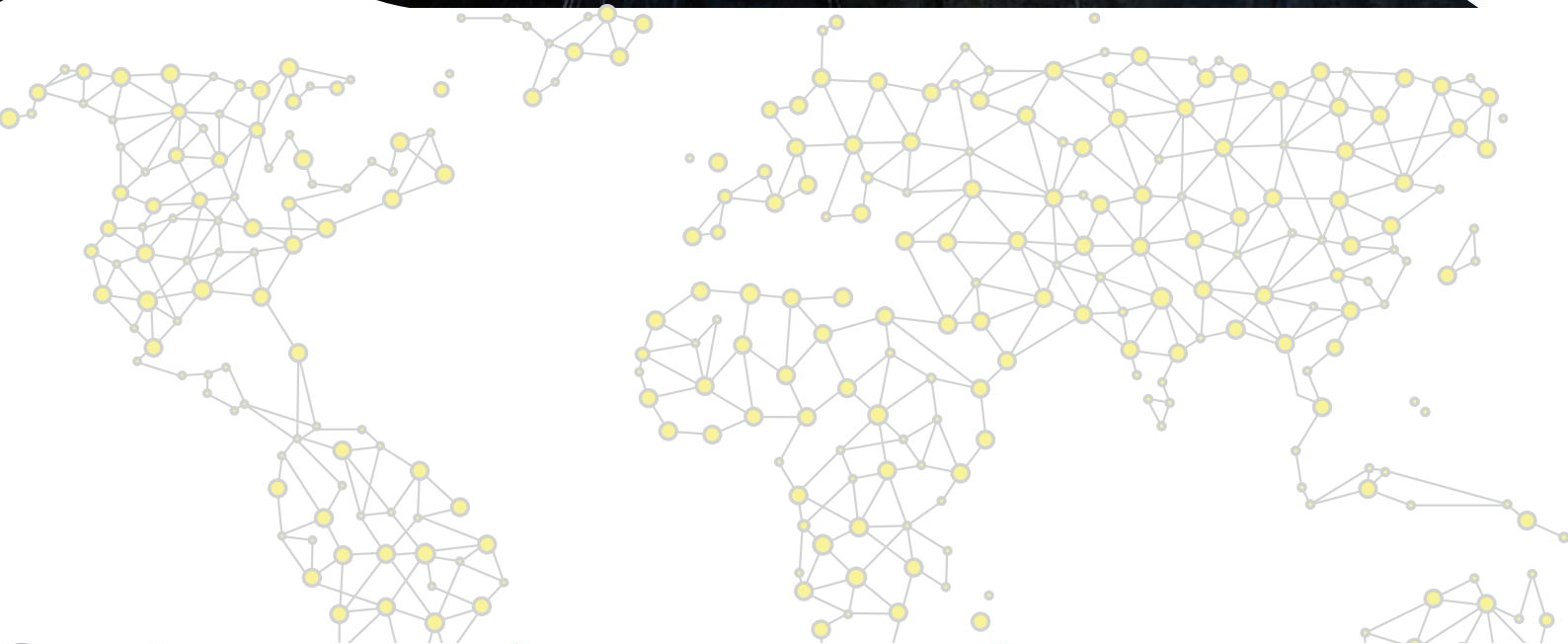
**FAMCO**  
هایپر صنعت



 [www.famcocorp.com](http://www.famcocorp.com)

 E-mail: [info@famcocorp.com](mailto:info@famcocorp.com)

 @famco\_group

 Tel: +۹۰۲۱-۴۸۰۰۰۰۴۹

 Fax: +۹۰۲۱-۴۴۹۹۴۶۴۲

تهران، کیلومتر ۲۱ بزرگراه لشگری (جاده مخصوص کرج)

روبروی پالایشگاه نفت پارس، پلاک ۱۲