



DIPLOMATIC
HYDRAULICS

41 630/107 ED



DSC*

HYDRAULICALLY OPERATED DIRECTIONAL CONTROL VALVE

SUBPLATE MOUNTING

DSC3 ISO 4401-03 (CETOP 03)

DSC5 ISO 4401-05 (CETOP R05)
(available soon)

p max (see performances table)

Q nom (see performances table)

DSC3 MOUNTING SURFACE

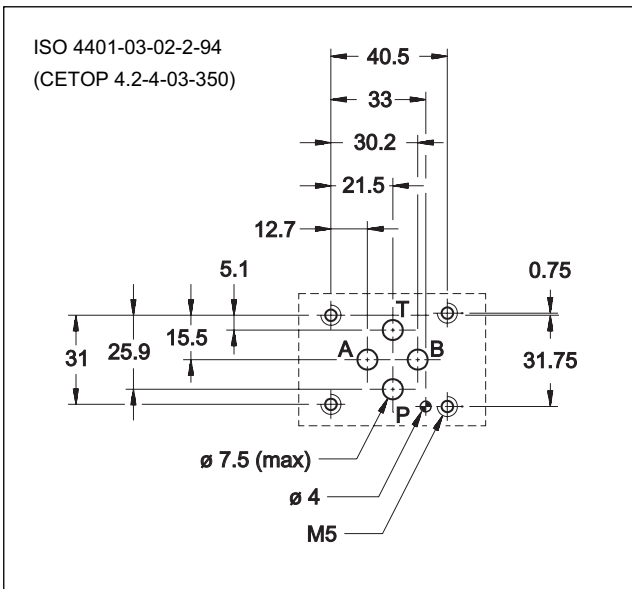

DSC5 MOUNTING SURFACE

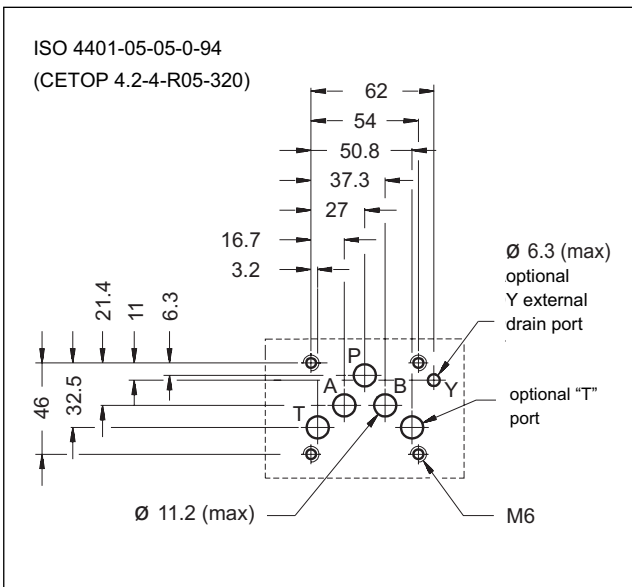

OPERATING PRINCIPLE

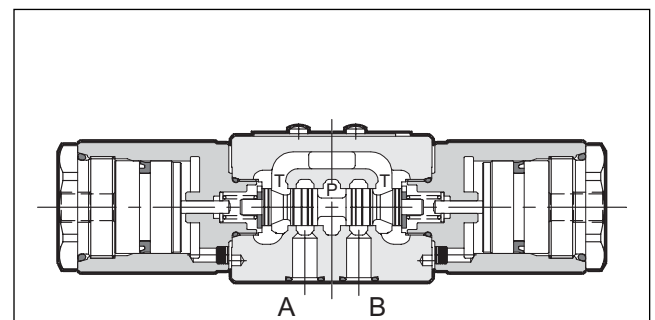

- The DSC* are hydraulically operated (1) directional control valves, available with 3 or 4 ways with several interchangeable spools (2) and with mounting interface according to ISO 4401 (CETOP RP121H) standards.
- The valve body (3) is made with high strength iron castings provided with wide internal passages in order to minimize the flow pressure drop.
- It is available with 2 or 3 positions with return spring, or with two positions with mechanical retention.



1 - IDENTIFICATION CODE

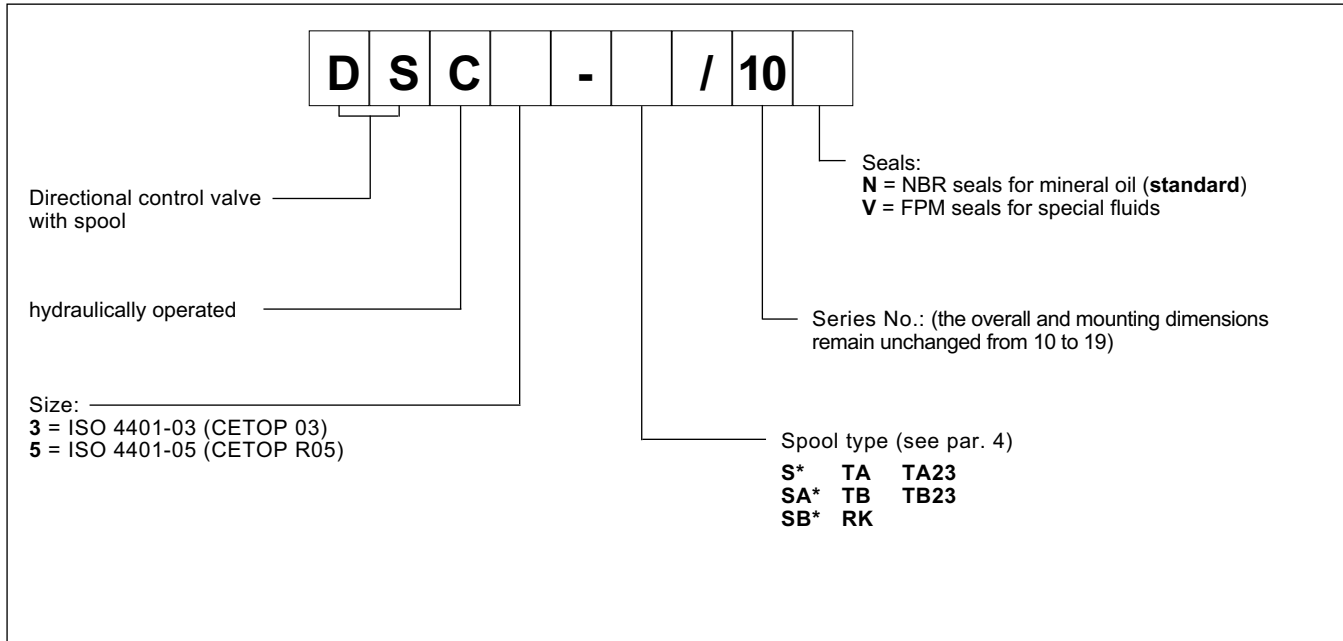

2 - PERFORMANCES (with mineral oil of viscosity 36 cSt at 50°C)

			DSC3	DSC5
Maximum working pressure:				
- P A B ports		bar	350	
- T port			25	
Piloting pressure	min max	bar	15 (see NOTE 1) 210	
Nominal flow rate		l/min	75	
Ambient temperature range		°C	-20 / +50	
Fluid temperature range		°C	-20 / +80	
Fluid viscosity range		cSt	10 ÷ 400	
Recommended viscosity		cSt	25	
Fluid contamination degree			according to ISO 4406:1999 class 20/18/15	
Mass	single operation valve double operation valve	kg	1,3 1,7	

NOTE 1: The piloting pressure must be higher than the counterpressure on T port, of 15 bar at least.

3 - HYDRAULIC FLUIDS

Use mineral oil-based hydraulic fluids HL or HM type, according to ISO 6743-4. For these fluids, use NBR seals (code N).
For fluids HFDR type (phosphate esters) use FPM seals (code V).
For the use of other fluid types such as HFA, HFB, HFC, please consult our technical department.

Using fluids at temperatures higher than 80 °C causes a faster degradation of the fluid and of the seals characteristics.
The fluid must be preserved in its physical and chemical characteristics.



4 - SPOOL TYPE

Type S*:
2 operations - 3 positions
with spring centering

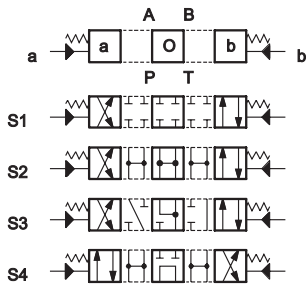

Type SA*:
1 operation side A
2 positions (central + external)
with spring centering

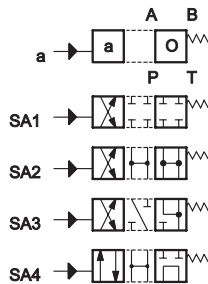

Type SB*:
1 operation side B
2 positions (central + external)
with spring centering

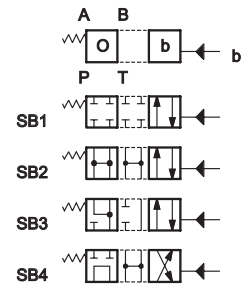

Type TA:
1 operation side A
2 external positions
with return spring

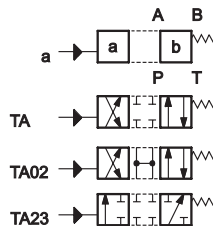

Type TB:
1 operation side B
2 external positions
with return spring

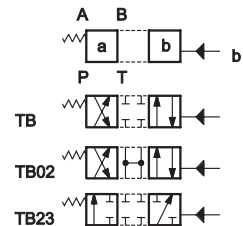

Type RK:
2 operations - 2 positions
with mechanical retention

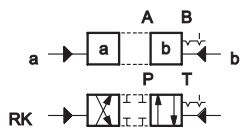

Besides the diagrams shown, which are the most frequently used, other special versions are available: consult our technical department for their identification and operating limits.



5 - PRESSURE DROPS Δp -Q (values obtained with viscosity 36 cSt at 50 °C)

5.1 - Pressure drops Δp -Q DSA3

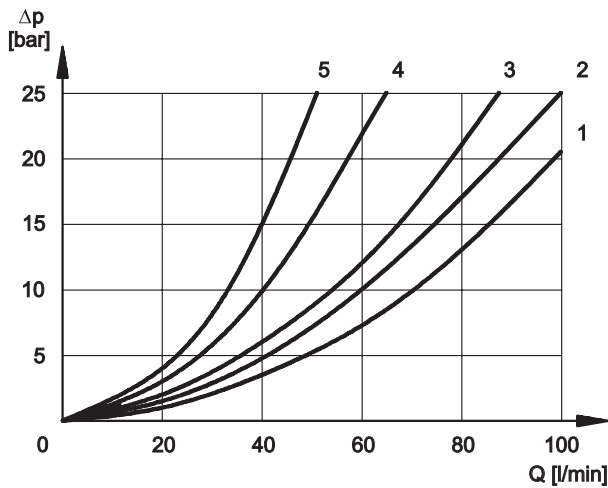

PRESSURE DROPS WITH VALVE IN ENERGIZED POSITION

SPOOL TYPE	FLOW DIRECTION			
	P-A	P-B	A-T	B-T
	CURVES ON GRAPH			
S1, SA1, SB1	2	2	3	3
S2, SA2, SB2	1	1	3	3
S3, SA3, SB3	3	3	1	1
S4, SA4, SB4	5	5	5	5
TA, TB	2	2	2	2
TA02, TB02	2	2	2	2
TA23, TB23	3	3		
RK	2	2	2	2

PRESSURE DROPS WITH VALVE IN DE-ENERGIZED POSITION

SPOOL TYPE	FLOW DIRECTION				
	P-A	P-B	A-T	B-T	P-T
	CURVES ON GRAPH				
S2, SA2, SB2					2
S3, SA3, SB3			3	3	
S4, SA4, SB4					4



5.2 - Pressure drops Δp -Q DSC5

PRESSURE DROPS WITH VALVE IN ENERGIZED POSITION

SPOOL TYPE	FLOW DIRECTION			
	P-A	P-B	A-T	B-T
	CURVES ON GRAPH			
S1, SA1, SB1				
S2, SA2, SB2				
S3, SA3, SB3				
S4, SA4, SB4				
TA, TB				
TA02, TB 02				
TA23, TB23				
RK				

PRESSURE DROPS WITH VALVE IN DE-ENERGIZED POSITION

SPOOL TYPE	FLOW DIRECTION				
	P-A	P-B	A-T	B-T	P-T
	CURVES ON GRAPH				
S2, SA2, SB2					
S3, SA3, SB3					
S4, SA4, SB4					



6 - OPERATING LIMITS

The curves define the flow rate operating fields according to the valve pressure of the different versions. The values have been obtained according to ISO 6403 norm, with mineral oil viscosity 36 cSt at 50 °C and filtration according to ISO 4406:1999 class 18/16/13.

6.1 - Operating limits DSC3

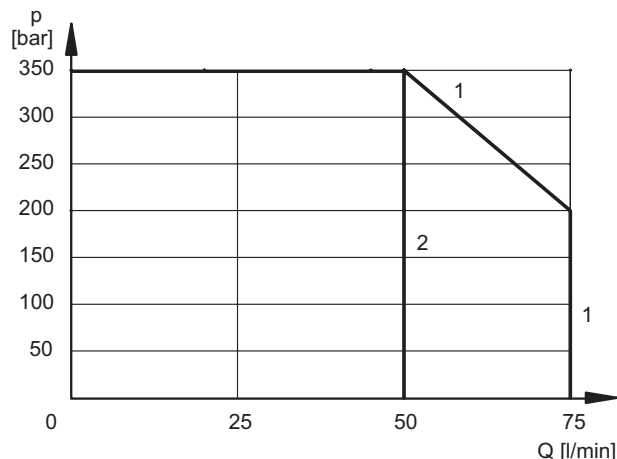

SPOOL TYPE	CURVE	
	P-A	P-B
S1,SA1,SB1	1	1
S2, SA2, SB2	2	2
S3, SA3, SB3	1	1
S4, SA4, SB4	2	2

SPOOL TYPE	CURVE	
	P-A	P-B
TA, TB	1	1
TA02, TB02	1	1
TA23, TB23	2	2
RK	1	1

6.2 - Operating limits DSC5

SPOOL TYPE	CURVE	
	P-A	P-B
S1,SA1,SB1		
S2, SA2, SB2		
S3, SA3, SB3		
S4, SA4, SB4		

SPOOL TYPE	CURVE	
	P-A	P-B
TA, TB		
TA02, TB02		
TA23, TB23		
RK		

7 - INSTALLATION

Configurations with centering and return springs can be mounted in any position; type RK valves - without springs and with mechanical detent - must be mounted with the longitudinal axis horizontal. Valve fixing is by means of screws or tie rods, with the valve mounted on a lapped surface, with values of planarity and smoothness that are equal to or better than those indicated in the drawing. If the minimum values of planarity and/or smoothness are not met, fluid leakage between valve and mounting surface can easily occur.

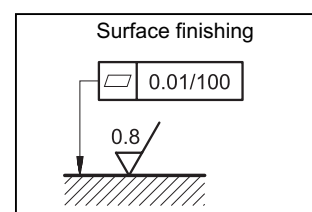



8 - OVERALL AND MOUNTING DIMENSIONS DSC3

DSC3 - S*
DSC3 - RK

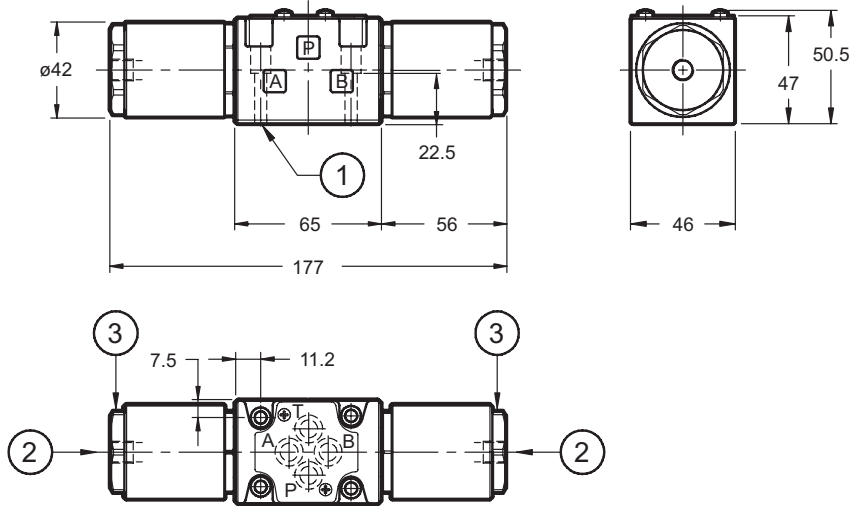

DSC3 - TA
DSC3 - SA*
DSC3 - TA23

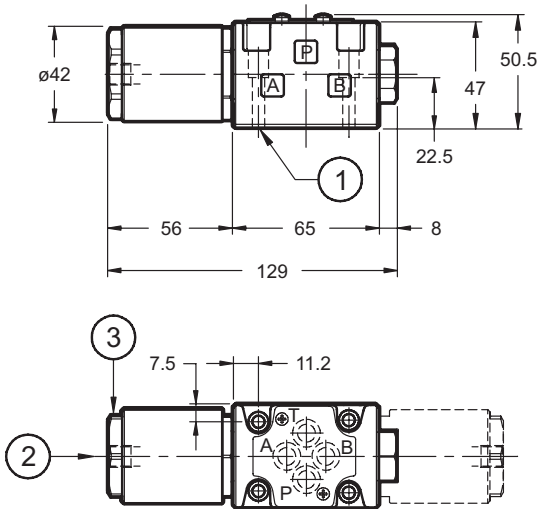

dimensions in mm

1	Mounting surface with sealing rings
2	1/4" BSP connection for hydraulic operation
3	Hexagon: spanner 36 Tightening torque 35 - 40 Nm

Valve fastening	4 bolts TCEI M5x30 (recommended class 12.9)
Tightening torque:	5 Nm (bolts A 8.8) 8 Nm (bolts A 12.9)
Threads of mounting holes:	M5x10
Sealing rings:	4 OR type 2037 (9.25x 1.78) - 90 Shore

operation position configuration SB*, TB and TB23



9 - OVERALL AND MOUNTING DIMENSIONS DSC5

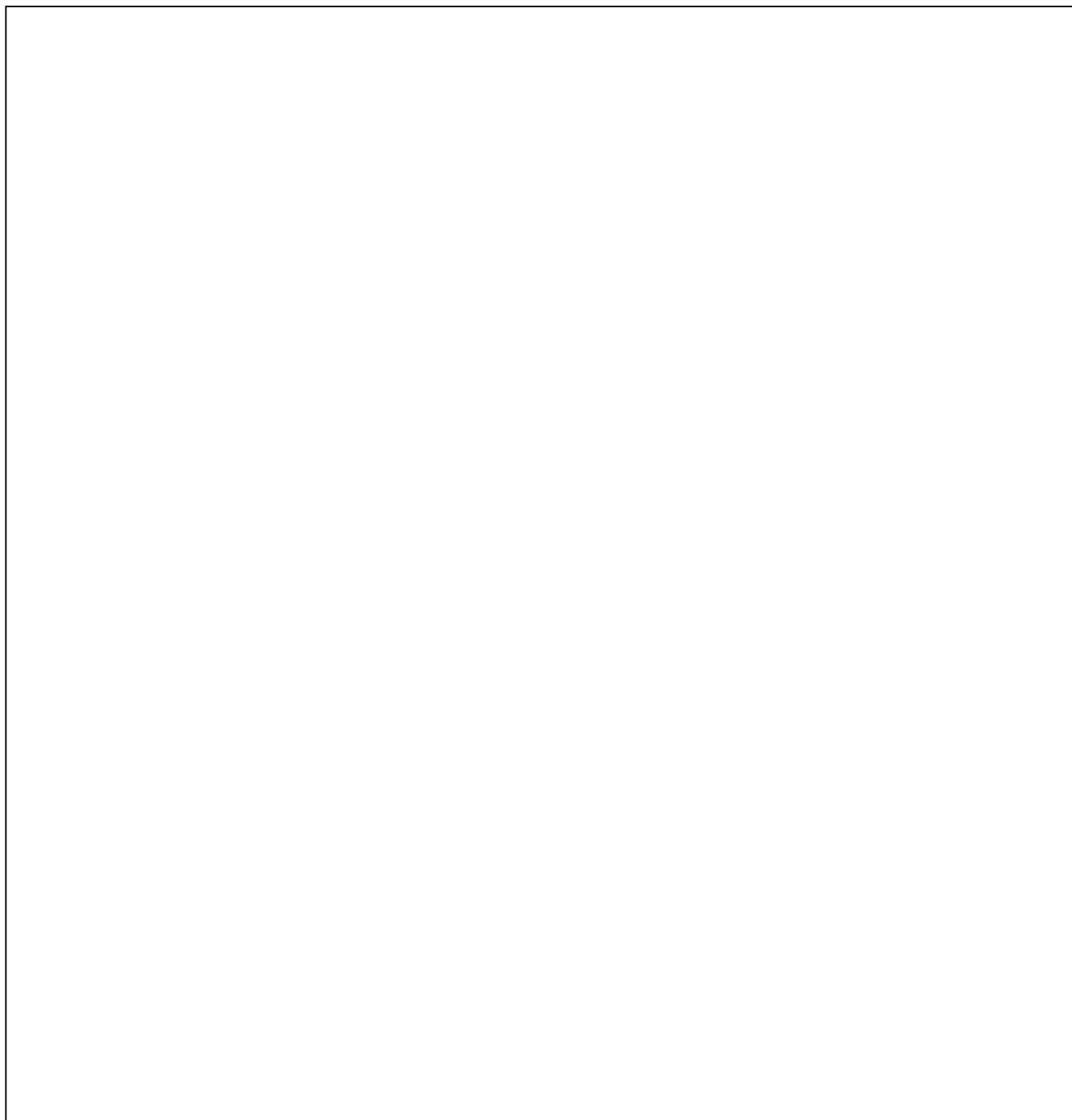

10 - SUBPLATES (See catalogue 51 000)	DSC3	DSC5
Type with rear ports	PMMD-AI3G	PMD4-AI4G
Type with side ports	PMMD-AL3G	PMD4-AL4G
Threading of ports P, T, A, B,	3/8" BSP	1/2" BSP

 DIPLOMATIC HYDRAULICS	DIPLOMATIC OLEODINAMICA SpA 20025 LEGNANO (MI) - P.le Bozzi, 1 / Via Edison Tel. 0331/472111 - Fax 0331/548328	
---	---	--