



DT03

POPPET TYPE SOLENOID OPERATED DIRECTIONAL CONTROL VALVE

SERIES 10

SUBPLATE MOUNTING
ISO 4401-03 (CETOP 03)

p max 250 bar
Q max 25 l/min

MOUNTING INTERFACE

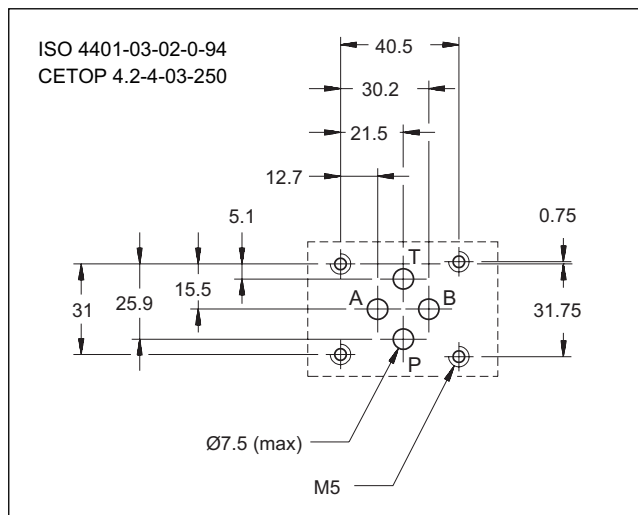

OPERATING PRINCIPLE

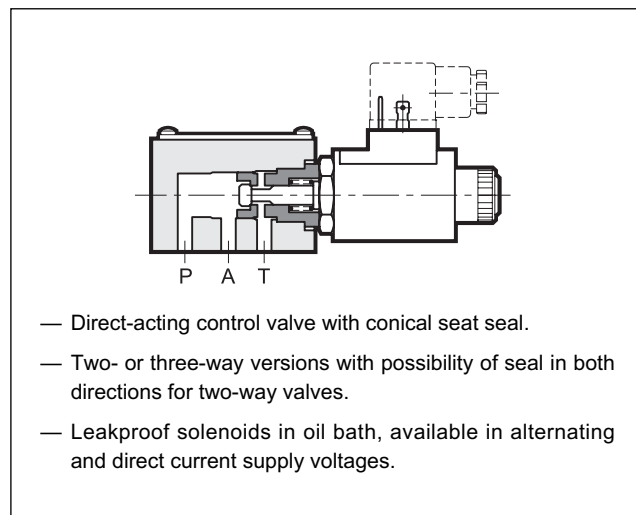

CONFIGURATIONS (see Hydraulic symbols table below)

- Configurations "A", "B", "C", "D": 3-way, 2-position solenoid valves.
- Configurations "E", "F", "G", "H": 2-way, 2-position solenoid valves.

PERFORMANCES (measured with mineral oil of viscosity 36 cSt at 50°C)

Maximum operating pressure	bar	250
Maximum flow rate	l/min	25
Ambient temperature range	°C	-20 / +50
Fluid temperature range	°C	-20 / +80
Fluid viscosity range	cSt	10 + 400
Fluid contamination degree	According to ISO 4406:1999 class 20/18/15	
Recommended viscosity	cSt	25
Mass	kg	1,3

HYDRAULIC SYMBOLS

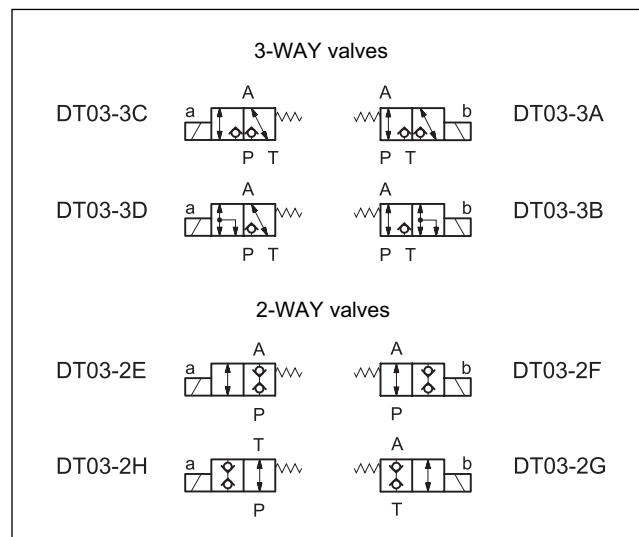



1 - IDENTIFICATION CODE

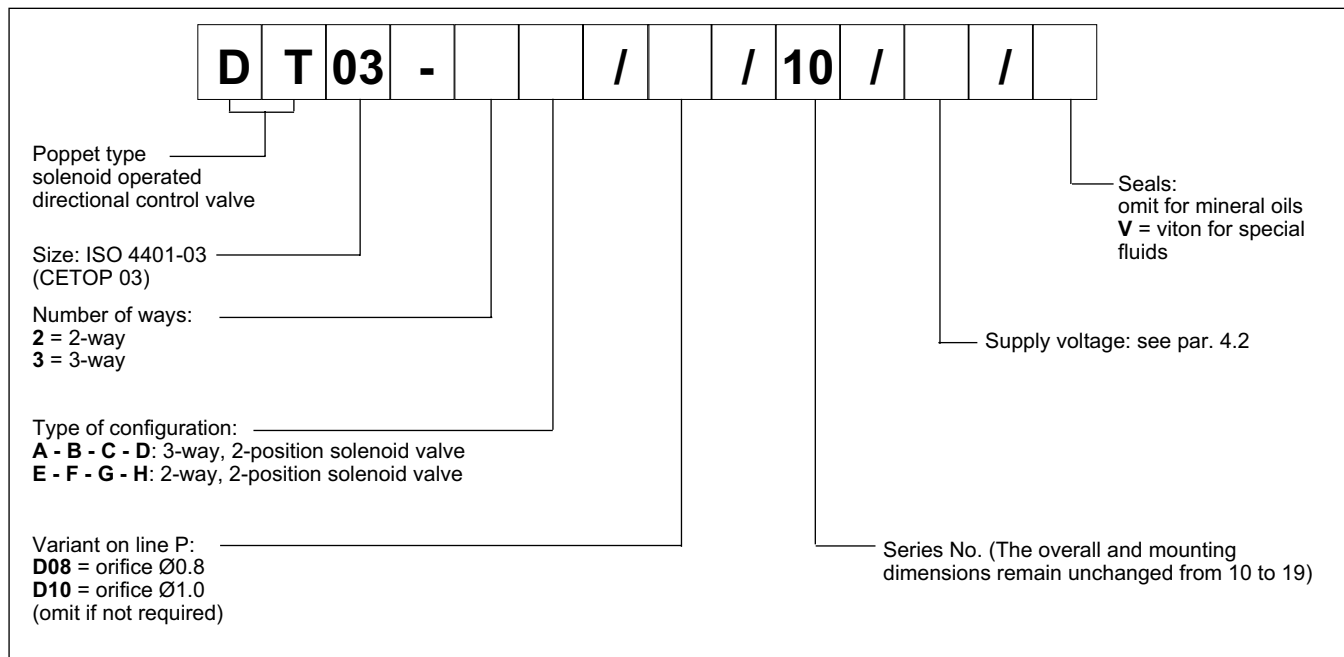

2 - CHARACTERISTIC CURVES (values obtained with viscosity 36 cSt at 50 °C)

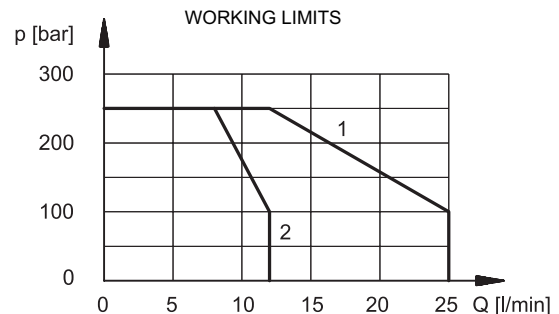
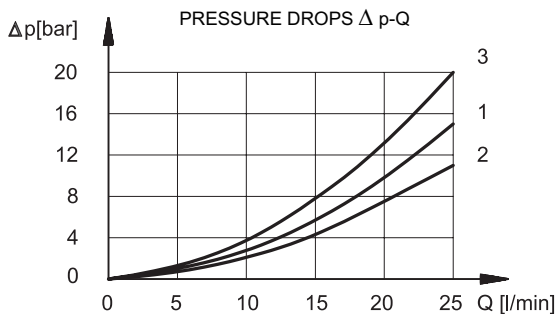

valve code	Curve on graph	
	De-energized solenoid	Energized solenoid
DT03-3A	1	3
DT03-3B	2	3
DT03-3C	1	3
DT03-3D	2	3
DT03-2E	-	3
DT03-2F	1	-
DT03-2G	-	3
DT03-2H	1	-

Valve	Curve on graph
DT03-3A	2
DT03-3B	1
DT03-3C	1
DT03-3D	1
DT03-2E	1
DT03-2F	2
DT03-2G	1
DT03-2H	1

3 - HYDRAULIC FLUIDS

Use mineral oil-based hydraulic fluids HL or HM type, according to ISO 6743-4. For these fluids, use NBR seals. For fluids HFDR type (phosphate esters) use FPM seals (code V). For the use of other kinds of fluid such as HFA, HFB, HFC, please consult our technical department. Using fluids at temperatures higher than 80 °C causes a faster degradation of the fluid and of the seals characteristics. The fluid must be preserved in its physical and chemical characteristics.



4 - ELECTRICAL FEATURES

4.1 Solenoids

These are essentially made up of two parts: tube and coil. The tube is threaded onto the valve body and includes the armature that moves immersed in oil, without wear. The inner part, in contact with the oil in the return line, ensures heat dissipation. The coil is fastened to the tube by a threaded nut, and can be turned 360° on its axis, compatible with space available. The interchangeability of coils of different voltages is allowed within the same type of supply current: alternating or direct (DC / RAC).

4.2 Available voltages

It is necessary to always use "D" type connectors (with rectifier incorporated) and RAC coils for alternating current supply. Rectified current supply takes place by using a bridge rectifier bridge, externally or fitted within the "D" type connectors, between the alternating current source (24V or 110V, /50 or /60 Hz) and the coil.

4.3 Current and power consumption

Voltage [V]	Frequency [Hz]	Current consumption (±5%) [A]	Power (±5%) [W]
12	DC	2,38	28,8
24	DC	1,19	
24	RAC	1,4	28,8
110	RAC	0,3	
220	RAC	0,15	

4.4 Switching times

The values indicated refer to a flow rate of Q = 10 l/min, p = 210 bar working with mineral oil at a temperature of 50°C, a viscosity of 36 cSt and supply voltage equal to 90% of the nominal voltage.

TIMES (±10%)	ENERGIZING	DE-ENERGIZING
	30 ms	50 ms

4.5 Electric connectors

The solenoid valves are never supplied with connector.

Connectors must be ordered separately.

For the identification of the connector type to be ordered, please see catalogue 49 000.

SUPPLY VOLTAGE FLUCTUATION	± 10% Vnom
DUTY CYCLE	100%
CLASS OF PROTECTION: Atmospheric agents Coil insulation Impregnation	IP 65 class H class F

DIRECT CURRENT COILS		
12V CC	24V CC	
RAC COILS		
24V RAC	110V RAC	220V RAC



5 - OVERALL AND MOUNTING DIMENSIONS

NOTE: The solenoid position here shown is for A-B-F-G versions. For the other versions the solenoid is on the opposite side.

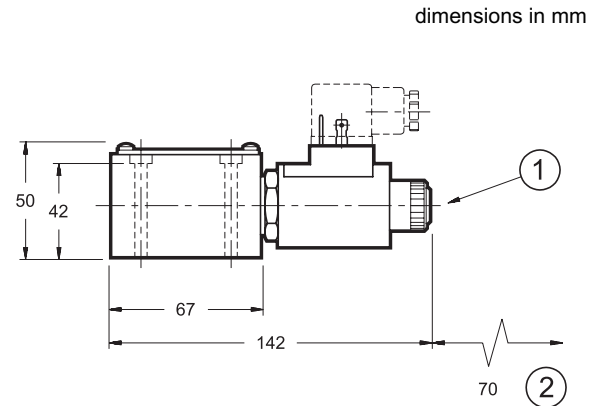
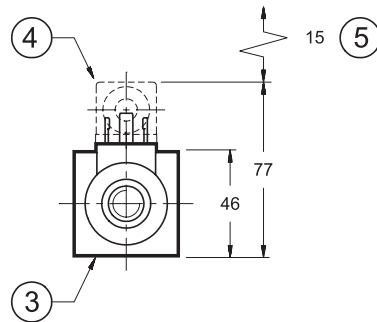

dimensions in mm

Fastening bolts:
4 bolts M5 x 50
Torque: 5 Nm

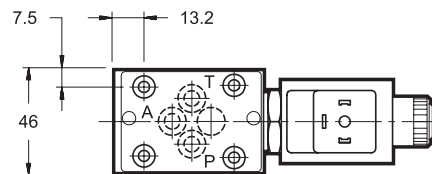

1	Manual override
2	Coil removal space
3	Mounting surface with sealing rings: 4 OR type 2037 (9.25X1.78) - 90 Shore
4	Electric connector to be ordered separately (see cat. 49 000)
5	Connector removal space

6 - APPLICATION EXAMPLES

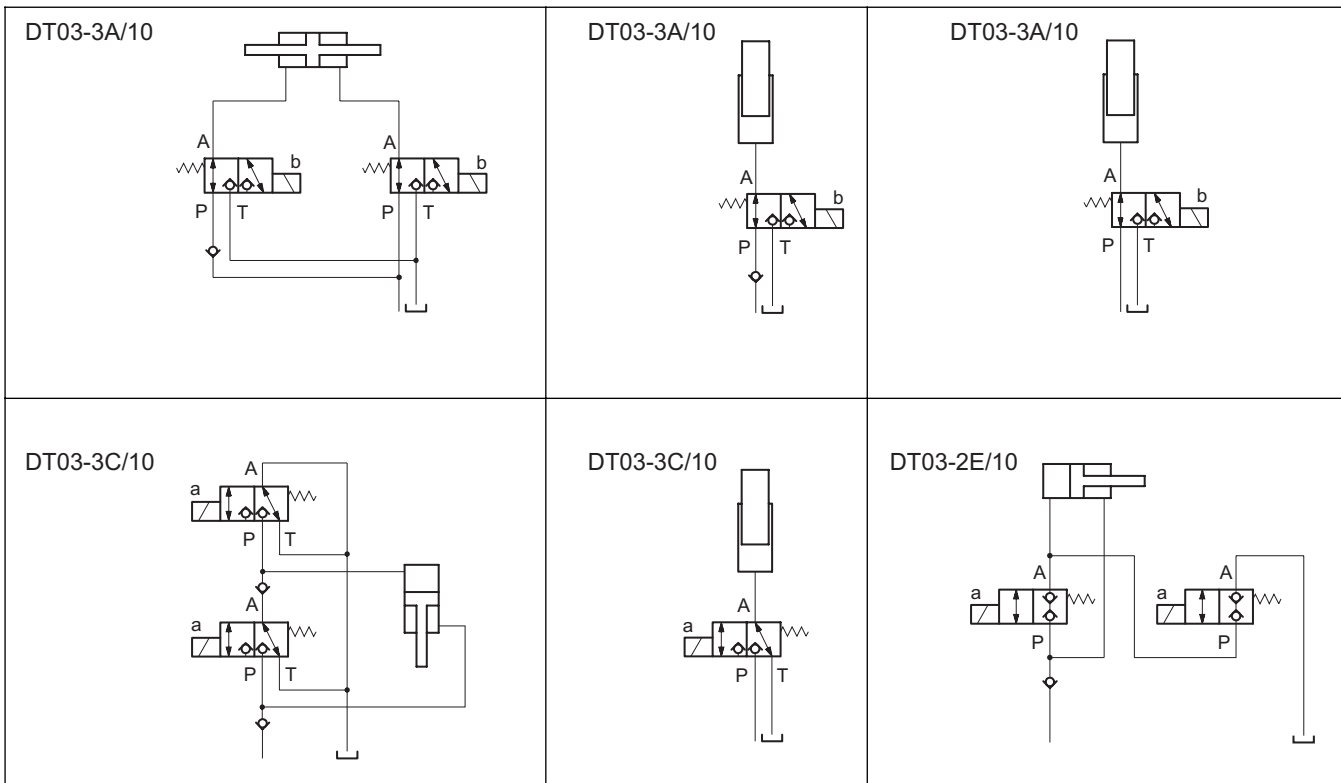

DIPLOMATIC OLEODINAMICA SpA
20025 LEGNANO (MI) - P.le Bozzi, 1 / Via Edison
Tel. 0331/472111-472236 - Fax 0331/548328