

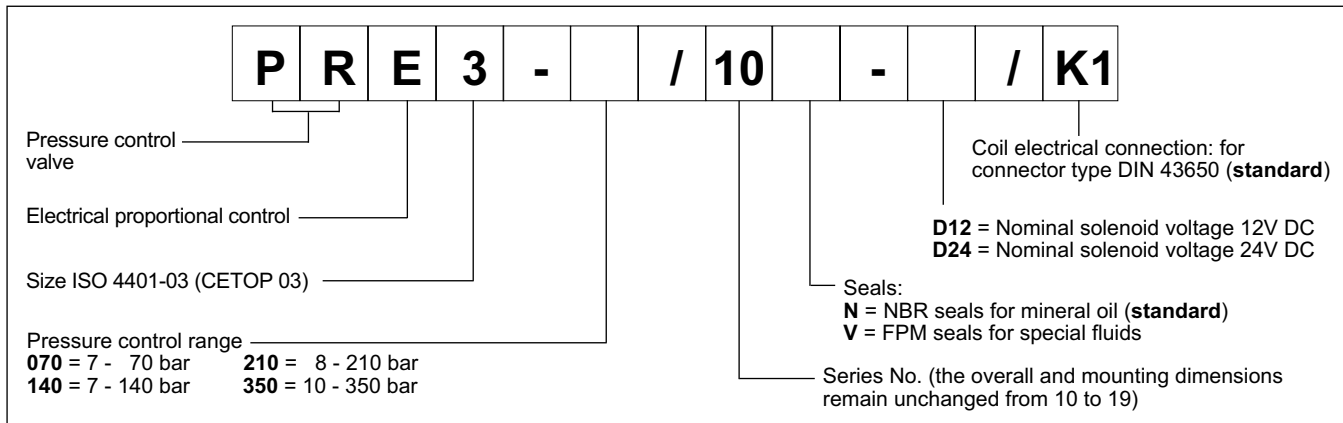

1 - IDENTIFICATION CODE



2 - CHARACTERISTIC CURVES (measured with viscosity of 36 cSt at 50°C)

Typical control curves according to the current supplied to the solenoid (D24 version with maximum current 860 mA) for pressure control ranges: 070, 140, 210, 350, measured with input flow rate Q=10 l/min.

The curves are obtained without any hysteresis and linearity compensation and they are measured without any backpressure in T. The full scale pressure is set in factory with a flow rate of 10 l/min. In case of higher flow rate, the full scale pressure will increase considerably (see diagram $p_{max} = f(Q)$)

PRESSURE CONTROL $p=f(I)$

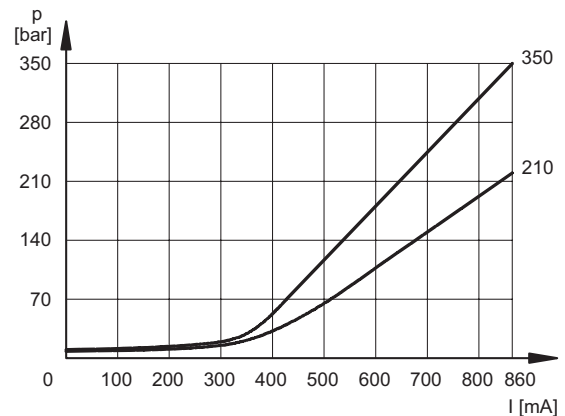
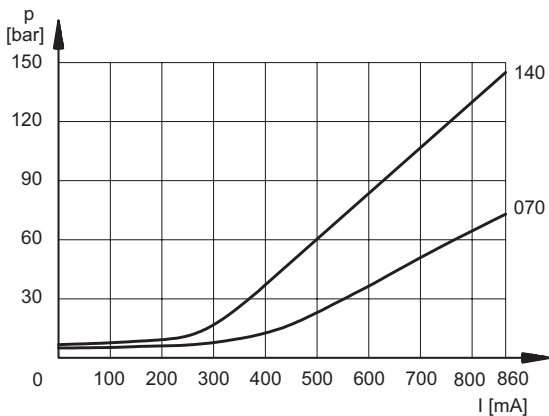

MINIMUM CONTROLLED PRESSURE $p_{min} = f(Q)$

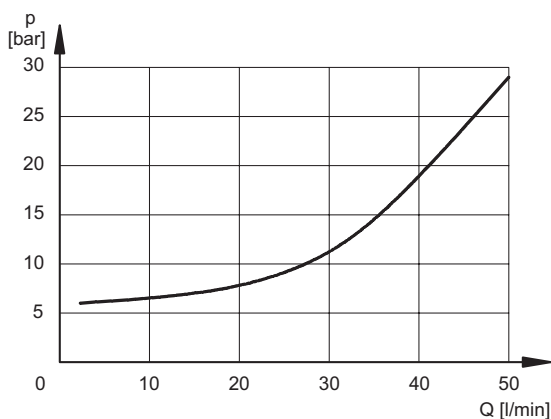

PRESSURE VARIATION $p_{max} = f(Q)$

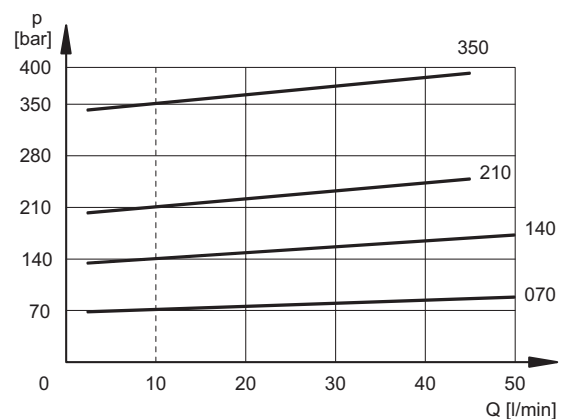

Q = 10 lt/min
factory setting



3 - HYDRAULIC FLUIDS

Use mineral oil-based hydraulic fluids HL or HM type, according to ISO 6743-4. For these fluids, use NBR seals (code N).
For fluids HFDR type (phosphate esters) use FPM seals (code V).
For the use of other fluid types such as HFA, HFB, HFC, please consult our technical department.

Using fluids at temperatures higher than 80 °C causes a faster degradation of the fluid and of the seals characteristics.
The fluid must be preserved in its physical and chemical characteristics.

4 - ELECTRICAL CHARACTERISTICS

Proportional solenoid

The proportional solenoid comprises two parts: tube and coil.

The tube, screwed to the valve body, contains the armature which is designed to maintain friction to a minimum thereby reducing hysteresis.

The coil is mounted on the tube secured by means of a lock nut and can be rotated through 360° depending on installation clearances.

NOMINAL VOLTAGE	V DC	12	24
RESISTANCE (at 20°C)	Ω	3.66	17.6
MAXIMUM CURRENT	A	1.88	0.86
DUTY CYCLE		100%	
ELECTROMAGNETIC COMPATIBILITY (EMC)		According to 89/336 CEE	
emissions	EN 50081-1		
immunity	EN 50082-2		
CLASS OF PROTECTION:		IP 65	
Atmospheric agents (CEI EN 60529)			

5 - STEP RESPONSE (obtained with mineral oil with viscosity of 36 cSt at 50°C and electronic control cards)

Step response is the time taken for the valve to reach 90% of the set pressure value following a step change of reference signal.

The table illustrates typical step response times measured with a valve of pressure range up to 140 bar and with input flow rate Q = 10 l/min.

REFERENCE SIGNAL STEP	0 → 100%	100 → 0%
Step response [ms]	80	40

6 - INSTALLATION

We recommend to install the PRE3 valve either in horizontal position, or vertical position with the solenoid downward. If the valve is installed in vertical position and with the solenoid upward, you must consider possible variations of the minimum controlled pressure, if compared to what is indicated in paragraph 2.

Ensure that there is no air in the hydraulic circuit. In particular applications, it can be necessary to vent the air entrapped in the solenoid tube, by using the apposite drain screw in the solenoid tube. Ensure that the solenoid tube is always filled with oil (see par. 7). At the end of the operation, make sure of having screwed correctly the drain screw.

Connect the valve T port directly to the tank. Add any backpressure value detected in the T line to the controlled pressure value. Maximum admissible backpressure in the T line, under operational conditions, is 2 bar.

Valves are fixed by means of screws or tie rods on a flat surface with planarity and roughness equal to or better than those indicated in the relative symbols. If minimum values are not observed, fluid can easily leak between the valve and support surface.

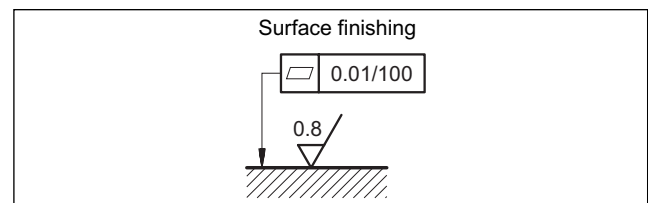



7 - OVERALL AND MOUNTING DIMENSIONS

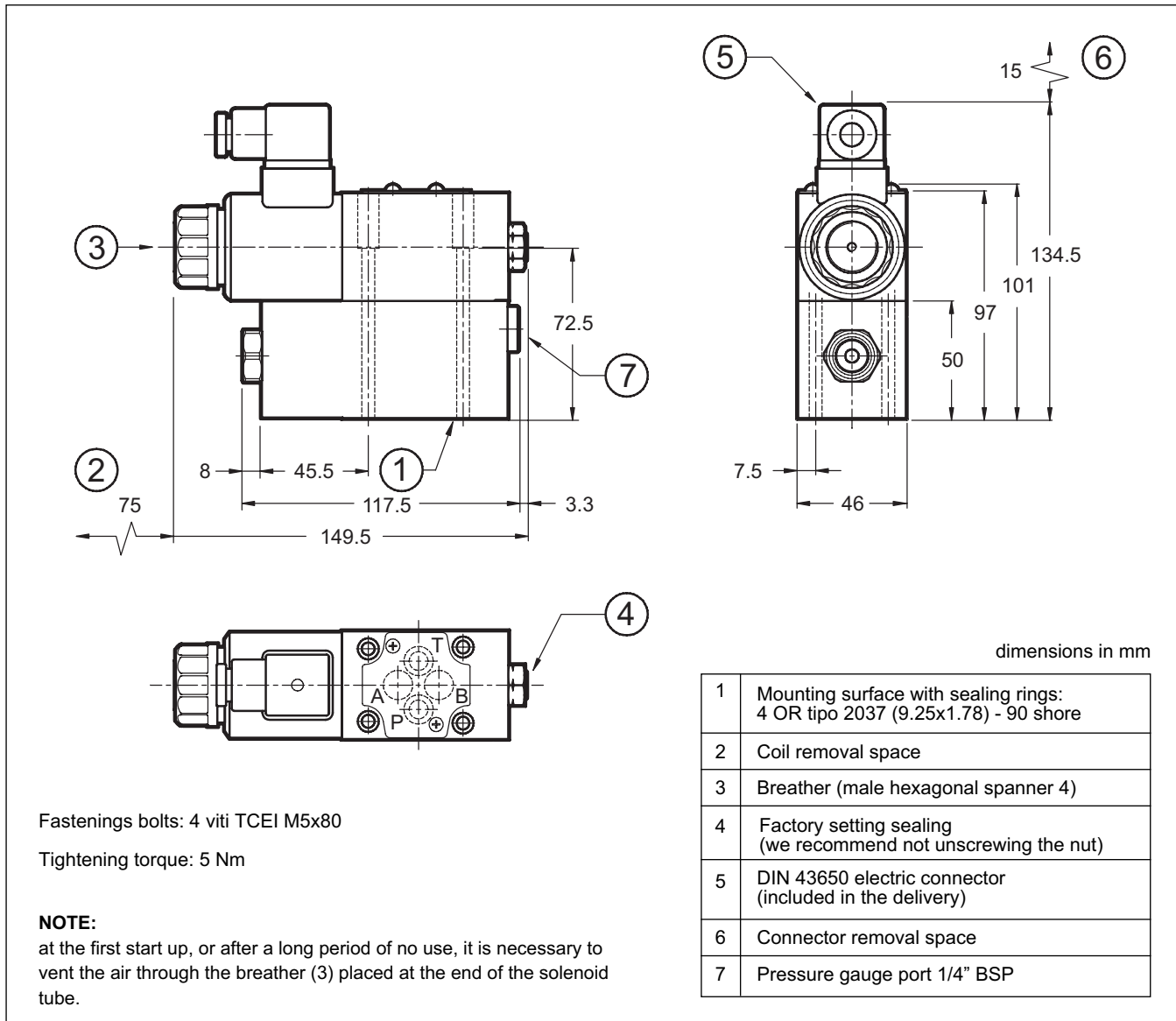

8 - ELECTRONIC CONTROL UNITS

EDC-112	for solenoid 24V DC	plug version	see cat.89 120
EDM-M112	for solenoid 24V DC	DIN EN 50022 rail mounting	see cat. 89 250
EDM-M142	for solenoid 12V DC		
UEIK-11	for solenoid 24V DC	Eurocard type	see cat. 89 300

9 - SUBPLATES (see catalogue 51 000)

PMMD-AI3G with ports on rear
PMMD-AL3G with side ports
Ports dimensions P, T, A and B: 3/8" BSP thread

	<p>DIPLOMATIC OLEODINAMICA SpA 20025 LEGNANO (MI) - P.le Bozzi, 1 / Via Edison Tel. 0331/47211 - Fax 0331/548328</p>
--	---