



**DIPLOMATIC  
HYDRAULICS**



# VPPM

## VARIABLE DISPLACEMENT AXIAL-PISTON PUMPS

### OPERATING PRINCIPLE

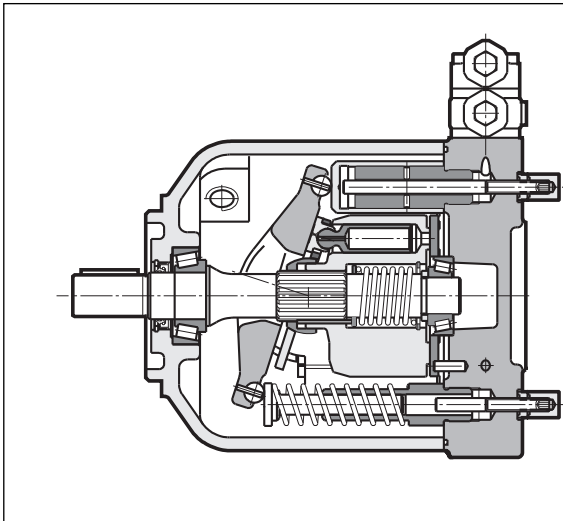

- The VPPM pumps are variable displacement axial-piston pumps with variable swash plate, suitable for applications with open circuits.
- They are available in three different frame sizes with maximum displacements up to 29, 46 and 73 cm<sup>3</sup>/rev.
- The pump flow rate is proportional to the rotation speed and to the angle of the swash plate, which can be continuously modulated. The maximum and minimum angle can be limited mechanically via suitable regulating screws.
- The pumps feature medium-high working pressures (280 bar constant and 350 bar peak). Thanks to some particular design features, these pumps are able to bear high axial and radial loads on the shaft.
- They are usually supplied with a ISO 3019/2 mounting flange, with the exception of the rear and intermediate pumps, which are only available with a SAE J744 2-holes flange and a SAE J744 splined shaft (see paragraph 15).
- They are available with seven different types of regulating control, each according to the application needs (see paragraphs 7 ÷ 13).

### TECHNICAL SPECIFICATIONS

PUMP SIZE		029	046	073
Maximum displacement	cm <sup>3</sup> /rev	29	46	73
Operating flow rate and pressures		see table 3 - Performances		
Rotation speed		see table 3 - Performances		
Rotation direction		clockwise or anticlockwise (looking at the drive shaft)		
Loads on the shaft: axial load radial load	N	1000 2500	1500 3800	2500 6100
Maximum shaft torque		see table 3 - Performances		
Hydraulic connection		SAE flange fittings (see paragraph 20)		
Type of mounting (single pump)		ISO 3019/2 flange		
Oil volume in the pump body	dm <sup>3</sup>	0,7	0,9	1,5
Mass (empty single pump)	kg	18	24	33

Ambient temperature range	°C	-15 / +70
Fluid temperature range	°C	-25 / +90
Fluid viscosity range		see paragraph 2.2
Fluid contamination degree		see paragraph 2.3
Recommended viscosity	cSt	15 ÷ 35

### HYDRAULIC SYMBOL

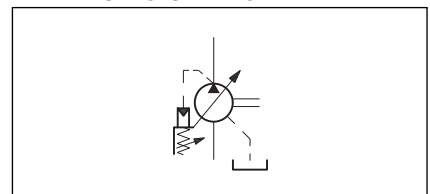



## 1 - IDENTIFICATION CODES

### 1.1 - Identification code for single and front pumps with a through output shaft

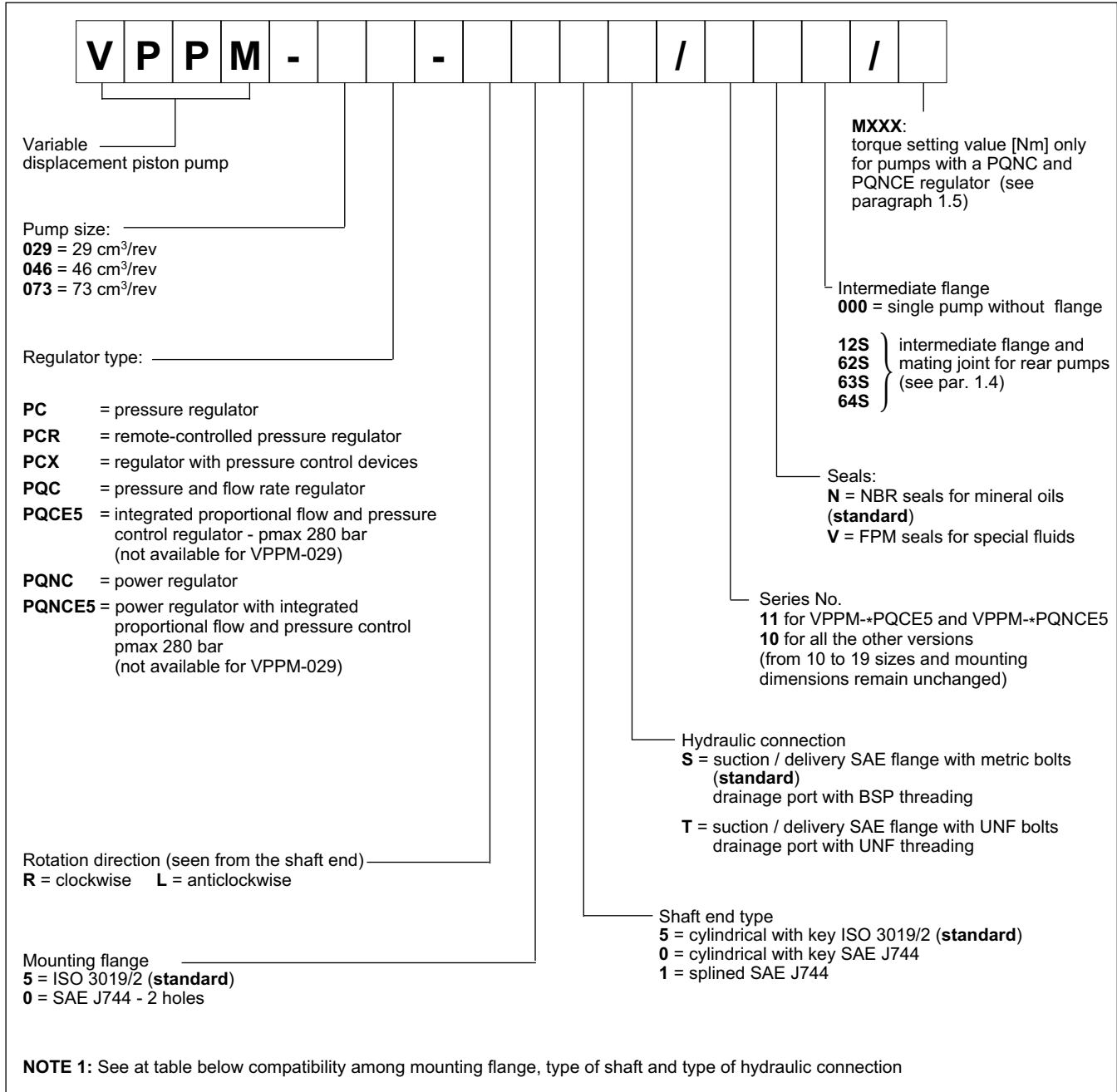

### Compatibility among mounting flange, type of shaft and type of hydraulic connection

FLANGE CODE	SHAFT CODE			HYDRAULIC CONNECTION CODE	
	5	0	1	S	T
5	yes	no	no	yes	no
0	no	yes	yes	yes	yes

VPPM pumps are supplied as standard with mechanical minimum and maximum displacements limit controls. These devices are not available for front and intermediate pumps with a through output shaft.



## 1.2 - Identification code for intermediate pumps with a through output shaft and rear pumps

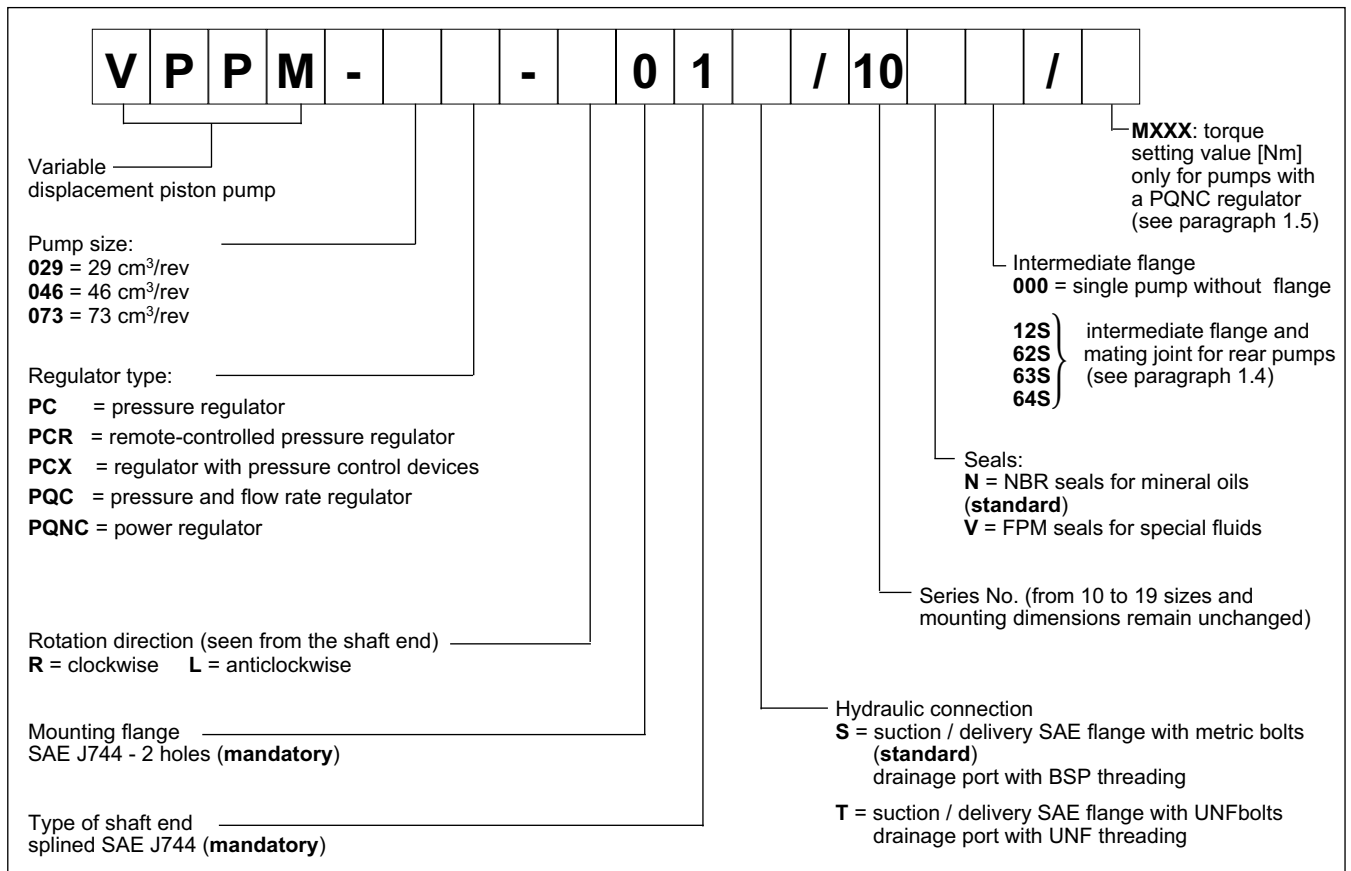

## 1.3 - Identification code for double pumps

identification code + identification code  
 1st pump                      2nd pump

## 1.4 - Identification code for intermediate flange and mating joint for pumps with a through output shaft

According to the pump to be coupled, it is necessary to define, into the identification code, the flange and mating joint type to be applied to the pump with a through output shaft.

The following table states the flange and joint reference code according to the different pump types to be pulled, stating also the possible coupling combinations.

Identification code for intermediate flange + mating joint	intermediate flange	mating joint	pump to be mated	possible combinations for VPPM pump with a through output shaft		
				29	46	73
<b>12S</b>	SAE J744 2 holes - type "A"	SAE J744 splined 16/32 D.P. - 9T	GP 2 external gear	yes	yes	yes
<b>62S</b>	SAE J744 2 holes - type "B"	SAE J744 splined 16/32 D.P. - 13T	GP 3 external gear	no	yes	yes
			VPPM-029	yes		
<b>63S</b>	SAE J744 2 holes - type "B"	SAE J744 splined 16/32 D.P. - 15T	VPPM-046	no	yes	yes
<b>64S</b>	SAE J744 2 holes - type "C"	SAE J744 splined 12/24 D.P. - 14T	VPPM-073	no	no	yes

**NOTE:** For the flange type and dimensions see paragraph 20.



## 1.5 - Standardized torque values for PQNC and PQNCE regulators

ELECTRICAL MOTOR 4 POLES		VPPM-029		VPPM-046		VPPM-073	
Power [kW]	N [rpm]	torque [Nm]	p regulation start. [bar]	torque [Nm]	p regulation start. [bar]	torque [Nm]	p regulation start. [bar]
4	1425	26 (#)	46	-	-	-	-
5,5	1440	36 (#)	62	36 (#)	41	-	-
7,5	1450	50	84	50 (#)	56	-	-
9,2	1460	60	103	60 (#)	68	60 (#)	44
11	1455	72	124	72	82	72 (#)	53
15	1460	98	168	98	111	98 (#)	72
18,5	1460	-	-	122	137	122	89
22	1465	-	-	144	163	144	105
30	1470	-	-	-	-	196	143
37	1475	-	-	-	-	240	175

(#) With this adjustment value the pump is in venting position with a pressure less than 280 bar.

## 1.6 - Identification examples

- a) 29 cm<sup>3</sup>/rev single pump with pressure regulator - ISO mounting flange and shaft (standard)  
**VPPM-029PC-R55S/10N000**
- b) 46 cm<sup>3</sup>/rev single pump with pressure regulator with remote control - SAE mounting flange and SAE splined shaft  
**VPPM-046PCR-R01S/10N000**
- c) 73 cm<sup>3</sup>/rev single pump with pressure control devices - ISO mounting flange and shaft (standard)  
**VPPM-073PCX-R55S/10N000**
- d) 46 cm<sup>3</sup>/rev single pump with integrated proportional flow and pressure control regulator - pressure regulation up to 280 bar  
**VPPM-046PQCE5-R55S/11N000**
- e) 46 cm<sup>3</sup>/rev single pump with power regulator set at 18,5 kW at 1460 rpm (torque = 122 Nm)  
**VPPM-046PQNC-R55S/10N000/M122**
- f) 73 cm<sup>3</sup>/rev single pump with power regulator with integrated proportional flow and pressure control - power regulator set at 98 Nm - pressure regulation up to 280 bar  
**VPPM-073PQNCE5-R55S/11N000/M098**
- g) 73 cm<sup>3</sup>/rev front pump with pressure regulator, ready to mate to a VPPM-029 pump  
**VPPM-073PC-R55S/10N62S**
- h) double pump made of:
  - 46 cm<sup>3</sup>/rev front pump with pressure and flow rate regulator
  - 29 cm<sup>3</sup>/rev rear pump with pressure regulator**VPPM-046PQC-R55S/10N62S + VPPM-029PC-R01S/N000**
- i) triple pump made of:
  - 73 cm<sup>3</sup>/rev front pump with flow rate and pressure regulator
  - 46 cm<sup>3</sup>/rev intermediate pump with pressure regulator
  - 14 cm<sup>3</sup>/rev rear gear pump group 2**VPPM-073PQC-R55S/10N63S + VPPM-046PC-R01S/10N12S + GP2-0140R01F/10N**



## 2 - HYDRAULIC FLUID

### 2.1 - Fluid type

Use mineral oil based hydraulic fluids with anti-foam and antioxidant additives according to the DIN 51524 norm.  
For use with other types of fluid, keep in mind the limitations shown in the following table or consult our technical department for authorization of use.

FLUID TYPE	NOTES
HFC (water glycol solution with proportion of water $\leq 40\%$ )	<ul style="list-style-type: none"><li>- The performance ratings shown in the table in paragraph 3 must be reduced as follows: maximum continuous pressure: 200 bar max. rotation speed: VPPM-029 = 2100 rpm VPPM-046 = 2000 rpm VPPM-073 = 1700 rpm</li><li>- The suction pressure must be lower than 0,8 absolute bars (-0,2 relative bars)</li><li>- The fluid maximum temperature must be lower than 50°C.</li></ul>
HFD (phosphate esters)	Such fluids do not require any particular performance limitation. It is suggested to operate with continuous duty pressures not higher than 240 bars.

### 2.2 - Fluid viscosity

The operating fluid viscosity must be within the following range:

minimum viscosity	10 cSt	referred to a maximum temperature of 90 °C for the drainage fluid
optimum viscosity	15+ 35 cSt	referred to the operating temperature of the fluid in the tank
maximum viscosity	1000 cSt	limited only to the cold start-up of the pump, which has to be carried out with the plant at minimum pressure.

When selecting the fluid type, be sure that the true viscosity is within the range specified above at the operating temperature.

### 2.3 - Degree of fluid contamination

The maximum degree of fluid contamination must be according to ISO 4406:1999 class 20/18/15; therefore the use of a delivery or return filter with  $\beta_{20} \geq 75$  is suggested.

A degree of maximum fluid contamination according to ISO 4406:1999 class 18/16/13 is recommended for optimum endurance of the pump. Hence, the use of a filter with  $\beta_{10} \geq 100$  is recommended.

In the event that the filter is installed on the suction line, be sure that the pressure at the pump inlet is not lower than the values specified in the table of paragraph 3.

The suction filter must be equipped with a by-pass valve and, if possible, with a clogging indicator and should be oversized to avoid cavitation problems.



### 3 - PERFORMANCES (measured with mineral oil with viscosity of 36 cSt at 50°C)

PUMP SIZE		029	046	073
Maximum displacement	cm <sup>3</sup> /rev.	29	46	73
Maximum flow rate: - at 1500 rpm - at max rotation speed	l/min	43,5 87	69 119,6	109,5 160,5
Input pressure: - min - max	bar		-0,2 24	
Max. delivery pressure: - continuous - intermittent (NOTE1) - peak	bar		280 315 350	
Max pressure on drainage port	bar		0,5	
maximum power ( $\Delta p = 280$ bar): - at 1500 rpm - at max rotation speed	kW	20,3 40,6	32,2 55,8	51,1 74,9
Max absorbed torque: - $\Delta p = 100$ bar - $\Delta p = 280$ bar	Nm	46,2 129,3	73,2 205	116,2 325,3
Moment of inertia on the shaft	kgm <sup>2</sup>	0,0020	0,0030	0,0080
Maximum rotation speed at maximum displacement (NOTE 2)	rpm	3000	2600	2200

The pressure values stated in the table are to be understood as relative ones.

**NOTE 1:** Allowed intermittent duty pressures with a duration equal to 6 seconds per minute.

**NOTE 2:** Values referring to a zero bar pressure (relative) on the suction port.



## 4 - VPPM-029 PUMP CHARACTERISTIC CURVES (values obtained with mineral oil with viscosity of 36 cSt at 50°C)

The diagram curves were measured with a pump rotation speed of 1500 rpm.

### FLOW RATE/PRESSURE CURVES

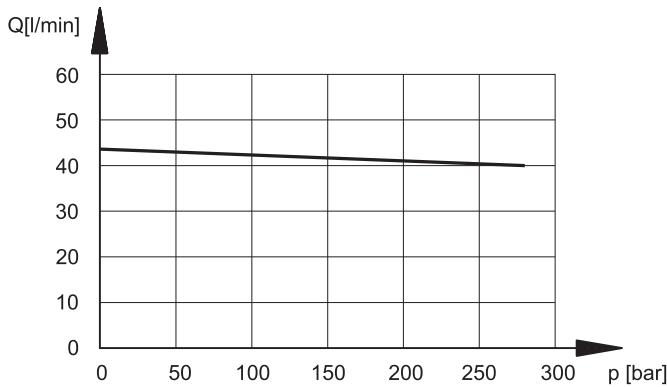

### VOLUMETRIC AND TOTAL EFFICIENCY

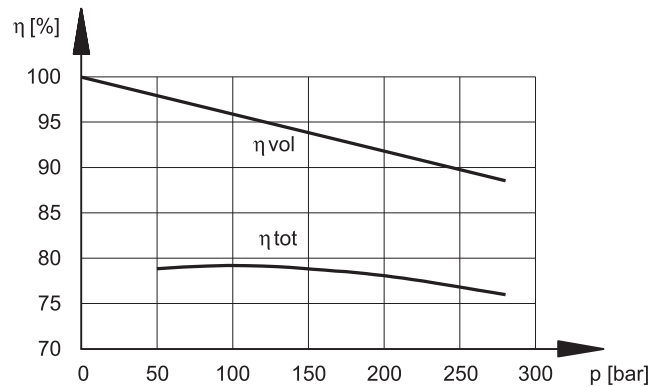

### ABSORBED POWER

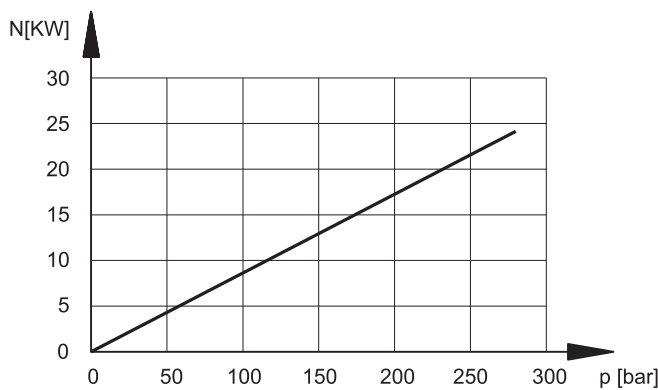

### NOISE LEVEL

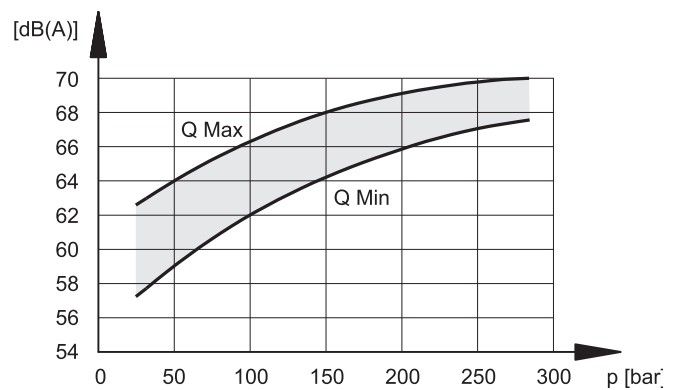

The noise pressure levels were measured in a semi-anechoic room, at a distance of 1 m from the pump and with a tolerance of  $\pm 2$  dB(A).

The values shown must be reduced by 5 dB(A) if they are to be considered in a completely anechoic room.



## 5 - VPPM-046 PUMP CHARACTERISTIC CURVES (values obtained with mineral oil with viscosity of 36 cSt at 50°C)

The diagram curves were measured with a pump rotation speed of 1500 rpm.

### FLOW RATE/PRESSURE CURVES

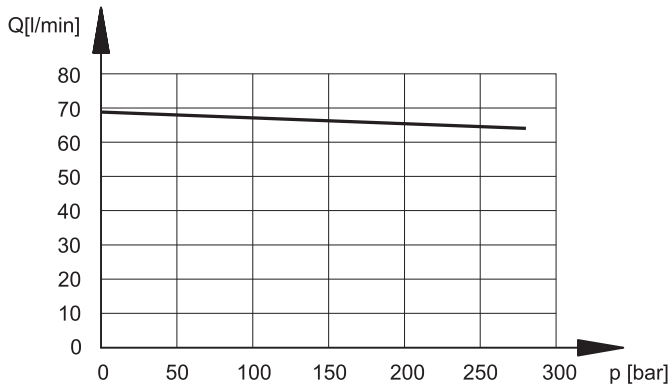

### VOLUMETRIC AND TOTAL EFFICIENCY

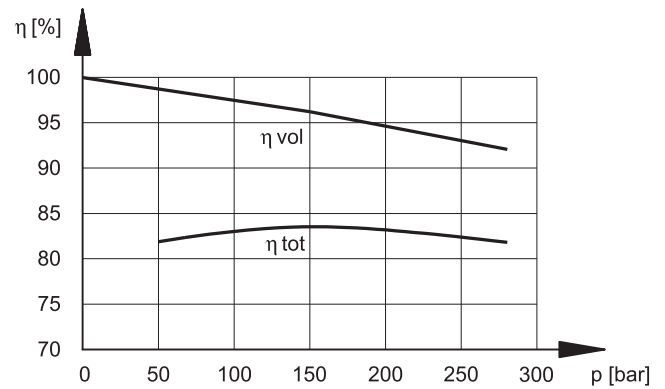

### ABSORBED POWER

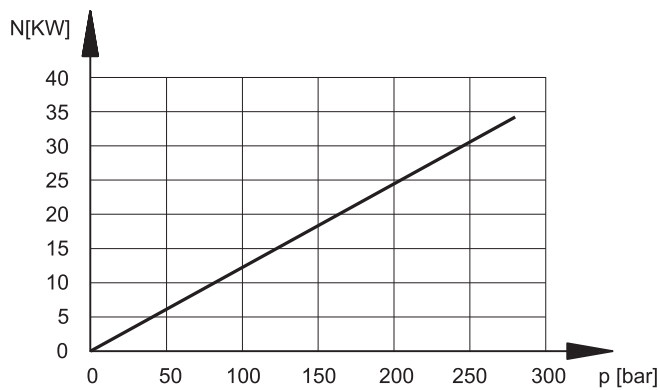

### NOISE LEVEL

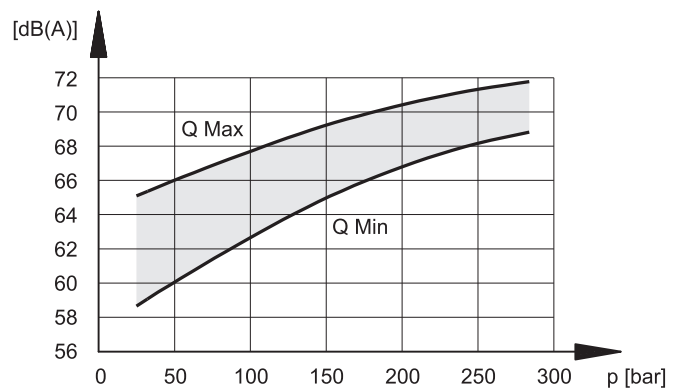

The noise pressure levels were measured in a semi-anecoic room, at a distance of 1 m from the pump and with a tolerance of  $\pm 2$  dB(A). The values shown must be reduced by 5 dB(A) if they are to be considered in a completely anecoic room.





## 6 - VPPM-073 PUMP CHARACTERISTIC CURVES (values obtained with mineral oil with a viscosity of 36 cSt at 50°C)

The diagram curves were measured with a pump rotation speed of 1500 rpm.

### FLOW RATE/PRESSURE CURVES

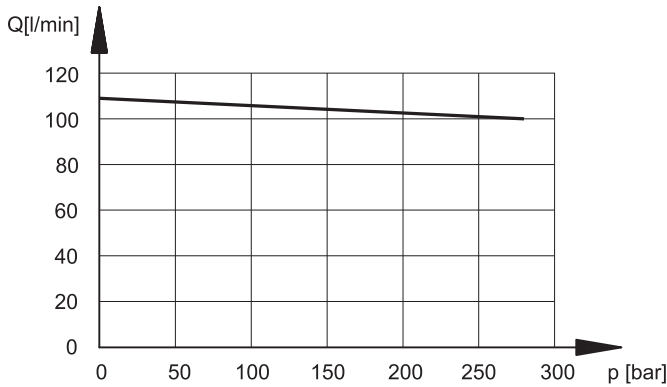

### VOLUMETRIC AND TOTAL EFFICIENCY

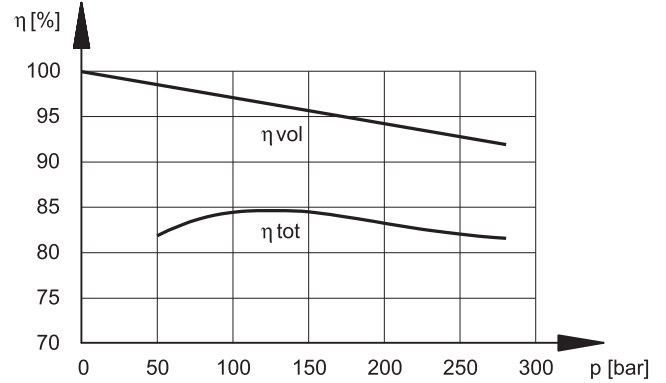

### ABSORBED POWER

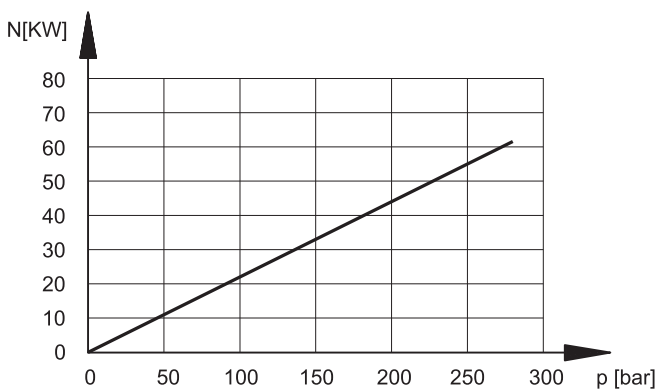

### NOISE LEVEL

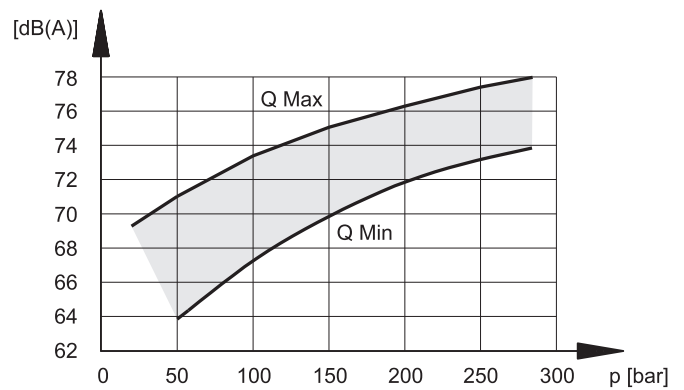

The noise pressure levels were measured in a semi-anechoic room, at a distance of 1 m from the pump and with a tolerance of  $\pm 2$  dB(A).

The values shown must be reduced by 5 dB(A) if they are to be considered in a completely anechoic room.



## 7 - PRESSURE REGULATOR: PC

### FUNCTIONAL DIAGRAM

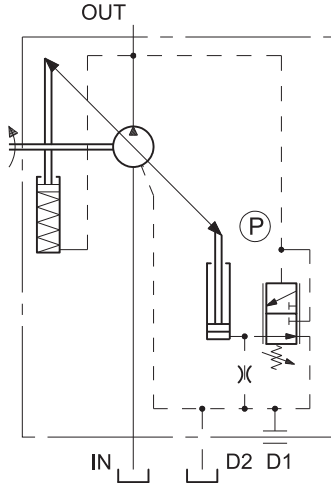

The PC pressure regulator keeps the pressure at a constant set level in the circuit, thus adjusting automatically the pump flow rate according to the real need of the system.

The desired pressure can be set by manually adjusting the (P) regulation valve.

### FEATURES OF THE PC REGULATOR:

- pressure regulating range (P) = 20 ÷ 350 bars
- default setting (P) = 280 bars

### 7.1 - Characteristic curves of the PC regulator (values obtained with mineral oil with a viscosity of 36 cSt at 50°C)

The diagram curves were measured with a pump rotation speed of 1500 rpm and an oil temperature of 50°C.

#### FLOW RATE/PRESSURE FEATURE

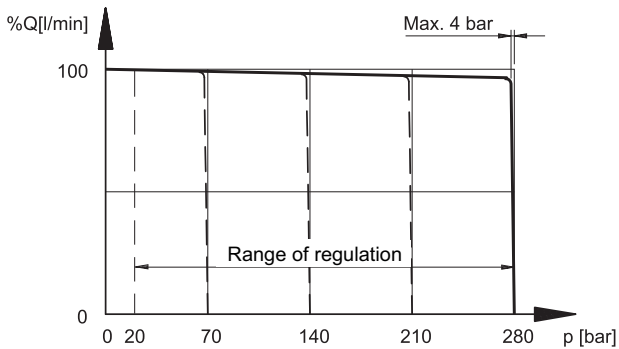

#### RESPONSE TIMES AND PEAK PRESSURE

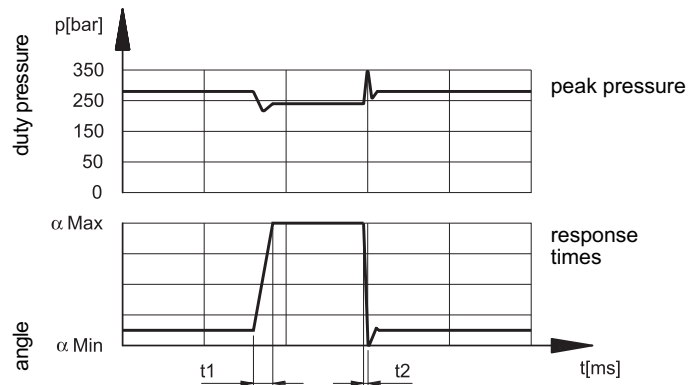

t1 = response time for a change from a min. to a max. displacement.

t2 = response time for a change from a max. to a min. displacement.

### PC pressure regulator set at 280 bars

pump size	t1 [ms]	t2 [ms]
<b>029</b>	30	20
<b>046</b>	45	25
<b>073</b>	50	30

The values stated in the table are obtained from the opening until the instant the delivery level is achieved, by using a maximum pressure valve set at 350 bars for a load simulation, placed at a distance of 1 m from the pump delivery port.



## 8 - REMOTE-CONTROLLED PRESSURE REGULATOR: PCR

### FUNCTIONAL DIAGRAM

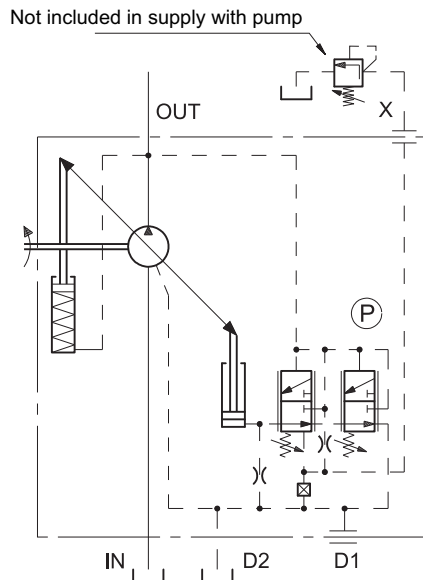

The PCR regulator, apart from limiting the line maximum pressure (P valve), allows a remote-control of the device via a remote control connected to the X port (typical application for submerged pumps). In case a pressure regulating valve is used for the remote-control, it is suggested to use a direct operated valve with a size suitable to 1,5 l/min pilot flow rate.

N.B. The maximum length of the connection between the valve and the pump X port must not be longer than 2 m.

### PCR FEATURES:

- pressure regulating range (P) = 20 ÷ 350 bars
- default setting (P) = 280 bars
- remote-regulated pressure range = 14 ÷ 315 bars
- flow rate available on the X port for the remote-control = about 1,5 l/min

### 8.1- Characteristic curves of the PCR regulator (values obtained with mineral oil with a viscosity of 36 cSt at 50°C)

The diagram curves were measured with a pump rotation speed of 1500 rpm and an oil temperature of 50°C.

### FLOW RATE / PRESSURE FEATURE

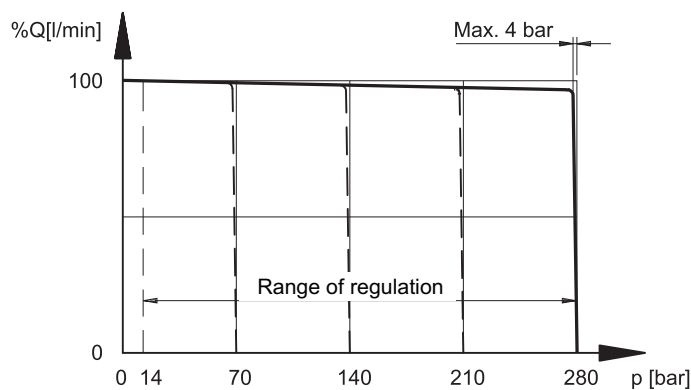

## 9 - REGULATOR WITH PRESSURE CONTROL DEVICES: PCX

### 9.1 - Electrical unloading

#### FUNCTIONAL DIAGRAM

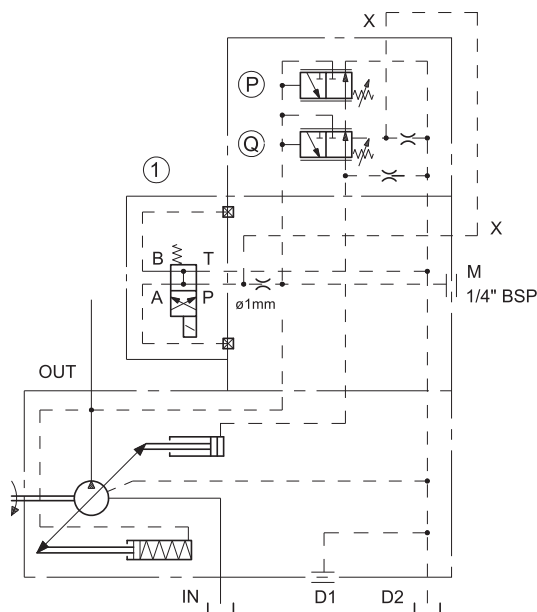

The PCX regulator, mated to a suitable two-position solenoid valve, allows the electrical switching of the pump displacement in null condition and with minimum delivery pressure.

This function is useful for the pump unloading at the start-up or to operate at minimum pressure in the system during the machine cycle pause, with considerable energy saving.

The pressure switching is made by means of a solenoid valve (to be ordered separately) installed on the pump regulator directly.

#### PCX FEATURES (electrical unloading):

- solenoid switching valve (1) = DS3-SA2 (to be ordered separately see cat. 41 150)
- solenoid valve OFF = pump at null displacement and delivery pressure = 20 bar
- solenoid valve ON = maximum displacement and delivery pressure set on regulator (P).
- pressure regulating range (P) = 20 ÷ 350 bar
- default setting (P) = 280 bar

### 9.2 - Two pressure settings + unloading

#### FUNCTIONAL DIAGRAM

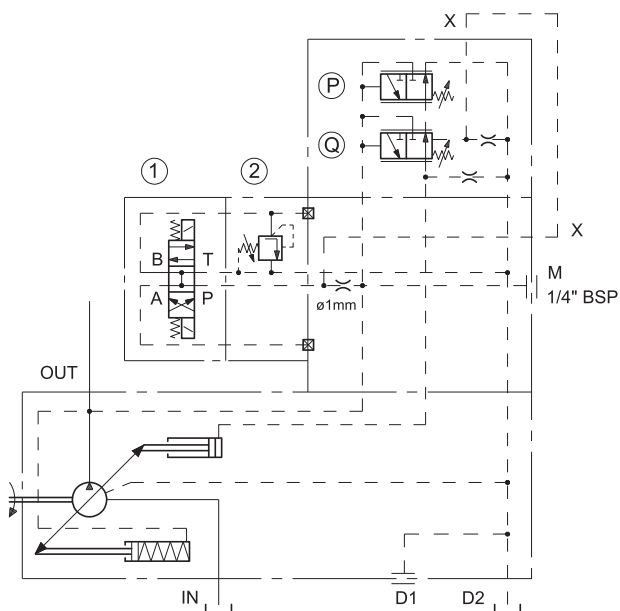

This type of regulator allows to select, by means of a three-position solenoid valve, two different working pressures; it allows also the pump unloading.

The solenoid valve (1) and the relief valve (2) for the intermediate pressure setting are directly installed on the pump regulator and they are to be ordered separately.

#### PCX FEATURES (two pressure settings + unloading):

- solenoid switching valve (1) = DS3-S2 (to be ordered separately see catalogue 41 150)
- solenoid valve OFF = pump unloading - delivery pressure = 20 bar
- solenoid side "a" ON = maximum displacement and delivery pressure set on relief valve (2) (intermediate value)
- solenoid side "b" ON = maximum displacement and delivery pressure set on regulator (P) (maximum value)
- pressure relief valve (2) = MCD\*-SBT (to be ordered separately - see cat. 61 200)
- pressure regulating range (2) = MCD3-SBT 20 ÷ 100 bar  
MCD5-SBT 20 ÷ 250 bar
- pressure regulating range (P) = 20 ÷ 350 bar
- default setting (P) = 280 bar

**NOTE:** For PCX regulators characteristic curves (with two pressure settings + unloading functions), see PC regulator diagrams at paragraph 7.1.



## 9.3 - Pressure regulation with electric proportional control

### FUNCTIONAL DIAGRAM

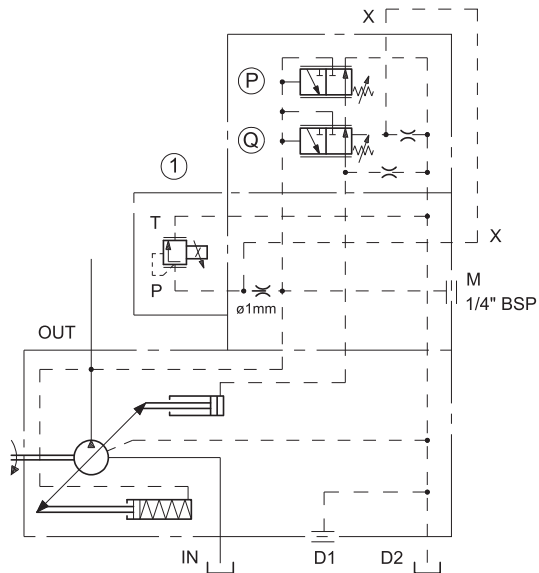

The PCX regulator mated with a proportional pressure relief valve, allows a continuous control and modulation of the system pressure.

The proportional pressure relief valve (to be ordered separately) is installed on the pump regulator directly.

### PCX FEATURES (proportional pressure regulation):

- pressure regulating range (P) = 20 ÷ 350 bar
- default setting (P) = 280 bar
- proportional pressure relief valve (1) = PRED3 (to be ordered separately with its relative electronic control unit - see catalogue 81 210)
- proportional pressure regulating range:
 

PRED3-070	20 ÷ 100 bar
PRED3-210	20 ÷ 240 bar
- Hysteresis = < 5% of p nom
- Repeatability = < ± 1,5% of p nom

### 9.3.1 - Characteristic curves (values obtained with mineral oil with a viscosity of 36 cSt at 50°C)

The diagram curves were measured with a pump rotation speed of 1500 rpm and an oil temperature of 50°C.

#### FLOW RATE / PRESSURE FEATURE

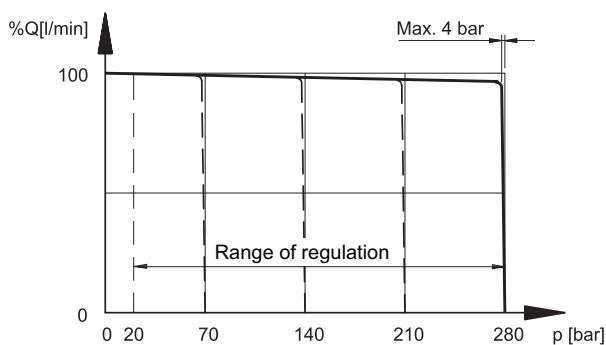

#### CURRENT / PRESSURE FEATURE

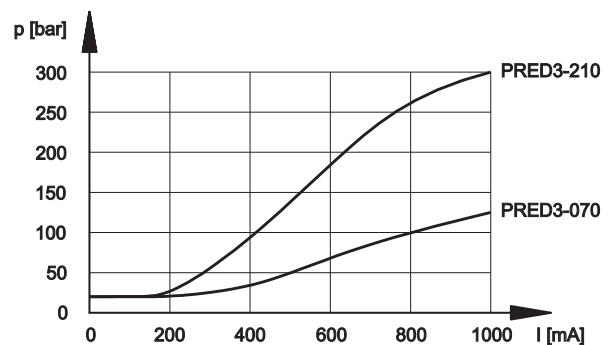

#### RESPONSE TIME

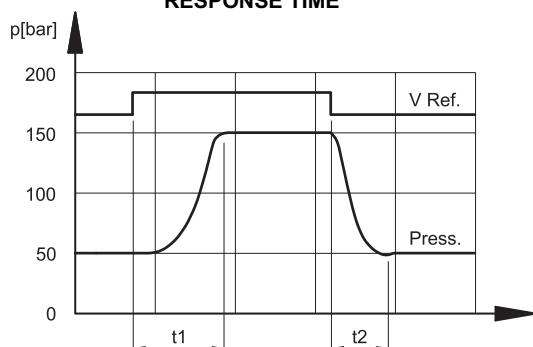

The response times are obtained with a VPPM-046 pump, by changing the reference signal (V Ref) on the proportional valve in order to have a line pressure variation from 50 to 150 bar and vice versa, with an oil volume of 5 lt.

- t1 = 80 ms (response time for an increasing pressure change)
- t2 = 60 ms (response time for a decreasing pressure change)



## 10 - FLOW RATE AND PRESSURE REGULATOR: PQC

### FUNCTIONAL DIAGRAM

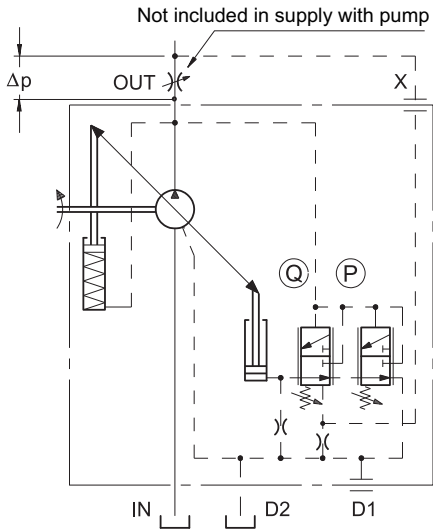

This regulator, apart from regulating the pressure (as for the PC model), allows the pump flow rate to be regulated according to the  $\Delta p$  pressure drop measured on either side of a throttle valve installed on the user line. The connection pipe between the X port and the flow line downstream the restrictor (or valve) must always be made (customer charge).

### PQC FEATURES:

- pressure regulating range (P) = 20 + 350
- default setting (P) = 280 bar
- differential pressure regulating range (Q) = 10 + 30 bars
- default setting = 14 bar
- Min. discharge head =  $18 \pm 2$  bar  
(with a zero flow rate, X discharge pilot and with a default (Q) setting of the differential regulator)

### 10.1 - Characteristic curves of the PQC regulator (values obtained with mineral oil with a viscosity of 36 cSt at 50°C)

The diagram curves were measured with a pump rotation speed of 1500 rpm and an oil temperature of 50°C.

#### FLOW RATE / PRESSURE FEATURE

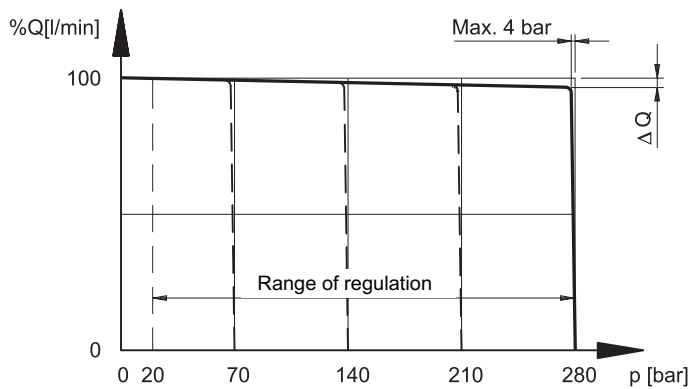

**Flow variation between minimum and maximum pressure with pump set at max displacement**

pump size	$\Delta Q$ max [l/min]
<b>029</b>	0.9
<b>046</b>	1.7
<b>073</b>	2.5

#### FLOW RATE / ROTATION SPEED STATIC FEATURE

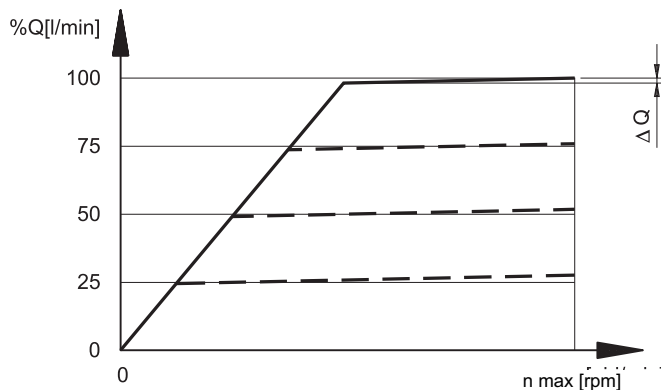



## 11 - INTEGRATED PROPORTIONAL FLOW AND PRESSURE CONTROL REGULATOR: PQCE

### FUNCTIONAL DIAGRAM

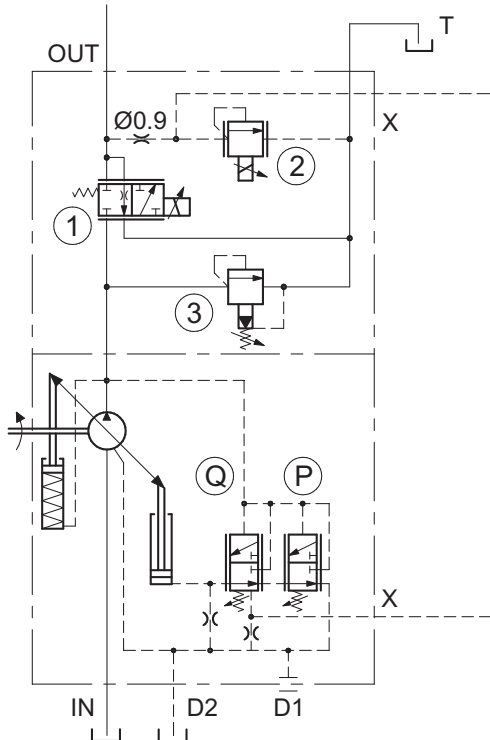

This regulator allows an independent regulation of the pump flow and pressure, both with an electric proportional control.

The pump flow is regulated through the proportional valve (1) which operates directly on the pump delivery, while the system pressure is controlled by means of the proportional relief valve (2) working as a pilot stage of the differential regulator (Q).

The maximum system pressure is limited by the regulator (P). The regulator is also equipped of a built-in pressure relief valve (3) with manual adjustment, which limits the pressure peak due to quick flow variations in the system.

### PQCE5 FEATURES

- pressure regulating range (P) = 20 ÷ 350 bar
- default setting (P) = 280 bar
- differential pressure regulating range (Q) = 10 ÷ 30 bar
- default setting = 16 bar
- proportional pressure regulating range:  
20 ÷ 250 bar (for VPPM-\*PQCE5 pump)
- proportional flow regulating range:  
0 ÷ 69 l/min (for VPPM-046 PQCE5 pump)  
0 ÷ 109,5 l/min (for VPPM-073 PQCE5 pump)

### PERFORMANCES and ELECTRICAL CHARACTERISTICS

	FLOW REGULATION (1) (DSE5 valve)	PRESSURE REGULATION (2) (CRE valve)
<b>HYSTERESIS</b>	< 6% of Q max	< 5% of p nom
<b>REPEATABILITY</b>	< ±1,5% of Q max	< ±1,5% of p nom
<b>NOMINAL VOLTAGE</b>	24 VCC	24 VCC
<b>COIL RESISTANCE (at 20°C)</b>	8,65 Ω	16,6 Ω
<b>MAXIMUM CURRENT</b>	1,6 A	0,85 A
<b>ELECTROMAGNETIC COMPATIBILITY (EMC)</b> emissions EN 50081-1 immunity EN 50082-2	According to 89/336 CEE	
<b>DEGREE OF PROTECTION :</b> Atmospheric agents (CEI EN 60529)	IP 65	
<b>ELECTRONIC CONTROL UNITS</b> for proportional valves	EDM-M3312 see cat. 89 250	



## 11.1 - Characteristic curves of the PQCE5 regulator (values obtained with mineral oil with a viscosity of 36 cSt at 50°C)

The diagram curves were measured with a pump rotation speed of 1500 rpm and an oil temperature of 50°C.

**FLOW RATE / PRESSURE CURVE**

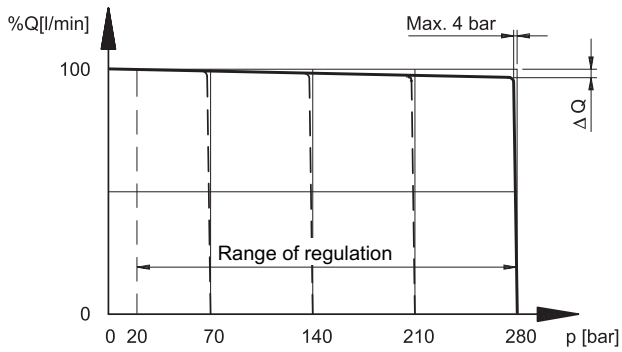

**Flow variation between minimum and maximum pressure with pump set at max displacement**

pump size	$\Delta Q$ max [l/min]
<b>046</b>	1.7
<b>073</b>	2.5

**CURRENT / FLOW CURVE**

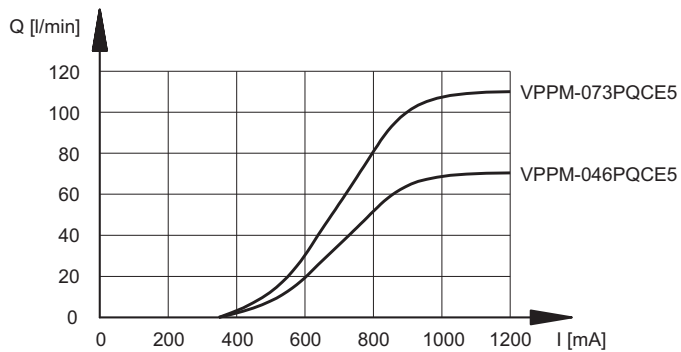

**CURRENT / PRESSURE CURVE**

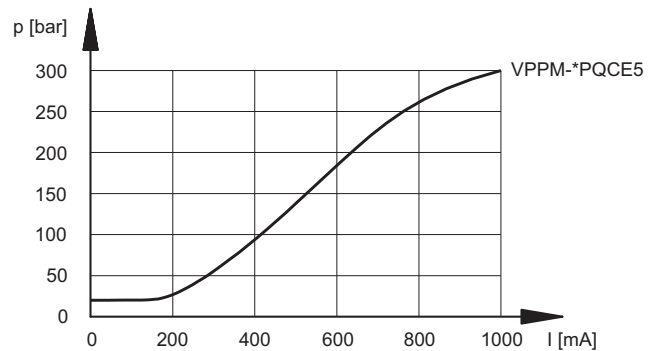





## 12 - POWER REGULATOR: PQNC

### FUNCTIONAL DIAGRAM

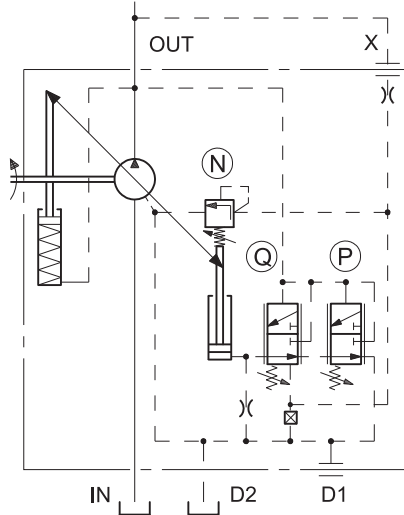

Such regulator keeps the pump torque at a constant level by changing the displacement according to the delivery pressure, so that the ratio  $p \times (Q)$  (absorbed power) remains unchanged. The functions limiting the (P) maximum pressure and regulating the (Q) flow rate are always present, if a restrictor has been installed on the user line.

In the 1/8" BSP coupling supplied for the X port, there is a restrictor of  $\varnothing 0,8$  orifice.

**Note:** The connection pipe between the X port and the pump outlet must always be made (customer charge).

#### PQNC FEATURES:

- pressure regulating range (P) = 20 ÷ 350
- default setting (P) = 280 bar
  
- differential pressure regulating range (Q) = 10 ÷ 30 bar
- default setting = 16 bar
  
- min. discharge head =  $18 \pm 2$  bar  
(with a zero flow rate, X discharge pilot and with a default Q setting of the differential regulator)
- the power regulator is factory set. The setting value has to be specified with the order, by stating into the identification code the Nm torque value (see paragraph 1).
- Start of the regulation: looking at values table of paragraph 1.5

### 12.1 - Characteristic curves of the PQNC regulator (values obtained with mineral oil with a viscosity of 36 cSt at 50°C)

The diagram curves were measured with a pump rotation speed of 1500 rpm and an oil temperature of 50°C.

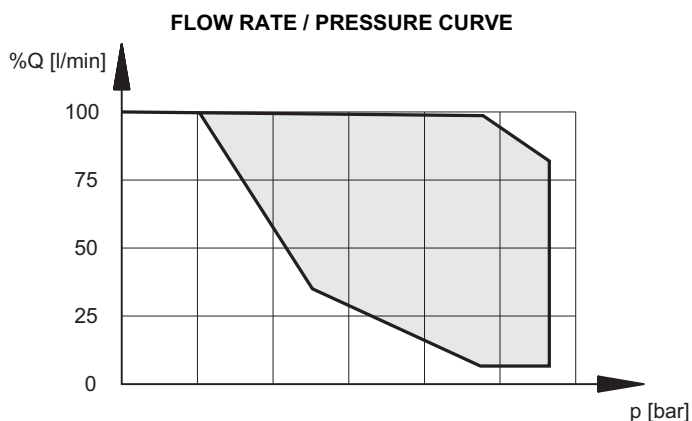



## 13 - POWER REGULATOR WITH INTEGRATED PROPORTIONAL FLOW AND PRESSURE CONTROL: PQNCE5

### FUNCTIONAL DIAGRAM

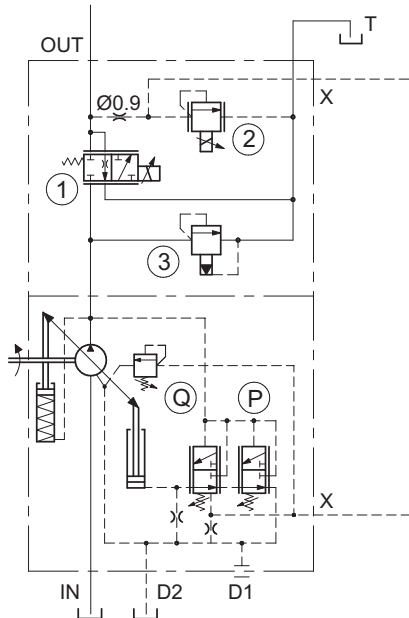

This system combines all the functions of the constant power control as a standard PQNCE5 regulator, and moreover it allows the independent proportional regulation of the pump flow and pressure at values behind the power curve characteristic set on the regulator (N).

### PQNCE5 FEATURES

For technical characteristics and settings of regulator, see paragraph 12.

### 13.1 - Characteristic curves of the PQNCE5 regulator (values obtained with mineral oil with viscosity of 36 cSt at 50°C)

The diagram curves were measured with a pump rotation speed of 1500 rpm and an oil temperature of 50°C.

#### FLOW RATE / PRESSURE CURVE

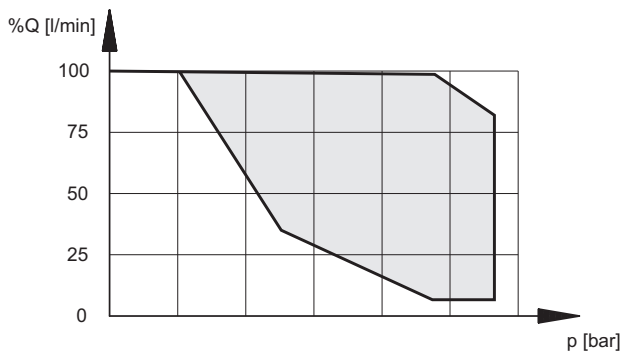

#### CURRENT / FLOW CURVE

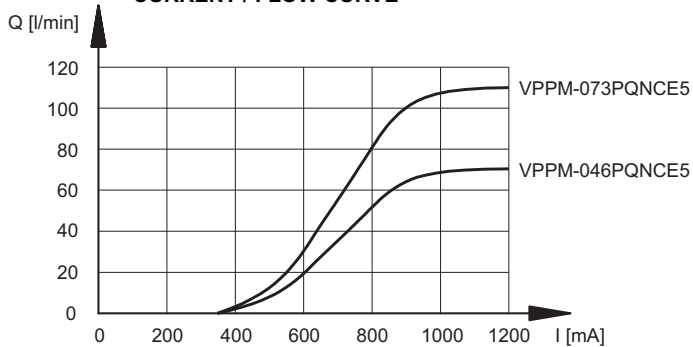

#### CURRENT / PRESSURE CURVE

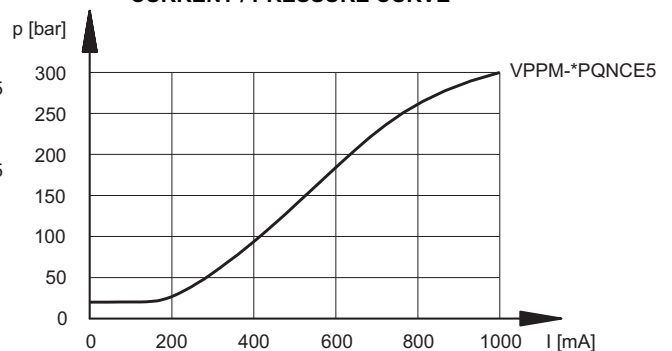



## 14 - REGULATOR OVERALL DIMENSIONS

dimensions in mm

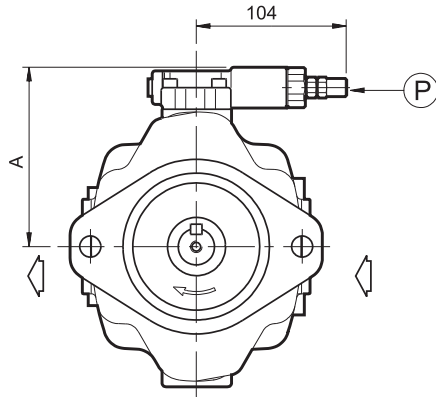

### PRESSURE REGULATOR PC

pump size	A [mm]
<b>029</b>	114
<b>046</b>	123
<b>073</b>	136

P	Pressure regulator countersunk hex adjustment screw: spanner 4 Clockwise rotation to increase pressure
---	---

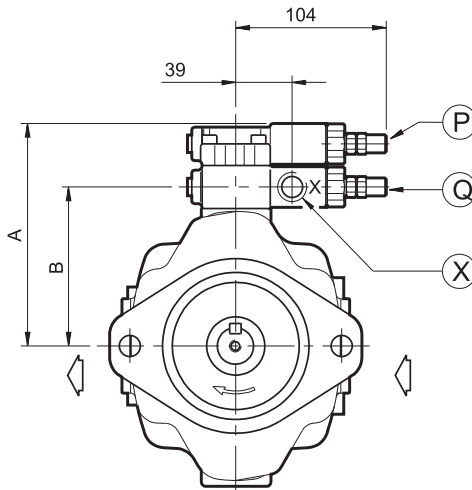

### REMOTE-CONTROLLED PRESSURE REGULATOR PCR

pump size	A [mm]	B [mm]
<b>029</b>	114	100
<b>046</b>	123	109
<b>073</b>	136	122

P	Pressure regulator countersunk hex adjustment screw: spanner 4 Clockwise rotation to increase pressure
Q	Differential pressure regulator countersunk hex adjustment screw: spanner 4 Clockwise rotation to increase differential pressure
X	Pilot port for remote control X: 1/8" BSP



dimensions in mm

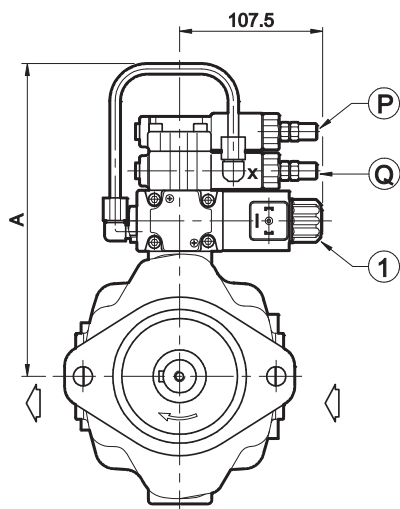

### PCX REGULATOR WITH ELECTRICAL UNLOADING

pump size	A [mm]
<b>029</b>	194
<b>046</b>	203
<b>073</b>	215

P	Pressure regulator countersunk hex adjustment screw: spanner 4 Clockwise rotation to increase pressure
Q	Differential pressure regulator countersunk hex adjustment screw: spanner 4 Clockwise rotation to increase differential pressure
1	Solenoid switching valve type DS3-SA2

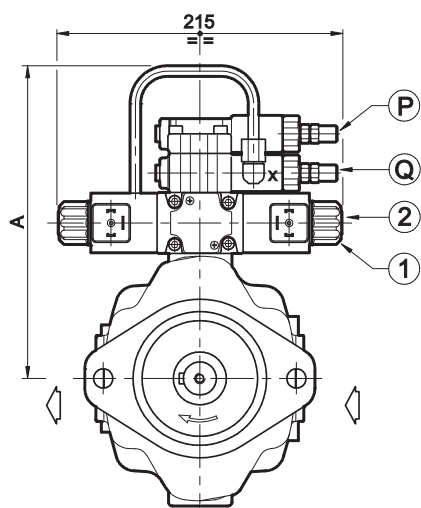

### PCX REGULATOR WITH TWO PRESSURE SETTINGS + UNLOADING

pump size	A [mm]
<b>029</b>	194
<b>046</b>	203
<b>073</b>	215

P	Pressure regulator countersunk hex adjustment screw: spanner 4 Clockwise rotation to increase pressure
Q	Differential pressure regulator countersunk hex adjustment screw: spanner 4 Clockwise rotation to increase differential pressure
1	Solenoid switching valve type DS3-S2
2	Relief valve for the intermediate pressure setting MCI*-SBT

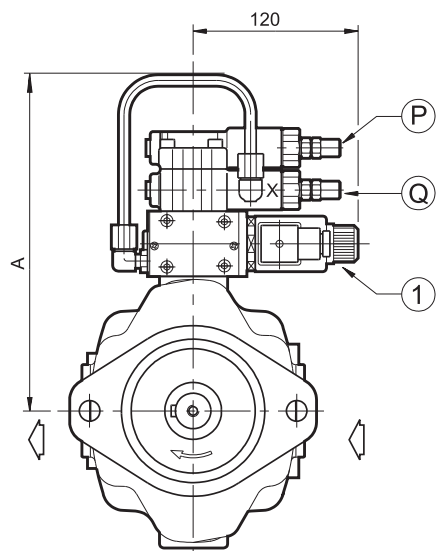

### PCX REGULATOR FOR PRESSURE REGULATION WITH ELECTRIC PROPORTIONAL CONTROL

pump size	A [mm]
<b>029</b>	194
<b>046</b>	203
<b>073</b>	215

P	Pressure regulator adjustment screw: spanner 4 Clockwise rotation to increase pressure
Q	Differential pressure regulator countersunk hex adjustment screw: spanner 4 Clockwise rotation to increase differential pressure
1	Proportional pressure relief valve PRED3 type



dimensions in mm

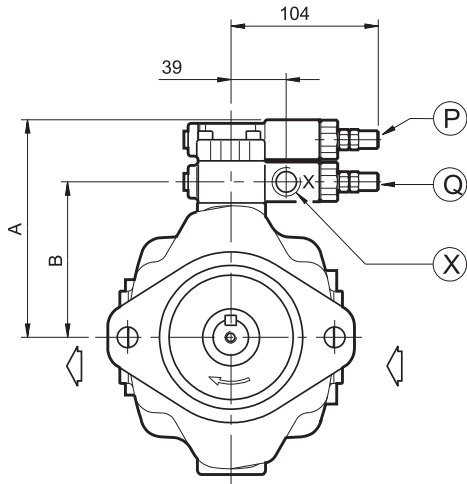

### FLOW RATE AND PRESSURE REGULATOR PQC

pump size	A [mm]	B [mm]
029	114	100
046	153	109
073	165	122

P	Pressure regulator countersunk hex adjustment screw: Spanner 4 Clockwise rotation to increase pressure
Q	Differential pressure regulator countersunk hex adjustment screw: spanner 4 Clockwise rotation to increase differential pressure
X	Pilotage port X: 1/8" BSP (see paragraph 11)

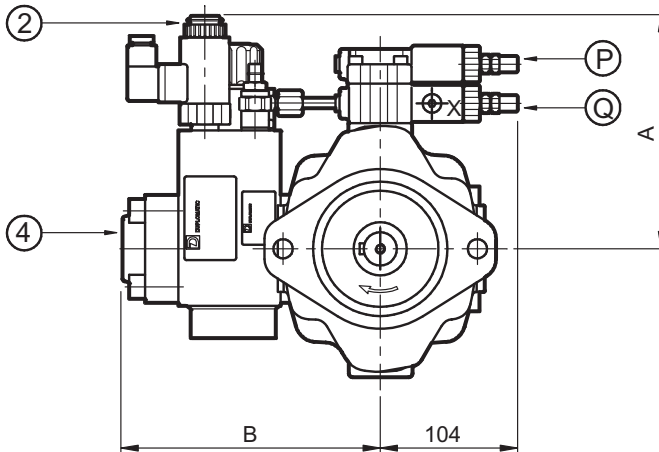

### PQCE REGULATOR WITH INTEGRATED PROPORTIONAL FLOW AND PRESSURE CONTROL

pump size	A [mm]	B [mm]	C [mm]
046	175	194	321
073	181	207	350

P	Pressure regulator countersunk hex adjustment screw: Spanner 4 Clockwise rotation to increase pressure
Q	Differential pressure regulator countersunk hex adjustment screw: spanner 4 Clockwise rotation to increase differential pressure
1	Proportional flow control valve type: DSE5-P070B - DSE5-P100SB
2	Proportional pressure valve type: CRE-250
3	Safety pressure relief valve
4	Delivery port SAE 6000 flange 1" for VPPM-046 - 1 1/4" for VPPM-073

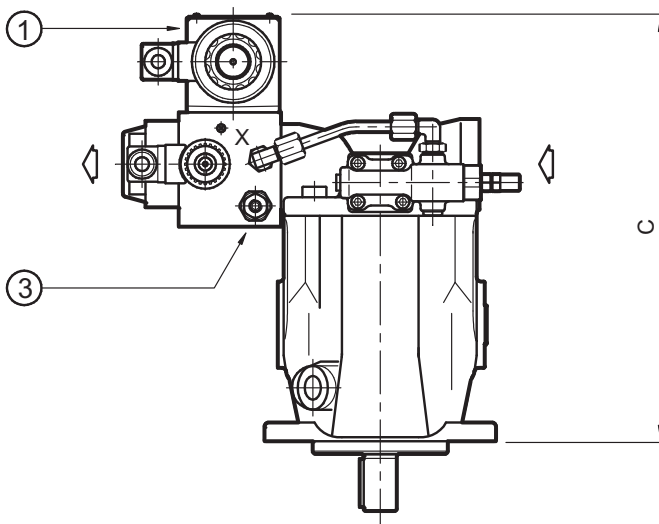

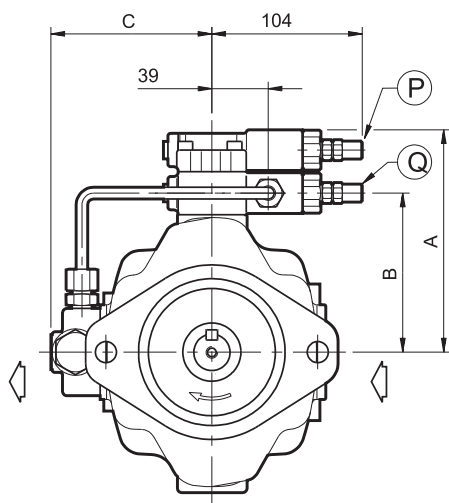

### POWER REGULATOR PQNC

dimensions in mm

grandezza pompa	A [mm]	B [mm]	C [mm]	D [mm]
<b>029</b>	144	100	104	211
<b>046</b>	153	109	111	235
<b>073</b>	165	122	120	258

P	Pressure regulator countersunk hex adjustment screw: spanner 4 Clockwise rotation to increase pressure
Q	Differential pressure regulator countersunk hex adjustment screw: spanner 4 Clockwise rotation to increase differential pressure
X	Pilotage port X: 1/8" BSP (restrictor with Ø0,8 orifice included - see paragraph 13)
N	Power regulator

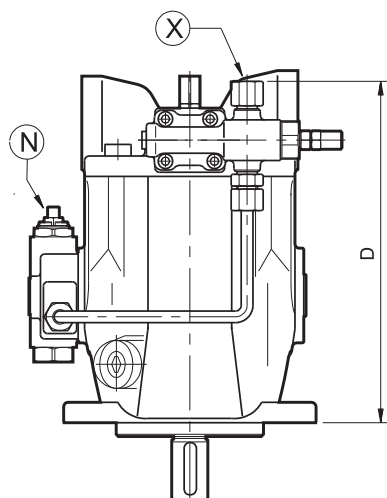

### POWER REGULATOR WITH INTEGRATED PROPORTIONAL FLOW AND PRESSURE CONTROL PQNCE5

(for dimensions see PQCE5 page 21)

P	Pressure regulator countersunk hex adjustment screw: spanner 4. Clockwise rotation to increase pressure
Q	Differential pressure regulator countersunk hex adjustment screw: spanner 4 Clockwise rotation to increase differential pressure
N	Power regulator
1	Proportional flow control valve type: DSE5-P070SB - DSE5-P100SB
2	Proportional pressure control valve type: CRE-250
3	Safety pressure relief valve
4	Delivery port SAE 6000 flange: 1" for VPPM-046 - 1 1/4" for VPPM-073
5	Outlet port T: 3/4" BSP

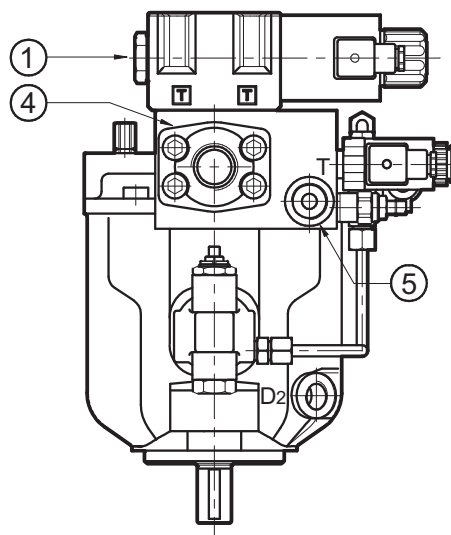
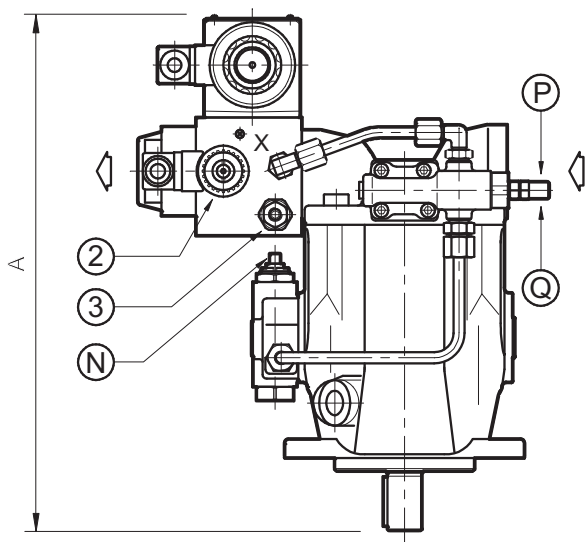



## 15 - VPPM-029 OVERALL AND MOUNTING DIMENSIONS

dimensions in mm

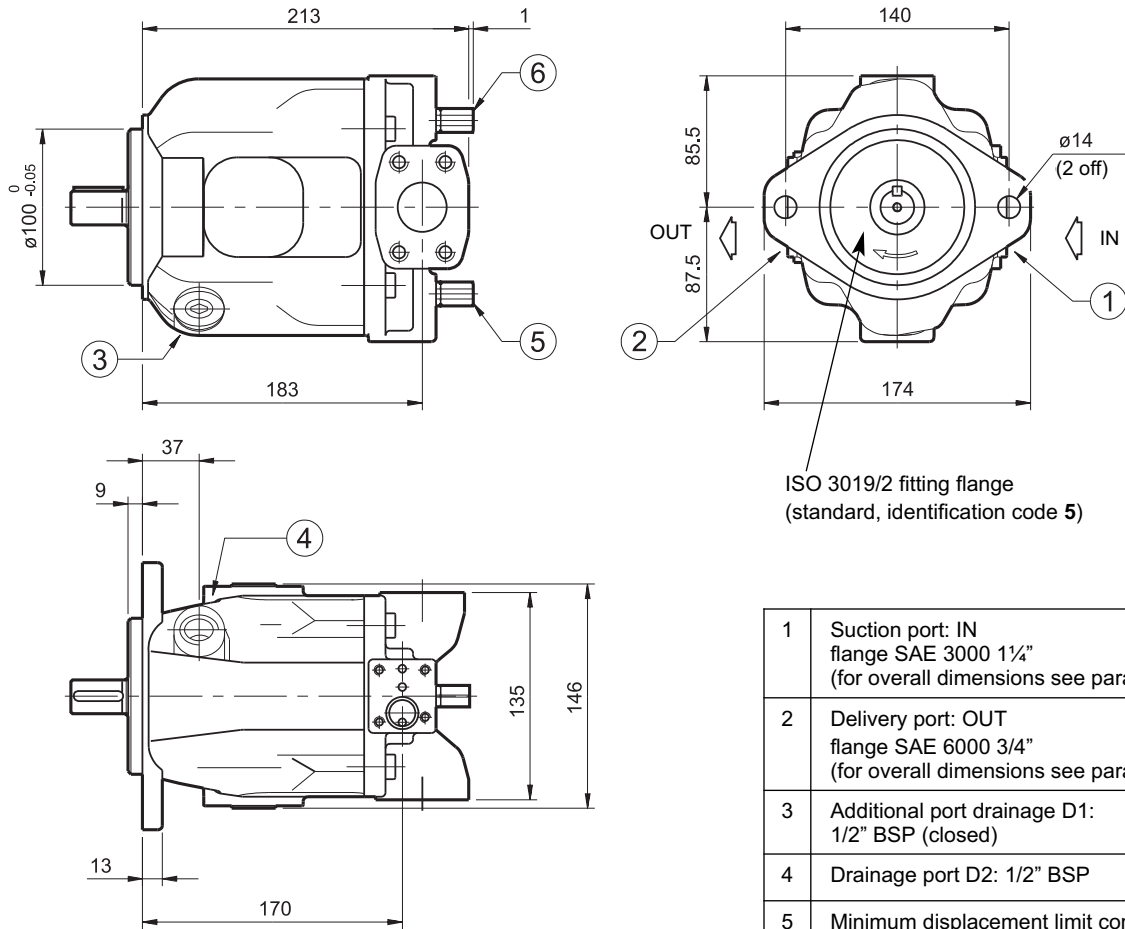

ISO 3019/2 fitting flange  
(standard, identification code 5)

1	Suction port: IN flange SAE 3000 1¼" (for overall dimensions see paragraph 24)
2	Delivery port: OUT flange SAE 6000 3/4" (for overall dimensions see paragraph 24)
3	Additional port drainage D1: 1/2" BSP (closed)
4	Drainage port D2: 1/2" BSP
5	Minimum displacement limit control ( <b>NOTE</b> ) - protection plug: spanner 14 - countersunk hex adjustment screw: spanner 4 - displacement regulation range: 0 ÷ 50 % max. displacement
6	Maximum displacement limit control - protection plug: spanner 14 - countersunk hex adjustment screw: spanner 4 - displacement regulation range: 100 ÷ 50 % max. displacement

Cylindrical shaft end with ISO 3019/2 key  
(standard, identification code 5)

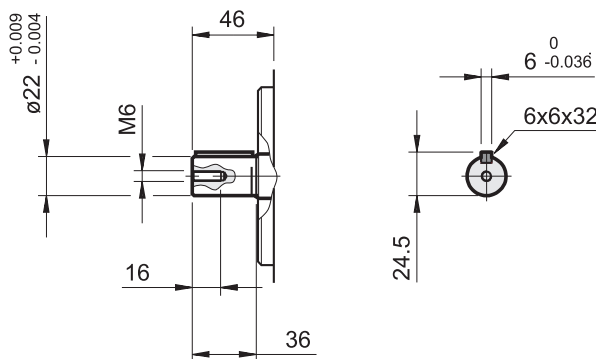

**NOTE:** The limit control is supplied factory set at zero minimum displacement and is sealed up with red paint.

Any modification of this setting by the user makes the pump unable to reach the null displacement condition.



## 16 - VPPM-046 OVERALL AND MOUNTING DIMENSIONS

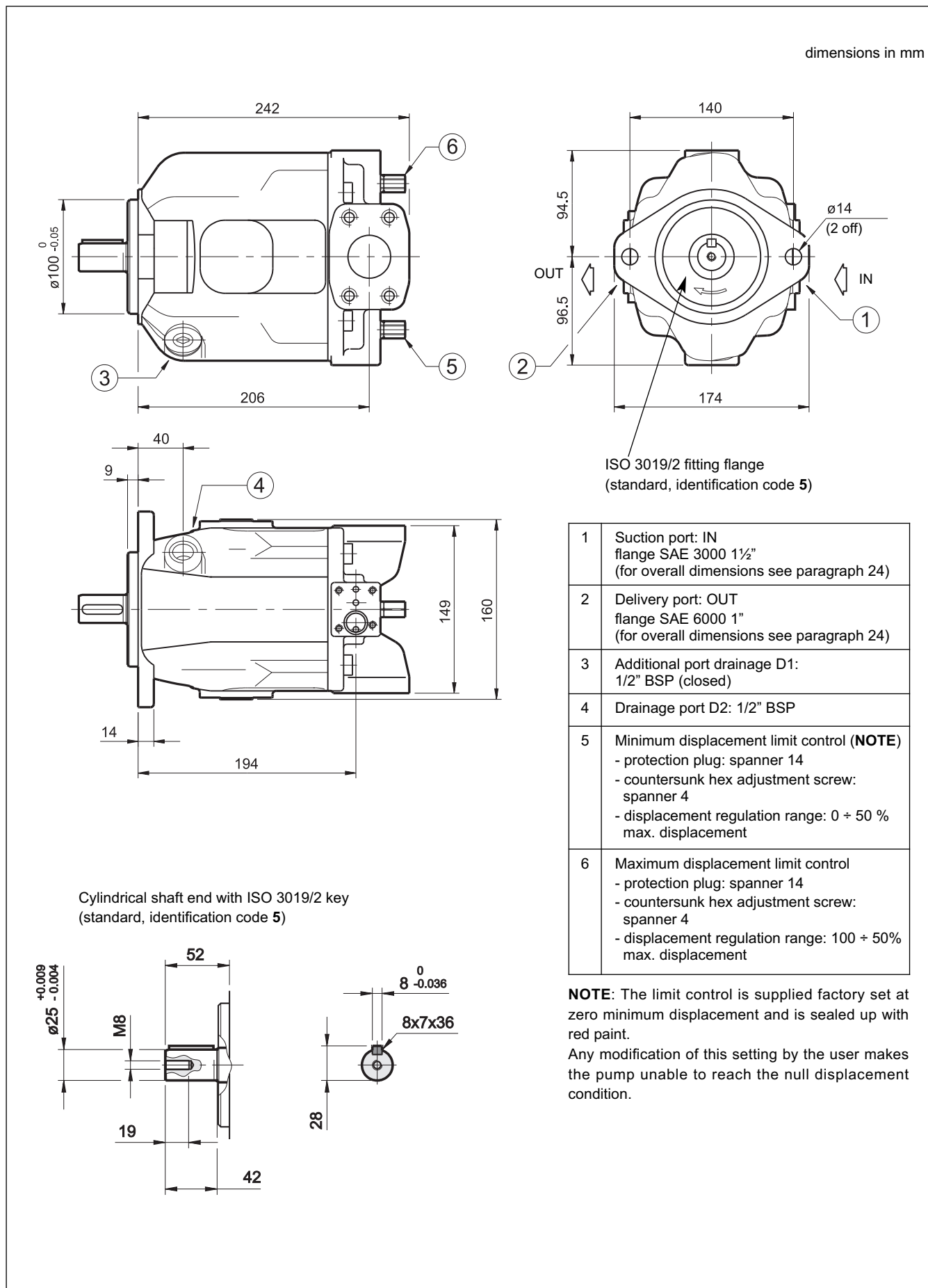





## 17 - VPPM-073 OVERALL AND MOUNTING DIMENSIONS

dimensions in mm

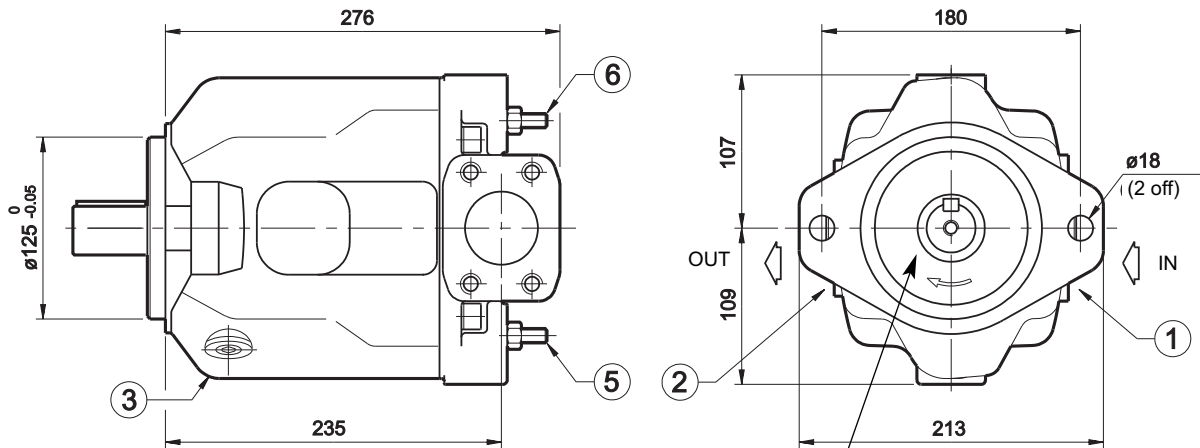

ISO 3019/2 fitting flange  
(standard, identification code 5)

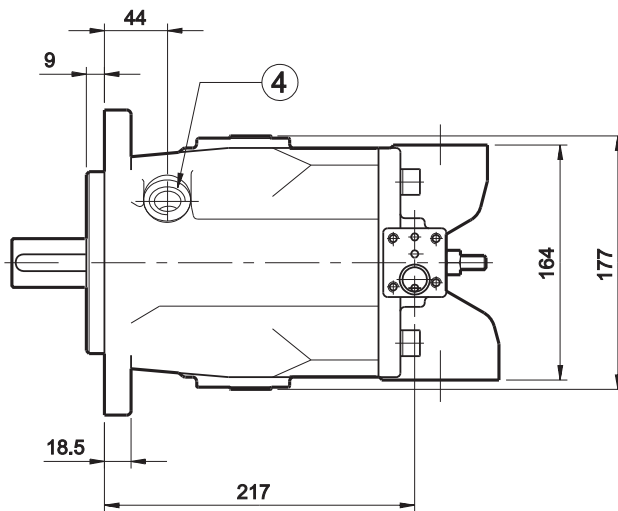

Cylindrical shaft end with ISO 3019/2 key  
(standard, identification code 5)

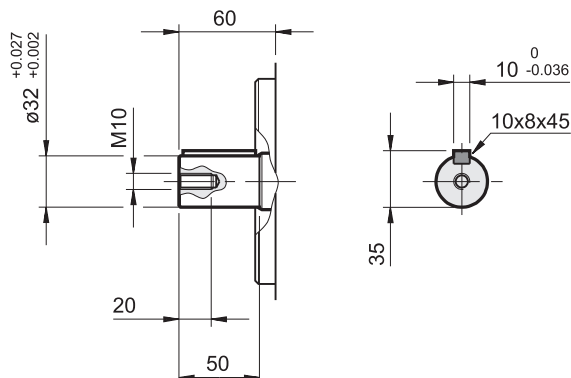

1	Suction port: IN flange SAE 3000 2" (for overall dimensions see paragraph 24)
2	Delivery port: OUT flange SAE 6000 1 1/4" (for overall dimensions see paragraph 24)
3	Additional port drainage D1: 1/2" BSP (closed)
4	Drainage port D2: 1/2" BSP
5	Minimum displacement limit control ( <b>NOTE</b> ) - protection plug: spanner 14 - countersunk hex adjustment screw: spanner 4 - displacement regulation range: 0 ÷ 50 % max. displacement
6	Maximum displacement limit control - protection plug: spanner 14 - countersunk hex adjustment screw: spanner 4 - displacement regulation range: 100 ÷ 50% max. displacement

**NOTE:** The limit control is supplied factory set at zero minimum displacement and is sealed up with red paint.

Any modification of this setting by the user makes the pump unable to reach the null displacement condition.



## 18 - OVERALL DIMENSIONS FOR FLANGES AND SHAFTS TYPE SAE J744

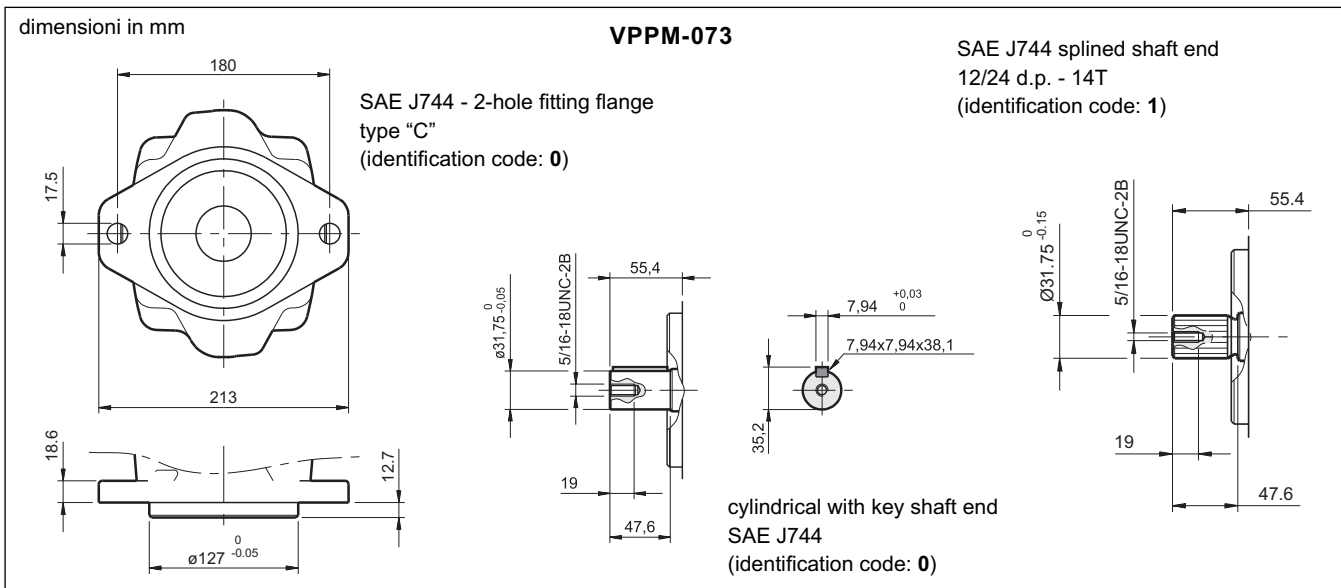
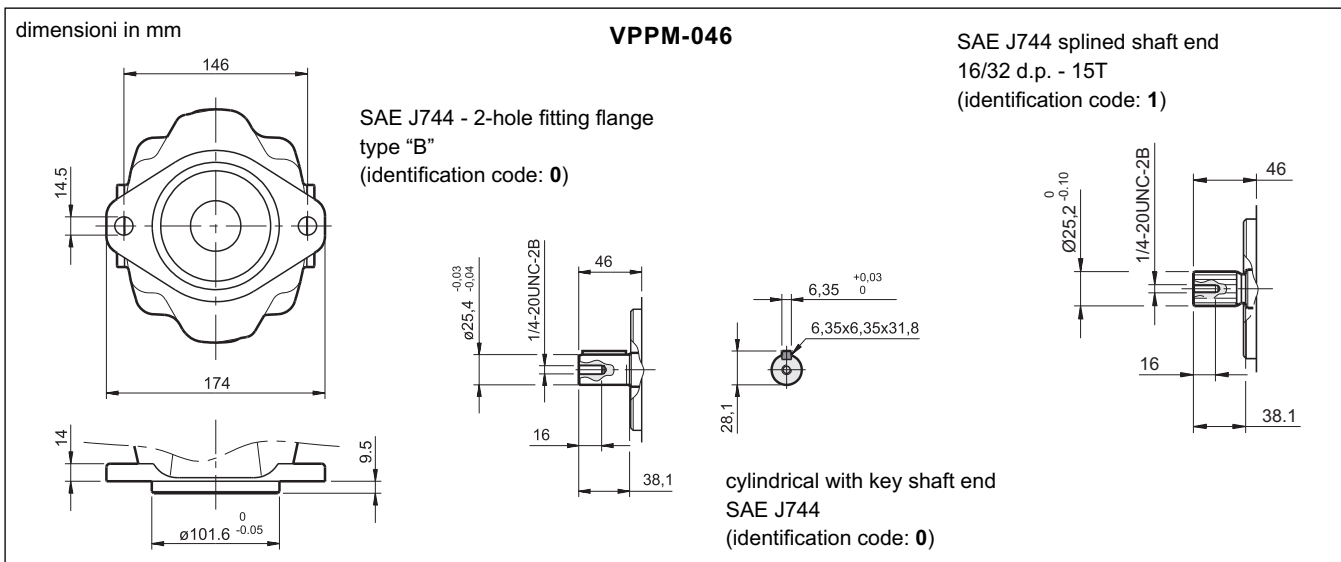
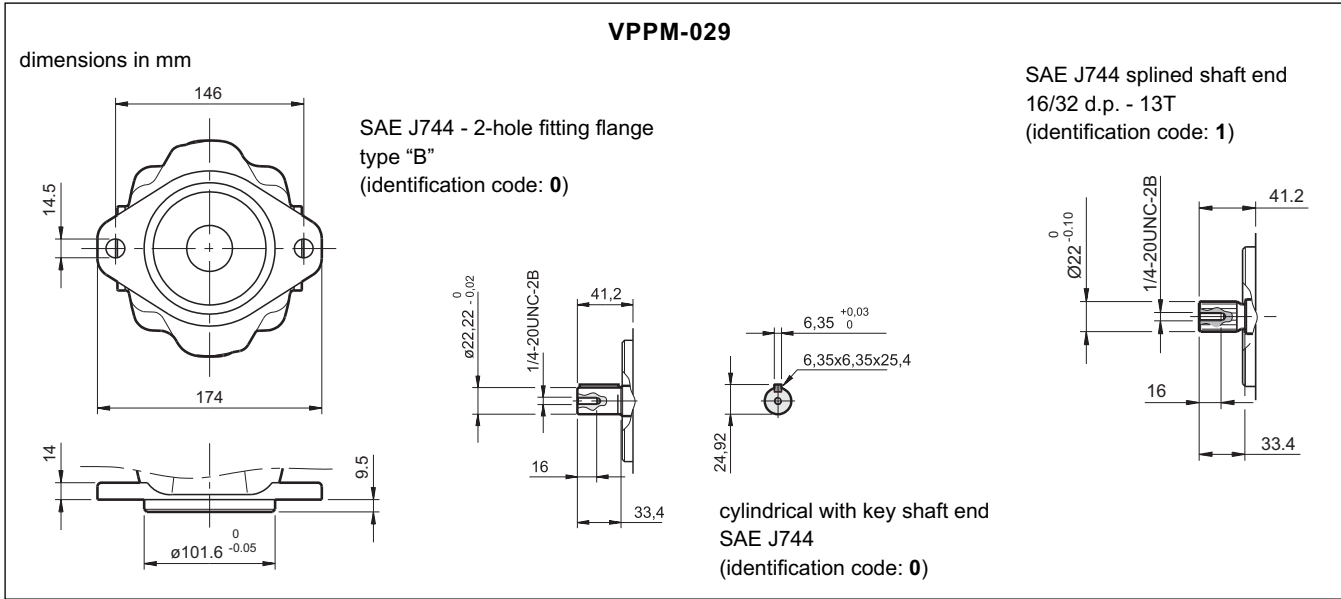



## 19 - INSTALLATION

- The VPPM pumps can be installed both in a horizontal and vertical position, with the shaft in an upward position.  
N.B.: The drainage port has to be oriented so that the oil level inside the pump body is never lower than 3/4 of its volume (according to the installation use the D1 or D2 drainage ports).
- Installation below the oil reservoir is suggested. As for an installation above the oil level, check that the min. suction pressure is not lower than -0.2 bars (relative). If a low noise emission level is required, the installation inside the tank is suggested.  
In case of an installation inside the tank, with an oil level which does not grant complete pump submersion, it is suggested that the drain tube is adjusted so that the pump higher bearing can be always lubricated.
- **Before starting, the pump body has to be filled with the fluid.**
- It is necessary to vent the air from the delivery connection before operating it the first time.  
The pump start up, especially at a cold temperature, should occur with the plant at minimum pressure.
- The suction tube has to be suitably sized so that the suction pressure is never lower than -0.2 bar (relative). Bends or restrictions or an excessive tube length could further decrease the value of the suction pressure with a following increase in the noise emissions and a decrease in the pump lifetime.
- The drainage tube has to be sized so that the pressure inside the pump body is always lower than 0.5 bars (relative), even during the dynamic change and flow rate phases.  
The drainage tube has to unload inside the tank far from the suction area.
- No check valves allowed on the suction line
- The motor-pump connection must be carried out directly with a flexible coupling. Radial and axial loads have to be lower than the values specified in the table "Technical specifications".
- As for details and the installation of filter elements, see par. 2.3.

## 20 - THROUGH OUTPUT SHAFT

The VPPM pumps can be supplied with a through output shaft, which allows coupling with other pump models.

**N.B.: The pumps with a through output shaft are supplied with an intermediate 2-hole flange type SAE J744 - and with a mating joint for splined shaft type SAE J744.**

**In this version the mechanical adjustment for the min. and max. displacement are not available.**

- As for identification see par. 1 "Identification code".
- For the pump overall dimensions (intermediate flange included) see paragraph 22 "overall dimensions for multiple pumps".

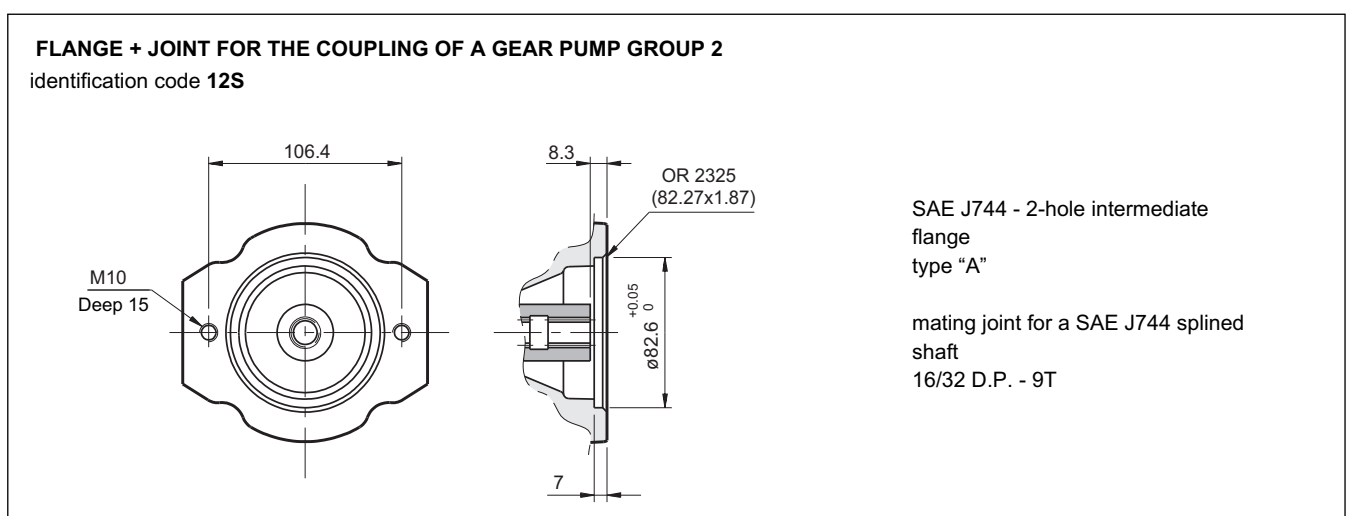



## FLANGE + JOINT FOR THE COUPLING OF A PUMP TYPE VPPM-029 OR OF A GEAR PUMP GROUP 3

identification code **62S**

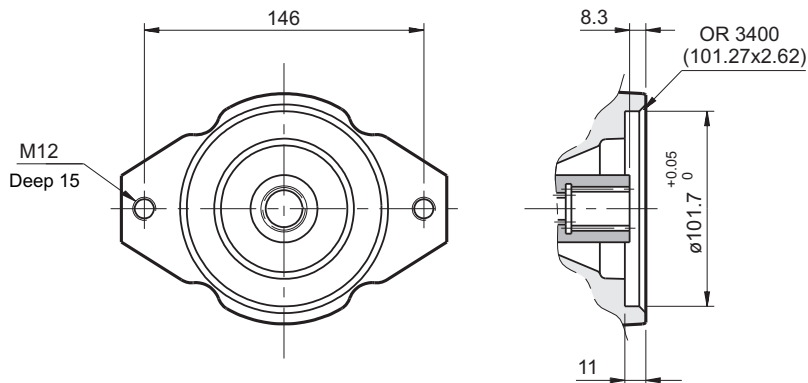

SAE J744 - 2-holes intermediate flange  
type "B"

mating joint for a SAE J744 splined shaft  
16/32 D.P. - 13T

## FLANGE + JOINT FOR THE COUPLING OF A PUMP TYPE VPPM-046

identification code **63S**

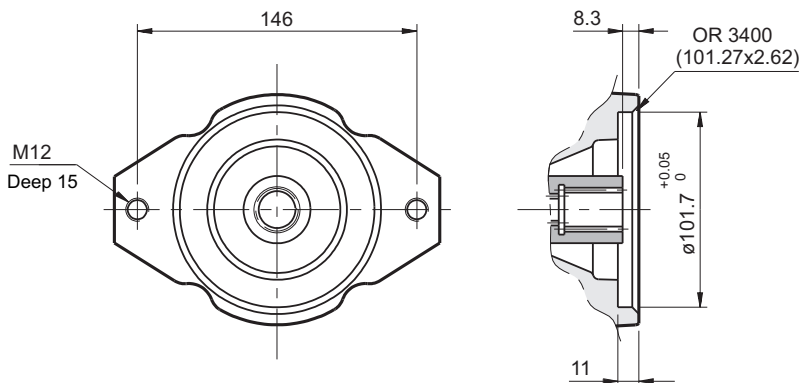

SAE J744 - 2-holes intermediate flange  
type "B"

mating joint for a SAE J744 splined shaft  
16/32 D.P. - 15T

## FLANGE + JOINT FOR THE COUPLING OF A PUMP TYPE VPPM-073

identification code **64S**

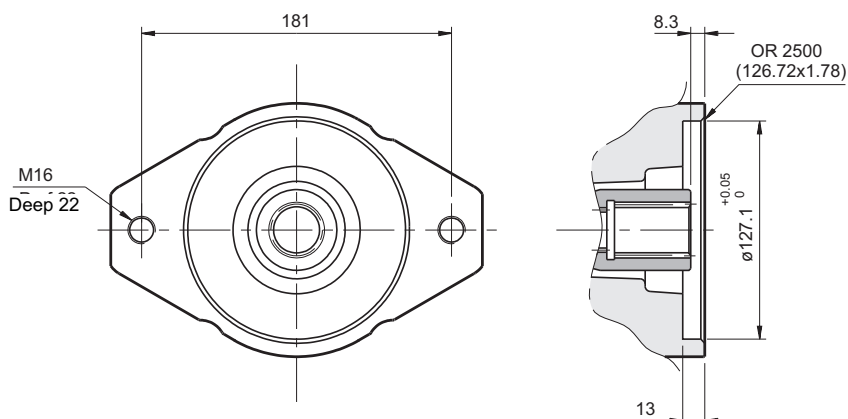

SAE J744 - 2-holes intermediate flange  
type "C"

mating joint for a SAE J744 splined shaft  
12/24 D.P. - 14T



## 21 - MULTIPLE PUMPS

The possibility to couple several pumps makes it possible to create multi-flow groups with independent hydraulic circuits. While sizing coupled pumps, it's necessary to make reference to the following conditions:

- The coupling can be carried out between pumps with the same dimensions or to a size of decreasing order.
- The max. rotation speed is determined by the pump with the lowest speed.
- The values of the max. applicable torque can not be exceeded.

### 21.1 - Max. applicable torque

The input torque (M) for each pump is given by the following ratio:

$$M = \frac{9550 \cdot N}{n} = [\text{Nm}]$$

n = rotation speed [rpm]

where the absorbed power (N) is given by:

$$N = \frac{Q \cdot \Delta p}{600 \cdot \eta_{\text{tot}}} = [\text{kW}]$$

Q = flow rate [l/min]

$\Delta p$  = differential pressure between the pump suction and delivery [bar]

$\eta_{\text{tot}}$  = total efficiency (obtainable from the diagrams in par. 4-5-6)

or it can be obtained from the diagrams ABSORBED POWER (see par. 4 - 5 - 6).

If several pumps are coupled, the torque of each single pump has to be added to the torque of subsequent pumps when they are loaded simultaneously.

The obtained torque value for each pump has to be lower than the value specified in the table below :

pump with a through output shaft	MAXIMUM TORQUE APPLICABLE AT THE FRONT PUMP SHAFT [Nm]			MAXIMUM TORQUE APPLICABLE AT THE PUMP TO BE COUPLED [Nm] (not simultaneously to the front pump)				
	cylindrical ISO 3019/2 (cod. 5)	cylindrical SAE J744 (cod. 0)	splined SAE J744 (cod. 1)	GP2 external gear	GP3 external gear	VPPM-029	VPPM-046	VPPM-073
<b>VPPM-029</b>	160	155	190	100	135	135	-	-
<b>VPPM-046</b>	245	220	330	135	220	190	220	-
<b>VPPM-073</b>	400	400	620	135	330	190	330	400

The maximum transmissible torque for those pumps with a through output shaft is determined by the coupling used for the transmission. If the obtained torque values are higher than the ones stated in the table, it is necessary to reduce the working pressure value or to replace the overloaded pump with a pump suitable to bear the required torque.



## 22 - OVERALL DIMENSIONS FOR MULTIPLE PUMPS

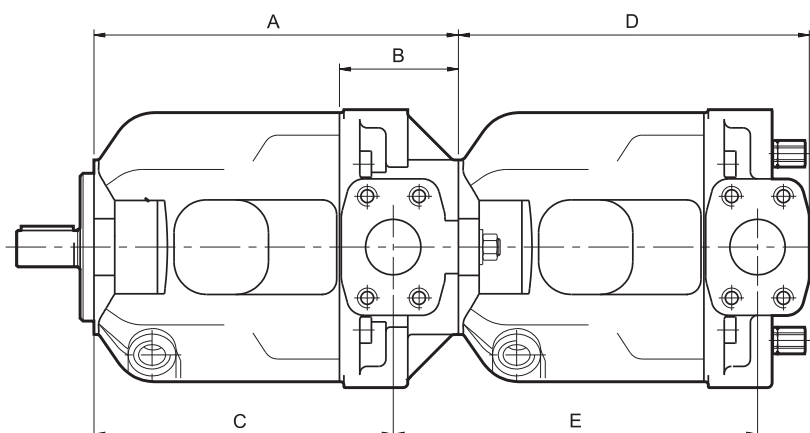

dimensions in mm

	REAR PUMP														
	VPPM-029					VPPM-046					VPPM-073				
	A	B	C	D	E	A	B	C	D	E	A	B	C	D	E
<b>VPPM-029</b>	222	77	183	213	222	-	-	-	-	-	-	-	-	-	-
<b>VPPM-046</b>	251	82	206	213	220	251	82	206	242	251	-	-	-	-	-
<b>VPPM-073</b>	291	99	235	213	226	291	99	235	242	249	296	104	235	276	296

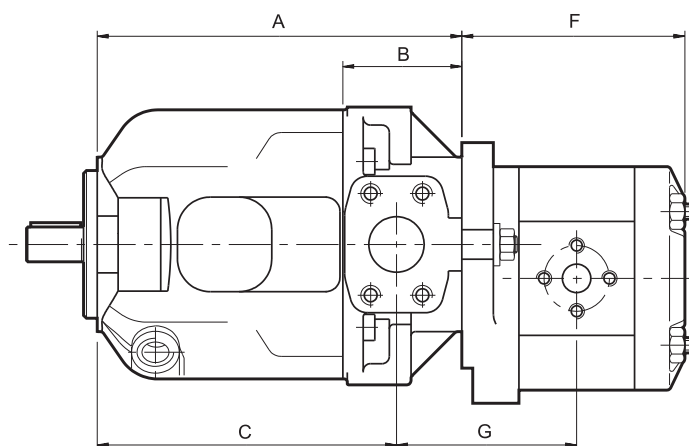

	REAR PUMP									
	external gear GP2					external gear GP3				
	A	B	C	F	G	A	B	C	F	G
<b>VPPM-029</b>	222	77	183	99 + 121	86 + 97	-	-	-	-	-
<b>VPPM-046</b>	251	82	206	99 + 121	85 + 96	251	82	206	132 + 147	103 + 110
<b>VPPM-073</b>	291	99	235	99 + 121	91 + 102	291	99	235	132 + 147	109 + 116

**NOTE:** The F and G values in the table make reference to the dimensions of the gear pumps according to the available min. and max. displacement range. For further details apply to our Technical department.



## 23 - SUCTION AND DELIVERY PORTS DIMENSIONS FOR SAE FLANGE WITH METRIC BOLTS

SUCTION PORT : "IN" (SAE 3000)					
Code	Nominal size	A mm	B mm	C mm	D Threading and depth (mm)
VPPM-029	1 1/4"	32	58,7	30,2	M10 x 28
VPPM-046	1 1/2"	38,1	70	35,7	M12 x 26
VPPM-073	2"	50,8	77,8	43	M12 x 25

DELIVERY PORT : "OUT" (SAE 6000)					
Code	Nominal size	A mm	B mm	C mm	D Threading and depth (mm)
VPPM-029	3/4"	19	50,8	23,8	M10 x 24
VPPM-046	1"	25,4	57,1	27,7	M12 x 20
VPPM-073	1 1/4"	32	66,7	31,7	M14 x 23

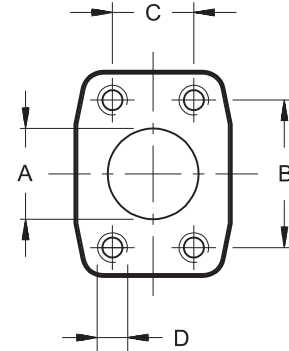

## 24 - CONNECTION FLANGES

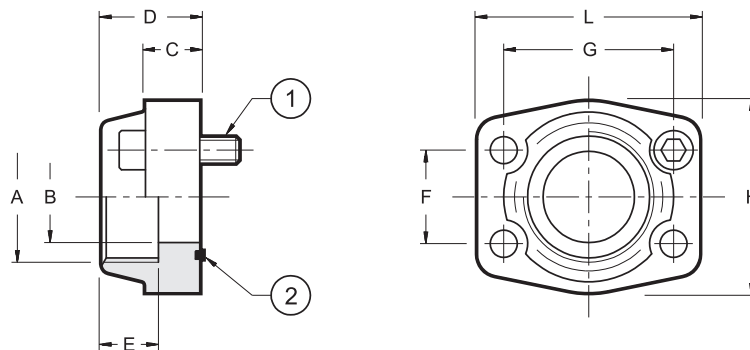

dimensions in mm  
The fastening bolts and the O-Rings must be ordered separately

	Flange code	Flange description	P <sub>max</sub> [bar]	ØA	ØB	C	D	E	F	G	H	L	1 bolts TCEI	2
SAE 3000	0610720	SAE - 1 1/4"	280	1 1/4" BSP	32	21	41	22	30,2	58,7	68	79	n° 4 - M10x35	OR 4150 (37.69x3.53)
	0610714	SAE - 1 1/2"	210	1 1/2" BSP	38	25	45	24	35,7	70	78	94	n° 4 - M12x45	OR 4187 (47.22x3.53)
	0610721	SAE - 2"	210	2" BSP	51	25	45	30	43	77,8	90	102	n° 4 - M12x45	OR 4225 (56.74x3.53)
SAE 6000	0770075	SAE - 3/4"	420	3/4" BSP	19	21	35	22	23,8	50,8	55	71	n° 4 - M10x35	OR 4100 (24.99x3.53)
	0770092	SAE - 1"	420	1" BSP	25	25	42	24	27,7	57,1	65	81	n° 4 - M12x45	OR 4131 (32.93x3.53)
	0770106	SAE - 1 1/4"	420	1 1/4" BSP	32	27	45	25	31,7	66,7	78	95	n° 4 - M14x50	OR 4150 (37.69x3.53)



# VPPM

 <p><b>DIPLOMATIC HYDRAULICS</b></p>	<p><b>DIPLOMATIC OLEODINAMICA SpA</b> 20025 LEGNANO (MI) - P.le Bozzi, 1 / Via Edison Tel. 0331/472111 - Fax 0331/548328</p>	
---	--	--