

HD09 Series

Smart Inverter

User Manual

Single-phase 220 - 240V, 0.25 - 2.2kW

Three-phase 380 - 460V, 0.4 - 5.5kW



V1.1 2017.07

FOREWORD

Thank you for purchasing HD09 series smart inverter manufactured by Shenzhen Hpmont Technology Co., Ltd.

This User Manual describes how to use HD09 series inverters and their installation wiring, parameter setting, troubleshooting and daily maintenance etc.

Before using the product, please read through this User Manual carefully. In addition, please do not use this product until you have fully understood safety precautions.

Note:

- Preserve this Manual for future use.
- If you need the User Manual due to damage, loss or other reasons, please contact the regional distributor of our company or directly contact our company Technical Service Center.
- If you still have some problems during use, please contact our company Technical Service Center.
- Due to product upgrade or specification change, and for the purpose of improving convenience and accuracy of this manual, this manual's contents may be modified.
- Telephone: **4008-858-959** or **189 4871 3800**

Version and Revision Records

Version information: At the bottom right corner of the front cover.

Time: 2017/07

Version: V1.1

Revised chapter	Revised contents
Chapter 4 Chapter 5	<ul style="list-style-type: none"> AI terminals can be selected as DI input, see clause 4.2 Modify input and output routh, see clause 5.1.1 Add selection of power terminals wiring lugs, see clause 5.1.2
Chapter 8	<ul style="list-style-type: none"> Add F00.17 (Running direction), F00.19 (Dead time from positive rotation to oppositive rotation), F00.20 (External keypad), F00.21 – F00.25 (Sleep function) Add parameter copy function: F01.02 add function 2/3, add parameter F00.13 Add F03.03 – F03.16 (Ace. and Dec. parameter) Modify F04.16 (Integral regulation selection) default value: [0] Modify F06.01 - F06.06 (Multi-frequency) default value: [5.0Hz] Add F08.04 (Rated Rpm of motor) Add F09.09 – F09.12 (Motor compensation function), F09.14 (Auto-voltage adjustment function). Modify defination of F09.15: Oscillation-suppression mode Add F15.44 (AI as function of DI). DI function (F15.00 – F15.03, F15.44) add: 26/27 (Ace. and Dec. time selection) Modify F17.03 (Host PC response time) default: [1ms], add F17.10 (Detecting time when network communication over time) Add group F18 (Display control parameter) Add F19.12 – F19.15 (Instant power failure without stop), F17.37 (Frequency adjust range), F17.39 (Input voltage) Add F20.00 (Over-load protection function)



CONTENTS

Chapter 1 Safety Information	1
Chapter 2 Product Information	3
2.1 Nameplate.....	3
2.2 Rated Value	4
Chapter 3 Macheanical Installation	5
3.1 Dimension and Weight.....	5
3.2 Requirement for the Installation Site	6
3.3 Installation of Exterior Keypad.....	7
Chapter 4 Electrical Installation	9
4.1 Power Terminals and Connection.....	10
4.2 Control Terminals and Connection.....	11
4.3 External Keypad or Upper Computer	14
Chapter 5 Technical Data	15
5.1 Peripheral Accessories Selection.....	15
5.2 Braking Resistor.....	16
5.3 Technical Data	17
Chapter 6 Keypad	19
Chapter 7 Troubleshooting.....	21
Chapter 8 Parameter	25

Chapter 1 Safety Information

Safety Definition

Pay attention to contents with following marks in the user manual or on the product.

 Danger
Danger: A Danger contains information which is critical for avoiding safety hazard.
 Warning
Warning: A Warning contains information which is essential for avoiding a risk of damage to products or other equipments..
<u>Note</u>
Note: A Note contains information which helps to ensure correct operation of the product.

Professional Staff

Only qualified electrical engineer can perform electrical installation.

Only professional staff that received special training and authorized can carry out maintenances.

Chapter 2 Product Information

2.1 Nameplate

Nameplate Label

Name plate label is pasted on right side of the product. Its contents are shown in the following figure.

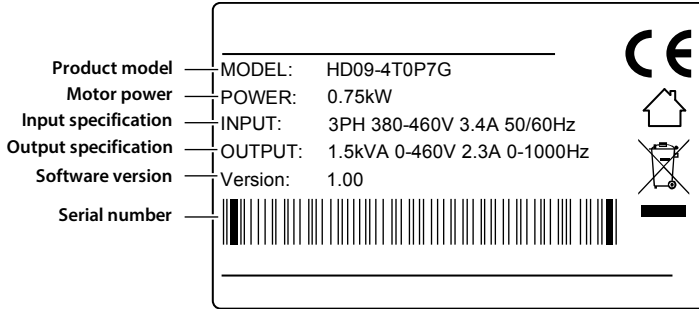

Power Label

Power label is below the keypad for recognizing the products easily and quickly.

Power label includes motor power and supply voltage. See 2.2 Rated Value, page 4.

Its contents are shown in the following figure.

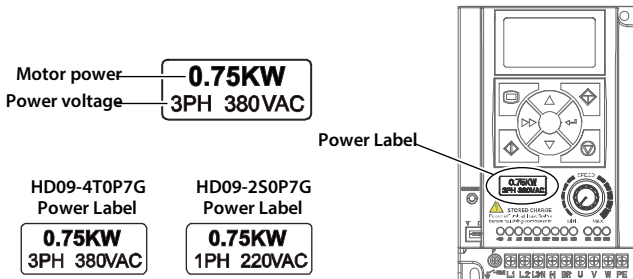

2.2 Rated Value

Single-phase: 200 - 240V, 50/60Hz

Size	Model	Motor power (kW)	Rated input current (A)	Rated volume (kVA)	Rated output current (A)
Size A	HD09-2S0P2G	0.25	4.3	0.6	1.7
Size A	HD09-2S0P4G	0.4	5.8	1.0	2.5
Size A	HD09-2S0P7G	0.75	10.5	1.5	4.0
Size A	HD09-2S1P5G	1.5	18.5	2.8	7.5
Size A	HD09-2S2P2G	2.2	24.1	3.8	10.0

Three-phase: 380 - 460V, 50/60Hz

Size	Model	Motor power (kW)	Rated input current (A)	Rated volume (kVA)	Rated output current (A)
Size A	HD09-4T0P4G	0.4	1.8	1.0	1.4
Size A	HD09-4T0P7G	0.75	3.4	1.5	2.3
Size A	HD09-4T1P5G	1.5	5.2	2.5	3.8
Size A	HD09-4T2P2G	2.2	7.3	3.4	5.1
Size B	HD09-4T4P0G	4.0	11.9	5.9	9.0
Size B	HD09-4T5P5G	5.5	15.0	8.5	13.0

Chapter 3 Machelical Installation

 <p>Danger</p>	<ul style="list-style-type: none"> • After opening the package, if damage or incompleteness is found, please do not install it and contact our distributor or us for solutions. • When conveying the inverter, please employ suitable tools according to its weight. Please avoid scratch to the product. Be careful: rollover and drop may cause hurt. • Avoid scaps of the drill slip into the inverter during installation. • For inverter with more than 2 year's storage, please use regulator to power it slowly.
--	---

3.1 Dimension and Weight

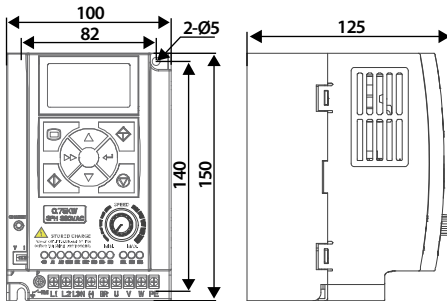

Size A:

Dimension: 100 × 150 × 125 mm

Mounting dimension: 82 × 140 mm

Mounting aperture: 5 mm

G.W.: 1.5 kg

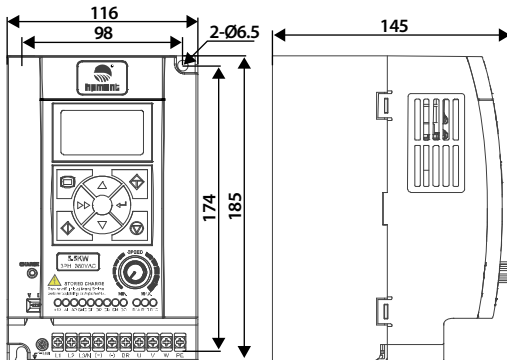

Size B:

Dimension: 116 × 185 × 145 mm

Mounting dimension: 98 × 174 mm

Mounting aperture: 6.5 mm

G.W.: 2.7 kg

3.2 Requirement for the Installation Site

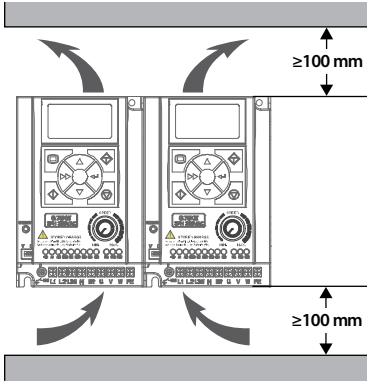

Ensure the installation site meets the following requirements:

- Do not install at the direct sunlight, moisture, water droplet location;
- Do not install at the flammability, explosive, corrosive gas and liquid locations;
- Do not install at the oily dust, fiber and metal powder location;
- Be vertical installation on fire-retardant material with a strong support;
- Install at where the humidity is less than 95%RH and non-condensing location;

- Install at where the vibration is 3.5m/s^2 in 2 - 9Hz, 10m/s^2 in 9 - 200Hz (IEC60721-3-3);
- This inverter meets IP20, and Pollution Degree level 2 (Dry, Non conducting dust pollution);
- Make sure adequate cooling space for the inverter so as to keep the ambient temperature between $-10 - 40^\circ\text{C}$, as shown in the figure at the left;

It needs derating use if the inverter operation temperature exceeds 40°C . The derating value of the output current of the inverter shall be 2% for each degree centigrade, Max. allowed temperature is 50°C .

3.3 Installation of Exterior Keypad

HD09 allows installing the optional keypad on the keypad of control door cabinet. The optional keypads are HD-LED-P and HD-LED-S.

3.3.1 Installation of HD-LED-P

HD-LED-P needs a mounting base HD-KMB for installation. Firstly install the base on the keypad of control door cabinet, and then install HD-LED-P inside the base.

The HD-KMB base and mounting aperture sizes are shown in the following figure (unit: mm).

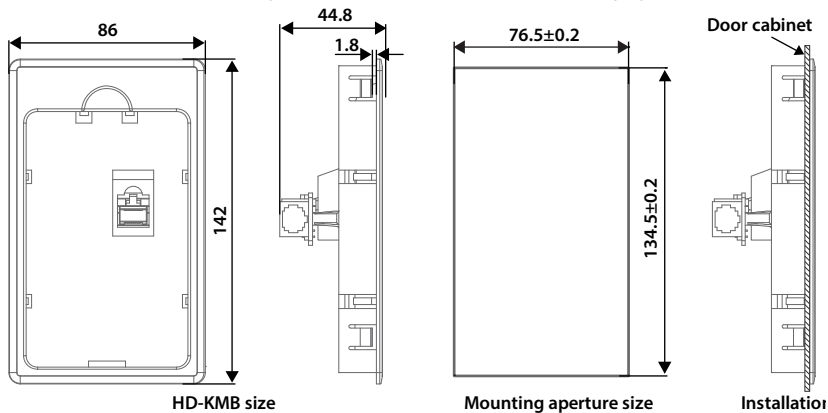

3.3.2 Installation of HD-LED-P-S

There are 2 installation methods selectable for HD-LED-P-S: install with screws or a mounting base.

Packing contents: mounting base, keypad, 2 pieces of M3x5 screws, 1 meter extension cable.

To Install with Screws

Install the HD-LED-P-5 on the keypad of control door cabinet with screws.

Dimension and mounting aperture sizes are shown in the following figure (unit: mm).

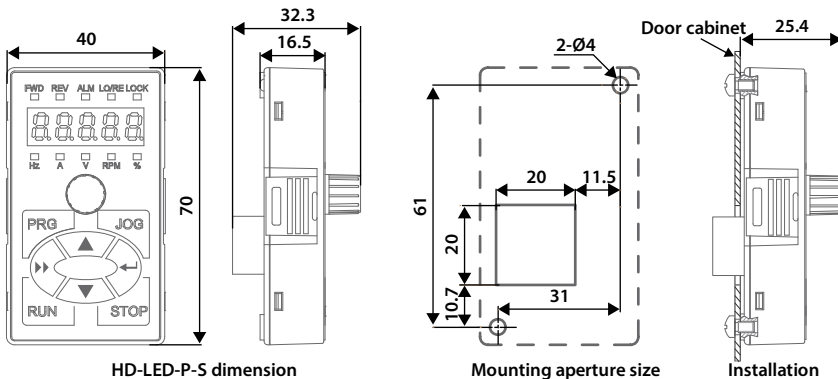

To Install with a Mounting Base

Firstly install the mounting base HD-KMB-S on the keypad of control door cabinet, and then install HD-LED-S inside the base.

The HD-KMB-S base and mounting aperture sizes are shown in the following figure (unit: mm).

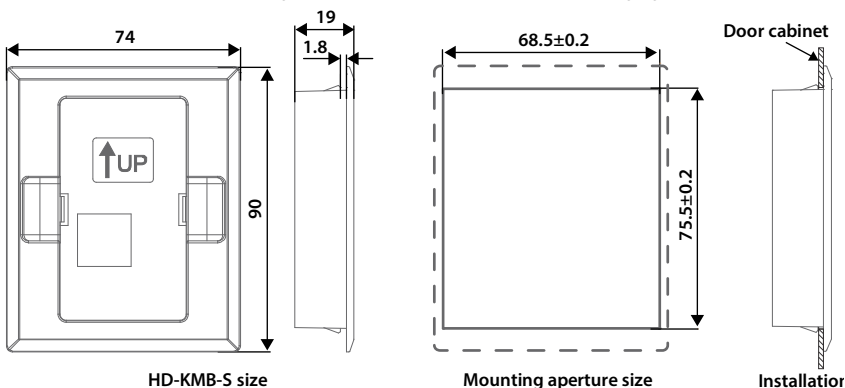

Chapter 4 Electrical Installation

 Danger	<ul style="list-style-type: none"> • Only qualified electrical engineer can perform wiring job. • Only when the power supply switch is completely off can you do the wiring job. • Check that the operation is effective and reliable after connecting to the emergency stop terminal of external power supply. • You must wrap the bare metal part of the power terminal with insulating tape. • Do not touch the wire terminals of the inverter when it is live.
--	---

Ensure the power supply is completely off

Only when the power supply switch is completely off can you do the wiring job.

Steps:

First, disconnect the power supply of the inverter.

Second, wait till the internal power supply indicator goes out (its position shown in the following figure) or wait until 5 minutes later.

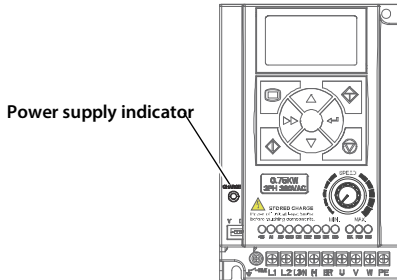

4.1 Power Terminals and Connection

Power Terminal Description

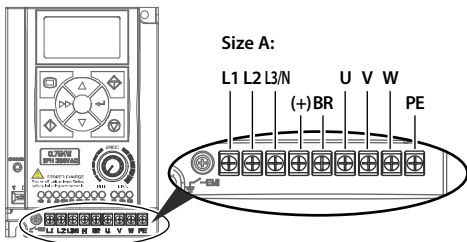

Terminal	Description
L1, L2, L3/N	Three-phase AC power input terminals
L1, L3/N	One-phase AC power input terminals
U, V, W	Output terminals, connect to AC motor
(+), BR	Braking resistor connection terminals
PE	Ground terminal, connect to the ground

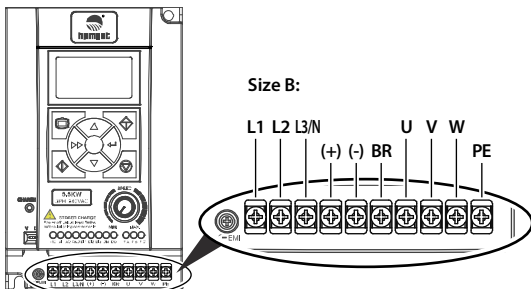

Terminal	Description
L1, L2, L3/N	Three-phase AC power input terminals
L1, L3/N	One-phase AC power input terminals
U, V, W	Output terminals, connect to AC motor
(+), BR	Braking resistor connection terminals
(+), (-)	DC supply input terminals
PE	Ground terminal, connect to the ground

Power Terminal Connection

Power Terminal Wiring is as shown in following figure.

For selection of contactor, MCBB, power supply cable, motor cable, ground cable and braking resistor, please refer to section 5.1.1 Wiring Specifications of Input and Output, page 15.

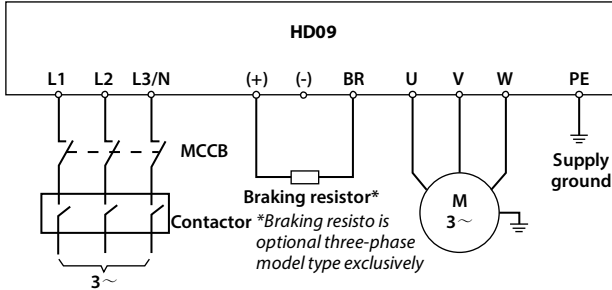

4.2 Control Terminals and Connection

Control Terminals Description

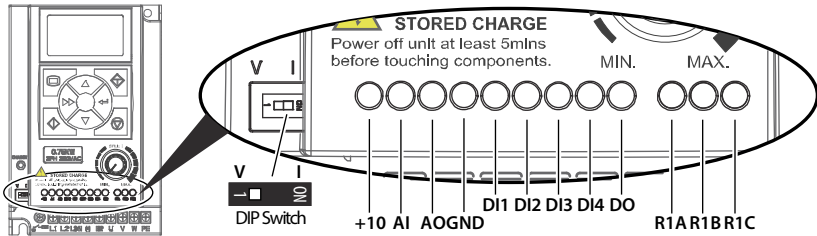

Terminal	Description	
+10	External power	Max. output current 100mA
AI	Analogue input	The DIP switch decides the voltage input or current input <ul style="list-style-type: none"> Voltage 0 - 10V, impedance 32kΩ (Factory setting) Current 0 - 20mA, impedance 500Ω
	Digital input (DI function)	When AI is used as DI, switch signals above 6V can be received <ul style="list-style-type: none"> Function F15.44 is the same with DI1 - DI3 (F15.00 - F15.02)
AO	Analogue output	Voltage 0 - 10V
GND	Power ground	Analogue and digital site, 0V
DI1, DI2, DI3	Digital input	Effective with GND short circuit

Terminal		Description
D14	Digital input	Effective with GND short circuit or High frequency input (F15.03 set as No. 53 function) • Max. frequency 50.0kHz (F16.17 setting)
DO	Digital output	Open collector output • External voltage 10 - 30VDC, max. current 50mA or High frequency input (F15.19 set as No. 38 function) • Max. frequency 50.0kHz (F16.26 setting)
R1A, R1B, R1C	Relay output	• Contact rating: 250VAC / 3A or 30VDC / 1A • R1B, R1C: normally closed; R1A, R1C: normally open

Note:

Limit the current within 3A if the relay terminal is to connect to AC 220V voltage signal.

Control Terminals Connection

The following figure shows wire connection of control terminal (factory setting).

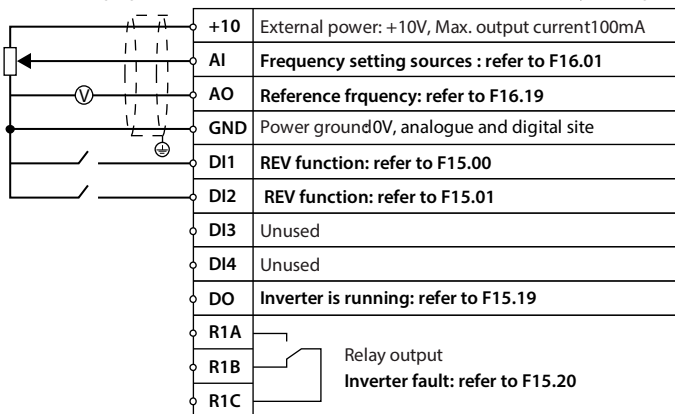

Analogue Input Connection

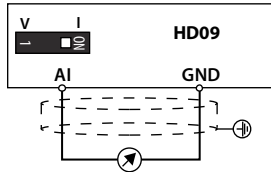
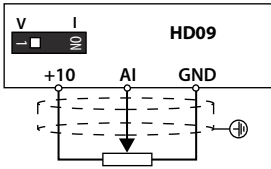

Digital Input Connection

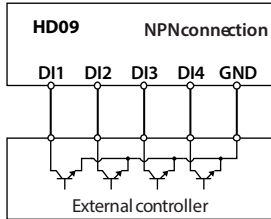
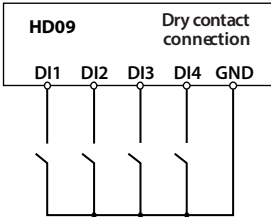

Digital Output Connection

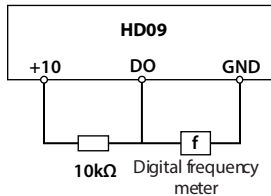
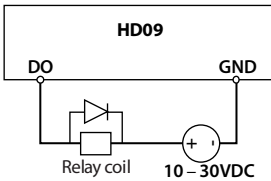

4.3 External Keypad or Upper Computer

The RJ45 terminal can connect the optional keypad or upper computer, as shown in the following figure.

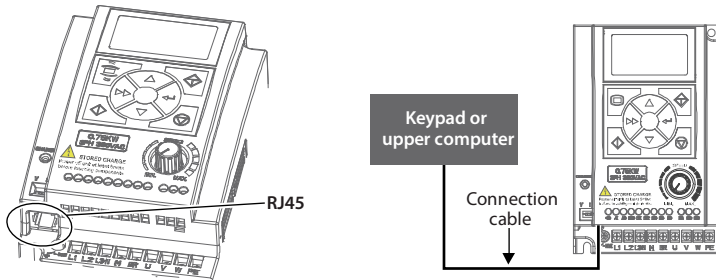

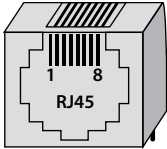
RJ45		Pin	Definition
		1, 3	+5V
		2	485+
		4, 5, 6	GND
		7	485-
8	Unused		
Keypad	Can connect the optional keypad to realize keypad control • Refer to Chapter 6 Keypad, page 19		
Upper Computer	Can connect the upper computer to realize communication control • The upper computer includes PLC, touch screen, PC, etc.		
Connection Cable	<ul style="list-style-type: none"> • 1m connection cable [HD-CAB-1M] • 2m connection cable [HD-CAB-2M] • 3m connection cable [HD-CAB-3M] • 6m connection cable [HD-CAB-6M] 		

Chapter 5 Technical Data

5.1 Peripheral Accessories Selection

5.1.1 Wiring Specifications of Input and Output

The AC supply to the drive must be installed with suitable protection against overload and short-circuits, i.e. MCCB (molded case circuit breaker) or equivalent device.

The recommended specification of MCCB, contactor & cables were shown as following tables.

The size of earth wire should not be smaller than the requirement in 4.3.5.4 of IEC61800-5-1.

Size	Model	MCCB (A)	Contactor (A)	Power Cable (mm ²)	Motor Cable (mm ²)	Ground Cable (mm ²)
Size A	HD09-2S0P2G	16	10	0.5	0.2	2.5
Size A	HD09-2S0P4G	16	10	0.75	0.5	2.5
Size A	HD09-2S0P7G	16	10	2.5	0.5	2.5
Size A	HD09-2S1P5G	20	16	6.0	1.5	6.0
Size A	HD09-2S2P2G	32	20	6.0	2.5	6.0
Size A	HD09-4T0P4G	10	10	0.5	0.2	2.5
Size A	HD09-4T0P7G	10	10	0.5	0.5	2.5
Size A	HD09-4T1P5G	16	10	1.0	0.5	2.5
Size A	HD09-4T2P2G	16	10	1.5	0.75	2.5
Size B	HD09-4T4P0G	25	16	2.5	2.5	2.5
Size B	HD09-4T5P5G	32	25	4.0	4.0	4.0

Note:

- Please select braking resistor based on the above table.
Bigger resistor can protect the braking system in fault condition, but oversized resistor may bring a capacity decrease, lead to over voltage protection.
- The braking resistor should be mounted in a ventilated metal housing to prevent inadvertent contact during it works, for the temperature is high.

5.1.2 Power Terminal Lug

The wiring lugs of the power terminals (round bare terminals) can be selected according to the terminal wiring specifications, screw size, and the maximum outside diameter of the wiring lugs.

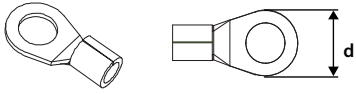
	Size	Size A	Size B
	Screw size	M3	M3.5
	Tightening torque (N. M)	0.6 - 0.8	0.8 - 1.2
	Max. outer diameter of lug d (mm)	6.1	7

5.2 Braking Resistor

Model	Resistance Value (Ω)	Resistance Power (W)
HD09-4T0P4G	300 - 400	80
HD09-4T0P7G	250 - 350	100
HD09-4T1P5G	200 - 300	200
HD09-4T2P2G	150 - 250	250
HD09-4T4P0G	100 - 150	300
HD09-4T5P5G	80 - 100	500

Note:

Braking unit is built in three-phase model type exclusively.







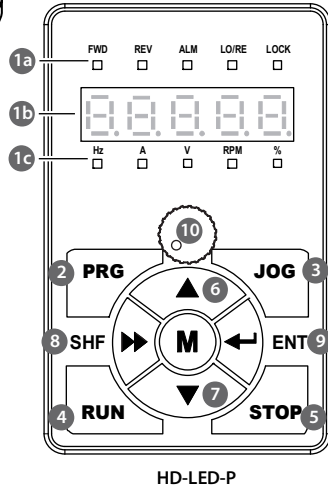
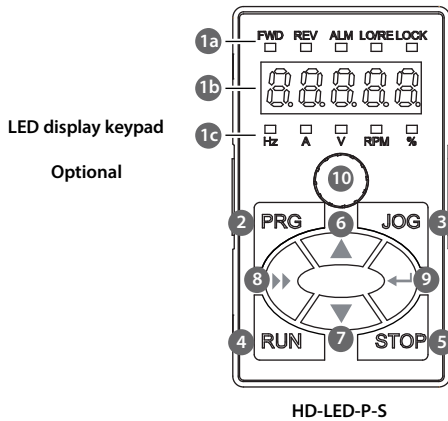
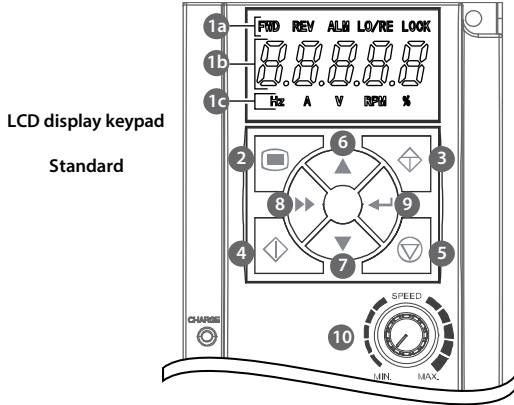

5.3 Technical Data

Electrical	
Inout voltage	HD09-2S ■ P ■ G: single-phase 200 - 240V HD09-4T ■ P ■ G: three-phase 380 - 460V Fluctuating within $\pm 10\%$, imbalance rate < 3%
Input frequency	50/60Hz $\pm 5\%$
Output voltage	0 - input voltage
Output frequency	0 - 1000Hz
Specification	
Control mode	V/f
Maximum current	150% rated output current 2 minutes; 180% rated output current 10 seconds
Speed resolution	Digital setting: 0.1Hz; Analogue setting: 0.1% \times maximum frequency
Wave frequency	Default setting: 4kHz; setting range: 1 - 16kHz; 4 - 16kHz: The derating value of wave frequency shall be 2% for each more than 1kHz
Environment	
Operation temperature	-10 - +40 °C, no derating; 40 - 50 °C, the derating value of the output current shall be 2% for each more than 1 °C
Storage temperature	-40 - +70 °C
Location for use	Indoor, preventing from direct sunlight, no dust, corrosive, flammable gases, oil mist, water vapor, dripping or salt etc.
Altitude	Less than 1000m, no derating; otherwise should be derating use
Humidity	Less than 95%RH, non-condensing
Vibration Resistance	It is 3.5m/s ² in 2 - 9Hz, it is 10m/s ² (IEC60721-3-3) in 9 - 200Hz
Protection level	IP20
Pollution degree	Level 2 (Dry, Non conducting dust pollution)
Accessories	
Keypad	HD-LED-P: LED keypad with potentiometer, matched with HD-KMB mounting base HD-LED-P-S: small size keypad, matched with HD-KMB-S mounting base
Connection cable	1m / 2m / 3m / 6m connection cable [HD-CAB-1M / 2M / 3M / 6M]

Chapter 6 Keypad

HD09 can either installed with LCD display keypad (standard), or LED display keypad (optional).



No.	Description
1	<p>The standard keypad contains LCD display, while the optional keypad contains LED nixie tube display.</p> <ul style="list-style-type: none"> • Three status: lighting, flashing and lightless. • Do not remove the standard LCD keypad. <p>a. Status indicator: indicating current status.</p> <ul style="list-style-type: none"> • FWD (Forward status): Motor is forward running (standard LCD) / lighting (optional LED) • REV (Reverse status): Motor is reverse running (standard LCD) / lighting (optional LED) • ALM (Alarm status): Motor is faulty (standard LCD) / lighting (optional LED) • LO/RE(Local/Remote status): Inverter is in terminal or communication control mode (standard LCD) / lighting (optional LED) • LOCK (Password locked status): User password lock of the inverter is avail (standard LCD) / lighting (optional LED) <p>b. Display area: Normal: displays parameter. Faulty: displays error code when the inverter is faulty.</p> <ul style="list-style-type: none"> • If a value is flashing, it mean that the value is revisable. <p>c. Unit indicator: Display unit of the current value.</p> <ul style="list-style-type: none"> • Include: Hz (frequency), A (current), V (voltage), RPM (rotate speed), % (percentage)
2	 PRG Program/Exit button: Entry or programming button
3	 JOG Jog button: In the keypad control, jog start the inverter
4	 RUN Run button: In the keypad control, press this button to run the inverter
5	 STOP Stop/Reset button: In the keypad control, to stop the inverter and reset the fault
6	 Increment button: In selecting parameter status, press it to increase the value of parameter; In setting parameter status, press it to increase the setting value.
7	 Decrement button: In selecting parameter status, press it to decrease the value of parameter; In setting parameter status, press it to decrease the setting value.
8	 SHE shift button: In selecting pr setting parameter status, shift 1 bit.
9	 ENT enter/confirm button: Enter lower menu; In setting parameter status, confirm and save the data.
10	Potentiometer: In setting parameter status, anti-clockwise means decrease, while clockwise means increase.

Chapter 7 Troubleshooting

HD09 series inverter has inbuilt protective and warning self-diagnostic functions. If a fault occurs, the fault code will be displayed on the display keypad. At the same time, fault relay acts, accordingly the inverter stops output and the motor coasts to stop.

When fault or alarm occurs, please record the fault details and take proper actions according to the below table. If you need some technical help, please contact to the suppliers or directly call Shenzhen Hpmont Technology Co., Ltd..

After the fault is eliminated, please reset the inverter by any of the following methods:

1. Display keypad. Press  (standard) / **STOP** (optional).
2. External reset terminal (multi-function terminal set as No. 46 function).
3. Communication.
4. Switching on the inverter after switching off.

Fault		Fault reasons	Counter-measures
-Lu-	DC bus undervoltage	<ul style="list-style-type: none"> At the begining of powering on and at the end of powering off Input voltage is too low Improper wiring leads to undervoltage of hardware 	<ul style="list-style-type: none"> It is normal status of powering on and powering off Please check input power voltage Please check wiring and wire the inverter properly
E0001	Inverter acceleration overcurrent	<ul style="list-style-type: none"> Improper connection between inverter and motor Improper motor parameters The rating of the used inverter is too small Acceleration/deceleration time is too short 	<ul style="list-style-type: none"> Connect the inverter and motor properly Please set correct motor parameters (F08.00 - F08.03) Select inverter with higher rating Please set proper acceleration time and deceleration time (F03.01, F03.02)
E0002	Inverter deceleration overcurrent		
E0003	Inverter constant speed overcurrent		
E0004	DC bus acceleration over voltage	<ul style="list-style-type: none"> Input voltage is too high Deceleartion time is too short Improper wiring leads to overvoltage of hardware Improper selection of the braking devices 	<ul style="list-style-type: none"> Please check power input Please set a proper value for deceleration time (F03.02) Please check wiring and wire the inverter properly Select according to the recommended braking devices of section 5.2 Braking Resistor, page 16
E0005	DC bus deceleration over voltage		
E0006	DC bus constant speed over voltage		

Fault		Fault reasons	Counter-measures
E0007	Stall overvoltage	<ul style="list-style-type: none"> Bus voltage is too high The setting of stall overvoltage is too low 	<ul style="list-style-type: none"> Please check power input or the function of brake Set the value of stall overvoltage properly (F19.19)
E0008	Fault of power module	<ul style="list-style-type: none"> Short circuit between phases output Short circuit to the ground Output current is too high Power module is damaged 	<ul style="list-style-type: none"> Please check the connection and connect the wire properly Please check the connection and connect the wire properly Please check the connection and mechanism Please contact the supplier for repairing
E0009	Heatsink overheat	<ul style="list-style-type: none"> Ambient temperature is too high Inverter external ventilation is not good Fan fault Fault occurs to temperature detection circuit 	<ul style="list-style-type: none"> Please use inverter with higher power capacity Improve the ventilation around the inverter Replace the cooling fan Please seek technical support
E0011	CPU fault	<ul style="list-style-type: none"> CPU abnormal 	<ul style="list-style-type: none"> Please detect at power on after completely power outage Please seek technical support
E0012	Parameters auto-tuning fault	<ul style="list-style-type: none"> Parameter auto-tuning is time out 	<ul style="list-style-type: none"> Please check the motor's connection Input the correct motor parameters (F08.01 - F08.03) Please seek technical support
E0013	Contactors is not actuated	<ul style="list-style-type: none"> Contactors fault Fault of control circuit 	<ul style="list-style-type: none"> Replace the contactors Please seek technical support
E0014	Fault of current detection circuit	<ul style="list-style-type: none"> Current detection circuit is damaged 	<ul style="list-style-type: none"> Please contact the supplier for repairing
E0016	Fault of output phase	<ul style="list-style-type: none"> Output phase disconnection or loss Heavy imbalance of inverter's three-phase load 	<ul style="list-style-type: none"> Please check the connection between inverter and motor Please check the quality of motor
E0017	Inverter overload	<ul style="list-style-type: none"> Acceleration time is too short Improper setting of V/f curve or torque boost leads to over current Mains supply voltage is too low Motor load is too high 	<ul style="list-style-type: none"> Adjust acceleration time (F03.01) Adjust V/f curve (F09.01 - F09.06) or torque boost (F09.07, F09.08) Please check mains supply voltage Please use inverter with proper power rating

Fault		Fault reasons	Counter-measures
E0019	Motor overload	<ul style="list-style-type: none"> • Improper setting of V/f curve • Mains supply voltage is too low • Normal motor runs for a long time with heavy load at low speed • Motor runs with blocked torque or load is too heavy 	<ul style="list-style-type: none"> • Adjust the setting of V/f curve (F09.01 - F09.06) • Check the power input • Please use special motor • Please check the load and mechanical transmission devices
E0021	Access fault of Control board EEPROM	<ul style="list-style-type: none"> • Memory circuit fault of control board EEPROM 	<ul style="list-style-type: none"> • Please contact the supplier for repairing
E0024	Fault of external equipment	<ul style="list-style-type: none"> • Fault terminal of external equipment operates 	<ul style="list-style-type: none"> • Please check external equipment
E0028	SCI communication time-out	<ul style="list-style-type: none"> • Connection fault of Communication cable • Disconnected or not well connected 	<ul style="list-style-type: none"> • Please check the connection
E0029	SCI communication error	<ul style="list-style-type: none"> • Connection fault of Communication cable • Disconnected or not well connected • Communication setting error • Communication data error 	<ul style="list-style-type: none"> • Please check the connection • Please check the connection • Please correctly set the communication format (F17.00), and the baud rate (F17.01)

Note:

If E0028 or E0029 are displayed on the keypad, there is no need to stop the inverter.

Chapter 8 Parameter

Attributes are changed:

“X”: It denotes that the setting of this parameter cannot be modified when the inverter is in run status.

“O”: It denotes that the setting of this parameter can be modified when the inverter is in run status.

“*”: It denotes that the value of this parameter is the actual value which cannot be modified.

Ref. Code	Function	Setting Range	Default	Unit	Attribute	Setting
F00: Basic Parameter						
F00.06	Inverter max. output frequency	50.0 - 1000.0Hz	50.0Hz	0.1Hz	×	
F00.08	Upper limit of operation frequency	0.0 - F00.06	50.0Hz	0.1Hz	×	
F00.09	Lower limit of operation frequency	0.0 - F00.08	0.0Hz	0.1Hz	×	
F00.10	Frequency setting sources selection	0: Keypad digital setting 1: Terminal digital setting 2: SCI communication setting 3: AI analogue setting 4: Terminal pulse setting	0	1	×	
F00.11	Command setting source selection	0: Keypad running source 1: Terminal running source 2: SCI communication running source	0	1	×	
F00.13	Starting frequency digital setting	0.0 - F00.08	50.0Hz	0.1Hz	○	
F00.14	UP/DOWN digital setting control	Units: Frequency setting save selection at power outage 0: Not save in power off 1: Save in power off Tens: Frequency setting control selection at stop 0: Set frequency keeping in stop 1: Recovery frequency to F00.13 in stop Hundreds: Communication setting frequency storage selection	1001	1	×	

Ref. Code	Function	Setting Range	Default	Unit	Attribute	Setting
		0: Not save in power off 1: Save in power off Thousands: Switch the frequency channel to the analogue selection 0: Not save 1: Save				
F00.15	Jog operation frequency digital setting	0.0 – up limitation (F00.08)	5.0Hz	0.1Hz	○	
F00.17	Running direction selection	0: Same direction 1: Reserved direction	0	1	×	
F00.19	Dead time of direction switch	0.0 - 3600.0s	0.0s	0.1s	×	
F00.20	Keypad enable	Unit: Button enable 0: Enable 1: Disable Ten: Potentiometer enable 0: Potentiometer priority for keypad 1: Potentiometer with keypad 2: Potentiometer with external keypad	00	1	○	
F00.21	Sleep function enable	0: Disable 1: Enable 1 2: Enable 2	0	1	×	
F00.22	Dormant wake time	0.0 - 360.0s	0.0s	0.1s	×	
F00.24	Sleep delay	0.0 - 3600.0s	0.0s	0.1s	×	
F00.25	Sleep frequency	0.0Hz - F00.08	0.5Hz	0.1Hz	○	
F01: Protection of Parameters						
F01.00	User's password	00000 - 65535	00000	1	○	
F01.01	Menu mode selection	0: Full menu mode 1: Checking menu mode	0	1	○	
F01.02	Function code parameter initialization (parameter download)	0: No operation 1: Restore to factory settings 2/3: keypad stored parameter 1/2 iscopied to control board and update current function value 4: Clear fault information	0	1	×	
F01.03	Copy parameter to keypad	0: No operation	0	1	○	

Ref. Code	Function	Setting Range	Default	Unit	Attribute	Setting
	(parameter uploading)	1/2: Current function values are copied to keypad stored parameter 1/2				
F02: Run / Stop Control Parameters						
F02.02	Start DWELL frequency setting	0.0 - F00.08	0.0Hz	0.1Hz	×	
F02.03	Retention time of starting DWELL frequency	0.00 - 10.00s	0.00s	0.01s	×	
F02.04	DC braking current setting	0 - 100%	50%	1%	×	
F02.05	DC braking time at start	0.00 - 60.00s	0.00s	0.01s	×	
F02.13	Stop mode selection	1: Coast to stop 2: Decelerate to stop	2	1	×	
F02.14	DWELL frequency setting at stop	0.0 - F00.08	0.0Hz	0.1Hz	×	
F02.15	Retention time of DWELL frequency at stop	0.00 - 10.00s	0.00s	0.01s	×	
F02.16	DC braking initial frequency at stop	0.0 - 50.0Hz	0.5Hz	0.1Hz	×	
F02.18	DC braking time at stop	0.00 - 60.00s	0.00s	0.01s	×	
F03: Acceleration/Deceleration Parameters						
F03.01	Acceleration time 1	0.01 - 600.00s	10.00s	0.01s	○	
F03.02	Deceleration time 1	0.01 - 600.00s	10.00s	0.01s	○	
F03.03	Acceleration time 2	0.01 - 600.00s	10.00s	0.01s	○	
F03.04	Deceleration time 2	0.01 - 600.00s	10.00s	0.01s	○	
F03.05	Acceleration time 3	0.01 - 600.00s	10.00s	0.01s	○	
F03.06	Deceleration time 3	0.01 - 600.00s	10.00s	0.01s	○	
F03.07	Acceleration time 4	0.01 - 600.00s	10.00s	0.01s	○	
F03.08	Deceleration time 4	0.01 - 600.00s	10.00s	0.01s	○	
F03.09	Ace. time 2 and 1 switch frequency	0.0 - up limitation	0.0Hz	0.0Hz	×	
F03.10	Dec. time 2 and 1 switch frequency	0.0 - up limitation	0.0Hz	0.0Hz	×	
F03.15	Spot Ace. time	0.01 - 600.00s	6.00s	0.01s	○	
F03.16	Spot Dec. time	0.01 - 600.00s	6.00s	0.01s	○	
F04: Process PID Control						
F04.00	Process PID control selection	0: PID control is disabled 1: PID control is enabled	0	1	×	

Ref. Code	Function	Setting Range	Default	Unit	Attribute	Setting
F04.02	Feedback source selection	0: AI analogue feedback 1: Terminal pulse feedback	0	1	×	
F04.03	Setting digital reference	0.0 - 100.0%	0.0%	0.1%	○	
F04.04	Proportional gain (P)	0.00 - 10.00	2.00	0.01	○	
F04.05	Integral time (I)	0.01 - 10.00s	1.00s	0.01s	○	
F04.07	Differential time (D)	0.00 - 10.00s	0.00s	0.01s	○	
F04.08	Differential amplitude limit value	0.0 - F00.08	20.0Hz	0.1Hz	○	
F04.09	Sampling cycle (T)	0.01 - 50.00s	0.10s	0.01s	○	
F04.10	Bias limit	0.0 - 20.0%	2.0%	0.1%	○	
F04.16	Integral regulation selection	0: Stop integral regulation when the frequency reaches the upper or lower limit 1: Continue the integral regulation when the frequency reaches the upper or lower limit	0	1	×	
F04.17	PID output filter time	0.01 - 10.00s	0.05s	0.01s	○	
F04.18	PID output reverse selection	0: PID regulation disable reverse (When PID output is negative, 0 is the limit) 1: PID regulation enable reverse	0	1	×	
F04.19	PID output reverse frequency's upper limit	0.0 - F00.08	50.0Hz	0.1Hz	×	
F05: External Reference Curve Parameters						
F05.01	Minimum reference of line	0.0% - F05.03	0.0%	0.1%	○	
F05.02	Minimum reference corresponding value of line	0.0 - 100.0%	0.0%	0.1%	○	
F05.03	Maximum reference of line	F05.01 - 100.0%	100.0%	0.1%	○	
F05.04	Maximum reference corresponding value of line	0.0 - 100.0%	100.0%	0.1%	○	
F05.17	Skip frequency	F00.09 - F00.08	0.0Hz	0.1Hz	×	
F05.20	Range of skip frequency	0.0 - 30.0Hz	0.0Hz	0.1Hz	×	
F06: Multi-step Speed Parameters						
F06.00	Multi-step frequency Command 1	F00.09 - F00.08	5.0Hz	0.1Hz	○	

Ref. Code	Function	Setting Range	Default	Unit	Attribute	Setting
F06.01	Multi-step frequency Command 2	F00.09 - F00.08	5.0Hz	0.1Hz	○	
F06.02	Multi-step frequency Command 3	F00.09 - F00.08	5.0Hz	0.1Hz	○	
F06.03	Multi-step frequency Command 4	F00.09 - F00.08	5.0Hz	0.1Hz	○	
F06.04	Multi-step frequency Command 5	F00.09 - F00.08	5.0Hz	0.1Hz	○	
F06.05	Multi-step frequency Command 6	F00.09 - F00.08	5.0Hz	0.1Hz	○	
F06.06	Multi-step frequency Command 7	F00.09 - F00.08	5.0Hz	0.1Hz	○	
F08: Motor Parameters						
F08.00	Rated power of motor	0.2 - 5.5kW	Dependent on HD09	0.1kW	×	
F08.01	Rated voltage of motor	0V - inverter's rated voltage		1V	×	
F08.02	Rated current of motor	0.01 - 99.99A		0.01A	×	
F08.03	Rated frequency of motor	1 - 1000Hz	50Hz	1Hz	×	
F08.04	Rated Rpm of motor	1 - 2400rpm	Dependent on HD09	1rpm	×	
F08.06	Parameter auto-tuning of motor	0: Auto-tuning is disabled 1: Stationary auto-tuning	0	1	×	
F08.07	Stator resistance of motor	0.00 - 99.99Ω	Dependent on HD09	0.01Ω	×	
F09: V/f Control Parameters						
F09.01	V/f frequency value F3	F09.03 - 100.0% (F08.03)	100.0%	0.1%	×	
F09.02	V/f voltage value V3	F09.04 - 100.0% (F08.01)	100.0%	0.1%	×	
F09.03	V/f frequency value F2	F09.05 - F09.01 (F08.03)	0.0%	0.1%	×	
F09.04	V/f voltage value V2	F09.06 - F09.02 (F08.01)	0.0%	0.1%	×	
F09.05	V/f frequency value F1	0.0% - F09.03 (F08.03)	0.0%	0.1%	×	
F09.06	V/f voltage value V1	0.0% - F09.04 (F08.01)	0.0%	0.1%	×	
F09.07	Torque boost	0.0 - 30.0%	2.0%	0.1%	×	
F09.08	Cut-off point used for manual torque boost	0.0 - 50.0% (F08.03)	30.0%	0.1%	○	
F09.09	Motor transfer compensation gain	0.0 - 300.0%	0.0%	0.1%	○	

Ref. Code	Function	Setting Range	Default	Unit	Attribute	Setting
F09.10	Compensation filtering time for motor transfer	0.01 - 10.00s	0.10s	0.01s	○	
F09.11	Differential compensation for motor differential	0.0 - 250.0%	200.0%	0.1%	×	
F09.12	The time constant of the motor compensation	0.1 - 25.0s	2.0s	0.1s	○	
F09.14	AVR (automatic voltage regulation) function	0: No action 1: Keep acting 2: No action only in Dec.	1	1	○	
F09.15	Oscillation-suppression mode	0: Oscillation-suppression mode 1 1: Oscillation-suppression mode 2	0	1	○	
F09.16	Oscillation-suppression coefficient	0 - 200	50	1	○	
F15: Digital Input/Output Terminal Parameters						
F15.00	DI1 function	0: Unused 1: Inverter enabled 2,3: FWD / REV function 4: Three-wire operation mode 8: AI to be the frequency source 11: Terminal control mode to be the run command source	2	1	×	
F15.01	DI2 function	13 - 15: Multi-step frequency terminal 1 - 3 17: Frequency ramp (UP) 18: Frequency ramp (DN) 19: Clearing auxiliary frequency setting	3	1	×	
F15.02	DI3 function	20,21: Forward and reverse jog command control input (JOGF / JOGR) 26,27: Selection terminals in Ace. and Dec. time 1,2 41: Coast to stop (normally-open input)	0	1	×	
F15.03	DI4 function	42: Coast to stop (normally-closed input) 44: External fault signal (normally-open input) 45: External fault signal (normally-closed input) 46: External reset input (RST)	0	1	×	

Ref. Code	Function	Setting Range	Default	Unit	Attribute	Setting
F15.44	AI terminal (ADI function) selection	50: Clearing the counter to zero 51: Counter's triggering signal input 53: Pulse frequency input (only DI4 terminal is enabled) <i>ADI is valid when F15.44 is not as . as 0, only AI is valid.</i>	0	1	×	
F15.12	Acc / Dec rate of UP/DN terminal	0.0 - 99.9Hz/s	1.0Hz/s	0.1Hz/s	×	
F15.14	Terminal detecting filter number	0 - 10000	2	1	○	
F15.15	Terminal input positive and negative logic setting	Bit0 - Bit3 is corresponding to DI1 - DI4 Bit12 is corresponding to AI Bitx: Dly terminal input positive and negative logic 0: Positive logic 1: Negative logic	0	1	○	
F15.16	FWD / REV operation mode	0: Two-wire operation mode 1 1: Two-wire operation mode 2 2: Three-wire operation mode 1 3: Three-wire operation mode 2	0	1	×	
F15.19	DO function	0: Unused 2: Inverter is running (RUN) 3: Inverter is forward running 4: Inverter is reverse running 5: Inverter is DC braking 9: Frequency detection threshold (FDT) 11: Frequency arriving signal (FAR)	2	1	×	
F15.20	Relay function	20: Output data from SCI communication 21: Preset operating time out 23: Preset counting value reach 24: Indicating counting value reach 31: Inverter fault 38: High-frequency output (only DO)	31	1	×	
F15.27	FAR range	0.0 - 100.0Hz	2.5Hz	0.1Hz	○	
F15.31	FDT level	0.0 - F00.06	50.0Hz	0.1Hz	○	
F15.32	FDT lag	- F00.06 - F00.06	1.0Hz	0.1Hz	○	
F15.36	Preset operating time	0 - 65535h	0h	1h	○	

Ref. Code	Function	Setting Range	Default	Unit	Attribute	Setting
		0: Preset operating time is disabled				
F15.37	Preset counting value arriving	F15.38 - 9999	0	1	○	
F15.38	Specified counting value arriving	0 - F15.37	0	1	○	
F15.43	Terminal output delay	0.0 - 100.0s	0.0s	0.1s	×	
F16: Analogue I/O Terminal Parameters						
F16.00	Keypad with potentiometer function	0: Unused 2: Frequency setting source	0	1	×	
F16.01	AI function	3: Auxiliary frequency reference 5: Process PID feedback	2	1	×	
F16.05	AI bias	-100.0 - 100.0%	0.0%	0.1%	○	
F16.06	AI gain	0.00 - 10.00	1.00	0.01	○	
F16.07	AI input filtering time	0.01 - 10.00s	0.05s	0.01s	○	
F16.17	DI4 max. input pulse frequency	0.0 - 50.0kHz	10.0kHz	0.1kHz	○	
F16.18	DI4 input pulse filtering time	0 - 500ms	10ms	1ms	○	
F16.19	AO function	0: Unused 2: Reference frequency (0 - max. output frequency) 3: Motor speed (0 - max. output frequency corresponding to speed) 5: Output current (0 - twice motor's rated current)	2	1	○	
F16.21	DO function	11: Output voltage (0 - 1.2 times inverter's rated voltage) 12: Bus voltage (0 - 2.2 times inverter's rated voltage)	0	1	○	
F16.22	AO bias	-100.0 - 100.0%	0.0%	0.1%	○	
F16.23	AO gain	0.0 - 200.0%	100.0%	0.1%	○	
F16.26	DO max. output pulse frequency	0.1 - 50.0kHz	10.0kHz	0.1kHz	○	
F17: SCI Communication Parameters						
F17.00	Data format	0: 1-8-2 format, no parity, RTU 1: 1-8-1 format, even parity, RTU 2: 1-8-1 format, odd parity, RTU	0	1	×	
F17.01	Baud rate selection	0: 1200bps	3	1	×	

Ref. Code	Function	Setting Range	Default	Unit	Attribute	Setting
		1: 2400bps 2: 4800bps 3: 9600bps 4: 19200bps 5: 38400bps				
F17.02	Local address	0 - 247	2	1	×	
F17.03	Host PC response time	0 - 1000ms	1ms	1ms	×	
F17.04	Time threshold for detecting communication status	0.0 - 1000.0ms <i>0.0: Not detecting communication over time</i>	0.0s	0.1s	×	
F17.05	Detecting time at communication error	0.0 - 1000.0ms <i>0.0: Not detecting communication error</i>	0.0s	0.1s	×	
F17.09	Communication write function parameter of storage EEPROM method selection	Units: Communication write function parameter of storage EEPROM method selection (Except for F00.13 and F19.03) Tens: Communication write function parameter of storage EEPROM method selection for F00.13 and F19.03 0: Without storage EEPROM 1: Storage EEPROM	01	1	×	
F17.10	Detecting time when network communication over time	0.0 - 600.0s <i>0.0: Not detecting communication error</i>	0.0s	0.1s	×	
F18: Display Control Parameter						
F18.02	Running display parameter 1 setting	0: Reserved 1: Inverter rated current 3: Inverter status 4: Main setting frequency channel 5: Main setting frequency 7: Setting frequency 8: Given frequency (after Dec. and Ace.) 9: Output frequency 10: Setting RPM 11: Running rpm 13: Output voltage 14: Output current	8	1	○	

Ref. Code	Function	Setting Range	Default	Unit	Attribute	Setting
F18.08	Stop display parameter 1 setting	15: Torque given 16: Output torque 17: Output power 18: DC bus voltage 19: Keypad potentiometer input voltage 20: AI input voltage 21: AI input voltage (after handling) 28: DI4 terminal pulse input frequency 29: AOoutput 32: Heat sink temperature 33: Given line speed 34: Given line speed 42: External value 43: Input terminals statuses 44: Output terminals status 48: Total power time accumulates (hours) 49: Total running time accumulates (hours)	7	1	○	
F18.14	Frequency display gain	0.1 - 160.0	1.0	0.1	○	
F18.15	Max. line speed	0 - 65535	1000	1	○	
F18.16	Line speed display accuracy	0: Integer 1: A decimal 2: Two decimals 3: Three decimals	0	1	×	
F18.17	LCD Backlighting screen saver mode	0: Current mode 1: External signal input changed, cancel backlighting screen	0	1	○	
F19: Function-boost Parameters						
F19.07	Control selection of cooling fan	0: Auto stop mode 1: Immediate stop mode 2: The fan runs continuously when power on	0	1	×	
F19.08	Cooling fan controls delaying time	0.0 - 600.0s	30.0s	0.1s	×	
F19.12	Instantaneous loss of power and no stop function selection	0: Disable instantaneous loss and no stop 1: Enable instantaneous loss and no	0	1	×	

Ref. Code	Function	Setting Range	Default	Unit	Attribute	Setting
		stop				
F19.13	Instant stop function deceleration time	0.01 - 600.00s	5.00s	0.01s	○	
F19.14	Voltage rerise judgement time for Instantaneous loss of power and no downtime	0.00 - 10.00s	0.10s	0.01s	○	
F19.15	Voltage judgement for Instantaneous loss of power and no downtime	0 - 999V	220V inverter: 248V 380V inverter: 430V	1V	×	
F19.18	Protection of stall overvoltage	0: Disabled (with braking resistance) 1: Enabled	1	1	×	
F19.19	Stall overvoltage point	0 - 999V	Dependent on HD09	1V	×	
F19.20	Auto current limiting selection	0: Disabled 1: Enabled in Acc / Dec running process, but disabled in constant speed running process 2: Enabled both in Acc / Dec and in constant speed running process	1	1	×	
F19.21	Auto current limiting threshold	20.0 - 200.0%	150.0%	0.1%	×	
F19.22	Deceleration time at auto current limiting	0.00 - 600.00s	0.00s	0.01s	×	
F19.23	Enabled mode of terminal run command	0: Rise edge enabled mode 1: Level enabled mode	0	1	○	
F19.24	Action voltage of braking unit	630 - 750V	Dependent on HD09	1V	×	
F19.37	Frequency adjust range selection	Unit: Main frequency range 0: 0 - max. frequency 1: Negative maximum frequency to maximum frequency	100	1	○	

Ref. Code	Function	Setting Range	Default	Unit	Attribute	Setting
		Ten: Unused Hundreds: The range of synthetic frequencies 0: 0 - up limitation frequency 1: Negative upper limit frequency to upper limit frequency				
F19.39	Input voltage selection	Unit: 380V input voltage 0: 380 - 460V 1: 260 - 460V 2: 200 - 460V Ten: 220V input voltage selection 0: 200 - 240V 1: 140 - 240V	00	1	×	
F19.44	LCD Backlight display time	0.0 - 999.9min	5.0min	0.1min	○	
F20: Protection of Fault Parameters						
F20.00	Selection for overload prediction police check out	00000: Enbale overload protection 10000: Disbale overload protection	00000	1	○	
F20.10	Output phase loss detection reference	0 - 50%	20%	1%	×	
F20.11	Output phase loss detection time	0.00 - 20.00s	3.00s	0.01s	×	
F20.18	Auto reset times	0 - 100	0	1	×	
F20.19	Auto reset interval	2.0 - 20.0s/times	5.0 s/times	0.1 s/times	×	
F20.21	Type of third latest (the last) fault	-Lu-: DC bus undervoltage E0001: Acc overcurrent E0002: Dec overcurrent E0003: Costant overcurrent E0004: Acc overvoltage E0005: Dec overvoltage E0006: Constant overvoltage E0007: Stall overvoltage E0008: Fault of power module E0009: Heatsink overheat E0011: CPUfault E0012: Parameters auto-tuning fault E0013: Contactor is not actuated	0	1	*	

Ref. Code	Function	Setting Range	Default	Unit	Attribute	Setting
		E0014: Fault of current detection circuit E0016: Fault of output phase E0017: Inverter overload E0019: Motor overload E0021: Access fault of control board EEPROM E0024: Fault of external equipment E0028: SCI communication time-out E0029: SCI communication error				
F20.22	Setting frequency at the last fault	0.0 - 1000.0Hz	0.0Hz	0.1Hz	*	
F20.23	Running frequency at the last fault	0.0 - 1000.0Hz	0.0Hz	0.1Hz	*	
F20.24	Bus voltage at the last fault	0 - 999V	0V	1V	*	
F20.25	Output voltage at the last fault	0 - 999V	0V	1V	*	
F20.26	Output current at the last fault	0.00 - 99.99A	0.00A	0.01A	*	
F20.29	Interval of third latest fault	0.0 - 6553.5h	0.0h	0.1h	*	
F20.30	Type of second latest fault	0 - 99	0	1	*	
F20.31	Interval of second latest fault	0.0 - 6553.5h	0.0h	0.1h	*	
F20.32	Type of first latest fault	0 - 99	0	1	*	
F20.33	Interval of first latest fault	0.0 - 6553.5h	0.0h	0.1h	*	
F23: PWM Control Parameters						
F23.00	Set the carrier frequency	1 - 16kHz	4kHz	1kHz	x	