

MD380 Series

High-Performance AC Drive

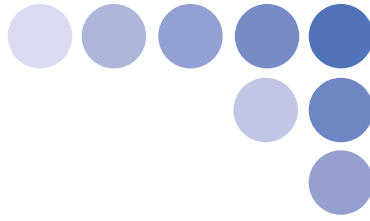

User Manual

V0.0

Data code: 19010180

Preface

Thank you for purchasing the MD380 series AC drive developed by Shenzhen Inovance Technology Co., Ltd.

The MD380 series AC drive is a general-purpose high-performance current vector control AC drive. It is an upgrade product based on MD320 and can implement the control of asynchronous motor and permanent magnet synchronous motor (PMSM). It increases the user programmable function, background monitoring software and communication bus function, and supports multi-kind PG cards. It is used to drive various automation production equipment involving textile, paper-making, wire drawing, machine tool, packing, food, fan and pump.

This manual describes the correct use of the MD380 series AC drive, including selection, parameter setting, commissioning, maintenance & inspection. Read and understand the manual before use and forward the manual to the end user.

Notes

- The drawings in the manual are sometimes shown without covers or protective guards. Remember to install the covers or protective guards as specified first, and then perform operations in accordance with the instructions.
- The drawings in the manual are shown for description only and may not match the product you purchased.
- The instructions are subject to change, without notice, due to product upgrade, specification modification as well as efforts to increase the accuracy and convenience of the manual.
- Contact our agents or customer service center if you have problems during the use.

Introduction

Compared with MD320, the MD380 series AC drive incorporates the following improvements:

1) Multiple voltage classes

It provides coverage of single-phase 220 V, three-phase 220 V, three-phase 380 V, three-phase 480 V, three-phase 690 V and three-phase 1,140 V.

2) Control of asynchronous motor and PMSM

It supports vector control of three-phase AC asynchronous motor and three-phase AC PMSM.

3) Diversified control modes

It supports three control modes, namely, sensorless flux vector control (SFVC), closed-loop vector control (CLVC) and V/F control.

4) Multiple communication protocols

It supports communication via Modbus-RTU, PROFIBUS-DP, CANlink and CANopen.

5) Multiple encoder types

It supports various encoders such as differential encoder, open-collector encoder, resolver and UVW encoder.

6) All-new SFVC algorithm

It introduces an all-new sensorless flux vector control (SFVC) algorithm that gives better low-speed stability, enhanced low-frequency loading capacity, and supports torque control.

7) User programmable function

The MD38PC1 programmable card enables you to write programs in ladder diagram. Its programming environment is compatible with that of the H1U series PLC.

8) Advanced background software

The background monitoring software helps to achieve functions of parameter upload & download and a real-time oscilloscope.

9) Other new functions

The newly added functions of the MD380 series AC drive are described as below:

Function	Description
Virtual I/O	It can implement various simple logic functions.
Motor overheat protection	The optional MD38IO1 extension card enables AI3 to receive the signal from the motor temperature sensor input (PT100, PT1000) thereby providing motor overheat protection.
Rapid current limit	It helps to avoid frequent occurrence of overcurrent faults of the AC drive.

Function	Description
Multi-motor switchover	Four motors can be switched over via four groups of motor parameters.
Restoring user parameters	It allows you to save or restore the parameters set by yourself.
Higher-accuracy AI/AO	The AI/AO accuracy can reach almost 20 mv via factory correction or on-site correction.
Customized parameter display	You can customize the parameters that need to be displayed.
Modified parameter display	You can view the modified parameters.
Operation selection at fault occurrence	You can select the reaction of the AC drive to a fault occurring, based on the actual need. The reactions are as below: <ul style="list-style-type: none"> • Coast to stop • Decelerate to stop • Continue to run You can also select the frequency at which the AC drive continues to run.
PID parameters switchover	Two groups of PID parameters can be switched over via terminals or can be automatically switched over according to deviation.
PID feedback loss detection	The PID feedback loss value can be set to realize PID protection.
DI/DO positive or negative logic	You can set the DI/DO positive or negative logic.
DI/DO response delay	You can set DI/DO response delay time.
Power dip ride through	It ensures that the AC drive continues to run for a short time when an instantaneous power failure or sudden voltage reduction occurs.
Timing operation	The AC drive supports timing operation for 6500 minutes at maximum.
User programmable function	The externally connected programmable card helps you to realize secondary development.
Load allocation	Load allocation can be implemented between two MD380 series AC drives through point-to-point communication.

Product Checking

Upon unpacking, check:

- Whether the nameplate model and AC drive ratings are consistent with your order. The box contains the AC drive, certificate of conformity, user manual and warranty card.
- Whether the AC drive is damaged during transportation. If you find any omission or damage, contact Inovance or your supplier immediately.

First-time Use

For the users who use this product for the first time, read the manual carefully. If in doubt concerning some functions or performances, contact the technical support personnel of Inovance to ensure correct use.

CE Mark

The CE mark on the MD380 declares that the AC drive complies with the European low voltage directive (LVD) and EMC directive.



The MD380 series AC drive complies with the following LVD and EMC directives and standards:

Directive	Directive Code	Standard
EMC Directive	2004/18/EC	EN 61800-3 EN 55011 EN 61000-6-2
LVD Directive	2006/95/EEC	EN 61800-5-1

The MD380 series AC drive complies with the requirements of standard IEC/EN 61800-3 on the condition of correct installation and use by following the instructions in chapter 7.

Contents

Preface	1
Introduction	2
Chapter 1 Safety Information and Precautions.....	10
1.1 Safety Information	10
1.2 General Precautions.....	12
Chapter 2 Product Information	18
2.1 Designation Rules and Nameplate of the MD380	18
2.2 Components of the MD380.....	18
2.3 Technical Specifications	20
2.4 Peripheral Electrical Devices and System Configuration	24
Chapter 3 Mechanical and Electrical Installation.....	30
3.1 Mechanical Installation	30
3.2 Electrical Installation.....	35
Chapter 4 Operation, Display and Application Examples.....	46
4.1 Operation Panel.....	46
4.2 Viewing and Modifying Function Codes	48
4.3 Structure of Function Codes.....	49
4.4 Quick View of Function Codes	50
4.5 Definition and Operation of the Multifunction Key (MF.K).....	52
4.6 Viewing Status Parameters	52
4.7 Starting or Stopping the AC Drive.....	54
4.8 Setting the Running Frequency	60
4.9 Setting and Auto-tuning of Motor Parameters	69
4.10 Use of DI Terminals	72
4.11 Use of DO Terminals.....	73
4.12 Use of AI Terminals.....	73
4.13 Use of AO Terminals.....	74
4.14 Use of the PG Terminal	75
4.15 Use of Serial Communication	75
4.16 Use of Multifunctional Extension Interfaces.....	76

4.17 Password Setting.....	77
4.18 Parameter Saving and Default Setting Restoring.....	77
Chapter 5 Function Code Table.....	80
5.1 Standard Function Parameters.....	80
5.2 Monitoring Parameters.....	133
Chapter 6 Description of Function Codes.....	136
Group F0: Basic Parameters.....	136
Group F1: Motor 1 Parameters.....	148
Group F2: Vector Control Parameters.....	152
Group F3: V/F Control Parameters.....	156
Group F4: Input Terminals.....	161
Group F5: Output Terminals.....	172
Group F6: Start/Stop Control.....	177
Group F7: Operation Panel and Display.....	183
Group F8: Auxiliary Functions.....	187
Group F9: Fault and Protection.....	198
Group FA: Process Control PID Function.....	207
Group FB: Swing Frequency, Fixed Length and Count.....	212
Group FC: Multi-Reference and Simple PLC Function.....	215
Group FD: User-defined Parameters.....	219
Group FE: User-Defined Function Codes.....	219
Group FP: User Password.....	220
Group A0: Torque Control and Restricting Parameters.....	222
Group A1: Virtual DI (VDI)/Virtual DO (VDO).....	224
Group A2 to A4: Motor 2 to Motor 4 Parameters.....	228
Group A5: Control Optimization Parameters.....	232
Group A6: AI Curve Setting.....	234
Group A7: User Programmable Function.....	236
Group A8: Point-point Communication.....	236
Group AC: AI/AO Correction.....	239
Group U0: Monitoring Parameters.....	240



Chapter 7 EMC.....	248
7.1 Definition of Terms.....	248
7.2 Introduction to EMC Standard	248
7.3 Selection of Peripheral EMC Devices.....	249
7.4 Shielded Cable	256
7.5 Solutions to Common EMC Interference Problems.....	258
Chapter 8 Selection and Dimensions	260
8.1 Electrical Specifications of the MD380	260
8.2 Physical Appearance and Overall Dimensions of the MD380	263
8.3 Recommended Cable Diameter and Installation Dimensions of Power Terminals.....	267
8.4 Selection of Peripheral Electrical Devices	276
8.5 Selection and Installation of External DC Reactor.....	278
8.6 Physical Dimensions of External Operation Panel	280
8.7 Selection of Braking Unit and Braking Resistor.....	280
Chapter 9 Maintenance and Troubleshooting.....	286
9.1 Routine Repair and Maintenance of the MD380	286
9.2 Warranty Agreement.....	287
9.3 Faults and Solutions	287
9.4 Common Faults and Solutions	292



Safety Information and Precautions





Chapter 1 Safety Information and Precautions







In this manual, the notices are graded based on the degree of danger:



-  **DANGER** indicates that failure to comply with the notice will result in severe personal injury or even death.
-  **WARNING** indicates that failure to comply with the notice will result in personal injury or property damage.

Read this manual carefully so that you have a thorough understanding. Installation, commissioning or maintenance may be performed in conjunction with this chapter. Invoiance will assume no liability or responsibility for any injury or loss caused by improper operation.

1.1 Safety Information

Use Stage	Safety Grade	Precautions
Before installation	 DANGER	<ul style="list-style-type: none"> • Do not install the equipment if you find water seepage, component missing or damage upon unpacking. • Do not install the equipment if the packing list does not conform to the product you received.
	 WARNING	<ul style="list-style-type: none"> • Handle the equipment with care during transportation to prevent damage to the equipment. • Do not use the equipment if any component is damaged or missing. Failure to comply will result in personal injury. • Do not touch the components with your hands. Failure to comply will result in static electricity damage.
During installation	 DANGER	<ul style="list-style-type: none"> • Install the equipment on incombustible objects such as metal, and keep it away from combustible materials. Failure to comply may result in a fire. • Do not loosen the fixed screws of the components, especially the screws with red mark.
	 WARNING	<ul style="list-style-type: none"> • Do not drop wire end or screw into the AC drive. Failure to comply will result in damage to the AC drive. • Install the AC drive in places free of vibration and direct sunlight. • When two AC drives are laid in the same cabinet, arrange the installation positions properly to ensure the cooling effect.

Use Stage	Safety Grade	Precautions
At wiring	 DANGER	<ul style="list-style-type: none"> Wiring must be performed only by qualified personnel under instructions described in this manual. Failure to comply may result in unexpected accidents. A circuit breaker must be used to isolate the power supply and the AC drive. Failure to comply may result in a fire. Ensure that the power supply is cut off before wiring. Failure to comply may result in electric shock. Tie the AC drive to ground properly by standard. Failure to comply may result in electric shock.
	 WARNING	<ul style="list-style-type: none"> Never connect the power cables to the output terminals (U, V, W) of the AC drive. Pay attention to the marks of the wiring terminals and ensure correct wiring. Failure to comply will result in damage to the AC drive. Never connect the braking resistor between the DC bus terminals (+) and (-). Failure to comply may result in a fire. Use wire sizes recommended in the manual. Failure to comply may result in accidents. Use a shielded cable for the encoder, and ensure that the shielding layer is reliably grounded.
Before power-on	 DANGER	<ul style="list-style-type: none"> Check that the following requirements are met: <ul style="list-style-type: none"> The voltage class of the power supply is consistent with the rated voltage class of the AC drive. The input terminals (R, S, T) and output terminals (U, V, W) are properly connected. No short-circuit exists in the peripheral circuit. The wiring is secured. Failure to comply will result in damage to the AC drive Do not perform the voltage resistance test on any part of the AC drive because such test has been done in the factory. Failure to comply will result in accidents.
	 WARNING	<ul style="list-style-type: none"> Cover the AC drive properly before power-on to prevent electric shock. All peripheral devices must be connected properly under the instructions described in this manual. Failure to comply will result in accidents
After power-on	 DANGER	<ul style="list-style-type: none"> Do not open the AC drive's cover after power-on. Failure to comply may result in electric shock. Do not touch any I/O terminal of the AC drive. Failure to comply may result in electric shock.
	 WARNING	<ul style="list-style-type: none"> Do not touch the rotating part of the motor during the motor auto-tuning or running. Failure to comply will result in accidents. Do not change the default settings of the AC drive. Failure to comply will result in damage to the AC drive.

Use Stage	Safety Grade	Precautions
During operation	 DANGER	<ul style="list-style-type: none"> Do not touch the fan or the discharging resistor to check the temperature. Failure to comply will result in personal burnt. Signal detection must be performed only by qualified personnel during operation. Failure to comply will result in personal injury or damage to the AC drive.
	 WARNING	<ul style="list-style-type: none"> Avoid objects falling into the AC drive when it is running. Failure to comply will result in damage to the AC drive. Do not start/stop the AC drive by turning the contactor ON/OFF. Failure to comply will result in damage to the AC drive.
During maintenance	 DANGER	<ul style="list-style-type: none"> Repair or maintenance of the AC drive may be performed only by qualified personnel. Failure to comply will result in personal injury or damage to the AC drive. Do not repair or maintain the AC drive at power-on. Failure to comply will result in electric shock. Repair or maintain the AC drive only ten minutes after the AC drive is powered off. This allows for the residual voltage in the capacitor to discharge to a safe value. Failure to comply will result in personal injury. Ensure that the AC drive is disconnected from all power supplies before starting repair or maintenance on the AC drive. Set and check the parameters again after the AC drive is replaced. All the pluggable components must be plugged or removed only after power-off. The rotating motor generally feeds back power to the AC drive. As a result, the AC drive is still charged even if the motor stops, and the power supply is cut off. Thus ensure that the AC drive is disconnected from the motor before starting repair or maintenance on the AC drive.

1.2 General Precautions

1) Requirement on residual current device (RCD)

The AC drive generates high leakage current during running, which flows through the protective earthing (PE) conductor. Thus install a type-B RCD at primary side of the power supply. When selecting the RCD, you should consider the transient and steady-state leakage current to ground that may be generated at startup and during running of the AC drive. You can select a specialized RCD with the function of suppressing high harmonics or a general-purpose RCD with relatively large residual current.

2) High leakage current warning

The AC drive generates high leakage current during running, which flows through the PE conductor. Earth connection must be done before connection of power supply. Earthing shall comply with local regulations and related IEC standards.

3) Motor insulation test

Perform the insulation test when the motor is used for the first time, or when it is reused after being stored for a long time, or in a regular check-up, in order to prevent the poor insulation of motor windings from damaging the AC drive. The motor must be disconnected from the AC drive during the insulation test. A 500-V mega-Ohm meter is recommended for the test. The insulation resistance must not be less than 5 MΩ.

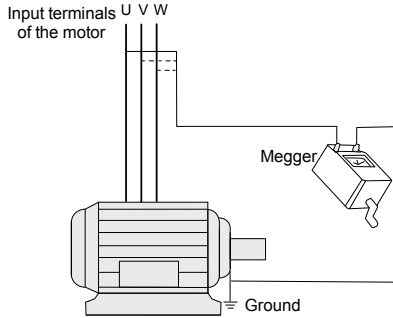

4) Thermal protection of motor

If the rated capacity of the motor selected does not match that of the AC drive, especially when the AC drive's rated power is greater than the motor's, adjust the motor protection parameters on the operation panel of the AC drive or install a thermal relay in the motor circuit for protection.

5) Running at over 50 Hz

The AC drive provides frequency output of 0 to 3200 Hz (Up to 300 Hz is supported if the AC drive runs in CLVC and SFVC mode). If the AC drive is required to run at over 50 Hz, consider the capacity of the machine.

6) Vibration of mechanical device

The AC drive may encounter the mechanical resonance point at some output frequencies, which can be avoided by setting the skip frequency.

7) Motor heat and noise

The output of the AC drive is pulse width modulation (PWM) wave with certain harmonic frequencies, and therefore, the motor temperature, noise, and vibration are slightly greater than those when the AC drive runs at power frequency (50 Hz).

8) Voltage-sensitive device or capacitor on output side of the AC drive

Do not install the capacitor for improving power factor or lightning protection voltage-sensitive resistor on the output side of the AC drive because the output of the AC drive is PWM wave. Otherwise, the AC drive may suffer transient overcurrent or even be damaged.

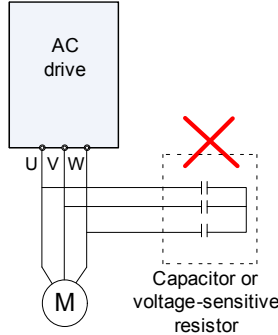

9) Contactor at the I/O terminal of the AC drive

When a contactor is installed between the input side of the AC drive and the power supply, the AC drive must not be started or stopped by switching the contactor on or off. If the AC drive has to be operated by the contactor, ensure that the time interval between switching is at least one hour since frequent charge and discharge will shorten the service life of the capacitor inside the AC drive.

When a contactor is installed between the output side of the AC drive and the motor, do not turn off the contactor when the AC drive is active. Otherwise, modules inside the AC drive may be damaged.

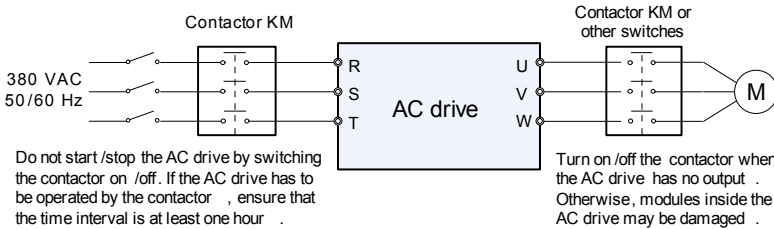

10) When external voltage is out of rated voltage range

The AC drive must not be used outside the allowable voltage range specified in this manual. Otherwise, the AC drive's components may be damaged. If required, use a corresponding voltage step-up or step-down device.

11) Prohibition of three-phase input changed into two-phase input

Do not change the three-phase input of the AC drive into two-phase input. Otherwise, a fault will result or the AC drive will be damaged.

12) Surge suppressor

The AC drive has a built-in voltage dependent resistor (VDR) for suppressing the surge voltage generated when the inductive loads (electromagnetic contactor, electromagnetic relay, solenoid valve, electromagnetic coil and electromagnetic brake) around the AC drive are switched on or off. If the inductive loads generate a very high surge voltage, use a surge suppressor for the inductive load or also use a diode.

Note

Do not connect the surge suppressor on the output side of the AC.

13) Altitude and de-rating

In places where the altitude is above 1000 m and the cooling effect reduces due to thin air, it is necessary to de-rate the AC drive. Contact Inovance for technical support.

14) Some special usages

If wiring that is not described in this manual such as common DC bus is applied, contact the agent or Inovance for technical support.

15) Disposal

The electrolytic capacitors on the main circuits and PCB may explode when they are burnt. Poisonous gas is generated when the plastic parts are burnt. Treat them as ordinary industrial waste.

16) Adaptable Motor

- The standard adaptable motor is adaptable four-pole squirrel-cage asynchronous induction motor or PMSM. For other types of motor, select a proper AC drive according to the rated motor current.
- The cooling fan and rotor shaft of non-variable-frequency motor are coaxial, which results in reduced cooling effect when the rotational speed declines. If variable speed is required, add a more powerful fan or replace it with variable-frequency motor in applications where the motor overheats easily.
- The standard parameters of the adaptable motor have been configured inside the AC drive. It is still necessary to perform motor auto-tuning or modify the default values based on actual conditions. Otherwise, the running result and protection performance will be affected.
- The AC drive may alarm or even be damaged when short-circuit exists on cables or inside the motor. Therefore, perform insulation short-circuit test when the motor and cables are newly installed or during routine maintenance. During the test, make sure that the AC drive is disconnected from the tested parts.



Product Information

Chapter 2 Product Information

2.1 Designation Rules and Nameplate of the MD380

Figure 2-1 Designation rules and nameplate of the MD380

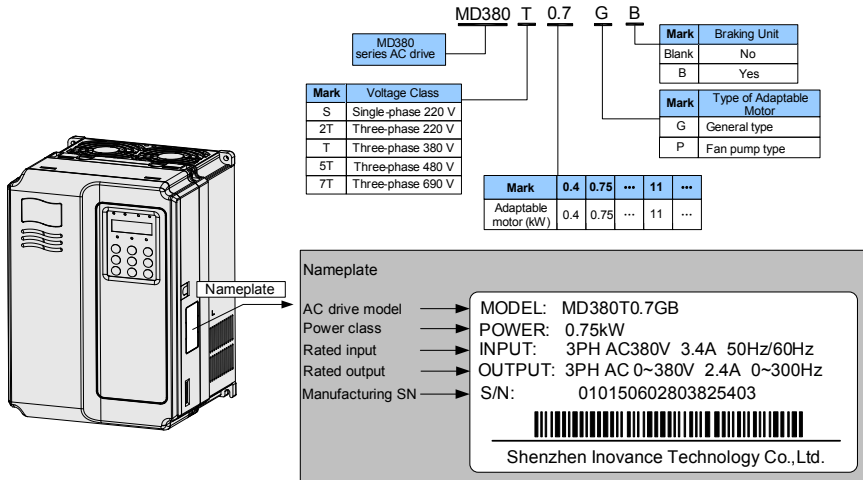

2.2 Components of the MD380

The MD380 series AC drives have two housing types, plastic housing and sheet metal housing, according to different voltage and power classes.

Figure 2-2 Components of the MD380 series AC drive (plastic housing)

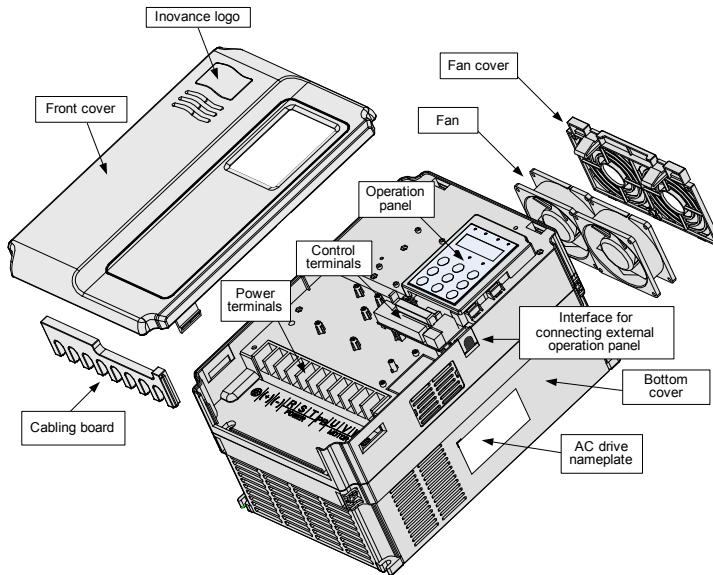
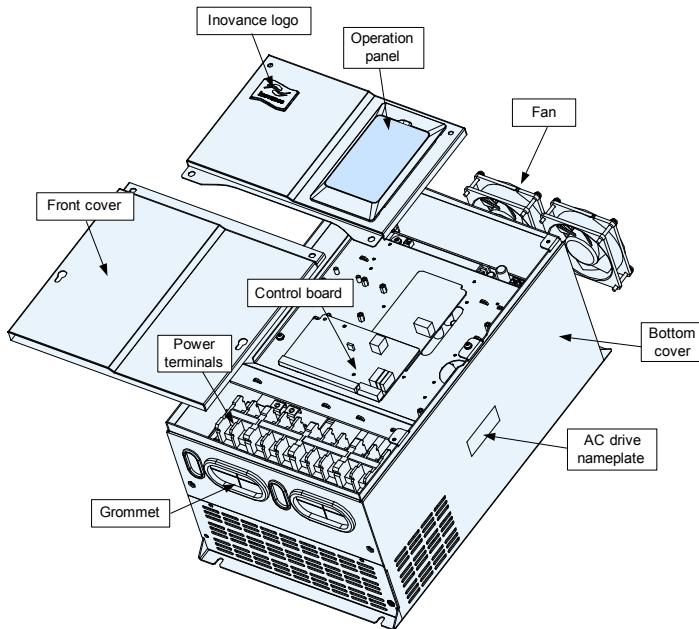

Figure 2-3 Components of the MD380 series AC drive (sheet metal housing)



The housing types of the MD380 models with different voltage and power classes are listed in the following table.

Table 2-1 Housing types for different voltage and power classes

Voltage & Power Class	Housing Type
Single-phase 220 V	
0.4–2.2 kW	Plastic housing
Three-phase 220 V	
0.4–7.5 kW	Plastic housing
11–75 kW	Sheet metal housing
Three-phase 380 V	
0.75–15 kW	Plastic housing
18.5–400 kW	Sheet metal housing
Three-phase 480 V	
0.75–15 kW	Plastic housing
18.5–400 kW	Sheet metal housing
Three-phase 690 V	
55–500 kW	Sheet metal housing

2.3 Technical Specifications

Table 2-2 Technical specifications of the MD380

Item	Specifications		
Standard functions	Maximum frequency	<ul style="list-style-type: none"> • Vector control: 0–300 Hz • V/F control: 0–320 Hz 	
	Carrier frequency	0.5–16 kHz The carrier frequency is automatically adjusted based on the load features.	
	Input frequency resolution	Digital setting: 0.01 Hz Analog setting: maximum frequency x 0.025%	
	Control mode	<ul style="list-style-type: none"> • Sensorless flux vector control (SFVC) • Closed-loop vector control (CLVC) • Voltage/Frequency (V/F) control 	
	Startup torque	<ul style="list-style-type: none"> • G type: 0.5 Hz/150% (SFVC); 0 Hz/180% (CLVC) • P type: 0.5 Hz/100% 	
	Speed range	1:100 (SFVC)	1:1000 (CLVC)
	Speed stability accuracy	<ul style="list-style-type: none"> • $\pm 0.5\%$ (SFVC) • $\pm 0.02\%$ (CLVC) 	
	Torque control accuracy	$\pm 5\%$ (CLVC)	

Item		Specifications
Standard functions	Overload capacity	<ul style="list-style-type: none"> G type: 60s for 150% of the rated current, 3s for 180% of the rated current P type: 60s for 120% of the rated current, 3s for 150% of the rated current
	Torque boost	<ul style="list-style-type: none"> Fixed boost Customized boost 0.1%–30.0%
	V/F curve	<ul style="list-style-type: none"> Straight-line V/F curve Multi-point V/F curve N-power V/F curve (1.2-power, 1.4-power, 1.6-power, 1.8-power, square)
	V/F separation	Two types: complete separation; half separation
	Ramp mode	<ul style="list-style-type: none"> Straight-line ramp S-curve ramp Four groups of acceleration/deceleration time with the range of 0.0–6500.0s
	DC braking	DC braking frequency: 0.00 Hz to maximum frequency Braking time: 0.0–36.0s Braking action current value: 0.0%–100.0%
	JOG control	JOG frequency range: 0.00–50.00 Hz JOG acceleration/deceleration time: 0.0–6500.0s
	Onboard multiple preset speeds	It implements up to 16 speeds via the simple PLC function or combination of DI terminal states.
	Onboard PID	It realizes process-controlled closed loop control system easily.
	Auto voltage regulation (AVR)	It can keep constant output voltage automatically when the mains voltage changes.
	Overvoltage/ Overcurrent stall control	The current and voltage are limited automatically during the running process so as to avoid frequent tripping due to overvoltage/overcurrent.
	Torque limit and control	It can limit the torque automatically and prevent frequent over current tripping during the running process. Torque control can be implemented in the CLVC mode.
	Individualized functions	High performance
Power dip ride through		The load feedback energy compensates the voltage reduction so that the AC drive can continue to run for a short time.
Rapid current limit		It helps to avoid frequent overcurrent faults of the AC drive.
Virtual I/Os		Five groups of virtual DI/Dos can realize simple logic control.
Timing control		Time range: 0.0–6500.0 minutes

Item		Specifications
Individualized functions	Multi-motor switchover	Four motors can be switched over via four groups of motor parameters.
	Multiple communication protocols	It supports communication via Modbus-RTU, PROFIBUS-DP, CANlink and CANopen.
	Motor overheat protection	The optional I/O extension card enables AI3 to receive the motor temperature sensor input (PT100, PT1000) so as to realize motor overheat protection.
	Multiple encoder types	It supports various encoders such as differential encoder, open-collector encoder, resolver, UVW encoder, and SIN/COS encoder.
	User programmable function	The optional programming card helps you to realize secondary development. Its programming environment is compatible with that of the PLC of Inovance.
	Advanced background software	It supports the operation of AC drive parameters and virtual oscillograph function, via which the state inside the AC drive is monitored.
RUN	Running command source	<ul style="list-style-type: none"> • Operation panel • Control terminals • Serial communication port You can perform switchover between these sources in various ways.
	Frequency source	There are a total of 10 frequency sources, such as digital setting, analog voltage setting, analog current setting, pulse setting and serial communication port setting. You can perform switchover between these sources in various ways.
	Auxiliary frequency source	There are ten auxiliary frequency sources. It can implement fine tuning of auxiliary frequency and frequency synthesis.
	Input terminal	Standard: 5 digital input (DI) terminals, one of which supports up to 100 kHz high-speed pulse input 2 analog input (AI) terminals, one of which only supports 0–10 V voltage input and the other supports 0–10 V voltage input or 4–20 mA current input Expanding capacity: 5 DI terminals 1 AI terminal that supports -10–10 V voltage input and also supports PT100\PT1000

Item		Specifications
RUN	Output terminal	Standard 1 high-speed pulse output terminal (open-collector) that supports 0–100 kHz square wave signal output 1 digital output (DO) terminal 1 relay output terminal 1 analog output (AO) terminal that supports 0–20 mA current output or 0–10 V voltage output Expanding capacity: 1 DO terminal 1 relay output terminal 1 AO terminal that supports 0–20 mA current output or 0–10 V voltage output
Display and operation on the operation panel	LED display	It displays the parameters.
	Key locking and function selection	It can lock the keys partially or completely and define the function range of some keys so as to prevent mis-function.
	Protection mode	Motor short-circuit detection at power-on, input/output phase loss protection, overcurrent protection, overvoltage protection, undervoltage protection, overheat protection and overload protection
	Optional parts	LCD operation panel, braking unit, I/O extension card 1, I/O extension card 2, user programmable card, RS485 communication card, PROFIBUS-DP communication card, CANlink communication card, CANopen communication card, differential input PG card, UVW differential input PG card, resolver PG card and OC input PG card
Environment	Installation location	Indoor, free from direct sunlight, dust, corrosive gas, combustible gas, oil smoke, vapour, drip or salt.
	Altitude	Lower than 1000 m
	Ambient temperature	-10°C to +40°C (de-rated if the ambient temperature is between 40°C and 50°C)
	Humidity	Less than 95%RH, without condensing
	Vibration	Less than 5.9 m/s ² (0.6 g)
	Storage temperature	-20°C to +60°C
	IP level	IP20
	Pollution degree	PD2
	Power distribution system	TN , TT

2.4 Peripheral Electrical Devices and System Configuration

When the MD380 is used to control the synchronous or asynchronous motor, forming a control system, it is necessary to install various electrical devices on the input and output sides of the AC drive to ensure the system safety and stability.

In addition, several optional extension cards are available for the MD380 to implement various functions. The system configuration of three-phase 220 V/380 V/480 V voltage class, 3.7 kW and above is shown in the following figure.

Figure 2-4 System configuration of three-phase 220 V/380 V/480 V voltage class, 3.7 kW and above

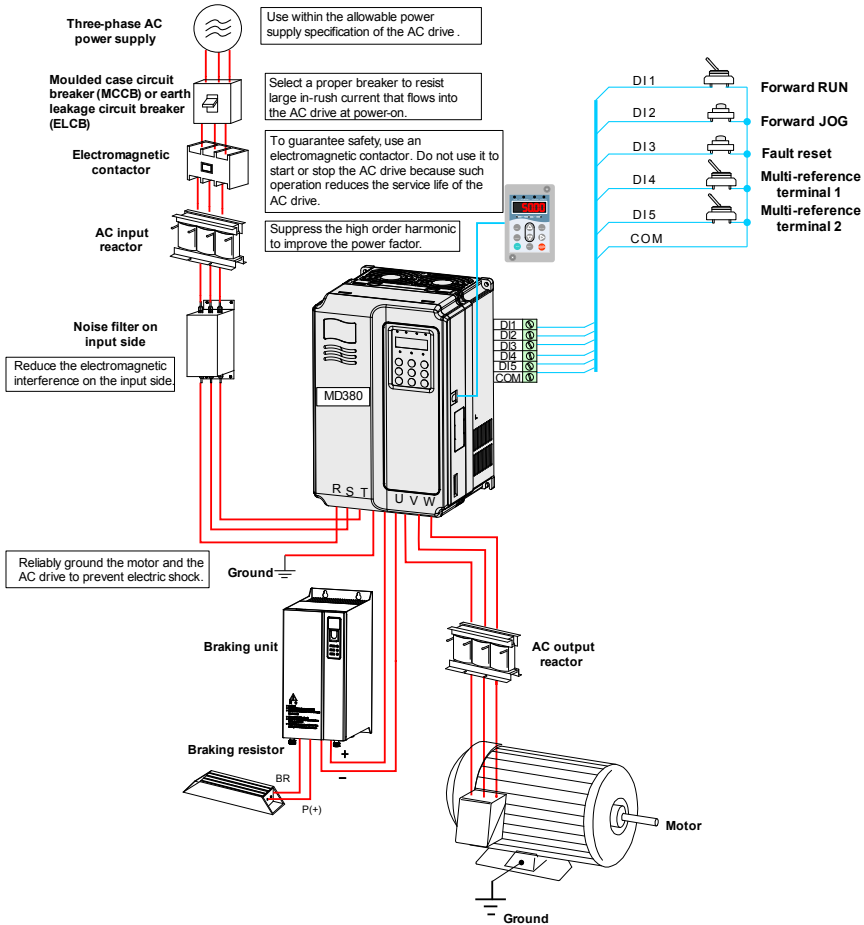

2.4.1 Description of Peripheral Electrical Devices

Table 2-3 Description of peripheral electrical devices

Part	Mounting Location	Function Description
MCCB	Power receiving side	Interrupt the power supply when overcurrent occurs on downstream devices
Contactor	Between MCCB and AC drive input side	Start and stop the AC drive. Do not start and stop the AC drive frequently by switching the contactor on and off (less than twice per minute) nor use it to directly start the AC drive.
AC input reactor	AC drive input side	<ul style="list-style-type: none"> Improve the power factor of the input side. Eliminate the higher harmonics of the input side effectively and prevent other devices from being damaged due to distortion of the voltage waveform. Eliminate the input current unbalance due to unbalance between the power phases.
EMC Input filter	AC drive input side	<ul style="list-style-type: none"> Reduce the external conduction and radiation interference of the AC drive. Decrease the conduction interference flowing from the power end to the AC drive and improve the anti-interference capacity of the AC drive.
DC reactor	MD series AC drive of 7.5G and above configured with DC reactor as standard	<ul style="list-style-type: none"> Improve the power factor of the input side. Improve the efficiency and thermal stability of the AC drive. Eliminate the impact of higher harmonics of the AC drive input side and reduce the external conduction and radiation interference.
AC output reactor	Between AC drive output side and the motor, close to the AC drive	<p>The output side of the AC drive generally has much higher harmonics. When the motor is far from the AC drive, there is much distributed capacitance in the circuit and certain harmonics may cause resonance in the circuit, bringing about the following two impacts:</p> <ul style="list-style-type: none"> Degrade the motor insulation performance and damage the motor in the long run. Generate large leakage current and cause frequent AC drive protection trips. <p>If the distance between the AC drive and the motor is greater than 100 m, install an AC output reactor.</p>

- 1) Do not install the capacitor or surge suppressor on the output side of the AC drive. Otherwise, it may cause faults to the AC drive or damage to the capacitor and surge suppressor.
- 2) Inputs/Outputs (main circuit) of the AC drive contain harmonics, which may interfere with the communication device connected to the AC drive. Therefore, install an anti-interference filter to minimize the interference.
- 3) For more details on peripheral devices, refer to related selection manual.

2.4.2 Description of Optional Parts

The optional parts include braking unit, extension cards of different functions and external operation panel, etc. If any optional part is required, specify it in your order.

Table 2-4 Optional parts of the MD380

Name	Model	Function	Remark
Internal braking unit	AC drive model followed by letter B	The models of single-phase (0.4–2.2 kW) and three-phase (0.75–15 kW) are installed with the internal braking unit as standard configuration.	Internal braking unit is optional for the models of 18.5–30 kW.
External braking unit	MDBUN	The MD380 AC drives of 37 kW and above need to be configured with an external braking unit.	Multiple braking units are connected in parallel for the models of 75 kW and above.
Regenerative unit	MDFB	As an energy-saving part, it feeds back the electricity of the AC drive to the AC mains.	
Rectifying unit	MDRU	It is used in common bus and has energy saving function.	
I/O extension card 1	MD38IO1	It can extend 5 DI, 1 AI (AI3 is used for separation analog input and can be connected to PT100, PT1000), 1 relay output, 1 DO and 1 AO, RS485 and CANlink communication terminal	It applies to the models of 3.7 kW and above.
I/O extension card 2-Size B	MD38IO2	It can extend 3 DI.	It applies to all models.
Modbus communication card	MD38TX1	It is the RS485 communication card with isolation.	It applies to all models.
CANlink communication card	MD38CAN1	It is the CANlink communication card.	It applies to all models.
CANopen communication card	MD38CAN2	It is the CANopen communication card.	It applies to all models.
Profibus-DP communication card	MD38DP	It is the Profibus-DP communication card.	It applies to the models of 3.7 kW and above.
User programmable card	MD38PC1	It is compatible to Inovance's H1U series PLC.	It applies to the models of 3.7 kW and above.

Name	Model	Function	Remark
Differential encoder interface card	MD38PG1	It is the differential resolver interface card. It is adaptable to 5 V power supply	It applies to all models.
UVW encoder interface card	MD38PG3	It is suitable for the UVW differential encoder and applied to synchronous motor. It is adaptable to 5 V power supply	It applies to all models.
Resolver interface card	MD38PG4	It is applied to the resolver. 10 kHz excitation frequency, DB9 interface	It applies to all models.
Open-collector encoder interface card	MD38PG5	It is the open-collector encoder interface card with 1:1 frequency division output. It is adaptable to 15 V power supply.	It applies to all models.
External LED operation panel	MDKE	It supports LED display and operations.	It applies to the MD series AC drives with the RJ45 interface.
Extension cable	MDCAB	It is a standard 8-core cable and can be connected to MDKE, MD32KC and MDCP.	The standard length is 3 meters.



Mechanical and Electrical Installation

Chapter 3 Mechanical and Electrical Installation

3.1 Mechanical Installation

3.1.1 Installation Environment Requirements

Item	Requirements
Ambient temperature	-10°C to +50°C
Heat dissipation	Install the AC drive on the surface of an incombustible object, and ensure that there is sufficient space around for heat dissipation. Install the AC drive vertically on the support using screws.
Mounting location	Free from direct sunlight, high humidity and condensation
	Free from corrosive, explosive and combustible gas
	Free from oil dirt, dust and metal powder
Vibration	Less than 0.6 g
	Far away from the punching machine or the like
Protective enclosure	The MD380 series AC drives of plastic housing are the whole unit built-in products operated through remote control and need to be installed in the final system. The final system must have the required fireproof cover, electrical protective cover and mechanical protective cover, and satisfy the regional laws & regulations and related IEC requirements.

3.1.2 Installation Clearance Requirements

The clearance that needs to be reserved varies with the power class of the MD380, as shown in the following figure.

Figure 3-1 Clearance around the MD380 for installation

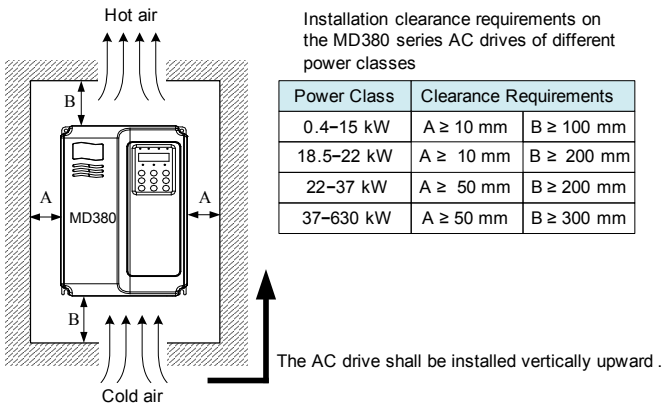

The MD380 series AC drive dissipates heat from the bottom to the top. When multiple AC drives are required to work together, install them side by side.

For application installing multiple AC drives, if one row of AC drives need to be installed above another row, install an insulation guide plate to prevent AC drives in the lower row from heating those in the upper row and causing faults.

Figure 3-2 Installation of the insulation guide plate

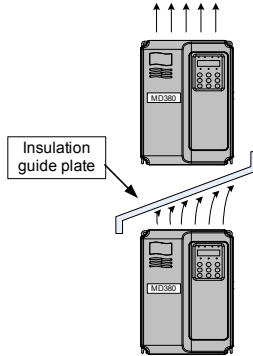

3.1.3 Mechanical Installation Method and Process

The MD380 series AC drives have two housing types, plastic housing and sheet metal housing, according to different voltage and power classes. The MD380 supports both wall-mounting installation and embedded installation in different applications.

- 1) Wall-mounting installation of the MD380 (plastic housing)

Figure 3-3 Wall-mounting installation of the MD380 (plastic housing)

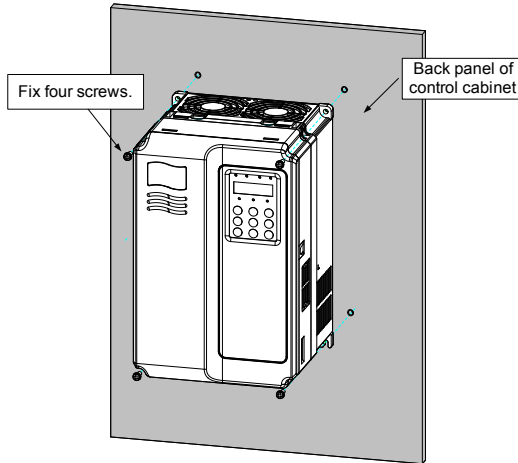

2) Embedded installation of the MD380 (plastic housing)

Figure 3-4 External hanging bracket for the MD380

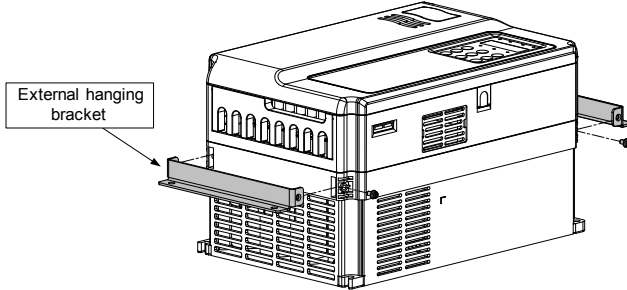

Figure 3-5 Embedded installation of the MD380 (plastic housing)

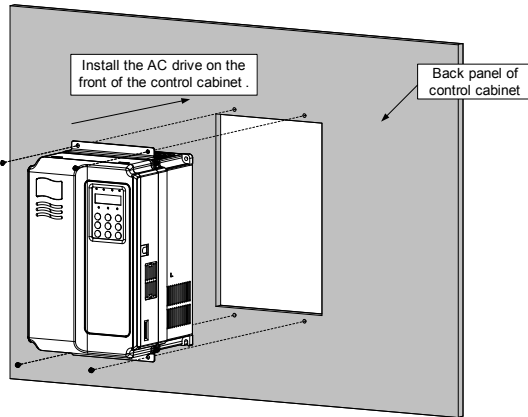
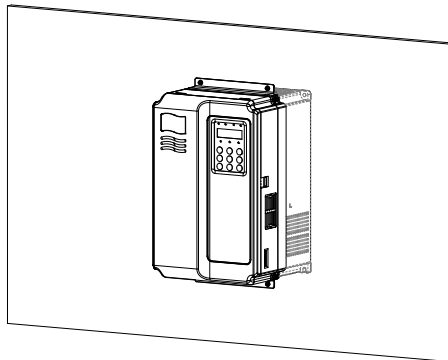

Figure 3-6 Embedded installation effect of the MD380 (plastic housing)



3) Wall-mounting installation of the MD380 (sheet metal housing)

Figure 3-7 Wall-mounting installation of the MD380 (sheet metal housing)

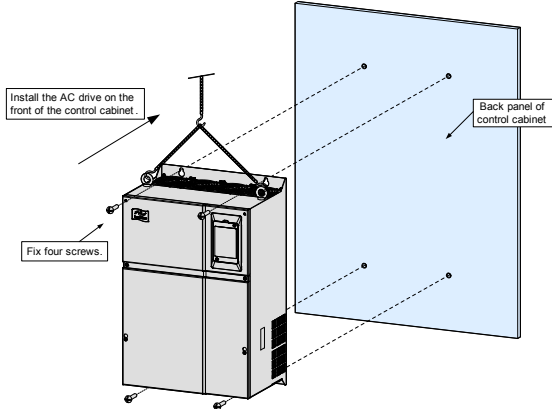
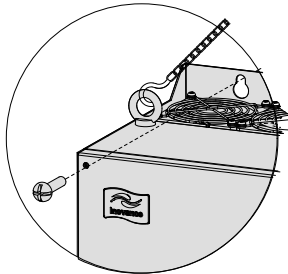

Figure 3-8 Hoisting the MD380 (sheet metal housing)



4) Embedded installation of the MD380 (sheet metal housing)

Figure 3-9 External hanging bracket for the MD380 (sheet metal housing)

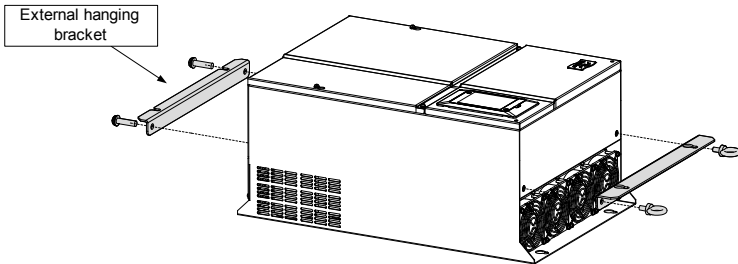

Figure 3-10 Embedded installation of the MD380 (sheet metal housing)

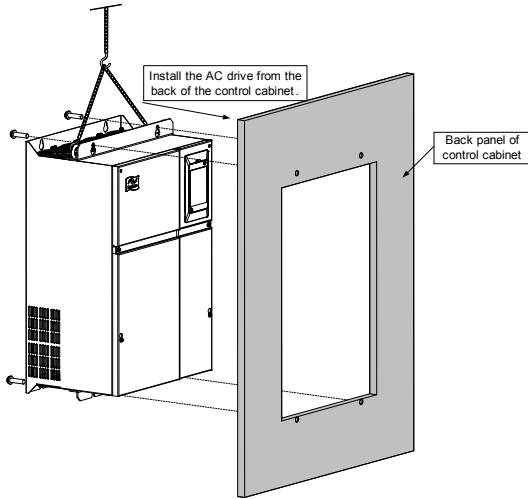

Figure 3-11 Embedded installation effect of the MD380 (sheet metal housing)



■ Installation Precautions

- 1) Reserve the installation clearances as specified in Figure 3-1 to ensure sufficient space for heat dissipation. Take heat dissipation of other parts in the cabinet into consideration.
- 2) Install the AC drives upright to facilitate heat dissipation. If multiple AC drives are installed in the cabinet, install them side by side. If one row of AC drives need to be installed above another row, install an insulation guide plate, as shown in Figure 3-2.
- 3) Use incombustible hanging bracket.
- 4) In scenarios with heavy metal powder, install the heatsink outside the cabinet, and ensure that the room inside the fully-sealed cabinet is as large as possible.

3.1.4 Removal of the Front Cover of the MD380

For the MD380 series AC drives, you need to remove the front cover and before wiring the main circuit and control circuit.

Figure 3-12 Removal of the front cover of the MD380 (plastic housing)

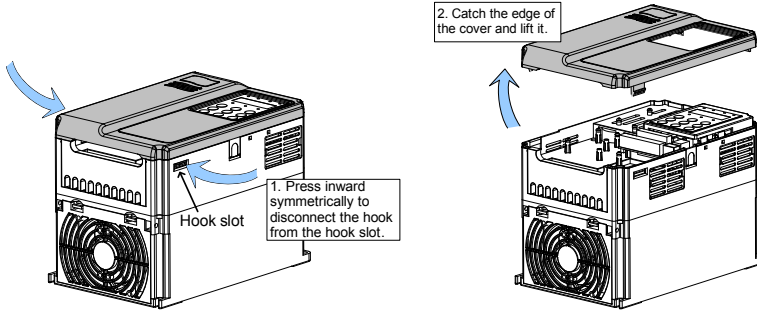
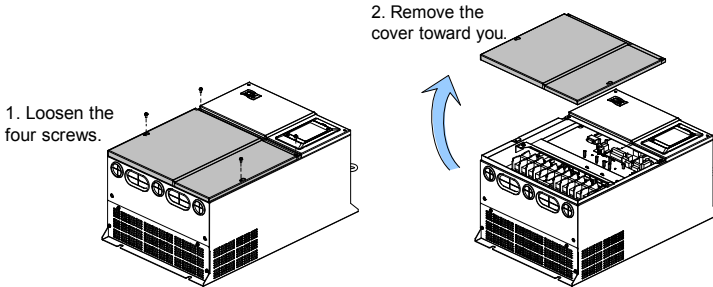

Figure 3-13 Removal of the front cover of the MD380 (sheet metal housing)



Prevent the cover from falling off during the removal to avoid potential damage to the equipment or personal injury.

3.2 Electrical Installation

3.2.1 Description of Main Circuit Terminals

■ Description of Main Circuit Terminals of Single-phase AC drive

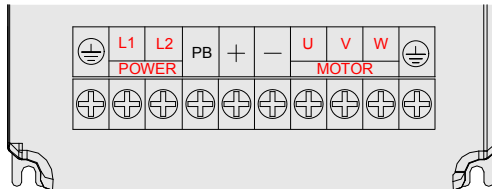



Table 3-1 Description of main circuit terminals of single-phase AC drive

Terminal	Name	Description
L1, L2	Single-phase power supply input terminals	Connect to the single-phase 220 VAC power supply.
(+), (-)	Positive and negative terminals of DC bus	Common DC bus input point.
(+), PB	Connecting terminals of braking resistor	Connect to a braking resistor.
U, V, W	AC drive output terminals	Connect to a three-phase motor.
	Grounding terminal	Must be grounded.

■ Description of Main Circuit Terminals of Three-phase AC drive

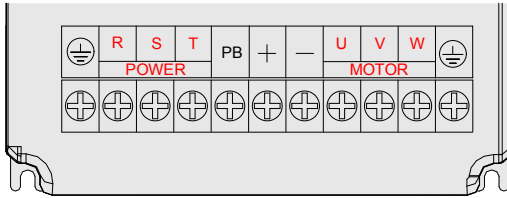



Table 3-2 Description of main circuit terminals of three-phase AC drive

Terminal	Name	Description
R, S, T	Three-phase power supply input terminals	Connect to the three-phase AC power supply
(+), (-)	Positive and negative terminals of DC bus	Common DC bus input point Connect the external braking unit to the AC drive of 18.5 kW and above (220 V) and 37 kW and above (other voltage classes).
(+), PB	Connecting terminals of braking resistor	Connect to the braking resistor for the AC drive of 15 kW and below (220 V) and 30 kW and below (other voltage classes).
P, (+)	Connecting terminals of external reactor	Connect to an external reactor.
U, V, W	AC drive output terminals	Connect to a three-phase motor.
	Grounding terminal	Must be grounded.

3.2.2 Wiring of AC Drive Main Circuit

Table 3-3 Wiring of the AC drive main circuit

Single-phase 220 V	Three-phase 220 V (15 kW and Below)
Three-phase 220 V (18.5–30 kW)	Three-phase 220 V (37 kW and Above)
Three-phase 380/480 V (30 kW and Below)	Three-phase 380/480 V (37–55 kW)
Three-phase 380/480 V (75 kW and Above)	Three-phase 690 V

■ Precautions on the Wiring

1) Power input terminals L1, L2 or R, S, T

- The cable connection on the input side of the AC drive has no phase sequence requirement.
- The specification and installation method of external power cables must comply with the local safety regulations and related IEC standards.
- Use copper conductors of a proper size as power cables according to the recommended values in section 8.3.

2) DC bus terminals (+), (-)

- Terminals (+) and (-) of DC bus have residual voltage after the AC drive is switched off. After indicator CHARGE goes off, wait at least 10 minutes before touching the equipment. Otherwise, you may get electric shock.
- connecting external braking components for the AC drive of 18.5 kW and above (220 V) and 37 kW and above (other voltage classes), do not reverse poles (+) and (-). Otherwise, it may damage the AC drive and even cause a fire.
- The cable length of the braking unit shall be no longer than 10 m. Use twisted pair wire or pair wires for parallel connection.
- Do not connect the braking resistor directly to the DC bus. Otherwise, it may damage the AC drive and even cause fire.

3) Braking resistor connecting terminals (+), PB

- The connecting terminals of the braking resistor are effective only for the AC configured with the built-in braking unit.
- The cable length of the braking resistor shall be less than 5 m. Otherwise, it may damage the AC drive.

4) External reactor connecting terminals P, (+)

For the AC drive of 37 kW and above (220 V) and 75 kW and above (other voltage classes), remove the jumper bar across terminals P and (+) and install the reactor between the two terminals.

5) AC drive output terminals U, V, W

- The specification and installation method of external power cables must comply with the local safety regulations and related IEC standards.
- Use copper conductors of a proper size as power cables according to the recommended values in section 8.3.
- The capacitor or surge absorber cannot be connected to the output side of the AC drive. Otherwise, it may cause frequent AC drive fault or even damage the AC drive.
- If the motor cable is too long, electrical resonance will be generated due to the impact of distributed capacitance. This will damage the motor insulation or generate higher leakage current, causing the AC drive to trip in overcurrent protection. If the motor cable is greater than 100 m long, an AC output reactor must be installed close to the AC drive.

6) Terminal  PE

- This terminal must be reliably connected to the main earthing conductor. Otherwise, it may cause electric shock, mal-function or even damage to the AC drive.

- Do not connect the earthing terminal to the neutral conductor of the power supply.
- The impedance of the PE conductor must be able to withstand the large short-circuit current that may arise when a fault occurs.
- Select the size of the PE conductor according to the following table:

Cross-sectional Area of a Phase Conductor (S)	Min. Cross-sectional Area of Protective Conductor (Sp)
$S \leq 16 \text{ mm}^2$	S
$16 \text{ mm}^2 < S \leq 35 \text{ mm}^2$	16 mm^2
$35 \text{ mm}^2 < S$	S/2

- You must use a yellow/green cable as the PE conductor.

7) Requirements on upstream protection device

- Install upstream protection device on the input power circuit. The protection device must provide the protections on overcurrent, short-circuit and electrical isolation.
- When selecting the protective device, you should consider the current capacity of the power cable, system overload capacity and short-circuit capacity of the upstream power distribution of the equipment. Generally, make selection according to the recommended values in section 8.4.

3.2.3 Description of Control Circuit Terminals

■ Terminal Arrangement of Control Circuit

+10V	AI1	AI2	DI1	DI2	DI3	DI4	DI5	COM			
GND	GND	AO1	CME	COM	DO1	FM	+24V	OP	T/A	T/B	T/C

■ Description of Control Circuit Terminals

Table 3-3 Description of control circuit terminals

Type	Terminal	Name	Function Description
Power supply	+10V-GND	External +10 V power supply	Provide +10 V power supply to external unit. Generally, it provides power supply to external potentiometer with resistance range of 1–5 kΩ. Maximum output current: 10 mA
	+24V-COM	External +24 V power supply Applying to Overvoltage Category II circuit	Provide +24 V power supply to external unit. Generally, it provides power supply to DI/DO terminals and external sensors. Maximum output current: 200 mA
	OP	Input terminal of external power supply	Connect to +24 V by default. When DI1-DI5 need to be driven by external signal, OP needs to be connected to external power supply and be disconnected from +24 V.

Type	Terminal	Name	Function Description
Analog input	AI1-GND	Analog input 1	Input voltage range: 0–10 VDC Impedance: 22 k Ω
	AI2-GND	Analog input 2	Input range: 0–10 VDC/4–20 mA, decided by jumper J8 on the control board Impedance: 22 k Ω (voltage input), 500 Ω (current input)
Digital input	DI1- OP	Digital input 1	Optical coupling isolation, compatible with dual polarity input Impedance: 2.4 k Ω Voltage range for level input: 9–30 V
	DI2- OP	Digital input 2	
	DI3- OP	Digital input 3	
	DI4- OP	Digital input 4	
	DI5- OP	High-speed pulse input	Besides features of DI1–DI4, it can be used for high-speed pulse input. Maximum input frequency: 100 kHz
Analog output	AO1-GND	Analog output 1	Voltage or current output is decided by jumper J5. Output voltage range: 0–10 V Output current range: 0–20 mA
Digital output	DO1-CME	Digital output 1	Optical coupling isolation, dual polarity open collector output Output voltage range: 0–24 V Output current range: 0–50 mA Note that CME and COM are internally insulated, but they are shorted by jumper externally. In this case DO1 is driven by +24 V by default. If you want to drive DO1 by external power supply, remove the jumper.
	FM- COM	High-speed pulse output	It is limited by F5-00 (FM terminal output mode selection). As high-speed pulse output, the maximum frequency hits 100 kHz. As open-collector output, its specification is the same as that of DO1
Relay output	T/A-T/B	NC terminal	Contact driving capacity: 250 VAC, 3 A, COS ϕ = 0.4 30 VDC, 1 A Applying to Overvoltage Category II circuit
	T/A-T/C	NO terminal	
Auxiliary interface	J12	Extension card interface	I28-pin terminal Connect to an optional card (I/O extension card, PLC card and various bus cards)
	J3	PG card interface	Support various types of PG cards: OC, differential, UVW and resolver.
	J7	External operation panel interface	Connect to external operation panel.

3.2.4 Wiring of AC Drive Control Circuit

Figure 3-14 Wiring mode of the AC drive control circuit

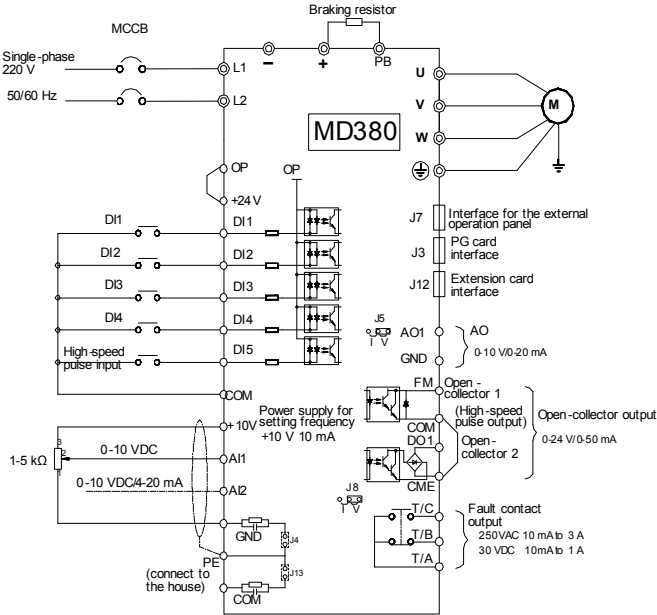

Note

- All MD380 series AC drives have the same wiring mode. The figure here shows the wiring of single-phase 220 VAC drive. ⊙ indicates main circuit terminal, while ○ indicates control circuit terminal.
- When the external operation panel is connected, the display of the operation panel on the MD380 goes off.

■ Description of Wiring of Signal Terminals

1) Wiring of AI terminals

Weak analog voltage signals are easy to suffer external interference, and therefore the shielded cable must be used and the cable length must be less than 20 m, as shown in following figure.

Figure 3-15 Wiring mode of AI terminals

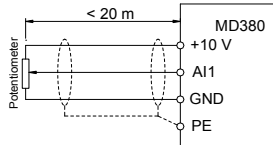

In applications where the analog signal suffers severe interference, install filter capacitor or ferrite magnetic core at the analog signal source.

Figure 3-16 Install filter capacitor or ferrite magnetic core

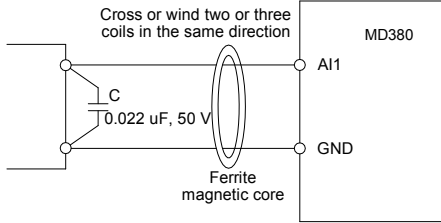

2) Wiring of DI terminals

Generally, select shielded cable no longer than 20 m. When active driving is adopted, necessary filtering measures shall be taken to prevent the interference to the power supply. It is recommended to use the contact control mode.

a. SINK wiring

Figure 3-17 Wiring in SINK mode

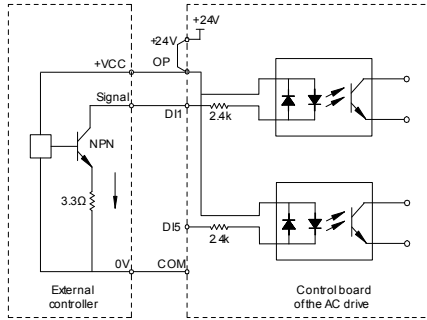

This is the most commonly used wiring mode. To apply external power supply, remove jumpers between +24 V and OP and between COM and CME, and connect the positive pole of external power supply to OP and negative pole to CME.

In such wiring mode, the DI terminals of different AC drives cannot be connected in parallel. Otherwise, DI mal-function may result. If parallel connection (different AC drives) is required, connect a diode in series at the DI and the diode needs to satisfy the requirement: IF > 10 mA, UF < 1 V.

Figure 3-18 DI terminals connected in parallel in SINK mode

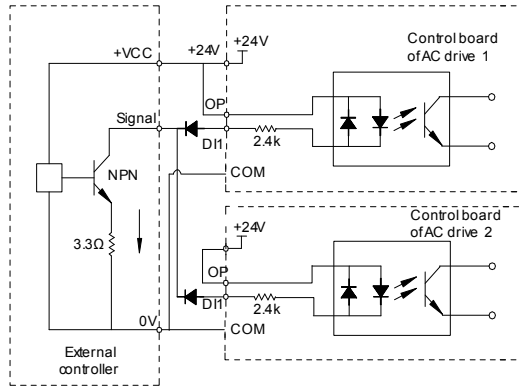

b. SOURCE wiring

In such wiring mode, remove the jumper between +24 V and OP. Connect +24 V to the common port of external controller and meanwhile connect OP to COM. If external power supply is applied, remove the jumper between CME and COM.

Figure 3-19 Wiring in SOURCE mode

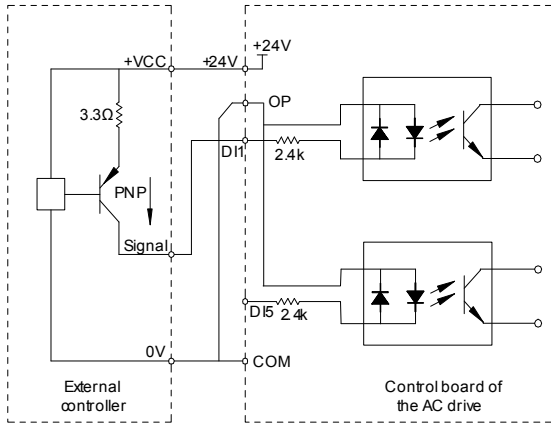

3) Wiring of DO terminal

When the digital output terminal needs to drive the relay, an absorption diode shall be installed between two sides of the relay coil. Otherwise, it may cause damage to the 24 VDC power supply. The driving capacity is not more than 50 mA.

Note

Do not reverse the polarity of the absorption diode during installation, as shown in Figure 3-11. Otherwise, the 24 VDC power supply will be damaged immediately once there is digital output.

Figure 3-20 DO terminal wiring diagram

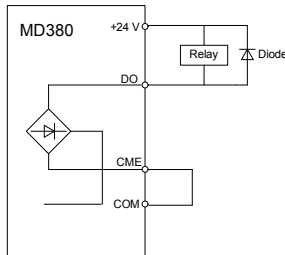

3.2.5 Electric Wiring of the MD380

Figure 3-21 Electric wiring of the MD380

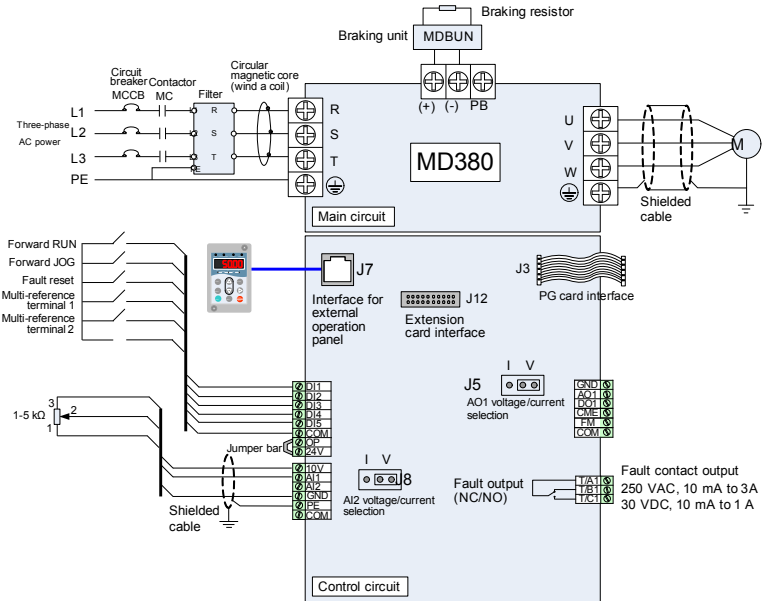



Operation, Display and Application Examples

Chapter 4 Operation, Display and Application Examples

4.1 Operation Panel

You can modify the parameters, monitor the working status and start or stop the MD380 by operating the operation panel, as shown in the following figure.

Figure 4-1 Diagram of the operation panel

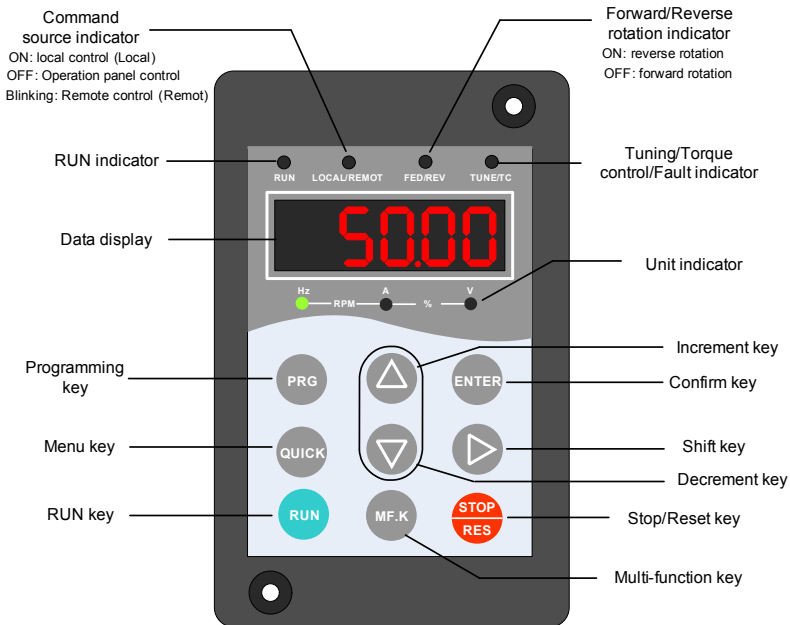

4.1.1 Description of Indicators







- RUN**
ON indicates that the AC drive is in the running state, and OFF indicates that the AC drive is in the stop state.
- LOCAL/REMOT**
It indicates whether the AC drive is operated by means of operation panel, terminals or communication.

○ LOCAL/REMOT: OFF	Operation panel control
● LOCAL/REMOT: ON	Terminal control
◐ LOCAL/REMOT: blinking	Communication control

- FWD/REV
ON indicates reverse rotation, and OFF indicates forward rotation.
- TUNE/TC
When the indicator is ON, it indicates torque control mode. When the indicator is blinking slowly, it indicates the auto-tuning state. When the indicator is blinking quickly, it indicates the fault state.
- Unit Indicators
● means that the indicator is ON, and ○ means that the indicator is OFF.
 Hz: unit of frequency
 $\text{Hz} \begin{matrix} \bullet \\ \text{---} \end{matrix} \text{RPM} \begin{matrix} \text{---} \\ \circ \end{matrix} \begin{matrix} \text{---} \\ \% \end{matrix} \begin{matrix} \text{---} \\ \circ \end{matrix} \text{V}$
 A: unit of current
 $\text{Hz} \begin{matrix} \circ \\ \text{---} \end{matrix} \text{RPM} \begin{matrix} \bullet \\ \text{---} \end{matrix} \begin{matrix} \text{---} \\ \% \end{matrix} \begin{matrix} \text{---} \\ \circ \end{matrix} \text{V}$
 V: unit of voltage
 $\text{Hz} \begin{matrix} \circ \\ \text{---} \end{matrix} \text{RPM} \begin{matrix} \circ \\ \text{---} \end{matrix} \begin{matrix} \text{---} \\ \% \end{matrix} \begin{matrix} \bullet \\ \text{---} \end{matrix} \text{V}$
 RPM: unit of rotational speed
 $\text{Hz} \begin{matrix} \bullet \\ \text{---} \end{matrix} \text{RPM} \begin{matrix} \bullet \\ \text{---} \end{matrix} \begin{matrix} \text{---} \\ \% \end{matrix} \begin{matrix} \text{---} \\ \circ \end{matrix} \text{V}$
 %: percentage
- Digital Display
The 5-digit LED display is able to display the set frequency, output frequency, monitoring data and fault codes.

4.1.2 Description of Keys on the Operation Panel

Table 4-1 Description of keys on the operation panel

Key	Name	Function
	Programming	Enter or exit Level I menu.
	Confirm	Enter the menu interfaces level by level, and confirm the parameter setting.
	Increment	Increase data or function code.
	Decrement	Decrease data or function code.
	Shift	Select the displayed parameters in turn in the stop or running state, and select the digit to be modified when modifying parameters.
	RUN	Start the AC drive in the operation panel control mode.

Key	Name	Function
	Stop/Reset	Stop the AC drive when it is in the running state and perform the reset operation when it is in the fault state. The functions of this key are restricted in F7-02.
	Multifunction	Perform function switchover (such as quick switchover of command source or direction) according to the setting of F7-01.
	Menu mode selection	Perform switchover between menu modes according to the setting of FP-03.

4.2 Viewing and Modifying Function Codes

The operation panel of the MD380 adopts three-level menu.

The three-level menu consists of function code group (Level I), function code (Level II), and function code setting value (level III), as shown in the following figure.

Figure 4-2 Operation procedure on the operation panel

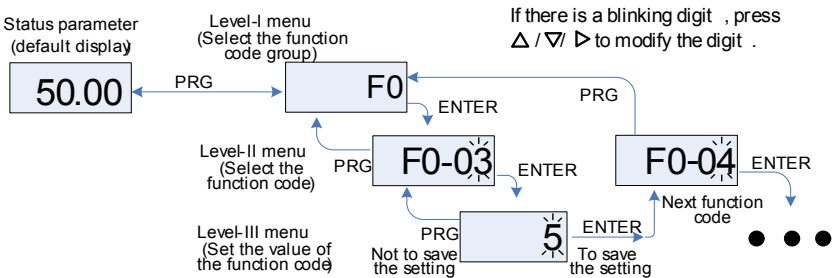

You can return to Level II menu from Level III menu by pressing or .

- After you press , the system saves the parameter setting first, and then goes back to Level II menu and shifts to the next function code.
- After you press , the system does not save the parameter setting, but directly returns to Level II menu and remains at the current function code.

Here is an example of changing the value of F3-02 to 15.00 Hz.

Figure 4-3 Example of changing the parameter value

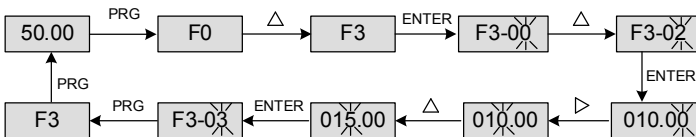

In Level III menu, if the parameter has no blinking digit, it means that the parameter cannot be modified. This may be because:

- Such a function code is only readable, such as, AC drive model, actually detected parameter and running record parameter.
- Such a function code cannot be modified in the running state and can only be changed at stop.

4.3 Structure of Function Codes

The MD380, an advanced product based on MD320, groups A and U, and new function codes to group F.

Function Code Group	Function	Description
F0 to F9, FA to FE, FP	Standard AC drive function code group	Compatible with MD320 series function codes and adding some function codes.
A0 to A8, AC	Advanced function code group	Multi-motor parameters, AI/AO correction, optimization control, PLC card extension function setting.
U0 to U3	Running state function code group	Display of AC drive basic parameters



In the function code display state, select the required function code by pressing the key  or , as shown in the following figure.

Figure 4-4 Selecting the required function code



FP-02 is used to determine whether group A and group U are displayed.

Function Code	Parameter Name	Setting Range	Default
FP-02	AC drive parameter display property	Unit's digit (group U display selection)	11
		0: Not display	
		1: Display	
		Ten's digit (group A display selection)	
		0: Not display	
		1: Display	

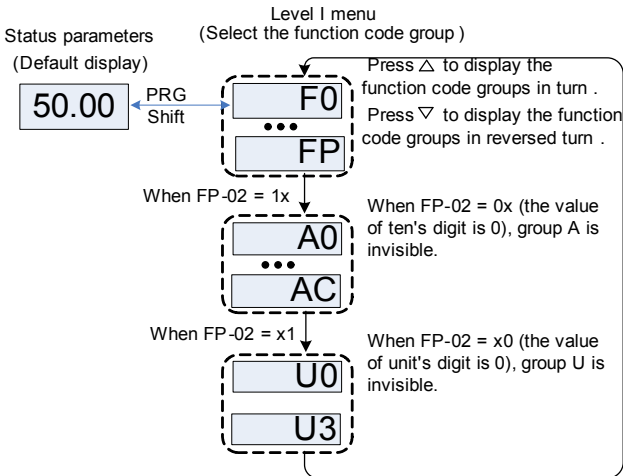
4.4 Quick View of Function Codes

The MD380 provides two quick modes of viewing the required function codes.

- 1) You can define a maximum of 30 function codes into group FE.
- 2) The MD380 automatically list the modified function codes.

In this case, the operation panel provides three viewing modes: base mode, user-defined mode and user-modified mode, as listed in the following table.

Function Code Display Mode	Display
Base mode	- b A S E
User-defined mode	- U S E r
User-modified mode	- - [- -

You can perform switchover between the three function code display modes by pressing **QUICK**. The method of viewing and modifying function codes in each mode is the same as the method of operating the operation panel described above.

Figure 4-5 Switchover between three function code display modes

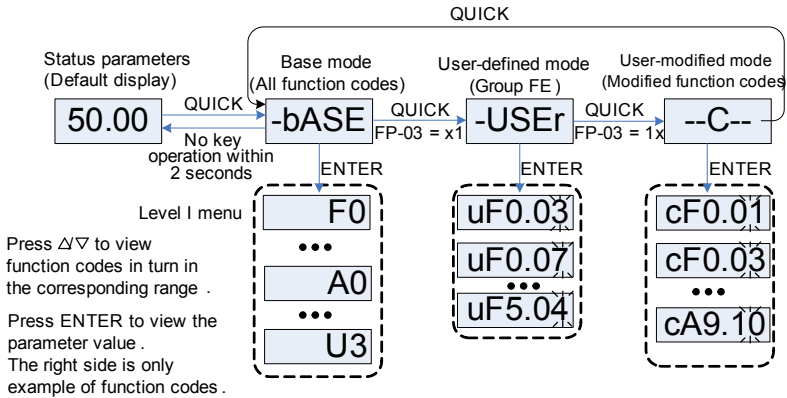

FP-03 is used to determine whether the user-defined group and user-modified group are displayed.

Function Code	Parameter Name	Setting Range	Default
FP-03	Individualized parameter display property	Unit's digit: -USEr group display selection	11
		0: Not display 1: Display	
		Ten's digit: --C-- group display selection	
		0: Not display 1: Display	

-bASE

It indicates all function codes of the MD380. After the mode is switched over to **-bASE**, level I menu is displayed.

-USEr

The user-defined menu is set to facilitate viewing and modifying of commonly used function codes. In this mode, the display parameter uF3.02 indicates function code F3-02. You can also modify parameters in this mode as in common editing state. After the mode is switched over to **-USEr**, level II menu is displayed.

The user-defined parameters are included in group FE. If FE is set to F0.00, it indicates that no function codes are available. A maximum of 30 parameters can be included in group FE. If "NULL" is displayed, it indicates that the user-defined menu is null.

A total of 16 parameters are pre-stored in the user-defined menu, as listed in the following table.

F0-01	Motor 1 control mode	F3-01	Torque boost
F0-02	Command source selection	F4-00	DI1 function selection
F0-03	Main frequency source X selection	F4-01	DI2 function selection
F0-07	Frequency source selection	F4-02	DI3 function selection
F0-08	Preset frequency	F5-04	DO1 function
F0-17	Acceleration time 1	F5-07	AO1 function selection
F0-18	Deceleration time 1	F6-00	Start mode
F3-00	V/F curve setting	F6-10	Stop mode

You can edit the user-defined menu based on actual requirements.

--C--

In you modified menu, only the parameters that are modified to a non-default value are displayed. The menu is generated by the AC drive automatically. After the mode is switched over to **--C--**, level II menu is displayed.

4.5 Definition and Operation of the Multifunction Key (MF.K)

You can define the function (command source switchover or rotation direction switchover) of the multifunction key in F7-01. For details, see the description of F7-01.

4.6 Viewing Status Parameters

In the stop or running state, you can press  on the operation panel to display status parameters. Whether parameters are displayed is determined by the binary bits of values converted from the values of F7-03, F7-04, and F7-05 in the hexadecimal format.

In stop state, a total of 13 status parameters can be displayed, as listed in the following table.

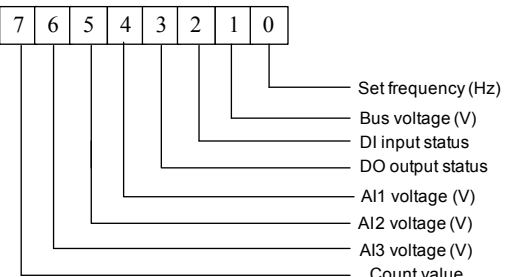
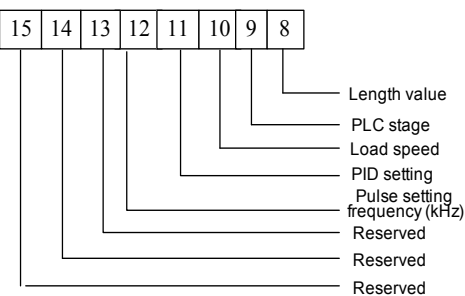
Function Code	Parameter Name	Setting Range	Default
F7-05	LED display stop parameters	0000–FFFF <div style="display: flex; justify-content: space-around; border: 1px solid black; padding: 2px;"> 76543210 </div>  <div style="display: flex; justify-content: space-around; border: 1px solid black; padding: 2px; margin-top: 10px;"> 15141312111098 </div> 	33

In running state, five running status parameters are displayed by default, and you can set whether other parameters are displayed by setting F7-03 and F7-04, as listed in the following table.

Function Code	Parameter Name	Setting Range	Default
F7-03	LED display running parameters 1	<div style="display: flex; justify-content: space-around; border: 1px solid black; padding: 2px;"> 76543210 </div> <ul style="list-style-type: none"> Running frequency1 (Hz) Set frequency (Hz) Bus voltage (V) Output voltage (V) Output current (A) Output power (kW) Output torque (%) DI input status (V) <div style="display: flex; justify-content: space-around; border: 1px solid black; padding: 2px; margin-top: 10px;"> 15141312111098 </div> <ul style="list-style-type: none"> DO output status AI1 voltage (V) AI2 voltage (V) AI3 voltage (V) Count value Length value Load speed display PID setting 	1F
F7-04	LED display running parameters 2	<div style="display: flex; justify-content: space-around; border: 1px solid black; padding: 2px;"> 76543210 </div> <ul style="list-style-type: none"> PID feedback PLC stage Pulse setting frequency(kHz) Running frequency2 Remaining running time AI1 voltage before correction AI2 voltage before correction AI3 voltage before correction <div style="display: flex; justify-content: space-around; border: 1px solid black; padding: 2px; margin-top: 10px;"> 15141312111098 </div> <ul style="list-style-type: none"> Linear speed Current power-on time (Hour) Current running time (Minute) Pulse setting frequency (Hz) Communication setting value Encoder feedback speed (Hz) Main frequency X display (Hz) Auxiliary frequency Y display (Hz) 	0

When the AC drive is powered on again after power failure, the parameters that are selected before power failure are displayed.

Select the required parameters by pressing . Set the values of the parameters by referring to the following example.

1. Determine the parameters to be displayed.

Running frequency, Bus voltage, Output voltage, Output current, Output frequency, Output torque, PID feedback, Encoder feedback speed

2. Set the binary data.

F7-03: 0000 0000 0111 1101B, F7-04: 0010 0000 0000 0001B

3. Convert the binary data to hexadecimal data:



F7-03: 007DH, F7-04: 2001H

The values displayed on the operation panel are respectively H.1043 and H.2001 respectively for F7-03 and F7-04.

4.7 Starting or Stopping the AC Drive

4.7.1 Selecting the Start/Stop Command Source

There are three start/stop command sources, namely, operation panel control, terminal control, and communication control. You can select the command source in F0-02.

Function Code	Parameter Name	Setting Range	Description	Default
F0-02	Command source selection	0: Operation panel control (indicator OFF) 1: Terminal control (indicator ON) 2: Communication control (indicator blinking)	Press  or  to start or stop the AC drive. A DI terminal needs to be defined as the run/stop terminal. The Modbus-RTU communication protocol is used.	0

- 0: Operation panel control

After you press , the AC drive starts running (the RUN indicator is ON). After you

press  when the AC drive is in running state, the AC drive stops running (the RUN indicator is OFF).

- 1: Terminal control

This control mode is applicable to scenarios where the DIP switch or electromagnetic button is used to start or stop the application system or scenarios where the dry contact signal is used to start or stop the AC drive.

The switch signal mode is set in F4-11. The input terminal of the start/stop signal is set in F4-00 to F4-09. For details, see the description of F4-11 and F4-00 to F4-09.

Example 1:

To use the DIP switch as the start/stop source, and allocate the forward rotation switch signal to DI2 and the reverse rotation switch signal to DI3, perform the setting as shown in the following figure.

Figure 4-6 Setting of using the DIP switch for start/stop

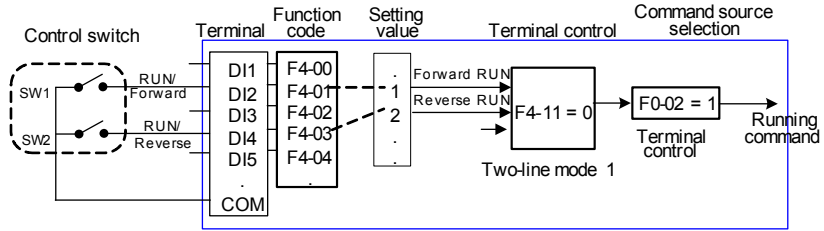

In the preceding figure, when SW1 is ON, the AC drive instructs forward rotation; when SW1 is OFF, the AC drive stops. When SW2 is ON, the AC drive instructs reverse running; when SW2 is OFF, the AC drive stops. If SW1 and SW2 are ON or OFF simultaneously, the AC drive stops.

Example 2:

To use the electromagnetic button as the start/stop source, and allocate the startup signal to DI2, stop signal to DI3 and reverse rotation signal to DI4, perform the setting as shown in the following figure.

Figure 4-7 Setting of using the electromagnetic button for start/stop

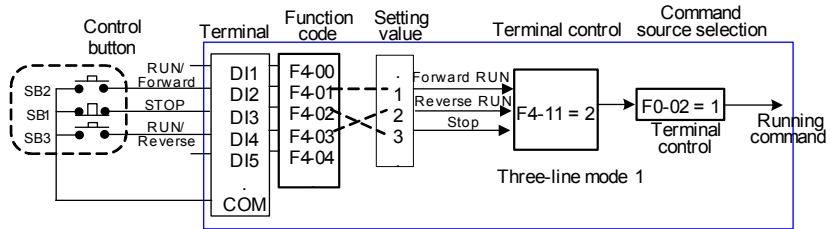

In the preceding figure, SB1 must stay ON during normal start and running. The AC drive stops immediately after SB1 becomes OFF. The signals from SB2 and SB3 become valid once they become ON. The running state of the AC drive is determined by the final actions on the three buttons.

- 2: Communication control

The most common configuration is when the host computer is used to control running of the AC drive by means of communication, such as the RS485, PROFIBUS-DP, CANlink, and CANopen. The MD380 interacts with the user programmable card also by means of communication.

Install a matching communication card in the multifunction extension port, and set F0-02 to 2. Then, you can start or stop the AC drive in communication mode. The following figure shows the setting method.

Figure 4-8 Setting for start/stop using the communication control mode

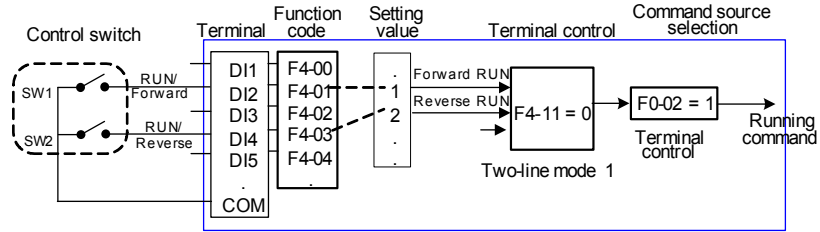

When FD-04 is set to a non-zero number, the function of automatic AC drive stop upon communication timeout is enabled. This prevents uncontrollable AC drive running due to faults of the communication cable or the host computer.

The communication port of the AC drive supports the Modbus-RTU protocol, and the communication is implemented only when the host computer supports the Modbus-RTU master station protocol.

4.7.2 Start Mode

The MD380 supports three start modes, namely, direct start, rotational speed tracking restart, and pre-excited start (asynchronous motor), set in F6-00.

- F6-00 = 0 (direct start)

It is applicable to small-inertia load. The frequency curve in this mode is shown in the following figure.

DC braking before the start is applicable to drive of load such as elevator and crane. Startup frequency is applicable to drive with burst start under start torque, such as cement mixer.

Figure 4-9 Frequency curve of direct start

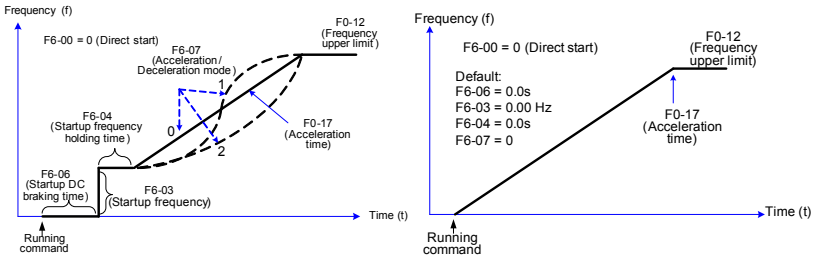

- F6-00 = 1 (Rotational speed tracking restart)

It is applicable to large-inertia load. The frequency curve in this mode is shown in the following figure. If the load motor is still rotating due to the inertia when the AC drive starts, this mode is used to prevent start overcurrent.

Figure 4-10 Frequency curve of rotational speed tracking restart

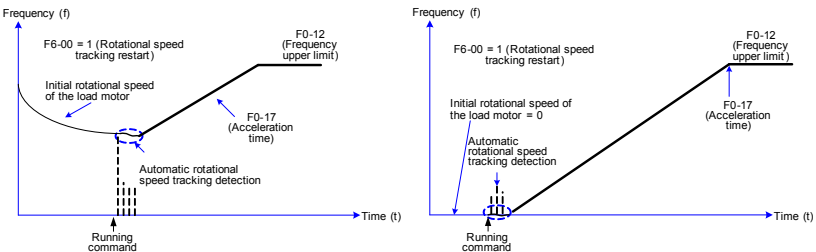

- F6-00 = 2 (Pre-excited start)

It is applicable only to inductive asynchronous motor. The AC drive performs pre-excitation before start, improving quick response of the motor and meeting the requirements of short acceleration time. The frequency curve in this mode is shown in the following figure.

Figure 4-11 Frequency curve of pre-excited start

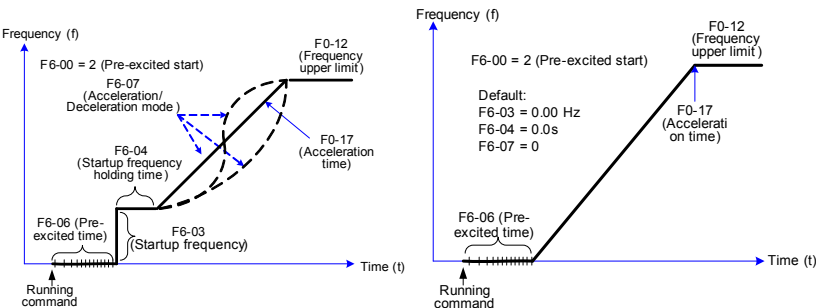

4.7.3 Stop Mode

The AC drive supports two stop modes, decelerate to stop and coast to stop, set in F6-10.

Figure 4-12 Diagram of two stop modes (decelerate to stop and coast to stop)

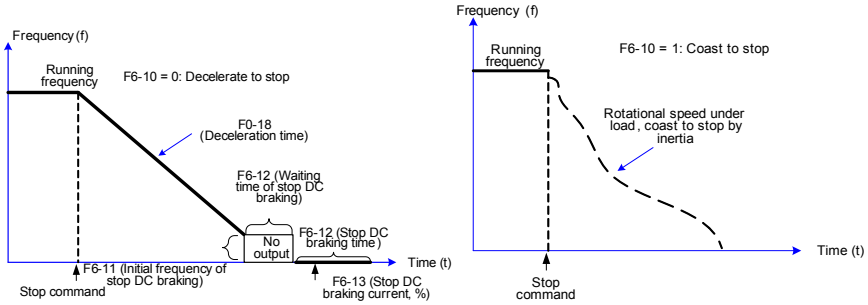

4.7.4 Timing Stop

The MD380 supports timing stop. This function is enabled by F8-42 and the timing duration is determined by F8-43 and F8-44.

Figure 4-13 Setting of the timing stop function

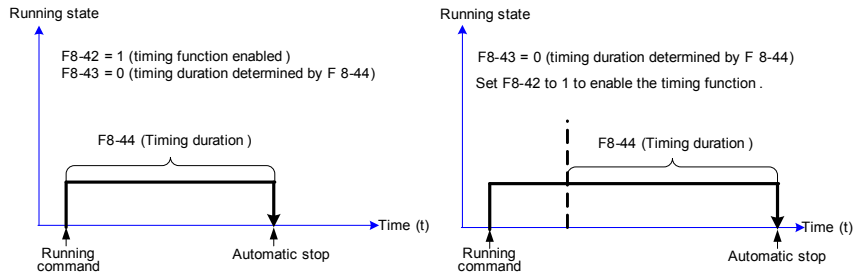

You can set the timing duration by means of analog input (such as potentiometer signal). For details, see the description of F8-43.

4.7.5 JOG Running

In certain applications, the AC drive needs to run in low speed temporarily to facilitate equipment test or other commissioning operations. In this case, you can set the AC drive to perform JOG running.

Figure 4-14 JOG running

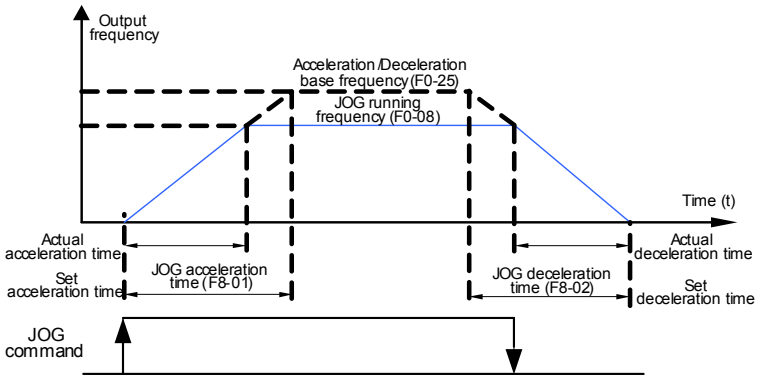

■ Parameter Setting and Operation of JOG Running in Operation Panel Control

Figure 4-15 JOG running in operation panel control

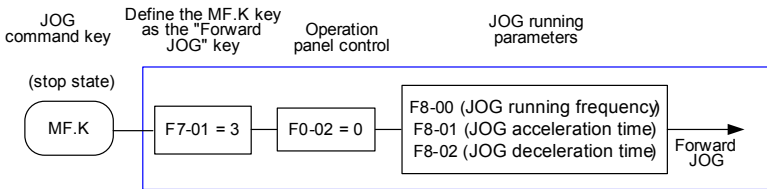

Set the parameters according to the preceding figure. In stop state of the AC drive, hold down **MF.K**, and the AC drive starts JOG running. After you release **MF.K**, the AC drive decelerates to stop.

To perform reverse JOG, set F7-01 to 4 and F8-13 to 1. Hold down **MF.K** and the AC drive starts reverse JOG running.

■ Parameter Setting and Operation of JOG Running in DI Terminal Control

For equipment that requires frequent JOG operations, such as textile machine, it is more convenient to control JOG running by using keys or buttons. To achieve convenient control, perform the setting according to the following figure.

Figure 4-16 JOG running in DI terminal control

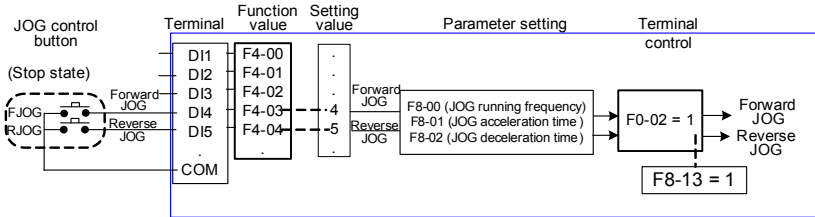

After performing the setting according to the preceding figure, press the FJOG button in stop state of the AC drive. Then, the AC drive starts forward JOG. After you press the FJOG button again, the AC drive decelerates to stop.

4.8 Setting the Running Frequency

The AC drive provides two frequency sources, namely, main frequency source X and auxiliary frequency source Y. You can select one frequency source and switch over between the two sources. You can also perform superposition on the two sources by setting the calculation formula to meet different control requirements of different scenarios.

4.8.1 Frequency Setting by the Main Frequency Source

There are nine setting modes of main frequency sources, digital setting (UP/DOWN modification, non-retentive at power failure), digital setting (UP/DOWN modification, retentive at power failure), AI1, AI2, AI3, pulse setting, multi-reference, simple PLC, and communication setting. You can select one in F0-03.

Figure 4-17 Frequency set by the main frequency source

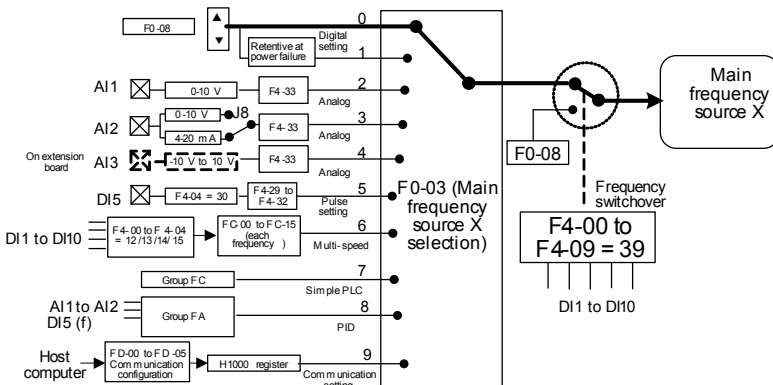

According to the preceding figure, the running frequency of the AC drive can be set by means of function codes, manual adjustment, analog input, multi-speed terminal, external feedback signal, internal PID regulator, or the host computer.

Set the corresponding function codes of each frequency setting mode, as shown in the preceding figure.

4.8.2 Frequency Setting by the Auxiliary Frequency Source

The frequency setting by the auxiliary frequency source is the same as the frequency setting by the main frequency source. You can set the auxiliary frequency source in F0-04.

Figure 4-18 Frequency set by the auxiliary frequency source

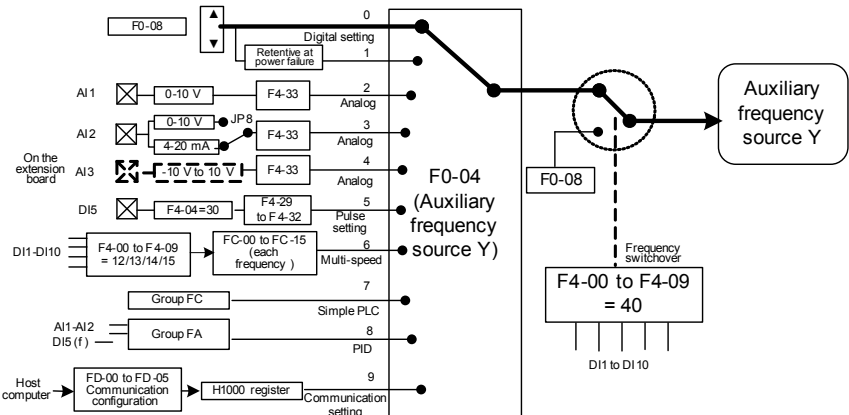

The relationship between the target running frequency and the main frequency source and auxiliary frequency source is set in F0-07, as follows:

- 1) Main frequency source X: The main frequency source is directly used to set the target running frequency.
- 2) Auxiliary frequency source Y: The auxiliary frequency source is directly used to set the target running frequency.
- 3) X and Y operation: There are four operation methods, namely, X+Y, X-Y, maximum of X and Y, and minimum of X and Y.
- 4) Frequency switchover: A DI terminal is used to switch over between the preceding three frequency setting channels.

The following figure shows how to set the relationship in F0-07, in which the bold line indicates the default setting.

Figure 4-19 Relationship between the target running frequency and main and auxiliary frequency sources

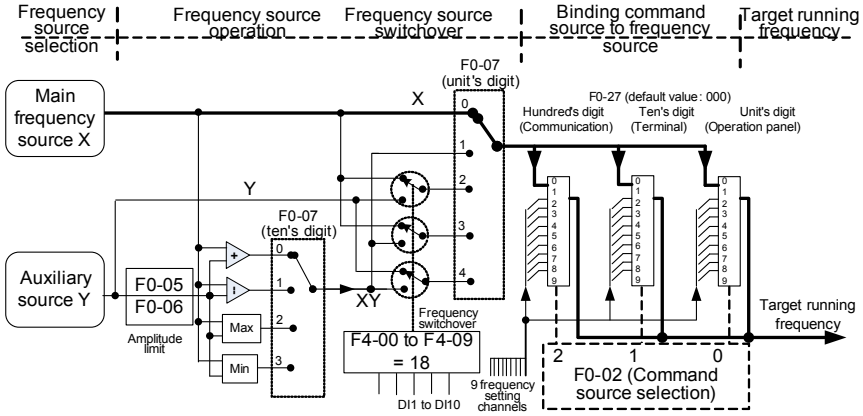

The operation between the main frequency source and the auxiliary frequency source can be used for closed-loop speed control. For example, using the main frequency source for setting the required frequency and the auxiliary frequency source for automatic adjustment, in conjunction with switchover performed by the external DI terminal signal, the required closed-loop control can be implemented.

4.8.3 Binding Command Source to Frequency Source

The three command sources can be separately bound to frequency sources, as shown in Figure 4-19. When the specified command source (F0-02) is bound to a frequency source (corresponding digit in the value of F0-27), the frequency is determined by the frequency setting channel set in F0-27. In this case, both main and auxiliary frequency sources are ineffective.

4.8.4 AI as the Frequency Source

The AI terminal can be used as the frequency source. The MD380 provides two AI terminals (AI1 and AI2) on the control board, and the optional I/O extension card provides another AI terminal (AI3).

The following figures show how to use the AI as the frequency source.

Figure 4-20 Voltage input of AI1 connected to the potentiometer as the frequency source (2–10 V corresponding to 10–40 Hz)

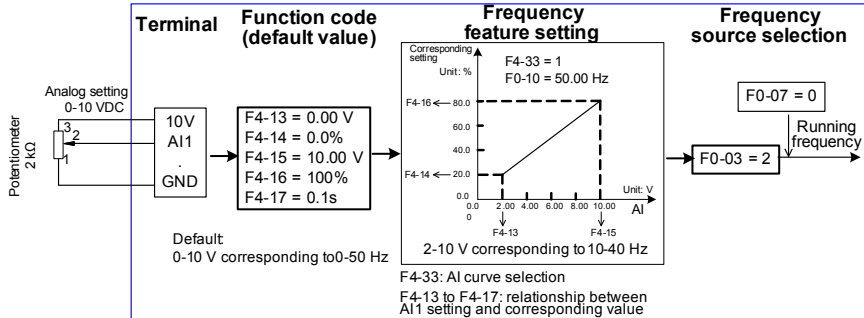
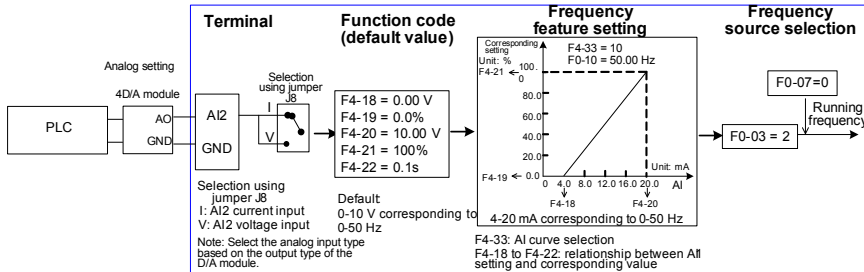

Figure 4-21 Current input of AI2 connected to 4DA module of the PLC as the frequency source (4–20 mA corresponding to 0–50 Hz)



Note

- MD380 provides two AI terminals (AI1 and AI2) on the control board, and the optional I/O extension card provides another AI terminal (AI3).
- AI1 provides 0–10 V voltage input. AI2 provides 0–10 V voltage input or 4–20 mA current input, determined by jumper J8 on the control board. AI3 provides -10 V to +10 V bipolar voltage input.
- When AI is used as the frequency source, 100% of the voltage or current input corresponding setting corresponds to the maximum frequency in F0-10.
- When the temperature transmitter is used for analog setting, it must be connected to AI3 on the I/O extension card.
- MD380 provides five corresponding relationship curves, which can be selected in F4-33. The input values and corresponding settings of each curve are set in F4-13 to F4-27 and group A6.

4.8.5 Pulse Setting as the Frequency Source

In many scenarios, pulse input is used as the frequency source. The specifications of pulse signals are: voltage 9–30 V, frequency 0–100 kHz.

Only DI5 can be used for pulse input. The relationship between pulse input from DI5 and the corresponding setting is set in F4-28 to F4-31. The relationship is a two-point line, and 100% of pulse input corresponding setting corresponds to the maximum frequency of F0-10, as shown in Figure 4-22.

Figure 4-22 Pulse setting as the frequency source

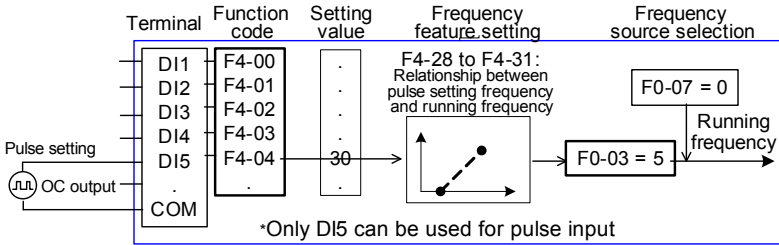

4.8.6 Frequency Closed-Loop Control

The MD380 has a built-in PID regulator. Together with the frequency sources, the PID regulator can implement automatic adjustment of progress control, such as constant temperature, constant pressure, and tension control.

Figure 4-23 Automatic adjustment by PID regulator

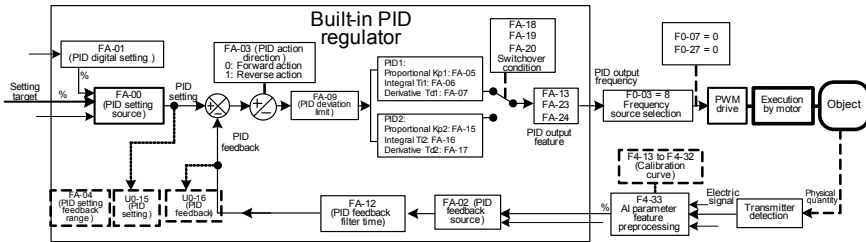

When PID frequency closed-loop control is implemented, F0-03 (Main frequency source X selection) must be set to 8 (PID). The PID-related parameters are set in group FA, as shown in Figure 4-23.

The MD380 has two built-in equivalent PID calculating units. You can set the features, such as adjustment speed and accuracy, for the two units separately based on the actual conditions. Switchover between the two units can be implemented automatically or by means of an external DI terminal.

4.8.7 Swing Mode

For the textile and chemical fiber processing equipment, the swing function improves the uniform density of traversing and winding, as shown in Figure 4-24. The function is set in FB-00 to FB-04. For details, see the description of these function codes.

Figure 4-24 Swing function

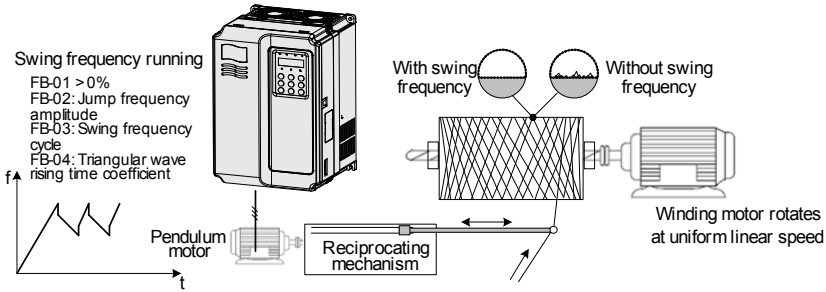

4.8.8 Multi-Speed Mode

In scenarios where the running frequency of the AC drive need not be adjusted continuously and only several frequencies are required, the multi-speed control can be used. The MD380 supports a maximum of 16 running frequencies, which are implemented by state combinations of four DI terminals. Set the function codes corresponding to DI terminals to a value among 12 to 15, and then the DI terminals are specified as the multi-frequency input terminals. The multiple frequencies are set based on the multi-frequency table in group FC. In addition, you need to set F0-03 (Main frequency source X selection) to 6 (Multi-reference). The following figure shows how to set the multi-speed function.

Figure 4-25 Setting the multi-speed function

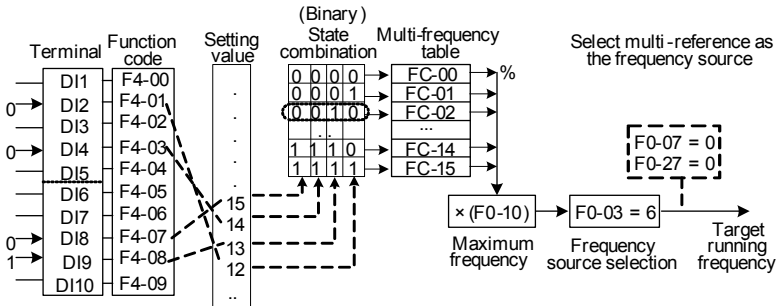

In the preceding figure, DI7, DI4, DI8, and DI2 are used as the multi-frequency input terminals, each of which has a bit value. The state combinations of these terminals correspond to multiple frequencies. When (DI7, DI4, DI8, DI2) = (0, 0, 1, 0), the state combination value is 2, corresponding to the value set in FC-02. The target running frequency is automatically calculated by FC-02 x F0-10.

The MD380 supports a maximum of four DI terminals to be used as the multi-frequency input terminals. You can also use less than four DI terminals, and the empty bit is considered to be 0.

4.8.9 Setting the Motor Rotating Direction

After the AC drive restores the default settings, press **RUN** to drive the motor to rotate. In this case, the rotating direction is regarded as the forward rotation. If the rotating direction is reverse to the direction required by the equipment, power off the AC drive and exchange any two of the output UVW cables (wait until the main capacitor of the AC drive is completely discharged).

In some applications where both forward rotation and reverse rotation are required, enable the reverse control (F8-13 = 0, default value) and meanwhile reverse the rotating direction by setting F0-09 to 1. Then press **RUN** to make the motor rotate in the reverse direction, as shown in the following figure.

Figure 4-26 Reversing the motor rotating direction

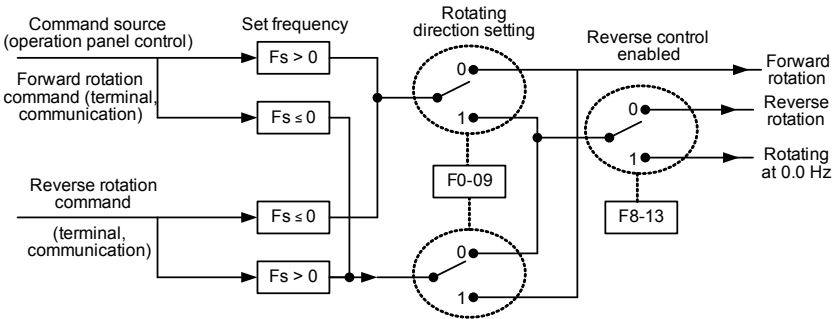

If the command source is terminal control and reverse rotation is required, use the default value 0 of F8-13 to enable reverse control.

According to the preceding figure, when the running frequency of the AC drive is set by means of communication (F0-03 = 9) and reverse control is enabled (F8-13 = 0), the AC drive instructs the reverse direction if the set frequency F_s is a negative value.

If the give running command is reverse rotation or the set frequency is a negative value, but reverse control is disabled (F8-13 = 1), the AC drive will run at 0 Hz and has no output.

In some applications where reverse rotation is prohibited, do not change the rotating direction by modifying the function codes because the function codes will be restored once the AC drive restores the default settings.

4.8.10 Setting the Fixed Length Control Mode

The MD380 has the fixed length control function. The length pulses are sampled by the DI allocated with function 27 (Length count input). The "Actual length" (FB-06) is obtained by dividing the number of pulses sampled by the value of FB-07 (Number of pulses per meter). If the actual length is larger than the "Set length" (FB-05), the multifunctional DO terminal becomes ON.

In the process of fixed length control, the length can be reset by means of the DI terminal allocated with function 28 (Length reset). The related setting is shown in the following figure.

Figure 4-27 Function code setting for fixed length control

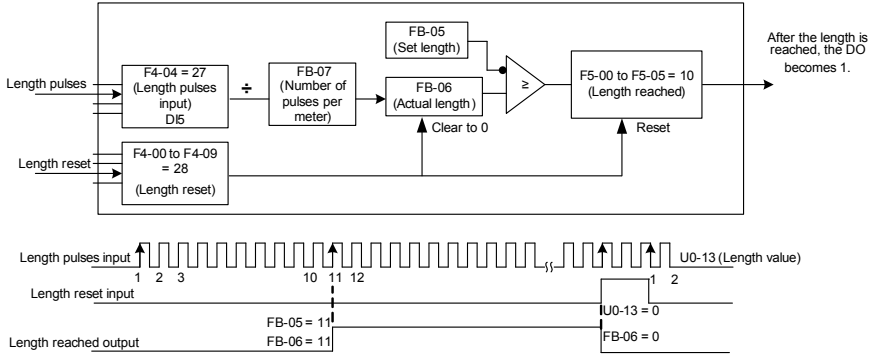

Note

- In the fixed length control mode, the direction cannot be identified and only the length shall be calculated based on the number of pulses.
- Only DI5 can be allocated with the function "Length count input".
- An automatic stop system can be implemented if the length reached signal output by the DO is fed back to the AC drive input terminal with the stop function.

Figure 4-28 Common application example of the fixed length control function

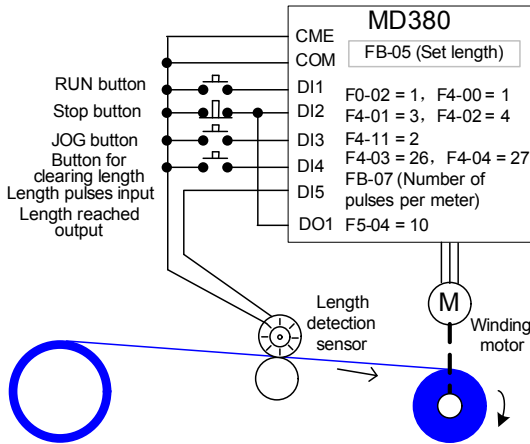

4.8.11 Use of the Counting Function

The count value needs to be collected by the DI terminal that is allocated with function 25. When the count value reaches FB-08 (Set count value), the DO terminal allocated with function 8 (Set count value reached) becomes ON. Then the counter stops counting.

When the count value reaches FB-09 (Designated count value), the DO terminal allocated with function 9 (Designated count value reached) becomes ON. The counter continues to count until "Set count value" is reached.

Figure 4-29 Parameter setting in the counting mode

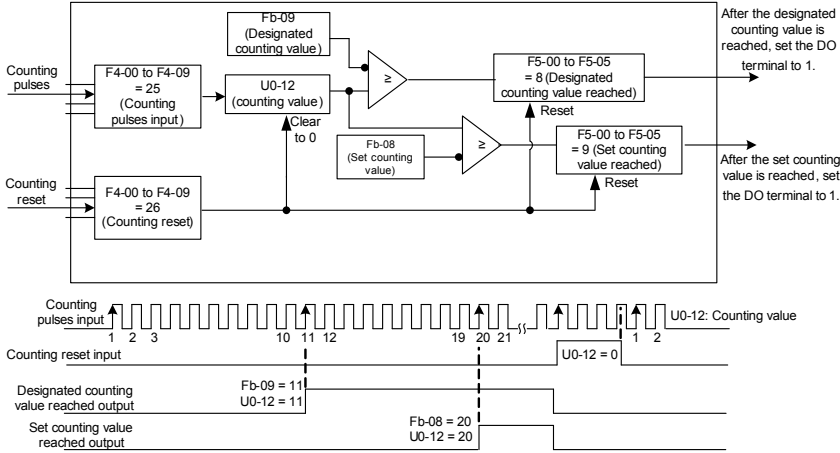

Note

- FB-09 (Designated count value) must not be greater than FB-08 (Set count value).
- DI5 must be used when the pulse frequency is high.
- The DO terminal that is allocated with function 9 (Designated count value reached) and the DO terminal that is allocated with function 8 (Set count value reached) must not be the same.
- In the RUN/STOP state of the AC drive, the counter will not stop until "Set count value" is reached.
- The count value is retentive at power failure.
- An automatic stop system can be implemented if the signal output by the DO terminal with the function (Count value reached) is fed back to the DI terminal of the AC drive with stop function.

4.9 Setting and Auto-tuning of Motor Parameters

4.9.1 Motor Parameters to Be Set

When the AC drive runs in the vector control mode (F0-01 = 0 or 1), accurate motor parameters are required to ensure desired driver performance and running efficiency. This is extremely different from the V/F control (F0-01 = 2).

Motor parameters (motor 1 by default) that need to be set are listed in the following table.

Table 4-2 Motor parameters to be set

Parameter	Description	Remark
F1-00	Motor type	Asynchronous motor, variable-frequency asynchronous motor, synchronous motor
F1-01 to F1-05	Rated motor power, Rated motor voltage, Rated motor current, Rated motor frequency, Rated motor rotational speed	Model parameters, manual input
F1-06 to F1-20	Motor internal equivalent stator resistance, inductive reactance and rotor inductance	Auto-tuning parameters
F1-27/28/34	Encoder parameters (these parameters need to be set in the vector control mode with sensor)	Encoder parameters

For complicated application system with multiple motors, the parameters of motors 2, 3, and 4 are listed in the following table.

Table 4-3 Motors 2, 3, and 4 parameters to be set

Motor 2 Parameters	Motor 3 Parameters	Motor 4 Parameters	Description
A2-00	A3-00	A4-00	Asynchronous motor, variable-frequency asynchronous motor, synchronous motor
A2-01 to A2-05	A3-01 to A3-05	A4-01 to A4-05	Model parameters, manual input
A2-06 to A2-20	A3-06 to A3-20	A4-06 to A4-20	Auto-tuning parameters
A2-27, A2-28, A2-34	A3-27, A3-28, A3-34	A4-27, A4-28, A4-34	Encoder parameters

4.9.2 Motor Auto-tuning

To obtain the motor parameters, the AC drive can perform dynamic auto-tuning or static auto-tuning. For the asynchronous motor that cannot be disconnected from the load, you can input the motor parameters of the same model that was successfully auto-tuned before.

Auto-tuning	Application	Result
No-load dynamic auto-tuning	It is applied to applications where the motor (synchronous motor or asynchronous motor) can be disconnected from the load.	Best
With-load dynamic auto-tuning	It is applied to applications where the motor (synchronous motor or asynchronous motor) cannot be disconnected from the load.	OK
Static auto-tuning	It is applied to applications where the motor (asynchronous motor only) cannot be disconnected from the load and dynamic auto-tuning is not allowed.	Poor
Manual input	It is applied to applications where the motor (asynchronous motor only) cannot be disconnected from the load. Input the motor parameters of the same model that was successfully auto-tuned before into function codes F1-00 to F1-10.	OK

The following motor auto-tuning description takes motor 1 as an example. The auto-tuning of motor 2, 3, and 4 is the same and only the function codes are changed correspondingly.

The process of motor auto-tuning is as follows:

- 1) If the motor can be disconnected from the load, disconnect the motor from the load mechanically after power-off so that the motor can run without load.
- 2) After power-on, set F0-02 (Command source selection) to 0 (Operation panel control).
- 3) Input the motor nameplate parameters (such as F1-00 to F1-05) correctly and input the following parameters based on the actually selected motor.

Motor	Parameter
Motor 1	F1-00: Motor type selection F1-01: Rated motor power F1-02: Rated motor voltage F1-03: Rated motor current F1-04: Rated motor frequency F1-05: Rated motor rotational speed
Motor 2	A2-00 to A2-05, defined the same as F1-00 to F1-05
Motor3	A3-00 to A3-05, defined the same as F1-00 to F1-05
Motor 4	A4-00 to A4-05, defined the same as F1-00 to F1-05

For asynchronous motor, set F1-37 (Auto-tuning selection) to 2 (Asynchronous motor complete auto-tuning). For motors 2, 3, or 4, the corresponding function code is A2-37/ A3-37/ A4-37. Press  on the operation panel. The operation panel displays:

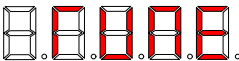

Then press  on the operation panel. The AC drive will drive the motor to accelerate/ decelerate and run in the forward/reverse direction, and the RUN indicator is ON. The auto-tuning lasts approximately 2 minutes. When the preceding display information disappears and the operation panel returns to the normal parameter display status, it indicates that the auto-tuning is complete.

The AC drive will automatically calculate the following motor parameters:

Motor	Parameter
Motor 1	F1-06: Stator resistance (asynchronous motor) F1-07: Rotor resistance (asynchronous motor) F1-08: Leakage inductive reactance (asynchronous motor) F1-09: Mutual inductive reactance (asynchronous motor) F1-10: No-load current (asynchronous motor)
Motor 2	A2-06 to A2-10, defined the same as F1-06 to F1-10
Motor3	A3-06 to A3-10, defined the same as F1-06 to F1-10
Motor 4	A4-06 to A4-10, defined the same as F1-06 to F1-10

If the motor cannot be disconnected from the load, set F1-37 (Auto-tuning selection) to 1 (Asynchronous motor static tuning) and then press  on the operation panel. The motor auto-tuning starts.

Note

In the synchronous motor system driven by MD380, and encoder for signal feedback is required. Therefore, you need to set the encoder parameters correctly before the auto-tuning. During the synchronous motor auto-tuning, the synchronous motor must rotate, and the best auto-tuning mode is no-load dynamic auto-tuning. If it is not allowed, you can perform with-load dynamic auto-tuning.

4.9.3 Setting and Switchover of Multiple Groups of Motor Parameters

The AC drive supports switchover between four groups of motor parameters, namely, groups F1, F2 (motor 1 parameters and encoder parameters) and group A2 (motor 2 parameters), group A3 (motor 3 parameters) and group A4 (motor 4 parameters).

You can select the current effective motor parameter group by means of function code F0-24 or DI terminals with functions 41 and 42. When the DI terminals with functions 41 and 42 become ON, they are privileged and the setting of F0-24 becomes invalid.

Figure 4-30 Driving multiple motors

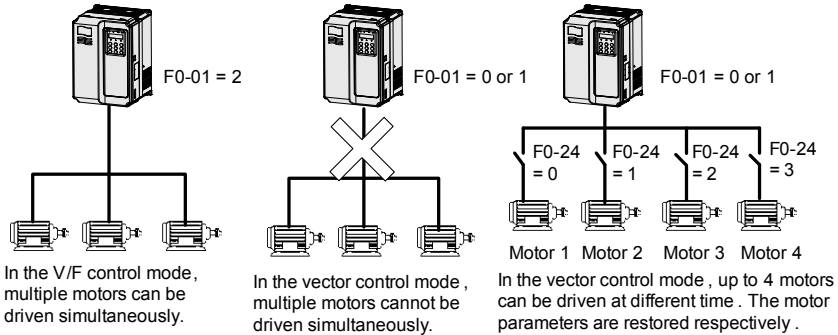

4.10 Use of DI Terminals

The control board provides five DI terminals DI1 to DI5. You can obtain another DI terminals DI6 to DI10 by installing an I/O extension card.

The internal hardware of DI terminals are configured with 24 VDC power supply for detection. You can input a signal to a DI terminal of the AC drive only by shorting the DI terminal and COM.

By default, F4-38 = 0000 and F4-39 = 0000. When a DI terminal is shorted to COM, it is active (logic 1). When a DI terminal is not shorted to COM, it is inactive (logic 0).

You can change the DI terminal active mode. That is, a DI terminal is inactive (logic 0) when being shorted with COM, and active (logic 1) when being not shorted to COM. In this case, it is necessary to change the corresponding bit in F4-38 and F4-39 (these two parameters respectively specifying the active mode setting of DI1 to DI5 and DI16 to DI10) to 1.

The AC drive also provides F4-10 (DI filter time) for the DI signal to improve the anti-interference level. For DI1 to DI3, the AC drive provides the DI signal delay function, convenient for some applications requiring delay.

Figure 4-31 DI delay setting

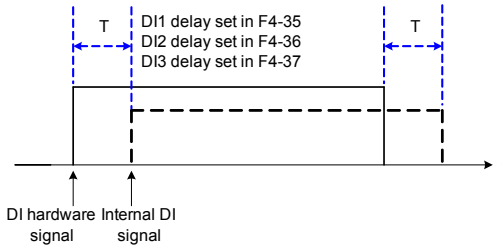

The preceding 10 DI terminals can be defined in function codes F4-00 to F4-09. Each DI can be allocated with their respective function from the 50 functions. For details, see descriptions of F4-00 to F4-09.

The hardware design allows only DI5 to receive high-speed pulse signal. If high-speed pulse count is required, use DI5.

4.11 Use of DO Terminals

The control board provides three DO terminals, namely FM, DO1 and TA/TB/TC. FM and DO1 are transistor outputs and can drive 24 VDC low-voltage circuit; TA/TB/TC is relay output, and can drive 250 VAC control circuit.

You can obtain another two terminals DO2 and PA/PB/PC by installing an I/O extension card. DO2 is transistor output and PA/PB/PC is relay output.

You can define the function of the DO terminals by setting F5-01 and F5-05 to indicate the running state and alarm information of the AC drive. There are a total of 40 functions. For details, see the descriptions of group F5.

Terminal	Corresponding Function Code	Output Feature Description
FM-CME	F5-06 when F5-00 = 0	Transistor, able to output high-speed pulses 10 Hz to 100 kHz; drive capacity: 24 VDC, 50 mA
	F5-01 when F5-00 = 1	Transistor; drive capacity: 24 VDC, 50 mA
TA-TB-TC	F5-02	Relay; drive capacity: 250 VAC, 3 A
PA-PB-PC	F5-03	Extension card, relay; drive capacity: 250 VAC, 3 A
DO1-CME	F5-04	Transistor; drive capacity: 24 VDC, 50 mA
DO2-CME	F5-05	Extension card, transistor; drive capacity: 24 VDC, 50 mA

When F5-00 = 0, the FM terminal is high-speed pulse output. The frequency of output pulses indicates the value of the internal running parameters. The greater the value is, the higher the output pulse frequency is. The 100% value corresponds to 100 kHz. The property of the indicated internal parameter is defined by F5-06.

4.12 Use of AI Terminals

The AC drive supports a total of three AI terminals, among which AI1 and AI2 are provided on the control board and AI3 is provided on the extension card.

Terminal	Input Signal Characteristic
AI1-GND	It receives the signal of 0–10 VDC.
AI2-GND	If J8 is connected to the position with "V" mark, it receives the signal of 0–10 VDC. If J8 is connected to the position with "I" mark, it receives the signal of 4–20 mA.
AI3-GND	It is provided on the extension card and receives the signal of -10 to +10 VDC.

As external voltage/current signal, AI is used for frequency source setting, torque setting, voltage setting at V/F separation, and PID setting or feedback. The corresponding relationship of the voltage or current and actual setting or feedback is defined by F4-13 to F4-27.

Figure 4-32 Defining corresponding relationship of the voltage or current and actual setting or feedback

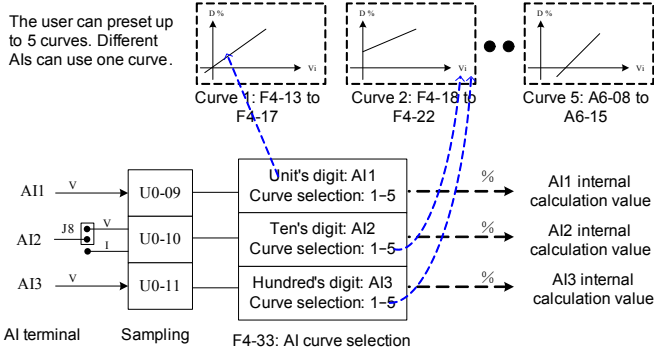

The sampling of AI terminals can be queried in U0-09 to U0-11. The calculation value is for internal subsequent calculation and cannot be directly read by the user.

4.13 Use of AO Terminals

The AC drive supports a total of two AO terminals, among which AO1 is provided by the control board and AO2 is provided on the extension card.

Terminal	Output Signal Characteristic
AO1-GND	If J5 is connected to the position with "V" mark, it outputs the signal of 0–10 VDC. If J5 is connected to the position with "I" mark, it outputs the signal of 0–20 mA.
AO2-GND	It is provided on the extension card and outputs the signal of 0–10 VDC.

AO1 and AO2 can be used to indicate the internal running parameters in the analog mode. The property of indicated parameters can be defined by F5-07 and F5-08.

The designated running parameters can be rectified before output. The rectification feature is $Y = kX + b$, among which "X" indicates the running parameters to be output, and "k" and "b" of AO1 can be set by F5-10 and F5-11.

Figure 4-33 Setting of "k" and "b" of AO1

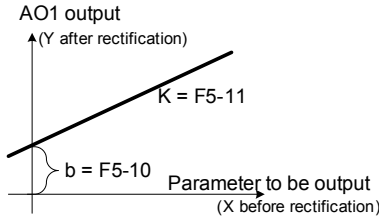

4.14 Use of the PG Terminal

The closed-loop vector control with sensor (F0-01 = 1) helps to improve the speed stability accuracy of the AC drive. In this case, it is necessary to install an encoder for the motor. Signals from the encoder are fed back to the AC drive through the PG card. The MD380 provides PG cards of four different types of signal features.

The AC drive supports four types of encoders, differential encoder, UVW encoder (wire-saving UVW encoder), resolver, open-collector encoder.

The setting of encoder parameters varies with the actually used encoder type. Here takes motor 1 parameters as an example for description.

- For the differential encoder, set F1-27 (Encoder pulses per revolution) and set F1-28 to 0 (ABZ incremental encoder).
- For the UVW encoder, set F1-27 (Encoder pulses per revolution) and set F1-28 to 1 (UVW incremental encoder).
- For the resolver, set F1-28 to 2 (Resolver).
- For the open-collector encoder, set F1-27 (Encoder pulses per revolution) and set F1-28 to 0 (ABZ incremental encoder).
- For the wire-saving UVW encoder, set F1-27 (Encoder pulses per revolution) and set F1-28 to 4 (Wire-saving UVW encoder).

4.15 Use of Serial Communication

When communication mode RS485, Profibus-DP or CANopen are adopted, you need to install a corresponding extension card on the MD380 series AC drive, and set F0-28 correctly according to the used communication protocol type. CAN-link is enabled by default and you need not select it.

For the configuration of hardware communication parameters for the communication port, see group FD. Set the communication rate and data format to consistent with those of the host computer, which is the precondition of normal communication.

The MD380 serial port itself supports the Modbus RTU slave communication protocol. You can query or modify the AC drive's function codes, query various running state parameters, and send running command and running frequency to the AC drive from the host computer through the serial port.

Figure 4-34 Communication control mode of the AC drive

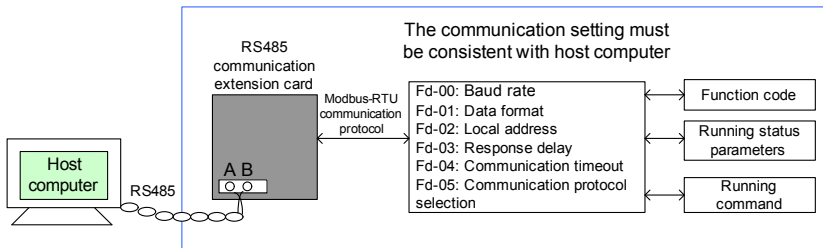

The MD380 arranges the function codes, running state parameters and running commands in the "register parameter address" mode. The host computer can define the protocol of communication data interaction.

4.16 Use of Multifunctional Extension Interfaces

The extension card and functions are described in the following table.

Table 4-4 Extension cards and functions

Name	Model	Function	Remark
I/O extension card 1	MD38IO1	It extends five DIs, an analog voltage input AI3 (isolation analog) connected to PT100, PT1000, a relay output, a DO, and an AO. It supports RS485 and CAN protocols.	Applied to the models of 3.7 kW and above.
I/O extension card 2-Size B	MD38IO2	It extends three DI terminals.	Applied to all models.
Modbus communication card	MD38TX1	RS485 communication card with isolation	Applied to all models.
CANlink communication extension card	MD38CAN1	CANlink communication card	Applied to all models.
CANopen communication extension card	MD38CAN2	CANopen communication card	Applied to all models.
Profibus-DP communication card	MD38DP	Profibus-DP communication card	Applied to the models of 3.7 kW and above.
User programmable card	MD38PC1	User programmable extension card, completely compatible with Inovance's H1U series PLC	Applied to the models of 3.7 kW and above.
Differential encoder interface card	MD38PG1	Differential encoder interface card, requiring 5 V power supply	Applied to all models.
UVW encoder interface card	MD38PG3	Applied to UVW differential encoder and used on PMSM, requiring 5 V power supply	Applied to all models.
Resolver interface card	MD38PG4	Applied to resolver, excitation frequency 10 kHz, DB9 interface	Applied to all models.
Open-collector encoder card	MD38PG5	Open-collector encoder card, requiring 15 V power supply	Applied to all models.

4.17 Password Setting

The AC drive provides the user password protection function. When FP-00 is set to a non-zero value, the value is the user password. The password takes effect after you after exit the function code editing state. When you press **PRG** again, "-----" will be displayed, and you must enter the correct user password to enter the menu.

To cancel the password protection function, enter with password and set FP-00 to 0.

4.18 Parameter Saving and Default Setting Restoring

After a function code is modified on the operation panel, the modification will be saved in the register of the AC drive and remain effective at next power-on.

The AC drive supports backup and restoration of parameter setting, which is convenient for commissioning.

The AC drive also provides the retentive function on alarm information and accumulative running time.

You can restore the backup values or default settings of the function codes of the AC drive or clear the running data through FP-01. For details, see the description of FP-01.

Figure 4-35 Parameter saving and default parameter restoring

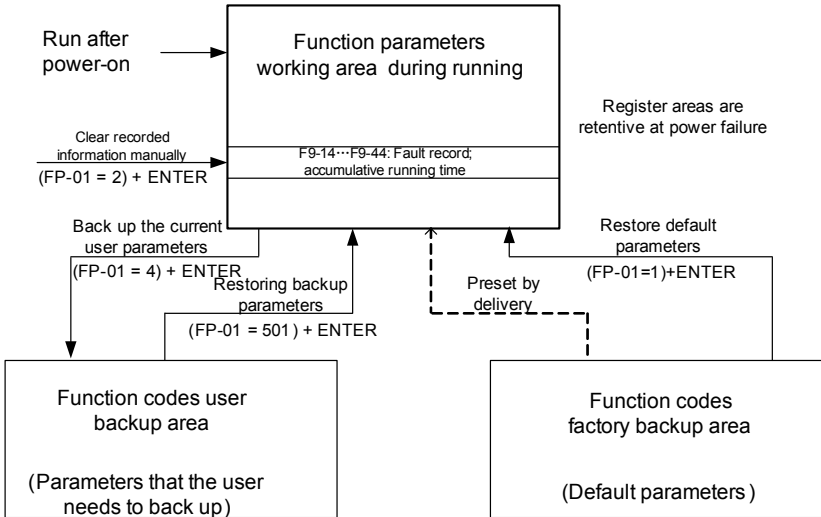



Function Code Table

Chapter 5 Function Code Table

If FP-00 is set to a non-zero number, parameter protection is enabled. You must enter the correct user password to enter the menu.

To cancel the password protection function, enter with password and set FP-00 to 0.

Group F and Group A are standard function parameters. Group U includes the monitoring function parameters.

The symbols in the function code table are described as follows:

"☆": The parameter can be modified when the AC drive is in either stop or running state.

"★": The parameter cannot be modified when the AC drive is in the running state.

"●": The parameter is the actually measured value and cannot be modified.

"*": The parameter is factory parameter and can be set only by the manufacturer.

5.1 Standard Function Parameters

Function Code	Parameter Name	Setting Range	Default	Property
Group F0: Standard Function Parameters				
F0-00	G/P type display	1: G type (constant torque load) 2: P type (variable torque load e.g. fan and pump)	Model dependent	●
F0-01	Motor 1 control mode	0: Sensorless flux vector control (SFVC) 1: Closed-loop vector control (CLVC) 2: Voltage/Frequency (V/F) control	0	★
F0-02	Command source selection	0: Operation panel control (LED off) 1: Terminal control (LED on) 2: Communication control (LED blinking)	0	☆
F0-03	Main frequency source X selection	0: Digital setting (non-retentive at power failure) 1: Digital setting (retentive at power failure) 2: AI1 3: AI2 4: AI3	0	★

Function Code	Parameter Name	Setting Range	Default	Property
F0-03	Main frequency source X selection	5: Pulse setting (DI5) 6: Multi-reference 7: Simple PLC 8: PID 9: Communication setting	0	★
F0-04	Auxiliary frequency source Y selection	The same as F0-03 (Main frequency source X selection)	0	★
F0-05	Range of auxiliary frequency Y for X and Y operation	0: Relative to maximum frequency 1: Relative to main frequency X	0	☆
F0-06	Range of auxiliary frequency Y for X and Y operation	0%–150%	100%	☆
F0-07	Frequency source selection	Unit's digit (Frequency source selection)	00	☆
		0: Main frequency source X 1: X and Y operation (operation relationship determined by ten's digit) 2: Switchover between X and Y 3: Switchover between X and "X and Y operation" 4: Switchover between Y and "X and Y operation"		
		Ten's digit (X and Y operation relationship)		
		0: X+Y 1: X-Y 2: Maximum 3: Minimum		
F0-08	Preset frequency	0.00 to maximum frequency (valid when frequency source is digital setting)	50.00 Hz	☆
F0-09	Rotation direction	0: Same direction 1: Reverse direction	0	☆
F0-10	Maximum frequency	50.00–320.00 Hz	50.00 Hz	★
F0-11	Source of frequency upper limit	0: Set by F0-12 1: AI1 2: AI2 3: AI3 4: Pulse setting (DI5) 5: Communication setting	0	★

Function Code	Parameter Name	Setting Range	Default	Property
F0-12	Frequency upper limit	Frequency lower limit (F0-14) to maximum frequency (F0-10)	50.00 Hz	☆
F0-13	Frequency upper limit offset	0.00 Hz to maximum frequency (F0-10)	0.00 Hz	☆
F0-14	Frequency lower limit	0.00 Hz to frequency upper limit (F0-12)	0.00 Hz	☆
F0-15	Carrier frequency	0.5–16.0 kHz	Model dependent	☆
F0-16	Carrier frequency adjustment with temperature	0: No 1: Yes	1	☆
F0-17	Acceleration time 1	0.00–650.00s (F0-19 = 2) 0.0–6500.0s (F0-19 = 1) 0–65000s (F0-19 = 0)	Model dependent	☆
F0-18	Deceleration time 1	0.00–650.00s (F0-19 = 2) 0.0–6500.0s (F0-19 = 1) 0–65000s (F0-19 = 0)	Model dependent	☆
F0-19	Acceleration/Deceleration time unit	0:1s 1: 0.1s 2: 0.01s	1	★
F0-21	Frequency offset of auxiliary frequency source for X and Y operation	0.00 Hz to maximum frequency (F0-10)	0.00 Hz	☆
F0-22	Frequency reference resolution	1: 0.1 Hz 2: 0.01 Hz	2	★
F0-23	Retentive of digital setting frequency upon power failure	0: Not retentive 1: Retentive	2	☆
F0-24	Motor parameter group selection	0: Motor parameter group 1 1: Motor parameter group 2 2: Motor parameter group 3 3: Motor parameter group 4	0	★
F0-25	Acceleration/Deceleration time base frequency	0: Maximum frequency (F0-10) 1: Set frequency 2: 100 Hz	0	★
F0-26	Base frequency for UP/DOWN modification during running	0: Running frequency 1: Set frequency	0	★

Function Code	Parameter Name	Setting Range	Default	Property
F0-27	Binding command source to frequency source	Unit's digit (Binding operation panel command to frequency source)	000	☆
		0: No binding 1: Frequency source by digital setting 2: AI1 3: AI2 4: AI3 5: Pulse setting (DI5) 6: Multi-reference 7: Simple PLC 8: PID 9: Communication setting		
		Ten's digit (Binding terminal command to frequency source)		
		0-9, same as unit's digit		
		Hundred's digit (Binding communication command to frequency source)		
		0-9, same as unit's digit		
F0-28	Serial communication protocol	0: Modbus protocol 1: Profibus-DP bridge 2: CANopen bridge	0	☆
Group F1: Motor 1 Parameters				
F1-00	Motor type selection	0: Common asynchronous motor 1: Variable frequency asynchronous motor 2: Permanent magnetic synchronous motor	1	★
F1-01	Rated motor power	0.1-1000.0 kW	Model dependent	★
F1-02	Rated motor voltage	1-2000 V	Model dependent	★
F1-03	Rated motor current	0.01-655.35 A (AC drive power ≤ 55 kW) 0.1-6553.5 A (AC drive power > 55 kW)	Model dependent	★
F1-04	Rated motor frequency	0.01 Hz to maximum frequency	Model dependent	★
F1-05	Rated motor rotational speed	1-65535 RPM	Model dependent	★

Function Code	Parameter Name	Setting Range	Default	Property
F1-06	Stator resistance (asynchronous motor)	0.001–65.535 Ω (AC drive power ≤ 55 kW) 0.0001–6.5535 Ω (AC drive power > 55 kW)	Model dependent	★
F1-07	Rotor resistance (asynchronous motor)	0.001–65.535 Ω (AC drive power ≤ 55 kW) 0.0001–6.5535 Ω (AC drive power > 55 kW)	Model dependent	★
F1-08	Leakage inductive reactance (asynchronous motor)	0.01–655.35 mH (AC drive power ≤ 55 kW) 0.001–65.535 mH (AC drive power > 55 kW)	Model dependent	★
F1-09	Mutual inductive reactance (asynchronous motor)	0.1–6553.5 mH (AC drive power ≤ 55 kW) 0.01–655.35 mH (AC drive power > 55 kW)	Model dependent	★
F1-10	No-load current (asynchronous motor)	0.01 to F1-03 (AC drive power ≤ 55 kW) 0.1 to F1-03 (AC drive power > 55 kW)	Model dependent	★
F1-16	Stator resistance (synchronous motor)	0.001–65.535 Ω (AC drive power ≤ 55 kW) 0.0001–6.5535 Ω (AC drive power > 55 kW)	Model dependent	★
F1-17	Shaft D inductance (synchronous motor)	0.01–655.35 mH (AC drive power ≤ 55 kW) 0.001–65.535 mH (AC drive power > 55 kW)	Model dependent	★
F1-18	Shaft Q inductance (synchronous motor)	0.01–655.35 mH (AC drive power ≤ 55 kW) 0.001–65.535 mH (AC drive power > 55 kW)	Model dependent	★
F1-20	Back EMF (synchronous motor)	0.1–6553.5 V	Model dependent	★
F1-27	Encoder pulses per revolution	1–65535	1024	★
F1-28	Encoder type	0: ABZ incremental encoder 1: UVW incremental encoder 2: Resolver 3: SIN/COS encoder 4: Wire-saving UVW encoder	0	★
F1-30	A/B phase sequence of ABZ incremental encoder	0: Forward 1: Reserve	0	★

Function Code	Parameter Name	Setting Range	Default	Property
F1-31	Encoder installation angle	0.0°–359.9°	0.0°	★
F1-32	U, V, W phase sequence of UVW encoder	0: Forward 1: Reverse	0	★
F1-33	UVW encoder angle offset	0.0°–359.9°	0.0°	★
F1-34	Number of pole pairs of resolver	1–65535	1	★
F1-36	Encoder wire-break fault detection time	0.0s: No action 0.1–10.0s	0.0s	★
F1-37	Auto-tuning selection	0: No auto-tuning 1: Asynchronous motor static auto-tuning 2: Asynchronous motor complete auto-tuning 11: Synchronous motor with-load auto-tuning 12: Synchronous motor no-load auto-tuning	0	★
Group F2: Vector Control Parameters				
F2-00	Speed loop proportional gain 1	0–100	30	☆
F2-01	Speed loop integral time 1	0.01–10.00s	0.50s	☆
F2-02	Switchover frequency 1	0.00 to F2-05	5.00 Hz	☆
F2-03	Speed loop proportional gain 2	0–100	20	☆
F2-04	Speed loop integral time 2	0.01–10.00s	1.00s	☆
F2-05	Switchover frequency 2	F2-02 to maximum output frequency	10.00 Hz	☆
F2-06	Vector control slip gain	50%–200%	100%	☆
F2-07	Time constant of speed loop filter	0.000–0.100s	0.000s	☆
F2-08	Vector control over-excitation gain	0–200	64	☆
F2-09	Torque upper limit source in speed control mode	0: F2-10 1: AI1 2: AI2 3: AI3 4: Pulse setting (DI5) 5: Communication setting	0	☆
F2-10	Digital setting of torque upper limit in speed control mode	0.0%–200.0%	150.0%	☆

Function Code	Parameter Name	Setting Range	Default	Property
F2-13	Excitation adjustment proportional gain	0–20000	2000	☆
F2-14	Excitation adjustment integral gain	0–20000	1300	☆
F2-15	Torque adjustment proportional gain	0–20000	2000	☆
F2-16	Torque adjustment integral gain	0–20000	1300	☆
F2-17	Speed loop integral property	Unit's digit: integral separation 0: Disabled 1: Enabled	0	☆
F2-18	Field weakening mode of synchronous motor	0: No field weakening 1: Direct calculation 2: Automatic adjustment	1	☆
F2-19	Field weakening depth of synchronous motor	50%–500%	100%	☆
F2-20	Maximum field weakening current	1%–300%	50%	☆
F2-21	Field weakening automatic adjustment gain	10%–500%	100%	☆
F2-22	Field weakening integral multiple	2–10	2	☆
Group F3: V/F Control Parameters				
F3-00	V/F curve setting	0: Linear V/F 1: Multi-point V/F 2: Square V/F 3: 1.2-power V/F 4: 1.4-power V/F 6: 1.6-power V/F 8: 1.8-power V/F 9: Reserved 10: V/F complete separation 11: V/F half separation	0	★
F3-01	Torque boost	0.0% (fixed torque boost) 0.1%–30.0%	Model dependent	☆
F3-02	Cut-off frequency of torque boost	0.00 Hz to maximum output frequency	50.00 Hz	★
F3-03	Multi-point V/F frequency 1 (F1)	0.00 Hz to F3-05	0.00 Hz	★
F3-04	Multi-point V/F voltage 1 (V1)	0.0%–100.0%	0.0%	★

Function Code	Parameter Name	Setting Range	Default	Property
F3-05	Multi-point V/F frequency 2 (F2)	F3-03 to F3-07	0.00 Hz	★
F3-06	Multi-point V/F voltage 2 (V2)	0.0%–100.0%	0.0%	★
F3-07	Multi-point V/F frequency 3 (F3)	F3-05 to rated motor frequency (F1-04) Note: The rated frequencies of motors 2, 3, and 4 are respectively set in A2-04, A3-04, and A4-04.	0.00 Hz	★
F3-08	Multi-point V/F voltage 3 (V3)	0.0%–100.0%	0.0%	★
F3-09	V/F slip compensation gain	0%–200.0%	0.0%	☆
F3-10	V/F over-excitation gain	0–200	64	☆
F3-11	V/F oscillation suppression gain	0–100	Model dependent	☆
F3-13	Voltage source for V/F separation	0: Digital setting (F3-14) 1: AI1 2: AI2 3: AI3 4: Pulse setting (DI5) 5: Multi-reference 6: Simple PLC 7: PID 8: Communication setting 100.0% corresponds to the rated motor voltage (F1-02, A4-02, A5-02, A6-02).	0	☆
F3-14	Voltage digital setting for V/F separation	0 V to rated motor voltage	0 V	☆
F3-15	Voltage rise time of V/F separation	0.0–1000.0s It indicates the time for the voltage rising from 0 V to rated motor voltage.	0.0s	☆
F3-16	Voltage decline time of V/F separation	0.0–1000.0s It indicates the time for the voltage to decline from rated motor voltage to 0 V.	0.0s	☆
F3-17	Stop mode selection upon V/F separation	0: Frequency and voltage declining to 0 independently 1: Frequency declining after voltage declines to 0	0	☆

Function Code	Parameter Name	Setting Range	Default	Property
Group F4: Input Terminals				
F4-00	DI1 function selection	0: No function 1: Forward RUN (FWD) 2: Reverse RUN (REV) 3: Three-line control 4: Forward JOG (FJOG) 5: Reverse JOG (RJOG) 6: Terminal UP	1	★
F4-01	DI2 function selection	7: Terminal DOWN 8: Coast to stop 9: Fault reset (RESET) 10: RUN pause 11: Normally open (NO) input of external fault 12: Multi-reference terminal 1 13: Multi-reference terminal 2	4	★
F4-02	DI3 function selection	14: Multi-reference terminal 3 15: Multi-reference terminal 4 16: Terminal 1 for acceleration/ deceleration time selection 17: Terminal 2 for acceleration/ deceleration time selection	9	★
F4-03	DI4 function selection	18: Frequency source switchover 19: UP and DOWN setting clear (terminal, operation panel) 20: Command source switchover terminal 1 21: Acceleration/Deceleration prohibited 22: PID pause 23: PLC status reset 24: Swing pause 25: Counter input 26: Counter reset	12	★
F4-04	DI5 function selection	27: Length count input 28: Length reset 29: Torque control prohibited	13	★

Function Code	Parameter Name	Setting Range	Default	Property
F4-05	DI6 function selection	30: Pulse input (enabled only for DI5) 31: Reserved 32: Immediate DC braking 33: Normally closed (NC) input of external fault 34: Frequency modification forbidden 35: Reverse PID action direction	0	★
F4-06	DI7 function selection	36: External STOP terminal 1 37: Command source switchover terminal 2 38: PID integral pause 39: Switchover between main frequency source X and preset frequency	0	★
F4-07	DI8 function selection	40: Switchover between auxiliary frequency source Y and preset frequency 41: Motor selection terminal 1 42: Motor selection terminal 2 43: PID parameter switchover	0	★
F4-08	DI9 function selection	44: User-defined fault 1 45: User-defined fault 2 46: Speed control/Torque control switchover 47: Emergency stop	0	★
F4-09	DI10 function selection	48: External STOP terminal 2 49: Deceleration DC braking 50: Clear the current running time 51: Switchover between two-line mode and three-line mode 52-59: Reserved	0	★
F4-10	DI filter time	0.000-1.000s	0.010s	☆
F4-11	Terminal command mode	0: Two-line mode 1 1: Two-line mode 2 2: Three-line mode 1 3: Three-line mode 2	0	★
F4-12	Terminal UP/DOWN rate	0.01-65.535 Hz/s	1.00 Hz/s	☆
F4-13	AI curve 1 minimum input	0.00 V to F4-15	0.00 V	☆

Function Code	Parameter Name	Setting Range	Default	Property
F4-14	Corresponding setting of AI curve 1 minimum input	-100.00%~100.0%	0.0%	☆
F4-15	AI curve 1 maximum input	F4-13 to 10.00 V	10.00 V	☆
F4-16	Corresponding setting of AI curve 1 maximum input	-100.00%~100.0%	100.0%	☆
F4-17	AI1 filter time	0.00~10.00s	0.10s	☆
F4-18	AI curve 2 minimum input	0.00 V to F4-20	0.00 V	☆
F4-19	Corresponding setting of AI curve 2 minimum input	-100.00%~100.0%	0.0%	☆
F4-20	AI curve 2 maximum input	F4-18 to 10.00 V	10.00 V	☆
F4-21	Corresponding setting of AI curve 2 maximum input	-100.00%~100.0%	100.0%	☆
F4-22	AI2 filter time	0.00~10.00s	0.10s	☆
F4-23	AI curve 3 minimum input	0.00 V to F4-25	0.00 V	☆
F4-24	Corresponding setting of AI curve 3 minimum input	-100.00%~100.0%	0.0%	☆
F4-25	AI curve 3 maximum input	F4-23 to 10.00 V	10.00 V	☆
F4-26	Corresponding setting of AI curve 3 maximum input	-100.00%~100.0%	100.0%	☆
F4-27	AI3 filter time	0.00~10.00s	0.10s	☆
F4-28	Pulse minimum input	0.00 kHz to F4-30	0.00 kHz	☆
F4-29	Corresponding setting of pulse minimum input	-100.00%~100.0%	0.0%	☆
F4-30	Pulse maximum input	F4-28 to 50.00 kHz	50.00 kHz	☆
F4-31	Corresponding setting of pulse maximum input	-100.00%~100.0%	100.0%	☆
F4-32	Pulse filter time	0.00~10.00s	0.10s	☆

Function Code	Parameter Name	Setting Range	Default	Property
F4-33	AI curve selection	Unit's digit (AI1 curve selection)	321	☆
		Curve 1 (2 points, see F4-13 to F4-16)		
		Curve 2 (2 points, see F4-18 to F4-21)		
		Curve 3 (2 points, see F4-23 to F4-26)		
		Curve 4 (4 points, see A6-00 to A6-07)		
		Curve 5 (4 points, see A6-08 to A6-15)		
		Ten's digit (AI2 curve selection)		
		Curve 1 to curve 5 (same as AI1)		
		Hundred's digit (AI3 curve selection)		
	Curve 1 to curve 5 (same as AI1)			
F4-34	Setting for AI less than minimum input	Unit's digit (Setting for AI1 less than minimum input)	000	☆
		0: Minimum value 1: 0.0%		
		Ten's digit (Setting for AI2 less than minimum input)		
		0, 1 (same as AI1)		
		Hundred's digit (Setting for AI3 less than minimum input)		
	0, 1 (same as AI1)			
F4-35	DI1 delay time	0.0–3600.0s	0.0s	★
F4-36	DI2 delay time	0.0–3600.0s	0.0s	★
F4-37	DI3 delay time	0.0–3600.0s	0.0s	★
F4-38	DI valid mode selection 1	Unit's digit (DI1 valid mode)	00000	★
		0: High level valid 1: Low level valid		
		Ten's digit (DI2 valid mode)		
		0, 1 (same as DI1)		
		Hundred's digit (DI3 valid mode)		
		0, 1 (same as DI1)		

Function Code	Parameter Name	Setting Range	Default	Property
F4-38	DI valid mode selection 1	Thousand's digit (DI4 valid mode)	00000	★
		0, 1 (same as DI1)		
		Ten thousand's digit (DI5 valid mode)		
		0, 1 (same as DI1)		
F4-39	DI valid mode selection 2	Unit's digit (DI6 valid mode)	00000	★
		0, 1 (same as DI1)		
		Ten's digit (DI7 valid mode)		
		0, 1 (same as DI1)		
		Hundred's digit (DI8 state)		
		0, 1 (same as DI1)		
		Thousand's digit (DI9 valid mode)		
		0, 1 (same as DI1)		
		Ten thousand's digit (DI10 valid mode)		
0, 1 (same as DI1)				
F4-40	AI2 input signal selection	0: Voltage signal 1: Current signal	0	★
Group F5: Output Terminals				
F5-00	FM terminal output mode	0: Pulse output (FMP) 1: Switch signal output (FMR)	0	☆
F5-01	FMR function (open-collector output terminal)	0: No output	2	☆
F5-02	Relay function (T/A-T/B-T/C)	1: AC drive running 2: Fault output (stop) 3: Frequency-level detection FDT1 output 4: Frequency reached 5: Zero-speed running (no output at stop) 6: Motor overload pre-warning 7: AC drive overload pre-warning 8: Set count value reached 9: Designated count value reached 10: Length reached 11: PLC cycle complete 12: Accumulative running time reached 13: Frequency limited	2	☆

Function Code	Parameter Name	Setting Range	Default	Property
F5-03	Extension card relay function (P/A-P/B-P/C)	14: Torque limited 15: Ready for RUN	0	☆
F5-04	O1 function selection (open-collector output terminal)	16: AI1 larger than AI2 17: Frequency upper limit reached		
F5-04	DO1 function selection (open-collector output terminal)	18: Frequency lower limit reached (no output at stop) 19: Undervoltage state output 20: Communication setting 21: Reserved 22: Reserved	1	☆
F5-05	Extension card DO2 function	23: Zero-speed running 2 (having output at stop) 24: Accumulative power-on time reached 25: Frequency level detection FDT2 output 26: Frequency 1 reached 27: Frequency 2 reached 28: Current 1 reached 29: Current 2 reached 30: Timing reached 31: AI1 input limit exceeded 32: Load becoming 0 33: Reverse running 34: Zero current state 35: Module temperature reached 36: Software current limit exceeded 37: Frequency lower limit reached (having output at stop) 38: Alarm output 39: Motor overheat warning 40: Current running time reached 41: Fault output (There is no output if it is the coast to stop fault and undervoltage occurs.)	4	☆

Function Code	Parameter Name	Setting Range	Default	Property
F5-06	FMP function selection	0: Running frequency	0	☆
F5-07	AO1 function selection	1: Set frequency	0	☆
F5-08	AO2 function selection	2: Output current 3: Output torque (absolute value) 4: Output power 5: Output voltage 6: Pulse input 7: AI1 8: AI2 9: AI3 10: Length 11: Count value 12: Communication setting 13: Motor rotational speed 14: Output current 15: Output voltage 16: Output torque (actual value)	1	☆
F5-09	Maximum FMP output frequency	0.01–100.00 kHz	50.00 kHz	☆
F5-10	AO1 offset coefficient	-100.0%–100.0%	0.0%	☆
F5-11	AO1 gain	-10.00–10.00	1.00	☆
F5-12	AO2 offset coefficient	-100.0%–100.0%	0.00%	☆
F5-13	AO2 gain	-10.00–10.00	1.00	☆
F5-17	FMR output delay time	0.0–3600.0s	0.0s	☆
F5-18	Relay 1 output delay time	0.0–3600.0s	0.0s	☆
F5-19	Relay 2 output delay time	0.0–3600.0s	0.0s	☆
F5-20	DO1 output delay time	0.0–3600.0s	0.0s	☆
F5-21	DO2 output delay time	0.0–3600.0s	0.0s	☆

Function Code	Parameter Name	Setting Range	Default	Property
F5-22	DO valid mode selection	Unit's digit (FMR valid mode)	00000	☆
		0: Positive logic 1: Negative logic		
		Ten's digit (Relay 1 valid mode)		
		0, 1 (same as FMR)		
		Hundred's digit (Relay 2 valid mode)		
		0, 1 (same as FMR)		
		Thousand's digit (DO1 valid mode)		
		0, 1 (same as FMR)		
		Ten thousand's digit (DO2 valid mode)		
0, 1 (same as FMR)				
F5-23	AO1 output signal selection	0: Voltage signal 1: Current signal	0	★
Group F6: Start/Stop Control				
F6-00	Start mode	0: Direct start 1: Rotational speed tracking restart 2: Pre-excited start (asynchronous motor)	0	☆
F6-01	Rotational speed tracking mode	0: From frequency at stop 1: From zero speed 2: From maximum frequency	0	★
F6-02	Rotational speed tracking speed	1–100	20	☆
F6-03	Startup frequency	0.00–10.00 Hz	0.00 Hz	☆
F6-04	Startup frequency holding time	0.0–100.0s	0.0s	★
F6-05	Startup DC braking current/ Pre-excited current	0%–100%	0%	★
F6-06	Startup DC braking time/ Pre-excited time	0.0–100.0s	0.0s	★
F6-07	Acceleration/Deceleration mode	0: Linear acceleration/ deceleration 1: S-curve acceleration/ deceleration A 2: S-curve acceleration/ deceleration B	0	★

Function Code	Parameter Name	Setting Range	Default	Property
F6-08	Time proportion of S-curve start segment	0.0% to (100.0% – F6-09)	30.0%	★
F6-09	Time proportion of S-curve end segment	0.0% to (100.0% – F6-08)	30.0%	★
F6-10	Stop mode	0: Decelerate to stop 1: Coast to stop	0	☆
F6-11	Initial frequency of stop DC braking	0.00 Hz to maximum frequency	0.00 Hz	☆
F6-12	Waiting time of stop DC braking	0.0–36.0s	0.0s	☆
F6-13	Stop DC braking current	0%–100%	0%	☆
F6-14	Stop DC braking time	0.0–36.0s	0.0s	☆
F6-15	Brake use ratio	0%–100%	100%	☆
Group F7: Operation Panel and Display				
F7-01	MF.K Key function selection	0: MF.K key disabled 1: Switchover between operation panel control and remote command control (terminal or communication) 2: Switchover between forward rotation and reverse rotation 3: Forward JOG 4: Reverse JOG	0	★
F7-02	STOP/RESET key function	0: STOP/RESET key enabled only in operation panel control 1: STOP/RESET key enabled in any operation mode	1	☆
F7-03	LED display running parameters 1	0000–FFFF Bit00: Running frequency 1 (Hz) Bit01: Set frequency (Hz) Bit02: Bus voltage (V) Bit03: Output voltage (V) Bit04: Output current (A) Bit05: Output power (kW) Bit06: Output torque (%) Bit07: DI input status	1F	☆

Function Code	Parameter Name	Setting Range	Default	Property
F7-03	LED display running parameters 1	Bit08: DO output status Bit09: AI1 voltage (V) Bit10: AI2 voltage (V) Bit11: AI3 voltage (V) Bit12: Count value Bit13: Length value Bit14: Load speed display Bit15: PID setting	1F	☆
F7-04	LED display running parameters 2	0000–FFFF Bit00: PID feedback Bit01: PLC stage Bit02: Pulse setting frequency (kHz) Bit03: Running frequency 2 (Hz) Bit04: Remaining running time Bit05: AI1 voltage before correction (V) Bit06: AI2 voltage before correction (V) Bit07: AI3 voltage before correction (V) Bit08: Linear speed Bit09: Current power-on time (Hour) Bit10: Current running time (Min) Bit11: Pulse setting frequency (Hz) Bit12: Communication setting value Bit13: Encoder feedback speed (Hz) Bit14: Main frequency X display (Hz) Bit15: Auxiliary frequency Y display (Hz)	0	☆

Function Code	Parameter Name	Setting Range	Default	Property
F7-05	LED display stop parameters	0000–FFFF Bit00: Set frequency (Hz) Bit01: Bus voltage (V) Bit02: DI input status Bit03: DO output status Bit04: AI1 voltage (V) Bit05: AI2 voltage (V) Bit06: AI3 voltage (V) Bit07: Count value Bit08: Length value Bit09: PLC stage Bit10: Load speed Bit11: PID setting Bit12: Pulse setting frequency (kHz)	33	☆
F7-06	Load speed display coefficient	0.0001–6.5000	1.0000	☆
F7-07	Heatsink temperature of inverter module	0.0–100.0°C	-	●
F7-08	Temporary software version	-	-	●
F7-09	Accumulative running time	0–65535 h	-	●
F7-10	Product number	-	-	●
F7-11	Software version	-	-	●
F7-12	Number of decimal places for load speed display	0: 0 decimal place 1: 1 decimal place 2: 2 decimal places 3: 3 decimal places	1	☆
F7-13	Accumulative power-on time	0–65535 h	0 h	●
F7-14	Accumulative power consumption	0–65535 kWh	-	●
Group F8: Auxiliary Functions				
F8-00	JOG running frequency	0.00 Hz to maximum frequency	2.00 Hz	☆
F8-01	JOG acceleration time	0.0–6500.0s	20.0s	☆
F8-02	JOG deceleration time	0.0–6500.0s	20.0s	☆
F8-03	Acceleration time 2	0.0–6500.0s	Model dependent	☆
F8-04	Deceleration time 2	0.0–6500.0s	Model dependent	☆

Function Code	Parameter Name	Setting Range	Default	Property
F8-05	Acceleration time 3	0.0–6500.0s	Model dependent	☆
F8-06	Deceleration time 3	0.0–6500.0s	Model dependent	☆
F8-07	Acceleration time 4	0.0–500.0s	Model dependent	☆
F8-08	Deceleration time 4	0.0–6500.0s	Model dependent	☆
F8-09	Jump frequency 1	0.00 Hz to maximum frequency	0.00 Hz	☆
F8-10	Jump frequency 2	0.00 Hz to maximum frequency	0.00 Hz	☆
F8-11	Frequency jump amplitude	0.00 Hz to maximum frequency	0.00 Hz	☆
F8-12	Forward/Reverse rotation dead-zone time	0.0–3000.0s	0.0s	☆
F8-13	Reverse control	0: Enabled 1: Disabled	0	☆
F8-14	Running mode when set frequency lower than frequency lower limit	0: Run at frequency lower limit 1: Stop 2: Run at zero speed	0	☆
F8-15	Droop control	0.00–10.00 Hz	0.00 Hz	☆
F8-16	Accumulative power-on time threshold	0–65000 h	0 h	☆
F8-17	Accumulative running time threshold	0–65000 h	0 h	☆
F8-18	Startup protection	0: No 1: Yes	0	☆
F8-19	Frequency detection value (FDT1)	0.00 Hz to maximum frequency	50.00 Hz	☆
F8-20	Frequency detection hysteresis (FDT hysteresis 1)	0.0%–100.0% (FDT1 level)	5.0%	☆
F8-21	Detection range of frequency reached	0.00–100% (maximum frequency)	0.0%	☆
F8-22	Jump frequency during acceleration/deceleration	0: Disabled 1: Enabled	0	☆
F8-25	Frequency switchover point between acceleration time 1 and acceleration time 2	0.00 Hz to maximum frequency	0.00 Hz	☆
F8-26	Frequency switchover point between deceleration time 1 and deceleration time 2	0.00 to maximum frequency	0.00 Hz	☆
F8-27	Terminal JOG preferred	0: Disabled 1: Enabled	0	☆

Function Code	Parameter Name	Setting Range	Default	Property
F8-28	Frequency detection value (FDT2)	0.00 to maximum frequency	50.00 Hz	☆
F8-29	Frequency detection hysteresis (FDT hysteresis 2)	0.0%–100.0% (FDT2 level)	5.0%	☆
F8-30	Any frequency reaching detection value 1	0.00 Hz to maximum frequency	50.00 Hz	☆
F8-31	Any frequency reaching detection amplitude 1	0.0%–100.0% (maximum frequency)	0.0%	☆
F8-32	Any frequency reaching detection value 2	0.00 Hz to maximum frequency	50.00 Hz	☆
F8-33	Any frequency reaching detection amplitude 2	0.0%–100.0% (maximum frequency)	0.0%	☆
F8-34	Zero current detection level	0.0%–300.0% (rated motor current)	5.0%	☆
F8-35	Zero current detection delay time	0.00–600.00s	0.10s	☆
F8-36	Output overcurrent threshold	0.0% (no detection) 0.1%–300.0% (rated motor current)	200.0%	☆
F8-37	Output overcurrent detection delay time	0.00–600.00s	0.00s	☆
F8-38	Any current reaching 1	0.0%–300.0% (rated motor current)	100.0%	☆
F8-39	Any current reaching 1 amplitude	0.0%–300.0% (rated motor current)	0.0%	☆
F8-40	Any current reaching 2	0.0%–300.0% (rated motor current)	100.0%	☆
F8-41	Any current reaching 2 amplitude	0.0%–300.0% (rated motor current)	0.0%	☆
F8-42	Timing function	0: Disabled 1: Enabled	0	☆
F8-43	Timing duration source	0: F8-44 1: AI1 2: AI2 3: AI3 (100% of analog input corresponds to the value of F8-44)	0	☆
F8-44	Timing duration	0.0–6500.0 min	0.0 min	☆
F8-45	AI1 input voltage lower limit	0.00 V to F8-46	3.10 V	☆
F8-46	AI1 input voltage upper limit	F8-45 to 10.00 V	6.80 V	☆

Function Code	Parameter Name	Setting Range	Default	Property
F8-47	Module temperature threshold	0–100°C	75°C	☆
F8-48	Cooling fan control	0: Fan working during running 1: Fan working continuously	0	☆
F8-49	Wakeup frequency	Dormant frequency (F8-51) to maximum frequency (F0-10)	0.00 Hz	☆
F8-50	Wakeup delay time	0.0–6500.0s	0.0s	☆
F8-51	Dormant frequency	0.00 Hz to wakeup frequency (F8-49)	0.00 Hz	☆
F8-52	Dormant delay time	0.0–6500.0s	0.0s	☆
F8-53	Current running time reached	0.0–6500.0 min	0.0 min	☆
F8-54	Output power correction coefficient	0.00%–200.0%	100.0%	☆
Group F9: Fault and Protection				
F9-00	Motor overload protection selection	0: Disabled 1: Enabled	1	☆
F9-01	Motor overload protection gain	0.20–10.00	1.00	☆
F9-02	Motor overload warning coefficient	50%–100%	80%	☆
F9-03	Overvoltage stall gain	0 (no stall overvoltage)–100	0	☆
F9-04	Overvoltage stall protective voltage	120%–150%	130%	☆
F9-05	Overcurrent stall gain	0–100	20	☆
F9-06	Overcurrent stall protective current	100%–200%	150%	☆
F9-07	Short-circuit to ground upon power-on	0: Disabled 1: Enabled	1	☆
F9-09	Fault auto reset times	0–20	0	☆
F9-10	DO action during fault auto reset	0: Not act 1: Act	0	☆
F9-11	Time interval of fault auto reset	0.1s–100.0s	1.0s	☆
F9-12	Input phase loss protection/ contactor energizing protection selection	Unit's digit: Input phase loss protection Ten's digit: Contactor energizing protection 0: Disabled 1: Enabled	11	☆

Function Code	Parameter Name	Setting Range	Default	Property
F9-13	Output phase loss protection selection	0: Disabled 1: Enabled	1	☆
F9-14	1st fault type	0: No fault	-	●
F9-15	2nd fault type	1: Reserved 2: Overcurrent during acceleration 3: Overcurrent during deceleration 4: Overcurrent at constant speed 5: Overvoltage during acceleration 6: Overvoltage during deceleration 7: Overvoltage at constant speed 8: Buffer resistance overload 9: Undervoltage 10: AC drive overload 11: Motor overload 12: Power input phase loss 13: Power output phase loss 14: Module overheat 15: External equipment fault 16: Communication fault 17: Contactor fault 18: Current detection fault 19: Motor auto-tuning fault 20: Encoder/PG card fault 21: EEPROM read-write fault 22: AC drive hardware fault 23: Short circuit to ground 24: Reserved 25: Reserved 26: Accumulative running time reached 27: User-defined fault 1 28: User-defined fault 2 29: Accumulative power-on time reached 30: Load becoming 0 31: PID feedback lost during running	-	●

Function Code	Parameter Name	Setting Range	Default	Property
F9-16	3rd (latest) fault type	40: With-wave current limit fault 41: Motor switchover fault during running 42: Too large speed deviation 43: Motor over-speed 45: Motor overheat 51: Initial position fault	-	●
F9-17	Frequency upon 3rd fault	-	-	●
F9-18	Current upon 3rd fault	-	-	●
F9-19	Bus voltage upon 3rd fault	-	-	●
F9-20	DI status upon 3rd fault	-	-	●
F9-21	Output terminal status upon 3rd fault	-	-	●
F9-22	AC drive status upon 3rd fault	-	-	●
F9-23	Power-on time upon 3rd fault	-	-	●
F9-24	Running time upon 3rd fault	-	-	●
F9-27	Frequency upon 2nd fault	-	-	●
F9-28	Current upon 2nd fault	-	-	●
F9-29	Bus voltage upon 2nd fault	-	-	●
F9-30	DI status upon 2nd fault	-	-	●
F9-31	Output terminal status upon 2nd fault	-	-	●
F9-32	Frequency upon 2nd fault	-	-	●
F9-33	Current upon 2nd fault	-	-	●
F9-34	Bus voltage upon 2nd fault	-	-	●
F9-37	DI status upon 1st fault	-	-	●
F9-38	Output terminal status upon 1st fault	-	-	●
F9-39	Frequency upon 1st fault	-	-	●
F9-40	Current upon 1st fault	-	-	●
F9-41	Bus voltage upon 3rd fault	-	-	●
F9-42	DI status upon 1st fault	-	-	●
F9-43	Output terminal status upon 1st fault	-	-	●
F9-44	Frequency upon 1st fault	-	-	●

Function Code	Parameter Name	Setting Range	Default	Property
F9-47	Fault protection action selection 1	Unit's digit (Motor overload, Err11)	00000	☆
		0: Coast to stop 1: Stop according to the stop mode 2: Continue to run		
		Ten's digit (Power input phase loss, Err12)		
		Same as unit's digit		
		Hundred's digit (Power output phase loss, Err13)		
		Same as unit's digit		
		Thousand's digit (External equipment fault, Err15)		
		Same as unit's digit		
		Ten thousand's digit (Communication fault, Err16)		
		Same as unit's digit		
F9-48	Fault protection action selection 2	Unit's digit (Encoder fault, Err20)	00000	☆
		0: Coast to stop 1: Switch over to V/F control, stop according to the stop mode 2: Switch over to V/F control, continue to run		
		Ten's digit (EEPROM read-write fault, Err21)		
		0: Coast to stop 1: Stop according to the stop mode		
F9-48	Fault protection action selection 2	Hundred's digit: reserved	00000	☆
		Thousand's digit (Motor overheat, Err25)		
		Same as unit's digit in F9-47		
		Ten thousand's digit (Accumulative running time reached)		
		Same as unit's digit in F9-47		

Function Code	Parameter Name	Setting Range	Default	Property
F9-49	Fault protection action selection 3	Unit's digit (User-defined fault 1, Err27)	00000	☆
		Same as unit's digit in F9-47		
		Ten's digit (User-defined fault 2, Err28)		
		Same as unit's digit in F9-47		
		Hundred's digit (Accumulative power-on time reached, Err29)		
		Same as unit's digit in F9-47		
		Thousand's digit (Load becoming 0, Err30)		
		0: Coast to stop 1: Stop according to the stop mode 2: Continue to run at 7% of rated motor frequency and resume to the set frequency if the load recovers		
		Ten thousand's digit (PID feedback lost during running, Err31)		
F9-50	Fault protection action selection 4	Unit's digit (Too large speed deviation, Err42)	00000	☆
		Same as unit's digit in F9-47		
		Ten's digit (Motor over-speed, Err43)		
		Same as unit's digit in F9-47		
		Hundred's digit (Initial position fault, Err51)		
		Same as unit's digit in F9-47		
		Thousand's digit (Speed feedback fault, Err52)		
		Same as unit's digit in F9-47		
		Ten thousand's digit: Reserved		
F9-54	Frequency selection for continuing to run upon fault	0: Current running frequency 1: Set frequency 2: Frequency upper limit 3: Frequency lower limit 4: Backup frequency upon abnormality	0	☆

Function Code	Parameter Name	Setting Range	Default	Property
F9-55	Backup frequency upon abnormality	0.0%–100.0% (maximum frequency)	100.0%	☆
F9-56	Type of motor temperature sensor	0: No temperature sensor 1: PT100 2: PT1000	1	☆
F9-57	Motor overheat protection threshold	0–200°C	110°C	☆
F9-58	Motor overheat warning threshold	0–200°C	90°C	☆
F9-59	Action selection at instantaneous power failure	0: Invalid 1: Decelerate 2: Decelerate to stop	0	☆
F9-60	Action pause judging voltage at instantaneous power failure	80.0%–100.0%	90.0%	☆
F9-61	Voltage rally judging time at instantaneous power failure	0.00–100.00s	0.50s	☆
F9-62	Action judging voltage at instantaneous power failure	60.0%–100.0% (standard bus voltage)	80.0%	☆
F9-63	Protection upon load becoming 0	0: Disabled 1: Enabled	0	☆
F9-64	Detection level of load becoming 0	0.0%–100.0% (rated motor current)	10.0%	☆
F9-65	Detection time of load becoming 0	0.0–60.0s	1.0s	☆
F9-67	Over-speed detection value	0.0%–50.0% (maximum frequency)	20.0%	☆
F9-68	Over-speed detection time	0.0–60.0s	1.0s	☆
F9-69	Detection value of too large speed deviation	0.0%–50.0% (maximum frequency)	20.0%	☆
F9-70	Detection time of too large speed deviation	0.0–60.0s	5.0s	☆
Group FA: Process Control PID Function				
FA-00	PID setting source	0: FA-01 1: AI1 2: AI2 3: AI3 4: Pulse setting (DI5) 5: Communication setting 6: Multi-reference	0	☆
FA-01	PID digital setting	0.0%–100.0%	50.0%	☆

Function Code	Parameter Name	Setting Range	Default	Property
FA-02	PID feedback source	0: AI1 1: AI2 2: AI3 3: AI1 – AI2 4: Pulse setting (DI5) 5: Communication setting 6: AI1 + AI2 7: MAX (AI1 , AI2) 8: MIN (AI1 , AI2)	0	☆
FA-03	PID action direction	0: Forward action 1: Reverse action	0	☆
FA-04	PID setting feedback range	0–65535	1000	☆
FA-05	Proportional gain Kp1	0.0–100.0	20.0	☆
FA-06	Integral time Ti1	0.01–10.00s	2.00s	☆
FA-07	Differential time Td1	0.00–10.000	0.000s	☆
FA-08	Cut-off frequency of PID reverse rotation	0.00 to maximum frequency	2.00 Hz	☆
FA-09	PID deviation limit	0.0%–100.0%	0.0%	☆
FA-10	PID differential limit	0.00%–100.00%	0.10%	☆
FA-11	PID setting change time	0.00–650.00s	0.00s	☆
FA-12	PID feedback filter time	0.00–60.00s	0.00s	☆
FA-13	PID output filter time	0.00–60.00s	0.00s	☆
FA-14	Reserved	-	-	☆
FA-15	Proportional gain Kp2	0.0–100.0	20.0	☆
FA-16	Integral time Ti2	0.01–10.00s	2.00s	☆
FA-17	Differential time Td2	0.000–10.000s	0.000s	☆
FA-18	PID parameter switchover condition	0: No switchover 1: Switchover via DI 2: Automatic switchover based on deviation	0	☆
FA-19	PID parameter switchover deviation 1	0.0% to FA-20	20.0%	☆
FA-20	PID parameter switchover deviation 2	FA-19 to 100.0%	80.0%	☆
FA-21	PID initial value	0.0%–100.0%	0.0%	☆
FA-22	PID initial value holding time	0.00–650.00s	0.00s	☆
FA-23	Maximum deviation between two PID outputs in forward direction	0.00%–100.00%	1.00%	☆

Function Code	Parameter Name	Setting Range	Default	Property
FA-24	Maximum deviation between two PID outputs in reverse direction	0.00%–100.00%	1.00%	☆
FA-25	PID integral property	Unit's digit (Integral separated)	00	☆
		0: Invalid 1: Valid		
		Ten's digit (Whether to stop integral operation when the output reaches the limit)		
		0: Continue integral operation 1: Stop integral operation		
FA-26	Detection value of PID feedback loss	0.0%: Not judging feedback loss 0.1%–100.0%	0.0%	☆
FA-27	Detection time of PID feedback loss	0.0–20.0s	0.0s	☆
FA-28	PID operation at stop	0: No PID operation at stop 1: PID operation at stop	0	☆
Group FB: Swing Frequency, Fixed Length and Count				
FB-00	Swing frequency setting mode	0: Relative to the central frequency 1: Relative to the maximum frequency	0	☆
FB-01	Swing frequency amplitude	0.0%–100.0%	0.0%	☆
FB-02	Jump frequency amplitude	0.0%–50.0%	0.0%	☆
FB-03	Swing frequency cycle	0.0–3000.0s	10.0s	☆
FB-04	Triangular wave rising time coefficient	0.0%–100.0%	50.0%	☆
FB-05	Set length	0–65535 m	1000 m	☆
FB-06	Actual length	0–65535 m	0 m	☆
FB-07	Number of pulses per meter	0.1–6553.5	100.0	☆
FB-08	Set count value	1–65535	1000	☆
FB-09	Designated count value	1–65535	1000	☆
Group FC: Multi-Reference and Simple PLC Function				
FC-00	Reference 0	-100.0%–100.0%	0.0%	☆
FC-01	Reference 1	-100.0%–100.0%	0.0%	☆
FC-02	Reference 2	-100.0%–100.0%	0.0%	☆
FC-03	Reference 3	-100.0%–100.0%	0.0%	☆
FC-04	Reference 4	-100.0%–100.0%	0.0%	☆

Function Code	Parameter Name	Setting Range	Default	Property
FC-05	Reference 5	-100.0%~100.0%	0.0%	☆
FC-06	Reference 6	-100.0%~100.0%	0.0%	☆
FC-07	Reference 7	-100.0%~100.0%	0.0%	☆
FC-08	Reference 8	-100.0%~100.0%	0.0%	☆
FC-09	Reference 9	-100.0%~100.0%	0.0%	☆
FC-10	Reference 10	-100.0%~100.0%	0.0%	☆
FC-11	Reference 11	-100.0%~100.0%	0.0%	☆
FC-12	Reference 12	-100.0%~100.0%	0.0%	☆
FC-13	Reference 13	-100.0%~100.0%	0.0%	☆
FC-14	Reference 14	-100.0%~100.0%	0.0%	☆
FC-15	Reference 15	-100.0%~100.0%	0.0%	☆
FC-16	Simple PLC running mode	0: Stop after the AC drive runs one cycle 1: Keep final values after the AC drive runs one cycle 2: Repeat after the AC drive runs one cycle	0	☆
FC-17	Simple PLC retentive selection	Unit's digit (Retentive upon power failure)	00	☆
		0: No 1: Yes		
		Ten's digit (Retentive upon stop)		
		0: No 1: Yes		
FC-18	Running time of simple PLC reference 0	0.0~6553.5s (h)	0.0s (h)	☆
FC-19	Acceleration/deceleration time of simple PLC reference 0	0~3	0	☆
FC-20	Running time of simple PLC reference 1	0.0~6553.5s (h)	0.0s (h)	☆
FC-21	Acceleration/deceleration time of simple PLC reference 1	0~3	0	☆
FC-22	Running time of simple PLC reference 2	0.0~6553.5s (h)	0.0s (h)	☆
FC-23	Acceleration/deceleration time of simple PLC reference 2	0~3	0	☆
FC-24	Running time of simple PLC reference 3	0.0~6553.5s (h)	0.0s (h)	☆
FC-25	Acceleration/deceleration time of simple PLC reference 3	0~3	0	☆

Function Code	Parameter Name	Setting Range	Default	Property
FC-26	Running time of simple PLC reference 4	0.0–6553.5s (h)	0.0s (h)	☆
FC-27	Acceleration/deceleration time of simple PLC reference 4	0–3	0	☆
FC-28	Running time of simple PLC reference 5	0.0–6553.5s (h)	0.0s (h)	☆
FC-29	Acceleration/deceleration time of simple PLC reference 5	0–3	0	☆
FC-30	Running time of simple PLC reference 6	0.0–6553.5s (h)	0.0s (h)	☆
FC-31	Acceleration/deceleration time of simple PLC reference 6	0–3	0	☆
FC-32	Running time of simple PLC reference 7	0.0–6553.5s (h)	0.0s (h)	☆
FC-33	Acceleration/deceleration time of simple PLC reference 7	0–3	0	☆
FC-34	Running time of simple PLC reference 8	0.0–6553.5s (h)	0.0s (h)	☆
FC-35	Acceleration/deceleration time of simple PLC reference 8	0–3	0	☆
FC-36	Running time of simple PLC reference 9	0.0–6553.5s (h)	0.0s (h)	☆
FC-37	Acceleration/deceleration time of simple PLC reference 9	0–3	0	☆
FC-38	Running time of simple PLC reference 10	0.0–6553.5s (h)	0.0s (h)	☆
FC-39	Acceleration/deceleration time of simple PLC reference 10	0–3	0	☆
FC-40	Running time of simple PLC reference 11	0.0–6553.5s (h)	0.0s (h)	☆
FC-41	Acceleration/deceleration time of simple PLC reference 11	0–3	0	☆
FC-42	Running time of simple PLC reference 12	0.0–6553.5s (h)	0.0s (h)	☆
FC-43	Acceleration/deceleration time of simple PLC reference 12	0–3	0	☆
FC-44	Running time of simple PLC reference 13	0.0–6553.5s (h)	0.0s (h)	☆
FC-45	Acceleration/deceleration time of simple PLC reference 13	0–3	0	☆
FC-46	Running time of simple PLC reference 14	0.0–6553.5s (h)	0.0s (h)	☆

Function Code	Parameter Name	Setting Range	Default	Property
FC-47	Acceleration/deceleration time of simple PLC reference 14	0-3	0	☆
FC-48	Running time of simple PLC reference 15	0.0-6553.5s (h)	0.0s (h)	☆
FC-49	Acceleration/deceleration time of simple PLC reference 15	0-3	0	☆
FC-50	Time unit of simple PLC running	0: s (second)1:h (hour)	0	☆
FC-51	Reference 0 source	0: Set by FC-00 1: AI1 2: AI2 3: AI3 4: Pulse setting 5: PID 6: Set by preset frequency (F0-08), modified via terminal UP/DOWN	0	☆

Function Code	Parameter Name	Setting Range	Default	Property
Group FD: Communication Parameters				
FD-00	Baud rate	Unit's digit (Modbus baud rate)	6005	☆
		0: 300 BPs 1: 600 BPs 2: 1200 BPs 3: 2400 BPs 4: 4800 BPs 5: 9600 BPs 6: 19200 BPs 7: 38400 BPs 8: 57600 BPs 9: 115200 BPs		
		Ten's digit (PROFIBUS-DP baud rate)		
		0: 115200 BPs 1: 208300 BPs 2: 256000 BPs 3: 512000 Bps		
		Hundred's digit (reserved)		
Thousand's digit (CANlink baud rate)	0: 20 1: 50 2: 100 3: 125 4: 250 5: 500 6: 1 M			
FD-01	Data format	0: No check, data format <8,N,2> 1: Even parity check, data format <8,E,1> 2: Odd Parity check, data format <8,O,1> 3: No check, data format <8,N,1> Valid for Modbus	0	☆
FD-02	Local address	0: Broadcast address 1-247 Valid for Modbus, PROFIBUS-DP and CANlink	1	☆

Function Code	Parameter Name	Setting Range	Default	Property
FD-03	Response delay	0–20 ms Valid for Modbus	2 ms	☆
FD-04	Communication timeout	0.0s (invalid) 0.1–60.0s Valid for Modbus, PROFIBUS-DP and CANopen	0.0s	☆
FD-05	Modbus protocol selection and PROFIBUS-DP data format	Unit's digit: Modbus protocol	30	☆
		0: Non-standard Modbus protocol 1: Standard Modbus protocol		
		Ten's digit: PROFIBUS-DP data format		
		0: PPO1 format 1: PPO2 format 2: PPO3 format 3: PPO5 format		
FD-06	Communication reading current resolution	0: 0.01A 1: 0.1A	0	☆
FD-08	CANlink communication timeout time	0.0s: Invalid 0.1–60.0s	0	☆
Group FE: User-defined Parameters				
FE-00	User-defined function code 0	F0-00 to FP-xx A0-00 to Ax-xx U0-xx to U0-xx	F0-10	☆
FE-01	User-defined function code 1		F0-02	☆
FE-02	User-defined function code 2		F0-03	☆
FE-03	User-defined function code 3		F0-07	☆
FE-04	User-defined function code 4		F0-08	☆
FE-05	User-defined function code 5		F0-17	☆
FE-06	User-defined function code 6		F0-18	☆
FE-07	User-defined function code 7		F3-00	☆
FE-08	User-defined function code 8		F3-01	☆
FE-09	User-defined function code 9		F4-00	☆
FE-10	User-defined function code 10		F4-01	☆
FE-11	User-defined function code 11		F4-02	☆
FE-12	User-defined function code 12		F5-04	☆
FE-13	User-defined function code 13		F5-07	☆
FE-14	User-defined function code 14	F6-00	☆	

Function Code	Parameter Name	Setting Range	Default	Property
FE-15	User-defined function code 15	F0-00 to FP-xx A0-00 to Ax-xx U0-xx to U0-xx	F6-10	☆
FE-16	User-defined function code 16		F0-00	☆
FE-17	User-defined function code 17		F0-00	☆
FE-18	User-defined function code 18		F0-00	☆
FE-19	User-defined function code 19		F0-00	☆
FE-20	User-defined function code 20		F0-00	☆
FE-21	User-defined function code 21		F0-00	☆
FE-22	User-defined function code 22		F0-00	☆
FE-23	User-defined function code 23		F0-00	☆
FE-24	User-defined function code 24		F0-00	☆
FE-25	User-defined function code 25		F0-00	☆
FE-26	User-defined function code 26		F0-00	☆
FE-27	User-defined function code 27		F0-00	☆
FE-28	User-defined function code 28		F0-00	☆
FE-29	User-defined function code 29	F0-00	☆	
Group FP: Function Code Management				
FP-00	User password	0-65535	0	☆
FP-01	Restore default settings	0: No operation 01: Restore factory settings except motor parameters 02: Clear records 04: Restore user backup parameters 501: Back up current user parameters	0	★
FP-02	AC drive parameter display property	Unit's digit (Group U display selection) 0: Not display 1: Display Ten's digit (Group A display selection) 0: Not display 1: Display	11	★

Function Code	Parameter Name	Setting Range	Default	Property
FP-03	Individualized parameter display property	Unit's digit (User-defined parameter display selection)	00	☆
		0: Not display 1: Display		
		Ten's digit (User-modified parameter display selection)		
		0: Not display 1: Display		
FP-04	Parameter modification property	0: Modifiable 1: Not modifiable	0	☆
Group A0: Torque Control and Restricting Parameters				
A0-00	Speed/Torque control selection	0: Speed control 1: Torque control	0	★
A0-01	Torque setting source in torque control	0: Digital setting (A0-03) 1: AI1 2: AI2 3: AI3 4: Pulse setting (DI5) 5: Communication setting 6: MIN (AI1, AI2) 7: MAX (AI1, AI2) Full range of values 1–7 corresponds to the digital setting of A0-03.	0	★
A0-03	Torque digital setting in torque control	-200.0%–200.0%	150.0%	☆
A0-05	Forward maximum frequency in torque control	0.00 Hz to maximum frequency (F0-10)	50.00 Hz	☆
A0-06	Reverse maximum frequency in torque control	0.00 Hz to maximum frequency (F0-10)	50.00 Hz	☆
A0-07	Acceleration time in torque control	0.00–65000s	0.00s	☆
A0-08	Deceleration time in torque control	0.00–65000s	0.00s	☆
Group A1: Virtual DI (VDI)/Virtual DO (VDO)				
A1-00	VDI1 function selection	0–59	0	★
A1-01	VDI2 function selection	0–59	0	★
A1-02	VDI3 function selection	0–59	0	★
A1-03	VDI4 function selection	0–59	0	★

Function Code	Parameter Name	Setting Range	Default	Property
A1-04	VDI5 function selection	0-59	0	★
A1-05	VDI state setting mode	Unit's digit (VDI1)	00000	★
		0: Decided by state of VDOx 1: Decided by A1-06		
		Ten's digit (VDI2)		
		0, 1 (same as VDI1)		
		Hundred's digit (VDI3)		
		0, 1 (same as VDI1)		
		Thousand's digit (VDI4)		
		0, 1 (same as VDI1)		
		Ten thousand's digit (VDI5)		
0, 1 (same as VDI1)				
A1-06	VDI state selection	Unit's digit (VDI1)	00000	★
		0: Invalid 1: Valid		
		Ten's digit (VDI2)		
		0, 1 (same as VDI1)		
		Hundred's digit (VDI3)		
		0, 1 (same as VDI1)		
		Thousand's digit (VDI4)		
		0, 1 (same as VDI1)		
		Ten thousand's digit (VDI5)		
0, 1 (same as VDI1)				
A1-07	Function selection for AI1 used as DI	0-59	0	★
A1-08	Function selection for AI2 used as DI	0-59	0	★
A1-09	Function selection for AI3 used as DI	0-59	0	★
A1-10	State selection for AI used as DI	Unit's digit (AI1)	000	★
		0: High level valid 1: Low level valid		
		Ten's digit (AI2)		
		0, 1 (same as unit's digit)		
		Hundred's digit (AI3)		
		0, 1 (same as unit's digit)		

Function Code	Parameter Name	Setting Range	Default	Property
A1-11	VDO1 function selection	0: Short with physical DIx internally 1-40: Refer to function selection of physical DO in group F5.	0	☆
A1-12	VDO2 function selection	0: Short with physical DIx internally 1-40: Refer to function selection of physical DO in group F5.	0	☆
A1-13	VDO3 function selection	0: Short with physical DIx internally 1-40: Refer to function selection of physical DO in group F5.	0	☆
A1-14	VDO4 function selection	0: Short with physical DIx internally 1-40: Refer to function selection of physical DO in group F5.	0	☆
A1-15	VDO5 function selection	0: Short with physical DIx internally 1-40: Refer to function selection of physical DO in group F5.	0	☆
A1-16	VDO1 output delay	0.0-3600.0s	0.0s	☆
A1-17	VDO2 output delay	0.0-3600.0s	0.0s	☆
A1-18	VDO3 output delay	0.0-3600.0s	0.0s	☆
A1-19	VDO4 output delay	0.0-3600.0s	0.0s	☆
A1-20	VDO5 output delay	0.0-3600.0s	0.0s	☆
A1-21	VDO state selection	Unit's digit (VDO1)	00000	☆
		0: Positive logic 1: Reverse logic		
		Ten's digit (VDO2)		
		0, 1 (same as unit's digit)		
		Hundred's digit (VDO3)		
		0, 1 (same as unit's digit)		
		Thousand's digit (VDO4)		
		0, 1 (same as unit's digit)		
		Ten thousand's digit (VDO5)		
0, 1 (same as unit's digit)				

Function Code	Parameter Name	Setting Range	Default	Property
Group A2: Motor 2 Parameters				
A2-00	Motor type selection	0: Common asynchronous motor 1: Variable frequency asynchronous motor 2: Permanent magnetic synchronous motor	0	★
A2-01	Rated motor power	0.1–1000.0 kW	Model dependent	★
A2-02	Rated motor voltage	1–2000 V	Model dependent	★
A2-03	Rated motor current	0.01–655.35 A (AC drive power ≤ 55 kW) 0.1–6553.5 A (AC drive power > 55 kW)	Model dependent	★
A2-04	Rated motor frequency	0.01 Hz to maximum frequency	Model dependent	★
A2-05	Rated motor rotational speed	1–65535 RPM	Model dependent	★
A2-06	Stator resistance (asynchronous motor)	0.001–65.535 Ω (AC drive power ≤ 55 kW) 0.0001–6.5535 Ω (AC drive power > 55 kW)	Model dependent	★
A2-07	Rotor resistance (asynchronous motor)	0.001–65.535 Ω (AC drive power ≤ 55 kW) 0.0001–6.5535 Ω (AC drive power > 55 kW)	Model dependent	★
A2-08	Leakage inductive reactance (asynchronous motor)	0.01–655.35 mH (AC drive power ≤ 55 kW) 0.001–65.535 mH (AC drive power > 55 kW)	Model dependent	★
A2-09	Mutual inductive reactance (asynchronous motor)	0.1–6553.5 mH (AC drive power ≤ 55 kW) 0.01–655.35 mH (AC drive power > 55 kW)	Model dependent	★
A2-10	No-load current (asynchronous motor)	0.01 A to A2-03 (AC drive power ≤ 55 kW) 0.1 A to A2-03 (AC drive power > 55 kW)	Model dependent	★
A2-16	Stator resistance (synchronous motor)	0.001–65.535 Ω (AC drive power ≤ 55 kW) 0.0001–6.5535 Ω (AC drive power > 55 kW)	Model dependent	★

Function Code	Parameter Name	Setting Range	Default	Property
A2-17	Shaft D inductance (synchronous motor)	0.01–655.35 mH (AC drive power ≤ 55 kW) 0.001–65.535 mH (AC drive power > 55 kW)	Model dependent	★
A2-18	Shaft Q inductance (synchronous motor)	0.01–655.35 mH (AC drive power ≤ 55 kW) 0.001–65.535 mH (AC drive power > 55 kW)	Model dependent	★
A2-20	Back EMF (synchronous motor)	0.1–6553.5 V	Model dependent	★
A2-27	Encoder pulses per revolution	1–65535	1024	★
A2-28	Encoder type	0: ABZ incremental encoder 1: UVW incremental encoder 2: Resolver 3: SIN/COS encoder 4: Wire-saving UVW encoder	0	★
A2-30	A, B phase sequence of ABZ incremental encoder	0: Forward 1: Reserve	0	★
A2-31	Encoder installation angle	0.0°–359.9°	0.0°	★
A2-32	U, V, W phase sequence of UVW encoder	0: Forward 1: Reverse	0	★
A2-33	UVW encoder angle offset	0.0°–359.9°	0.0°	★
A2-34	Number of pole pairs of resolver	1–65535	1	★
A2-36	Encoder wire-break fault detection time	0.0s: No action 0.1–10.0s	0.0s	★
A2-37	Auto-tuning selection	0: No auto-tuning 1: Asynchronous motor static auto-tuning 2: Asynchronous motor complete auto-tuning 11: Synchronous motor with-load auto-tuning 12: Synchronous motor no-load auto-tuning	0	★
A2-38	Speed loop proportional gain 1	0–100	30	☆
A2-39	Speed loop integral time 1	0.01–10.00s	0.50s	☆
A2-40	Switchover frequency 1	0.00 to A2-43	5.00 Hz	☆
A2-41	Speed loop proportional gain 2	0–100	15	☆

Function Code	Parameter Name	Setting Range	Default	Property
A2-42	Speed loop integral time 2	0.01–10.00s	1.00s	☆
A2-43	Switchover frequency 2	A2-40 to maximum output frequency	10.00 Hz	☆
A2-44	Vector control slip gain	50%–200%	100%	☆
A2-45	Time constant of speed loop filter	0.000–0.100s	0.000s	☆
A2-46	Vector control over-excitation gain	0–200	64	☆
A2-47	Torque upper limit source in speed control mode	0: A2-48 1: AI1 2: AI2 3: AI3 4: Pulse setting (DI5) 5: Via communication 6: MIN(AI1,AI2) 7: MIN(AI1,AI2)	0	☆
A2-48	Digital setting of torque upper limit in speed control mode	0.0%–200.0%	150.0%	☆
A2-51	Excitation adjustment proportional gain	0–20000	2000	☆
A2-52	Excitation adjustment integral gain	0–20000	1300	☆
A2-53	Torque adjustment proportional gain	0–20000	2000	☆
A2-54	Torque adjustment integral gain	0–20000	1300	☆
A2-55	Speed loop integral property	Unit's digit: Integral separated 0: Disabled 1: Enabled	0	☆
A2-56	Field weakening mode of synchronous motor	0: No field weakening 1: Direct calculation 2: Adjustment	0	☆
A2-57	Field weakening degree of synchronous motor	50%–500%	100%	☆
A2-58	Maximum field weakening current	1%–300%	50%	☆
A2-59	Field weakening automatic adjustment gain	10%–500%	100%	☆
A2-60	Field weakening integral multiple	2–10	2	☆

Function Code	Parameter Name	Setting Range	Default	Property
A2-61	Motor 2 control mode	0: Sensorless flux vector control (SFVC) 1: Closed-loop vector control (CLVC) 2: Voltage/Frequency (V/F) control	0	☆
A2-62	Motor 2 acceleration/ deceleration time	0: Same as motor 1 1: Acceleration/Deceleration time 1 2: Acceleration/Deceleration time 2 3: Acceleration/Deceleration time 3 4: Acceleration/Deceleration time 4	0	☆
A2-63	Motor 2 torque boost	0.0%: Automatic torque boost 0.1%–30.0%	Model dependent	☆
A2-65	Motor 2 oscillation suppression gain	0–100	Model dependent	☆
Group A3: Motor 3 Parameters				
A3-00	Motor type selection	0: Common asynchronous motor 1: Variable frequency asynchronous motor 2: Permanent magnetic synchronous motor	0	★
A3-01	Rated motor power	0.1–1000.0 kW	Model dependent	★
A3-02	Rated motor voltage	1–2000 V	Model dependent	★
A3-03	Rated motor current	0.01–655.35 A (AC drive power ≤ 55 kW) 0.1–6553.5 A (AC drive power > 55 kW)	Model dependent	★
A3-04	Rated motor frequency	0.01 Hz to maximum frequency	Model dependent	★
A3-05	Rated motor rotational speed	1–65535 RPM	Model dependent	★
A3-06	Stator resistance (asynchronous motor)	0.001–65.535 Ω (AC drive power ≤ 55 kW) 0.0001–6.5535 Ω (AC drive power > 55 kW)	Model dependent	★
A3-07	Rotor resistance (asynchronous motor)	0.001–65.535 Ω (AC drive power ≤ 55 kW) 0.0001–6.5535 Ω (AC drive power > 55 kW)	Model dependent	★

Function Code	Parameter Name	Setting Range	Default	Property
A3-08	Leakage inductive reactance (asynchronous motor)	0.01–655.35 mH (AC drive power ≤ 55 kW) 0.001–65.535 mH (AC drive power > 55 kW)	Model dependent	★
A3-09	Mutual inductive reactance (asynchronous motor)	0.1–6553.5 mH (AC drive power ≤ 55 kW) 0.01–655.35 mH (AC drive power > 55 kW)	Model dependent	★
A3-10	No-load current (asynchronous motor)	0.01 A to A2-03 (AC drive power ≤ 55 kW) 0.1 A to A2-03 (AC drive power > 55 kW)	Model dependent	★
A3-16	Stator resistance (synchronous motor)	0.001–65.535 Ω (AC drive power ≤ 55 kW) 0.0001–6.5535 Ω (AC drive power > 55 kW)	Model dependent	★
A3-17	Shaft D inductance (synchronous motor)	0.01–655.35 mH (AC drive power ≤ 55 kW) 0.001–65.535 mH (AC drive power > 55 kW)	Model dependent	★
A3-18	Shaft Q inductance (synchronous motor)	0.01–655.35 mH (AC drive power ≤ 55 kW) 0.001–65.535 mH (AC drive power > 55 kW)	Model dependent	★
A3-20	Back EMF (synchronous motor)	0.1–6553.5 V	Model dependent	★
A3-27	Encoder pulses per revolution	1–65535	1024	★
A3-28	Encoder type	0: ABZ incremental encoder 1: UVW incremental encoder 2: Resolver 3: SIN/COS encoder 4: Wire-saving UVW encoder	0	★
A3-30	A, B phase sequence of ABZ incremental encoder	0: Forward 1: Reserve	0	★
A3-31	Encoder installation angle	0.0°–359.9°	0.0°	★
A3-32	U, V, W phase sequence of UVW encoder	0: Forward 1: Reverse	0	★
A3-33	UVW encoder angle offset	0.0°–359.9°	0.0°	★

Function Code	Parameter Name	Setting Range	Default	Property
A3-34	Number of pole pairs of resolver	1-65535	1	★
A3-36	Encoder wire-break fault detection time	0.0s: No action 0.1-10.0s	0.0s	★
A3-37	Auto-tuning selection	0: No auto-tuning 1: Asynchronous motor static auto-tuning 2: Asynchronous motor complete auto-tuning 11: Synchronous motor with-load auto-tuning 12: Synchronous motor no-load auto-tuning	0	★
A3-38	Speed loop proportional gain 1	0-100	30	☆
A3-39	Speed loop integral time 1	0.01-10.00s	0.50s	☆
A3-40	Switchover frequency 1	0.00 to A2-43	5.00 Hz	☆
A3-41	Speed loop proportional gain 2	0-100	15	☆
A3-42	Speed loop integral time 2	0.01-10.00s	1.00s	☆
A3-43	Switchover frequency 2	A2-40 to maximum output frequency	10.00 Hz	☆
A3-44	Vector control slip gain	50%-200%	100%	☆
A3-45	Time constant of speed loop filter	0.000-0.100s	0.000s	☆
A3-46	Vector control over-excitation gain	0-200	64	☆
A3-47	Torque upper limit source in speed control mode	0: A2-48 1: AI1 2: AI2 3: AI3 4: Pulse setting (DI5) 5: Via communication 6: MIN (AI1,AI2) 7: MAX (AI1,AI2)	0	☆
A3-48	Digital setting of torque upper limit in speed control mode	0.0%-200.0%	150.0%	☆
A3-51	Excitation adjustment proportional gain	0-20000	2000	☆
A3-52	Excitation adjustment integral gain	0-20000	1300	☆

Function Code	Parameter Name	Setting Range	Default	Property
A3-53	Torque adjustment proportional gain	0-20000	2000	☆
A3-54	Torque adjustment integral gain	0-20000	1300	☆
A3-55	Speed loop integral property	Unit's digit: Integral separated 0: Disabled 1: Enabled	0	☆
A3-56	Field weakening mode of synchronous motor	0: No field weakening 1: Direct calculation 2: Adjustment	0	☆
A3-57	Field weakening degree of synchronous motor	50%-500%	100%	☆
A3-58	Maximum field weakening current	1%-300%	50%	☆
A3-59	Field weakening automatic adjustment gain	10%-500%	100%	☆
A3-60	Field weakening integral multiple	2-10	2	☆
A3-61	Motor 2 control mode	0: Sensorless flux vector control (SFVC) 1: Closed-loop vector control (CLVC) 2: Voltage/Frequency (V/F) control	0	☆
A3-62	Motor 2 acceleration/ deceleration time	0: Same as motor 1 1: Acceleration/Deceleration time 1 2: Acceleration/Deceleration time 2 3: Acceleration/Deceleration time 3 4: Acceleration/Deceleration time 4	0	☆
A3-63	Motor 2 torque boost	0.0%: Automatic torque boost 0.1%-30.0%	Model dependent	☆
A3-65	Motor 2 oscillation suppression gain	0-100	Model dependent	☆
Group A4: Motor 4 Parameters				
A4-00	Motor type selection	0: Common asynchronous motor 1: Variable frequency asynchronous motor 2: Permanent magnetic synchronous motor	0	★
A4-01	Rated motor power	0.1-1000.0 kW	Model dependent	★

Function Code	Parameter Name	Setting Range	Default	Property
A4-02	Rated motor voltage	1–2000 V	Model dependent	★
A4-03	Rated motor current	0.01–655.35 A (AC drive power ≤ 55 kW) 0.1–6553.5 A (AC drive power > 55 kW)	Model dependent	★
A4-04	Rated motor frequency	0.01 Hz to maximum frequency	Model dependent	★
A4-05	Rated motor rotational speed	1–65535 RPM	Model dependent	★
A4-06	Stator resistance (asynchronous motor)	0.001–65.535 Ω (AC drive power ≤ 55 kW) 0.0001–6.5535 Ω (AC drive power > 55 kW)	Model dependent	★
A4-07	Rotor resistance (asynchronous motor)	0.001–65.535 Ω (AC drive power ≤ 55 kW) 0.0001–6.5535 Ω (AC drive power > 55 kW)	Model dependent	★
A4-08	Leakage inductive reactance (asynchronous motor)	0.01–655.35 mH (AC drive power ≤ 55 kW) 0.001–65.535 mH (AC drive power > 55 kW)	Model dependent	★
A4-09	Mutual inductive reactance (asynchronous motor)	0.1–6553.5 mH (AC drive power ≤ 55 kW) 0.01–655.35 mH (AC drive power > 55 kW)	Model dependent	★
A4-10	No-load current (asynchronous motor)	0.01 A to A2-03 (AC drive power ≤ 55 kW) 0.1 A to A2-03 (AC drive power > 55 kW)	Model dependent	★
A4-16	Stator resistance (synchronous motor)	0.001–65.535 Ω (AC drive power ≤ 55 kW) 0.0001–6.5535 Ω (AC drive power > 55 kW)	Model dependent	★
A4-17	Shaft D inductance (synchronous motor)	0.01–655.35 mH (AC drive power ≤ 55 kW) 0.001–65.535 mH (AC drive power > 55 kW)	Model dependent	★
A4-18	Shaft Q inductance (synchronous motor)	0.01–655.35 mH (AC drive power ≤ 55 kW) 0.001–65.535 mH (AC drive power > 55 kW)	Model dependent	★

Function Code	Parameter Name	Setting Range	Default	Property
A4-20	Back EMF (synchronous motor)	0.1–6553.5 V	Model dependent	★
A4-27	Encoder pulses per revolution	1–65535	1024	★
A4-28	Encoder type	0: ABZ incremental encoder 1: UVW incremental encoder 2: Resolver 3: SIN/COS encoder 4: Wire-saving UVW encoder	0	★
A4-30	A, B phase sequence of ABZ incremental encoder	0: Forward 1: Reserve	0	★
A4-31	Encoder installation angle	0.0°–359.9°	0.0°	★
A4-32	U, V, W phase sequence of UVW encoder	0: Forward 1: Reverse	0	★
A4-33	UVW encoder angle offset	0.0°–359.9°	0.0°	★
A4-34	Number of pole pairs of resolver	1–65535	1	★
A4-36	Encoder wire-break fault detection time	0.0s: No action 0.1–10.0s	0.0s	★
A4-37	Auto-tuning selection	0: No auto-tuning 1: Asynchronous motor static auto-tuning 2: Asynchronous motor complete auto-tuning 11: Synchronous motor with-load auto-tuning 12: Synchronous motor no-load auto-tuning	0	★
A4-38	Speed loop proportional gain 1	0–100	30	☆
A4-39	Speed loop integral time 1	0.01–10.00s	0.50s	☆
A4-40	Switchover frequency 1	0.00 to A2-43	5.00 Hz	☆
A4-41	Speed loop proportional gain 2	0–100	15	☆
A4-42	Speed loop integral time 2	0.01–10.00s	1.00s	☆
A4-43	Switchover frequency 2	A2-40 to maximum output frequency	10.00 Hz	☆
A4-44	Vector control slip gain	50%–200%	100%	☆
A4-45	Time constant of speed loop filter	0.000–0.100s	0.000s	☆

Function Code	Parameter Name	Setting Range	Default	Property
A4-46	Vector control over-excitation gain	0-200	64	☆
A4-47	Torque upper limit source in speed control mode	0: A2-48 1: AI1 2: AI2 3: AI3 4: Pulse setting (DI5) 5: Via communication 6: MIN(AI1,AI2) 7: MIN(AI1,AI2)	0	☆
A4-48	Digital setting of torque upper limit in speed control mode	0.0%-200.0%	150.0%	☆
A4-51	Excitation adjustment proportional gain	0-20000	2000	☆
A4-52	Excitation adjustment integral gain	0-20000	1300	☆
A4-53	Torque adjustment proportional gain	0-20000	2000	☆
A4-54	Torque adjustment integral gain	0-20000	1300	☆
A4-55	Speed loop integral property	Unit's digit: Integral separated 0: Disabled 1: Enabled	0	☆
A4-56	Field weakening mode of synchronous motor	0: No field weakening 1: Direct calculation 2: Adjustment	0	☆
A4-57	Field weakening degree of synchronous motor	50%-500%	100%	☆
A4-58	Maximum field weakening current	1%-300%	50%	☆
A4-59	Field weakening automatic adjustment gain	10%-500%	100%	☆
A4-60	Field weakening integral multiple	2-10	2	☆
A4-61	Motor 2 control mode	0: Sensorless flux vector control (SFVC) 1: Closed-loop vector control (CLVC) 2: Voltage/Frequency (V/F) control	0	☆

Function Code	Parameter Name	Setting Range	Default	Property
A4-62	Motor 2 acceleration/ deceleration time	0: Same as motor 1 1: Acceleration/Deceleration time 1 2: Acceleration/Deceleration time 2 3: Acceleration/Deceleration time 3 4: Acceleration/Deceleration time 4	0	☆
A4-63	Motor 2 torque boost	0.0%: Automatic torque boost 0.1%–30.0%	Model dependent	☆
A4-65	Motor 2 oscillation suppression gain	0–100	Model dependent	☆
Group A5: Control Optimization Parameters				
A5-00	DPWM switchover frequency upper limit	0.00–15.00 Hz	12.00 Hz	☆
A5-01	PWM modulation mode	0: Asynchronous modulation 1: Synchronous modulation	0	☆
A5-02	Dead zone compensation mode selection	0: No compensation 1: Compensation mode 1 2: Compensation mode 2	1	☆
A5-03	Random PWM depth	0: Random PWM invalid 1–10	0	☆
A5-04	Rapid current limit	0: Disabled 1: Enabled	1	☆
A5-05	Current detection compensation	0–100	5	☆
A5-06	Undervoltage threshold	60.0%–140.0%	100.0%	☆
A5-07	SFVC optimization mode selection	0: No optimization 1: Optimization mode 1 2: Optimization mode 2	1	☆
A5-08	Dead-zone time adjustment	100%–200%	150%	☆
A5-09	Overvoltage threshold	200.0–2500.0 V	2000.0 V	☆
Group A6: AI Curve Setting				
A6-00	AI curve 4 minimum input	-10.00 V to A6-02	0.00 V	☆
A6-01	Corresponding setting of AI curve 4 minimum input	-100.0%–100.0%	0.0%	☆
A6-02	AI curve 4 inflexion 1 input	A6-00 to A6-04	3.00 V	☆
A6-03	Corresponding setting of AI curve 4 inflexion 1 input	-100.0%–100.0%	30.0%	☆
A6-04	AI curve 4 inflexion 1 input	A6-02 to A6-06	6.00 V	☆
A6-05	Corresponding setting of AI curve 4 inflexion 1 input	-100.0%–100.0%	60.0%	☆
A6-06	AI curve 4 maximum input	A6-06 to 10.00 V	10.00 V	☆

Function Code	Parameter Name	Setting Range	Default	Property
A6-07	Corresponding setting of AI curve 4 maximum input	-100.0%–100.0%	100.0%	☆
A6-08	AI curve 5 minimum input	-10.00 V to A6-10	0.00 V	☆
A6-09	Corresponding setting of AI curve 5 minimum input	-100.0%–100.0%	0.0%	☆
A6-10	AI curve 5 inflexion 1 input	A6-08 to A6-12	3.00 V	☆
A6-11	Corresponding setting of AI curve 5 inflexion 1 input	-100.0%–100.0%	30.0%	☆
A6-12	AI curve 5 inflexion 1 input	A6-10 to A6-14	6.00 V	☆
A6-13	Corresponding setting of AI curve 5 inflexion 1 input	-100.0%–100.0%	60.0%	☆
A6-14	AI curve 5 maximum input	A6-14 to 10.00 V	10.00 V	☆
A6-15	Corresponding setting of AI curve 5 maximum input	-100.0%–100.0%	100.0%	☆
A6-16	Jump point of AI1 input corresponding setting	-100.0%–100.0%	0.0%	☆
A6-17	Jump amplitude of AI1 input corresponding setting	0.0%–100.0%	0.5%	☆
A6-18	Jump point of AI2 input corresponding setting	-100.0%–100.0%	0.0%	☆
A6-19	Jump amplitude of AI2 input corresponding setting	0.0%–100.0%	0.5%	☆
A6-20	Jump point of AI3 input corresponding setting	-100.0%–100.0%	0.0%	☆
A6-21	Jump amplitude of AI3 input corresponding setting	0.0%–100.0%	0.5%	☆
Group A7: User Programmable Function				
A7-00	User programmable function selection	0: Disabled 1: Enabled	0	★

Function Code	Parameter Name	Setting Range	Default	Property
A7-01	Selection of control mode of the output terminals on the control board	Unit's digit: FMR (FM used as digital output)	0	★
		0: Controlled by the AC drive 1: Controlled by the user programmable card		
		Ten's digit: relay (T/A-T/B-T/C)		
		Same as unit's digit		
		Hundred's digit: DO1		
		Same as unit's digit		
		Thousand's digit FMR (FM used as pulse output)		
		Same as unit's digit		
		Ten thousand's digit: AO1		
		Same as unit's digit		
A7-02	AI/AO function selection of the user programmable card	0: AI3 (voltage input), AO2 (voltage output)	0	★
		1: AI3 (voltage input), AO2 (current output)		
		2: AI3 (current input), AO2 (voltage output)		
		3: AI3 (current input), AO2 (current output)		
		4: AI3 (PTC input), AO2 (voltage output)		
		5: AI3 (PTC input), AO2 (current output)		
		6: AI3 (PTC100 input), AO2 (voltage output)		
		7: AI3 (PTC100 input), AO2 (current output)		
A7-03	FMP output	0.0%–100.0%	0.0%	☆
A7-04	AO1 output	0.0%–100.0%	0.0%	☆
A7-05	Digital output	Binary setting	1	☆
		Unit's digit: FMR		
		Ten's digit: Relay1 Hundred's digit: DO		
A7-06	Frequency setting through the user programmable card	-100.00% to 100.00%	0.0%	☆
A7-07	Torque setting through the user programmable card	-200.00% to 200.00%	0.0%	☆

Function Code	Parameter Name	Setting Range	Default	Property
A7-08	Command given by the user programmable card	1: Forward RUN 2: Reverse RUN 3: Forward JOG 4: Reverse JOG 5: Coast to stop 6: Decelerate to stop 7: Fault reset	0	☆
A7-09	Faults given by the user programmable card	0: No fault 80-89: Fault codes	0	☆
Group A8: Point-point Communication				
A8-00	Point-point communication selection	0: Disabled 1: Enabled	0	☆
A8-01	Master and slave selection	0: Master 1: Slave	0	☆
A8-02	Slave following master command selection	0: Slave not following running commands of the master 1: Slave following running commands of the master	0	☆
A8-03	Usage of data received by slave	0: Torque setting 1: Frequency setting	0	☆
A8-04	Zero offset of received data (torque)	-100.00%~100.00%	0.00%	★
A8-05	Gain of received data (torque)	-10.00~10.00	1.00	★
A8-06	Point-point communication interruption detection time	0.0~10.0s	1.0s	☆
A8-07	Master data sending cycle	0.001~10.000s	0.001s	☆
A8-08	Zero offset of received data zero offset (frequency)	-100.00%~100.00%	0.00%	★
A8-09	Gain of received data gain (frequency)	-10.00~10.00	1.00	★
A8-10	Runaway prevention coefficient	0.00%~100.00%	10.00%	★
Group AC: AI/AO Correction				
AC-00	AI1 measured voltage 1	0.500~4.000 V	Factory corrected	☆
AC-01	AI1 displayed voltage 1	0.500~4.000 V	Factory corrected	☆
AC-02	AI1 measured voltage 2	6.000~9.999 V	Factory corrected	☆

Function Code	Parameter Name	Setting Range	Default	Property
AC-03	AI1 displayed voltage 2	6.000–9.999 V	Factory corrected	☆
AC-04	AI2 measured voltage 1	0.500–4.000 V	Factory corrected	☆
AC-05	AI2 displayed voltage 1	0.500–4.000 V	Factory corrected	☆
AC-06	AI2 measured voltage 2	6.000–9.999 V	Factory corrected	☆
AC-07	AI2 displayed voltage 2	9.999–10.000 V	Factory corrected	☆
AC-08	AI3 measured voltage 1	9.999–10.000 V	Factory corrected	☆
AC-09	AI3 displayed voltage 1	9.999–10.000 V	Factory corrected	☆
AC-10	AI3 measured voltage 2	9.999–10.000 V	Factory corrected	☆
AC-11	AI3 displayed voltage 2	9.999–10.000 V	Factory corrected	☆
AC-12	AO1 target voltage 1	0.500–4.000 V	Factory corrected	☆
AC-13	AO1 measured voltage 1	0.500–4.000 V	Factory corrected	☆
AC-14	AO1 target voltage 2	6.000–9.999 V	Factory corrected	☆
AC-15	AO1 measured voltage 2	6.000–9.999 V	Factory corrected	☆
AC-16	AO2 target voltage 1	0.500–4.000 V	Factory corrected	☆
AC-17	AO2 measured voltage 1	0.500–4.000 V	Factory corrected	☆
AC-18	AO2 target voltage 2	6.000–9.999 V	Factory corrected	☆
AC-19	AO2 measured voltage 2	6.000–9.999 V	Factory corrected	☆
AC-20	AI2 measured current 1	0.000–20.000 mA	Factory corrected	☆
AC-21	AI2 sampling current 1	0.000–20.000 mA	Factory corrected	☆
AC-22	AI2 measured current 2	0.000–20.000 mA	Factory corrected	☆
AC-23	AI2 sampling current 2	0.000–20.000 mA	Factory corrected	☆

Function Code	Parameter Name	Setting Range	Default	Property
AC-24	AO1 ideal current 1	0.000–20.000 mA	Factory corrected	☆
AC-25	AO1 sampling current 1	0.000–20.000 mA	Factory corrected	☆
AC-26	AO1 ideal current 2	0.000–20.000 mA	Factory corrected	☆
AC-27	AO1 sampling current 2	0.000–20.000 mA	Factory corrected	☆

5.2 Monitoring Parameters

Function Code	Parameter Name	Min. Unit	Communication Address
Group U0: Standard Monitoring Parameters			
U0-00	Running frequency (Hz)	0.01 Hz	7000H
U0-01	Set frequency (Hz)	0.01 Hz	7001H
U0-02	Bus voltage	0.1 V	7002H
U0-03	Output voltage	1 V	7003H
U0-04	Output current	0.01 A	7004H
U0-05	Output power	0.1 kW	7005H
U0-06	Output torque	0.1%	7006H
U0-07	DI state	1	7007H
U0-08	DO state	1	7008H
U0-09	AI1 voltage (V)	0.01 V	7009H
U0-10	AI2 voltage (V)/current (mA)	0.01 V/0.01 mA	700AH
U0-11	AI3 voltage (V)	0.01 V	7007BH
U0-12	Count value	1	700CH
U0-13	Length value	1	700DH
U0-14	Load speed	1	700EH
U0-15	PID setting	1	700FH
U0-16	PID feedback	1	7010H
U0-17	PLC stage	1	7011H
U0-18	Input pulse frequency (Hz)	0.01 kHz	7012H
U0-19	Feedback speed	0.01 Hz	7013H
U0-20	Remaining running time	0.1 Min	7014H
U0-21	AI1 voltage before correction	0.001 V	7015H
U0-22	AI2 voltage (V)/current (mA) before correction	0.01 V/0.01 mA	7016H

Function Code	Parameter Name	Min. Unit	Communication Address
Group U0: Standard Monitoring Parameters			
U0-23	AI3 voltage before correction	0.001 V	7017H
U0-24	Linear speed	1 m/Min	7018H
U0-25	Accumulative power-on time	1 Min	7019
U0-26	Accumulative running time	0.1 Min	701AH
U0-27	Pulse input frequency	1 Hz	701BH
U0-28	Communication setting value	0.01%	701CH
U0-29	Encoder feedback speed	0.01 Hz	701DH
U0-30	Main frequency X	0.01 Hz	701EH
U0-31	Auxiliary frequency Y	0.01 Hz	701FH
U0-32	Viewing any register address value	1	7020H
U0-33	Synchronous motor rotor position	0.1°	7021H
U0-34	Motor temperature	1°C	7022H
U0-35	Target torque	0.1%	7023H
U0-36	Resolver position	1	7024H
U0-37	Power factor angle	0.1°	7025H
U0-38	ABZ position	1	7026H
U0-39	Target voltage upon V/F separation	1 V	7027H
U0-40	Output voltage upon V/F separation	1V	7028H
U0-41	DI state visual display	1	7029H
U0-42	DO state visual display	1	702AH
U0-43	DI function state visual display 1	1	702BH
U0-44	DI function state visual display 2	1	702CH
U0-45	Fault information	1	702DH
U0-58	Phase Z counting	1	703AH
U0-59	Current set frequency	0.01%	703BH
U0-60	Current running frequency	0.01%	703CH
U0-61	AC drive running state	1	703DH
U0-62	Current fault code	1	703EH
U0-63	Sent value of point-point communication	0.01%	703FH
U0-64	Received value of point-point communication	0.01%	7040H
U0-65	Torque upper limit	0.1%	7041H



Description of Function Codes

Chapter 6 Description of Function Codes

Group F0: Basic Parameters

Function Code	Parameter Name	Setting Range	Default
F0-00	G/P type display	1: G type (constant torque load) 2: P type (variable torque load e.g. fan and pump)	Model dependent

This parameter is used to display the delivered model and cannot be modified.

- 1: Applicable to constant torque load with rated parameters specified
- 2: Applicable to variable torque load (fan and pump) with rated parameters specified

Function Code	Parameter Name	Setting Range	Default
F0-01	Motor 1 control mode	0: Sensorless flux vector control (SFVC) 1: Closed-loop vector control (CLVC) 2: Voltage/Frequency (V/F) control	0

- 0: Sensorless flux vector control (SFVC)

It indicates open-loop vector control, and is applicable to high-performance control applications such as machine tool, centrifuge, wire drawing machine and injection moulding machine. One AC drive can operate only one motor.

- 1: Closed-loop vector control (CLVC)

It is applicable to high-accuracy speed control or torque control applications such as high-speed paper making machine, crane and elevator. One AC drive can operate only one motor. An encoder must be installed at the motor side, and a PG card matching the encoder must be installed at the AC drive side.

- 2: Voltage/Frequency (V/F) control

It is applicable to applications with low load requirements or applications where one AC drive operates multiple motors, such as fan and pump.

Note

- If vector control is used, motor auto-tuning must be performed because the advantages of vector control can only be utilized after correct motor parameters are obtained. Better performance can be achieved by adjusting speed regulator parameters in group F2 (or groups A2, A3, and A4 respectively for motor 2, 3, and 4).
- For the permanent magnetic synchronous motor (PMSM), the MD380 does not support SFVC. CLVC is used generally. In some low-power motor applications, you can also use V/F.

Function Code	Parameter Name	Setting Range	Default
F0-02	Command source selection	0: Operation panel control (LED off) 1: Terminal control (LED on) 2: Communication control (LED blinking)	0

It is used to determine the input channel of the AC drive control commands, such as run, stop, forward rotation, reverse rotation and jog operation. You can input the commands in the following three channels:

- 0: Operation panel control ("LOCAL/REMOT" indicator off)

Commands are given by pressing keys  and  on the operation panel.

- 1: Terminal control ("LOCAL/REMOT" indicator on)

Commands are given by means of multifunctional input terminals with functions such as FWD, REV, JOGF, and JOGR.

- 2: Communication control ("LOCAL/REMOT" indicator blinking)



Commands are given from host computer. If this parameter is set to 2, a communication card (Modbus RTU, PROFIBUS-DP card, CANlink card, user programmable card or CANopen card) must be installed.

- If a PROFIBUS-DP card is selected and PZD1 data is valid, commands are given by means of PZD1 data.
- If a user programmable card is selected, commands are written to A7-08 by means of the programmable card.
- If any other card is selected, commands are written by means of the communication address 0x2000.

Function Code	Parameter Name	Setting Range	Default
F0-03	Main frequency source X selection	0: Digital setting (non-retentive at power failure) 1: Digital setting (retentive at power failure) 2: AI1 3: AI2 4: AI3 5: Pulse setting (DI5) 6: Multi-reference 7: Simple PLC 8: PID 9: Communication setting	0



It is used to select the setting channel of the main frequency. You can set the main frequency in the following 10 channels:

- 0: Digital setting (non-retentive at power failure)

The initial value of the set frequency is the value of F0-08 (Preset frequency). You can change the set frequency by pressing  and  on the operation panel (or using the UP/DOWN function of input terminals).

When the AC drive is powered on again after power failure, the set frequency reverts to the value of F0-08.

- 1: Digital setting (retentive at power failure)

The initial value of the set frequency is the value of F0-08 (Preset frequency). You can change the set frequency by pressing keys  and  on the operation panel (or using the UP/DOWN function of input terminals).

When the AC drive is powered on again after power failure, the set frequency is the value memorized at the moment of the last power failure.

Note that F0-23 (Retentive of digital setting frequency upon power failure) determines whether the set frequency is memorized or cleared when the AC drive stops. It is related to stop rather than power failure.

- 2: AI1 (0–10 V voltage input)
- 3: AI2 (0–10 V voltage input or 4–20 mA current input, determined by jumper J8)
- 4: AI3 (0–10 V voltage input)

The frequency is set by analog input. The MD380 control board provides two analog input (AI) terminals (AI1, AI2). Another AI terminal (AI3) is provided by the I/O extension card.

The MD380 provides five curves indicating the mapping relationship between the input voltage of AI1, AI2 and AI3 and the target frequency, three of which are linear (point-point) correspondence and two of which are four-point correspondence curves. You can set the curves by using function codes F4-13 to F4-27 and function codes in group A6, and select curves for AI1, AI2 and AI3 in F4-33.

When AI is used as the frequency setting source, the corresponding value 100% of the voltage/current input corresponds to the value of F0-10 (Maximum frequency).

- 5: Pulse setting (DI5)

The frequency is set by DI5 (high-speed pulse). The signal specification of pulse setting is 9–30 V (voltage range) and 0–100 kHz (frequency range). The corresponding value 100% of pulse setting corresponds to the value of F0-10 (Maximum frequency).

- 6: Multi-reference

In multi-reference mode, combinations of different DI terminal states correspond to different set frequencies. The MD380 supports a maximum of 16 speeds implemented by 16 state combinations of four DI terminals (allocated with functions 12 to 15) in Group FC. The multiple references indicate percentages of the value of F0-10 (Maximum frequency).

If a DI terminal is used for the multi-reference function, you need to perform related setting in group F4.

- 7: Simple PLC

When the simple programmable logic controller (PLC) mode is used as the frequency source, the running frequency of the AC drive can be switched over among the 16 frequency references. You can set the holding time and acceleration/deceleration time of the 16 frequency references. For details, refer to the descriptions of Group FC.

- 8: PID

The output of PID control is used as the running frequency. PID control is generally used in on-site closed-loop control, such as constant pressure closed-loop control and constant tension closed-loop control.

When applying PID as the frequency source, you need to set parameters of PID function in group FA.

- 9: Communication setting

The frequency is set by means of communication.

If the AC drive is a slave in point-point communication and receives data as the frequency source, data transmitted by the master is used as the set frequency. For details, see the description of group A8.

If PROFIBUS-DP communication is valid and PZD1 is used for frequency setting, data transmitted by PDZ1 is directly used as the frequency source. The data format is -100.00% to 100.00%. 100% corresponds to the value of F0-10 (Maximum frequency).

In other conditions, data is given by the host computer through the communication address 0x1000. The data format is -100.00% to 100.00%. 100.00% corresponds to the value of F0-10 (Maximum frequency).

The MD380 supports four host computer communication protocols: Modbus, PROFIBUS-DP, CANopen and CANlink. They cannot be used simultaneously.



If the communication mode is used, a communication card must be installed. The MD380 provides four optional communication cards and you can select one based on actual requirements. If the communication protocol is Modbus, PROFIBUS-DP or CANopen, the corresponding serial communication protocol needs to be selected based on the setting of F0-28.

The CANlink protocol is always valid.

Function Code	Parameter Name	Setting Range	Default
F0-04	Auxiliary frequency source Y selection	0: Digital setting (non-retentive at power failure) 1: Digital setting (retentive at power failure) 2: AI1 3: AI2 4: AI3 5: Pulse setting (DI5) 6: Multi-reference 7: Simple PLC 8: PID 9: Communication setting	0

When used as an independent frequency input channel (frequency source switched over from X to Y), the auxiliary frequency source Y is used in the same way as the main frequency source X (refer to F0-03).

When the auxiliary frequency source is used for operation (frequency source is "X and Y operation"), pay attention to the following aspects:

- 1) If the auxiliary frequency source Y is digital setting, the preset frequency (F0-08) does not take effect. You can directly adjust the set main frequency by pressing keys  and  on the operation panel (or using the UP/DOWN function of input terminals).
- 2) If the auxiliary frequency source is analog input (AI1, AI2 and AI3) or pulse setting, 100% of the input corresponds to the range of the auxiliary frequency Y (set in F0-05 and F0-06).
- 3) If the auxiliary frequency source is pulse setting, it is similar to analog input.

Note

The main frequency source X and auxiliary frequency source Y must not use the same channel. That is, F0-03 and F0-04 cannot be set to the same value.

Function Code	Parameter Name	Setting Range	Default
F0-05	Range of auxiliary frequency Y for X and Y operation	0: Relative to maximum frequency 1: Relative to main frequency X	0
F0-06	Range of auxiliary frequency Y for X and Y operation	0%–150%	0

If X and Y operation is used, F0-05 and F0-06 are used to set the adjustment range of the auxiliary frequency source.

You can set the auxiliary frequency to be relative to either maximum frequency or main frequency X. If relative to main frequency X, the setting range of the auxiliary frequency Y varies according to the main frequency X.

Function Code	Parameter Name	Setting Range	Default
F0-07	Frequency source selection	Unit's digit (Frequency source selection)	0
		0: Main frequency source X 1: X and Y operation (operation relationship determined by ten's digit) 2: Switchover between X and Y 3: Switchover between X and "X and Y operation" 4: Switchover between Y and "X and Y operation"	
		Ten's digit (X and Y operation relationship)	
		0: X+Y 1: X-Y 2: Maximum 3: Minimum	

It is used to select the frequency setting channel. If the frequency source involves X and Y operation, you can set the frequency offset in F0-21 for superposition to the X and Y operation result, flexibly satisfying various requirements.

Figure 6-1 Frequency setting based on main frequency source X and auxiliary frequency source Y

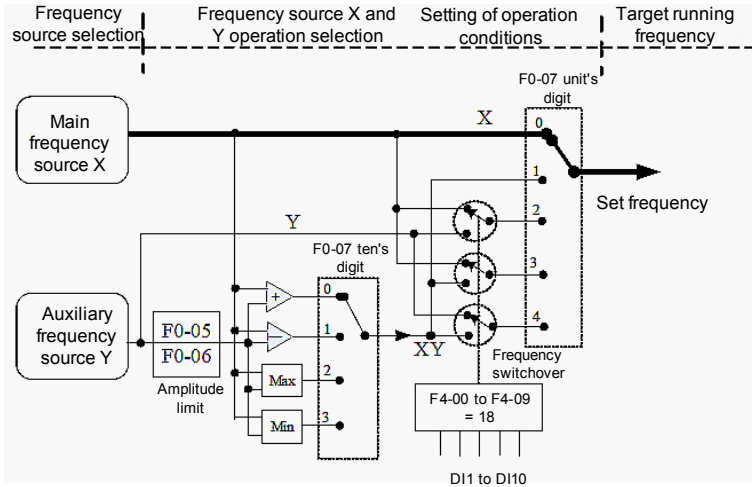

Function Code	Parameter Name	Setting Range	Default
F0-08	Preset frequency	0.00 to maximum frequency (valid when frequency source is digital setting)	50 Hz

If the frequency source is digital setting or terminal UP/DOWN, the value of this parameter is the initial frequency of the AC drive (digital setting).

Function Code	Parameter Name	Setting Range	Default
F0-09	Rotation direction	0: Same direction 1: Reverse direction	0

You can change the rotation direction of the motor just by modifying this parameter without changing the motor wiring. Modifying this parameter is equivalent to exchanging any two of the motor's U, V, W wires.

Note

The motor will resume running in the original direction after parameter initialization. Do not use this function in applications where changing the rotating direction of the motor is prohibited after system commissioning is complete.

Function Code	Parameter Name	Setting Range	Default
F0-10	Maximum frequency	50.00–320.00 Hz	50.00 Hz

When the frequency source is AI, pulse setting (DI5), or multi-reference, 100% of the input corresponds to the value of this parameter.

The output frequency of the MD380 can reach up to 3200 Hz. To take both frequency reference resolution and frequency input range into consideration, you can set the number of decimal places for frequency reference in F0-22.

- If F0-22 is set to 1, the frequency reference resolution is 0.1 Hz. In this case, the setting range of F0-10 is 50.0 to 3200.0 Hz.
- If F0-22 is set to 2, the frequency reference resolution is 0.01 Hz. In this case, the setting range of F0-10 is 50.00 to 320.00 Hz.

Note

After the value of F0-22 is modified, the frequency resolution of all frequency related function codes change accordingly.

Function Code	Parameter Name	Setting Range	Default
F0-11	Source of frequency upper limit	0: Set by F0-12 1: AI1 2: AI2 3: AI3 4: Pulse setting (DI5) 5: Communication setting	0

It is used to set the source of the frequency upper limit, including digital setting (F0-12), AI, pulse setting or communication setting. If the frequency upper limit is set by means of AI1, AI2, AI3, DI5 or communication, the setting is similar to that of the main frequency source X. For details, see the description of F0-03.

For example, to avoid runaway in torque control mode in winding application, you can set the frequency upper limit by means of analog input. When the AC drive reaches the upper limit, it will continue to run at this speed.

Function Code	Parameter Name	Setting Range	Default
F0-12	Frequency upper limit	Frequency lower limit (F0-14) to maximum frequency (F0-10)	50.00 Hz

This parameter is used to set the frequency upper limit.

Function Code	Parameter Name	Setting Range	Default
F0-13	Frequency upper limit offset	0.00 Hz to maximum frequency (F0-10)	0.00 Hz

If the source of the frequency upper limit is analog input or pulse setting, the final frequency upper limit is obtained by adding the offset in this parameter to the frequency upper limit set in F0-11.

Function Code	Parameter Name	Setting Range	Default
F0-14	Frequency lower limit	0.00 Hz to frequency upper limit (F0-12)	0.00 Hz

If the frequency reference is lower than the value of this parameter, the AC drive can stop, run at the frequency lower limit, or run at zero speed, determined by F8-14.

Function Code	Parameter Name	Setting Range	Default
F0-15	Carrier frequency	0.5–16.0 kHz	Model dependent

It is used to adjust the carrier frequency of the AC drive, helping to reduce the motor noise, avoiding the resonance of the mechanical system, and reducing the leakage current to the earth and interference generated by the AC drive.

If the carrier frequency is low, output current has high harmonics, and the power loss and temperature rise of the motor increase.

If the carrier frequency is high, power loss and temperature rise of the motor declines. However, the AC drive has an increase in power loss, temperature rise and interference.

Adjusting the carrier frequency will exert influences on the aspects listed in the following table.

Table 6-1 Influences of carrier frequency adjustment

Carrier frequency	Low	High
Motor noise	Large	Small
Output current waveform	Bad	Good
Motor temperature rise	High	Low
AC drive temperature rise	Low	High
Leakage current	Small	Large
External radiation interference	Small	Large

The factory setting of carrier frequency varies with the AC drive power. If you need to modify the carrier frequency, note that if the set carrier frequency is higher than factory setting, it will lead to an increase in temperature rise of the AC drive's heatsink. In this case, you need to de-rate the AC drive. Otherwise, the AC drive may overheat and alarm.

Function Code	Parameter Name	Setting Range	Default
F0-16	Carrier frequency adjustment with temperature	0: No 1: Yes	1

It is used to set whether the carrier frequency is adjusted based on the temperature. The AC drive automatically reduces the carrier frequency when detecting that the heatsink temperature is high. The AC drive resumes the carrier frequency to the set value when the heatsink temperature becomes normal. This function reduces the overheat alarms.

Function Code	Parameter Name	Setting Range	Default
F0-17	Acceleration time 1	0.00–650.00s (F0-19 = 2) 0.0–6500.0s (F0-19 = 1) 0–65000s (F0-19 = 0)	Model dependent
F0-18	Deceleration time 1	0.00–650.00s (F0-19 = 2) 0.0–6500.0s (F0-19 = 1) 0–65000s (F0-19 = 0)	Model dependent

Acceleration time indicates the time required by the AC drive to accelerate from 0 Hz to "Acceleration/Deceleration base frequency" (F0-25), that is, t1 in Figure 6-2.

Deceleration time indicates the time required by the AC drive to decelerate from "Acceleration/Deceleration base frequency" (F0-25) to 0 Hz, that is, t2 in Figure 6-2.

Figure 6-2 Acceleration/Deceleration time

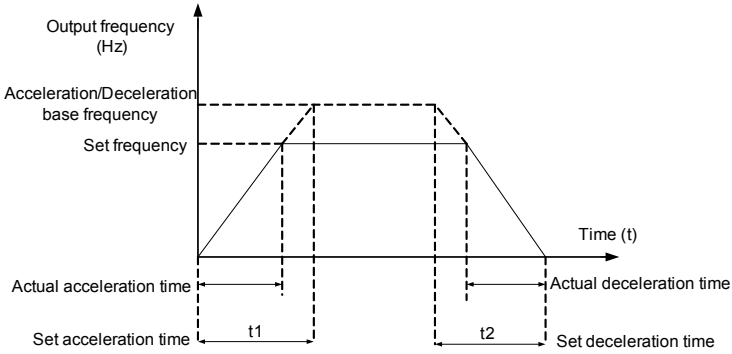

The MD380 provides totally four groups of acceleration/deceleration time for selection. You can perform switchover by using a DI terminal.

- Group 1: F0-17, F0-18
- Group 2: F8-03, F8-04
- Group 3: F8-05, F8-06
- Group 4: F8-07, F8-08

Function Code	Parameter Name	Setting Range	Default
F0-19	Acceleration/Deceleration time unit	0:1s 1: 0.1s 2: 0.01s	1

To satisfy requirements of different applications, the MD380 provides three acceleration/deceleration time units, 1s, 0.1s and 0.01s.

Note

Modifying this parameter will make the displayed decimal places change and corresponding acceleration/deceleration time also change.

Function Code	Parameter Name	Setting Range	Default
F0-21	Frequency offset of auxiliary frequency source for X and Y operation	0.00 Hz to maximum frequency (F0-10)	0.00 Hz

This parameter is valid only when the frequency source is set to "X and Y operation". The final frequency is obtained by adding the frequency offset set in this parameter to the X and Y operation result.

Function Code	Parameter Name	Setting Range	Default
F0-22	Frequency reference resolution	1: 0.1 Hz 2: 0.01 Hz	2

It is used to set the resolution of all frequency-related parameters.



If the resolution is 0.1 Hz, the MD380 can output up to 3200 Hz. If the resolution is 0.01 Hz, the MD380 can output up to 600.00 Hz.



Note

- Modifying this parameter will make the decimal places of all frequency-related parameters change and corresponding frequency values change.
- This parameter is not resumed when factory setting is resumed.

Function Code	Parameter Name	Setting Range	Default
F0-23	Retentive of digital setting frequency upon power failure	0: Not retentive 1: Retentive	0

This parameter is valid only when the frequency source is digital setting.

If F0-23 is set to 0, the digital setting frequency value resumes to the value of F0-08 (Preset frequency) after the AC drive stops. The modification by using keys  and  or the terminal UP/DOWN function is cleared.

If F0-23 is set to 1, the digital setting frequency value is the set frequency at the moment when the AC drive stops. The modification by using keys  and  or the terminal UP/DOWN function remains effective.

Function Code	Parameter Name	Setting Range	Default
F0-24	Motor parameter group selection	0: Motor parameter group 1 1: Motor parameter group 2 2: Motor parameter group 3 3: Motor parameter group 4	0

The MD380 can drive four motors at different time. You can set the motor nameplate parameters respectively, independent motor auto-tuning, different control modes, and parameters related to running performance respectively for the four motors.

Motor parameter group 1 corresponds to groups F1 and F2. Motor parameter groups 2, 3 and 4 correspond to groups A2, A3 and A4 respectively.



You can select the current motor parameter group by using F0-24 or perform switchover between the motor parameter groups by means of a DI terminal. If motor parameters selected by means of F0-24 conflict with those selected by means of DI terminal, the selection by DI is preferred.

Function Code	Parameter Name	Setting Range	Default
F0-25	Acceleration/Deceleration time base frequency	0: Maximum frequency (F0-10) 1: Set frequency 2: 100 Hz	0

The acceleration/deceleration time indicates the time for the AC drive to increase from 0 Hz to the frequency set in F0-25. If this parameter is set to 1, the acceleration/deceleration time is related to the set frequency. If the set frequency changes frequently, the motor's acceleration/deceleration also changes.

Function Code	Parameter Name	Setting Range	Default
F0-26	Base frequency for UP/DOWN modification during running	0: Running frequency 1: Set frequency	0

This parameter is valid only when the frequency source is digital setting.

It is used to set the base frequency to be modified by using keys  and  or the terminal UP/DOWN function. If the running frequency and set frequency are different, there will be a large difference between the AC drive's performance during the acceleration/ deceleration process.

Function Code	Parameter Name	Setting Range	Default
F0-27	Binding command source to frequency source	Unit's digit (Binding operation panel command to frequency source)	000
		0: No binding 1: Frequency source by digital setting 2: AI1 3: AI2 4: AI3 5: Pulse setting (DI5) 6: Multi-reference 7: Simple PLC 8: PID 9: Communication setting	
		Ten's digit (Binding terminal command to frequency source)	
		0-9, same as unit's digit	
		Hundred's digit (Binding communication command to frequency source)	
		0-9, same as unit's digit)	

It is used to bind the three running command sources with the nine frequency sources, facilitating to implement synchronous switchover.

For details on the frequency sources, see the description of F0-03 (Main frequency source X selection). Different running command sources can be bound to the same frequency source.

If a command source has a bound frequency source, the frequency source set in F0-03 to F0-07 no longer takes effect when the command source is effective.

Function Code	Parameter Name	Setting Range	Default
F0-28	Serial communication protocol	0: Modbus protocol 1: PROFIBUS-DP bridge 2: CANopen bridge	0

The MD380 supports Modbus, PROFIBUS-DP bridge and CANopen bridge. Select a proper protocol based on the actual requirements.

Group F1: Motor 1 Parameters

Function Code	Parameter Name	Setting Range	Default
F1-00	Motor type selection	0: Common asynchronous motor 1: Variable frequency asynchronous motor 2: Permanent magnetic synchronous motor	1
F1-01	Rated motor power	0.1–1000.0 kW	Model dependent
F1-02	Rated motor voltage	1–2000 V	Model dependent
F1-03	Rated motor current	0.01–655.35 A (AC drive power ≤ 55 kW) 0.1–6553.5 A (AC drive power > 55 kW)	Model dependent
F1-04	Rated motor frequency	0.01 Hz to maximum frequency	Model dependent
F1-05	Rated motor rotational speed	1–65535 RPM	Model dependent

Set the parameters according to the motor nameplate no matter whether V/F control or vector control is adopted.

To achieve better V/F or vector control performance, motor auto-tuning is required. The motor auto-tuning accuracy depends on the correct setting of motor nameplate parameters.

Function Code	Parameter Name	Setting Range	Default
F1-06	Stator resistance (asynchronous motor)	0.001–65.535 Ω (AC drive power ≤ 55 kW) 0.0001–6.5535 Ω (AC drive power > 55 kW)	Model dependent
F1-07	Rotor resistance (asynchronous motor)	0.001–65.535 Ω (AC drive power ≤ 55 kW) 0.0001–6.5535 Ω (AC drive power > 55 kW)	Model dependent
F1-08	Leakage inductive reactance (asynchronous motor)	0.01–655.35 mH (AC drive power ≤ 55 kW) 0.001–65.535 mH (AC drive power > 55 kW)	Model dependent

Function Code	Parameter Name	Setting Range	Default
F1-09	Mutual inductive reactance (asynchronous motor)	0.1–6553.5 mH (AC drive power ≤ 55 kW) 0.01–655.35 mH (AC drive power > 55 kW)	Model dependent
F1-10	No-load current (asynchronous motor)	0.01 to F1-03 (AC drive power ≤ 55 kW) 0.1 to F1-03 (AC drive power > 55 kW)	Model dependent

The parameters in F1-06 to F1-10 are asynchronous motor parameters. These parameters are unavailable on the motor nameplate and are obtained by means of motor auto-tuning. Only F1-06 to F1-08 can be obtained through static motor auto-tuning. Through complete motor auto-tuning, encoder phase sequence and current loop PI can be obtained besides the parameters in F1-06 to F1-10.

Each time "Rated motor power" (F1-01) or "Rated motor voltage" (F1-02) is changed, the AC drive automatically restores values of F1-06 to F1-10 to the parameter setting for the common standard Y series asynchronous motor.

If it is impossible to perform motor auto-tuning onsite, manually input the values of these parameters according to data provided by the motor manufacturer.

Function Code	Parameter Name	Setting Range	Default
F1-16	Stator resistance (synchronous motor)	0.001–65.535 Ω (AC drive power ≤ 55 kW) 0.0001–6.5535 Ω (AC drive power > 55 kW)	Model dependent
F1-17	Shaft D inductance (synchronous motor)	0.01–655.35 mH (AC drive power ≤ 55 kW) 0.001–65.535 mH (AC drive power > 55 kW)	Model dependent
F1-18	Shaft Q inductance (synchronous motor)	0.01–655.35 mH (AC drive power ≤ 55 kW) 0.001–65.535 mH (AC drive power > 55 kW)	Model dependent
F1-20	Back EMF (synchronous motor)	0.1–6553.5 V	Model dependent

F1-16 to F1-20 are synchronous motor parameters. These parameters are unavailable on the nameplate of most synchronous motors and can be obtained by means of "Synchronous motor no-load auto-tuning". Through "Synchronous motor with-load auto-tuning", only the encoder phase sequence and installation angle can be obtained.

Each time "Rated motor power" (F1-01) or "Rated motor voltage" (F1-02) is changed, the AC drive automatically modifies the values of F1-16 to F1-20.

You can also directly set the parameters based on the data provided by the synchronous motor manufacturer.

Function Code	Parameter Name	Setting Range	Default
F1-27	Encoder pulses per revolution	1–65535	1024

This parameter is used to set the pulses per revolution (PPR) of ABZ or UVW incremental encoder. In CLVC mode, the motor cannot run properly if this parameter is set incorrectly.

Function Code	Parameter Name	Setting Range	Default
F1-28	Encoder type	0: ABZ incremental encoder 1: UVW incremental encoder 2: Resolver 3: SIN/COS encoder 4: Wire-saving UVW encoder	0

The MD380 supports multiple types of encoder. Different PG cards are required for different types of encoder. Select the appropriate PG card for the encoder used. Any of the five encoder types is applicable to synchronous motor. Only ABZ incremental encoder and resolver are applicable to asynchronous motor.

After installation of the PG card is complete, set this parameter properly based on the actual condition. Otherwise, the AC drive cannot run properly.

Function Code	Parameter Name	Setting Range	Default
F1-30	A/B phase sequence of ABZ incremental encoder	0: Forward 1: Reserve	0

This parameter is valid only for ABZ incremental encoder (F1-28 = 0) and is used to set the A/B phase sequence of the ABZ incremental encoder.

It is valid for both asynchronous motor and synchronous motor. The A/B phase sequence can be obtained through "Asynchronous motor complete auto-tuning" or "Synchronous motor no-load auto-tuning".

Function Code	Parameter Name	Setting Range	Default
F1-31	Encoder installation angle	0.0°–359.9°	0.0°

This parameter is applicable only to synchronous motor. It is valid for ABZ incremental encoder, UVW incremental encoder, resolver and wire-saving UVW encoder, but invalid for SIN/COS encoder.

It can be obtained through synchronous motor no-load auto-tuning or with-load auto-tuning. After installation of the synchronous motor is complete, the value of this parameter must be obtained by motor auto-tuning. Otherwise, the motor cannot run properly.

Function Code	Parameter Name	Setting Range	Default
F1-32	U, V, W phase sequence of UVW encoder	0: Forward 1: Reverse	0
F1-33	UVW encoder angle offset	0.0°–359.9°	0.0°

These two parameters are valid only when the UVW encoder is applied to a synchronous motor. They can be obtained by synchronous motor no-load auto-tuning or with-load auto-tuning. After installation of the synchronous motor is complete, the values of these two parameters must be obtained by motor auto-tuning. Otherwise, the motor cannot run properly.

Function Code	Parameter Name	Setting Range	Default
F1-34	Number of pole pairs of resolver	1-65535	1

If a resolver is applied, set the number of pole pairs properly.

Function Code	Parameter Name	Setting Range	Default
F1-36	Encoder wire-break fault detection time	0.0s: No action 0.1-10.0s	0.0s

This parameter is used to set the time that a wire-break fault lasts. If it is set to 0.0s, the AC drive does not detect the encoder wire-break fault. If the duration of the encoder wire-break fault detected by the AC drive exceeds the time set in this parameter, the AC drive reports Err20.

Function Code	Parameter Name	Setting Range	Default
F1-37	Auto-tuning selection	0: No auto-tuning 1: Asynchronous motor static auto-tuning 2: Asynchronous motor complete auto-tuning 11: Synchronous motor with-load auto-tuning 12: Synchronous motor no-load auto-tuning	0

- 0: No auto-tuning

Auto-tuning is prohibited.

- 1: Asynchronous motor static auto-tuning

It is applicable to scenarios where complete auto-tuning cannot be performed because the asynchronous motor cannot be disconnected from the load.

Before performing static auto-tuning, properly set the motor type and motor nameplate parameters of F1-00 to F1-05 first. The AC drive will obtain parameters of F1-06 to F1-08 by static auto-tuning.

Set this parameter to 1, and press . Then, the AC drive starts static auto-tuning.

- 2: Asynchronous motor complete auto-tuning

To perform this type of auto-tuning, ensure that the motor is disconnected from the load. During the process of complete auto-tuning, the AC drive performs static auto-tuning first and then accelerates to 80% of the rated motor frequency within the acceleration time set in F0-17. The AC drive keeps running for a certain period and then decelerates to stop within deceleration time set in F0-18.

Before performing complete auto-tuning, properly set the motor type, motor nameplate parameters of F1-00 to F1-05, "Encoder type" (F1-28) and "Encoder pulses per revolution" (F1-27) first.

The AC drive will obtain motor parameters of F1-06 to F1-10, "A/B phase sequence of ABZ incremental encoder" (F1-30) and vector control current loop PI parameters of F2-13 to F2-16 by complete auto-tuning.

Set this parameter to 2, and press . Then, the AC drive starts complete auto-tuning.

- 11: Synchronous motor with-load auto-tuning

It is applicable to scenarios where the synchronous motor cannot be disconnected from the load. During with-load auto-tuning, the motor rotates at the speed of 10 PRM.

Before performing with-load auto-tuning, properly set the motor type and motor nameplate parameters of F1-00 to F1-05 first.

By with-load auto-tuning, the AC drive obtains the initial position angle of the synchronous motor, which is a necessary prerequisite of the motor's normal running. Before the first use of the synchronous motor after installation, motor auto-tuning must be performed.

Set this parameter to 11, and press . Then, the AC drive starts with-load auto-tuning.

- 12: Synchronous motor no-load auto-tuning

If the synchronous motor can be disconnected from the load, no-load auto-tuning is recommended, which will achieve better running performance compared with with-load auto-tuning.

During the process of no-load auto-tuning, the AC drive performs with-load auto-tuning first and then accelerates to 80% of the rated motor frequency within the acceleration time set in F0-17. The AC drive keeps running for a certain period and then decelerates to stop within the deceleration time set in F0-18.

Before performing no-load auto-tuning, properly set the motor type, motor nameplate parameters of F1-00 to F1-05, "Encoder type" (F1-28) and "Encoder pulses per revolution" (F1-27) and "Number of pole pairs of resolver" (F1-34) first.

The AC drive will obtain motor parameters of F1-16 to F1-20, encoder related parameters of F1-30 to F1-33 and vector control current loop PI parameters of F2-13 to F2-16 by no-load auto-tuning.

Set this parameter to 12, and press . Then, the AC drive starts no-load auto-tuning.

Note

Motor auto-tuning can be performed only in operation panel mode.

Group F2: Vector Control Parameters

Group F2 is valid for vector control, and invalid for V/F control.

Function Code	Parameter Name	Setting Range	Default
F2-00	Speed loop proportional gain 1	0-100	30
F2-01	Speed loop integral time 1	0.01-10.00s	0.50s
F2-02	Switchover frequency 1	0.00 to F2-05	5.00 Hz
F2-03	Speed loop proportional gain 2	0-100	20

Function Code	Parameter Name	Setting Range	Default
F2-04	Speed loop integral time 2	0.01–10.00s	1.00s
F2-05	Switchover frequency 2	F2-02 to maximum output frequency	10.00 Hz

Speed loop PI parameters vary with running frequencies of the AC drive.

- If the running frequency is less than or equal to "Switchover frequency 1" (F2-02), the speed loop PI parameters are F2-00 and F2-01.
- If the running frequency is equal to or greater than "Switchover frequency 2" (F2-05), the speed loop PI parameters are F2-03 and F2-04.
- If the running frequency is between F2-02 and F2-05, the speed loop PI parameters are obtained from the linear switchover between the two groups of PI parameters, as shown in Figure 6-3.

Figure 6-3 Relationship between running frequencies and PI parameters

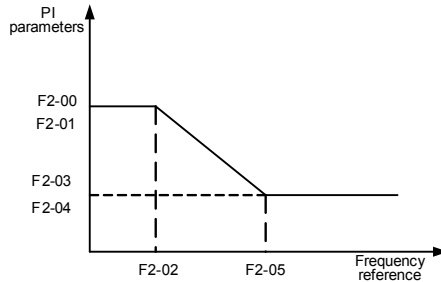

The speed dynamic response characteristics in vector control can be adjusted by setting the proportional gain and integral time of the speed regulator.

To achieve a faster system response, increase the proportional gain and reduce the integral time. Be aware that this may lead to system oscillation.

The recommended adjustment method is as follows:

If the factory setting cannot meet the requirements, make proper adjustment. Increase the proportional gain first to ensure that the system does not oscillate, and then reduce the integral time to ensure that the system has quick response and small overshoot.

Note

Improper PI parameter setting may cause too large speed overshoot, and overvoltage fault may even occur when the overshoot drops.

Function Code	Parameter Name	Setting Range	Default
F2-06	Vector control slip gain	50%–200%	100%

For SFVC, it is used to adjust speed stability accuracy of the motor. When the motor with load runs at a very low speed, increase the value of this parameter; when the motor with load runs at a very large speed, decrease the value of this parameter.

For CLVC, it is used to adjust the output current of the AC drive with same load.

Function Code	Parameter Name	Setting Range	Default
F2-07	Time constant of speed loop filter	0.000–0.100s	0.000s

In the vector control mode, the output of the speed loop regulator is torque current reference. This parameter is used to filter the torque references. It need not be adjusted generally and can be increased in the case of large speed fluctuation. In the case of motor oscillation, decrease the value of this parameter properly.

If the value of this parameter is small, the output torque of the AC drive may fluctuate greatly, but the response is quick.

Function Code	Parameter Name	Setting Range	Default
F2-08	Vector control over-excitation gain	0–200	64

During deceleration of the AC drive, over-excitation control can restrain rise of the bus voltage to avoid the overvoltage fault. The larger the over-excitation gain is, the better the restraining effect is.

Increase the over-excitation gain if the AC drive is liable to overvoltage error during deceleration. Too large over-excitation gain, however, may lead to an increase in output current. Therefore, set this parameter to a proper value in actual applications.

Set the over-excitation gain to 0 in applications of small inertia (the bus voltage will not rise during deceleration) or where there is a braking resistor.

Function Code	Parameter Name	Setting Range	Default
F2-09	Torque upper limit source in speed control mode	0: F2-10 1: AI1 2: AI2 3: AI3 4: Pulse setting (DI5) 5: Communication setting	0
F2-10	Digital setting of torque upper limit in speed control mode	0.0%–200.0%	150.0%

In the speed control mode, the maximum output torque of the AC drive is restricted by F2-09. If the torque upper limit is analog, pulse or communication setting, 100% of the setting corresponds to the value of F2-10, and 100% of the value of F2-10 corresponds to the AC drive rated torque.

For details on the AI1, AI2 and AI3 setting, see the description of the AI curves in group F4.

For details on the pulse setting, see the description of F4-28 to F4-32.

When the AC drive is in communication with the master, if F2-09 is set to 5 “communication setting”, F2-10 “Digital setting of torque upper limit in speed control mode” can be set via communication from the master.

In other conditions, the host computer writes data -100.00% to 100.00% by the communication address 0x1000, where 100.0% corresponds to the value of F2-10. The communication protocol can be Modbus, CANopen, CANlink or PROFIBUS-DP.

Function Code	Parameter Name	Setting Range	Default
F2-13	Excitation adjustment proportional gain	0–20000	2000
F2-14	Excitation adjustment integral gain	0–20000	1300
F2-15	Torque adjustment proportional gain	0–20000	2000
F2-16	Torque adjustment integral gain	0–20000	1300

These are current loop PI parameters for vector control. These parameters are automatically obtained through "Asynchronous motor complete auto-tuning" or "Synchronous motor no-load auto-tuning", and need not be modified.

The dimension of the current loop integral regulator is integral gain rather than integral time.

Note that too large current loop PI gain may lead to oscillation of the entire control loop. Therefore, when current oscillation or torque fluctuation is great, manually decrease the proportional gain or integral gain here.

Function Code	Parameter Name	Setting Range	Default
F2-18	Field weakening mode of synchronous motor	0: No field weakening 1: Direct calculation 2: Automatic adjustment	1
F2-19	Field weakening depth of synchronous motor	50%–500%	100%
F2-20	Maximum field weakening current	1%–300%	50%
F2-21	Field weakening automatic adjustment gain	10%–500%	100%
F2-22	Field weakening integral multiple	2–10	2

These parameters are used to set field weakening control for the synchronous motor.

If F2-18 is set to 0, field weakening control on the synchronous motor is disabled. In this case, the maximum rotational speed is related to the AC drive bus voltage. If the motor's maximum rotational speed cannot meet the requirements, enable the field weakening function to increase the speed.

The MD380 provides two field weakening modes: direct calculation and automatic adjustment.

- In direct calculation mode, directly calculate the demagnetized current and manually adjust the demagnetized current by means of F2-19. The smaller the demagnetized current is, the smaller the total output current is. However, the desired field weakening effect may not be achieved.
- In automatic adjustment mode, the best demagnetized current is selected automatically. This may influence the system dynamic performance or cause instability.

The adjustment speed of the field weakening current can be changed by modifying the values of F2-21 and F2-22. A very quick adjustment may cause instability. Therefore, generally do not modify them manually.

Group F3: V/F Control Parameters

Group F3 is valid only for V/F control.

The V/F control mode is applicable to low load applications (fan or pump) or applications where one AC drive operates multiple motors or there is a large difference between the AC drive power and the motor power.

Function Code	Parameter Name	Setting Range	Default
F3-00	V/F curve setting	0: Linear V/F 1: Multi-point V/F 2: Square V/F 3: 1.2-power V/F 4: 1.4-power V/F 6: 1.6-power V/F 8: 1.8-power V/F 9: Reserved 10: V/F complete separation 11: V/F half separation	0

- 0: Linear V/F

It is applicable to common constant torque load.

- 1: Multi-point V/F

It is applicable to special load such as dehydrator and centrifuge. Any such V/F curve can be obtained by setting parameters of F3-03 to F3-08.

- 2: Square V/F

It is applicable to centrifugal loads such as fan and pump.

- 3 to 8: V/F curve between linear V/F and square V/F
- 10: V/F complete separation

In this mode, the output frequency and output voltage of the AC drive are independent. The output frequency is determined by the frequency source, and the output voltage is determined by "Voltage source for V/F separation" (F3-13).

It is applicable to induction heating, inverse power supply and torque motor control.

- 11: V/F half separation

In this mode, V and F are proportional and the proportional relationship can be set in F3-13. The relationship between V and F are also related to the rated motor voltage and rated motor frequency in Group F1.

Assume that the voltage source input is X (0 to 100%), the relationship between V and F is:

$$V/F = 2 \times X \times (\text{Rated motor voltage})/(\text{Rated motor frequency})$$

Function Code	Parameter Name	Setting Range	Default
F3-01	Torque boost	0.0%–30%	Model dependent
F3-02	Cut-off frequency of torque boost	0.00 Hz to maximum output frequency	50.00 Hz

To compensate the low frequency torque characteristics of V/F control, you can boost the output voltage of the AC drive at low frequency by modifying F3-01.

If the torque boost is set to too large, the motor may overheat, and the AC drive may suffer overcurrent.

If the load is large and the motor startup torque is insufficient, increase the value of F3-01. If the load is small, decrease the value of F3-01. If it is set to 0.0, the AC drive performs automatic torque boost. In this case, the AC drive automatically calculates the torque boost value based on motor parameters including the stator resistance.

F3-02 specifies the frequency under which torque boost is valid. Torque boost becomes invalid when this frequency is exceeded, as shown in the following figure.

Figure 6-4 Manual torque boost

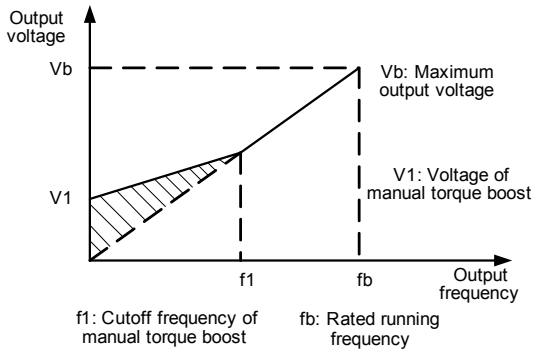

Function Code	Parameter Name	Setting Range	Default
F3-03	Multi-point V/F frequency 1 (F1)	0.00 Hz to F3-05	0.00 Hz
F3-04	Multi-point V/F voltage 1 (V1)	0.0%–100.0%	0.0%
F3-05	Multi-point V/F frequency 2 (F2)	F3-03 to F3-07	0.00 Hz
F3-06	Multi-point V/F voltage 2 (V2)	0.0%–100.0%	0.0%
F3-07	Multi-point V/F frequency 3 (F3)	F3-05 to rated motor frequency (F1-04) Note: The rated frequencies of motors 2, 3, and 4 are respectively set in A2-04, A3-04, and A4-04.	0.00 Hz
F3-08	Multi-point V/F voltage 3 (V3)	0.0%–100.0%	0.0%

These six parameters are used to define the multi-point V/F curve.

The multi-point V/F curve is set based on the motor's load characteristic. The relationship between voltages and frequencies is:

$$V1 < V2 < V3, F1 < F2 < F3$$

At low frequency, higher voltage may cause overheat or even burnt out of the motor and overcurrent stall or overcurrent protection of the AC drive.

Figure 6-5 Setting of multi-point V/F curve

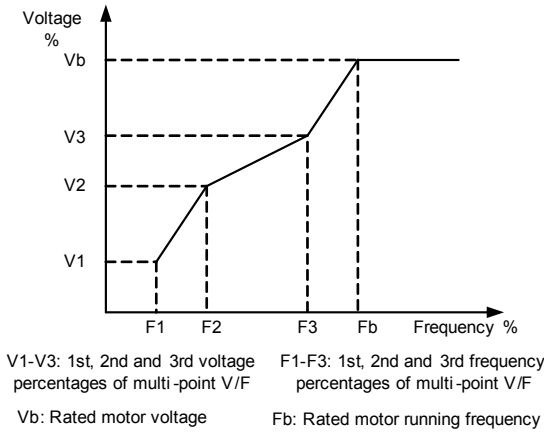

Function Code	Parameter Name	Setting Range	Default
F3-09	V/F slip compensation gain	0%–200.0%	0.0%

This parameter is valid only for the asynchronous motor.

It can compensate the rotational speed slip of the asynchronous motor when the load of the motor increases, stabilizing the motor speed in case of load change. If this parameter is set to 100%, it indicates that the compensation when the motor bears rated load is the rated motor slip. The rated motor slip is automatically obtained by the AC drive through calculation based on the rated motor frequency and rated motor rotational speed in group F1.

Generally, if the motor rotational speed is different from the target speed, slightly adjust this parameter.

Function Code	Parameter Name	Setting Range	Default
F3-10	V/F over-excitation gain	0–200	64

During deceleration of the AC drive, over-excitation can restrain rise of the bus voltage, preventing the overvoltage fault. The larger the over-excitation is, the better the restraining result is.

Increase the over-excitation gain if the AC drive is liable to overvoltage error during deceleration. However, too large over-excitation gain may lead to an increase in the output current. Set F3-09 to a proper value in actual applications.

Set the over-excitation gain to 0 in the applications where the inertia is small and the bus voltage will not rise during motor deceleration or where there is a braking resistor.

Function Code	Parameter Name	Setting Range	Default
F3-11	V/F oscillation suppression gain	0-100	Model dependent

Set this parameter to a value as small as possible in the prerequisite of efficient oscillation suppression to avoid influence on V/F control.

Set this parameter to 0 if the motor has no oscillation. Increase the value properly only when the motor has obvious oscillation. The larger the value is, the better the oscillation suppression result will be.

When the oscillation suppression function is enabled, the rated motor current and no-load current must be correct. Otherwise, the V/F oscillation suppression effect will not be satisfactory.

Function Code	Parameter Name	Setting Range	Default
F3-13	Voltage source for V/F separation	0: Digital setting (F3-14) 1: AI1 2: AI2 3: AI3 4: Pulse setting (DI5) 5: Multi-reference 6: Simple PLC 7: PID 8: Communication setting 100.0% corresponds to the rated motor voltage (F1-02, A4-02, A5-02, A6-02).	0
F3-14	Voltage digital setting for V/F separation	0 V to rated motor voltage	0 V

V/F separation is generally applicable to scenarios such as induction heating, inverse power supply and motor torque control.

If V/F separated control is enabled, the output voltage can be set in F3-14 or by means of analog, multi-reference, simple PLC, PID or communication. If you set the output voltage by means of non-digital setting, 100% of the setting corresponds to the rated motor voltage. If a negative percentage is set, its absolute value is used as the effective value.

- 0: Digital setting (F3-14)
The output voltage is set directly in F3-14.
- 1: AI1; 2: AI2; 3: AI3
The output voltage is set by AI terminals.
- 4: Pulse setting (DI5)
The output voltage is set by pulses of the terminal DI5.

Pulse setting specification: voltage range 9–30 V, frequency range 0–100 kHz

- 5: Multi-reference

If the voltage source is multi-reference, parameters in group F4 and FC must be set to determine the corresponding relationship between setting signal and setting voltage. 100.0% of the multi-reference setting in group FC corresponds to the rated motor voltage.

- 6: Simple PLC

If the voltage source is simple PLC mode, parameters in group FC must be set to determine the setting output voltage.

- 7: PID

The output voltage is generated based on PID closed loop. For details, see the description of PID in group FA.

- 8: Communication setting

The output voltage is set by the host computer by means of communication.

The voltage source for V/F separation is set in the same way as the frequency source. For details, see F0-03. 100.0% of the setting in each mode corresponds to the rated motor voltage. If the corresponding value is negative, its absolute value is used.

Function Code	Parameter Name	Setting Range	Default
F3-15	Voltage rise time of V/F separation	0.0–1000.0s	0.0s
F3-16	Voltage decline time of V/F separation	0.0–1000.0s	0.0s

F3-15 indicates the time required for the output voltage to rise from 0 V to the rated motor voltage shown as t_1 in the following figure.

F3-16 indicates the time required for the output voltage to decline from the rated motor voltage to 0 V, shown as t_2 in the following figure.

Figure 6-6 Voltage of V/F separation

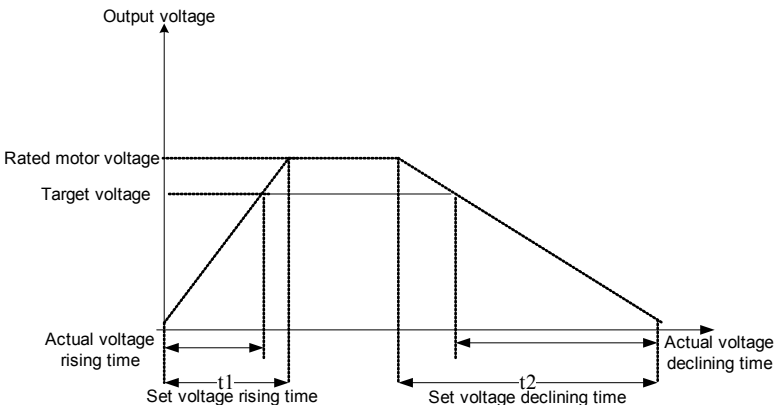

Group F4: Input Terminals

The MD380 provides five DI terminals (DI5 can be used for high-speed pulse input) and two analog input (AI) terminals. The optional extension card provides another five DI terminals (DI6 to DI10) and an AI terminal (AI3).

Function Code	Parameter Name	Default	Remark
F4-00	DI1 function selection	1: Forward RUN (FWD)	Standard
F4-01	DI2 function selection	4: Forward JOG (FJOG)	Standard
F4-02	DI3 function selection	9: Fault reset (RESET)	Standard
F4-03	DI4 function selection	12: Multi-reference terminal 1	Standard
F4-04	DI5 function selection	13: Multi-reference terminal 2	Standard
F4-05	DI6 function selection	0	Extended
F4-06	DI7 function selection	0	Extended
F4-07	DI8 function selection	0	Extended
F4-08	DI9 function selection	0	Extended
F4-09	DI10 function selection	0	Extended

The following table lists the functions available for the DI terminals.

Table 6-1 Functions of DI terminals

Value	Function	Description
0	No function	Set 0 for reserved terminals to avoid malfunction.
1	Forward RUN (FWD)	The terminal is used to control forward or reverse RUN of the AC drive.
2	Reverse RUN (REV)	
3	Three-line control	The terminal determines three-line control of the AC drive. For details, see the description of F4-11.
4	Forward JOG (FJOG)	FJOG indicates forward JOG running, while RJOG indicates reverse JOG running. The JOG frequency, acceleration time and deceleration time are described respectively in F8-00, F8-01 and F8-02.
5	Reverse JOG (RJOG)	
6	Terminal UP	If the frequency is determined by external terminals, the terminals with the two functions are used as increment and decrement commands for frequency modification. When the frequency source is digital setting, they are used to adjust the frequency.
7	Terminal DOWN	
8	Coast to stop	The AC drive blocks its output, the motor coasts to rest and is not controlled by the AC drive. It is the same as coast to stop described in F6-10.
9	Fault reset (RESET)	The terminal is used for fault reset function, the same as the function of RESET key on the operation panel. Remote fault reset is implemented by this function.

Value	Function	Description
10	RUN pause	The AC drive decelerates to stop, but the running parameters are all memorized, such as PLC, swing frequency and PID parameters. After this function is disabled, the AC drive resumes its status before stop.
11	Normally open (NO) input of external fault	If this terminal becomes ON, the AC drive reports Err15 and performs the fault protection action. For more details, see the description of F9-47.
12	Multi-reference terminal 1	The setting of 16 speeds or 16 other references can be implemented through combinations of 16 states of these four terminals.
13	Multi-reference terminal 2	
14	Multi-reference terminal 3	
15	Multi-reference terminal 4	
16	Terminal 1 for acceleration/ deceleration time selection	Totally four groups of acceleration/deceleration time can be selected through combinations of two states of these two terminals.
17	Terminal 2 for acceleration/ deceleration time selection	
18	Frequency source switchover	The terminal is used to perform switchover between two frequency sources according to the setting in F0-07.
19	UP and DOWN setting clear (terminal, operation panel)	If the frequency source is digital setting, the terminal is used to clear the modification by using the UP/ DOWN function or the increment/decrement key on the operation panel, returning the set frequency to the value of F0-08.
20	Command source switchover terminal	If the command source is set to terminal control (F0-02 = 1), this terminal is used to perform switchover between terminal control and operation panel control. If the command source is set to communication control (F0-02 = 2), this terminal is used to perform switchover between communication control and operation panel control.
21	Acceleration/Deceleration prohibited	It enables the AC drive to maintain the current frequency output without being affected by external signals (except the STOP command).
22	PID pause	PID is invalid temporarily. The AC drive maintains the current frequency output without supporting PID adjustment of frequency source.
23	PLC status reset	The terminal is used to restore the original status of PLC control for the AC drive when PLC control is started again after a pause.
24	Swing pause	The AC drive outputs the central frequency, and the swing frequency function pauses.
25	Counter input	This terminal is used to count pulses.
26	Counter reset	This terminal is used to clear the counter status.
27	Length count input	This terminal is used to count the length.
28	Length reset	This terminal is used to clear the length.

Value	Function	Description
29	Torque control prohibited	The AC drive is prohibited from torque control and enters the speed control mode.
30	Pulse input (enabled only for DI5)	DI5 is used for pulse input.
31	Reserved	Reserved.
32	Immediate DC braking	After this terminal becomes ON, the AC drive directly switches over to the DC braking state.
33	Normally closed (NC) input of external fault	After this terminal becomes ON, the AC drive reports Err15 and stops.
34	Frequency modification forbidden	After this terminal becomes ON, the AC drive does not respond to any frequency modification.
35	Reverse PID action direction	After this terminal becomes ON, the PID action direction is reversed to the direction set in FA-03.
36	External STOP terminal 1	In operation panel mode, this terminal can be used to stop the AC drive, equivalent to the function of the STOP key on the operation panel.
37	Command source switchover terminal 2	It is used to perform switchover between terminal control and communication control. If the command source is terminal control, the system will switch over to communication control after this terminal becomes ON.
38	PID integral pause	After this terminal becomes ON, the integral adjustment function pauses. However, the proportional and differentiation adjustment functions are still valid.
39	Switchover between main frequency source X and preset frequency	After this terminal becomes ON, the frequency source X is replaced by the preset frequency set in F0-08.
40	Switchover between auxiliary frequency source Y and preset frequency	After this terminal is enabled, the frequency source Y is replaced by the preset frequency set in F0-08.
41	Motor selection terminal 1	Switchover among the four groups of motor parameters can be implemented through the four state combinations of these two terminals.
42	Motor selection terminal 2	
43	PID parameter switchover	If the PID parameters switchover performed by means of DI terminal (FA-18 = 1), the PID parameters are FA-05 to FA-07 when the terminal becomes OFF; the PID parameters are FA-15 to FA-17 when this terminal becomes ON.
44	User-defined fault 1	If these two terminals become ON, the AC drive reports Err27 and Err28 respectively, and performs fault protection actions based on the setting in F9-49.
45	User-defined fault 2	
46	Speed control/Torque control switchover	This terminal enables the AC drive to switch over between speed control and torque control. When this terminal becomes OFF, the AC drive runs in the mode set in A0-00. When this terminal becomes ON, the AC drive switches over to the other control mode.

Value	Function	Description
47	Emergency stop	When this terminal becomes ON, the AC drive stops within the shortest time. During the stop process, the current remains at the set current upper limit. This function is used to satisfy the requirement of stopping the AC drive in emergency state.
48	External STOP terminal 2	In any control mode (operation panel, terminal or communication), it can be used to make the AC drive decelerate to stop. In this case, the deceleration time is deceleration time 4.
49	Deceleration DC braking	When this terminal becomes ON, the AC drive decelerates to the initial frequency of stop DC braking and then switches over to DC braking state.
50	Clear the current running time	When this terminal becomes ON, the AC drive's current running time is cleared. This function must be supported by F8-42 and F8-53.
51	Switchover between two-line mode and three-line mode	It is used to perform switchover between two-line control and three-line control. If F4 -11 is set to Two-line mode 1, the system switches over to three-line mode 1 when the DI allocated with this function becomes ON

The four multi-reference terminals have 16 state combinations, corresponding to 16 reference values, as listed in the following table.

Table 6-2 State combinations of the four multi-reference terminals

K4	K3	K2	K1	Reference Setting	Corresponding Parameter
OFF	OFF	OFF	OFF	Reference 0	FC-00
OFF	OFF	OFF	ON	Reference 1	FC-01
OFF	OFF	ON	OFF	Reference 2	FC-02
OFF	OFF	ON	ON	Reference 3	FC-03
OFF	ON	OFF	OFF	Reference 4	FC-04
OFF	ON	OFF	ON	Reference 5	FC-05
OFF	ON	ON	OFF	Reference 6	FC-06
OFF	ON	ON	ON	Reference 7	FC-07
ON	OFF	OFF	OFF	Reference 8	FC-08
ON	OFF	OFF	ON	Reference 9	FC-09
ON	OFF	ON	OFF	Reference 10	FC-10
ON	OFF	ON	ON	Reference 11	FC-11
ON	ON	OFF	OFF	Reference 12	FC-12
ON	ON	OFF	ON	Reference 13	FC-13
ON	ON	ON	OFF	Reference 14	FC-14
ON	ON	ON	ON	Reference 15	FC-15

If the frequency source is multi-reference, the value 100% of FC-00 to FC-15 corresponds to the value of F0-10 (Maximum frequency).

Besides the multi-speed function, the multi-reference can be also used as the PID setting source or the voltage source for V/F separation, satisfying the requirement on switchover of different setting values.

Two terminals for acceleration/deceleration time selection have four state combinations, as listed in the following table.

Table 6-3 State combinations of two terminals for acceleration/deceleration time selection

Terminal 2	Terminal 1	Acceleration/Deceleration Time Selection	Corresponding Parameters
OFF	OFF	Acceleration/Deceleration time 1	F0-17, F0-18
OFF	ON	Acceleration/Deceleration time 2	F8-03, F8-04
ON	OFF	Acceleration/Deceleration time 3	F8-05, F8-06
ON	ON	Acceleration/Deceleration time 4	F8-07, F8-08

Two motor selection terminals have four state combinations, corresponding to four motors, as listed in the following table.

Table 6-4 State combinations of two motor selection terminals

Terminal 2	Terminal 1	Selected Motor	Corresponding Parameters
OFF	OFF	Motor 1	Group F1, Group F2
OFF	ON	Motor 2	Group A2
ON	OFF	Motor 3	Group A3
ON	ON	Motor 4	Group A4

Function Code	Parameter Name	Setting Range	Default
F4-10	DI filter time	0.000–1.000s	0.010s

It is used to set the software filter time of DI terminal status. If DI terminals are liable to interference and may cause malfunction, increase the value of this parameter to enhance the anti-interference capability. However, increase of DI filter time will reduce the response of DI terminals.

Function Code	Parameter Name	Setting Range	Default
F4-11	Terminal command mode	0: Two-line mode 1 1: Two-line mode 2 2: Three-line mode 1 3: Three-line mode 2	0

This parameter is used to set the mode in which the AC drive is controlled by external terminals. The following uses DI1, DI2 and DI3 among DI1 to DI10 as an example, with allocating functions of DI1, DI2 and DI3 by setting F4-00 to F4-02.

- 0: Two-line mode 1

It is the most commonly used two-line mode, in which the forward/reverse rotation of the motor is decided by DI1 and DI2. The parameters are set as below:

Function Code	Parameter Name	Value	Function Description
F4-11	Terminal command mode	0	Two-line 1
F4-00	DI1 function selection	1	Forward RUN (FWD)
F4-01	DI2 function selection	2	Reverse RUN (REV)

Figure 6-7 Setting of two-line mode 1

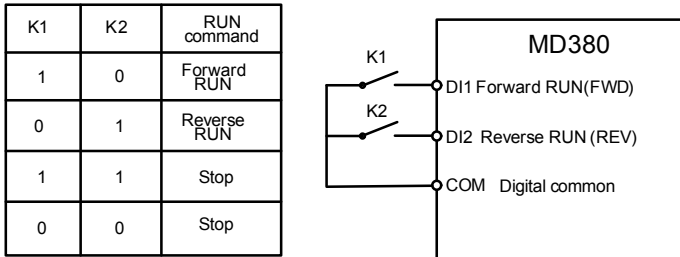

As shown in the preceding figure, when only K1 is ON, the AC drive instructs forward rotation. When only K2 is ON, the AC drive instructs reverse rotation. When K1 and K2 are ON or OFF simultaneously, the AC drive stops.

- 1: Two-line mode 2

In this mode, DI1 is RUN enabled terminal, and DI2 determines the running direction. The parameters are set as below:

Function Code	Parameter Name	Value	Function Description
F4-11	Terminal command mode	1	Two-line 2
F4-00	DI1 function selection	1	RUN enabled
F4-01	DI2 function selection	2	Forward or reverse direction

Figure 6-8 Setting of two-line mode 2

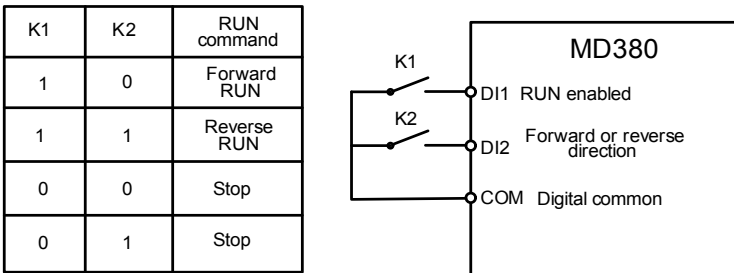

As shown in the preceding figure, if K1 is ON, the AC drive instructs forward rotation when K2 is OFF, and instructs reverse rotation when K2 is ON. If K1 is OFF, the AC drive stops.

- 2: Three-line mode 1

In this mode, DI3 is RUN enabled terminal, and the direction is decided by DI1 and DI2. The parameters are set as below:

Function Code	Parameter Name	Value	Function Description
F4-11	Terminal command mode	2	Three-line 1
F4-00	DI1 function selection	1	Forward RUN (FWD)
F4-01	DI2 function selection	2	Reverse RUN (REV)
F4-02	DI3 function selection	3	Three-line control

Figure 6-9 Setting of three-line mode 1

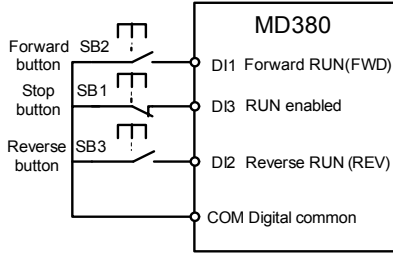

As shown in the preceding figure, if SB1 is ON, the AC drive instructs forward rotation when SB2 is pressed to be ON and instructs reverse rotation when SB3 is pressed to be ON. The AC drive stops immediately after SB1 becomes OFF. During normal startup and running, SB1 must remain ON. The AC drive's running state is determined by the final actions on SB1, SB2 and SB3.

- 3: Three-line mode 2

In this mode, DI3 is RUN enabled terminal. The RUN command is given by DI1 and the direction is decided by DI2. The parameters are set as below:

Function Code	Parameter Name	Value	Function Description
F4-11	Terminal command mode	3	Three-line 2
F4-00	DI1 function selection	1	RUN enabled
F4-01	DI2 function selection	2	Forward or reverse direction
F4-02	DI3 function selection	3	Three-line control

Figure 6-10 Setting of three-line mode 2

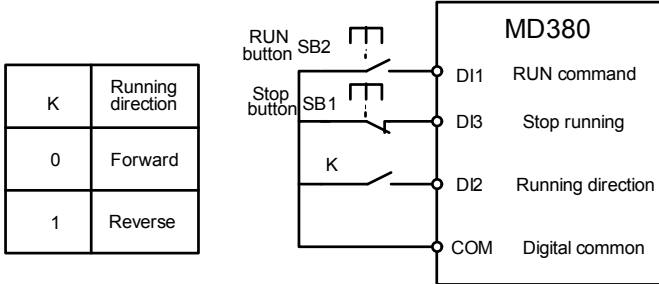

As shown in the preceding figure, if SB1 is ON, the AC drive starts running when SB2 is pressed to be ON; the AC drive instructs forward rotation when K is OFF and instructs reverse rotation when K is ON. The AC drive stops immediately after SB1 becomes OFF. During normal startup and running, SB1 must remain ON. The AC drive's running state is determined by the final actions of SB1, SB2 and K.

Function Code	Parameter Name	Setting Range	Default
F4-12	Terminal UP/DOWN rate	0.01–65.535 Hz/s	1.00 Hz/s

It is used to adjust the rate of change of frequency when the frequency is adjusted by means of terminal UP/DOWN.

- If F0-22 (Frequency reference resolution) is 2, the setting range is 0.001–65.535 Hz/s.
- If F0-22 (Frequency reference resolution) is 1, the setting range is 0.01–655.35 Hz/s.

Function Code	Parameter Name	Setting Range	Default
F4-13	AI curve 1 minimum input	0.00 V to F4-15	0.00 V
F4-14	Corresponding setting of AI curve 1 minimum input	-100.00%–100.0%	0.0%
F4-15	AI curve 1 maximum input	F4-13 to 10.00 V	10.00 V
F4-16	Corresponding setting of AI curve 1 maximum input	-100.00%–100.0%	100.0%
F4-17	AI1 filter time	0.00–10.00s	0.10s

These parameters are used to define the relationship between the analog input voltage and the corresponding setting. When the analog input voltage exceeds the maximum value (F4-15), the maximum value is used. When the analog input voltage is less than the minimum value (F4-13), the value set in F4-34 (Setting for AI less than minimum input) is used.

When the analog input is current input, 1 mA current corresponds to 0.5 V voltage.

F4-17 (AI1 filter time) is used to set the software filter time of AI1. If the analog input is liable to interference, increase the value of this parameter to stabilize the detected analog input. However, increase of the AI filter time will slow the response of analog detection. Set this parameter properly based on actual conditions.

In different applications, 100% of analog input corresponds to different nominal values. For details, refer to the description of different applications.

Two typical setting examples are shown in the following figure.

Figure 6-11 Corresponding relationship between analog input and set values

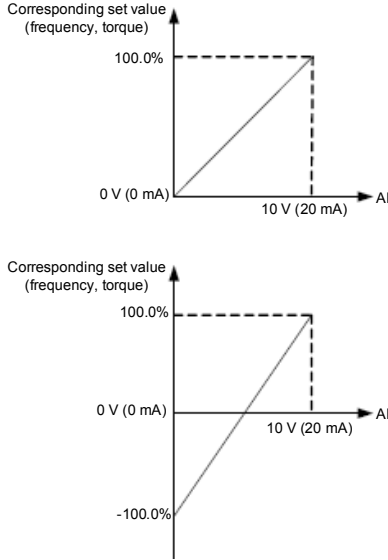

Function Code	Parameter Name	Setting Range	Default
F4-18	AI curve 2 minimum input	0.00 V to F4-20	0.00 V
F4-19	Corresponding setting of AI curve 2 minimum input	-100.00%~100.0%	0.0%
F4-20	AI curve 2 maximum input	F4-18 to 10.00 V	10.00 V
F4-21	Corresponding setting of AI curve 2 maximum input	-100.00%~100.0%	100.0%
F4-22	AI2 filter time	0.00~10.00s	0.10s

Function Code	Parameter Name	Setting Range	Default
F4-23	AI curve 3 minimum input	0.00 V to F4-25	0.00 V
F4-24	Corresponding setting of AI curve 3 minimum input	-100.00%~100.0%	0.0%
F4-25	AI curve 3 maximum input	F4-23 to 10.00 V	10.00 V
F4-26	Corresponding setting of AI curve 3 maximum input	-100.00%~100.0%	100.0%
F4-27	AI3 filter time	0.00~10.00s	0.10s

The method of setting AI2 and AI3 functions is similar to that of setting AI1 function.

Function Code	Parameter Name	Setting Range	Default
F4-28	Pulse minimum input	0.00 kHz to F4-30	0.00 kHz
F4-29	Corresponding setting of pulse minimum input	-100.00%–100.0%	0.0%
F4-30	Pulse maximum input	F4-28 to 50.00 kHz	50.00 kHz
F4-31	Corresponding setting of pulse maximum input	-100.00%–100.0%	100.0%
F4-32	Pulse filter time	0.00–10.00s	0.10s

These parameters are used to set the relationship between DI5 pulse input and corresponding settings. The pulses can only be input by DI5. The method of setting this function is similar to that of setting AI1 function.

Function Code	Parameter Name	Setting Range	Default
F4-33	AI curve selection	Unit's digit (AI1 curve selection)	321
		Curve 1 (2 points, see F4-13 to F4-16)	
		Curve 2 (2 points, see F4-18 to F4-21)	
		Curve 3 (2 points, see F4-23 to F4-26)	
		Curve 4 (4 points, see A6-00 to A6-07)	
		Curve 5 (4 points, see A6-08 to A6-15)	
		Ten's digit (AI2 curve selection)	
		Curve 1 to curve 5 (same as AI1)	
Hundred's digit (AI3 curve selection)	Curve 1 to curve 5 (same as AI1)		

The unit's digit, ten's digit and hundred's digit of this parameter are respectively used to select the corresponding curve of AI1, AI2 and AI3. Any of the five curves can be selected for AI1, AI2 and AI3.

Curve 1, curve 2 and curve 3 are all 2-point curves, set in group F4. Curve 4 and curve 5 are both 4-point curves, set in group A6.

The MD380 provides two AI terminals as standard. AI3 is provided by an optional extension card.

Function Code	Parameter Name	Setting Range	Default
F4-34	Setting for AI less than minimum input	Unit's digit (Setting for AI1 less than minimum input)	000
		0: Minimum value 1: 0.0%	
		Ten's digit (Setting for AI2 less than minimum input)	
		0, 1 (same as AI1)	
		Hundred's digit (Setting for AI3 less than minimum input)	
		0, 1 (same as AI1)	

This parameter is used to determine the corresponding setting when the analog input voltage is less than the minimum value. The unit's digit, ten's digit and hundred's digit of this parameter respectively correspond to the setting for AI2, AI2 and AI3.

If the value of a certain digit is 0, when analog input voltage is less than the minimum input, the corresponding setting of the minimum input (F4-14, F4-19, F4-24) is used.

If the value of a certain digit is 1, when analog input voltage is less than the minimum input, the corresponding value of this analog input is 0.0%.

Function Code	Parameter Name	Setting Range	Default
F4-35	DI1 delay time	0.0–3600.0s	0.0s
F4-36	DI2 delay time	0.0–3600.0s	0.0s
F4-37	DI3 delay time	0.0–3600.0s	0.0s

These parameters are used to set the delay time of the AC drive when the status of DI terminals changes.

Currently, only DI1, DI2 and DI3 support the delay time function.

Function Code	Parameter Name	Setting Range	Default
F4-38	DI valid mode selection 1	Unit's digit (DI1 valid mode)	00000
		0: High level valid 1: Low level valid	
		Ten's digit (DI2 valid mode)	
		0, 1 (same as DI1)	
		Hundred's digit (DI3 valid mode)	
		0, 1 (same as DI1)	
		Thousand's digit (DI4 valid mode)	
		0, 1 (same as DI1)	
		Ten thousand's digit (DI5 valid mode)	
0, 1 (same as DI1)			
F4-39	DI valid mode selection 2	Unit's digit (DI6 valid mode)	00000
		0, 1 (same as DI1)	
		Ten's digit (DI7 valid mode)	
		0, 1 (same as DI1)	
		Hundred's digit (DI8 state)	
		0, 1 (same as DI1)	
		Thousand's digit (DI9 valid mode)	
		0, 1 (same as DI1)	
		Ten thousand's digit (DI10 valid mode)	
0, 1 (same as DI1)			

These parameters are used to set the valid mode of DI terminals.

- 0: High level valid

The DI terminal is valid when being connected with COM, and invalid when being disconnected from COM.

- 1: Low level valid

The DI terminal is invalid when being connected with COM, and invalid when being disconnected from COM.

Function Code	Parameter Name	Setting Range	Default
F4-40	AI2 input signal selection	0: Voltage signal 1: Current signal	0

AI2 supports voltage/current output, which is determined by jumper. After setting the jumper, perform corresponding setting in F4-40.

Group F5: Output Terminals

The MD380 provides an analog output (AO) terminal, a digital output (DO) terminal, a relay terminal and a FM terminal (used for high-speed pulse output or open-collector switch signal output) as standard. If these output terminals cannot satisfy requirements, use an optional I/O extension card that provides an AO terminal (AO2), a relay terminal (relay 2) and a DO terminal (DO2).

Function Code	Parameter Name	Setting Range	Default
F5-00	FM terminal output mode	0: Pulse output (FMP) 1: Switch signal output (FMR)	0

The FM terminal is programmable multiplexing terminal. It can be used for high-speed pulse output (FMP), with maximum frequency of 50 kHz. Refer to F5-06 for relevant functions of FMP. It can also be used as open collector switch signal output (FMR).

Function Code	Parameter Name	Default
F5-01	FMR function (open-collector output terminal)	0
F5-02	Relay function (T/A-T/B-T/C)	2
F5-03	Extension card relay function (P/A-P/B-P/C)	0
F5-04	DO1 function selection (open-collector output terminal)	1
F5-05	Extension card DO2 function	4

These five parameters are used to select the functions of the five digital output terminals. T/A-T/B-T/C and P/A-P/B-P/C are respectively the relays on the control board and the extension card.

The functions of the output terminals are described in the following table.

Table 6-5 Functions of output terminals

Value	Function	Description
0	No output	The terminal has no function.
1	AC drive running	When the AC drive is running and has output frequency (can be zero), the terminal becomes ON.
2	Fault output (stop)	When the AC drive stops due to a fault, the terminal becomes ON.
3	Frequency-level detection FDT1 output	Refer to the descriptions of F8-19 and F8-20.
4	Frequency reached	Refer to the descriptions of F8-21.
5	Zero-speed running (no output at stop)	If the AC drive runs with the output frequency of 0, the terminal becomes ON. If the AC drive is in the stop state, the terminal becomes OFF.
6	Motor overload pre-warning	The AC drive judges whether the motor load exceeds the overload pre-warning threshold before performing the protection action. If the pre-warning threshold is exceeded, the terminal becomes ON. For motor overload parameters, see the descriptions of F9-00 to F9-02.
7	AC drive overload pre-warning	The terminal becomes ON 10s before the AC drive overload protection action is performed.
8	Set count value reached	The terminal becomes ON when the count value reaches the value set in FB-08.
9	Designated count value reached	The terminal becomes ON when the count value reaches the value set in FB-09.
10	Length reached	The terminal becomes ON when the detected actual length exceeds the value set in FB-05.
11	PLC cycle complete	When simple PLC completes one cycle, the terminal outputs a pulse signal with width of 250 ms.
12	Accumulative running time reached	If the accumulative running time of the AC drive exceeds the time set in F8-17, the terminal becomes ON.
13	Frequency limited	If the set frequency exceeds the frequency upper limit or lower limit and the output frequency of the AC drive reaches the upper limit or lower limit, the terminal becomes ON.
14	Torque limited	In speed control mode, if the output torque reaches the torque limit, the AC drive enters the stall protection state and meanwhile the terminal becomes ON.
15	Ready for RUN	If the AC drive main circuit and control circuit become stable, and the AC drive detects no fault and is ready for RUN, the terminal becomes ON.
16	AI1 larger than AI2	When the input of AI1 is larger than the input of AI2, the terminal becomes ON.
17	Frequency upper limit reached	If the running frequency reaches the upper limit, the terminal becomes ON.
18	Frequency lower limit reached (no output at stop)	If the running frequency reaches the lower limit, the terminal becomes ON. In the stop state, the terminal becomes OFF.

Value	Function	Description
19	Undervoltage state output	If the AC drive is in undervoltage state, the terminal becomes ON.
20	Communication setting	Refer to the communication protocol.
21	Reserved	Reserved.
22	Reserved	Reserved.
23	Zero-speed running 2 (having output at stop)	If the output frequency of the AC drive is 0, the terminal becomes ON. In the state of stop, the signal is still ON.
24	Accumulative power-on time reached	If the AC drive accumulative power-on time (F7-13) exceeds the value set in F8-16, the terminal becomes ON.
25	Frequency level detection FDT2 output	Refer to the descriptions of F8-28 and F8-29.
26	Frequency 1 reached	Refer to the descriptions of F8-30 and F8-31.
27	Frequency 2 reached	Refer to the descriptions of F8-32 and F8-33.
28	Current 1 reached	Refer to the descriptions of F8-38 and F8-39.
29	Current 2 reached	Refer to the descriptions of F8-40 and F8-41.
30	Timing reached	If the timing function (F8-42) is valid, the terminal becomes ON after the current running time of the AC drive reaches the set time.
31	A11 input limit exceeded	If A11 input is larger than the value of F8-46 (A11 input voltage upper limit) or lower than the value of F8-45 (A11 input voltage lower limit), the terminal becomes ON.
32	Load becoming 0	If the load becomes 0, the terminal becomes ON.
33	Reverse running	If the AC drive is in the reverse running state, the terminal becomes ON.
34	Zero current state	Refer to the descriptions of F8-28 and F8-29.
35	Module temperature reached	If the heatsink temperature of the inverter module (F7-07) reaches the set module temperature threshold (F8-47), the terminal becomes ON.
36	Software current limit exceeded	Refer to the descriptions of F8-36 and F8-37.
37	Frequency lower limit reached (having output at stop)	If the running frequency reaches the lower limit, the terminal becomes ON. In the stop state, the signal is still ON.
38	Alarm output	If a fault occurs on the AC drive and the AC drive continues to run, the terminal outputs the alarm signal.
39	Motor overheat warning	If the motor temperature reaches the temperature set in F9-58 (Motor overheat warning threshold), the terminal becomes ON. You can view the motor temperature by using U0-34.
40	Current running time reached	If the current running time of AC drive exceeds the value of F8-53, the terminal becomes ON.

Function Code	Parameter Name	Default
F5-06	FMP function selection	0
F5-07	AO1 function selection	0
F5-08	AO2 function selection	1

The output pulse frequency of the FMP terminal ranges from 0.01 kHz to "Maximum FMP output frequency" (F5-09). The value of F5-09 is between 0.01 kHz and 100.00 kHz.

The output range of AO1 and AO2 is 0–10 V or 0–20 mA. The relationship between pulse and analog output ranges and corresponding functions is listed in the following table.

Table 6-6 Relationship between pulse and analog output ranges and corresponding functions

Value	Function	Range (Corresponding to Pulse or Analog Output Range 0.0%–100.0%)
0	Running frequency	0 to maximum output frequency
1	Set frequency	0 to maximum output frequency
2	Output current	0 to 2 times of rated motor current
3	Output torque (absolute value)	0 to 2 times of rated motor torque
4	Output power	0 to 2 times of rated power
5	Output voltage	0 to 1.2 times of rated AC drive voltage
6	Pulse input	0.01–100.00 kHz
7	AI1	0–10 V
8	AI2	0–10 V (or 0–20 mA)
9	AI3	0–0 V
10	Length	0 to maximum set length
11	Count value	0 to maximum count value
12	Communication setting	0.0%–100.0%
13	Motor rotational speed	0 to rotational speed corresponding to maximum output frequency
14	Output current	0.0–1000.0 A
15	Output voltage	0.0–000.0 V
16	Output torque (actual value)	-2 times of rated motor torque to 2 times of rated motor torque

Function Code	Parameter Name	Setting Range	Default
F5-09	Maximum FMP output frequency	0.01–100.00 kHz	50.00 kHz

If the FM terminal is used for pulse output, this parameter is used to set the maximum frequency of pulse output.

Function Code	Parameter Name	Setting Range	Default
F5-10	AO1 offset coefficient	-100.0%~100.0%	0.0%
F5-11	AO1 gain	-10.00~10.00	1.00
F5-12	AO2 offset coefficient	-100.0%~100.0%	0.00%
F5-13	AO2 gain	-10.00~10.00	1.00

These parameters are used to correct the zero drift of analog output and the output amplitude deviation. They can also be used to define the desired AO curve.

If "b" represents zero offset, "k" represents gain, "Y" represents actual output, and "X" represents standard output, the actual output is: $Y = kX + b$.

The zero offset coefficient 100% of AO1 and AO2 corresponds to 10 V (or 20 mA). The standard output refers to the value corresponding to the analog output of 0 to 10 V (or 0 to 20 mA) with no zero offset or gain adjustment.

For example, if the analog output is used as the running frequency, and it is expected that the output is 8 V when the frequency is 0 and 3 V at the maximum frequency, the gain shall be set to -0.50, and the zero offset shall be set to 80%.

Function Code	Parameter Name	Setting Range	Default
F5-17	FMR output delay time	0.0~3600.0s	0.0s
F5-18	Relay 1 output delay time	0.0~3600.0s	0.0s
F5-19	Relay 2 output delay time	0.0~3600.0s	0.0s
F5-20	DO1 output delay time	0.0~3600.0s	0.0s
F5-21	DO2 output delay time	0.0~3600.0s	0.0s

These parameters are used to set the delay time of output terminals FMR, relay 1, relay 2, DO1 and DO2 from status change to actual output.

Function Code	Parameter Name	Setting Range	Default
F5-22	DO valid mode selection	Unit's digit (FMR valid mode)	00000
		0: Positive logic 1: Negative logic	
		Ten's digit (Relay 1 valid mode)	
		0, 1 (same as FMR)	
		Hundred's digit (Relay 2 valid mode)	
		0, 1 (same as FMR)	
		Thousand's digit (DO1 valid mode)	
		0, 1 (same as FMR)	
		Ten thousand's digit (DO2 valid mode)	
		0, 1 (same as FMR)	

It is used to set the logic of output terminals FMR, relay 1, relay 2, DO1 and DO2.

- 0: Positive logic

The output terminal is valid when being connected with COM, and invalid when being disconnected from COM.

- 1: Positive logic

The output terminal is invalid when being connected with COM, and valid when being disconnected from COM.

Group F6: Start/Stop Control

Function Code	Parameter Name	Setting Range	Default
F6-00	Start mode	0: Direct start 1: Rotational speed tracking restart 2: Pre-excited start (asynchronous motor)	0

- 0: Direct start

- If the DC braking time is set to 0, the AC drive starts to run at the startup frequency.
- If the DC braking time is not 0, the AC drive performs DC braking first and then starts to run at the startup frequency. It is applicable to small-inertia load application where the motor is likely to rotate at startup.

- 1: Rotational speed tracking restart

The AC drive judges the rotational speed and direction of the motor first and then starts at the tracked frequency. Such smooth start has no impact on the rotating motor. It is applicable to the restart upon instantaneous power failure of large-inertia load. To ensure the performance of rotational speed tracking restart, set the motor parameters in group F1 correctly.

- 2: Pre-excited start (asynchronous motor)

It is valid only for asynchronous motor and used for building the magnetic field before the motor runs. For pre-excited current and pre-excited time, see parameters of F6-05 and F6-06.

- If the pre-excited time is 0, the AC drive cancels pre-excitation and starts to run at startup frequency.
- If the pre-excited time is not 0, the AC drive pre-excites first before startup, improving the dynamic response of the motor.

Function Code	Parameter Name	Setting Range	Default
F6-01	Rotational speed tracking mode	0: From frequency at stop 1: From zero speed 2: From maximum frequency	0

To complete the rotational speed tracking process within the shortest time, select the proper mode in which the AC drive tracks the motor rotational speed.

- 0: From frequency at stop
It is the commonly selected mode.
- 1: From zero frequency
It is applicable to restart after a long time of power failure.
- 2: From the maximum frequency
It is applicable to the power-generating load.

Function Code	Parameter Name	Setting Range	Default
F6-02	Rotational speed tracking speed	1-100	20

In the rotational speed tracking restart mode, select the rotational speed tracking speed. The larger the value is, the faster the tracking is. However, too large value may cause unreliable tracking.

Function Code	Parameter Name	Setting Range	Default
F6-03	Startup frequency	0.00-10.00 Hz	0.00 Hz
F6-04	Startup frequency holding time	0.0-100.0s	0.0s

To ensure the motor torque at AC drive startup, set a proper startup frequency. In addition, to build excitation when the motor starts up, the startup frequency must be held for a certain period.

The startup frequency (F6-03) is not restricted by the frequency lower limit. If the set target frequency is lower than the startup frequency, the AC drive will not start and stays in the standby state.

During switchover between forward rotation and reverse rotation, the startup frequency holding time is disabled. The holding time is not included in the acceleration time but in the running time of simple PLC.

Example 1:

F0-03 = 0	The frequency source is digital setting.
F0-08 = 2.00 Hz	The digital setting frequency is 2.00 Hz.
F6-03 = 5.00 Hz	The startup frequency is 5.00 Hz.
F6-04 = 2.0s	The startup frequency holding time is 2.0s.

In this example, the AC drive stays in the standby state and the output frequency is 0.00 Hz.

Example 2:

F0-03 = 0	The frequency source is digital setting.
F0-08 = 10.00 Hz	The digital setting frequency is 10.00 Hz.
F6-03 = 5.00 Hz	The startup frequency is 5.00 Hz.
F6-04 = 2.0s	The startup frequency holding time is 2.0s.

In this example, the AC drive accelerates to 5.00 Hz, and then accelerates to the set frequency 10.00 Hz after 2s.

Function Code	Parameter Name	Setting Range	Default
F6-05	Startup DC braking current/Pre-excited current	0%–100%	0%
F6-06	Startup DC braking time/Pre-excited time	0.0–100.0s	0.0s

Startup DC braking is generally used during restart of the AC drive after the rotating motor stops. Pre-excitation is used to make the AC drive build magnetic field for the asynchronous motor before startup to improve the responsiveness.

Startup DC braking is valid only for direct start (F6-00 = 0). In this case, the AC drive performs DC braking at the set startup DC braking current. After the startup DC braking time, the AC drive starts to run. If the startup DC braking time is 0, the AC drive starts directly without DC braking. The larger the startup DC braking current is, the larger the braking force is.

If the startup mode is pre-excited start (F6-00 = 3), the AC drive builds magnetic field based on the set pre-excited current. After the pre-excited time, the AC drive starts to run. If the pre-excited time is 0, the AC drive starts directly without pre-excitation.

The startup DC braking current or pre-excited current is a percentage relative to the base value.

- If the rated motor current is less than or equal to 80% of the rated AC drive current, the base value is the rated motor current.
- If the rated motor current is greater than 80% of the rated AC drive current, the base value is 80% of the rated AC drive current.

Function Code	Parameter Name	Setting Range	Default
F6-07	Acceleration/ Deceleration mode	0: Linear acceleration/deceleration 1: S-curve acceleration/deceleration A 2: S-curve acceleration/deceleration B	0

It is used to set the frequency change mode during the AC drive start and stop process.

- 0: Linear acceleration/deceleration

The output frequency increases or decreases in linear mode. The MD380 provides four group of acceleration/deceleration time, which can be selected by using F4-00 to F4-08.

- 1: S-curve acceleration/deceleration A

The output frequency increases or decreases along the S curve. This mode is generally used in the applications where start and stop processes are relatively smooth, such as elevator and conveyor belt. F6-08 and F6-09 respectively define the time proportions of the start segment and the end segment.

- 2: S-curve acceleration/deceleration B

In this curve, the rated motor frequency f_b is always the inflexion point. This mode is usually used in applications where acceleration/deceleration is required at the speed higher than the rated frequency.

When the set frequency is higher than the rated frequency, the acceleration/ deceleration time is:

$$t = \left(\frac{4}{9} \times \left(\frac{f}{f_b} \right)^2 + \frac{5}{9} \right) \times T$$

In the formula, f is the set frequency, f_b is the rated motor frequency and T is the acceleration time from 0 Hz to f_b .

Function Code	Parameter Name	Setting Range	Default
F6-08	Time proportion of S-curve start segment	0.0% to (100.0% – F6-09)	30.0%
F6-09	Time proportion of S-curve end segment	0.0% to (100.0% – F6-08)	30.0%

These two parameters respectively define the time proportions of the start segment and the end segment of S-curve acceleration/deceleration. They must satisfy the requirement: F6-08 + F6-09 ≤ 100.0%.

In Figure 6-12, t1 is the time defined in F6-08, within which the slope of the output frequency change increases gradually. t2 is the time defined in F6-09, within which the slope of the output frequency change gradually decreases to 0. Within the time between t1 and t2, the slope of the output frequency change remains unchanged, that is, linear acceleration/ deceleration.

Figure 6-12 S-curve acceleration/deceleration A

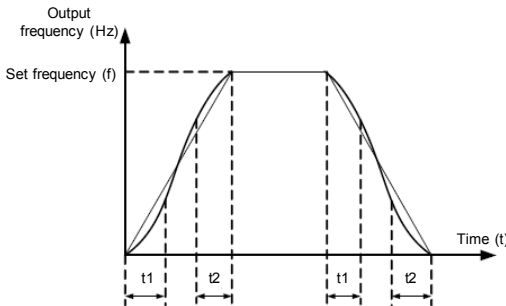
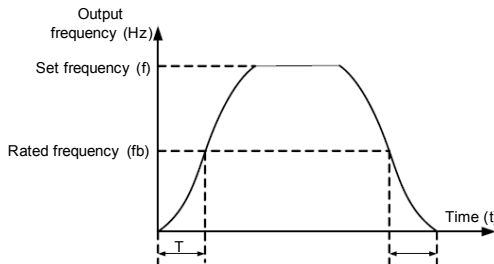

Figure 6-13 S-curve acceleration/deceleration B



Function Code	Parameter Name	Setting Range	Default
F6-10	Stop mode	0: Decelerate to stop 1: Coast to stop	0

- 0: Decelerate to stop

After the stop command is enabled, the AC drive decreases the output frequency according to the deceleration time and stops when the frequency decreases to zero.

- 1: Coast to stop

After the stop command is enabled, the AC drive immediately stops the output. The motor will coast to stop based on the mechanical inertia.

Function Code	Parameter Name	Setting Range	Default
F6-11	Initial frequency of stop DC braking	0.00 Hz to maximum frequency	0.00 Hz
F6-12	Waiting time of stop DC braking	0.0–36.0s	0.0s
F6-13	Stop DC braking current	0%–100%	0%
F6-14	Stop DC braking time	0.0–36.0s	0.0s

- F6-11 (Initial frequency of stop DC braking)

During the process of decelerating to stop, the AC drive starts DC braking when the running frequency is lower than the value set in F6-11.

- F6-12 (Waiting time of stop DC braking)

When the running frequency decreases to the initial frequency of stop DC braking, the AC drive stops output for a certain period and then starts DC braking. This prevents faults such as overcurrent caused due to DC braking at high speed.

- F6-13 (Stop DC braking current)

This parameter specifies the output current at DC braking and is a percentage relative to the base value.

- If the rated motor current is less than or equal to 80% of the rated AC drive current, the base value is the rated motor current.
- If the rated motor current is greater than 80% of the rated AC drive current, the base value is 80% of the rated AC drive current.

- F6-14 (Stop DC braking time)

This parameter specifies the holding time of DC braking. If it is set to 0, DC braking is cancelled.

The stop DC braking process is shown in the following figure.

Figure 6-14 Stop DC braking process

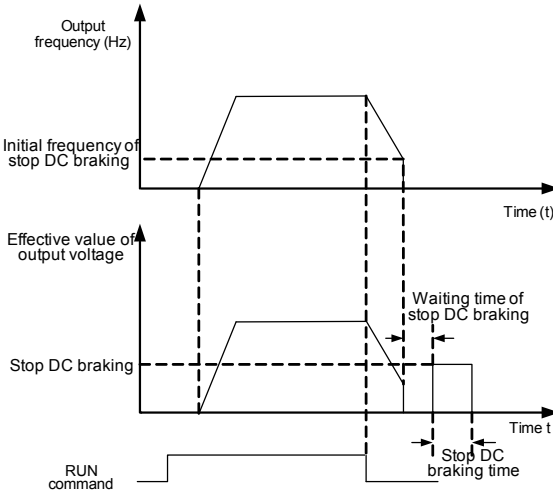

Function Code	Parameter Name	Setting Range	Default
F6-15	Brake use ratio	0%–100%	100%

It is valid only for the AC drive with internal braking unit and used to adjust the duty ratio of the braking unit. The larger the value of this parameter is, the better the braking result will be. However, too larger value causes great fluctuation of the AC drive bus voltage during the braking process.

Group F7: Operation Panel and Display

Function Code	Parameter Name	Setting Range	Default
F7-01	MF.K Key function selection	0: MF.K key disabled 1: Switchover between operation panel control and remote command control (terminal or communication) 2: Switchover between forward rotation and reverse rotation 3: Forward JOG 4: Reverse JOG	0

MF.K key refers to multifunctional key. You can set the function of the MF.K key by using this parameter. You can perform switchover by using this key both in stop or running state.

- 0: MF.K key disabled
This key is disabled.
- 1: Switchover between operation panel control and remote command control (terminal or communication)
You can perform switchover from the current command source to the operation panel control (local operation). If the current command source is operation panel control, this key is invalid.
- 2: Switchover between forward rotation and reverse rotation
You can change the direction of the frequency reference by using the MF.K key. It is valid only when the current command source is operation panel control.
- 3: Forward JOG
You can perform forward JOG (FJOG) by using the MF.K key.
- 4: Reverse JOG
You can perform reverse JOG (FJOG) by using the MF.K key.

Function Code	Parameter Name	Setting Range	Default
F7-02	STOP/RESET key function	0: STOP/RESET key enabled only in operation panel control 1: STOP/RESET key enabled in any operation mode	1

Function Code	Parameter Name	Setting Range	Default
F7-03	LED display running parameters 1	0000–FFFF <div style="display: flex; justify-content: space-around; border: 1px solid black; padding: 2px;"> 76543210 </div> <ul style="list-style-type: none"> Running frequency1 (Hz) Set frequency (Hz) Bus voltage (V) Output voltage (V) Output current (A) Output power (kW) Output torque (%) DI input status (V) <div style="display: flex; justify-content: space-around; border: 1px solid black; padding: 2px; margin-top: 10px;"> 15141312111098 </div> <ul style="list-style-type: none"> DO output status AI1 voltage (V) AI2 voltage (V) AI3 voltage (V) Count value Length value Load speed display PID setting <p>If a parameter needs to be displayed during the running, set the corresponding bit to 1, and set F7-03 to the hexadecimal equivalent of this binary number.</p>	1F

Function Code	Parameter Name	Setting Range	Default
F7-04	LED display running parameters 2	0000-FFFF <div style="display: flex; justify-content: space-around; border: 1px solid black; padding: 2px;"> 76543210 </div> <ul style="list-style-type: none"> _____ PID feedback _____ PLC stage _____ Pulse setting frequency(kHz) _____ Running frequency2 _____ Remaining running time _____ AI1 voltage before correction _____ AI2 voltage before correction _____ AI3 voltage before correction <div style="display: flex; justify-content: space-around; border: 1px solid black; padding: 2px; margin-top: 10px;"> 15141312111098 </div> <ul style="list-style-type: none"> _____ Linear speed _____ Current power-on time (Hour) _____ Current running time(Minute) _____ Pulse setting frequency (Hz) _____ Communication setting value _____ Encoder feedback speed (Hz) _____ Main frequency X display (Hz) _____ Auxiliary frequency Y display (Hz) <p>If a parameter needs to be displayed during the running, set the corresponding bit to 1, and set F7-03 to the hexadecimal equivalent of this binary number.</p>	0

These two parameters are used to set the parameters that can be viewed when the AC drive is in the running state. You can view a maximum of 32 running state parameters that are displayed from the lowest bit of F7-03.

Function Code	Parameter Name	Setting Range	Default
F7-05	LED display stop parameters	0000–FFFF 	0

If a parameter needs to be displayed during the running, set the corresponding bit to 1, and set F7-05 to the hexadecimal equivalent of this binary number.

Function Code	Parameter Name	Setting Range	Default
F7-06	Load speed display coefficient	0.0001–6.5000	1.0000

This parameter is used to adjust the relationship between the output frequency of the AC drive and the load speed. For details, see the description of F7-12.

Function Code	Parameter Name	Setting Range	Default
F7-07	Heatsink temperature of inverter module	0.0–100.0° C	-

It is used to display the insulated gate bipolar transistor (IGBT) temperature of the inverter module, and the IGBT overheat protection value of the inverter module depends on the model.

Function Code	Parameter Name	Setting Range	Default
F7-08	Temporary software version	0.0–100.0° C	-

It is used to display the temporary software version of the control board.

Function Code	Parameter Name	Setting Range	Default
F7-09	Accumulative running time	0-65535 h	-

It is used to display the accumulative running time of the AC drive. After the accumulative running time reaches the value set in F8-17, the terminal with the digital output function 12 becomes ON.

Function Code	Parameter Name	Setting Range	Default
F7-10	Product number	AC drive product number	-
F7-11	Software version	Software version of control board	-
F7-12	Number of decimal places for load speed display	0: 0 decimal place 1: 1 decimal place 2: 2 decimal places 3: 3 decimal places	1

F7-12 is used to set the number of decimal places for load speed display. The following gives an example to explain how to calculate the load speed:

Assume that F7-06 (Load speed display coefficient) is 2.000 and F7-12 is 2 (2 decimal places). When the running frequency of the AC drive is 40.00 Hz, the load speed is $40.00 \times 2.000 = 80.00$ (display of 2 decimal places).

If the AC drive is in the stop state, the load speed is the speed corresponding to the set frequency, namely, "set load speed". If the set frequency is 50.00 Hz, the load speed in the stop state is $50.00 \times 2.000 = 100.00$ (display of 2 decimal places).

Function Code	Parameter Name	Setting Range	Default
F7-13	Accumulative power-on time	0-65535 h	0 h

It is used to display the accumulative power-on time of the AC drive since the delivery. If the time reaches the set power-on time (F8-17), the terminal with the digital output function 24 becomes ON.

Function Code	Parameter Name	Setting Range	Default
F7-14	Accumulative power consumption	0-65535 kWh	/

It is used to display the accumulative power consumption of the AC drive until now.

Group F8: Auxiliary Functions

Function Code	Parameter Name	Setting Range	Default
F8-00	JOG running frequency	0.00 Hz to maximum frequency	2.00 Hz
F8-01	JOG acceleration time	0.0-6500.0s	20.0s
F8-02	JOG deceleration time	0.0-6500.0s	20.0s

These parameters are used to define the set frequency and acceleration/deceleration time of the AC drive when jogging. The startup mode is "Direct start" (F6-00 = 0) and the stop mode is "Decelerate to stop" (F6-10 = 0) during jogging.

Function Code	Parameter Name	Setting Range	Default
F8-03	Acceleration time 2	0.0–6500.0s	Model dependent
F8-04	Deceleration time 2	0.0–6500.0s	Model dependent
F8-05	Acceleration time 3	0.0–6500.0s	Model dependent
F8-06	Deceleration time 3	0.0–6500.0s	Model dependent
F8-07	Acceleration time 4	0.0–500.0s	Model dependent
F8-08	Deceleration time 4	0.0–6500.0s	Model dependent

The MD380 provides a total of four groups of acceleration/deceleration time, that is, the preceding three groups and the group defined by F0-17 and F0-18. Definitions of four groups are completely the same. You can switch over between the four groups of acceleration/deceleration time through different state combinations of DI terminals. For more details, see the descriptions of F4-01 to F4-05.

Function Code	Parameter Name	Setting Range	Default
F8-09	Jump frequency 1	0.00 Hz to maximum frequency	0.00 Hz
F8-10	Jump frequency 2	0.00 Hz to maximum frequency	0.00 Hz
F8-11	Frequency jump amplitude	0.00 Hz to maximum frequency	0.00 Hz

If the set frequency is within the frequency jump range, the actual running frequency is the jump frequency close to the set frequency. Setting the jump frequency helps to avoid the mechanical resonance point of the load.

The MD380 supports two jump frequencies. If both are set to 0, the frequency jump function is disabled. The principle of the jump frequencies and jump amplitude is shown in the following figure.

Figure 6-15 Principle of the jump frequencies and jump amplitude

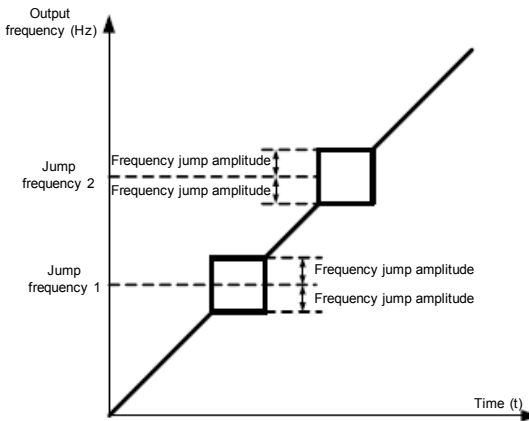

Function Code	Parameter Name	Setting Range	Default
F8-12	Forward/Reverse rotation dead-zone time	0.0–3000.0s	0.0s

It is used to set the time when the output is 0 Hz at transition of the AC drive forward rotation and reverse rotation, as shown in the following figure.

Figure 6-16 Forward/Reverse rotation dead-zone time

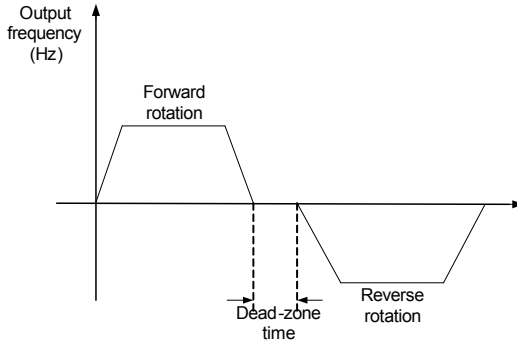

Function Code	Parameter Name	Setting Range	Default
F8-13	Reverse control	0: Enabled 1: Disabled	0

It is used to set whether the AC drive allows reverse rotation. In the applications where reverse rotation is prohibited, set this parameter to 1.

Function Code	Parameter Name	Setting Range	Default
F8-14	Running mode when set frequency lower than frequency lower limit	0: Run at frequency lower limit 1: Stop 2: Run at zero speed	0

It is used to set the AC drive running mode when the set frequency is lower than the frequency lower limit. The MD380 provides three running modes to satisfy requirements of various applications.

Function Code	Parameter Name	Setting Range	Default
F8-15	Droop control	0.00–10.00 Hz	0.00 Hz

This function is used for balancing the workload allocation when multiple motors are used to drive the same load. The output frequency of the AC drives decreases as the load increases. You can reduce the workload of the motor under load by decreasing the output frequency for this motor, implementing workload balancing between multiple motors.

Function Code	Parameter Name	Setting Range	Default
F8-16	Accumulative power-on time threshold	0–65000 h	0 h

If the accumulative power-on time (F7-13) reaches the value set in this parameter, the corresponding DO terminal becomes ON.

For example, combining virtual DI/DO functions, to implement the function that the AC drive reports an alarm when the actual accumulative power-on time reaches the threshold of 100 hours, perform the setting as follows:

- 1) Set virtual DI1 to user-defined fault 1: A1-00 = 44.
- 2) Set that the valid state of virtual DI1 is from virtual DO1: A1-05 = 0000.
- 3) Set virtual DO1 to power-on time reached: A1-11 = 24.
- 4) Set the accumulative power-on time threshold to 100 h: F8-16 = 100 h.

Then, the AC drive reports Err27 when the accumulative power-on time reaches 100 hours.

Function Code	Parameter Name	Setting Range	Default
F8-17	Accumulative running time threshold	0–65000 h	0 h

It is used to set the accumulative running time threshold of the AC drive. If the accumulative running time (F7-09) reaches the value set in this parameter, the corresponding DO terminal becomes ON.

Function Code	Parameter Name	Setting Range	Default
F8-18	Startup protection	0: No 1: Yes	0

This parameter is used to set whether to enable the safety protection. If it is set to 1, the AC drive does not respond to the run command valid upon AC drive power-on (for example, an input terminal is ON before power-on). The AC drive responds only after the run command is cancelled and becomes valid again.

In addition, the AC drive does not respond to the run command valid upon fault reset of the AC drive. The run protection can be disabled only after the run command is cancelled.

In this way, the motor can be protected from responding to run commands upon power-on or fault reset in unexpected conditions.

Function Code	Parameter Name	Setting Range	Default
F8-19	Frequency detection value (FDT1)	0.00 Hz to maximum frequency	50.00 Hz
F8-20	Frequency detection hysteresis (FDT hysteresis 1)	0.0%–100.0% (FDT1 level)	5.0%

If the running frequency is higher than the value of F8-19, the corresponding DO terminal becomes ON. If the running frequency is lower than value of F8-19, the DO terminal goes OFF

These two parameters are respectively used to set the detection value of output frequency and hysteresis value upon cancellation of the output. The value of F8-20 is a percentage of the hysteresis frequency to the frequency detection value (F8-19).

The FDT function is shown in the following figure.

Figure 6-17 FDT level

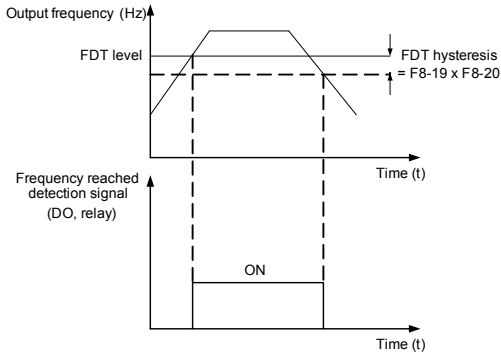

Function Code	Parameter Name	Setting Range	Default
F8-21	Detection range of frequency reached	0.00–100% (maximum frequency)	0.0%

If the AC drive running frequency is within the certain range of the set frequency, the corresponding DO terminal becomes ON.

This parameter is used to set the range within which the output frequency is detected to reach the set frequency. The value of this parameter is a percentage relative to the maximum frequency. The detection range of frequency reached is shown in the following figure.

Figure 6-18 Detection range of frequency reached

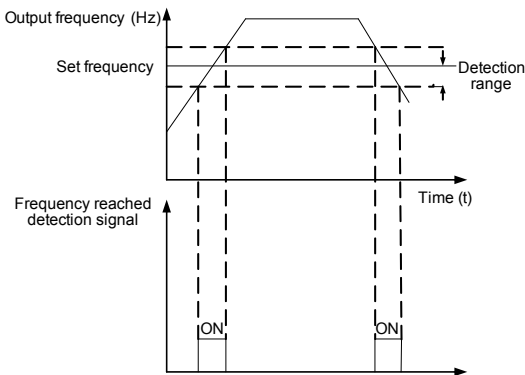

Function Code	Parameter Name	Setting Range	Default
F8-22	Jump frequency during acceleration/deceleration	0: Disabled 1: Enabled	0

It is used to set whether the jump frequencies are valid during acceleration/deceleration.

When the jump frequencies are valid during acceleration/deceleration, and the running frequency is within the frequency jump range, the actual running frequency will jump over the set frequency jump amplitude (rise directly from the lowest jump frequency to the highest jump frequency). The following figure shows the diagram when the jump frequencies are valid during acceleration/deceleration.

Figure 6-19 Diagram when the jump frequencies are valid during acceleration/deceleration

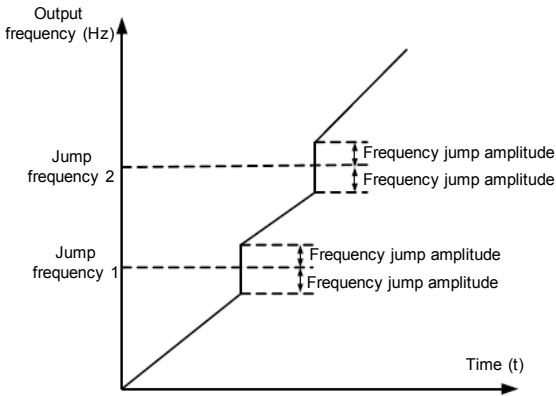

Function Code	Parameter Name	Setting Range	Default
F8-25	Frequency switchover point between acceleration time 1 and acceleration time 2	0.00 Hz to maximum frequency	0.00 Hz
F8-26	Frequency switchover point between deceleration time 1 and deceleration time 2	0.00 to maximum frequency	0.00 Hz

This function is valid when motor 1 is selected and acceleration/deceleration time switchover is not performed by means of DI terminal. It is used to select different groups of acceleration/deceleration time based on the running frequency range rather than DI terminal during the running process of the AC drive.

Figure 6-20 Acceleration/deceleration time switchover

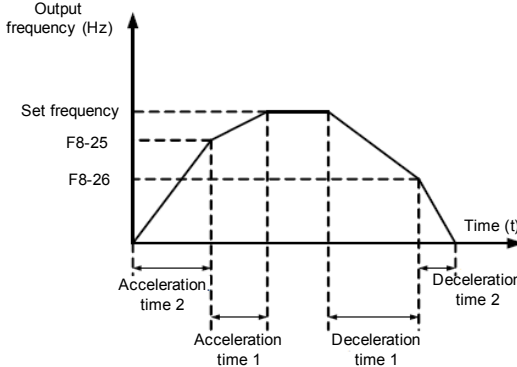

During acceleration, if the running frequency is smaller than the value of F8-25, acceleration time 2 is selected. If the running frequency is larger than the value of F8-25, acceleration time 1 is selected.

During deceleration, if the running frequency is larger than the value of F8-26, deceleration time 2 is selected. If the running frequency is smaller than the value of F8-26, deceleration time 1 is selected.

Function Code	Parameter Name	Setting Range	Default
F8-27	Terminal JOG preferred	0: Disabled 1: Enabled	0

It is used to set whether terminal JOG is preferred.

If terminal JOG is preferred, the AC drive switches to terminal JOG running state when there is a terminal JOG command during the running process of the AC drive.

Function Code	Parameter Name	Setting Range	Default
F8-28	Frequency detection value (FDT2)	0.00 to maximum frequency	50.00 Hz
F8-29	Frequency detection hysteresis (FDT hysteresis 2)	0.0%–100.0% (FDT2 level)	5.0%

The frequency detection function is the same as FDT1 function. For details, refer to the descriptions of F8-19 and F8-20.

Function Code	Parameter Name	Setting Range	Default
F8-30	Any frequency reaching detection value 1	0.00 Hz to maximum frequency	50.00 Hz
F8-31	Any frequency reaching detection amplitude 1	0.0%–100.0% (maximum frequency)	0.0%
F8-32	Any frequency reaching detection value 2	0.00 Hz to maximum frequency	50.00 Hz

Function Code	Parameter Name	Setting Range	Default
F8-33	Any frequency reaching detection amplitude 2	0.0%–100.0% (maximum frequency)	0.0%

If the output frequency of the AC drive is within the positive and negative amplitudes of the any frequency reaching detection value, the corresponding DO becomes ON.

The MD380 provides two groups of any frequency reaching detection parameters, including frequency detection value and detection amplitude, as shown in the following figure.

Figure 6-21 Any frequency reaching detection

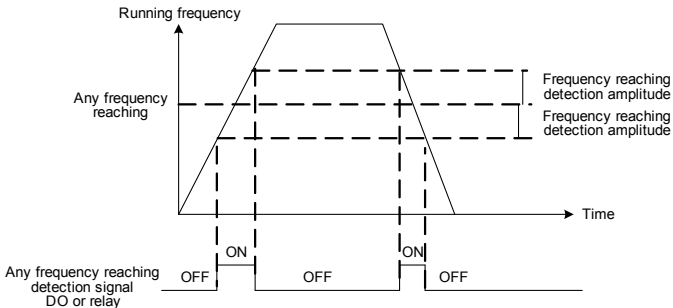

Function Code	Parameter Name	Setting Range	Default
F8-34	Zero current detection level	0.0%–300.0% (rated motor current)	5.0%
F8-35	Zero current detection delay time	0.00–600.00s	0.10s

If the output current of the AC drive is equal to or less than the zero current detection level and the duration exceeds the zero current detection delay time, the corresponding DO becomes ON. The zero current detection is shown in the following figure.

Figure 6-22 Zero current detection

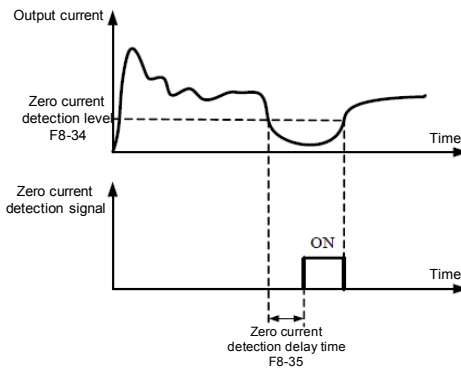

Function Code	Parameter Name	Setting Range	Default
F8-36	Output overcurrent threshold	0.0% (no detection) 0.1%–300.0% (rated motor current)	200.0%
F8-37	Output overcurrent detection delay time	0.00–600.00s	0.00s

If the output current of the AC drive is equal to or higher than the overcurrent threshold and the duration exceeds the detection delay time, the corresponding DO becomes ON. The output overcurrent detection function is shown in the following figure.

Figure 6-23 Output overcurrent detection

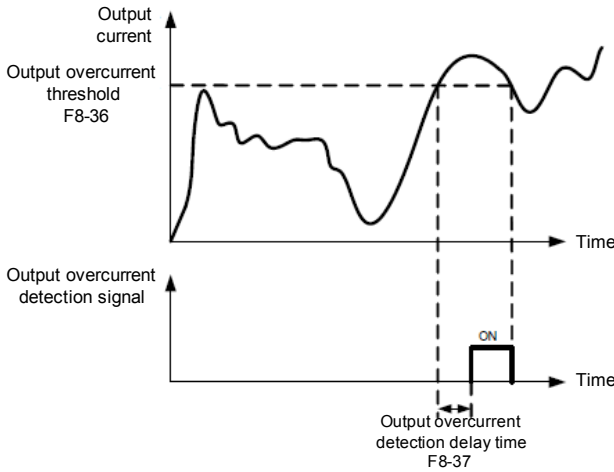

Function Code	Parameter Name	Setting Range	Default
F8-38	Any current reaching 1	0.0%–300.0% (rated motor current)	100.0%
F8-39	Any current reaching 1 amplitude	0.0%–300.0% (rated motor current)	0.0%
F8-40	Any current reaching 2	0.0%–300.0% (rated motor current)	100.0%
F8-41	Any current reaching 2 amplitude	0.0%–300.0% (rated motor current)	0.0%

If the output current of the AC drive is within the positive and negative amplitudes of any current reaching detection value, the corresponding DO becomes ON.

The MD380 provides two groups of any current reaching detection parameters, including current detection value and detection amplitudes, as shown in the following figure.

Figure 6-24 Any current reaching detection

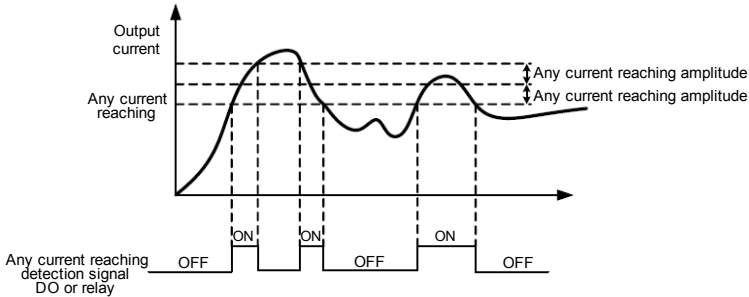

Function Code	Parameter Name	Setting Range	Default
F8-42	Timing function	0: Disabled 1: Enabled	0
F8-43	Timing duration source	0: F8-44 1: AI1 2: AI2 3: AI3 (100% of analog input corresponds to the value of F8-44)	0
F8-44	Timing duration	0.0–6500.0 min	0.0 min

These parameters are used to implement the AC drive timing function.

If F8-42 is set to 1, the AC drive starts to time at startup. When the set timing duration is reached, the AC drive stops automatically and meanwhile the corresponding DO becomes ON.

The AC drive starts timing from 0 each time it starts up and the remaining timing duration can be queried by U0-20.

The timing duration is set in F8-43 and F8-44, in unit of minute.

Function Code	Parameter Name	Setting Range	Default
F8-45	AI1 input voltage lower limit	0.00 V to F8-46	3.10 V
F8-46	AI1 input voltage upper limit	F8-45 to 10.00 V	6.80 V

These two parameters are used to set the limits of the input voltage to provide protection on the AC drive. When the AI1 input is larger than the value of F8-46 or smaller than the value of F8-45, the corresponding DO becomes ON, indicating that AI1 input exceeds the limit.

Function Code	Parameter Name	Setting Range	Default
F8-47	Module temperature threshold	0–75 °C	75 °C

When the heatsink temperature of the AC drive reaches the value of this parameter, the corresponding DO becomes ON, indicating that the module temperature reaches the threshold.

Function Code	Parameter Name	Setting Range	Default
F8-48	Cooling fan control	0: Fan working during running 1: Fan working continuously	0

It is used to set the working mode of the cooling fan. If this parameter is set to 0, the fan works when the AC drive is in running state. When the AC drive stops, the cooling fan works if the heatsink temperature is higher than 40°C, and stops working if the heatsink temperature is lower than 40°C.

If this parameter is set to 1, the cooling fan keeps working after power-on.

Function Code	Parameter Name	Setting Range	Default
F8-49	Wakeup frequency	Dormant frequency (F8-51) to maximum frequency (F0-10)	0.00 Hz
F8-50	Wakeup delay time	0.0–6500.0s	0.0s
F8-51	Dormant frequency	0.00 Hz to wakeup frequency (F8-49)	0.00 Hz
F8-52	Dormant delay time	0.0–6500.0s	0.0s

These parameters are used to implement the dormant and wakeup functions in the water supply application.

When the AC drive is in running state, the AC drive enters the dormant state and stops automatically after the dormant delay time (F8-52) if the set frequency is lower than or equal to the dormant frequency (F8-51).

When the AC drive is in dormant state and the current running command is effective, the AC drives starts up after the wakeup delay time (F8-50) if the set frequency is higher than or equal to the wakeup frequency (F8-49).

Generally, set the wakeup frequency equal to or higher than the dormant frequency. If the wakeup frequency and dormant frequency are set to 0, the dormant and wakeup functions are disabled.

When the dormant function is enabled, if the frequency source is PID, whether PID operation is performed in the dormant state is determined by FA-28. In this case, select PID operation enabled in the stop state (FA-28 = 1).

Function Code	Parameter Name	Setting Range	Default
F8-53	Current running time reached	0.0–6500.0 min	0.0 min

If the current running time reaches the value set in this parameter, the corresponding DO becomes ON, indicating that the current running time is reached.

Function Code	Parameter Name	Setting Range	Default
F8-54	Output power correction coefficient	0.00%–200.0%	100.0%

When the output power (U0-05) is not equal to the required value, you can perform linear correction on output power by using this parameter.

Group F9: Fault and Protection

Function Code	Parameter Name	Setting Range	Default
F9-00	Motor overload protection selection	0: Disabled 1: Enabled	1
F9-01	Motor overload protection gain	0.20–10.00	1.00

- F9-00 = 0

The motor overload protective function is disabled. The motor is exposed to potential damage due to overheating. A thermal relay is suggested to be installed between the AC drive and the motor.

- F9-00 = 1

The AC drive judges whether the motor is overloaded according to the inverse time-lag curve of the motor overload protection.

The inverse time-lag curve of the motor overload protection is:

$220\% \times F9-01 \times \text{rated motor current}$ (if the load remains at this value for one minute, the AC drive reports motor overload fault), or

$150\% \times F9-01 \times \text{rated motor current}$ (if the load remains at this value for 60 minutes, the AC drive reports motor overload fault)

Set F9-01 properly based on the actual overload capacity. If the value of F9-01 is set too large, damage to the motor may result because the motor overheats but the AC drive does not report the alarm.

Function Code	Parameter Name	Setting Range	Default
F9-02	Motor overload warning coefficient	50%–100%	80%

This function is used to give a warning signal to the control system via DO before motor overload protection. This parameter is used to determine the percentage, at which pre-warning is performed before motor overload. The larger the value is, the less advanced the pre-warning will be.

When the accumulative output current of the AC drive is greater than the value of the overload inverse time-lag curve multiplied by F9-02, the DO terminal on the AC drive allocated with function 6 (Motor overload pre-warning) becomes ON.

Function Code	Parameter Name	Setting Range	Default
F9-03	Overvoltage stall gain	0 (no stall overvoltage)–100	0
F9-04	Overvoltage stall protective voltage	120%–150%	130%

When the DC bus voltage exceeds the value of F9-04 (Overvoltage stall protective voltage) during deceleration of the AC drive, the AC drive stops deceleration and keeps the present running frequency. After the bus voltage declines, the AC drive continues to decelerate.

F9-03 (Overvoltage stall gain) is used to adjust the overvoltage suppression capacity of the AC drive. The larger the value is, the greater the overvoltage suppression capacity will be.

In the prerequisite of no overvoltage occurrence, set F9-03 to a small value.

For small-inertia load, the value should be small. Otherwise, the system dynamic response will be slow. For large-inertia load, the value should be large. Otherwise, the suppression result will be poor and an overvoltage fault may occur.

If the overvoltage stall gain is set to 0, the overvoltage stall function is disabled. The overvoltage stall protective voltage setting 100% corresponds to the base values in the following table:

Table 6-7 Overvoltage stall protective voltage setting 100% corresponds to base values

Voltage Class	Corresponding Base Value
Single-phase 220 V	290 V
Three-phase 220 V	290 V
Three-phase 380 V	530 V
Three-phase 480 V	620 V
Three-phase 690 V	880 V

Function Code	Parameter Name	Setting Range	Default
F9-05	Overcurrent stall gain	0–100	20
F9-06	Overcurrent stall protective current	100%–200%	150%

When the output current exceeds the overcurrent stall protective current during acceleration/ deceleration of the AC drive, the AC drive stops acceleration/deceleration and keeps the present running frequency. After the output current declines, the AC drive continues to accelerate/decelerate.

F9-05 (Overcurrent stall gain) is used to adjust the overcurrent suppression capacity of the AC drive. The larger the value is, the greater the overcurrent suppression capacity will be. In the prerequisite of no overcurrent occurrence, set tF9-05 to a small value.

For small-inertia load, the value should be small. Otherwise, the system dynamic response will be slow. For large-inertia load, the value should be large. Otherwise, the suppression result will be poor and overcurrent fault may occur.

If the overcurrent stall gain is set to 0, the overcurrent stall function is disabled.

Figure 6-25 Diagram of the overcurrent stall protection function

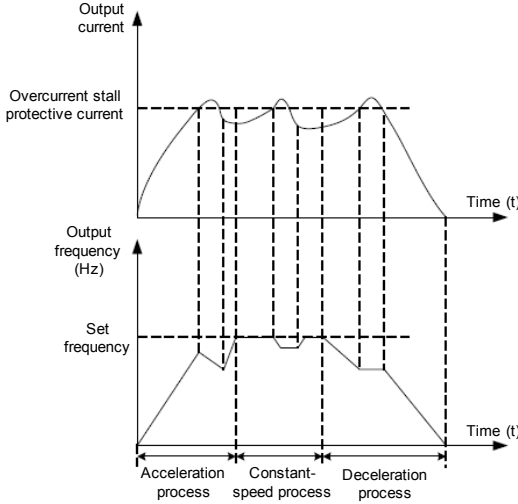

Function Code	Parameter Name	Setting Range	Default
F9-07	Short-circuit to ground upon power-on	0: Disabled 1: Enabled	1

It is used to determine whether to check the motor is short-circuited to ground at power-on of the AC drive. If this function is enabled, the AC drive's UVW will have voltage output a while after power-on.

Function Code	Parameter Name	Setting Range	Default
F9-09	Fault auto reset times	0-20	0

It is used to set the times of fault auto resets if this function is used. After the value is exceeded, the AC drive will remain in the fault state.

Function Code	Parameter Name	Setting Range	Default
F9-10	DO action during fault auto reset	0: Not act 1: Act	0

It is used to decide whether the DO acts during the fault auto reset if the fault auto reset function is selected.

Function Code	Parameter Name	Setting Range	Default
F9-11	Time interval of fault auto reset	0.1s-100.0s	1.0s

It is used to set the waiting time from the alarm of the AC drive to fault auto reset.

Function Code	Parameter Name	Setting Range	Default
F9-12	Input phase loss protection/contactor energizing protection selection	Unit's digit: Input phase loss protection Ten's digit: Contactor energizing protection 0: Disabled 1: Enabled	11

It is used to determine whether to perform input phase loss or contactor energizing protection.

The MD380 models that provide this function are listed in the following table.

Table 6-8 MD380 models providing the input phase loss or contactor energizing protection function

Voltage Class	Models
Single-phase 220 V	None
Three-phase 220 V	11 kW G model
Three-phase 380 V	18.5 kW G model
Three-phase 690 V	18.5 kW G model

For every voltage class, the MD380 AC drives of powers equal to or greater than those listed in the preceding table provide the function of input phase loss or contactor energizing protection. The MD380 AC drives below the power listed in the table do not have the function no matter whether F9-12 is set to 0 or 1.

Function Code	Parameter Name	Setting Range	Default
F9-13	Output phase loss protection selection	0: Disabled 1: Enabled	1

It is used to determine whether to perform output phase loss protection.

Function Code	Name	Setting Range
F9-14	1st fault type	0-99
F9-15	2nd fault type	
F9-16	3rd (latest) fault type	

It is used to record the types of the most recent three faults of the AC drive. 0 indicates no fault. For possible causes and solution of each fault, refer to Chapter 8.

Function Code	Parameter Name	Description
F9-17	Frequency upon 3rd fault	It displays the frequency when the latest fault occurs.
F9-18	Current upon 3rd fault	It displays the current when the latest fault occurs.
F9-19	Bus voltage upon 3rd fault	It displays the bus voltage when the latest fault occurs.

Function Code	Parameter Name	Description																				
F9-20	DI status upon 3rd fault	<p>It displays the status of all DI terminals when the latest fault occurs.</p> <p>The sequence is as follows:</p> <table border="1" style="margin-left: auto; margin-right: auto;"> <tr> <td>BIT9</td><td>BIT8</td><td>BIT7</td><td>BIT6</td><td>BIT5</td><td>BIT4</td><td>BIT3</td><td>BIT2</td><td>BIT1</td><td>BIT0</td> </tr> <tr> <td>DI0</td><td>DI9</td><td>DI8</td><td>DI7</td><td>DI6</td><td>DI5</td><td>DI4</td><td>DI3</td><td>DI2</td><td>DI1</td> </tr> </table> <p>If a DI is ON, the setting is 1. If the DI is OFF, the setting is 0. The value is the equivalent decimal number converted from the DI status..</p>	BIT9	BIT8	BIT7	BIT6	BIT5	BIT4	BIT3	BIT2	BIT1	BIT0	DI0	DI9	DI8	DI7	DI6	DI5	DI4	DI3	DI2	DI1
BIT9	BIT8	BIT7	BIT6	BIT5	BIT4	BIT3	BIT2	BIT1	BIT0													
DI0	DI9	DI8	DI7	DI6	DI5	DI4	DI3	DI2	DI1													
F9-21	Output terminal status upon 3rd fault	<p>It displays the status of all output terminals when the latest fault occurs.</p> <p>The sequence is as follows:</p> <table border="1" style="margin-left: auto; margin-right: auto;"> <tr> <td>BIT4</td><td>BIT3</td><td>BIT2</td><td>BIT1</td><td>BIT0</td> </tr> <tr> <td>DO2</td><td>DO1</td><td>REL2</td><td>REL1</td><td>FMP</td> </tr> </table> <p>If an output terminal is ON, the setting is 1. If the output terminal is OFF, the setting is 0. The value is the equivalent decimal number converted from the DI statuses.</p>	BIT4	BIT3	BIT2	BIT1	BIT0	DO2	DO1	REL2	REL1	FMP										
BIT4	BIT3	BIT2	BIT1	BIT0																		
DO2	DO1	REL2	REL1	FMP																		
F9-22	AC drive status upon 3rd fault	Reserved																				
F9-23	Power-on time upon 3rd fault	It displays the present power-on time when the latest fault occurs.																				
F9-24	Running time upon 3rd fault	It displays the present running time when the latest fault occurs.																				
F9-27	Frequency upon 2nd fault	Same as F9-17–F9-24.																				
F9-28	Current upon 2nd fault																					
F9-29	Bus voltage upon 2nd fault																					
F9-30	DI status upon 2nd fault																					
F9-31	Output terminal status upon 2nd fault																					
F9-32	Frequency upon 2nd fault																					
F9-33	Current upon 2nd fault																					
F9-34	Bus voltage upon 2nd fault																					
F9-37	DI status upon 1st fault	Same as F9-17–F9-24.																				
F9-38	Output terminal status upon 1st fault																					
F9-39	Frequency upon 1st fault																					
F9-40	Current upon 1st fault																					
F9-41	Bus voltage upon 3rd fault																					
F9-42	DI status upon 1st fault																					
F9-43	Output terminal status upon 1st fault																					
F9-44	Frequency upon 1st fault																					

Function Code	Parameter Name	Setting Range	Default
F9-47	Fault protection action selection 1	Unit's digit (Motor overload, Err11)	00000
		0: Coast to stop 1: Stop according to the stop mode 2: Continue to run	
		Ten's digit (Power input phase loss, Err12)	
		Same as unit's digit	
		Hundred's digit (Power output phase loss, Err13)	
		Same as unit's digit	
		Thousand's digit (External equipment fault, Err15)	
		Same as unit's digit	
		Ten thousand's digit (Communication fault, Err16)	
		Same as unit's digit	
F9-48	Fault protection action selection 2	Unit's digit (Encoder fault, Err20)	00000
		0: Coast to stop 1: Switch over to V/F control, stop according to the stop mode 2: Switch over to V/F control, continue to run	
		Ten's digit (EEPROM read-write fault, Err21)	
		0: Coast to stop 1: Stop according to the stop mode	
		Hundred's digit: reserved	
		Thousand's digit (Motor overheat, Err25)	
		Same as unit's digit in F9-47	
		Ten thousand's digit (Accumulative running time reached)	
		Same as unit's digit in F9-47	

Function Code	Parameter Name	Setting Range	Default
F9-49	Fault protection action selection 3	Unit's digit (User-defined fault 1, Err27)	00000
		Same as unit's digit in F9-47	
		Ten's digit (User-defined fault 2, Err28)	
		Same as unit's digit in F9-47	
		Hundred's digit (Accumulative power-on time reached, Err29)	
		Same as unit's digit in F9-47	
		Thousand's digit (Load becoming 0, Err30)	
		0: Coast to stop 1: Stop according to the stop mode 2: Continue to run at 7% of rated motor frequency and resume to the set frequency if the load recovers	
		Ten thousand's digit (PID feedback lost during running, Err31)	
		Same as unit's digit in F9-47	
F9-50	Fault protection action selection 4	Unit's digit (Too large speed deviation, Err42)	00000
		Same as unit's digit in F9-47	
		Ten's digit (Motor over-speed, Err43)	
		Same as unit's digit in F9-47	
		Hundred's digit (Initial position fault, Err51)	
		Same as unit's digit in F9-47	
		Thousand's digit (Speed feedback fault, Err52)	
		Same as unit's digit in F9-47	
		Ten thousand's digit: Reserved	

If "Coast to stop" is selected, the AC drive displays Err** and directly stops.

- If "Stop according to the stop mode" is selected, the AC drive displays A** and stops according to the stop mode. After stop, the AC drive displays Err**.
- If "Continue to run" is selected, the AC drive continues to run and displays A**. The running frequency is set in F9-54.

Function Code	Parameter Name	Setting Range	Default
F9-54	Frequency selection for continuing to run upon fault	0: Current running frequency 1: Set frequency 2: Frequency upper limit 3: Frequency lower limit 4: Backup frequency upon abnormality	0
F9-55	Backup frequency upon abnormality	0.0%–100.0% (maximum frequency)	100.0%

If a fault occurs during the running of the AC drive and the handling of fault is set to "Continue to run", the AC drive displays A** and continues to run at the frequency set in F9-54.

The setting of F9-55 is a percentage relative to the maximum frequency.

Function Code	Parameter Name	Setting Range	Default
F9-56	Type of motor temperature sensor	0: No temperature sensor 1: PT100 2: PT1000	0
F9-57	Motor overheat protection threshold	0–200° C	110° C
F9-58	Motor overheat warning threshold	0–200° C	90° C

The signal of the motor temperature sensor needs to be connected to the optional I/O extension card. AI3 on the extension card can be used for the temperature signal input. The motor temperature sensor is connected to AI3 and PGND of the extension card. The AI3 terminal of the MD380 supports both PT100 and PT1000. Set the sensor type correctly during the use. You can view the motor temperature via U0-34.

If the motor temperature exceeds the value set in F9-57, the AC drive reports an alarm and acts according to the selected fault protection action.

If the motor temperature exceeds the value set in F9-58, the DO terminal on the AC drive allocated with function 39 (Motor overheat warning) becomes ON.

Function Code	Parameter Name	Setting Range	Default
F9-59	Action selection at instantaneous power failure	0: Invalid 1: Decelerate 2: Decelerate to stop	0
F9-60	Action pause judging voltage at instantaneous power failure	80.0%–100.0%	90.0%
F9-61	Voltage rally judging time at instantaneous power failure	0.00–100.00s	0.50s
F9-62	Action judging voltage at instantaneous power failure	60.0%–100.0% (standard bus voltage)	80.0%

Upon instantaneous power failure or sudden voltage dip, the DC bus voltage of the AC drive reduces. This function enables the AC drive to compensate the DC bus voltage reduction with the load feedback energy by reducing the output frequency so as to keep the AC drive running continuously.

- If F9-59 = 1, upon instantaneous power failure or sudden voltage dip, the AC drive decelerates. Once the bus voltage resumes to normal, the AC drive accelerates to the set frequency. If the bus voltage remains normal for the time exceeding the value set in F9-61, it is considered that the bus voltage resumes to normal.
- If F9-59 = 2, upon instantaneous power failure or sudden voltage dip, the AC drive decelerates to stop.

Figure 6-26 AC drive action diagram upon instantaneous power failure

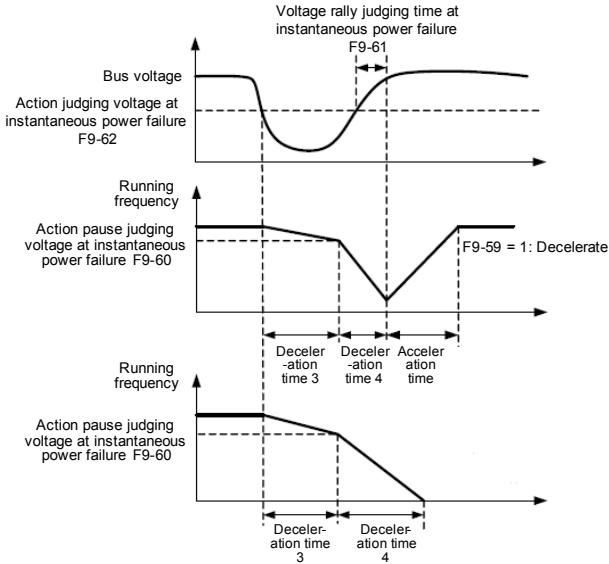

Function Code	Parameter Name	Setting Range	Default
F9-63	Protection upon load becoming 0	0: Disabled 1: Enabled	0
F9-64	Detection level of load becoming 0	0.0%–100.0% (rated motor current)	10.0%
F9-65	Detection time of load becoming 0	0.0–60.0s	1.0s

If protection upon load becoming 0 is enabled, when the output current of the AC drive is lower than the detection level (F9-64) and the lasting time exceeds the detection time (F9-65), the output frequency of the AC drive automatically declines to 7% of the rated frequency. During the protection, the AC drive automatically accelerates to the set frequency if the load resumes to normal.

Function Code	Parameter Name	Setting Range	Default
F9-67	Over-speed detection value	0.0%–50.0% (maximum frequency)	20.0%
F9-68	Over-speed detection time	0.0–60.0s	1.0s

This function is valid only when the AC drive runs in the CLVC mode.

If the actual motor rotational speed detected by the AC drive exceeds the maximum frequency and the excessive value is greater than the value of F9-67 and the lasting time exceeds the value of F9-68, the AC drive reports Err43 and acts according to the selected fault protection action.

If the over-speed detection time is 0.0s, the over-speed detection function is disabled.

Function Code	Parameter Name	Setting Range	Default
F9-69	Detection value of too large speed deviation	0.0%–50.0% (maximum frequency)	20.0%
F9-70	Detection time of too large speed deviation	0.0–60.0s	5.0s

This function is valid only when the AC drive runs in the CLVC mode.

If the AC drive detects the deviation between the actual motor rotational speed detected by the AC drive and the set frequency is greater than the value of F9-69 and the lasting time exceeds the value of F9-70, the AC drive reports Err42 and according to the selected fault protection action.

If F9-70 (Detection time of too large speed deviation) is 0.0s, this function is disabled.

Group FA: Process Control PID Function

PID control is a general process control method. By performing proportional, integral and differential operations on the difference between the feedback signal and the target signal, it adjusts the output frequency and constitutes a feedback system to stabilize the controlled counter around the target value.

It is applied to process control such as flow control, pressure control and temperature control. The following figure shows the principle block diagram of PID control.

Figure 6-27 Principle block diagram of PID control

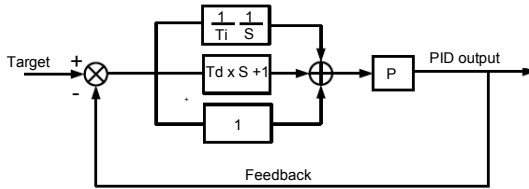

Function Code	Parameter Name	Setting Range	Default
FA-00	PID setting source	0: FA-01 1: AI1 2: AI2 3: AI3 4: Pulse setting (DI5) 5: Communication setting 6: Multi-reference	0
FA-01	PID digital setting	0.0%–100.0%	50.0%

FA-00 is used to select the channel of target process PID setting. The PID setting is a relative value and ranges from 0.0% to 100.0%. The PID feedback is also a relative value. The purpose of PID control is to make the PID setting and PID feedback equal.

Function Code	Parameter Name	Setting Range	Default
FA-02	PID feedback source	0: AI1 1: AI2 2: AI3 3: AI1 – AI2 4: Pulse setting (DI5) 5: Communication setting 6: AI1 + AI2 7: MAX (AI1 , AI2) 8: MIN (AI1 , AI2)	0

This parameter is used to select the feedback signal channel of process PID.

The PID feedback is a relative value and ranges from 0.0% to 100.0%.

Function Code	Parameter Name	Setting Range	Default
FA-03	PID action direction	0: Forward action 1: Reverse action	0

- 0: Forward action

When the feedback value is smaller than the PID setting, the AC drive's output frequency rises. For example, the winding tension control requires forward PID action.

- 1: Reverse action

When the feedback value is smaller than the PID setting, the AC drive's output frequency reduces. For example, the unwinding tension control requires reverse PID action.

Note that this function is influenced by the DI function 35 "Reverse PID action direction".

Function Code	Parameter Name	Setting Range	Default
FA-04	PID setting feedback range	0–65535	1000

This parameter is a non-dimensional unit. It is used for PID setting display (U0-15) and PID feedback display (U0-16).

Relative value 100% of PID setting feedback corresponds to the value of FA-04. If FA-04 is set to 2000 and PID setting is 100.0%, the PID setting display (U0-15) is 2000.

Function Code	Parameter Name	Setting Range	Default
FA-05	Proportional gain Kp1	0.0–100.0	20.0
FA-06	Integral time Ti1	0.01–10.00s	2.00s
FA-07	Differential time Td1	0.00–10.000	0.000s

- FA-05 (Proportional gain Kp1)
 It decides the regulating intensity of the PID regulator. The higher the Kp1 is, the larger the regulating intensity is. The value 100.0 indicates when the deviation between PID feedback and PID setting is 100.0%, the adjustment amplitude of the PID regulator on the output frequency reference is the maximum frequency.
- FA-06 (Integral time Ti1)
 It decides the integral regulating intensity. The shorter the integral time is, the larger the regulating intensity is. When the deviation between PID feedback and PID setting is 100.0%, the integral regulator performs continuous adjustment for the time set in FA-06. Then the adjustment amplitude reaches the maximum frequency.
- FA-07 (Differential time Td1)
 It decides the regulating intensity of the PID regulator on the deviation change. The longer the differential time is, the larger the regulating intensity is. Differential time is the time within which the feedback value change reaches 100.0%, and then the adjustment amplitude reaches the maximum frequency.

Function Code	Parameter Name	Setting Range	Default
FA-08	Cut-off frequency of PID reverse rotation	0.00 to maximum frequency	2.00 Hz

In some situations, only when the PID output frequency is a negative value (AC drive reverse rotation), PID setting and PID feedback can be equal. However, too high reverse rotation frequency is prohibited in some applications, and FA-08 is used to determine the reverse rotation frequency upper limit.

Function Code	Parameter Name	Setting Range	Default
FA-09	PID deviation limit	0.0%–100.0%	0.0%

If the deviation between PID feedback and PID setting is smaller than the value of FA-09, PID control stops. The small deviation between PID feedback and PID setting will make the output frequency stabilize, effective for some closed-loop control applications.

Function Code	Parameter Name	Setting Range	Default
FA-10	PID differential limit	0.00%–100.00%	0.10%

It is used to set the PID differential output range. In PID control, the differential operation may easily cause system oscillation. Thus, the PID differential regulation is restricted to a small range.

Function Code	Parameter Name	Setting Range	Default
FA-11	PID setting change time	0.00–650.00s	0.00s

The PID setting change time indicates the time required for PID setting changing from 0.0% to 100.0%. The PID setting changes linearly according to the change time, reducing the impact caused by sudden setting change on the system.

Function Code	Parameter Name	Setting Range	Default
FA-12	PID feedback filter time	0.00–60.00s	0.00s
FA-13	PID output filter time	0.00–60.00s	0.00s

FA-12 is used to filter the PID feedback, helping to reduce interference on the feedback but slowing the response of the process closed-loop system.

FA-13 is used to filter the PID output frequency, helping to weaken sudden change of the AC drive output frequency but slowing the response of the process closed-loop system.

Function Code	Parameter Name	Setting Range	Default
FA-15	Proportional gain Kp2	0.0–100.0	20.0
FA-16	Integral time Ti2	0.01–10.00s	2.00s
FA-17	Differential time Td2	0.000–10.000s	0.000s
FA-18	PID parameter switchover condition	0: No switchover 1: Switchover via DI 2: Automatic switchover based on deviation	0
FA-19	PID parameter switchover deviation 1	0.0% to FA-20	20.0%
FA-20	PID parameter switchover deviation 2	FA-19 to 100.0%	80.0%

In some applications, PID parameters switchover is required when one group of PID parameters cannot satisfy the requirement of the whole running process.

These parameters are used for switchover between two groups of PID parameters. Regulator parameters FA-15 to FA-17 are set in the same way as FA-05 to FA-07.

The switchover can be implemented either via a DI terminal or automatically implemented based on the deviation.

If you select switchover via a DI terminal, the DI must be allocated with function 43 "PID parameter switchover". If the DI is OFF, group 1 (FA-05 to FA-07) is selected. If the DI is ON, group 2 (FA-15 to FA-17) is selected.

If you select automatic switchover, when the absolute value of the deviation between PID feedback and PID setting is smaller than the value of FA-19, group 1 is selected. When the absolute value of the deviation between PID feedback and PID setting is higher than the value of FA-20, group 2 is selected. When the deviation is between FA-19 and FA-20, the PID parameters are the linear interpolated value of the two groups of parameter values.

Figure 6-28 PID parameters switchover

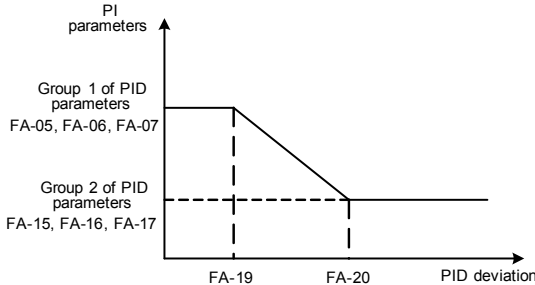

Function Code	Parameter Name	Setting Range	Default
FA-21	PID initial value	0.0%–100.0%	0.0%
FA-22	PID initial value holding time	0.00–650.00s	0.00s

When the AC drive starts up, the PID starts closed-loop algorithm only after the PID output is fixed to the PID initial value (FA-21) and lasts the time set in FA-22.

Figure 6-29 PID initial value function

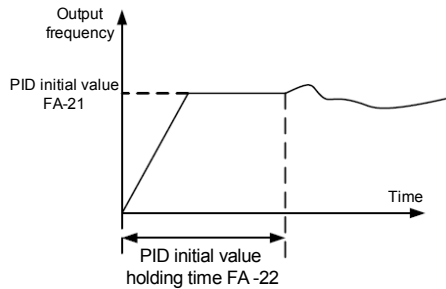

Function Code	Parameter Name	Setting Range	Default
FA-23	Maximum deviation between two PID outputs in forward direction	0.00%–100.00%	1.00%
FA-24	Maximum deviation between two PID outputs in reverse direction	0.00%–100.00%	1.00%

This function is used to limit the deviation between two PID outputs (2 ms per PID output) to suppress the rapid change of PID output and stabilize the running of the AC drive.

FA-23 and FA-24 respectively correspond to the maximum absolute value of the output deviation in forward direction and in reverse direction.

Function Code	Parameter Name	Setting Range	Default
FA-25	PID integral property	Unit's digit (Integral separated)	00
		0: Invalid 1: Valid	
		Ten's digit (Whether to stop integral operation when the output reaches the limit)	
		0: Continue integral operation 1: Stop integral operation	

- Integral separated

If it is set to valid, , the PID integral operation stops when the DI allocated with function 38 "PID integral pause" is ON In this case, only proportional and differential operations take effect.

If it is set to invalid, integral separated remains invalid no matter whether the DI allocated with function 38 "PID integral pause" is ON or not.

- Whether to stop integral operation when the output reaches the limit

If "Stop integral operation" is selected, the PID integral operation stops, which may help to reduce the PID overshoot.

Function Code	Parameter Name	Setting Range	Default
FA-26	Detection value of PID feedback loss	0.0%: Not judging feedback loss 0.1%–100.0%	0.0%
FA-27	Detection time of PID feedback loss	0.0–20.0s	0.0s

These parameters are used to judge whether PID feedback is lost.

If the PID feedback is smaller than the value of FA-26 and the lasting time exceeds the value of FA-27, the AC drive reports Err31 and acts according to the selected fault protection action.

Function Code	Parameter Name	Setting Range	Default
FA-28	PID operation at stop	0: No PID operation at stop 1: PID operation at stop	0

It is used to select whether to continue PID operation in the state of stop. Generally, the PID operation stops when the AC drive stops.

Group FB: Swing Frequency, Fixed Length and Count

The swing frequency function is applied to the textile and chemical fiber fields and the applications where traversing and winding functions are required.

The swing frequency function indicates that the output frequency of the AC drive swings up and down with the set frequency as the center. The trace of running frequency at the time axis is shown in the following figure.

The swing amplitude is set in FB-00 and FB-01. When FB-01 is set to 0, the swing amplitude is 0 and the swing frequency does not take effect.

Figure 6-30 Swing frequency control

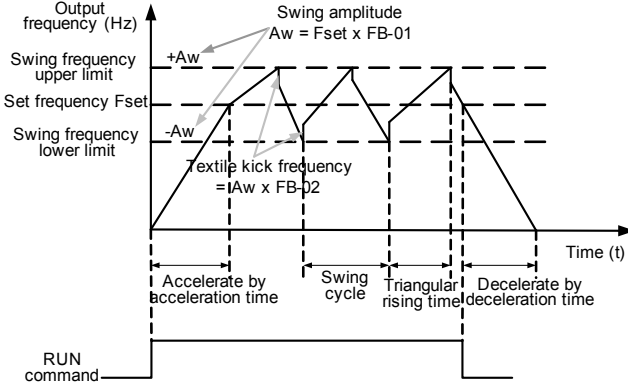

Function Code	Parameter Name	Setting Range	Default
FB-00	Swing frequency setting mode	0: Relative to the central frequency 1: Relative to the maximum frequency	0

This parameter is used to select the base value of the swing amplitude.

- 0: Relative to the central frequency (F0-07 frequency source selection)
It is variable swing amplitude system. The swing amplitude varies with the central frequency (set frequency).
- 1: Relative to the maximum frequency (F0-10 maximum output frequency)
It is fixed swing amplitude system. The swing amplitude is fixed.

Function Code	Parameter Name	Setting Range	Default
FB-01	Swing frequency amplitude	0.0%–100.0%	0.0%
FB-02	Jump frequency amplitude	0.0%–50.0%	0.0%

This parameter is used to determine the swing amplitude and jump frequency amplitude. The swing frequency is limited by the frequency upper limit and frequency lower limit.

- If relative to the central frequency (FB-00 = 0), the actual swing amplitude AW is the calculation result of F0-07 (Frequency source selection) multiplied by FB-01.
- If relative to the maximum frequency (FB-00 = 1), the actual swing amplitude AW is the calculation result of F0-10 (Maximum frequency) multiplied by FB-01.

Jump frequency = Swing amplitude AW x FB-02 (Jump frequency amplitude).

- If relative to the central frequency (FB-00 = 0), the jump frequency is a variable value.
- If relative to the maximum frequency (FB-00 = 1), the jump frequency is a fixed value.

The swing frequency is limited by the frequency upper limit and frequency lower limit.

Function Code	Parameter Name	Setting Range	Default
FB-03	Swing frequency cycle	0.0–3000.0s	10.0s
FB-04	Triangular wave rising time coefficient	0.0%–100.0%	50.0%

FB-03 specifies the time of a complete swing frequency cycle.

FB-04 specifies the time percentage of triangular wave rising time to FB-03 (Swing frequency cycle).

- Triangular wave rising time = FB-03 (Swing frequency cycle) x FB-04 (Triangular wave rising time coefficient, unit: s)
- Triangular wave falling time = FB-03 (Swing frequency cycle) x (1 – FB-04 Triangular wave rising time coefficient ,unit: s)

Function Code	Parameter Name	Setting Range	Default
FB-05	Set length	0–65535 m	1000 m
FB-06	Actual length	0–65535 m	0 m
FB-07	Number of pulses per meter	0.1–6553.5	100.0

The preceding parameters are used for fixed length control.

The length information is collected by DI terminals. FB-06 (Actual length) is calculated by dividing the number of pulses collected by the DI terminal by FB-07 (Number of pulses each meter).

When the actual length FB-06 exceeds the set length in FB-05, the DO terminal allocated with function 10 (Length reached) becomes ON.

During the fixed length control, the length reset operation can be performed via the DI terminal allocated with function 28. For details, see the descriptions of F4-00 to F4-09.

Allocate corresponding DI terminal with function 27 (Length count input) in applications. If the pulse frequency is high, DI5 must be used.

Function Code	Parameter Name	Setting Range	Default
FB-08	Set count value	1–65535	1000
FB-09	Designated count value	1–65535	1000

The count value needs to be collected by DI terminal. Allocate the corresponding DI terminal with function 25 (Counter input) in applications. If the pulse frequency is high, DI5 must be used.

When the count value reaches the set count value (FB-08), the DO terminal allocated with function 8 (Set count value reached) becomes ON. Then the counter stops counting.

When the counting value reaches the designated counting value (FB-09), the DO terminal allocated with function 9 (Designated count value reached) becomes ON. Then the counter continues to count until the set count value is reached.

FB-09 should be equal to or smaller than FB-08.

Figure 6-31 Reaching the set count value and designated count value

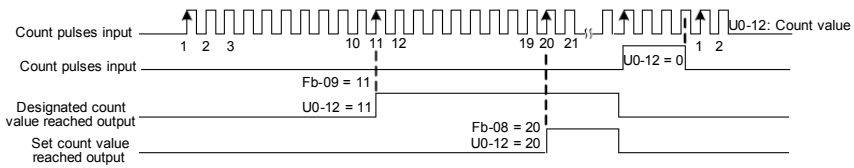

Group FC: Multi-Reference and Simple PLC Function

The MD380 multi-reference has many functions. Besides multi-speed, it can be used as the setting source of the V/F separated voltage source and setting source of process PID. In addition, the multi-reference is relative value.

The simple PLC function is different from the MD380 user programmable function. Simple PLC can only complete simple combination of multi-reference, while the user programmable function is more practical. For details, see the descriptions of group A7.

Function Code	Parameter Name	Setting Range	Default
FC-00	Reference 0	-100.0%~100.0%	0.0%
FC-01	Reference 1	-100.0%~100.0%	0.0%
FC-02	Reference 2	-100.0%~100.0%	0.0%
FC-03	Reference 3	-100.0%~100.0%	0.0%
FC-04	Reference 4	-100.0%~100.0%	0.0%
FC-05	Reference 5	-100.0%~100.0%	0.0%
FC-06	Reference 6	-100.0%~100.0%	0.0%
FC-07	Reference 7	-100.0%~100.0%	0.0%
FC-08	Reference 8	-100.0%~100.0%	0.0%
FC-09	Reference 9	-100.0%~100.0%	0.0%
FC-10	Reference 10	-100.0%~100.0%	0.0%
FC-11	Reference 11	-100.0%~100.0%	0.0%
FC-12	Reference 12	-100.0%~100.0%	0.0%
FC-13	Reference 13	-100.0%~100.0%	0.0%
FC-14	Reference 14	-100.0%~100.0%	0.0%
FC-15	Reference 15	-100.0%~100.0%	0.0%

Multi-reference can be the setting source of frequency, V/F separated voltage and process PID. The multi-reference is relative value and ranges from -100.0% to 100.0%.

As frequency source, it is a percentage relative to the maximum frequency. As V/F separated voltage source, it is a percentage relative to the rated motor voltage. As process PID setting source, it does not require conversion.

Multi-reference can be switched over based on different states of DI terminals. For details, see the descriptions of group F4.

Function Code	Parameter Name	Setting Range	Default
FC-16	Simple PLC running mode	0: Stop after the AC drive runs one cycle 1: Keep final values after the AC drive runs one cycle 2: Repeat after the AC drive runs one cycle	0

- 0: Stop after the AC drive runs one cycle
The AC drive stops after running one cycle, and will not start up until receiving another command.
- 1: Keep final values after the AC drive runs one cycle
The AC drive keeps the final running frequency and direction after running one cycle.
- 2: Repeat after the AC drive runs one cycle
The AC drive automatically starts another cycle after running one cycle, and will not stop until receiving the stop command.

Simple PLC can be either the frequency source or V/F separated voltage source.

When simple PLC is used as the frequency source, whether parameter values of FC-00 to FC-15 are positive or negative determines the running direction. If the parameter values are negative, it indicates that the AC drive runs in reverse direction.

Figure 6-32 Simple PLC when used as frequency source

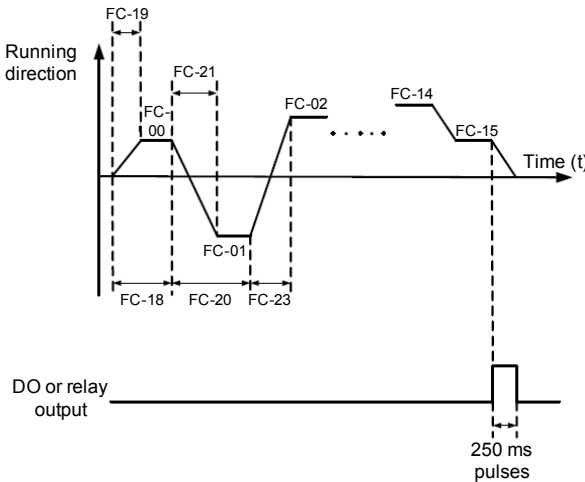

Function Code	Parameter Name	Setting Range	Default
FC-17	Simple PLC retentive selection	Unit's digit (Retentive upon power failure)	00
		0: No 1: Yes	
		Ten's digit (Retentive upon stop)	
		0: No 1: Yes	

PLC retentive upon power failure indicates that the AC drive memorizes the PLC running moment and running frequency before power failure and will continue to run from the memorized moment after it is powered on again. If the unit's digit is set to 0, the AC drive restarts the PLC process after it is powered on again.

PLC retentive upon stop indicates that the AC drive records the PLC running moment and running frequency upon stop and will continue to run from the recorded moment after it starts up again. If the ten's digit is set to 0, the AC drive restarts the PLC process after it starts up again.

Function Code	Parameter Name	Setting Range	Default
FC-18	Running time of simple PLC reference 0	0.0-6553.5s (h)	0.0s (h)
FC-19	Acceleration/deceleration time of simple PLC reference 0	0-3	0
FC-20	Running time of simple PLC reference 1	0.0-6553.5s (h)	0.0s (h)
FC-21	Acceleration/deceleration time of simple PLC reference 1	0-3	0
FC-22	Running time of simple PLC reference 2	0.0-6553.5s (h)	0.0s (h)
FC-23	Acceleration/deceleration time of simple PLC reference 2	0-3	0
FC-24	Running time of simple PLC reference 3	0.0-6553.5s (h)	0.0s (h)
FC-25	Acceleration/deceleration time of simple PLC reference 3	0-3	0
FC-26	Running time of simple PLC reference 4	0.0-6553.5s (h)	0.0s (h)
FC-27	Acceleration/deceleration time of simple PLC reference 4	0-3	0
FC-28	Running time of simple PLC reference 5	0.0-6553.5s (h)	0.0s (h)
FC-29	Acceleration/deceleration time of simple PLC reference 5	0-3	0
FC-30	Running time of simple PLC reference 6	0.0-6553.5s (h)	0.0s (h)
FC-31	Acceleration/deceleration time of simple PLC reference 6	0-3	0
FC-32	Running time of simple PLC reference 7	0.0-6553.5s (h)	0.0s (h)
FC-33	Acceleration/deceleration time of simple PLC reference 7	0-3	0

Function Code	Parameter Name	Setting Range	Default
FC-34	Running time of simple PLC reference 8	0.0–6553.5s (h)	0.0s (h)
FC-35	Acceleration/deceleration time of simple PLC reference 8	0–3	0
FC-36	Running time of simple PLC reference 9	0.0–6553.5s (h)	0.0s (h)
FC-37	Acceleration/deceleration time of simple PLC reference 9	0–3	0
FC-38	Running time of simple PLC reference 10	0.0–6553.5s (h)	0.0s (h)
FC-39	Acceleration/deceleration time of simple PLC reference 10	0–3	0
FC-40	Running time of simple PLC reference 11	0.0–6553.5s (h)	0.0s (h)
FC-41	Acceleration/deceleration time of simple PLC reference 11	0–3	0
FC-42	Running time of simple PLC reference 12	0.0–6553.5s (h)	0.0s (h)
FC-43	Acceleration/deceleration time of simple PLC reference 12	0–3	0
FC-44	Running time of simple PLC reference 13	0.0–6553.5s (h)	0.0s (h)
FC-45	Acceleration/deceleration time of simple PLC reference 13	0–3	0
FC-46	Running time of simple PLC reference 14	0.0–6553.5s (h)	0.0s (h)
FC-47	Acceleration/deceleration time of simple PLC reference 14	0–3	0
FC-48	Running time of simple PLC reference 15	0.0–6553.5s (h)	0.0s (h)
FC-49	Acceleration/deceleration time of simple PLC reference 15	0–3	0
FC-50	Time unit of simple PLC running	0: s (second) 1: h (hour)	0

Function Code	Parameter Name	Setting Range	Default
FC-51	Reference 0 source	0: Set by FC-00 1: AI1 2: AI2 3: AI3 4: Pulse setting 5: PID 6: Set by preset frequency (F0-08), modified via terminal UP/DOWN	0

It determines the setting channel of reference 0. You can perform convenient switchover between the setting channels. When multi-reference or simple PLC is used as frequency source, the switchover between two frequency sources can be realized easily.

Group FD: User-defined Parameters

Group FE: User-Defined Function Codes

Function Code	Parameter Name	Setting Range	Default
FE-00	User-defined function code 0	F0-00 to FP-xx, A0-00 to Ax-xx, U0-xx	F0-00
FE-01	User-defined function code 1	Same as FE-00	F0-02
FE-02	User-defined function code 2	Same as FE-00	F0-03
FE-03	User-defined function code 3	Same as FE-00	F0-07
FE-04	User-defined function code 4	Same as FE-00	F0-08
FE-05	User-defined function code 5	Same as FE-00	F0-17
FE-06	User-defined function code 6	Same as FE-00	F0-18
FE-07	User-defined function code 7	Same as FE-00	F3-00
FE-08	User-defined function code 8	Same as FE-00	F3-01
FE-09	User-defined function code 9	Same as FE-00	F4-00
FE-10	User-defined function code 10	Same as FE-00	F4-01
FE-11	User-defined function code 11	Same as FE-00	F4-02
FE-12	User-defined function code 12	Same as FE-00	F5-04
FE-13	User-defined function code 13	Same as FE-00	F5-07
FE-14	User-defined function code 14	Same as FE-00	F6-00
FE-15	User-defined function code 15	Same as FE-00	F6-10
FE-16	User-defined function code 16	Same as FE-00	F0-00
FE-17	User-defined function code 17	Same as FE-00	F0-00
FE-18	User-defined function code 18	Same as FE-00	F0-00
FE-19	User-defined function code 19	Same as FE-00	F0-00
FE-20	User-defined function code 20	Same as FE-00	F0-00
FE-21	User-defined function code 21	Same as FE-00	F0-00
FE-22	User-defined function code 22	Same as FE-00	F0-00
FE-23	User-defined function code 23	Same as FE-00	F0-00
FE-24	User-defined function code 24	Same as FE-00	F0-00
FE-25	User-defined function code 25	Same as FE-00	F0-00
FE-26	User-defined function code 26	Same as FE-00	F0-00
FE-27	User-defined function code 27	Same as FE-00	F0-00
FE-28	User-defined function code 28	Same as FE-00	F0-00
FE-29	User-defined function code 29	Same as FE-00	F0-00

FE is user-defined parameter group. You can select the required parameters from all MD380 functions codes and add them into this group, convenient for view and modification.

Group FE provides a maximum of 30 user-defined parameters. If "FE-00" is displayed, it indicates that group FE is null. After you enter user-defined function code mode, the displayed parameters are defined by FE-00 to FE-31 and the sequence is consistent with that in group FE.

Group FP: User Password

Function Code	Parameter Name	Setting Range	Default
FP-00	User password	0-65535	0

If it is set to any non-zero number, the password protection function is enabled. After a password has been set and taken effect, you must enter the correct password in order to enter the menu. If the entered password is incorrect you cannot view or modify parameters.

If FP-00 is set to 00000, the previously set user password is cleared, and the password protection function is disabled.

Function Code	Parameter Name	Setting Range	Default
FP-01	Restore default settings	0: No operation 1: Restore factory settings except motor parameters 2: Clear records 4: Restore user backup parameters 501: Back up current user parameters	0

- 1: Restore default settings except motor parameters

If FP-01 is set to 1, most function codes are restored to the default settings except motor parameters, frequency reference resolution (F0-22), fault records, accumulative running time (F7-09), accumulative power-on time (F7-13) and accumulative power consumption (F7-14).

- 2: Clear records

If FP-01 is set to 2, the fault records, accumulative running time (F7-09), accumulative power-on time (F7-13) and accumulative power consumption (F7-14) are cleared.

- 501: Back up current user parameters

If FP-01 is set to 501, the current parameter settings are backed up, helping you to restore the setting if incorrect parameter setting is performed.

- 4: Restore user backup parameters

If FP-01 is set to 4, the previous backup user parameters are restored.

Function Code	Parameter Name	Setting Range	Default
FP-02	AC drive parameter display property	Unit's digit (Group U display selection)	11
		0: Not display 1: Display	
		Ten's digit (Group A display selection)	
		0: Not display 1: Display	
FP-03	Individualized parameter display property	Unit's digit (User-defined parameter display selection)	00
		0: Not display 1: Display	
		Ten's digit (User-modified parameter display selection)	
		0: Not display 1: Display	

The setting of parameter display mode aims to facilitate you to view different types of parameters based on actual requirements. The MD380 provides the following three parameter display modes.

Table 6-9 Three parameter display modes provided by MD380

Name	Description
AC drive parameter display	Display function codes of the AC drive in sequence of F0 to FF, A0 to AF and U0 to UF.
User-defined parameter display	Display a maximum of 32 user-defined parameters included in group FE.
User-modified parameter display	Display the parameters that are modified.

If one digit of FP-03 is set to 1, you can switch over to different parameter display modes by pressing key **QUICK**. By default, the AC drive parameter display mode is used.

The display codes of different parameter types are shown in the following table.

Table 6-10 Display codes of different parameter types

Parameter Type	Display Code
AC drive parameter	- b A S E
User-defined parameter	- U S E r
User-modified parameter	- - [- -

The MD380 provides display of two types of individualized parameters: user-defined parameters and user-modified parameters.

- You-defined parameters are included in group FE. You can add a maximum of 32 parameters, convenient for commissioning.

In user-defined parameter mode, symbol "u" is added before the function code. For example, F1-00 is displayed as uF1-00.

- You-modified parameters are grouped together, convenient for on-site troubleshooting. In you-modified parameter mode, symbol "c" is added before the function code. For example, F1-00 is displayed as cF1-00.

Function Code	Name	Setting Range	Default
FP-04	Parameter modification property	0: Modifiable 1: Not modifiable	0

It is used to set whether the parameters are modifiable to avoid mal-function. If it is set to 0, all parameters are modifiable. If it is set to 1, all parameters can only be viewed.

Group A0: Torque Control and Restricting Parameters

Function Code	Parameter Name	Setting Range	Default
A0-00	Speed/Torque control selection	0: Speed control 1: Torque control	0

It is used to select the AC drive's control mode: speed control or torque control.

The MD380 provides DI terminals with two torque related functions, function 29 (Torque control prohibited) and function 46 (Speed control/Torque control switchover). The two DI terminals need to be used together with A0-00 to implement speed control/torque control switchover.

If the DI terminal allocated with function 46 (Speed control/Torque control switchover) is OFF, the control mode is determined by A0-00. If the DI terminal allocated with function 46 is ON, the control mode is reverse to the value of A0-00.

However, if the DI terminal with function 29 (Torque control prohibited) is ON, the AC drive is fixed to run in the speed control mode.

Function Code	Parameter Name	Setting Range	Default
A0-01	Torque setting source in torque control	0: Digital setting (A0-03) 1: AI1 2: AI2 3: AI3 4: Pulse setting (DI5) 5: Communication setting 6: MIN (AI1, AI2) 7: MAX (AI1, AI2)	0
A0-03	Torque digital setting in torque control	-200.0%~+200.0%	150.0%

A0-01 is used to set the torque setting source. There are a total of eight torque setting sources.

The torque setting is a relative value. 100.0% corresponds to the AC drive's rated torque. The setting range is -200.0% to 200.0%, indicating the AC drive's maximum torque is twice of the AC drive's rated torque.

If the torque setting is positive, the AC drive rotates in forward direction. If the torque setting is negative, the AC drive rotates in reverse direction.

- 1: Digital setting (A0-03)

The target torque directly uses the value set in A0-03.

- 2: AI1
- 3: AI2
- 4: AI3

The target torque is decided by analog input. The MD380 control board provides two AI terminals (AI1, AI2). Another AI terminal (AI3) is provided by the I/O extension card. AI1 is 0–10 V voltage input, AI2 is 0–10 V voltage input or 4–20 mA current input decided by jumper J8 on the control board, and AI3 is -10 V to +10 V voltage input.

The MD380 provides five curves indicating the mapping relationship between the input voltage of AI1, AI2 and AI3 and the target frequency, three of which are linear (point-point) correspondence and two of which are four-point correspondence curves. You can set the curves by using function codes F4-13 to F4-27 and function codes in group A6, and select curves for AI1, AI2 and AI3 in F4-33.

When AI is used as frequency setting source, the corresponding value 100% of voltage/current input corresponds to the value of A0-03.

- 5: Pulse setting (DI5)

The target torque is set by DI5 (high-speed pulse). The pulse setting signal specification is 9–30 V (voltage range) and 0–100 kHz (frequency range). The pulse can only be input via DI5. The relationship (which is a two-point line) between DI5 input pulse frequency and the corresponding value is set in F4-28 to F4-31. The corresponding value 100.0% of pulse input corresponds to the value of A0-03.

- 5: Communication setting

The target torque is set by means of communication.

If the AC drive is a slave in point-point communication and receives data as torque source, data transmitted by the master is used as the setting value. For details, see the description of group A8.

If PROFIBUS-DP communication is valid and PZD1 is used for torque setting, data transmitted by PDZ1 is directly used as the torque source. The data format is -100.00% to 100.00%. 100% corresponds to the value of A0-03.

In other conditions, data is given by host computer through the communication address 0x1000. The data format is -100.00% to 100.00%. 100% corresponds to the value of A0-03.

The MD380 supports four host computer communication protocols: Modbus,

PROFIBUS-DP, CANopen and CANlink. They cannot be used simultaneously.

If the communication mode is used, a communication card must be installed. The MD380 provides four optional communication cards and you can select one based on actual requirements. If the communication protocol is Modbus, PROFIBUS-DP or CANopen, the corresponding serial communication protocol needs to be selected based on the setting of F0-28.

The CANlink protocol is always valid.

Function Code	Parameter Name	Setting Range	Default
A0-05	Forward maximum frequency in torque control	0.00 Hz to maximum frequency (F0-10)	50.00 Hz
A0-06	Reverse maximum frequency in torque control	0.00 Hz to maximum frequency (F0-10)	50.00 Hz

two parameters are used to set the maximum frequency in forward or reverse rotation in torque control mode.

In torque control, if the load torque is smaller than the motor output torque, the motor's rotational speed will rise continuously. To avoid runaway of the mechanical system, the motor maximum rotating speed must be limited in torque control.

You can implement continuous change of the maximum frequency in torque control dynamically by controlling the frequency upper limit.

Function Code	Parameter Name	Setting Range	Default
A0-07	Acceleration time in torque control	0.00–65000s	0.00s
A0-08	Deceleration time in torque control	0.00–65000s	0.00s

In torque control, the difference between the motor output torque and the load torque determines the speed change rate of the motor and load. The motor rotational speed may change quickly and this will result in noise or too large mechanical stress. The setting of acceleration/deceleration time in torque control makes the motor rotational speed change softly.

However, in applications requiring rapid torque response, set the acceleration/deceleration time in torque control to 0.00s. For example, two AC drives are connected to drive the same load. To balance the load allocation, set one AC drive as master in speed control and the other as slave in torque control. The slave receives the master's output torque as the torque command and must follow the master rapidly. In this case, the acceleration/deceleration time of the slave in torque control is set to 0.0s.

Group A1: Virtual DI (VDI)/Virtual DO (VDO)

Function Code	Parameter Name	Setting Range	Default
A1-00	VDI1 function selection	0–59	0
A1-01	VDI2 function selection	0–59	0
A1-02	VDI3 function selection	0–59	0

Function Code	Parameter Name	Setting Range	Default
A1-03	VDI4 function selection	0-59	0
A1-04	VDI5 function selection	0-59	0

VDI1 to VDI5 have the same functions as DI terminals on the control board and can be used for digital input. For more details, see description of F4-00 to F4-09.

Function Code	Parameter Name	Setting Range	Default
A1-05	VDI state setting mode	Unit's digit (VDI1)	00000
		0: Decided by state of VDOx 1: Decided by A1-06	
		Ten's digit (VDI2)	
		0, 1 (same as VDI1)	
		Hundred's digit (VDI3)	
		0, 1 (same as VDI1)	
		Thousand's digit (VDI4)	
		0, 1 (same as VDI1)	
		Ten thousand's digit (VDI5)	
A1-06	VDI state selection	Unit's digit (VDI1)	00000
		0: Invalid 1: Valid	
		Ten's digit (VDI2)	
		0, 1 (same as VDI1)	
		Hundred's digit (VDI3)	
		0, 1 (same as VDI1)	
		Thousand's digit (VDI4)	
		0, 1 (same as VDI1)	
		Ten thousand's digit (VDI5)	
0, 1 (same as VDI1)			

Different from DI terminals, VDI state can be set in two modes, selected in A1-05:

- Decided by state of VDOx

Whether the state a VDI is valid is determined by the state of the corresponding VDO and VDIx is uniquely bound to VDOx (x is between 1 and 5). For example, to implement the function that the AC drive reports an alarm and stops when the AI1 input exceeds the limit, perform the following setting:

- Allocate VDI1 with function 44 "User-defined fault 1" (A1-00 = 44).
- Set A1-05 to xxx0.
- Allocate VDO1 with function 31 "AI1 input limit exceeded" (A1-11 = 31).

When the AI1 input exceeds the limit, VDO1 becomes ON. At this moment, VDI1 becomes ON and the AC drive receives you-defined fault 1. Then the AC drive reports Err27 and stops.

- Decided by A1-06

The VDI state is determined by the binary bit of A1-06. For example, to implement the function that the AC drive automatically enters the running state after power-on, perform the following setting:

- Allocate VDI1 with function 1 "Forward RUN (FWD)" (A1-00 = 1).
- Set A1-05 to xxx1: The state of VDI1 is decided by A1-06.
- Set A1-06 to xxx1: VDI1 is valid.
- Set F0-02 to 1: The command source to terminal control.
- Set F8-18 to 0: Startup protection is not enabled.

When the AC drive completes initialization after power-on, it detects that VDI1 is valid and VDI1 is allocated with the function of forward RUN. That is, the AC drive receives the forward RUN command from the terminal. Therefore, The AC drive starts to run in forward direction.

Function Code	Parameter Name	Setting Range	Default
A1-07	Function selection for AI1 used as DI	0-59	0
A1-08	Function selection for AI2 used as DI	0-59	0
A1-09	Function selection for AI3 used as DI	0-59	0
A1-10	State selection for AI used as DI	Unit's digit (AI1)	000
		0: High level valid 1: Low level valid	
		Ten's digit (AI2)	
		0, 1 (same as unit's digit)	
		Hundred's digit (AI3) 0, 1 (same as unit's digit)	

The functions of these parameters are to use AI as DI. When AI is used as DI, the AI state is high level if the AI input voltage is 7 V or higher and is low level if the AI input voltage is 3 V or lower. The AI state is hysteresis if the AI input voltage is between 3 V and 7 V. A1-10 is used to determine whether high level valid or low level valid when AI is used as DI.

The setting of AIs (used as DI) function is the same as that of DIs. For details, see the descriptions of group F4.

The following figure takes AI input voltage as an example to describe the relationship between AI input voltage and corresponding DI state.

Figure 6-33 Relationship of AI input voltage and corresponding DI status

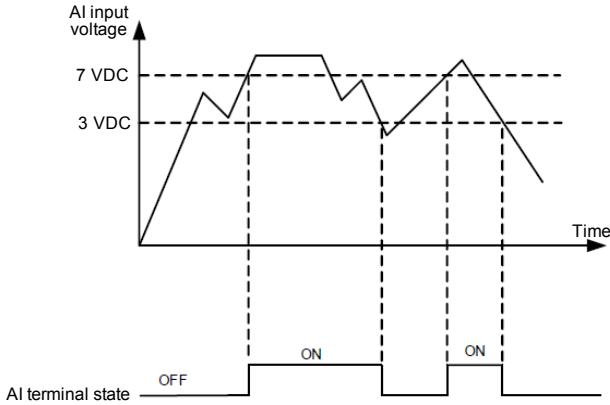

Function Code	Parameter Name	Setting Range	Default
A1-11	VDO1 function selection	0: Short with physical DIx internally 1-40: Refer to function selection of physical DO in group F5.	0
A1-12	VDO2 function selection	0: Short with physical DIx internally 1-40: Refer to function selection of physical DO in group F5.	0
A1-13	VDO3 function selection	0: Short with physical DIx internally 1-40: Refer to function selection of physical DO in group F5.	0
A1-14	VDO4 function selection	0: Short with physical DIx internally 1-40: Refer to function selection of physical DO in group F5.	0
A1-15	VDO5 function selection	0: Short with physical DIx internally 1-40: Refer to function selection of physical DO in group F5.	0
A1-16	VDO1 output delay	0.0-3600.0s	0.0s
A1-17	VDO2 output delay	0.0-3600.0s	0.0s
A1-18	VDO3 output delay	0.0-3600.0s	0.0s
A1-19	VDO4 output delay	0.0-3600.0s	0.0s
A1-20	VDO5 output delay	0.0-3600.0s	0.0s

Function Code	Parameter Name	Setting Range	Default
A1-21	VDO state selection	Unit's digit (VDO1)	00000
		0: Positive logic 1: Reverse logic	
		Ten's digit (VDO2)	
		0, 1 (same as unit's digit)	
		Hundred's digit (VDO3)	
		0, 1 (same as unit's digit)	
		Thousand's digit (VDO4)	
		0, 1 (same as unit's digit)	
		Ten thousand's digit (VDO5)	
		0, 1 (same as unit's digit)	

VDO functions are similar to the DO functions on the control board. The VDO can be used together with VDIx to implement some simple logic control.

- If VDO function is set to 0, the state of VDO1 to VDO5 is determined by the state of DI1 to DI5 on the control board. In this case, VDOx and DIx are one-to-one mapping relationship.
- If VDO function is set to non-0, the function setting and use of VDOx are the same as DO in group F5.

The VDOx state can be set in A1-21. The application examples of VDIx involve the use of VDOx, and see the examples for your reference.

Group A2 to A4: Motor 2 to Motor 4 Parameters

The MD380 can switch over the running among four motors. For the four motors, you can:

- Set motor nameplate parameters respectively
- Perform motor parameter auto-tuning respectively
- Select V/F control or vector control respectively
- Set encoder-related parameters respectively
- Set parameters related to V/F control or vector control independently

Groups A2, A3 and A4 respectively correspond to motor 2, motor 3 and motor 4. The parameters of the three groups are the same. Here we just list the parameters of group A2 for reference.

All parameters in group A2 have the same definition and usage as parameters of motor 1. For more details, refer to the descriptions of motor 1 parameters.

Function Code	Parameter Name	Setting Range	Default
A2-00	Motor type selection	0: Common asynchronous motor 1: Variable frequency asynchronous motor 2: Permanent magnetic synchronous motor	0

Function Code	Parameter Name	Setting Range	Default
A2-01	Rated motor power	0.1–1000.0 kW	Model dependent
A2-02	Rated motor voltage	1–2000 V	Model dependent
A2-03	Rated motor current	0.01–655.35 A (AC drive power ≤ 55 kW) 0.1–6553.5 A (AC drive power > 55 kW)	Model dependent
A2-04	Rated motor frequency	0.01 Hz to maximum frequency	Model dependent
A2-05	Rated motor rotational speed	1–65535 RPM	Model dependent
A2-06	Stator resistance (asynchronous motor)	0.001–65.535 Ω (AC drive power ≤ 55 kW) 0.0001–6.5535 Ω (AC drive power > 55 kW)	Model dependent
A2-07	Rotor resistance (asynchronous motor)	0.001–65.535 Ω (AC drive power ≤ 55 kW) 0.0001–6.5535 Ω (AC drive power > 55 kW)	Model dependent
A2-08	Leakage inductive reactance (asynchronous motor)	0.01–655.35 mH (AC drive power ≤ 55 kW) 0.001–65.535 mH (AC drive power > 55 kW)	Model dependent
A2-09	Mutual inductive reactance (asynchronous motor)	0.1–6553.5 mH (AC drive power ≤ 55 kW) 0.01–655.35 mH (AC drive power > 55 kW)	Model dependent
A2-10	No-load current (asynchronous motor)	0.01 A to A2-03 (AC drive power ≤ 55 kW) 0.1 A to A2-03 (AC drive power > 55 kW)	Model dependent
A2-16	Stator resistance (synchronous motor)	0.001–65.535 Ω (AC drive power ≤ 55 kW) 0.0001–6.5535 Ω (AC drive power > 55 kW)	Model dependent
A2-17	Shaft D inductance (synchronous motor)	0.01–655.35 mH (AC drive power ≤ 55 kW) 0.001–65.535 mH (AC drive power > 55 kW)	Model dependent
A2-18	Shaft Q inductance (synchronous motor)	0.01–655.35 mH (AC drive power ≤ 55 kW) 0.001–65.535 mH (AC drive power > 55 kW)	Model dependent
A2-20	Back EMF (synchronous motor)	0.1–6553.5 V	Model dependent
A2-27	Encoder pulses per revolution	1–65535	1024
A2-28	Encoder type	0: ABZ incremental encoder 1: UVW incremental encoder 2: Resolver 3: SIN/COS encoder 4: Wire-saving UVW encoder	0
A2-30	A, B phase sequence of ABZ incremental encoder	0: Forward 1: Reserve	0

Function Code	Parameter Name	Setting Range	Default
A2-31	Encoder installation angle	0.0°–359.9°	0.0°
A2-32	U, V, W phase sequence of UVW encoder	0: Forward 1: Reverse	0
A2-33	UVW encoder angle offset	0.0°–359.9°	0.0°
A2-34	Number of pole pairs of resolver	1–65535	1
A2-36	Encoder wire-break fault detection time	0.0s: No action 0.1–10.0s	0.0s
A2-37	Auto-tuning selection	0: No auto-tuning 1: Asynchronous motor static auto-tuning 2: Asynchronous motor complete auto-tuning 11: Synchronous motor with-load auto-tuning 12: Synchronous motor no-load auto-tuning	0
A2-38	Speed loop proportional gain 1	0–100	30
A2-39	Speed loop integral time 1	0.01–10.00s	0.50s
A2-40	Switchover frequency 1	0.00 to A2-43	5.00 Hz
A2-41	Speed loop proportional gain 2	0–100	15
A2-42	Speed loop integral time 2	0.01–10.00s	1.00s
A2-43	Switchover frequency 2	A2-40 to maximum output frequency	10.00 Hz
A2-44	Vector control slip gain	50%–200%	100%
A2-45	Time constant of speed loop filter	0.000–0.100s	0.000s
A2-46	Vector control over-excitation gain	0–200	64
A2-47	Torque upper limit source in speed control mode	0: A2-48 1: AI1 2: AI2 3: AI3 4: Pulse setting (DI5) 5: Via communication 6: MIN(AI1,AI2) 7: MIN(AI1,AI2)	0

Function Code	Parameter Name	Setting Range	Default
A2-48	Digital setting of torque upper limit in speed control mode	0.0%–200.0%	150.0%
A2-51	Excitation adjustment proportional gain	0–20000	2000
A2-52	Excitation adjustment integral gain	0–20000	1300
A2-53	Torque adjustment proportional gain	0–20000	2000
A2-54	Torque adjustment integral gain	0–20000	1300
A2-55	Speed loop integral property	Unit's digit: Integral separated 0: Disabled 1: Enabled	0
A2-56	Field weakening mode of synchronous motor	0: No field weakening 1: Direct calculation 2: Adjustment	0
A2-57	Field weakening degree of synchronous motor	50%–500%	100%
A2-58	Maximum field weakening current	1%–300%	50%
A2-59	Field weakening automatic adjustment gain	10%–500%	100%
A2-60	Field weakening integral multiple	2–10	2
A2-61	Motor 2 control mode	0: Sensorless flux vector control (SFVC) 1: Closed-loop vector control (CLVC) 2: Voltage/Frequency (V/F) control	0
A2-62	Motor 2 acceleration/ deceleration time	0: Same as motor 1 1: Acceleration/Deceleration time 1 2: Acceleration/Deceleration time 2 3: Acceleration/Deceleration time 3 4: Acceleration/Deceleration time 4	0
A2-63	Motor 2 torque boost	0.0%: Automatic torque boost 0.1%–30.0%	Model dependent
A2-65	Motor 2 oscillation suppression gain	0–100	Model dependent

Group A5: Control Optimization Parameters

Function Code	Parameter Name	Setting Range	Default
A5-00	DPWM switchover frequency upper limit	0.00–15.00 Hz	12.00 Hz

This parameter is valid only for V/F control.

It is used to determine the wave modulation mode in V/F control of asynchronous motor. If the frequency is lower than the value of this parameter, the waveform is 7-segment continuous modulation. If the frequency is higher than the value of this parameter, the waveform is 5-segment intermittent modulation.

The 7-segment continuous modulation causes more loss to switches of the AC drive but smaller current ripple. The 5-segment intermittent modulation causes less loss to switches of the AC drive but larger current ripple. This may lead to motor running instability at high frequency. Do not modify this parameter generally.

For instability of V/F control, refer to parameter F3-11. For loss to AC drive and temperature rise, refer to parameter F0-15.

Function Code	Parameter Name	Setting Range	Default
A5-01	PWM modulation mode	0: Asynchronous modulation 1: Synchronous modulation	0

This parameter is valid only for V/F control.

Synchronous modulation indicates that the carrier frequency varies linearly with the change of the output frequency, ensuring that the ratio of carrier frequency to output frequency remains unchanged. Synchronous modulation is generally used at high output frequency, which helps improve the output voltage quality.

At low output frequency (100 Hz or lower), synchronous modulation is not required. This is because asynchronous modulation is preferred when the ratio of carrier frequency to output frequency is high.

Synchronous modulation takes effect only when the running frequency is higher than 85 Hz. If the frequency is lower than 85 Hz, asynchronous modulation is always used.

Function Code	Parameter Name	Setting Range	Default
A5-02	Dead zone compensation mode selection	0: No compensation 1: Compensation mode 1 2: Compensation mode 2	1

Generally, you need not modify this parameter. Try to use a different compensation mode only when there is special requirement on the output voltage waveform quality or oscillation occurs on the motor.

For high power AC drive, compensation mode 2 is recommended.

Function Code	Parameter Name	Setting Range	Default
A5-03	Random PWM depth	0: Random PWM invalid 1–10	0

The setting of random PWM depth can make the shrill motor noise softer and reduce the electromagnetic interference. If this parameter is set to 0, random PWM is invalid.

Function Code	Parameter Name	Setting Range	Default
A5-04	Rapid current limit	0: Disabled 1: Enabled	1

The rapid current limit function can reduce the AC drive's overcurrent faults at maximum, guaranteeing uninterrupted running of the AC drive.

However, long-time rapid current limit may cause the AC drive to overheat, which is not allowed. In this case, the AC drive will report Err40, indicating the AC drive is overloaded and needs to stop.

Function Code	Parameter Name	Setting Range	Default
A5-05	Current detection compensation	0-100	5

It is used to set the AC drive current detection compensation. Too large value may lead to deterioration of control performance. Do not modify it generally.

Function Code	Parameter Name	Setting Range	Default
A5-06	Undervoltage threshold	60.0%-140.0%	100.0%

It is used to set the undervoltage threshold of Err09. The undervoltage threshold 100% of the AC drive of different voltage classes corresponds to different nominal values, as listed in the following table.

Table 6-11 Undervoltage nominal values for different voltage

Voltage Class	Nominal Value of Undervoltage threshold
Single-phase 220 V	200 V
Three-phase 220 V	200 V
Three-phase 380 V	350 V
Three-phase 480 V	450 V
Three-phase 690 V	650 V

Function Code	Parameter Name	Setting Range	Default
A5-07	SFVC optimization mode selection	0: No optimization 1: Optimization mode 1 2: Optimization mode 2	1

- 1: Optimization mode 1

It is used when the requirement on torque control linearity is high.

- 2: Optimization mode 2

It is used for the requirement on speed stability is high.

Function Code	Parameter Name	Setting Range	Default
A5-08	Dead-zone time adjustment	100%–200%	150%

It is only valid for 1140 V voltage class.

You can modify the value of this parameter to improve the voltage utilization rate. Too small value may system instability. Do not modify it generally.

Function Code	Parameter Name	Setting Range	Default
A5-09	Overvoltage threshold	200.0–2500.0 V	2000.0 V

It is used to set the overvoltage threshold of the AC drive. The default values of different voltage classes are listed in the following table.

Table 6-12 Overvoltage thresholds for different voltage classes

Voltage Class	Default Overvoltage Threshold
Single-phase 220 V	400.0 V
Three-phase 220 V	400.0 V
Three-phase 380 V	810.0 V
Three-phase 480 V	890.0 V
Three-phase 690 V	1300.0 V

Note

The default value is also the upper limit of the AC drive's internal overvoltage protection voltage. The parameter becomes effective only when the setting of A5-09 is lower than the default value. If the setting is higher than the default value, use the default value.

Group A6: AI Curve Setting

Function Code	Name	Setting Range	Default
A6-00	AI curve 4 minimum input	-10.00 V to A6-02	0.00 V
A6-01	Corresponding setting of AI curve 4 minimum input	-100.0%–100.0%	0.0%
A6-02	AI curve 4 inflexion 1 input	A6-00 to A6-04	3.00 V
A6-03	Corresponding setting of AI curve 4 inflexion 1 input	-100.0%–100.0%	30.0%
A6-04	AI curve 4 inflexion 1 input	A6-02 to A6-06	6.00 V
A6-05	Corresponding setting of AI curve 4 inflexion 1 input	-100.0%–100.0%	60.0%
A6-06	AI curve 4 maximum input	A6-06 to 10.00 V	10.00 V
A6-07	Corresponding setting of AI curve 4 maximum input	-100.0%–100.0%	100.0%
A6-08	AI curve 5 minimum input	-10.00 V to A6-10	0.00 V

Function Code	Name	Setting Range	Default
A6-09	Corresponding setting of AI curve 5 minimum input	-100.0%–100.0%	0.0%
A6-10	AI curve 5 inflexion 1 input	A6-08 to A6-12	3.00 V
A6-11	Corresponding setting of AI curve 5 inflexion 1 input	-100.0%–100.0%	30.0%
A6-12	AI curve 5 inflexion 1 input	A6-10 to A6-14	6.00 V
A6-13	Corresponding setting of AI curve 5 inflexion 1 input	-100.0%–100.0%	60.0%
A6-14	AI curve 5 maximum input	A6-14 to 10.00 V	10.00 V
A6-15	Corresponding setting of AI curve 5 maximum input	-100.0%–100.0%	100.0%

The function of curve 4 and curve 5 is similar to that curve 1 to curve 3, but curve 1 to curve 3 are lines, and curve 4 and curve 5 are 4-point curves, implementing more flexible corresponding relationship. The schematic diagram of curve 4 and curve 5 is shown in the following figure.

Figure 6-34 Schematic diagram curve 4 and curve 5

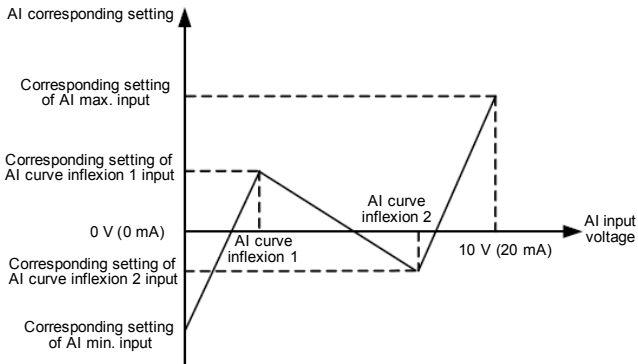

When setting curve 4 and curve 5, note that the curve's minimum input voltage, inflexion 1 voltage, inflexion 2 voltage and maximum voltage must be in increment order.

F4-34 (AI curve selection) is used to select curve for AI1 to AI3.

Function Code	Parameter Name	Setting Range	Default
A6-16	Jump point of AI1 input corresponding setting	-100.0%–100.0%	0.0%
A6-17	Jump amplitude of AI1 input corresponding setting	0.0%–100.0%	0.5%
A6-18	Jump point of AI2 input corresponding setting	-100.0%–100.0%	0.0%
A6-19	Jump amplitude of AI2 input corresponding setting	0.0%–100.0%	0.5%

Function Code	Parameter Name	Setting Range	Default
A6-20	Jump point of AI3 input corresponding setting	-100.0%–100.0%	0.0%
A6-21	Jump amplitude of AI3 input corresponding setting	0.0%–100.0%	0.5%

The AI terminals (AI1 to AI3) of the MD380 all support the corresponding setting jump function, which fixes the AI input corresponding setting at the jump point when AI input corresponding setting jumps around the jump range.

For example, AI1 input voltage jumps around 5.00 V and the jump range is 4.90–5.10 V. AI1 minimum input 0.00 V corresponds to 0.0% and maximum input 10.00 V corresponds to 100.0%. The detected AI1 input corresponding setting varies between 49.0% and 51.0%.

If you set A6-16 to 50.0% and A6-17 to 1.0%, then the obtained AI1 input corresponding setting is fixed to 50.0%, eliminating the fluctuation effect.

Group A7: User Programmable Function

Group A8: Point-point Communication

Function Code	Parameter Name	Setting Range	Default
A8-00	Point-point communication selection	0: Disabled 1: Enabled	0

It is used to decide whether to enable point-point communication.

Point-point communication indicates direct communication between two or more MD380 AC drives by using CANlink. The master gives target frequency or target torque to one or multiple slaves according to its own frequency or torque signal.

If multiple AC drives are connected by using CANlink cards, the terminal resistor of the CANlink card connected to the end AC drive shall be switched on.

If point-point communication is enabled, the CANlink communication addresses of the AC drives are automatically matched without special setting.

The point-point communication rate is set in FD-00.

Function Code	Name	Setting Range	Default
A8-01	Master and slave selection	0: Master 1: Slave	0

This parameter is used to determine whether the AC drive is master or slave.

At point-point communication, you only need to set the CANlink communication baud rate. The communication addresses are allocated automatically based on whether the AC drive is master or slave.

Function Code	Parameter Name	Setting Range	Default
A8-02	Slave following master command selection	0: Slave not following running commands of the master 1: Slave following running commands of the master	0

When A8-01 (Master and slave selection) is set to 1 (Slave) and F0-02 (Command source selection) is set to 2 (Communication control), if A8-02 is set to 1, the slave follows the master to start or stop.

Function Code	Name	Setting Range	Default
A8-03	Usage of data received by slave	0: Torque setting 1: Frequency setting	0

It is used to determine whether the slave uses data received from the master for torque setting or frequency setting. This function can be used only when the frequency source or torque source must be communication setting.

When the AC drive is a slave in point-point communication and receives data for torque setting, 100.00% of the received data corresponds to 200.0% of torque setting, unrelated to A0-03. If zero offset of the slave is 0.00% and the gain is 1.00, it means that the slave directly takes the output torque of the master as the target torque.

When the AC drive is a slave in point-point communication and receives data for frequency setting, 100.00% of the received data corresponds to the value of F0-10 (Maximum frequency).

For example, to balance the load, do the following settings.

Table 6-14 Settings for balancing the load

Master	Slave
A0-00 = 0: Speed control	A0-00 = 1: Torque control
A8-00 = 1: Point-point communication enabled	A8-00 = 1: Point-point communication enabled
A8-01 = 0: Master in point-point communication	A8-01 = 1: Slave in point-point communication
A8-02 = 0: Data source from master being output torque	A8-03 = 0: Slave receiving data for torque setting
	A0-01 = 5: Torque source in torque control set to communication setting

Function Code	Parameter Name	Setting Range	Default
A8-04	Zero offset of received data (torque)	-100.00%–100.00%	0.00%
A8-05	Gain of received data (torque)	-10.00–10.00	1.00

These two parameters are used to adjust data received from the master and define the torque reference relationship between the master and the slave.

If "b" expresses the zero offset of received data, "k" expresses the gain, and "y" expresses the actually used data. The actually used data can be obtained based on the formula:

$$y = kx + b$$

The value y ranges from -100.00% to 100.00%.

Function Code	Parameter Name	Setting Range	Default
A8-06	Point-point communication interruption detection time	0.0–10.0s	1.0s

It is used to set the point-point communication interruption time at which this fault is detected. If it is set to 0, it indicates no detection.

Function Code	Parameter Name	Setting Range	Default
A8-07	Master data sending cycle	0.001–10.000s	0.001s

It is used to set the data sending cycle of the master in point-point communication.

Function Code	Parameter Name	Setting Range	Default
A8-08	Zero offset of received data (frequency)	-100.00%–100.00%	0.00%
A8-09	Gain of received data (frequency)	-10.00–10.00	1.00

These two parameters are used to adjust data received from the master and define the frequency reference relationship between the master and the slave.

If "b" expresses the zero offset of received data, "k" expresses the gain, and "y" expresses the actually used data. The actually used data can be obtained based on the formula:

$$y = kx + b$$

The value y ranges from -100.00% to 100.00%.

Function Code	Parameter Name	Setting Range	Default
A8-10	Runaway prevention coefficient	0.00%–100.00%	10.00%

When the slave is set to torque control and follows the master to output torque to implement load allocation, this parameter becomes active.

If it is set to 0.00%, it indicates that the runaway prevention function is disabled. If it is set to another value, the system can effectively detect whether the slave is in the runaway state and performs efficient protection. The recommended value range is 5.00%–20.00%.

Group AC: AI/AO Correction

Function Code	Parameter Name	Setting Range	Default
AC-00	AI1 measured voltage 1	0.500–4.000 V	Factory-corrected
AC-01	AI1 displayed voltage 1	0.500–4.000 V	Factory-corrected
AC-02	AI1 measured voltage 2	6.000–9.999 V	Factory-corrected
AC-03	AI1 displayed voltage 2	6.000–9.999 V	Factory-corrected
AC-04	AI2 measured voltage 1	0.500–4.000 V	Factory-corrected
AC-05	AI2 displayed voltage 1	0.500–4.000 V	Factory-corrected
AC-06	AI2 measured voltage 2	6.000–9.999 V	Factory-corrected
AC-07	AI2 displayed voltage 2	9.999–10.000 V	Factory-corrected
AC-08	AI3 measured voltage 1	9.999–10.000 V	Factory-corrected
AC-09	AI3 displayed voltage 1	9.999–10.000 V	Factory-corrected
AC-10	AI3 measured voltage 2	9.999–10.000 V	Factory-corrected
AC-11	AI3 displayed voltage 2	9.999–10.000 V	Factory-corrected

These parameters are used to correct the AI to eliminate the impact of AI zero offset and gain.

They have been corrected upon delivery. When you resume the factory values, these parameters will be restored to the factory-corrected values. Generally, you need not perform correction in the applications.

Measured voltage indicates the actual output voltage value measured by instruments such as the multimeter. Displayed voltage indicates the voltage display value sampled by the AC drive. For details, refer to U0-21, U0-22 and U0-23.

During correction, send two voltage values to each AI terminal, and save the measured values and displayed values to the function codes AC-00 to AC-11. Then the AC drive will automatically perform AI zero offset and gain correction.

If the input voltage and the actual voltage sampled by the AC drive are inconsistent, perform correction on site. Take AI1 as an example. The on-site correction is as follows:

- 1) Send a voltage signal (approximately 2 V) to AI1.
- 2) Measure the AI1 voltage and save it to AC-00.
- 3) View the displayed value of U0-21 and save the value to AC-01.
- 4) Send a voltage signal (approximately 8 V) to AI1.
- 5) Measure AI1 voltage and save it to AC-02.
- 6) View the displayed value of U0-21 and save the value to AC-03.

At correction of AI2 and AI3, the actually sampled voltage is respectively queried in U0-22 and U0-23.

For AI1 and AI2, 2 V and 8 V are suggested as the correction voltages. For AI3, -8 V and 8 V are suggested.

Function Code	Parameter Name	Setting Range	Default
AC-12	AO1 target voltage 1	0.500–4.000 V	Factory-corrected
AC-13	AO1 measured voltage 1	0.500–4.000 V	Factory-corrected
AC-14	AO1 target voltage 2	6.000–9.999 V	Factory-corrected
AC-15	AO1 measured voltage 2	6.000–9.999 V	Factory-corrected
AC-16	AO2 target voltage 1	0.500–4.000 V	Factory-corrected
AC-17	AO2 measured voltage 1	0.500–4.000 V	Factory-corrected
AC-18	AO2 target voltage 2	6.000–9.999 V	Factory-corrected
AC-19	AO2 measured voltage 2	6.000–9.999 V	Factory-corrected
AC-20	AI2 measured current 1	0.000–20.000 mA	Factory corrected
AC-21	AI2 sampling current 1	0.000–20.000 mA	Factory corrected
AC-22	AI2 measured current 2	0.000–20.000 mA	Factory corrected
AC-23	AI2 sampling current 2	0.000–20.000 mA	Factory corrected
AC-24	AO1 ideal current 1	0.000–20.000 mA	Factory corrected
AC-25	AO1 sampling current 1	0.000–20.000 mA	Factory corrected
AC-26	AO1 ideal current 2	0.000–20.000 mA	Factory corrected
AC-27	AO1 sampling current 2	0.000–20.000 mA	Factory corrected

These parameters are used to correct the AO.

They have been corrected upon delivery. When you resume the factory values, these parameters will be restored to the factory-corrected values. You need not perform correction in the applications.

Target voltage indicates the theoretical output voltage of the AC drive. Measured voltage indicates the actual output voltage value measured by instruments such as the multimeter.

Group U0: Monitoring Parameters

Group U0 is used to monitor the AC drive's running state. You can view the parameter values by using operation panel, convenient for on-site commissioning, or from the host computer by means of communication (address: 0x7000-0x7044).

U0-00 to U0-31 are the monitoring parameters in the running and stop state defined by F7-03 and F7-04. For more details, see Table 6-1.

Function Code	Parameter Name	Display Range
U0-00	Running frequency	0.00–320.00 Hz (F0-22 = 2)
U0-01	Set frequency	0.00–3200.0 Hz (F0-22 = 1)

These two parameters display the absolute value of theoretical running frequency and set frequency. For the actual output frequency of the AC drive, see U0-19.

Function Code	Parameter Name	Display Range
U0-02	Bus voltage	0.0–3000.0 V

It displays the AC drive's bus voltage.

Function Code	Parameter Name	Display Range
U0-03	Output voltage	0–1140 V

It displays the AC drive's output voltage in the running state.

Function Code	Parameter Name	Display Range
U0-04	Output current	0.00–655.35 A (AC drive power ≤ 55 kW) 0.0–6553.5 A (AC drive power > 55 kW)

It displays the AC drive's output current in the running state.

Function Code	Name	Display Range
U0-05	Output power	0–32767

It displays the AC drive's output power in the running state.

Function Code	Parameter Name	Display Range
U0-06	Output torque	-200.0%–200.0%

It displays the AC drive's output torque in the running state.

Function Code	Parameter Name	Display Range
U0-07	DI state	0–32767

It displays the current state of DI terminals. After the value is converted into a binary number, each bit corresponds to a DI. "1" indicates high level signal, and "0" indicates low level signal. The corresponding relationship between bits and DIs is described in the following table.

Bit0	Bit1	Bit2	Bit3	Bit4	Bit5	Bit6	Bit7	Bit8	Bit9
DI1	DI2	DI3	DI4	DI5	DI6	DI7	DI8	DI9	DI10
Bit10	Bit11	Bit12	Bit13	Bit10	Bit11	Bit12	Bit13	Bit14	Bit15
VDI1	VDI2	VDI3	VDI4	VDI1	VDI2	VDI3	VDI4	VDI5	

Function Code	Parameter Name	Display Range
U0-08	DO state	0–1023

It indicates the current state of DO terminals. After the value is converted into a binary number, each bit corresponds to a DO. "1" indicates high level signal, and "0" indicates low level signal. The corresponding relationship between bits and DOs is described in the following table.

Table 6-15 Corresponding relationship between bits and DOs

Bit0	Bit1	Bit2	Bit3	Bit4	Bit5
DO3	Relay 1	Relay 2	DO1	DO2	VDO1
Bit6	Bit7	Bit8	Bit9	Bit10	Bit11
VDO2	VDO3	VDO4	VDO5		

Function Code	Parameter Name	Display Range
U0-10	AI2 voltage (V)/current (mA)	0.00–10.57 V 0.00–20.00 mA

When F4-40 is set to 0, AI2 sampling data is displayed in the unit of V.

When F4-40 is set to 1, AI2 sampling data is displayed in the unit of mA.

Function Code	Parameter Name	Display Range
U0-14	Load speed	0–65535

For more details, see the description of F7-12.

Function Code	Parameter Name	Display Range
U0-15	PID setting	0–65535
U0-16	PID feedback	0–65535

They display the PID setting value and PID feedback value.

- PID setting = PID setting (percentage) x FA-04
- PID feedback = PID feedback (percentage) x FA-04

Function Code	Parameter Name	Display Range
U0-18	Input pulse frequency	0.00–100.00 kHz

It displays the high-speed pulse sampled frequency of DI5, in minimum unit of 0.01 kHz.

Function Code	Parameter Name	Display Range
U0-19	Feedback speed	-320.00–320.00 Hz -3200.0–3200.0 Hz

It displays the actual output frequency of the AC drive.

- If F0-22 (Frequency reference resolution) is set to 1, the display range is -3200.00–3200.00 Hz.
- If F0-22 (Frequency reference resolution) is set to 2, the display range is -320.00Hz–320.00 Hz.

Function Code	Parameter Name	Display Range
U0-20	Remaining running time	0.0–6500.0 min

It displays the remaining running time when the timing operation is enabled. For details on timing operation, refer to F8-42 to F8-44.

Function Code	Parameter Name	Display Range
U0-21	AI1 voltage before correction	0.00–10.57 V
U0-22	AI2 voltage (V)/ current (mA) before correction	0.00–10.57 V 0.00–20.00 mA
U0-23	AI3 voltage before correction	-10.57–10.57 V

They display the AI sampling voltage/current value of AI. The actually used voltage/current is obtained after linear correction to reduce the deviation between the sampled voltage/current and the actual input voltage/current.

For actual corrected voltage, see U0-09, U0-10 and U0-11. Refer to group AC for the correction mode.

Function Code	Parameter Name	Display Range
U0-24	Linear speed	0-65535 m/min

It displays the linear speed of the DI5 high-speed pulse sampling. The unit is meter/minute.

The linear speed is obtained according to the actual number of pulses sampled per minute and FB-07 (Number of pulses per meter).

Function Code	Parameter Name	Display Range
U0-27	Pulse input frequency	0-65535 Hz

It displays the DI5 high-speed pulse sampling frequency, in minimum unit of 1 Hz. It is the same as U0-18, except for the difference in units.

Function Code	Parameter Name	Display Range
U0-28	Communication setting value	-100.00%-100.00%

It displays the data written by means of the communication address 0x1000.

Function Code	Parameter Name	Display Range
U0-29	Encoder feedback speed	-320.00-320.00 Hz -3200.0-3200.0 Hz

It displays the motor running frequency measured by the encoder.

- If F0-22 (Frequency reference resolution) is 1, the display range is -3200.0-3200.0 Hz.
- If F0-22 (Frequency reference resolution) is 2, the display range is -320.00-320.00 Hz.

Function Code	Name	Display Range
U0-30	Main frequency X	0.00-320.00 Hz 0.0-3200.0 Hz

It displays the setting of main frequency X.

- If F0-22 (Frequency reference resolution) is 1, the display range is -3200.0-3200.0 Hz.
- If F0-22 (Frequency reference resolution) is 2, the display range is -320.00-320.00 Hz.

Function Code	Parameter Name	Display Range
U0-31	Auxiliary frequency Y	0.00-320.00 Hz 0.0-3200.0 Hz

It displays the setting of auxiliary frequency Y.

- If F0-22 (frequency reference resolution) is 1, the display range is -3200.0–3200.0 Hz.
- If F0-22 (frequency reference resolution) is 2, the display range is -320.00–320.00 Hz.

Function Code	Parameter Name	Display Range
U0-33	Synchronous motor rotor position	0.0°–359.9°

It displays the rotor position of the synchronous motor.

Function Code	Parameter Name	Display Range
U0-34	Motor temperature	0–200 °C

It displays the motor temperature obtained by means of AI3 sampling. For the motor temperature detection, see F9-56.

Function Code	Parameter Name	Display Range
U0-35	Target torque	-200.0%–200.0%

It displays the current torque upper limit.

Function Code	Parameter Name	Display Range
U0-36	Resolver position	0–4095

It displays the current resolver position.

Function Code	Parameter Name	Display Range
U0-37	Power factor angle	-

It displays the current power factor angle.

Function Code	Parameter Name	Display Range
U0-38	ABZ position	0–65535

It displays the phase A and B pulse counting of the current ABZ or UVW encoder. This value is four times the number of pulses that the encoder runs. For example, if the display is 4000, the actual number of pulses that the encoder runs is $4000/4 = 1000$.

The value increase when the encoder rotates in forward direction and decreases when the encoder rotates in reverse direction. After increasing to 65535, the value starts to increase from 0 again. After decreasing to 0, the value starts to decrease from 65535 again.

You can check whether the installation of the encoder is normal by viewing U0-38.

Function Code	Parameter Name	Display Range
U0-39	Target voltage upon V/F separation	0 V to rated motor voltage
U0-40	Output voltage upon V/F separation	0 V to rated motor voltage

They display the target output voltage and current actual output voltage in the V/F separation state. For V/F separation, see the descriptions of group F3.

Function Code	Parameter Name	Display Range
U0-41	DI state visual display	-

It displays the DI state visually and the display format is shown in the following figure.

Figure 6-34 Display format of the DI state

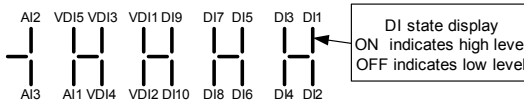

Function Code	Parameter Name	Display Range
U0-42	DO state visual display	-

It displays the DO state visually and the display format is shown in the following figure.

Figure 6-35 Display format of the DO state

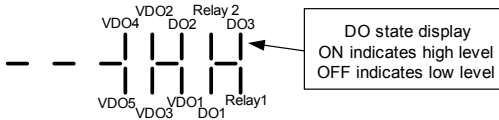

Function Code	Parameter Name	Display Range
U0-43	DI function state visual display 1	-

It displays whether the DI functions 1-40 are valid. The operation panel has five 7-segment LEDs and each 7-segment LED displays the selection of eight functions. The 7-segment LED is defined in the following figure.

Figure 6-36 Definition of 7-segment LED

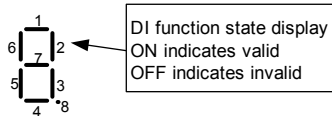

The 7-segment LED display functions 1-8, 9-16, 17-24, 25-32 and 33-40 respectively from right to left.

Function Code	Parameter Name	Display Range
U0-44	DI function state visual display 2	-

It displays whether the DI functions 41-59 are valid. The display format is similar to U0-43. The 7-segment LEDs display functions 41-48, 49-56 and 57-59, respectively from right to left.

Function Code	Parameter Name	Display Range
U0-58	Phase Z counting	0-65535

It displays the phase Z counting of the current ABZ or UVW encoder. The value increases or decreases by 1 every time the encoder rotates one revolution forwardly or reversely.

You can check whether the installation of the encoder is normal by viewing U0-58.

Function Code	Parameter Name	Display Range
U0-59	Current set frequency	-100.00%~100.00%
U0-60	Current running frequency	-100.00%~100.00%

It displays the current set frequency and running frequency. 100.00% corresponds to the AC drive's maximum frequency (F0-10).

Function Code	Parameter Name	Display Range
U0-61	AC drive running state	0-65535

It displays the running state of the AC drive. The data format is listed in the following table:

U0-61	Bit0	0: Stop
	Bit1	1: Forward 2: Reverse
	Bi2	0: Constant
	Bit3	1: Accelerate 2: Decelerate
	Bit4	0: Bus voltage normal 1: Undervoltage

Function Code	Name	Display Range
U0-62	Current fault code	0-99

It displays the current fault code.

Function Code	Name	Display Range
U0-63	Sent value of point-point communication	-100.00%~100.00%
U0-64	Received value of point-point communication	-100.00%~100.00%

It displays the data at point-point communication. U0-63 is the data sent by the master, and U0-64 is the data received by the slave.

Function Code	Name	Display Range
U0-65	Torque upper limit	-200.00%~200.00%

It displays the current setting torque upper limit.



EMC

Chapter 7 EMC

7.1 Definition of Terms

1) EMC

Electromagnetic compatibility (EMC) describes the ability of electronic and electrical devices or systems to work properly in the electromagnetic environment and not to generate electromagnetic interference that influences other local devices or systems.

In other words, EMC includes two aspects: The electromagnetic interference generated by a device or system must be restricted within a certain limit; the device or system must have sufficient immunity to the electromagnetic interference in the environment.

2) First environment

Environment that includes domestic premises, it also includes establishments directly connected without intermediate transformers to a low-voltage power supply network which supplies buildings used for domestic purposes

3) Second environment

Environment that includes all establishments other than those directly connected to a low-voltage power supply network which supplies buildings used for domestic purposes

4) Category C1 AC drive

Power Drive System (PDS) of rated voltage less than 1 000 V, intended for use in the first environment

5) Category C2 AC drive

PDS of rated voltage less than 1 000 V, which is neither a plug in device nor a movable device and, when used in the first environment, is intended to be installed and commissioned only by a professional

6) Category C3 AC drive

PDS of rated voltage less than 1 000 V, intended for use in the second environment and not intended for use in the first environment

7) Category C4 AC drive

PDS of rated voltage equal to or above 1 000 V, or rated current equal to or above 400 A, or intended for use in complex systems in the second environment

7.2 Introduction to EMC Standard

7.2.1 EMC Standard

The MD380 series AC drive satisfies the requirements of standard EN 61800-3: 2004 Category C2. The AC drives are applied to both the first environment and the second environment.

7.2.2 Installation Environment

The system manufacturer using the AC drive is responsible for compliance of the system with the European EMC directive. Based on the application of the system, the integrator must ensure that the system complies with standard EN 61800-3: 2004 Category C2, C3 or C4.

The system (machinery or appliance) installed with the AC drive must also have the CE mark. The system integrator is responsible for compliance of the system with the EMC directive and standard EN 61800-3: 2004 Category C2.

Warning
If applied in the first environment, the AC drive may generate radio interference. Besides the CE compliance described in this chapter, users must take measures to avoid such interference, if necessary.

7.3 Selection of Peripheral EMC Devices

7.3.1 Installation of EMC Input Filter on Power Input Side

An EMC filter installed between the AC drive and the power supply can not only restrict the interference of electromagnetic noise in the surrounding environment on the AC drive, but also prevents the interference from the AC drive on the surrounding equipment.

The MD380 series AC drive satisfies the requirements of category C2 only with an EMC filter installed on the power input side. The installation precautions are as follows:

- Strictly comply with the ratings when using the EMC filter. The EMC filter is category I electric apparatus, and therefore, the metal housing ground of the filter should be in good contact with the metal ground of the installation cabinet on a large area, and requires good conductive continuity. Otherwise, it will result in electric shock or poor EMC effect.
- The ground of the EMC filter and the PE conductor of the AC drive must be tied to the same common ground. Otherwise, the EMC effect will be affected seriously.
- The EMC filter should be installed as closely as possible to the power input side of the AC drive.

The following table lists the recommended manufacturers and models of EMC filters for the MD380 series AC drive. Select a proper one based on actual requirements.

Table 7-1 Recommended manufacturers and models of EMC filters

AC Drive Model	Power Capacity (kVA)	Rated Input Current (A)	AC Input Filter Model (Changzhou Jianli)	AC Input Filter Model (Schaffner)
Three-phase 380 V, 50/60 Hz				
MD380T0.7GB	1.5	3.4	DL-5EBK5	FN 3258-7-44
MD380T1.5GB	3	5	DL-5EBK5	FN 3258-7-44
MD380T2.2GB	4	5.8	DL-10EBK5	FN 3258-7-44
MD380T3.7GB	5.9	10.5	DL-16EBK5	FN 3258-16-33
MD380T5.5GB	8.9	14.6	DL-16EBK5	FN 3258-16-33

AC Drive Model	Power Capacity (kVA)	Rated Input Current (A)	AC Input Filter Model (Changzhou Jianli)	AC Input Filter Model (Schaffner)
MD380T7.5GB	11	20.5	DL-25EBK5	FN 3258-30-33
MD380T11GB	17	26	DL-35EBK5	FN 3258-30-33
MD380T15GB	21	35	DL-35EBK5	FN 3258-42-33
MD380T18.5G	24	38.5	DL-50EBK5	FN 3258-42-33
MD380T22G	30	46.5	DL-50EBK5	FN 3258-55-34
MD380T30G	40	62	DL-65EBK5	FN 3258-75-34
MD380T37G	57	76	DL-80EBK5	FN 3258-100-35
MD380T45G	69	92	DL-100EBK5	FN 3258-100-35
MD380T55G	85	113	DL-130EBK5	FN 3258-130-35
MD380T75G	114	157	DL-160EBK5	FN 3258-180-40
MD380T90G	134	180	DL-200EBK5	FN 3258-180-40
MD380T110G	160	214	DL-250EBK5	FN 3270H-250-99
MD380T132G	192	256	DL-300EBK3	FN 3270H-320-99
MD380T160G	231	307	DL-400EBK3	FN 3270H-320-99
MD380T200G	250	385	DL-400EBK3	FN 3270H-400-99
MD380T220G	280	430	DL-600EBK3	FN 3270H-600-99
MD380T250G	355	468	DL-600EBK3	FN 3270H-600-99
MD380T280G	396	525	DL-600EBK3	FN 3270H-600-99
MD380T315G	445	590	DL-600EBK3	FN 3270H-600-99
MD380T355G	500	665	DL-700EBK3	FN 3270H-800-99
MD380T400G	565	785	DL-800EBK3	FN 3270H-800-99
Three-phase 480 V, 50/60 Hz				
MD380-5T0.7GB	1.5	3.4	DL-5EBK5	FN 3258-7-44
MD380-5T1.5GB	3	5	DL-5EBK5	FN 3258-7-44
MD380-5T2.2GB	4	5.8	DL-10EBK5	FN 3258-7-44
MD380-5T3.7GB	5.9	10.5	DL-16EBK5	FN 3258-16-33
MD380-5T5.5GB	8.9	14.6	DL-16EBK5	FN 3258-16-33
MD380-5T7.5GB	11	20.5	DL-25EBK5	FN 3258-30-33
MD380-5T11GB	17	26	DL-35EBK5	FN 3258-30-33
MD380-5T15GB	21	35	DL-35EBK5	FN 3258-42-33
MD380-5T18.5G	24	38.5	DL-50EBK5	FN 3258-42-33
MD380-5T22G	30	46.5	DL-50EBK5	FN 3258-55-34
MD380-5T30G	40	62	DL-65EBK5	FN 3258-75-34
MD380-5T37G	57	76	DL-80EBK5	FN 3258-100-35
MD380-5T45G	69	92	DL-100EBK5	FN 3258-100-35
MD380-5T55G	85	113	DL-130EBK5	FN 3258-130-35
MD380-5T75G	114	157	DL-160EBK5	FN 3258-180-40
MD380-5T90G	134	180	DL-200EBK5	FN 3258-180-40

AC Drive Model	Power Capacity (kVA)	Rated Input Current (A)	AC Input Filter Model (Changzhou Jianli)	AC Input Filter Model (Schaffner)
MD380-5T110G	160	214	DL-250EBK5	FN 3270H-250-99
MD380-5T132G	192	256	DL-300EBK3	FN 3270H-320-99
MD380-5T160G	231	307	DL-400EBK3	FN 3270H-320-99
MD380-5T200G	250	385	DL-400EBK3	FN 3270H-400-99
MD380-5T220G	280	430	DL-600EBK3	FN 3270H-600-99
MD380-5T250G	355	468	DL-600EBK3	FN 3270H-600-99
MD380-5T280G	396	525	DL-600EBK3	FN 3270H-600-99
MD380-5T315G	445	590	DL-600EBK3	FN 3270H-600-99
MD380-5T355G	500	665	DL-700EBK3	FN 3270H-800-99
MD380-5T400G	565	785	DL-800EBK3	FN 3270H-800-99
Three-phase 690 V, 50/60 Hz				
MD380-7T55G	84	70	DL-100EBK5-CHV	-
MD380-7T75G	107	90	DL-100EBK5-CHV	-
MD380-7T90G	125	105	DL-130EBK51-CHV	-
MD380-7T110G	155	130	DL-160EBK5-CHV	-
MD380-7T132G	192	170	DL-200EBK5-CHV	-
MD380-7T160G	231	200	DL-250EBK31/60	-
MD380-7T200G	250	235	DL-250EBK31/60	-
MD380-7T220G	280	247	DL-250EBK31/60	-
MD380-7T250G	355	265	No recommendation	-
MD380-7T280G	396	305	No recommendation	-
MD380-7T315G	445	350	No recommendation	-
MD380-7T355G	500	382	No recommendation	-
MD380-7T400G	565	435	DL-600EBK35/60	-
MD380-7T450G	630	490	DL-600EBK35/60	-
MD380-7T500G	700	595	DL-600EBK35/60	-

7.3.2 Installation of AC Input Reactor on Power Input Side

An AC input reactor is installed to eliminate the harmonics of the input current. As an optional device, the reactor can be installed externally to meet strict requirements of an application environment for harmonics. The following table lists the recommended manufacturers and models of input reactors.

Table 7-2 Recommended manufacturers and models of AC input reactors

AC Drive Model	Rated Input Current (A)	AC Input Reactor Model (Inovance)
Three-phase power: 380 V, 50/60 Hz		
MD380T0.7GB	3.4	MD-ACL-7-4T-222-2%
MD380T1.5GB	5	MD-ACL-7-4T-222-2%

AC Drive Model	Rated Input Current (A)	AC Input Reactor Model (Inovance)
MD380T2.2GB	5.8	MD-ACL-7-4T-222-2%
MD380T3.7GB	10.5	MD-ACL-10-4T-372-2%
MD380T5.5GB	14.6	MD-ACL-15-4T-552-2%
MD380T7.5GB	20.5	MD-ACL-30-4T-113-2%
MD380T11GB	26	MD-ACL-30-4T-113-2%
MD380T15GB	35	MD-ACL-40-4T-153-2%
MD380T18.5G	38.5	MD-ACL-40-4T-153-2%
MD380T22G	46.5	MD-ACL-50-4T-183-2%
MD380T30G	62	MD-ACL-80-4T-303-2%
MD380T37G	76	MD-ACL-80-4T-303-2%
MD380T45G	92	MD-ACL-120-4T-453-2%
MD380T55G	113	MD-ACL-120-4T-453-2%
MD380T75G	157	MD-ACL-200-4T-753-2%
MD380T90G	180	MD-ACL-200-4T-753-2%
MD380T110G	214	MD-ACL-250-4T-114-2%
MD380T132G	256	MD-ACL-330-4T-164-2%
MD380T160G	307	MD-ACL-330-4T-164-2%
MD380T200G	385	MD-ACL-490-4T-224-2%
MD380T220G	430	MD-ACL-490-4T-224-2%
MD380T250G	468	MD-ACL-490-4T-224-2%
MD380T280G	525	MD-ACL-660-4T-304-2%
MD380T315G	590	MD-ACL-660-4T-304-2%
MD380T355G	665	MD-ACL-800-4T-384-2%
MD380T400G	785	MD-ACL-800-4T-384-2%
Three-phase power: 480 V, 50/60 Hz		
MD380-5T0.7GB	3.4	MD-ACL-7-4T-222-2%
MD380-5T1.5GB	5	MD-ACL-7-4T-222-2%
MD380-5T2.2GB	5.8	MD-ACL-7-4T-222-2%
MD380-5T3.7GB	10.5	MD-ACL-10-4T-372-2%
MD380-5T5.5GB	14.6	MD-ACL-15-4T-552-2%
MD380-5T7.5GB	20.5	MD-ACL-30-4T-113-2%
MD380-5T11GB	26	MD-ACL-30-4T-113-2%
MD380-5T15GB	35	MD-ACL-40-4T-153-2%
MD380-5T18.5G	38.5	MD-ACL-40-4T-153-2%
MD380-5T22G	46.5	MD-ACL-50-4T-183-2%
MD380-5T30G	62	MD-ACL-80-4T-303-2%
MD380-5T37G	76	MD-ACL-80-4T-303-2%
MD380-5T45G	92	MD-ACL-120-4T-453-2%
MD380-5T55G	113	MD-ACL-120-4T-453-2%
MD380-5T75G	157	MD-ACL-200-4T-753-2%

AC Drive Model	Rated Input Current (A)	AC Input Reactor Model (Inovance)
MD380-5T90G	180	MD-ACL-200-4T-753-2%
MD380-5T110G	214	MD-ACL-250-4T-114-2%
MD380-5T132G	256	MD-ACL-330-4T-164-2%
MD380-5T160G	307	MD-ACL-330-4T-164-2%
MD380-5T200G	385	MD-ACL-490-4T-224-2%
MD380-5T220G	430	MD-ACL-490-4T-224-2%
MD380-5T250G	468	MD-ACL-490-4T-224-2%
MD380-5T280G	525	MD-ACL-660-4T-304-2%
MD380-5T315G	590	MD-ACL-660-4T-304-2%
MD380-5T355G	665	MD-ACL-800-4T-384-2%
MD380-5T400G	785	MD-ACL-800-4T-384-2%
Three-phase power: 690 V, 50/60 Hz		
MD380-7T55G	70	ACL-0080-EISC-EM19B
MD380-7T75G	90	ACL-0090-EISC-EM19B
MD380-7T90G	105	ACL-0120-EISH-EM13B
MD380-7T110G	130	ACL-0120-EISH-EM13B
MD380-7T132G	170	ACL-0150-EISH-EM11B
MD380-7T160G	200	ACL-0200-EISH-E80UB
MD380-7T200G	235	ACL-0250-EISH-E65UB
MD380-7T220G	247	ACL-0250-EISH-E65UB
MD380-7T250G	265	ACL-0290-EISH-E50UB
MD380-7T280G	305	ACL-0330-EISH-E50UB
MD380-7T315G	350	ACL-0330-EISH-E50UB
MD380-7T355G	382	ACL-0390-EISH-E44UB
MD380-7T400G	435	ACL-0490-EISH-E35UB
MD380-7T450G	490	ACL-0490-EISH-E35UB
MD380-7T500G	595	ACL-0600-EISH-E25UB

7.3.3 Installation of AC Output Reactor on Power Output Side

Whether to install an AC output reactor on the power output side is dependent on the actual situation. The cable connecting the AC drive and the motor should not be too long; capacitance enlarges when an over-long cable is used and thus high-harmonics current may be easily generated.

If the length of the output cable is equal to or greater than the value in the following table, install an AC output reactor on the power output side of the AC drive.

Table 7-3 Cable length threshold when an AC output reactor is installed

AC Drive Power (kW)	Rated Voltage (V)	Cable Length Threshold (m)
4	200-500	50
5.5	200-500	70
7.5	200-500	100
11	200-500	110
15	200-500	125
18.5	200-500	135
22	200-500	150
≥ 30	280-690	150

The following table lists the recommended manufacturer and models of AC output reactors.

Table 7-4 Recommended manufacturer and models of AC output reactors

AC Drive Model	Rated Output Current (A)	AC Output Reactor Model (Shanghai Eagtop)
Three-phase 380 V, 50/60 Hz		
MD380T0.7GB	2.1	OCL-0005-EISC-E1M4
MD380T1.5GB	3.8	OCL-0005-EISC-E1M4
MD380T2.2GB	5.1	OCL-0007-EISC-E1M0
MD380T3.7GB	9	OCL-0010-EISC-EM70
MD380T5.5GB	13	OCL-0015-EISC-EM47
MD380T7.5GB	17	OCL-0020-EISC-EM35
MD380T11GB	25	OCL-0030-EISC-EM23
MD380T15GB	32	OCL-0040-EISC-EM18
MD380T18.5G	37	OCL-0050-EISC-EM14
MD380T22G	45	OCL-0060-EISC-EM12
MD380T30G	60	OCL-0080-EISC-E87U
MD380T37G	75	OCL-0090-EISC-E78U
MD380T45G	91	OCL-0120-EISC-E58U
MD380T55G	112	OCL-0150-EISH-E47U
MD380T75G	150	OCL-0200-EISH-E35U
MD380T90G	176	OCL-0200-EISH-E35U
MD380T110G	210	OCL-0250-EISH-E28U
MD380T132G	253	OCL-0290-EISH-E24U
MD380T160G	304	OCL-0330-EISH-E21U
MD380T200G	377	OCL-0490-EISH-E14U
MD380T220G	426	OCL-0490-EISH-E14U
MD380T250G	465	OCL-0530-EISH-E13U
MD380T280G	520	OCL-0600-EISH-E12U
MD380T315G	585	OCL-0660-EISH-E4U0
MD380T355G	650	OCL-0800-EISH-E5U0

AC Drive Model	Rated Output Current (A)	AC Output Reactor Model (Shanghai Eagtop)
MD380T400G	725	OCL-0800-EISH-E5U0
Three-phase 480 V, 50/60 Hz		
MD380-5T0.7GB	2.1	OCL-0005-EISC-E1M4
MD380-5T1.5GB	3.8	OCL-0005-EISC-E1M4
MD380-5T2.2GB	5.1	OCL-0007-EISC-E1M0
MD380-5T3.7GB	9	OCL-0010-EISC-EM70
MD380-5T5.5GB	13	OCL-0015-EISC-EM47
MD380-5T7.5GB	17	OCL-0020-EISC-EM35
MD380-5T11GB	25	OCL-0030-EISC-EM23
MD380-5T15GB	32	OCL-0040-EISC-EM18
MD380-5T18.5G	37	OCL-0050-EISC-EM14
MD380-5T22G	45	OCL-0060-EISC-EM12
MD380-5T30G	60	OCL-0080-EISC-E87U
MD380-5T37G	75	OCL-0090-EISC-E78U
MD380-5T45G	91	OCL-0120-EISC-E58U
MD380-5T55G	112	OCL-0150-EISH-E47U
MD380-5T75G	150	OCL-0200-EISH-E35U
MD380-5T90G	176	OCL-0200-EISH-E35U
MD380-5T110G	210	OCL-0250-EISH-E28U
MD380-5T132G	253	OCL-0290-EISH-E24U
MD380-5T160G	304	OCL-0330-EISH-E21U
MD380-5T200G	377	OCL-0490-EISH-E14U
MD380-5T220G	426	OCL-0490-EISH-E14U
MD380-5T250G	465	OCL-0530-EISH-E13U
MD380-5T280G	520	OCL-0600-EISH-E12U
MD380-5T315G	585	OCL-0660-EISH-E4U0
MD380-5T355G	650	OCL-0800-EISH-E5U0
MD380-5T400G	725	OCL-0800-EISH-E5U0
Three-phase 690 V, 50/60 Hz		
MD380-7T55G	65	ACL-0080-EISC-EM19B
MD380-7T75G	86	OCL-0080-EISC-E87U
MD380-7T90G	100	OCL-0120-EISC-E58U
MD380-7T110G	120	OCL-0150-EISH-E47U
MD380-7T132G	150	OCL-0200-EISH-E35U
MD380-7T160G	175	OCL-0200-EISH-E35U
MD380-7T200G	215	OCL-0250-EISH-E28U
MD380-7T220G	245	OCL-0290-EISH-E24U
MD380-7T250G	260	OCL-0290-EISH-E24U
MD380-7T280G	299	OCL-0330-EISH-E21U
MD380-7T315G	330	OCL-0390-EISH-E18U

AC Drive Model	Rated Output Current (A)	AC Output Reactor Model (Shanghai Eagtop)
MD380-7T355G	374	OCL-0490-EISH-E14U
MD380-7T400G	410	OCL-0490-EISH-E14U
MD380-7T450G	465	OCL-0530-EISH-E13U
MD380-7T500G	550	OCL-0600-EISH-E12U

7.4 Shielded Cable

7.4.1 Requirements for Shielded Cable

The shielded cable must be used to satisfy the EMC requirements of CE marking. Shielded cables are classified into three-conductor cable and four-conductor cable. If conductivity of the cable shield is not sufficient, add an independent PE cable, or use a four-conductor cable, of which one phase conductor is PE cable.

The three-conductor cable and four-conductor cable are shown in the following figure.

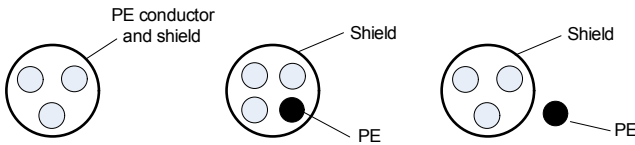

To suppress emission and conduction of the radio frequency interference effectively, the shield of the shielded cable is copper braid. The braided density of the copper braid should be greater than 90% to enhance the shielding efficiency and conductivity, as shown in the following figure.

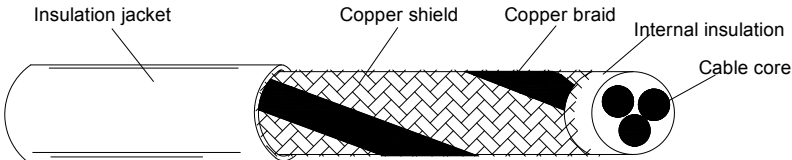

The following figure shows the grounding method of the shielded cable.

Figure 7-1 Grounding of the shielded cable

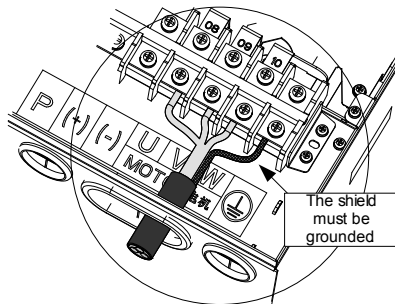

The installation precautions are as follows:

- Symmetrical shielded cable is recommended. The four-conductor shielded cable can also be used as an input cable.
- The motor cable and PE shielded conducting wire (twisted shielded) should be as short as possible to reduce electromagnetic radiation and external stray current and capacitive current of the cable. If the motor cable is over 100 meters long, an output filter or reactor is required.
- It is recommended that all control cables be shielded.
- It is recommended that a shielded cable be used as the output power cable of the AC drive; the cable shield must be well grounded. For devices suffering from interference, shielded twisted pair (STP) cable is recommended as the lead wire and the cable shield must be well grounded.

7.4.2 Cabling Requirements

- 1) The motor cables must be laid far away from other cables. The motor cables of several AC drives can be laid side by side.
- 2) It is recommended that the motor cables, power input cables and control cables be laid in different ducts. To avoid electromagnetic interference caused by rapid change of the output voltage of the AC drive, the motor cables and other cables must not be laid side by side for a long distance.
- 3) If the control cable must run across the power cable, make sure they are arranged at an angle of close to 90°. Other cables must not run across the AC drive.
- 4) The power input and output cables of the AC drive and weak-current signal cables (such as control cable) should be laid vertically (if possible) rather than in parallel.
- 5) The cable ducts must be in good connection and well grounded. Aluminium ducts can be used to improve electric potential.
- 6) The filter, AC drive and motor should be connected to the system (machinery or appliance) properly, with spraying protection at the installation part and conductive metal in full contact.

Figure 7-2 Cabling diagram

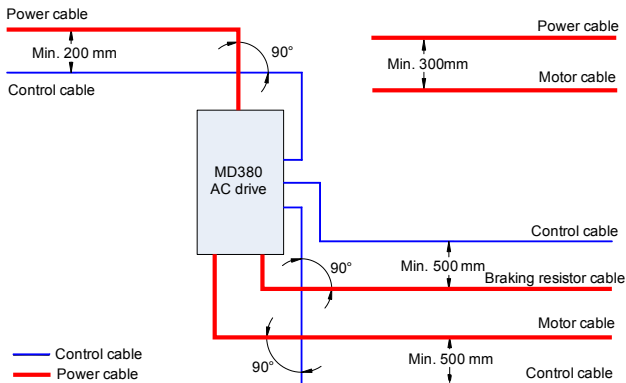

7.5 Solutions to Common EMC Interference Problems

The AC drive generates very strong interference. Although EMC measures are taken, the interference may still exist due to improper cabling or grounding during use. When the AC drive interferes with other devices, adopt the following solutions.

Interference Type	Solution
Leakage protection switch tripping	<ul style="list-style-type: none"> • Connect the motor housing to the PE of the AC drive. • Connect the PE of the AC drive to the PE of the mains power supply. • Add a safety capacitor to the power input cable. • Add magnetic rings to the input drive cable.
AC drive interference during running	<ul style="list-style-type: none"> • Connect the motor housing to the PE of the AC drive. • Connect the PE of the AC drive to the PE of the mains voltage. • Add a safety capacitor to the power input cable and wind the cable with magnetic rings. • Add a safety capacitor to the interfered signal port or wind the signal cable with magnetic rings. • Connect the equipment to the common ground.
Communication interference	<ul style="list-style-type: none"> • Connect the motor housing to the PE of the AC drive. • Connect the PE of the AC drive to the PE of the mains voltage. • Add a safety capacitor to the power input cable and wind the cable with magnetic rings. • Add a matching resistor between the communication cable source and the load side. • Add a common grounding cable besides the communication cable. • Use a shielded cable as the communication cable and connect the cable shield to the common grounding point.
I/O interference	<ul style="list-style-type: none"> • Enlarge the capacitance at the low-speed DI. A maximum of 0.11 uF capacitance is suggested. • Enlarge the capacitance at the AI. A maximum of 0.22 uF is suggested.



Selection and Dimensions

Chapter 8 Selection and Dimensions

8.1 Electrical Specifications of the MD380

Table 8-1 Models and technical data of the MD380

Model	Power Capacity (kVA)	Input Current (A)	Output Current (A)	Adaptable Motor (kW, HP)		Thermal Power Consumption (kW)
Single-phase 220 V, 50/60 Hz						
MD380S0.4GB	1	5.4	2.3	0.4	0.5	0.016
MD380S0.7GB	1.5	8.2	4	0.75	1	0.030
MD380S1.5GB	3	14	7	1.5	2	0.055
MD380S2.2GB	4	23	9.6	2.2	3	0.072
Three-phase 220 V, 50/60 Hz						
MD380-2T0.4GB	1.5	3.4	2.1	0.4	0.5	0.016
MD380-2T0.75GB	3	5	3.8	0.75	1	0.030
MD380-2T1.5GB	4	5.8	5.1	1.5	2	0.055
MD380-2T2.2GB	5.9	10.5	9	2.2	3	0.072
MD380-2T3.7GB	8.9	14.6	13	3.7	5	0.132
MD380-2T5.5GB	17	26	25	5.5	7.5	0.214
MD380-2T7.5GB	21	35	32	7.5	10	0.288
MD380-2T11G	30	46.5	45	11	15	0.489
MD380-2T15G	40	62	60	15	20	0.608
MD380-2T18.5G	57	76	75	18.5	25	0.716
MD380-2T22G	69	92	91	22	30	0.887
MD380-2T30G	85	113	112	30	40	1.11
MD380-2T37G	114	157	150	37	50	1.32
MD380-2T45G	134	180	176	45	60	1.66
MD380-2T55G	160	214	210	55	75	1.98
MD380-2T75G	231	307	304	75	100	2.02
Three-phase 380 V, 50/60 Hz						
MD380T0.7GB	1.5	3.4	2.1	0.75	1	0.027
MD380T1.5GB	3	5	3.8	1.5	2	0.050
MD380T2.2GB	4	5.8	5.1	2.2	3	0.066
MD380T3.7GB	5.9	10.5	9	3.7	5	0.120
MD380T5.5GB	8.9	14.6	13	5.5	7.5	0.195
MD380T7.5GB	11	20.5	17	7.5	10	0.262

Model	Power Capacity (kVA)	Input Current (A)	Output Current (A)	Adaptable Motor (kW, HP)		Thermal Power Consumption (kW)
MD380T11GB	17	26	25	11	15	0.445
MD380T15GB	21	35	32	15	20	0.553
MD380T18.5G	24	38.5	37	18.5	25	0.651
MD380T22G	30	46.5	45	22	30	0.807
MD380T30G	40	62	60	30	40	1.01
MD380T37G	57	76	75	37	50	1.20
MD380T45G	69	92	91	45	60	1.51
MD380T55G	85	113	112	55	75	1.80
MD380T75G	114	157	150	75	100	1.84
MD380T90G	134	180	176	90	125	2.08
MD380T110G	160	214	210	110	150	2.55
MD380T132G	192	256	253	132	200	3.06
MD380T160G	231	307	304	160	250	3.61
MD380T200G	250	385	377	200	300	4.42
MD380T220G	280	430	426	220	300	4.87
MD380T250G	355	468	465	250	400	5.51
MD380T280G	396	525	520	280	370	6.21
MD380T315G	445	590	585	315	500	7.03
MD380T355G	500	665	650	355	420	7.81
MD380T400G	565	785	725	400	530	8.51
Three-phase 480 V, 50/60 Hz						
MD380-5T0.7GB	1.5	3.4	2.1	0.75	1	0.027
MD380-5T1.5GB	3	5	3.8	1.5	2	0.050
MD380-5T2.2GB	4	5.8	5.1	2.2	3	0.066
MD380-5T3.7GB	5.9	10.5	9	3.7	5	0.120
MD380-5T5.5GB	8.9	14.6	13	5.5	7.5	0.195
MD380-5T7.5GB	11	20.5	17	7.5	10	0.262
MD380-5T11GB	17	26	25	11	15	0.445
MD380-5T15GB	21	35	32	15	20	0.553
MD380-5T18.5G	24	38.5	37	18.5	25	0.651
MD380-5T22G	30	46.5	45	22	30	0.807
MD380-5T30G	40	62	60	30	40	1.01
MD380-5T37G	57	76	75	37	50	1.20
MD380-5T45G	69	92	91	45	60	1.51
MD380-5T55G	85	113	112	55	70	1.80

Model	Power Capacity (kVA)	Input Current (A)	Output Current (A)	Adaptable Motor (kW, HP)		Thermal Power Consumption (kW)
MD380-5T75G	114	157	150	75	100	1.84
MD380-5T90G	134	180	176	90	125	2.08
MD380-5T110G	160	214	210	110	150	2.55
MD380-5T132G	192	256	253	132	175	3.06
MD380-5T160G	231	307	304	160	210	3.61
MD380-5T200G	250	385	377	200	260	4.42
MD380-5T220G	280	430	426	220	300	4.87
MD380-5T250G	355	468	465	250	350	5.51
MD380-5T280G	396	525	520	280	370	6.21
MD380-5T315G	445	590	585	315	420	7.03
MD380-5T355G	500	665	650	355	470	7.81
MD380-5T400G	565	785	725	400	530	8.51
Three-phase 690 V, 50/60 Hz						
MD380-7T55G	84	70	65	55	70	1.22
MD380-7T75G	107	90	86	75	100	1.63
MD380-7T90G	125	105	100	90	125	1.96
MD380-7T110G	155	130	120	110	150	2.39
MD380-7T132G	192	170	150	132	175	3.00
MD380-7T160G	231	200	175	160	210	3.32
MD380-7T200G	250	235	215	200	260	4.20
MD380-7T220G	280	247	245	220	300	4.91
MD380-7T250G	355	265	260	250	350	5.08
MD380-7T280G	396	305	299	280	370	5.86
MD380-7T315G	445	350	330	315	420	6.42
MD380-7T355G	500	382	374	355	470	7.38
MD380-7T400G	565	435	410	400	530	7.83
MD380-7T450G	630	490	465	450	600	8.93
MD380-7T500G	700	595	550	500	660	10.76

8.2 Physical Appearance and Overall Dimensions of the MD380

Figure 8-1 Physical appearance and overall dimensions of the MD380 (plastic housing)

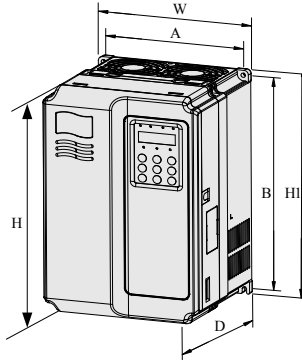

Figure 8-2 Physical appearance and overall dimensions of the MD380 (sheet metal housing)

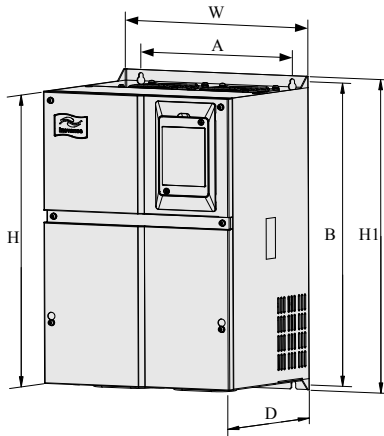

Table 8-2 Overall dimensions and mounting hole dimensions of the MD380

Model	Mounting Hole (mm)		Overall Dimensions (mm)				Mounting Hole Diameter (mm)	Weight (kg)
	A	B	H	H1	W	D		
Single-phase 220 V								
MD380S0.4GB	113	172	186	/	125	164	ø5.0	1.1
MD380S0.7GB								
MD380S1.5GB								
MD380S2.2GB								

Model	Mounting Hole (mm)		Overall Dimensions (mm)				Mounting Hole Diameter (mm)	Weight (kg)
	A	B	H	H1	W	D		
Three-phase 220 V								
MD380-2T0.4GB	113	172	186	/	125	164	ø5.0	1.1
MD380-2T0.75GB								
MD380-2T1.5GB								
MD380-2T2.2GB	148	236	248	/	160	183	ø5.0	2.5
MD380-2T3.7GB								
MD380-2T5.5GB	190	305	322	/	208	192	ø6	6.5
MD380-2T7.5GB								
MD380-2T11G	235	447	432	463	285	228	ø6.5	20
MD380-2T15G								
MD380-2T18.5G	260	580	549	600	385	265	ø10	32
MD380-2T22G								
MD380-2T30G								
MD380-2T37G	343	678	660	700	473	307	ø10	47
MD380-2T45G								
MD380-2T55G	449	903	880	930	579	380	ø10	90
MD380-2T75G								
Three-phase 380 V								
MD380T0.7GB	113	172	186	/	125	164	ø5.0	1.1
MD380T1.5GB								
MD380T2.2GB								
MD380T3.7GB	148	236	248	/	160	183	ø5.0	2.5
MD380T5.5GB								
MD380T7.5GB	190	305	322	/	208	192	ø6	6.5
MD380T11GB								
MD380T15GB								
MD380T18.5G	235	447	432	463	285	228	ø6.5	20
MD380T22G								
MD380T30G								
MD380T37G	260	580	549	600	385	265	ø10	32
MD380T45G								
MD380T55G								

Model	Mounting Hole (mm)		Overall Dimensions (mm)				Mounting Hole Diameter (mm)	Weight (kg)
	A	B	H	H1	W	D		
MD380T75G MD380T90P MD380T90G	343	678	660	700	473	307	∅10	47
MD380T110G MD380T132G MD380T160G	449	903	880	930	579	380	∅10	90
MD380T110GH MD380T132GH MD380T160GH	320	1166	1090	1192	440	310	∅10	90
MD380T200G MD380T220G MD380T250G MD380T280G	420	1030	983	1060	650	377	∅12	130
MD380T315G MD380T355G MD380T400G	520	1300	1203	1358	800	400	∅16	200
Three-phase 480 V								
MD380-5T0.7GB MD380-5T1.5GB MD380-5T2.2GB	113	172	186	/	125	164	∅5.0	1.1
MD380-5T3.7GB MD380-5T5.5GB	148	236	248	/	160	183	∅5.0	2.5
MD380-5T7.5GB MD380-5T11GB MD380-5T15GB	190	305	322	/	208	192	∅6	6.5
MD380-5T18.5G MD380-5T22G MD380-5T30G	235	447	432	463	285	228	∅6.5	20
MD380-5T37G MD380T45G MD380T55G	260	580	549	600	385	265	∅10	32

Model	Mounting Hole (mm)		Overall Dimensions (mm)				Mounting Hole Diameter (mm)	Weight (kg)
	A	B	H	H1	W	D		
MD380-5T75G	343	678	660	700	473	307	ø10	47
MD380-5T90G								
MD380-5T110G	449	903	880	930	579	380	ø10	90
MD380-5T132G								
MD380-5T160G								
MD380-5T200G	420	1030	983	1060	650	377	ø12	130
MD380-5T220G								
MD380-5T250G								
MD380-5T280G								
MD380-5T315G	520	1300	1203	1358	800	400	ø16	200
MD380-5T355G								
MD380-5T400G								
Three-phase 690 V								
MD380-7T55G	250	570	557	600	400	330	ø10	47
MD380-7T75G								
MD380-7T90G								
MD380-7T110G								
MD380-7T132G	320	1166	1090	1192	440	310	ø10	90
MD380-7T160GH								
MD380-7T200GH								
MD380-7T250GH								
MD380-7T280G	420	1030	983	1060	650	377	ø12	130
MD380-7T315G								
MD380-7T355G								
MD380-7T400G	520	1300	1203	1358	800	400	ø16	200
MD380-7T450G								
MD380-7T500G								

8.3 Recommended Cable Diameter and Installation Dimensions of Power Terminals

Note

- The recommended data and models are for reference only. The cable diameter you select cannot be larger than the size in the following figures.
- The prerequisite of cable selection is as follows: Under ambient temperature of 40° C in steady state, for the recommended diameters of the insulation copper conductor or cable, see section 12.4 of the IEC 60204-1-2005

Figure 8-3 Dimensions of power terminals of the MD380 (size B)

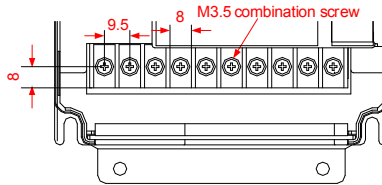

Table 8-3 Recommended cable diameter and cable lug model (size B)

AC Drive Model	Rated Input Current (A)	Recommended Output Power Cable Diameter (mm ²)	Torque of Torque Driver (N.m)	Recommended Cable Lug Model
MD380S0.4GB	5.40	0.75	0.87	TNR0.75-4
MD380S0.7GB	8.20	0.75		TNR0.75-4
MD380S1.5GB	14.00	1.5		TNR1.5-4
MD380S2.2GB	23.00	2.5		GTNR2.5-4
MD380-2T0.4GB	3.40	0.75		TNR0.75-4
MD380-2T0.75GB	5.00	0.75		TNR0.75-4
MD380-2T1.1GB	5.80	0.75		TNR0.75-4
MD380-2T2.2GB	10.50	1.5		TNR1.5-4
MD380T0.7GB	3.40	0.75		TNR0.75-4
MD380T1.5GB	5.00	0.75		TNR0.75-4
MD380T2.2GB	5.80	0.75		TNR0.75-4
MD380-5T0.7GB	3.40	0.75		TNR0.75-4
MD380-5T1.5GB	5.00	0.75		TNR0.75-4
MD380-5T2.2GB	5.80	0.75		TNR0.75-4

Figure 8-4 Dimensions of power terminals of the MD380 (size C)

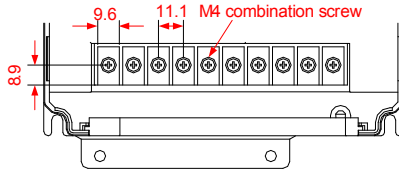

Table 8-4 Recommended cable diameter and cable lug model (size C)

AC Drive Model	Rated Input Current (A)	Recommended Output Power Cable Diameter (mm ²)	Torque of Torque Driver (N.m)	Recommended Cable Lug Model
MD380-2T3.7GB	14.60	2.5	1.2	GTNR2.5-4
MD380-2T5.5GB	26.00	4		TNR4-5
MD380T3.7GB	10.50	1.5		TNR1.5-4
MD380T5.5GB	14.60	2.5		GTNR2.5-4
MD380-5T3.7GB	10.50	1.5		TNR1.5-4
MD380-5T5.5GB	14.60	2.5		GTNR2.5-4

Figure 8-5 Dimensions of power terminals of the MD380 (size D)

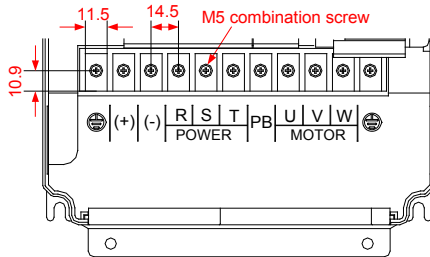

Table 8-5 Recommended cable diameter and cable lug model (size D)

AC Drive Model	Rated Input Current (A)	Recommended Output Power Cable Diameter (mm ²)	Torque of Torque Driver (N.m)	Recommended Cable Lug Model
MD380-2T7.5GB	35.00	6	2.5	GTNR4-5
MD380-2T11G	46.50	10		GTNR10-6
MD380-2T15G	62.00	16		GTNR16-6
MD380T7.5GB	20.50	4		GTNR4-5
MD380T11GB	26.00	4		GTNR6-5
MD380T15GB	35.00	6		GTNR6-5
MD380-5T7.5GB	20.50	4		GTNR4-5
MD380-5T11GB	26.00	4		GTNR6-5
MD380-5T15GB	35.00	6		GTNR6-5

Figure 8-6 Dimensions of power terminals of the MD380 (size E)

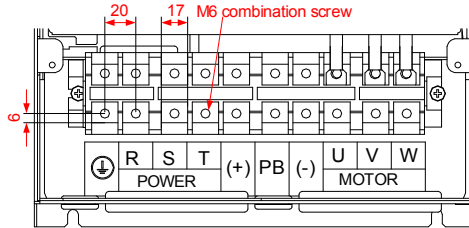

Table 8-6 Recommended cable diameter and cable lug model (size E)

AC Drive Model	Rated Input Current (A)	Recommended Output Power Cable Diameter (mm ²)	Torque of Torque Driver (N.m)	Recommended Cable Lug Model
MD380-2T18.5G	76.00	25	4	GTNR25-6
MD380-2T22G	92.00	35		GTNR35-6
MD380-2T30G	113.00	50		GTNR50-8
MD380T18.5G	38.50	10		GTNR10-6
MD380T22G	46.50	10		GTNR10-6
MD380T30G	62.00	16		GTNR16-6
MD380-5T18.5G	38.50	10		GTNR10-6
MD380-5T22G	46.50	10		GTNR10-6
MD380-5T30G	62.00	16		GTNR16-6

Figure 8-7 Dimensions of power terminals of the MD380 (size F)

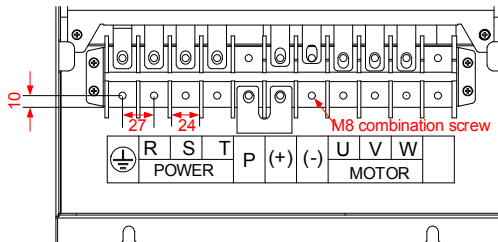

Table 8-7 Recommended cable diameter and cable lug model (size F)

AC Drive Model	Rated Input Current (A)	Recommended Output Power Cable Diameter (mm ²)	Torque of Torque Driver (N.m)	Recommended Cable Lug Model
MD380-2T37G	157.00	70	10.5	GTNR70-8
MD380-2T45G	180.00	95		GTNR95-10
MD380-2T55G	214.00	120		GTNR120-12
MD380T37G	76.00	25		GTNR25-8
MD380T45G	92.00	35		GTNR35-8
MD380T55G	113.00	50		GTNR50-8
MD380-5T37G	76.00	25		GTNR25-8
MD380-5T45G	92.00	35		GTNR35-8
MD380-5T55G	113.00	50		GTNR50-8

Figure 8-8 Dimensions of power terminals of the MD380 (size G)

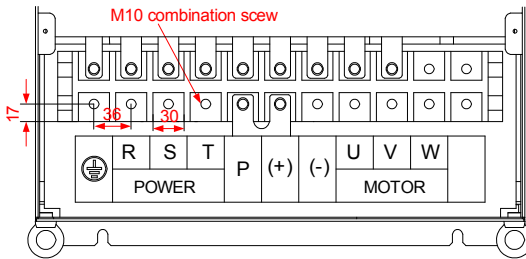

Table 8-8 Recommended cable diameter and cable lug model (size G)

AC Drive Model	Rated Input Current (A)	Recommended Output Power Cable Diameter (mm ²)	Torque of Torque Driver (N.m)	Recommended Cable Lug Model
MD380-2T75G	307.00	150	20	GTNR150-10
MD380T75G	157.00	70		GTNR70-10
MD380T90G	180.00	95		GTNR95-10
MD380-5T75G	157.00	70		GTNR70-10
MD380-5T90G	180.00	95		GTNR95-10

Figure 8-9 Dimensions of power terminals of the MD380 (size H)

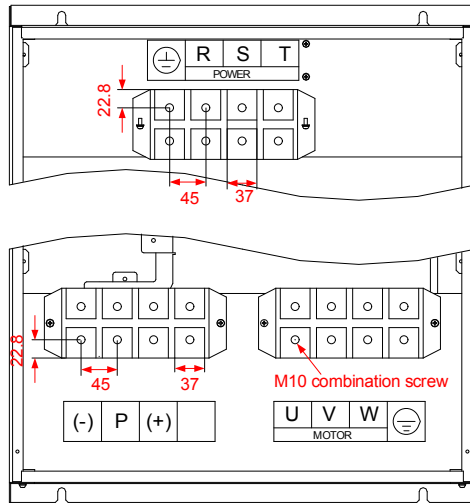

Table 8-9 Recommended cable diameter and cable lug model (size H)

AC Drive Model	Rated Input Current (A)	Recommended Output Power Cable Diameter (mm ²)	Torque of Torque Driver (N.m)	Recommended Cable Lug Model
MD380T110G	214.00	120	20	GTNR120-12
MD380T132G	256.00	120		GTNR120-12
MD380T160G	307.00	150		GTNR150-12
MD380-5T110G	214.00	120		GTNR120-12
MD380-5T132G	256.00	120		GTNR120-12
MD380-5T160G	307.00	150		GTNR150-12

Figure 8-10 Dimensions of power terminals of the MD380 (size I)

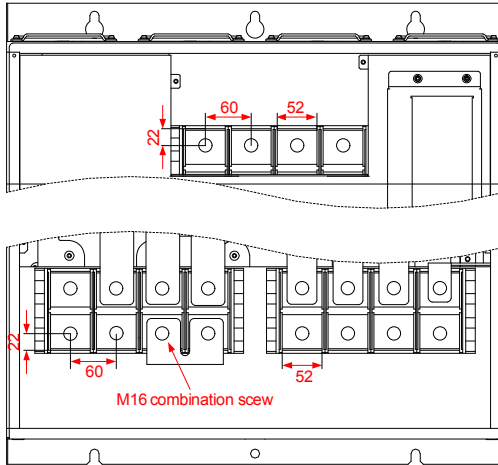

Table 8-10 Recommended cable diameter and cable lug model (size I)

AC Drive Model	Rated Input Current (A)	Recommended Output Power Cable Diameter (mm ²)	Torque of Torque Driver (N.m)	Recommended Cable Lug Model
MD380T200G	385.00	185	85	GTNR185-16
MD380T220G	430.00	240		GTNR240-16
MD380T250G	468.00	120 x 2		GTNR120-16
MD380T280G	525.00	120 x 2		GTNR120-16
MD380T315G	590.00	150 x 2		GTNR150-16
MD380-5T200G	385.00	185		GTNR185-16
MD380-5T220	430.00	240		GTNR240-16
MD380-5T250G	468.00	120 x 2		GTNR120-16
MD380-5T280G	525.00	120 x 2		GTNR120-16
MD380-5T315G	590.00	150 x 2		GTNR150-16

Figure 8-11 Dimensions of power terminals of the MD380 (size J)

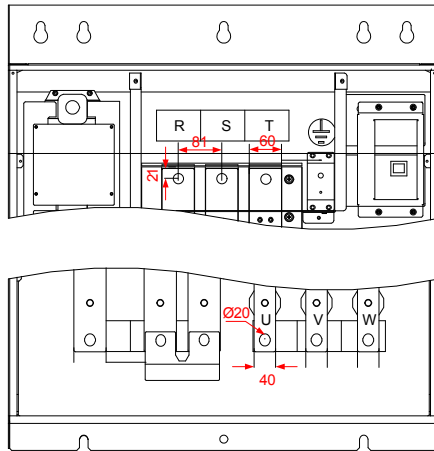

Table 8-11 Recommended cable diameter and cable lug model (size I)

AC Drive Model	Rated Input Current (A)	Recommended Output Power Cable Diameter (mm ²)	Torque of Torque Driver (N.m)	Recommended Cable Lug Model
MD380T355G	665.00	185 x 2	85	GTNR185-16
MD380T400G	785.00	240 x 2		GTNR240-16
MD380-5T355G	665.00	185 x 2		GTNR185-16
MD380-5T400G	785.00	240 x 2		GTNR240-16

Reference information about the recommended cable lug (Suzhou Yuanli Metal Enterprise) is provided in the following part.

The following figure shows appearance of recommended cable lugs

Figure 8-12 Appearance of recommended cable lugs



The following figure shows the dimensions of recommended cable lugs

Figure 8-13 Dimensions of recommended TNR series cable lugs

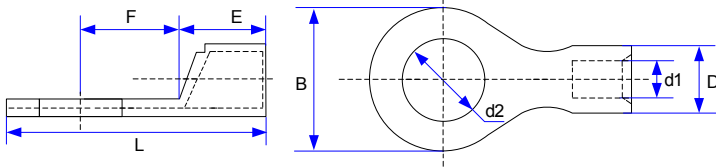

Table 8-12 Models and dimensions of the TNR series cable lugs

Model	Cable Range		D	d1	E	F	B	d2	L	Current A	Crimping Tool
	AWG/MCM	mm ²									
TNR0.75-4	22-16	0.25-1.0	2.8	1.3	4.5	6.6	8.0	4.3	15.0	10	RYO-8
TNR1.25-4	22-16	0.25-1.65	3.4	1.7	4.5	7.3	8	5.3	15.8	19	AK-1M

Figure 8-14 Dimensions of recommended GTNR series cable lugs

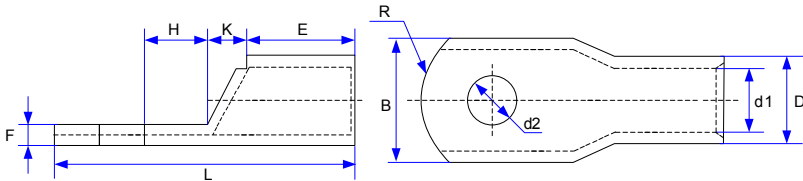

Table 8-13 Models and dimensions of the GTNR series cable lugs

Model	D	d1	E	H	K	B	d2	F	L	R	Crimping Tool
GTNR1.5-5	4.0	2.2	5.0	5.0	2.0	8.0	5.3	1.0	16.0	5	RYO-8 YYT-8 RYO-14
GTNR2.5-4	4.5	2.9	7.0	5.0	2.0	8.0	4.3	1.0	18.0		
GTNR2.5-5				6.0		5.3	20.0				
GTNR2.5-6	10.2	6.4	0.8								
GTNR4-5	5.2	3.6	7.0	6.0	2.0	10.0	5.3	1.0	20.0		
GTNR4-6				6.4							
GTNR6-5	6.0	4.2	9.0	6.0	3.0	10.0	5.3	1.2	23.0		
GTNR6-6				7.5		6.4	26.0				
GTNR6-8						12.0	8.4	1.0			
GTNR10-6	7.0	5.0	9.0	8.0	3.5	12.4	6.4	1.3	26.5		
GTNR10-8						8.4	27.5				
GTNR16-6	7.8	5.8	12.0	8.0	4.0	12.4	6.4	1.3	31.0		
GTNR16-8						8.4					
GTNR25-6	9.5	7.5	12.0	8.0	4.5	14.0	6.4	2.0	32.0		
GTNR25-8				9.0		15.5	8.4	1.6	34.0		
GTNR25-10				10.5		17.5	10.5	1.4	37.0		
GTNR35-6	11.4	8.6	15.0	9.0	5.0	15.5	6.4	2.8	38.0		
GTNR35-8				10.5		8.4					
GTNR35-10						17.5	10.5	2.5	40.5		
GTNR50-8	12.6	9.6	16.0	11.0	6.0	18.0	8.4	2.8	43.5		
GTNR50-10						10.5					
GTNR70-8	15.0	12.0	18.0	13.0	7.0	21.0	8.4	2.8	50.0		
GTNR70-10							10.5				
GTNR70-12							13.0				
GTNR95-10	17.4	13.5	20.0	13.0	9.0	25.0	10.5	3.9	55.0		
GTNR95-12							13.0				
GTNR120-12	19.8	15.0	22.0	14.0	10.0	28.0	13.0	4.7	60.0		
GTNR120-16				16.0			17.0		64.0		
GTNR150-12	21.2	16.5	26.0	16.0	11.0	30.0	13.0	4.7	69.0		
GTNR150-16							17.0				
GTNR185-16	23.5	18.5	32.0	17.0	12.0	34.0	17.0	5.0	78.0		
GTNR240-16	26.5	21.5	38.0	20.0	14.0	38.0	17.0	5.5	92.0		
GTNR240-20							21.0				

8.4 Selection of Peripheral Electrical Devices

Table 8-14 Selection of peripheral electrical devices of the MD380

AC Drive Model	MCCB (A)	Contactora (A)	Cable of Input Side Main Circuit (mm ²)	Cable of Output Side Main Circuit (mm ²)	Cable of Control Circuit (mm ²)
Single-phase 220 V					
MD380S0.4GB	6	9	0.75	0.75	0.5
MD380S0.7GB	10	12	0.75	0.75	0.5
MD380S1.5GB	16	18	1.5	1.5	0.5
MD380S2.2GB	25	25	2.5	2.5	0.5
Three-phase 220 V					
MD380-2T0.4GB	4	9	0.75	0.75	0.5
MD380-2T0.75GB	6	9	0.75	0.75	0.5
MD380-2T1.5GB	10	12	0.75	0.75	0.5
MD380-2T2.2GB	16	18	1.5	1.5	0.5
MD380-2T3.7GB	20	25	2.5	2.5	0.75
MD380-2T5.5GB	32	32	4.0	4.0	0.75
MD380-2T7.5GB	40	40	6.0	6.0	0.75
MD380-2T11G	50	50	10	10	0.75
MD380-2T15G	63	63	16	16	0.75
MD380-2T18.5G	80	80	25	25	1.0
MD380-2T22G	100	115	35	35	1.0
MD380-2T30G	125	125	50	50	1.0
MD380-2T37G	160	185	70	70	1.0
MD380-2T45G	200	225	95	95	1.0
MD380-2T55G	225	225	120	120	10
MD380-2T75G	350	400	150	150	1.0
Three-phase 380 V					
MD380T0.7GB	4	9	0.75	0.75	0.5
MD380T1.5GB	6	9	0.75	0.75	0.5
MD380T2.2GB	10	12	0.75	0.75	0.5
MD380T3.7GB	16	18	1.5	1.5	0.5
MD380T5.5 GB	20	25	2.5	2.5	0.75
MD380T7.5 GB	25	25	4.0	4.0	0.75
MD380T11 GB	32	32	6.0	6.0	0.75
MD380T15GB	40	40	6.0	6.0	0.75
MD380T18.5G	50	50	10	10	1.0
MD380T22G	50	50	10	10	1.0
MD380T30G	63	63	16	16	1.0

AC Drive Model	MCCB (A)	Contactor (A)	Cable of Input Side Main Circuit (mm ²)	Cable of Output Side Main Circuit (mm ²)	Cable of Control Circuit (mm ²)
MD380T37G	80	80	25	25	1.0
MD380T45G	100	115	35	35	1.0
MD380T55G	125	125	50	50	1.0
MD380T75G	160	185	70	70	1.0
MD380T90G	200	225	95	95	1.0
MD380T110G	225	225	120	120	1.0
MD380T132G	315	330	120	120	1.0
MD380T160G	350	400	150	150	1.0
MD380T200G	400	400	185	185	1.0
MD380T220G	500	500	240	240	1.0
MD380T250G	500	500	120 x 2	120 x 2	1.0
MD380T280G	630	630	120 x 2	120 x 2	1.0
MD380T315G	630	630	150 x 2	150 x 2	1.0
MD380T355G	700	800	185 x 2	185 x 2	1.0
MD380T400G	800	800	240 x 2	240 x 2	1.0
Three-phase 480 V					
MD380-5T0.7GB	4	9	0.75	0.75	0.5
MD380-5T1.5GB	6	9	0.75	0.75	0.5
MD380-5T2.2GB	10	12	0.75	0.75	0.5
MD380-5T3.7GB	16	18	1.5	1.5	0.5
MD380-5T5.5GB	20	25	2.5	2.5	0.75
MD380-5T7.5GB	25	25	4.0	4.0	0.75
MD380-5T11GB	32	32	4.0	4.0	0.75
MD380-5T15GB	40	40	6.0	6.0	0.75
MD380-5T18.5G	50	50	10	10	1.0
MD380-5T22G	50	50	10	10	1.0
MD380-5T30G	63	63	16	16	1.0
MD380-5T37G	80	80	25	25	1.0
MD380-5T45G	100	115	35	35	1.0
MD380-5T55G	125	125	50	50	1.0
MD380-5T75G	160	185	70	70	1.0
MD380-5T90G	200	225	95	95	1.0
MD380-5T110G	225	225	120	120	1.0
MD380-5T132G	315	330	120	120	1.0
MD380-5T160G	350	400	150	150	1.0
MD380-5T200G	400	400	185	185	1.0
MD380-5T220G	500	500	240	240	1.0

AC Drive Model	MCCB (A)	Contactora (A)	Cable of Input Side Main Circuit (mm ²)	Cable of Output Side Main Circuit (mm ²)	Cable of Control Circuit (mm ²)
MD380-5T250G	500	500	120 x 2	120 x 2	1.0
MD380-5T280G	630	630	120 x 2	120 x 2	1.0
MD380-5T315G	630	630	150 x 2	150 x 2	1.0
MD380-5T355G	700	800	185 x 2	185 x 2	1.0
MD380-5T400G	800	800	240 x 2	240 x 2	1.0
Three-phase 690 V					
MD380-7T55G	80	80	16	16	1.0
MD380-7T75G	100	115	25	25	1.0
MD380-7T90G	125	125	35	35	1.0
MD380-7T110G	160	185	50	50	1.0
MD380-7T132G	180	200	70	70	1.0
MD380-7T160G	225	225	95	95	1.0
MD380-7T200G	250	250	120	120	1.0
MD380-7T220G	315	315	120	120	1.0
MD380-7T250G	315	315	150	150	1.0
MD380-7T280G	350	400	150	150	1.0
MD380-7T315G	400	400	185	185	1.0
MD380-7T355G	400	400	185	185	1.0
MD380-7T400G	500	500	240	240	1.0
MD380-7T450G	630	630	120 x 2	120 x 2	1.0
MD380-7T500G	630	630	150 x 2	150 x 2	1.0

8.5 Selection and Installation of External DC Reactor

8.5.1 Installation Mode of External DC Reactor

The MD380 series AC drives of over 75 kW power (2T is 37 kW) are configured with an external DC reactor as standard. The DC reactor is packed in separate wooden box for delivery.

When installing the DC reactor, remove the shorting copper busbar between the main circuit connection terminals P and +. Then connect the DC reactor between terminals P and + (no polarity requirement). The copper busbar is not used any longer after the installation is complete.

Note

Customized models can be provided for special requirements.

8.5.2 Physical Dimensions of External DC Reactor

Figure 8-15 Physical dimensions of external DC reactor

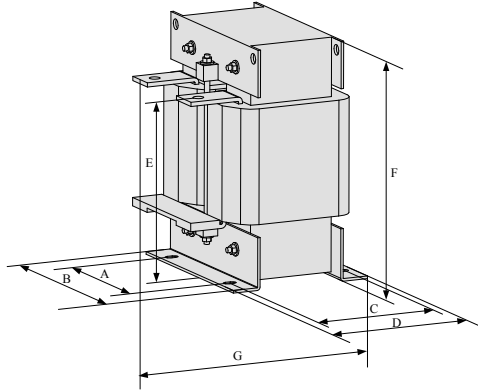

Table 8-15 Adaptable AC drive models

Adaptable AC Drive Model	A	B	C	D	E	F	G	Fixed Hole	Diameter of the Hole for Connecting Copper Busbar	Reactor Model
MD380-2T37G/45G	160	190	125	161	192	255	195	10 x 15	ø12	DCL-0200
MD380T75G/90G										
MD380-5T75G/90G										
MD380-2T55G	160	190	125	161	192	255	195	10 x 15	ø12	DCL-0250
MD380T/110G/132P										
MD380-5T/110G/132P										
MD380-2T75G	160	190	125	161	192	255	195	10 x 15	ø12	DCL-0360
MD380T132G/160G										
MD380-5T132G/160G										
MD380T200G/220G	190	230	93	128	250	325	200	13 x 18	ø15	DCL-0600
MD380-5T/200G/220G										
MD380T250G/280G	190	230	93	128	250	325	200	13 x 18	ø15	DCL-0700
MD380-5T250G/280G										
MD380T315G/355G/400G	224	250	135	165	260	330	235	12 x 20	ø14	DCL-1000
MD380-5T315G/355G/400G										
MD380-7T55G/75G/90G	160	190	125	161	192	255	195	10 x 15	ø12	Not configured with reactor now
MD380-7T110G/132G										

Adaptable AC Drive Model	A	B	C	D	E	F	G	Fixed Hole	Diameter of the Hole for Connecting Copper Busbar	Reactor Model
MD380-7T160GH/200GH	160	190	125	161	192	255	195	10 x 15	ø12	DCL-0250
MD380-7T220GH/250GH	160	190	125	161	192	255	195	10 x 15	ø12	DCL-0360
MD380-7T280G/315G/355G										
MD380-7T400G/450G/500G	190	230	93	128	250	325	200	13 x 18	ø15	DCL-0700

8.6 Physical Dimensions of External Operation Panel

Figure 8-16 Physical dimensions of external operation panel

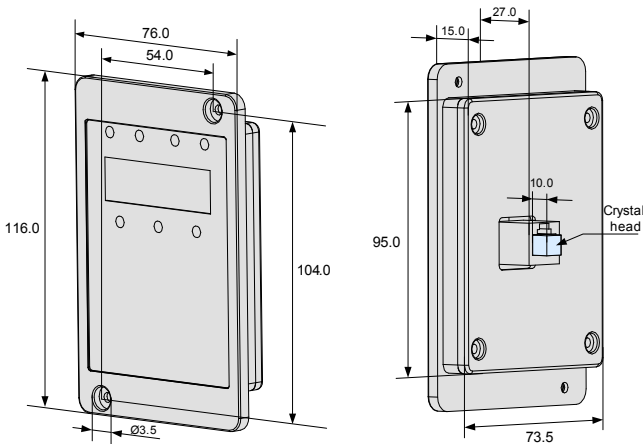

8.7 Selection of Braking Unit and Braking Resistor

8.7.1 Physical Dimensions of External DC Reactor

The motor and load's regenerative energy is almost completely consumed on the braking resistor when braking.

According to the formula $U \times U/R = P_b$:

- U refers to the braking voltage at system stable braking.

Different systems select different braking voltages. The 380 VAC system usually selects 700 V braking voltage.

- P_b refers to the braking power.

8.7.2 Selection of Power of Braking Resistor

In theory, the power of the braking resistor is consistent with the braking power. But in consideration that the de-rating is 70%, you can calculate the power of the braking resistor according to the formula $0.7 \times Pr = Pb \times D$.

- Pr refers to the power of resistor.
- D refers to the braking frequency (percentage of the regenerative process to the whole working process)

Application	Elevator	Winding and unwinding	Centrifuge	Occasional braking load	General application
Braking Frequency	20%–30%	20%–30%	50%–60%	5%	10%

Table 8-14 below provides data for reference. You can select different resistance and power based on actual needs. However, the resistance must not be lower than the recommended value. The power may be higher than the recommended value.

The braking resistor model is dependent on the generation power of the motor in the actual system and is also related to the system inertia, deceleration time and potential energy load. For systems with high inertia, and/or rapid deceleration times, or frequent braking sequences, the braking resistor with higher power and lower resistance value should be selected.

Table 8-16 Recommended values of braking resistor

Model	Recommended Power	Recommended Resistance	Braking Unit	Remark
Single-phase 220 V				
MD380S0.4GB	80 W	$\geq 200 \Omega$	Built-in (standard)	No special description
MD380S0.7GB	80 W	$\geq 150 \Omega$		
MD380S1.5GB	100 W	$\geq 100 \Omega$		
MD380S2.2GB	100 W	$\geq 70 \Omega$		
Three-phase 220 V				
MD380-2T0.4GB	150 W	$\geq 150 \Omega$	Built-in (standard)	No special description
MD380-2T0.75GB	150 W	$\geq 110 \Omega$		
MD380-2T1.1GB	250 W	$\geq 100 \Omega$		
MD380-2T2.2GB	300 W	$\geq 65 \Omega$		
MD380-2T3.7GB	400 W	$\geq 45 \Omega$		
MD380-2T5.5GB	800 W	$\geq 22 \Omega$		
MD380-2T7.5GB	1000 W	$\geq 16 \Omega$	Built-in (optional)	Add "B" to the model if a braking unit is needed.
MD380-2T11G	1500 W	$\geq 11 \Omega$		
MD380-2T15G	2500 W	$\geq 8 \Omega$	External	MDBUN-45-S
MD380-2T18.5G	3.7 kW	$\geq 8.0 \Omega$		
MD380-2T22G	4.5 kW	$\geq 8 \Omega$		
MD380-2T30G	5.5 kW	$\geq 4 \Omega$		
MD380-2T37G	7.5 kW	$\geq 4 \Omega$		
MD380-2T45G	4.5 kW x 2	$\geq 4 \Omega \times 2$		

Model	Recommended Power	Recommended Resistance	Braking Unit	Remark
MD380-2T55G	5.5 kW x 2	$\geq 4 \Omega \times 2$	External	MDBUN-60-S x 2
MD380-2T75G	16 kW	$\geq 1.2 \Omega$	External	MDBUN-90-S x 2
Three-phase 380 V				
MD380T0.7GB	150 W	$\geq 300 \Omega$	Built-in (standard)	No special description
MD380T1.5GB	150 W	$\geq 220 \Omega$		
MD380T2.2GB	250 W	$\geq 200 \Omega$		
MD380T3.7GB	300 W	$\geq 130 \Omega$		
MD380T5.5GB	400 W	$\geq 90 \Omega$		
MD380T7.5GB	500 W	$\geq 65 \Omega$		
MD380T11GB	800 W	$\geq 43 \Omega$		
MD380T15GB	1000 W	$\geq 32 \Omega$	Built-in (optional)	Add "B" to the model if a braking unit is needed.
MD380T22G	1500 W	$\geq 22 \Omega$		
MD380T30G	2500 W	$\geq 16 \Omega$		
MD380T37G	3.7 kW	$\geq 16.0 \Omega$	External	MDBUN-45-T
MD380T45G	4.5 kW	$\geq 16 \Omega$	External	MDBUN-60-T
MD380T55G	5.5 kW	$\geq 8 \Omega$	External	MDBUN-60-T
MD380T75G	7.5 kW	$\geq 8 \Omega$	External	MDBUN-90-T
MD380T90G	4.5 kW x 2	$\geq 8 \Omega \times 2$	External	MDBUN-60-T x 2
MD380T110G	5.5 kW x 2	$\geq 8 \Omega \times 2$	External	MDBUN-60-T x 2
MD380T132G	6.5 kW x 2	$\geq 8 \Omega \times 2$	External	MDBUN-90-T x 2
MD380T160G	16 kW	$\geq 2.5 \Omega$	External	MDBUN-90-T x 2
MD380T200G	20 kW	$\geq 2.5 \Omega$	External	MDBU-200-B
MD380T220G	22 kW	$\geq 2.5 \Omega$	External	MDBU-200-B
MD380T250G	12.5 kW x 2	$\geq 2.5 \Omega \times 2$	External	MDBU-200-B x 2
MD380T280G	14 kW x 2	$\geq 2.5 \Omega \times 2$	External	MDBU-200-B x 2
MD380T315G	16 kW x 2	$\geq 2.5 \Omega \times 2$	External	MDBU-200-B x 2
MD380T355G	17 kW x 2	$\geq 2.5 \Omega \times 2$	External	MDBU-200-B x 2
MD380T400G	14 kW x 3	$\geq 2.5 \Omega \times 3$	External	MDBU-200-B x 3
Three-phase 480 V				
MD380-5T0.7GB	150 W	$\geq 300 \Omega$	Built-in (standard)	No special description
MD380-5T1.5GB	150 W	$\geq 220 \Omega$		
MD380-5T2.2GB	250 W	$\geq 200 \Omega$		
MD380-5T3.7GB	300 W	$\geq 130 \Omega$		
MD380-5T5.5GB	400 W	$\geq 90 \Omega$		
MD380-5T7.5GB	500 W	$\geq 65 \Omega$		
MD380-5T11GB	800 W	$\geq 43 \Omega$		
MD380-5T15GB	1000 W	$\geq 32 \Omega$	Built-in (optional)	Add "B" to the model if a braking unit is needed.
MD380-5T18.5G	1300 W	$\geq 25 \Omega$		
MD380-5T22G	1500 W	$\geq 22 \Omega$		
MD380-5T30G	2500 W	$\geq 16 \Omega$		

Model	Recommended Power	Recommended Resistance	Braking Unit	Remark
MD380-5T37G	3.7 kW	$\geq 16.0 \Omega$	External	MDBUN-45-5T
MD380-5T45G	4.5 kW	$\geq 16 \Omega$	External	MDBUN-45-5T
MD380-5T55G	5.5 kW	$\geq 8 \Omega$	External	MDBUN-60-5T
MD380-5T75G	7.5 kW	$\geq 8 \Omega$	External	MDBUN-90-5T
MD380-5T90G	4.5 kW x 2	$\geq 8 \Omega \times 2$	External	MDBUN-90-5T
MD380-5T110G	5.5 kW x 2	$\geq 8 \Omega \times 2$	External	MDBUN-60-5T x 2
MD380-5T132G	6.5 kW x 2	$\geq 8 \Omega \times 2$	External	MDBUN-90-5T x 2
MD380-5T160G	16 kW	$\geq 2.5 \Omega$	External	MDBUN-90-5T x 2
MD380-5T200G	20 kW	$\geq 2.5 \Omega$	External	MDBU-200-D
MD380-5T220G	22 kW	$\geq 2.5 \Omega$	External	MDBU-200-D
MD380-5T250G	12.5 kW x 2	$\geq 2.5 \Omega \times 2$	External	MDBU-200-D x 2
MD380-5T280G	14 kW x 2	$\geq 2.5 \Omega \times 2$	External	MDBU-200-D x 2
MD380-5T315G	16 kW x 2	$\geq 2.5 \Omega \times 2$	External	MDBU-200-D x 2
MD380-5T355G	17 kW x 2	$\geq 2.5 \Omega \times 2$	External	MDBU-200-D x 2
MD380-5T400G	14 kW x 3	$\geq 2.5 \Omega \times 3$	External	MDBU-200-D x 3

Note

- " x 2" indicates that two braking units with their respective braking resistor are connected in parallel.
- " x 3" means the same.



Maintenance and Troubleshooting

Chapter 9 Maintenance and Troubleshooting

9.1 Routine Repair and Maintenance of the MD380

9.1.1 Routine Maintenance

The influence of the ambient temperature, humidity, dust and vibration will cause the aging of the devices in the AC drive, which may cause potential faults or reduce the service life of the AC drive. Therefore, it is necessary to carry out routine and periodic maintenance.

Routine maintenance involves checking:

- Whether the motor sounds abnormally during running
- Whether the motor vibrates excessively during running
- Whether the installation environment of the AC drive changes.
- Whether the AC drive's cooling fan works normally
- Whether the AC drive overheats

Routine cleaning involves:

- Keep the AC drive clean all the time.
- Remove the dust, especially metal powder on the surface of the AC drive, to prevent the dust from entering the AC drive.
- Clear the oil stain on the cooling fan of the AC drive.

9.1.2 Periodic Inspection

Perform periodic inspection in places where inspection is difficult.

Periodic inspection involves:

Check and clean the air duct periodically.

Check whether the screws become loose.

Check whether the AC drive is corroded.

Check whether the wiring terminals show signs of arcing;

Main circuit insulation test

Prompt

Before measuring the insulating resistance with megameter (500 VDC megameter recommended), disconnect the main circuit from the AC drive. Do not use the insulating resistance meter to test the insulation of the control circuit. The high voltage test need not be performed again because it has been completed before delivery.

9.1.3 Replacement of Vulnerable Components

The vulnerable components of the AC drive are cooling fan and filter electrolytic capacitor. Their service life is related to the operating environment and maintenance status. Generally, the service life is shown as follows:

Component	Service Life	Possible Damage Reason	Judging Criteria
Fan	2 to 3 years	<ul style="list-style-type: none"> Bearing worn Blade aging 	<ul style="list-style-type: none"> Whether there is crack on the blade Whether there is abnormal vibration noise upon startup
Electrolytic capacitor	4 to 5 years	<ul style="list-style-type: none"> Input power supply in poor quality High ambient temperature Frequent load jumping Electrolytic aging 	<ul style="list-style-type: none"> Whether there is liquid leakage. Whether the safe valve has projected. Measure the static capacitance. Measure the insulating resistance.

9.1.4 Storage of the AC Drive

For storage of the AC drive, pay attention to the following two aspects:

- 1) Pack the AC drive with the original packing box provided by Inovance.
- 2) Long-term storage degrades the electrolytic capacitor. Thus, the AC drive must be energized once every 2 years, each time lasting at least 5 hours. The input voltage must be increased slowly to the rated value with the regulator.

9.2 Warranty Agreement

- 1) Free warranty only applies to the AC drive itself.
- 2) Inovance will provide 18-month warranty (starting from the leave-factory date as indicated on the barcode) for the failure or damage under normal use conditions. If the equipment has been used for over 18 months, reasonable repair expenses will be charged.
- 3) Reasonable repair expenses will be charged for the damages due to the following causes:
 - Improper operation without following the instructions
 - Fire, flood or abnormal voltage.
 - Using the AC drive for non-recommended function
- 4) The maintenance fee is charged according to Inovance's uniform standard. If there is an agreement, the agreement prevails.

9.3 Faults and Solutions

The MD380 provides a total of 24 pieces of fault information and protective functions. After a fault occurs, the AC drive implements the protection function, and displays the fault code on the operation panel (if the operation panel is available).

Before contacting Inovance for technical support, you can first determine the fault type, analyze the causes, and perform troubleshooting according to the following tables. If the fault cannot be rectified, contact the agent or Inovance.

Err22 is the AC drive hardware overcurrent or overvoltage signal. In most situations, hardware overvoltage fault causes Err22.

Figure 9-1 Solutions to the faults of the MD380

Fault Name	Display	Possible Causes	Solutions
Inverter unit protection	Err01	<ol style="list-style-type: none"> 1: The output circuit is grounded or short circuited. 2: The connecting cable of the motor is too long. 3: The module overheats. 4: The internal connections become loose. 5: The main control board is faulty. 6: The drive board is faulty. 7: The inverter module is faulty. 	<ol style="list-style-type: none"> 1: Eliminate external faults. 2: Install a reactor or an output filter. 3: Check the air filter and the cooling fan. 4: Connect all cables properly. 5: Contact the agent or Inovance.
Overcurrent during acceleration	Err02	<ol style="list-style-type: none"> 1: The output circuit is grounded or short circuited. 2: Motor auto-tuning is not performed. 3: The acceleration time is too short. 4: Manual torque boost or V/F curve is not appropriate. 5: The voltage is too low. 6: The startup operation is performed on the rotating motor. 7: A sudden load is added during acceleration. 8: The AC drive model is of too small power class. 	<ol style="list-style-type: none"> 1: Eliminate external faults. 2: Perform the motor auto-tuning. 3: Increase the acceleration time. 4: Adjust the manual torque boost or V/F curve. 5: Adjust the voltage to normal range. 6: Select rotational speed tracking restart or start the motor after it stops. 7: Remove the added load. 8: Select an AC drive of higher power class.
Overcurrent during deceleration	Err03	<ol style="list-style-type: none"> 1: The output circuit is grounded or short circuited. 2: Motor auto-tuning is not performed. 3: The deceleration time is too short. 4: The voltage is too low. 5: A sudden load is added during deceleration. 6: The braking unit and braking resistor are not installed. 	<ol style="list-style-type: none"> 1: Eliminate external faults. 2: Perform the motor auto-tuning. 3: Increase the deceleration time. 4: Adjust the voltage to normal range. 5: Remove the added load. 6: Install the braking unit and braking resistor.

Fault Name	Display	Possible Causes	Solutions
Overcurrent at constant speed	Err04	<ol style="list-style-type: none"> 1: The output circuit is grounded or short circuited. 2: Motor auto-tuning is not performed. 3: The voltage is too low. 4: A sudden load is added during operation. 5: The AC drive model is of too small power class. 	<ol style="list-style-type: none"> 1: Eliminate external faults. 2: Perform the motor auto-tuning. 3: Adjust the voltage to normal range. 4: Remove the added load. 5: Select an AC drive of higher power class.
Overvoltage during acceleration	Err05	<ol style="list-style-type: none"> 1: The input voltage is too high. 2: An external force drives the motor during acceleration. 3: The acceleration time is too short. 4: The braking unit and braking resistor are not installed. 	<ol style="list-style-type: none"> 1: Adjust the voltage to normal range. 2: Cancel the external force or install a braking resistor. 3: Increase the acceleration time. 4: Install the braking unit and braking resistor.
Overvoltage during deceleration	Err06	<ol style="list-style-type: none"> 1: The input voltage is too high. 2: An external force drives the motor during deceleration. 3: The deceleration time is too short. 4: The braking unit and braking resistor are not installed. 	<ol style="list-style-type: none"> 1: Adjust the voltage to normal range. 2: Cancel the external force or install the braking resistor. 3: Increase the deceleration time. 4: Install the braking unit and braking resistor.
Overvoltage at constant speed	Err07	<ol style="list-style-type: none"> 1: The input voltage is too high. 2: An external force drives the motor during deceleration. 	<ol style="list-style-type: none"> 1: Adjust the voltage to normal range. 2: Cancel the external force or install the braking resistor.
Control power supply fault	Err08	The input voltage is not within the allowable range.	Adjust the input voltage to the allowable range.
Undervoltage	Err09	<ol style="list-style-type: none"> 1: Instantaneous power failure occurs on the input power supply. 2: The AC drive's input voltage is not within the allowable range. 3: The bus voltage is abnormal. 4: The rectifier bridge and buffer resistor are faulty. 5: The drive board is faulty. 6: The main control board is faulty. 	<ol style="list-style-type: none"> 1: Reset the fault. 2: Adjust the voltage to normal range. 3: Contact the agent or Inovance.
AC drive overload	Err10	<ol style="list-style-type: none"> 1: The load is too heavy or locked-rotor occurs on the motor. 2: The AC drive model is of too small power class. 	<ol style="list-style-type: none"> 1: Reduce the load and check the motor and mechanical condition. 2: Select an AC drive of higher power class.

Fault Name	Display	Possible Causes	Solutions
Motor overload	Err11	<ol style="list-style-type: none"> 1: F9-01 is set improperly. 2: The load is too heavy or locked-rotor occurs on the motor. 3: The AC drive model is of too small power class. 	<ol style="list-style-type: none"> 1: Set F9-01 correctly. 2: Reduce the load and check the motor and the mechanical condition. 3: Select an AC drive of higher power class.
Power input phase loss	Err12	<ol style="list-style-type: none"> 1: The three-phase power input is abnormal. 2: The drive board is faulty. 3: The lightning board is faulty. 4: The main control board is faulty. 	<ol style="list-style-type: none"> 1: Eliminate external faults. 2: Contact the agent or Inovance.
Power output phase loss	Err13	<ol style="list-style-type: none"> 1: The cable connecting the AC drive and the motor is faulty. 2: The AC drive's three-phase outputs are unbalanced when the motor is running. 3: The drive board is faulty. 4: The module is faulty. 	<ol style="list-style-type: none"> 1: Eliminate external faults. 2: Check whether the motor three-phase winding is normal. 3: Contact the agent or Inovance.
Module overheat	Err14	<ol style="list-style-type: none"> 1: The ambient temperature is too high. 2: The air filter is blocked. 3: The fan is damaged. 4: The thermally sensitive resistor of the module is damaged. 5: The inverter module is damaged. 	<ol style="list-style-type: none"> 1: Lower the ambient temperature. 2: Clean the air filter. 3: Replace the damaged fan. 4: Replace the damaged thermally sensitive resistor. 5: Replace the inverter module.
External equipment fault	Err15	<ol style="list-style-type: none"> 1: External fault signal is input via DI. 2: External fault signal is input via virtual I/O. 	Reset the operation.
Communication fault	Err16	<ol style="list-style-type: none"> 1: The host computer is in abnormal state. 2: The communication cable is faulty. 3: F0-28 is set improperly. 4: The communication parameters in group FD are set improperly. 	<ol style="list-style-type: none"> 1: Check the cabling of host computer. 2: Check the communication cabling. 3: Set F0-28 correctly. 4: Set the communication parameters properly.
Contacting fault	Err17	<ol style="list-style-type: none"> 1: The drive board and power supply are faulty. 2: The contactor is faulty. 	<ol style="list-style-type: none"> 1: Replace the faulty drive board or power supply board. 2: Replace the faulty contactor.

Fault Name	Display	Possible Causes	Solutions
Current detection fault	Err18	1: The HALL device is faulty. 2: The drive board is faulty.	1: Replace the faulty HALL device. 2: Replace the faulty drive board.
Motor auto-tuning fault	Err19	1: The motor parameters are not set according to the nameplate. 2: The motor auto-tuning times out.	1: Set the motor parameters according to the nameplate properly. 2: Check the cable connecting the AC drive and the motor.
Encoder fault	Err20	1: The encoder type is incorrect. 2: The cable connection of the encoder is incorrect. 3: The encoder is damaged. 4: The PG card is faulty.	1: Set the encoder type correctly based on the actual situation. 2: Eliminate external faults. 3: Replace the damaged encoder. 4: Replace the faulty PG card.
EEPROM read-write fault	Err21	The EEPROM chip is damaged.	Replace the main control board.
AC drive hardware fault	Err22	1: Overvoltage exists. 2: Overcurrent exists.	1: Handle based on overvoltage. 2: Handle based on overcurrent.
Short circuit to ground	Err23	The motor is short circuited to the ground.	Replace the cable or motor.
Accumulative running time reached	Err26	The accumulative running time reaches the setting value.	Clear the record through the parameter initialization function.
User-defined fault 1	Err27	1: The user-defined fault 1 signal is input via DI. 2: User-defined fault 1 signal is input via virtual I/O.	Reset the operation.
User-defined fault 2	Err28	1: The user-defined fault 2 signal is input via DI. 2: The user-defined fault 2 signal is input via virtual I/O.	Reset the operation.
Accumulative power-on time reached	Err29	The accumulative power-on time reaches the setting value.	Clear the record through the parameter initialization function.
Load becoming 0	Err30	The AC drive running current is lower than F9-64.	Check that the load is disconnected or the setting of F9-64 and F9-65 is correct.
PID feedback lost during running	Err31	The PID feedback is lower than the setting of FA-26.	Check the PID feedback signal or set FA-26 to a proper value.

Fault Name	Display	Possible Causes	Solutions
Pulse-by-pulse current limit fault	Err40	1: The load is too heavy or locked-rotor occurs on the motor. 2: The AC drive model is of too small power class.	1: Reduce the load and check the motor and mechanical condition. 2: Select an AC drive of higher power class.
Motor switchover fault during running	Err41	Change the selection of the motor via terminal during running of the AC drive.	Perform motor switchover after the AC drive stops.
Too large speed deviation	Err42	1: The encoder parameters are set incorrectly. 2: The motor auto-tuning is not performed. 3: F9-69 and F9-70 are set incorrectly.	1: Set the encoder parameters properly. 2: Perform the motor auto-tuning. 3: Set F9-69 and F9-70 correctly based on the actual situation.
Motor over-speed	Err43	1: The encoder parameters are set incorrectly. 2: The motor auto-tuning is not performed. 3: F9-69 and F9-70 are set incorrectly.	1: Set the encoder parameters properly. 2: Perform the motor auto-tuning. 3: Set F9-69 and F9-70 correctly based on the actual situation.
Motor overheat	Err45	1: The cabling of the temperature sensor becomes loose. 2: The motor temperature is too high.	1: Check the temperature sensor cabling and eliminate the cabling fault. 2: Lower the carrier frequency or adopt other heat radiation measures.
Initial position fault	Err51	The motor parameters are not set based on the actual situation.	Check that the motor parameters are set correctly and whether the setting of rated current is too small.

9.4 Common Faults and Solutions

You may come across the following faults during the use of the AC drive. Refer to the following table for simple fault analysis.

Table 9-2 Troubleshooting to common faults of the AC drive

SN	Fault	Possible Causes	Solutions
1	There is no display at power-on.	1: There is no power supply to the AC drive or the power input to the AC drive is too low. 2: The power supply of the switch on the drive board of the AC drive is faulty. 3: The rectifier bridge is damaged. 4: The control board or the operation panel is faulty. 5: The cable connecting the control board and the drive board and the operation panel breaks.	1: Check the power supply. 2: Check the bus voltage. 3: Re-connect the 8-core and 28-core cables. 4: Contact the agent or Inovance for technical support.
2	"HC" is displayed at power-on.	1: The cable between the drive board and the control board is in poor contact. 2: Related components on the control board are damaged. 3: The motor or the motor cable is short circuited to the ground. 4: The HALL device is faulty. 5: The power input to the AC drive is too low.	1: Re-connect the 8-core and 28-core cables. 2: Contact the agent or Inovance for technical support.
3	"Err23" is displayed at power-on.	1: The motor or the motor output cable is short-circuited to the ground. 2: The AC drive is damaged.	1: Measure the insulation of the motor and the output cable with a megger. 2: Contact the agent or Inovance for technical support.
4	The AC drive display is normal upon power-on. But "HC" is displayed after running and stops immediately.	1: The cooling fan is damaged or locked-rotor occurs. 2: The external control terminal cable is short circuited.	1: Replace the damaged fan. 2: Eliminate external fault.
5	Err14 (module overheat) fault is reported frequently.	1: The setting of carrier frequency is too high. 2: The cooling fan is damaged, or the air filter is blocked. 3: Components inside the AC drive are damaged (thermal coupler or others).	1: Reduce the carrier frequency (F0-15). 2: Replace the fan and clean the air filter. 3: Contact the agent or Inovance for technical support.

SN	Fault	Possible Causes	Solutions
6	The motor does not rotate after the AC drive runs.	<ol style="list-style-type: none"> 1: Check the motor and the motor cables. 2: The AC drive parameters are set improperly (motor parameters). 3: The cable between the drive board and the control board is in poor contact. 4: The drive board is faulty. 	<ol style="list-style-type: none"> 1: Ensure the cable between the AC drive and the motor is normal. 2: Replace the motor or clear mechanical faults. 3: Check and re-set motor parameters.
7	The DI terminals are disabled.	<ol style="list-style-type: none"> 1: The parameters are set incorrectly. 2: The external signal is incorrect. 3: The jumper bar across OP and +24 V becomes loose. 4: The control board is faulty. 	<ol style="list-style-type: none"> 1: Check and reset the parameters in group F4. 2: Re-connect the external signal cables. 3: Re-confirm the jumper bar across OP and +24 V. 4: Contact the agent or Inovance for technical support.
8	The motor speed is always low in CLVC mode.	<ol style="list-style-type: none"> 1: The encoder is faulty. 2: The encoder cable is connected incorrectly or in poor contact. 3: The PG card is faulty. 4: The drive board is faulty. 	<ol style="list-style-type: none"> 1: Replace the encoder and ensure the cabling is proper. 2: Replace the PG card. 3: Contact the agent or Inovance for technical support.
9	The AC drive reports overcurrent and overvoltage frequently.	<ol style="list-style-type: none"> 1: The motor parameters are set improperly. 2: The acceleration/deceleration time is improper. 3: The load fluctuates. 	<ol style="list-style-type: none"> 1: Re-set motor parameters or re-perform the motor auto-tuning. 2: Set proper acceleration/ deceleration time. 3: Contact the agent or Inovance for technical support.
10	Err17 is reported upon power-on or running.	The soft startup contactor is not picked up.	<ol style="list-style-type: none"> 1: Check whether the contactor cable is loose. 2: Check whether the contactor is faulty. 3: Check whether 24 V power supply of the contactor is faulty. 4: Contact the agent or Inovance for technical support.
11	##### is displayed upon power-on.	Related component on the control board is damaged.	Replace the control board.



Warranty Agreement

1. The warranty period of the product is 18 months (refer to the barcode on the equipment). During the warranty period, if the product fails or is damaged under the condition of normal use by following the instructions, Inovance will be responsible for free maintenance.
2. Within the warranty period, maintenance will be charged for the damages caused by the following reasons:
 - a. Improper use or repair/modification without prior permission
 - b. Fire, flood, abnormal voltage, other disasters and secondary disaster
 - c. Hardware damage caused by dropping or transportation after procurement
 - d. Improper operation
 - e. Trouble out of the equipment (for example, external device)
3. If there is any failure or damage to the product, please correctly fill out the Product Warranty Card in detail.
4. The maintenance fee is charged according to the latest Maintenance Price List of Inovance.
5. The Product Warranty Card is not re-issued. Please keep the card and present it to the maintenance personnel when asking for maintenance.
6. If there is any problem during the service, contact Inovance's agent or Inovance directly.
7. This agreement shall be interpreted by Shenzhen Inovance Technology Co., Ltd.

Service Department, Shenzhen Inovance Technology Co., Ltd.

Address: Block E, Hongwei Industry Park, Liuxian Road, Baocheng No. 70 Zone, Bao'an District, Shenzhen P.C.: 518101

Website: www.inovance.cn



Product Warranty Card

Customer information	Add. of unit:	
	Name of unit: P.C.:	Contact person:
		Tel.:
Product information	Product model:	
	Body barcode (Attach here):	
	Name of agent:	
Failure information	(Maintenance time and content):	
	Maintenance personnel:	



MD380 Series

High-Performance AC Drive

Shenzhen Inovance Technology Co.,LTD.

Address: Block E, Hongwei Industry Park, Liuxian Road,
Baocheng No. 70 Zone, Bao'an District, Shenzhen
Tel : (0755)2979 9595
Fax : (0755)2961 9897
Technical support : 400-777-1260
<http://www.inovance.cn>