

# KRACHT

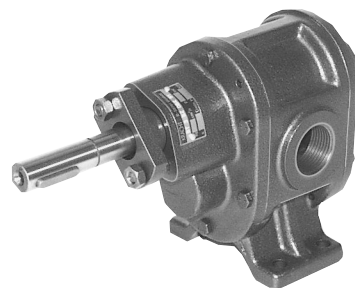

Gear Pumps

**BT, BTH**

## Construction

### Basic construction of BT (rear bearing cover removed)

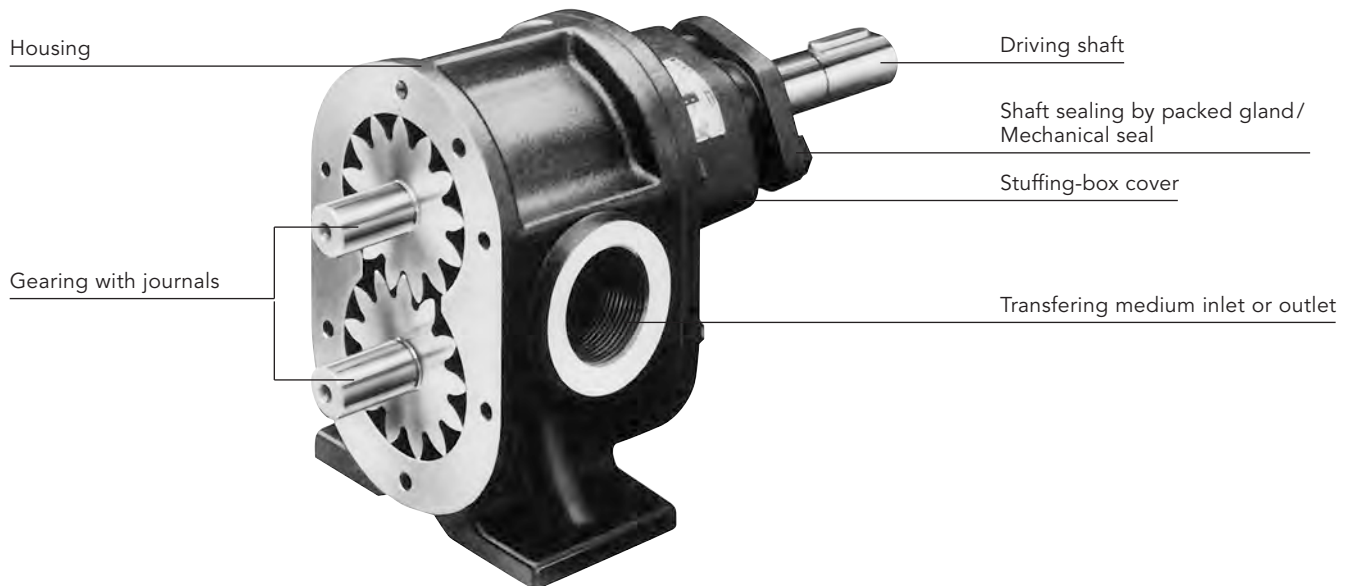

### Basic construction of BTH (rear bearing cover removed)

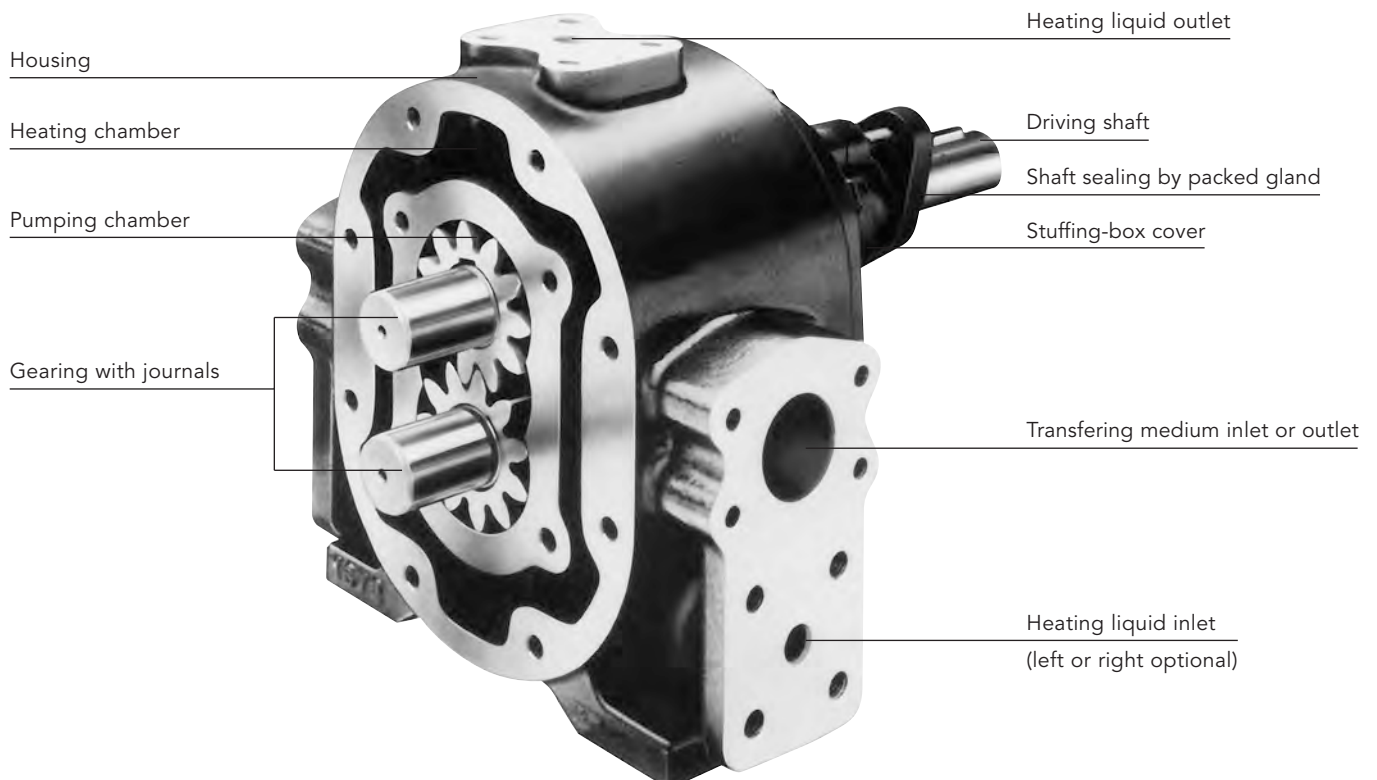

## Function

Pumps series BT and BTH are low speed gear pumps for transferring medium and high viscosity fluids, provided they have certain minimum amount of lubricating property, do not contain any solids and are chemically compatible with the materials of construction.

The standard material of construction for housing, bearing cover and stuffing box cover is grey cast iron. The shafts and gears are manufactured from case hardening steel, hardened and ground.

The shafts are carried in plain bearings manufactured in bronze, with an option of sintered iron.

The rotary shaft seal is a packed gland consisting of PTFE filled aramid yarn, and the static sealing between mating parts is by means of either, liquid sealant or gaskets. All sealing materials are asbestos free.

External axial loads are not permissible, restricted radial loads can be absorbed, dependant on their magnitude and direction.

Driving by flexible shaft coupling is preferred.

In the case of fluids which require elevated temperatures to flow i. e. bitumen, wax etc. the BTH series pump should be used. In this model the housing is double walled to provide a heating jacketed.

The pump transfer chamber is heated by circulating heat transfer fluid or steam through the jacket.

The standard range of models is complimented by a range of a special models described below.

The pump size BT 2 can be supplied in a corrosion and acid - resistant construction (stainless steel body and gear) with carbone plain bearings bushes; the operating pressure of this pump is limited to 5 bars.

BT1 up to BT4 pumps can be manufactured with bronze housing and with further combinations of stainless steel gears and shafts or bronze gears and stainless steel shafts.

**For use on liquids with an abrasive nature and high corrosive effects like resins, certain paints and varnishes as well as glues a special construction, Code No. / 04, is recommended, which is available for pump sizes BT1 up to BT7.**

**In this model all pump parts which are in contact with the transferring fluid are protected from wear and corrosion by a chemically deposited Ni/SiC- dispersion layer. This treatment substantially extends the service life compared with that of a standard model when used in these types of fluid.**

## General Characteristics

Fixing type	Foot mounting
Pipe connection	BT: Whitworth-Pipe thread BTH: Whitworth-Pipe thread flange, flange with counterflange
Direction of rotation	BT = clockwise <b>and</b> anticlockwise BTH = clockwise <b>or</b> anticlockwise
Weight	see page 11 ... 15
Fitting position	horizontal
Ambient temperature	$\vartheta_{u \min} = -10\text{ °C}$ $\vartheta_{u \max} = 60\text{ °C}$

## Operating Characteristics

Operating pressure	
Inlet port	$p_{e \min} = -0.4\text{ bar}$
Outlet port *	$p_N = 8\text{ bar}$ 1 bar to BT0 5 bar to BT2 stainless steel
max. pressure in the heating jacket	$p_H = 10\text{ bar}$
Temperature range	$\vartheta_{m \min} = -10\text{ °C}$ $\vartheta_{m \max} = 220\text{ °C}$
Viscosity range	$\nu_{\min} = 76\text{ mm}^2/\text{s}$ $\nu_{\max} = 30\,000\text{ mm}^2/\text{s}$ Viscosities other than within this range on request
Discharge flow	see table page 9, 10
Power input speeds	$n_{\min} = 100\text{ 1/min}$ $n_{\max} = 750\text{ 1/min}$

## Suitable Fluids

Lubricating-, Cutting oils	Waste oils	Adhesives, Plastics	Cellulose
Soluble-, Steel hardening-,	Bitumen	Binding agents	etc.
Rolling-, Drawing oils	Paints	Resins	
Diesel oils	Greases	Glue, Glue liquors	
Fuel oil S	Synthetic resin varnishes	Molasses	
Engine oils	Nitrocellulose lacquers	Waxes	

## Other Types

Pump with electric motor, coupling and coupling guard mounted on a common base plate.

## Accessories

Flexible coupling

\* higher operating pressure on request

Type Key

BT	0	B	Z	0	A	C	51/	.
BT	2	B	Z	0	R	T	51/	.
BT	1...4	B	Z	0	U	S T	51/	.
BT	1...7	B	Z	0	B C	K	51/	.
BT	1...7	B	Z	0	C	K	51/	04
BTH	1+2	R L	.	0	B C	K	51	.
BTH	3	R L	.	0	B C	F	51	.

Code-No. for special construction  
04 Wear and corrosion protected model

Kind of sealing (Packing)  
51 Arolan

Construction of gear unit

- C Steel shafts and gear unhardened
- K Steel shafts and gear hardened
- F Steel shafts and gear hardened
- S Stainless steel shaft (material No. 1.4057) bronze gear
- T Stainless steel shafts and gear heat treated (material No. 1.4057)

Construction of housing and friction bearing

- A Cast iron without bearing bush
- B Cast iron with Bz bearing bush
- C Iron bearing bush
- U Bronze without bearing bush
- R Stainless steel with carbon-bearing bush (mat. No. 1.4308)

Design code

0 (specified by KRACHT)

Pipe connection

- Z Whitworth pipe thread
- F Flange
- G Flange with counter flange

Direction of rotation

- R Clockwise
- L Anticlockwise
- B Clockwise and anticlockwise

Series

Product code

- BT without heating jacket (Cylindrical shaft end without step bearing, with packing and threaded pipe connection)
- BTH with heating jacket (Cylindrical shaft end without step bearing, with packing, threaded pipe- or flange connection)

## Gear Pumps BT – ATEX

Pumps of the series BT are also available in ATEX design.

The pumps can be used as follows:

- a. In Zone 2 (Gas-⊕, Category 3G) in explosion groups IIA and IIB and IIC
- b. In Zone 1 (Gas-⊕, Category 2G) in explosion groups IIA and IIB and IIC

Qualification with regard to surface temperature is T4. For all gases, vapours, mists with an ignition temperature > 135 °C, the pumps are not an ignition source.

The permissible temperature range extends from -20 °C T<sub>a</sub> 60 °C.

## Identification in accordance with EC Directive RL 94/9/EG

Manufacturer: Kracht GmbH  
58791 Werdohl, Germany

Type designation: BT ...

Job No., Production Date: xxxxxx/xx-xxx xx.xx

Tech. File Ref.: TFR: 07.01X

Ignition protection designation: ⊕ II 2 G ck T4

The ATEX design BT pumps are equipped with a mechanical seal with a fluid receiver. In the area of the fluid receiver the BT-ATEX has a connection for a container for filling the receiver fluid. An overflow serves to monitor the amount which leaks from mechanical seal.

## Construction BT – ATEX

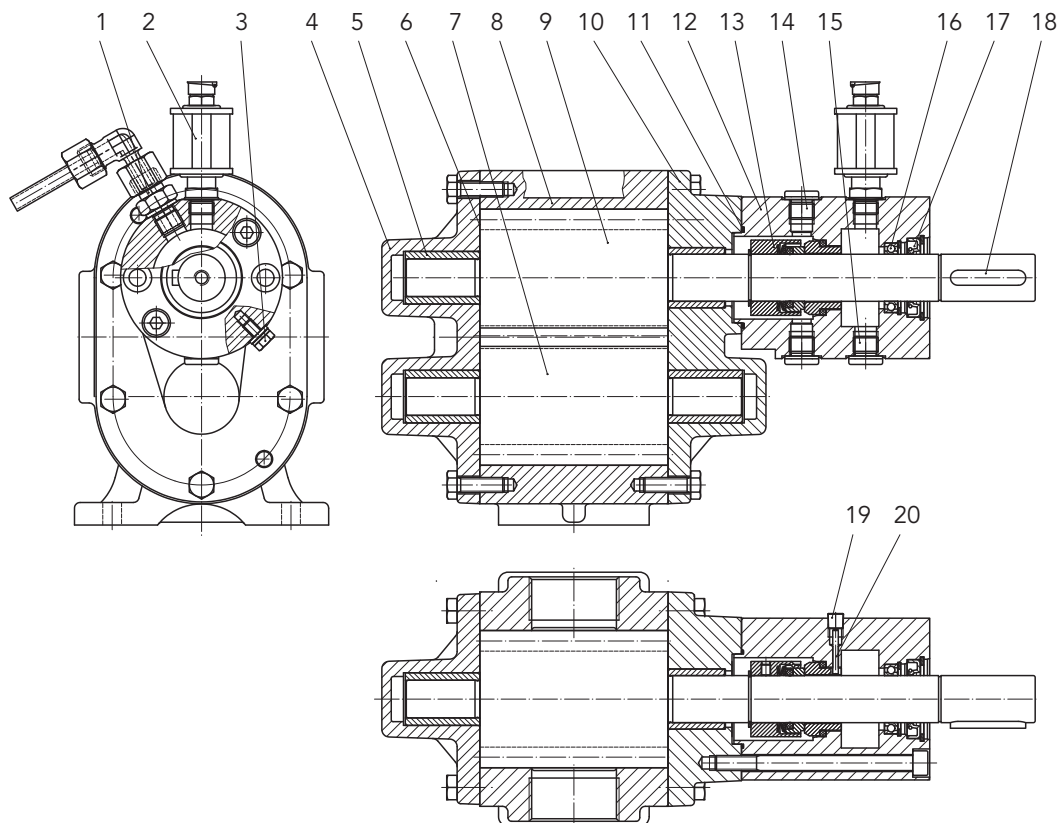

- |                                       |                 |                    |                         |
|---------------------------------------|-----------------|--------------------|-------------------------|
| 1 Overflow                            | 6 Fluid gasket  | 11 O-Ring          | 16 Bearing              |
| 2 Container for the preliminary fluid | 7 Driven shaft  | 12 Seal retainer   | 17 Rotary shaft seal    |
| 3 Earth connection                    | 8 Housing       | 13 Mechanical seal | 18 Parallel key         |
| 4 Front cover                         | 9 Driving shaft | 14 Vent screw      | 19 Screw plug           |
| 5 Plain bearing bush                  | 10 Cover        | 15 Drain plug      | 20 Antitwist protection |

## Gear Pumps BT – ATEX

### General Characteristics

Design	External gear pump
Pipe connection	Whitworth-Pipe thread
Mounting position	Horizontal
Fixing type	Foot mounting
Direction of rotation	clockwise <b>and</b> anticlockwise
Ambient temperature	$\vartheta_{u \min}$ - 10 °C $\vartheta_{u \max}$ 40 °C

Filtering	Filter fineness 60 µm (If required, install a suction filter to prevent the pump from being jammed by foreign particles).
Permissible media	Inflammable and non-inflammable liquids without abrasive ingredients which are compatible with the materials of which the pump is made. The liquid must not be static charged. Flame point and minimum ignition temperature must be observed by the operator. Media-specific characteristics must be taken into consideration. The fluid must have a minimum amount of lubricity.

### Operating Characteristics

Temperature range	$\vartheta_{u \min}$ - 10 °C $\vartheta_{u \max}$ 60 °C
Speed	$n_{\min}$ 100 1/min $n_{\max}$ 750 1/min
Viscosity	$\nu_{\min}$ 76 mm <sup>2</sup> /s $\nu_{\max}$ 20000 mm <sup>2</sup> /s
Operating pressure Inlet port	$p_{e \min}$ - 0.4 bar $p_{e \max}$ 8 bar
Outlet port	$p_{n \max}$ 8 bar
Axial and centrifugal forces on shaft end	Not allowed



**For certain operating conditions, the stated minimum and maximum values are not valid! Thus, for example, the maximum operating pressure is not permissible in conjunction with low rpm and minimum viscosity.**



**Media-specific characteristics must be observed, e.g. in the case of emulsions and solutions containing water, the maximum operating temperature is 50 °C, the pump must be located beneath the level of the liquid.**

### Materials

Housing, bearings, gears	see type key*
Mechanical sealing	SiC-SiC, FFKM, Stainless steel
Other media-side seals	Loctite 510, FEP with FKM-core
Uni-oiler	Ms, Plexiglas
Type plate	Stainless steel
Notched nail	Al (Mg portion < 7.5 %)
Gasket ring screw-plugs	Cu
Other parts	St

\* see type label at pump: BT...

Type Key ATEX

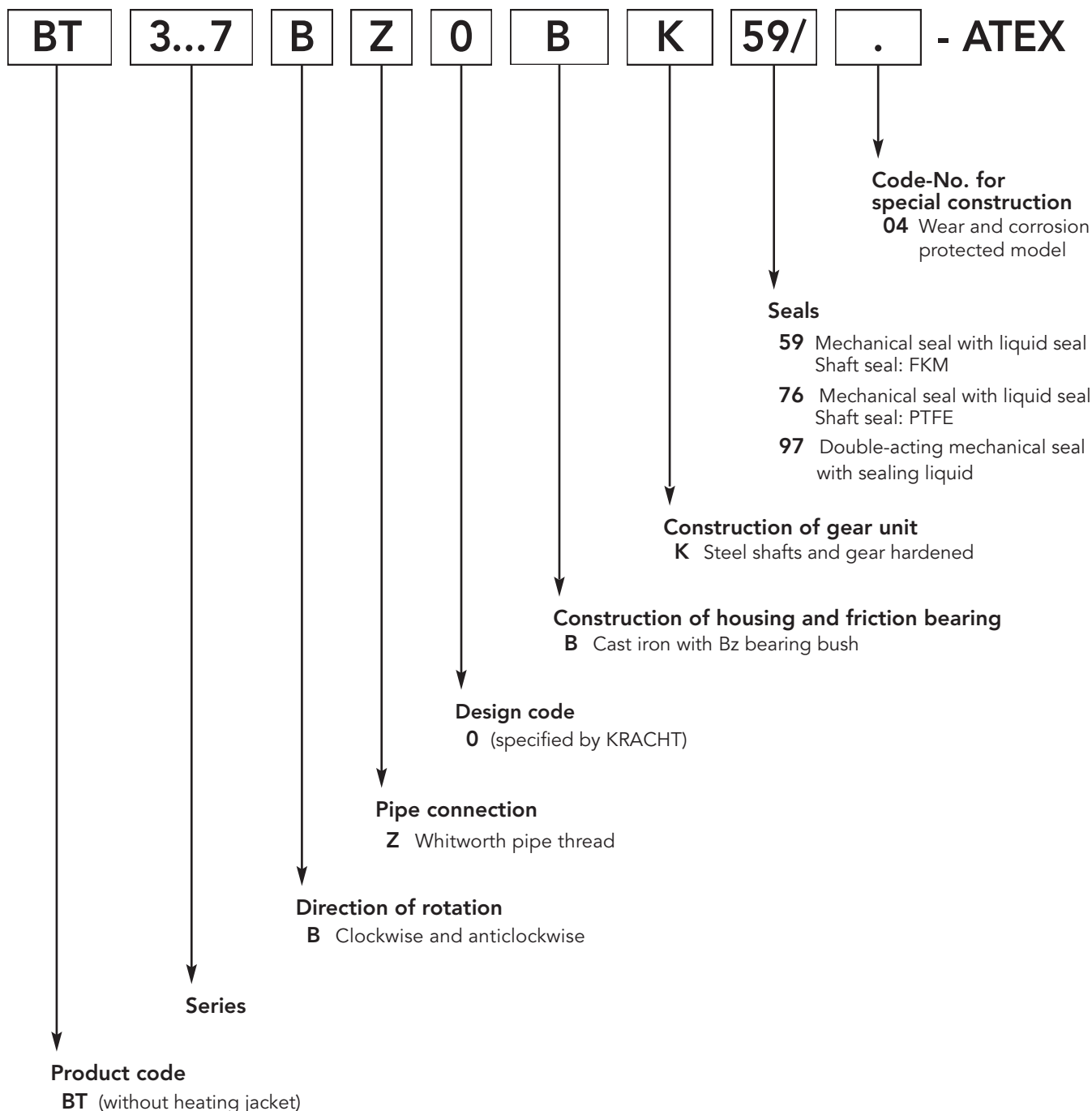



**Power Consumption**

Pump type	V <sub>g</sub> (cm <sup>3</sup> /r)	p (bar)	n = 100 1/min					n = 200 1/min					n = 300 1/min					
			Q (l/min)	Viscosity v (mm <sup>2</sup> /s)				Q (l/min)	Viscosity v (mm <sup>2</sup> /s)				Q (l/min)	Viscosity v (mm <sup>2</sup> /s)				
				76	760	3800	7600		76	760	3800	7600		76	760	3800	7600	
			required power input P (kW)															
BT 0	6.9	1	-	-	-	-	-	1.2	0.07	0.07	0.15	-	1.8	0.07	0.07	0.15	-	
BT 1	32	2	2.5	0.07	0.07	0.07	0.07	5	0.07	0.07	0.15	0.15	7.5	0.07	0.15	0.22	0.22	
		4		0.07	0.07	0.07	0.07		0.07	0.07	0.15	0.22		0.07	0.15	0.22	0.3	
		6		0.07	0.07	0.07	0.07		0.07	0.15	0.15	0.22		0.15	0.15	0.3	0.3	
		8		0.07	0.07	0.07	0.15		0.07	0.15	0.22	0.22		0.15	0.22	0.3	0.3	
BT 2	43	2	4	0.07	0.07	0.15	0.15	8	0.07	0.15	0.22	0.3	12	0.07	0.22	0.37	0.44	
		4		0.07	0.07	0.15	0.15		0.07	0.15	0.3	0.37		0.15	0.3	0.44	0.52	
		6		0.07	0.07	0.15	0.15		0.15	0.22	0.3	0.37		0.22	0.3	0.44	0.52	
		8		0.07	0.15	0.15	0.22		0.15	0.22	0.37	0.37		0.22	0.37	0.52	0.6	
BT 3	91	2	8	0.07	0.15	0.22	0.22	16	0.15	0.22	0.44	0.52	24	0.15	0.37	0.6	0.74	
		4		0.07	0.15	0.22	0.3		0.15	0.3	0.44	0.6		0.3	0.44	0.74	0.88	
		6		0.15	0.15	0.3	0.3		0.22	0.37	0.52	0.6		0.37	0.52	0.81	0.96	
		8		0.15	0.22	0.3	0.37		0.3	0.37	0.6	0.66		0.44	0.6	0.88	1.03	
BT 4	197	2	16	0.15	0.22	0.37	0.52	32	0.22	0.44	0.81	1.03	48	0.3	0.66	1.18	1.47	
		4		0.15	0.3	0.44	0.6		0.37	0.6	0.86	1.18		0.52	0.88	1.4	1.7	
		6		0.22	0.37	0.52	0.6		0.44	0.66	1.03	1.25		0.66	1.03	1.55	1.84	
		8		0.3	0.37	0.6	0.66		0.6	0.74	1.1	1.33		0.81	1.18	1.7	2.0	
BT 5	254	2	24	0.22	0.37	0.66	0.74	48	0.44	0.74	1.25	1.55	72	0.52	1.03	1.9	2.4	
		4		0.3	0.44	0.74	0.88		0.6	0.88	1.47	1.77		0.81	1.4	2.3	2.7	
		6		0.37	0.52	0.81	0.96		0.74	1.1	1.7	2.0		1.03	1.7	2.5	2.9	
		8		0.44	0.6	0.88	1.03		0.88	1.25	1.84	2.13		1.25	1.9	2.7	3.3	
BT 6	352	2	34	0.3	0.52	0.88	1.1	68	0.6	0.96	1.77	2.2	102	0.66	1.47	2.7	3.3	
		4		0.44	0.66	1.03	1.25		0.88	1.25	2.06	2.5		1.1	1.9	3.1	3.8	
		6		0.6	0.74	1.18	1.4		1.1	1.47	2.28	2.7		1.47	2.2	3.5	4.1	
		8		0.66	0.88	1.25	1.47		1.33	1.7	2.5	2.95		1.77	2.6	3.8	4.4	
BT 7	494	2	48	0.37	0.66	1.25	1.55	96	0.74	1.33	2.4	3.0	144	0.96	2.06	3.7	4.7	
		4		0.52	0.88	1.47	1.77		1.1	1.77	2.9	3.5		1.55	2.65	4.4	5.2	
		6		0.66	1.03	1.62	1.9		1.47	2.06	3.2	3.8		2.06	3.2	4.8	5.7	
		8		0.88	1.18	1.77	2.06		1.77	2.36	3.5	5.0		2.43	3.6	5.2	6.1	
BTH 1/55	97	2	9.5	0.07	0.15	0.3	0.3	19	0.15	0.3	0.52	0.66	28.5	0.22	0.44	0.81	0.96	
		4		0.15	0.22	0.3	0.37		0.22	0.37	0.6	0.74		0.37	0.6	0.88	1.1	
		6		0.15	0.22	0.3	0.37		0.3	0.44	0.66	0.77		0.44	0.66	0.96	1.18	
		8		0.22	0.22	0.37	0.44		0.44	0.52	0.74	0.81		0.52	0.74	1.1	1.25	
BTH 1/105	186	2	17	0.15	0.3	0.52	0.6	34	0.3	0.52	0.96	1.18	51	0.37	0.81	1.4	1.8	
		4		0.22	0.37	0.6	0.66		0.44	0.66	1.1	1.33		0.6	1.03	1.6	2.0	
		6		0.3	0.4	0.62	0.74		0.6	0.81	1.25	1.47		0.81	1.18	1.8	2.2	
		8		0.37	0.44	0.66	0.81		0.74	0.88	1.33	1.55		0.96	1.4	2.0	2.4	
BTH 2/100	393	2	38	0.3	0.52	0.96	1.18	76	0.6	1.03	1.84	2.3	114	0.74	1.6	2.7	3.6	
		4		0.44	0.66	1.1	1.33		0.88	1.33	2.14	2.6		1.18	2.0	3.2	4.0	
		6		0.6	0.81	1.25	1.47		1.1	1.62	2.43	2.9		1.55	2.4	3.6	4.3	
		8		0.66	0.88	1.33	1.55		1.33	1.84	2.65	3.1		1.9	2.7	3.9	4.7	
BTH 2/130	510	2	50	0.37	0.66	1.25	1.55	100	0.74	1.3	2.4	3.0	150	1.0	2.1	3.7	4.7	
		4		0.52	0.88	1.47	1.77		1.1	1.8	2.9	3.5		1.6	2.7	4.3	5.3	
		6		0.66	1.03	1.62	1.9		1.5	2.1	3.2	3.8		2.1	3.2	4.8	5.8	
		8		0.88	1.18	1.77	2.1		1.8	2.4	3.5	4.0		2.4	3.6	5.3	6.2	
BTH 3/150	1056	2	100	0.88	1.47	2.6	3.2	200	1.5	2.9	5.1	6.3	300	2.2	4.4	7.7	9.4	
		4		1.18	1.84	3.0	3.6		2.4	3.7	6.0	7.1		3.3	5.5	8.8	10.7	
		6		1.47	2.14	3.3	3.8		3.0	4.3	6.5	7.7		4.2	6.4	9.7	11.6	
		8		1.84	2.43	3.6	4.2		3.7	4.9	7.1	8.3		5.1	7.3	10.6	12.4	

**Power input required at high viscosities**

Viscosities above values specified in the table require a higher power input. In such cases the power input of the pump P<sub>1Pu</sub> can be determined by means of the viscosity factor f<sub>v</sub> (see table page 10) as follows:

$$P_{1Pu} = P_{Tab\ 76} + f_v \cdot Q_{Tab}$$

Example:

BT 4 n = 200 1/min; v = 10 000 mm<sup>2</sup>/s; p = 8 bar with P<sub>tab 76</sub> = 0.6 kW, table data at v = 76 mm<sup>2</sup>/s  
 f<sub>v</sub> = 27 x 10<sup>-3</sup> kW min/l  
 Q<sub>Tab</sub> = 32 l/min  
 gives power input P<sub>1Pu</sub> = 1.46 kW

**Power Consumption**

Pump type	Vg (cm <sup>3</sup> /r)	p (bar)	n = 400 1/min				n = 500 1/min				n = 600 1/min				n = 700 1/min			
			Q (l/min)	Viscosity v (mm <sup>2</sup> /s)			Q (l/min)	Viscosity v (mm <sup>2</sup> /s)			Q (l/min)	Viscosity v (mm <sup>2</sup> /s)			Q (l/min)	Viscosity v (mm <sup>2</sup> /s)		
				76	760	3800		76	760	3800		76	760	3000		76	760	2000
			req. power input P (kW)				req. power input P (kW)				req. power input P (kW)				req. power input P (kW)			
BT 0	6.9	1	2.5	0.07	0.15	—	3.1	0.15	0.15	—	3.8	0.15	0.15	—	4.4	0.15	0.15	—
BT 1	32	2	10	0.07	0.15	0.3	12.5	0.07	0.2	0.35	15	0.08	0.2	0.34	17.5	0.09	0.23	0.32
		4		0.15	0.22	0.37		0.15	0.25	0.4		0.18	0.3	0.44		0.21	0.35	0.44
		6		0.15	0.22	0.37		0.2	0.3	0.45		0.24	0.36	0.5		0.28	0.42	0.51
		8		0.22	0.3	0.44		0.22	0.35	0.5		0.26	0.38	0.52		0.3	0.44	0.53
BT 2	43	2	16	0.15	0.3	0.6	20	0.15	0.37	0.66	24	0.18	0.37	0.48	28	0.21	0.43	0.57
		4		0.22	0.37	0.66		0.27	0.44	0.74		0.32	0.51	0.62		0.37	0.59	0.73
		6		0.3	0.37	0.74		0.34	0.52	0.81		0.4	0.59	0.8		0.47	0.69	0.83
		8		0.3	0.44	0.96		0.37	0.52	1.03		0.45	0.64	0.85		0.53	0.75	0.89
BT 3	91	2	32	0.22	0.44	1.03	40	0.3	0.6	1.1	48	0.36	0.74	1.18	56	0.42	0.87	1.15
		4		0.37	0.6	1.1		0.44	0.74	1.18		0.53	0.91	1.35		0.62	1.07	1.35
		6		0.44	0.66	1.25		0.6	0.88	1.33		0.72	1.1	1.54		0.84	1.29	1.57
		8		0.52	0.74	1.33		0.66	0.96	1.4		0.8	1.18	1.62		0.93	1.38	1.66
BT 4	197	2	64	0.44	0.88	2.0	80	0.52	1.1	2.06	96	0.63	1.11	2.26	112	0.74	1.64	2.2
		4		0.66	1.18	2.2		0.88	1.47	2.36		1.05	1.53	2.68		1.23	2.13	2.69
		6		0.88	1.33	2.43		1.1	1.7	2.58		1.32	1.8	2.95		1.54	2.44	3.0
		8		1.03	1.55	2.58		1.33	1.9	2.8		1.6	2.08	3.23		1.87	2.77	3.33
BT 5	254	2	96	0.66	1.4	3.2	120	0.81	1.8	3.3	144	1.0	2.2	3.4	168	1.2	2.5	3.4
		4		1.03	1.8	3.5		1.33	2.3	3.8		1.6	2.8	4.0		1.9	3.2	4.1
		6		1.4	2.2	3.9		1.77	2.7	4.2		2.1	3.3	4.5		2.5	3.8	4.7
		8		1.7	2.5	4.2		2.14	3.1	4.6		2.6	3.8	5.0		3.0	4.3	5.2
BT 6	352	2	136	0.88	1.9	4.4	170	1.1	2.4	4.6	204	1.3	2.9	4.8	238	1.5	3.5	4.6
		4		1.47	2.5	5.0		1.9	3.2	5.2		2.3	3.9	5.8		2.7	4.6	5.8
		6		1.9	3.0	5.4		2.4	3.8	5.8		2.9	4.5	6.4		3.4	5.3	6.5
		8		2.4	3.4	6.0		3.0	4.3	6.2		3.6	5.2	7.1		4.2	6.1	7.3
BT 7	494	2	192	1.3	2.7	6.1	240	1.6	3.4	6.2	288	1.9	4.2	6.8	336	2.2	4.9	6.6
		4		2.0	3.6	6.9		2.6	4.4	7.2		3.1	5.4	8.0		3.6	6.3	8.0
		6		2.7	4.2	7.6		3.4	5.2	8.0		4.1	6.4	9.0		4.7	7.4	9.1
		8		3.3	4.7	8.1		4.0	6.0	8.7		4.8	7.1	9.7		5.6	8.3	10.0
BTH 1/55	97	2	38	0.3	0.6	1.25	47.5	0.37	0.74	1.3	57	0.44	0.9	1.4	66.5	0.52	1.05	1.4
		4		0.44	0.74	1.4		0.6	0.96	1.5		0.72	1.18	1.7		0.84	1.37	1.7
		6		0.6	0.88	1.55		0.74	1.1	1.7		0.89	1.35	1.9		1.04	1.57	1.9
		8		0.66	0.96	1.7		0.88	1.25	1.8		1.06	1.52	2.0		1.23	1.76	2.1
BTH 1/105	186	2	68	0.52	1.1	2.4	85	0.66	1.3	2.4	102	0.79	1.6	2.5	119	0.92	1.9	2.5
		4		0.81	1.4	2.6		1.03	1.7	2.8		1.24	2.1	3.0		1.45	2.4	3.0
		6		1.03	1.6	2.9		1.33	2.0	3.1		1.59	2.4	3.3		1.86	2.8	3.4
		8		1.25	1.8	3.1		1.6	2.3	3.4		1.92	2.7	3.7		2.23	3.2	3.8
BTH 2/100	393	2	152	0.96	2.1	4.7	190	1.2	2.6	4.7	228	1.4	3.2	5.3	266	1.7	3.8	5.2
		4		1.55	2.7	5.3		1.9	3.3	5.5		2.3	4.1	6.2		2.6	4.7	6.1
		6		2.1	3.2	5.8		2.6	4.0	6.1		3.1	4.9	7.0		3.6	5.7	7.1
		8		2.5	3.7	6.2		3.2	4.6	6.6		3.8	5.6	7.7		4.5	6.6	8.0
BTH 2/130	510	2	200	1.3	2.8	6.1	250	1.6	3.4	6.2	300	1.9	4.3	7.0	350	2.2	5.0	6.8
		4		2.1	3.6	6.9		2.6	4.4	7.2		3.1	5.5	8.2		3.6	6.4	8.2
		6		2.7	4.2	7.6		3.4	5.3	8.0		4.1	6.5	9.2		4.8	7.6	9.4
		8		3.3	4.7	8.1		4.1	6.0	8.7		4.9	7.3	10.0		5.8	8.6	10.4
BTH 3/150	1056	2	400	2.8	5.8	10.2	500	3.5	7.2	12.7	600	4.2	9.0	14.4	700	4.9	10.5	14.0
		4		4.4	7.4	11.8		5.5	9.2	14.7		6.6	11.4	16.8		7.7	13.3	16.8
		6		5.6	8.6	13.0		7.0	10.7	16.2		8.5	13.3	18.7		9.9	15.5	19.0
		8		6.8	9.7	14.1		7.7	12.2	17.7		9.2	14.0	19.4		10.7	16.3	19.8

kin. viscosity v < mm <sup>2</sup> /s	1000	2000	3000	6000	10000	20000	30000
Max. speed n <sub>max</sub> 1/min	750	600	500	400	300	200	100
Viscosity factor f <sub>v</sub> 10 <sup>-3</sup> kW min/l	9.5	14	17	22.5	27	34	38

Spread of output: ± 5 % of table values Q. Viscosities below 76 mm<sup>2</sup>/s effect a decrease of output flow values, Q.  
The power output of driving motor must exceed the table values P by about 20 %.

Important: When determining the power input required always consider the max. operating viscosity. (e.g. in the starting situation)!



Dimensions

**BTH1 / <sup>55</sup>/<sub>155</sub> • Z0 • K51**

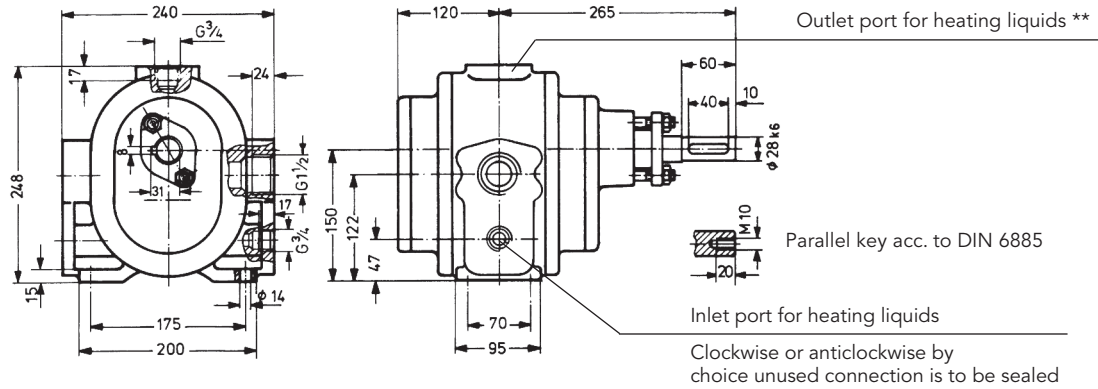

**BTH1 / <sup>55</sup>/<sub>105</sub> • F0 • K51**

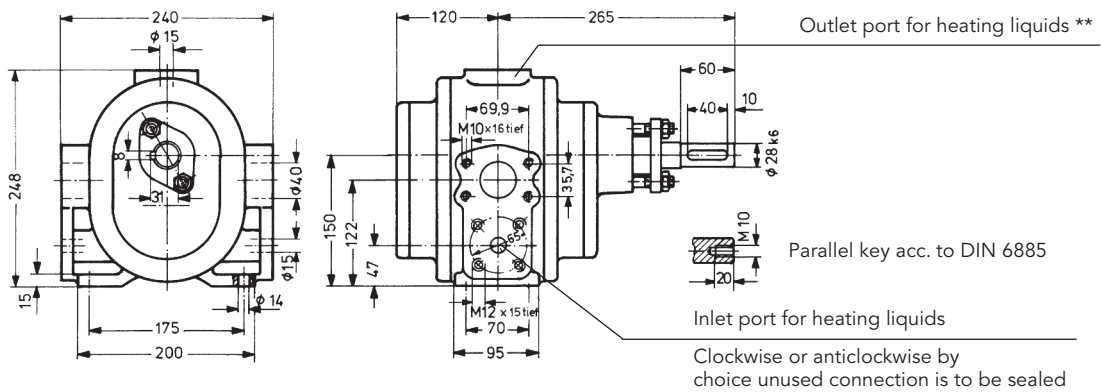

**BTH1 / <sup>55</sup>/<sub>105</sub> • G0 • K51**

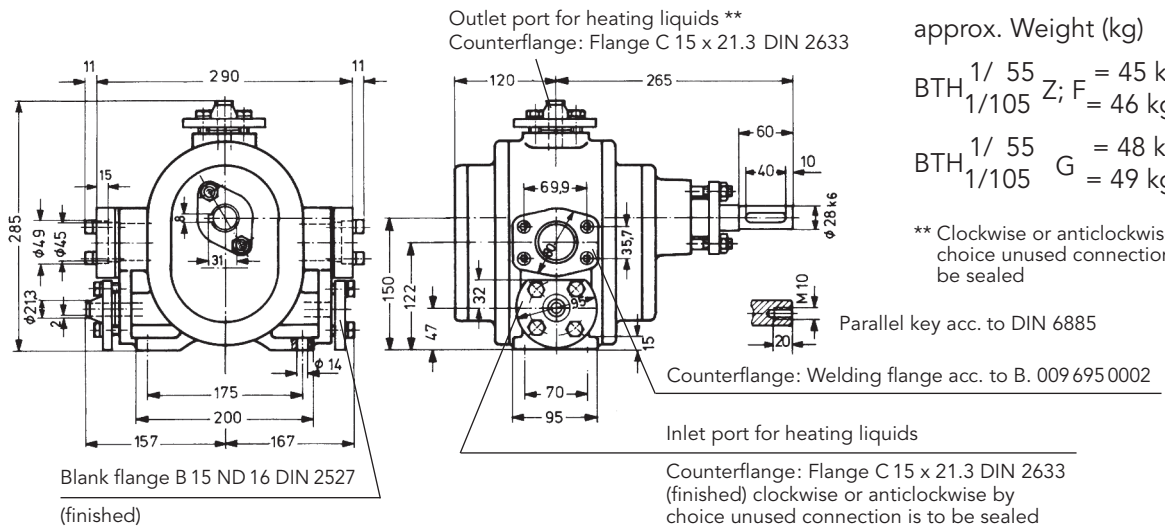

approx. Weight (kg)  
 BTH <sup>1/55</sup>/<sub>105</sub> Z; F = 45 kg  
 BTH <sup>1/55</sup>/<sub>105</sub> G = 46 kg  
 BTH <sup>1/55</sup>/<sub>105</sub> Z; F = 48 kg  
 BTH <sup>1/55</sup>/<sub>105</sub> G = 49 kg

\*\* Clockwise or anticlockwise by choice unused connection is to be sealed

Dimensions

**BTH 2 /  $\frac{100}{130}$  • Z 0 • K 51**

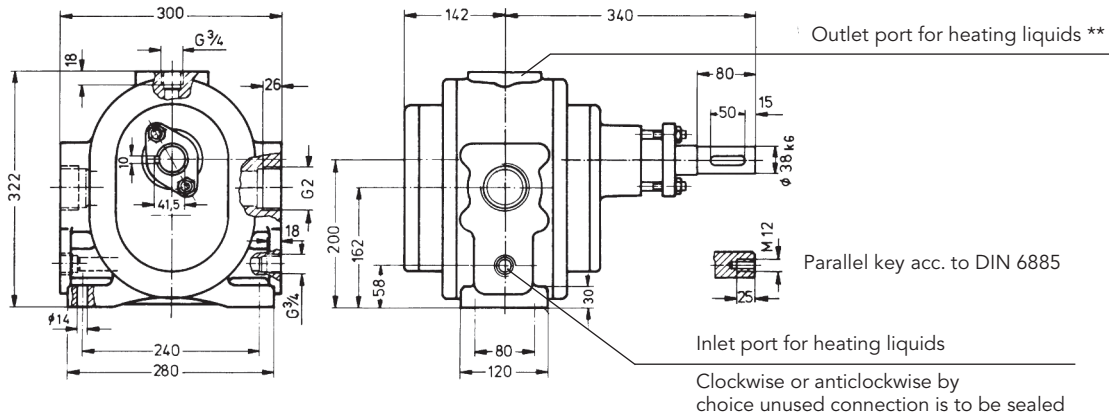

**BTH 2 /  $\frac{100}{130}$  • F 0 • K 51**

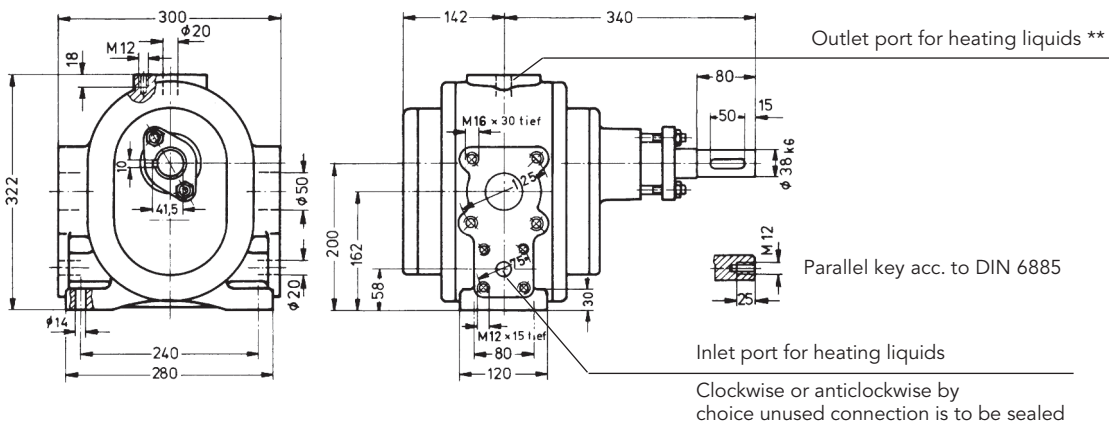

**BTH 2 /  $\frac{100}{130}$  • G 0 • K 51**

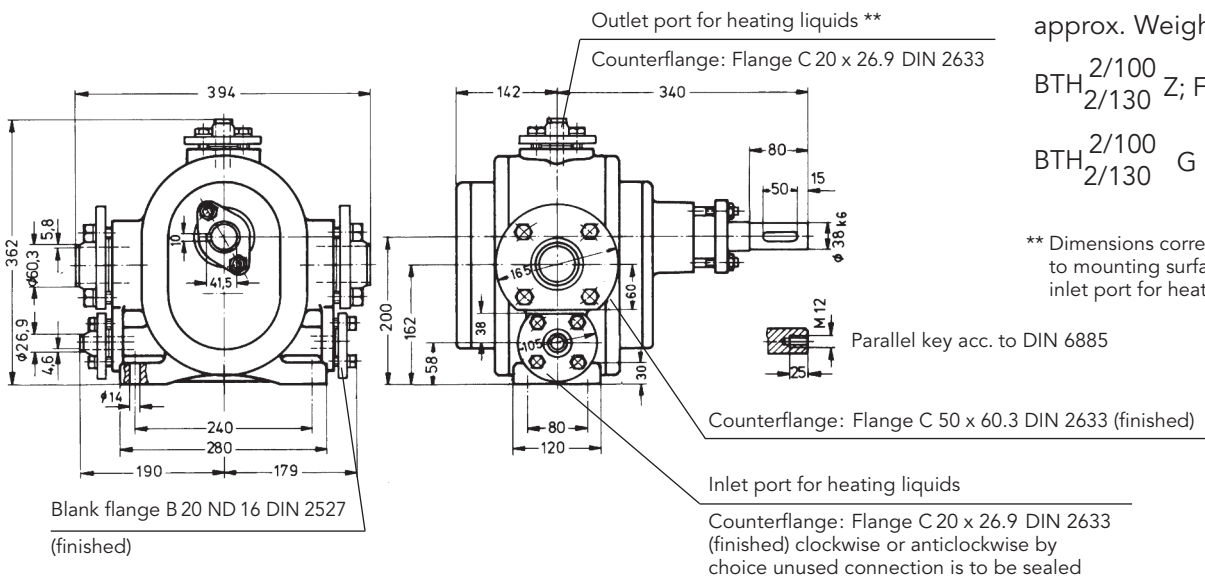

approx. Weight (kg)  
 BTH  $\frac{2}{100}$  Z; F = 84 kg  
 BTH  $\frac{2}{130}$  Z; F = 85 kg  
 BTH  $\frac{2}{100}$  G = 93 kg  
 BTH  $\frac{2}{130}$  G = 94 kg

\*\* Dimensions correspond to mounting surface of inlet port for heating liquids

Dimensions

**BTH3 / 150 • Z0 • F 51**

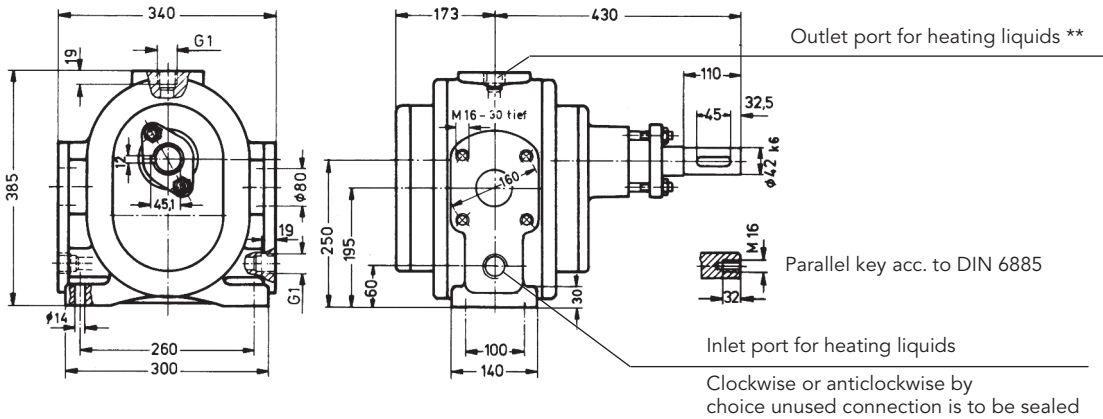

**BTH3 / 150 • F0 • F 51**

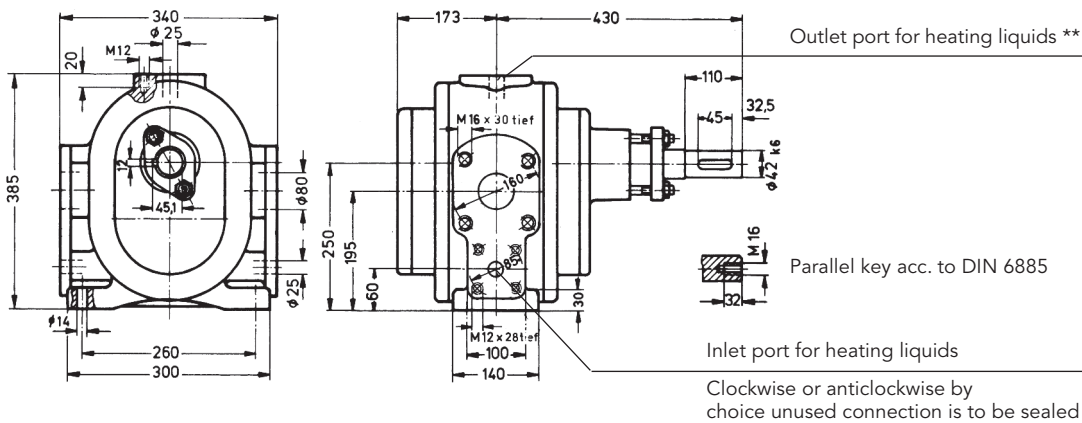

**BTH3 / 150 • G0 • F 51**

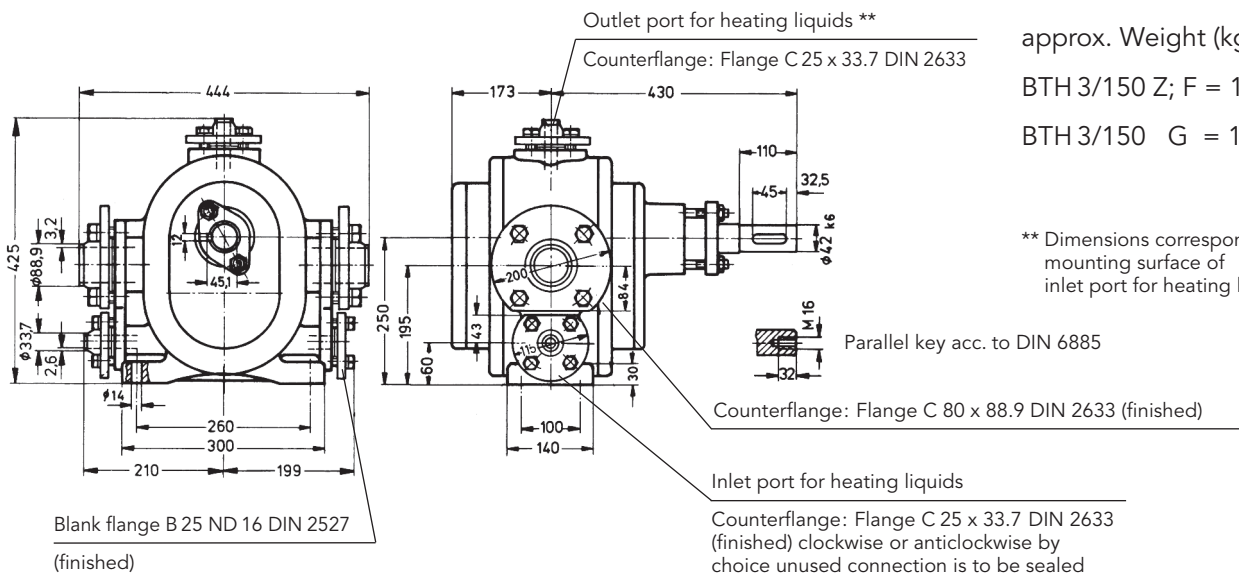

approx. Weight (kg)  
 BTH3/150 Z; F = 142 kg  
 BTH3/150 G = 155 kg

\*\* Dimensions correspond to mounting surface of inlet port for heating liquids

## Dimensions

### BT1...7 BZ 0CK 59

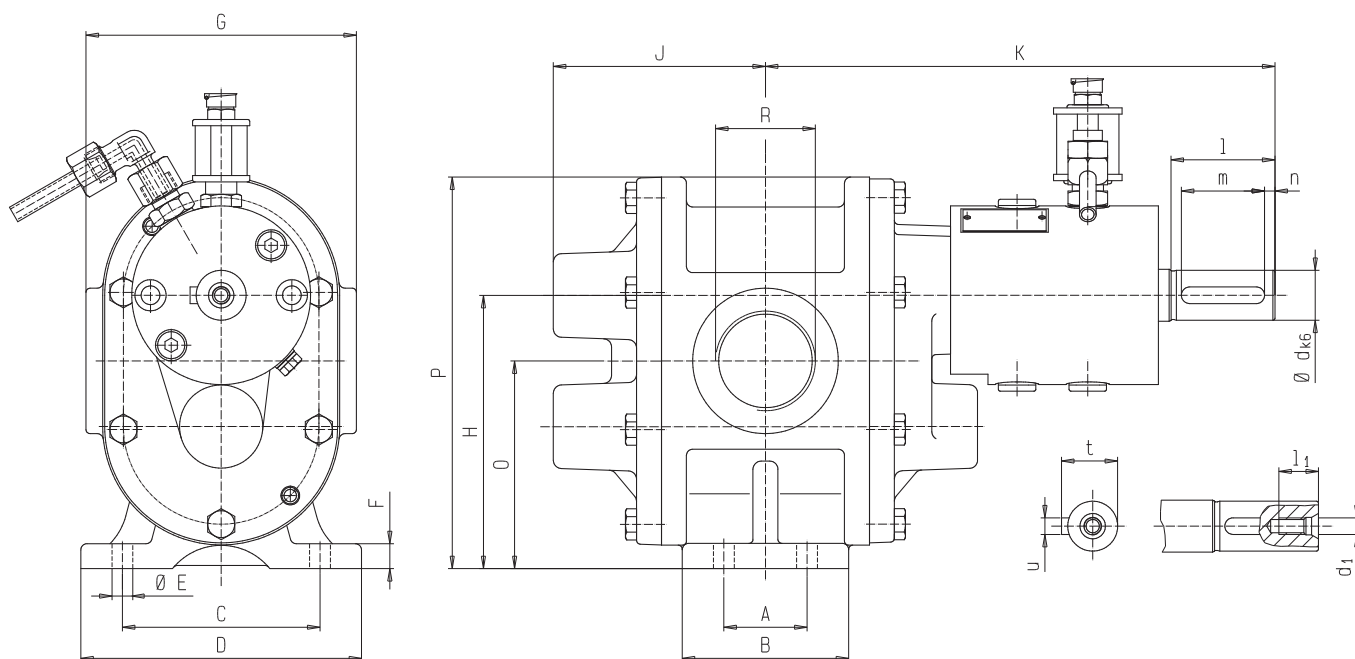

Pump type	R	A	B	C	D	ØE	F	G	H	O	J	K	P	Shaft end							kg	
														Ød	l	m	n	u	t	d <sub>1</sub>		l <sub>1</sub>
<b>BT 4</b>	G2	40	80	95	135	10	12	130	131.5	100	102	245	189	24	50	40	5	8	27	M8	19	18.5
<b>BT 6</b>	G2	35	75	185	225	14	28	175	175	126	106	245	252	24	50	40	5	8	27	M8	19	33.0

Inlet and outlet ports equally sized.

# Product Portfolio

## Gear Pumps

Gear pumps for lubricating oil supply equipment, low pressure filling and feed systems, dosing and mixing systems.

## Hydraulics

Single and multistage high pressure gear pumps and hydraulic motors for construction machinery, vehicle-mounted machines.

## Flow Measurement

Gear, turbine and screw type flow meters and electronics for volume and flow metering technology in hydraulics, processing and laquering technology.

## Valves

Cetop directional control and proportional valves, pressure, quantity and stop valves for pipe and slab construction.

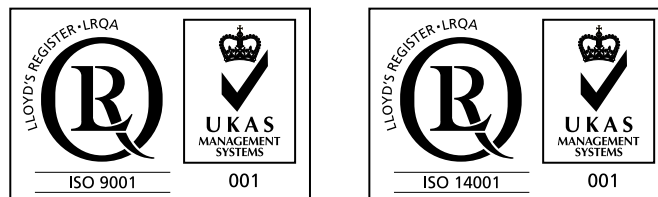

BT, BTH/GB/08.19

# KRACHT

KRACHT GmbH · Gewerbestraße 20 · 58791 Werdohl, Germany · Phone +49 23 92.935-0 · Fax +49 23 92.935 209

Email [info@kracht.eu](mailto:info@kracht.eu) · Web [www.kracht.eu](http://www.kracht.eu)