

SV2 SERIES (~ 2900 rpm)

MAIN CHARACTERISTICS

Working delivery 1.2 to 4.2 m³/h.

Maximum operating pressure, including water hammer on suction side:

- Pumps with oval flanges 16 bar.
- Pumps with round flanges 25 bar.

AVAILABLE VERSIONS

- "F" : In-line ports, round flanges from SV202 to SV224.
- "T" : In-line ports, oval flanges from SV202 to SV214.
- "R" : Overlaying ports, round flanges from SV204 to SV224.
- "N" : In-line ports, round flanges made of AISI 316 from SV202 to SV224.

TABLE OF MATERIALS

| PART | "F" "R" "T" MATERIALS | "N" MATERIALS |
|---------------------------|------------------------------|---------------|
| Impeller | AISI 316 L | |
| Diffuser and upper spacer | AISI 304 | AISI 316 L |
| Shaft | AISI 304 | AISI 316 |
| Outer sleeve | AISI 304 | AISI 316 L |
| Pump body | AISI 304 | AISI 316 L |
| Shaft sleeve | TUNGSTEN CARBIDE | |
| Bushing | CERAMIC | |
| Mechanical seal | TUNGSTEN CARBIDE/CARBON/EPDM | |
| Elastomers | EPDM | |
| Fill/drain plugs | AISI 316 | |
| Adapter | 250 CAST IRON | |
| Coupling | ALUMINIUM | |
| Coupling protection | AISI 304 | |
| Seal holding protection | AISI 304 | AISI 316 L |
| Base mount | ALUMINIUM | |

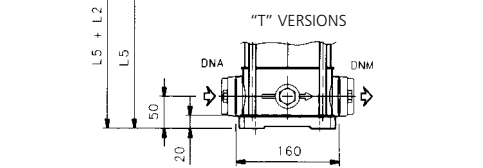
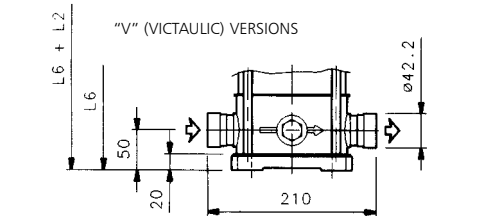
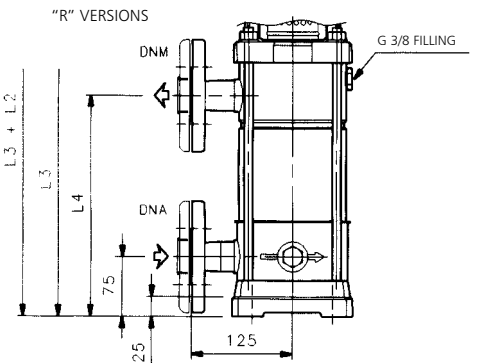
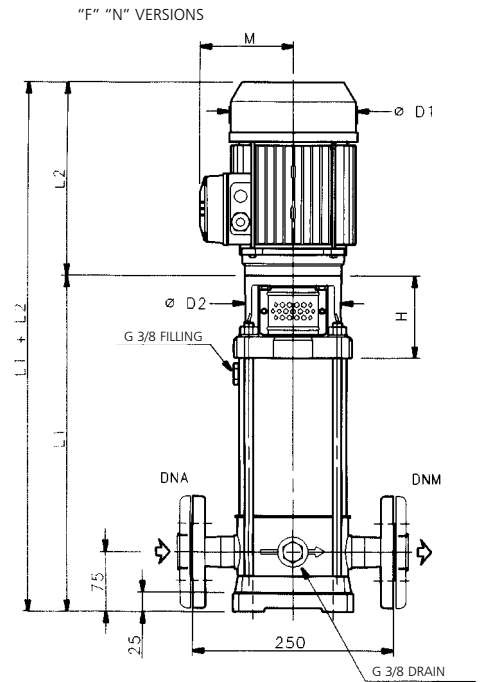

ELECTRICAL SPECIFICATIONS

| PUMP TYPE | MOTOR POWER | | INPUT CURRENT In Amp. | | | | | CAPACITOR | | Is/In | |
|-----------|-------------|------|-----------------------|----------|----------|--------------|-----------|-----------|-------------------------|--------------------|----------|
| | | | THREE-PHASE | | | SINGLE-PHASE | μF | V | THREE-PHASE 230 V 400 V | SINGLE-PHASE 230 V | |
| | | | Δ | Y | Δ | | | | | | 220-240V |
| kW | T | M | 220-240V | 380-415V | 380-415V | 220-240V | | | | | |
| SV202F03T | 0,37 | 71R | 71R | 2,30 | 1,33 | - | 2,64-2,72 | 14 | 450 | 4,23 | 3,08 |
| SV203F03T | 0,37 | 71R | 71R | 2,30 | 1,33 | - | 2,64-2,72 | 14 | 450 | 4,23 | 3,08 |
| SV204F05T | 0,55 | 71 | 71 | 2,48 | 1,43 | - | 3,89-4,05 | 16 | 450 | 5,95 | 3,34 |
| SV205F07T | 0,75 | 80R | 80R | 3,50 | 2,02 | - | 5,22-4,97 | 20 | 450 | 5,81 | 3,55 |
| SV206F07T | 0,75 | 80R | 80R | 3,50 | 2,02 | - | 5,22-4,97 | 20 | 450 | 5,81 | 3,55 |
| SV207F11T | 1,1 | 80 | 80 | 4,52 | 2,61 | - | 7,07-6,81 | 30 | 450 | 6,78 | 3,80 |
| SV208F11T | 1,1 | 80 | 80 | 4,52 | 2,61 | - | 7,07-6,81 | 30 | 450 | 6,78 | 3,80 |
| SV209F11T | 1,1 | 80 | 80 | 4,52 | 2,61 | - | 7,07-6,81 | 30 | 450 | 6,78 | 3,80 |
| SV211F15T | 1,5 | 90R | 90R | 5,98 | 3,45 | - | 9,32-8,63 | 40 | 450 | 7,04 | 3,45 |
| SV212F15T | 1,5 | 90R | 90R | 5,98 | 3,45 | - | 9,32-8,63 | 40 | 450 | 7,04 | 3,45 |
| SV214F22T | 2,2 | 90R | 90 | 8,71 | 5,03 | - | 13,3-12,6 | 50 | 450 | 7,32 | 3,45 |
| SV216F22T | 2,2 | 90R | 90 | 8,71 | 5,03 | - | 13,3-12,6 | 50 | 450 | 7,32 | 3,45 |
| SV218F22T | 2,2 | 90R | 90 | 8,71 | 5,03 | - | 13,3-12,6 | 50 | 450 | 7,32 | 3,45 |
| SV220F30T | 3 | 100R | - | 10,8 | 6,22 | - | - | - | - | 6,81 | - |
| SV222F30T | 3 | 100R | - | 10,8 | 6,22 | - | - | - | - | 6,81 | - |
| SV224F30T | 3 | 100R | - | 10,8 | 6,22 | - | - | - | - | 6,81 | - |

* R = Reduced size of motor casing as compared to shaft extension and flange.

DIMENSIONS AND WEIGHTS

| PUMP TYPE | DNA DNM | DIMENSIONS IN mm | | | | | | | | | | | | | WEIGHT (kg) | | | | |
|-----------|---------|------------------|-----------------------|-----|-----|-----|-----|-----|----------------------|-----------------------|-----|-----|-----|-----|-------------|---------------|----|------|------|
| | | L1 | L2 SINGLE-THREE-PHASE | L3 | L4 | L5 | L6 | L7 | M SINGLE-THREE-PHASE | D1 SINGLE-THREE-PHASE | D2 | H | A | B | PUMP | ELECTRIC PUMP | | | |
| SV202F03T | Rp 1" | 285 | 209 | 209 | - | - | 260 | 260 | 260 | 111 | 111 | 120 | 120 | 105 | 93 | 50 | 20 | 9,5 | 17,5 |
| SV203F03T | Rp 1" | 310 | 209 | 209 | - | - | 285 | 285 | 285 | 111 | 111 | 120 | 120 | 105 | 93 | 50 | 20 | 10 | 18 |
| SV204F05T | Rp 1" | 335 | 231 | 231 | 335 | 200 | 310 | 310 | 310 | 121 | 121 | 140 | 140 | 105 | 93 | 50 | 20 | 10,5 | 19 |
| SV205F07T | Rp 1" | 370 | 226 | 226 | 370 | 225 | 345 | 345 | 345 | 121 | 121 | 140 | 140 | 120 | 103 | 50 | 20 | 11,5 | 21 |
| SV206F07T | Rp 1" | 395 | 226 | 226 | 395 | 250 | 370 | 370 | 370 | 121 | 121 | 140 | 140 | 120 | 103 | 50 | 20 | 12 | 22 |
| SV207F11T | Rp 1" | 420 | 263 | 263 | 420 | 275 | 395 | 395 | 395 | 137 | 129 | 155 | 155 | 120 | 103 | 50 | 20 | 12,5 | 23 |
| SV208F11T | Rp 1" | 445 | 263 | 263 | 445 | 300 | 420 | 420 | 420 | 137 | 129 | 155 | 155 | 120 | 103 | 50 | 20 | 13 | 23 |
| SV209F11T | Rp 1" | 470 | 263 | 263 | 470 | 325 | 445 | 445 | 445 | 137 | 129 | 155 | 155 | 120 | 103 | 50 | 20 | 13,5 | 24 |
| SV211F15T | Rp 1" | 530 | 263 | 263 | 530 | 375 | 505 | 505 | 505 | 137 | 129 | 155 | 155 | 140 | 113 | 50 | 20 | 15 | 31 |
| SV212F15T | Rp 1" | 555 | 263 | 263 | 555 | 400 | 530 | 530 | 530 | 137 | 129 | 155 | 155 | 140 | 113 | 50 | 20 | 15,5 | 31 |
| SV214F22T | Rp 1" | 605 | 281 | 263 | 605 | 450 | 580 | 580 | 580 | 121 | 129 | 176 | 155 | 140 | 113 | 50 | 20 | 16,5 | 33 |
| SV216F22T | Rp 1" | 655 | 281 | 263 | 655 | 500 | - | 630 | 655 | 121 | 129 | 176 | 155 | 140 | 113 | 75 | 25 | 17,5 | 34 |
| SV218F22T | Rp 1" | 705 | 281 | 263 | 705 | 550 | - | 680 | 705 | 121 | 129 | 176 | 155 | 140 | 113 | 75 | 25 | 18,5 | 35 |
| SV220F30T | Rp 1" | 765 | - | 303 | 765 | 600 | - | 740 | 765 | - | 121 | - | 176 | 160 | 123 | 75 | 25 | 20 | 42 |
| SV222F30T | Rp 1" | 815 | - | 303 | 815 | 650 | - | 790 | 815 | - | 121 | - | 176 | 160 | 123 | 75 | 25 | 21 | 43 |
| SV224F30T | Rp 1" | 865 | - | 303 | 865 | 700 | - | 840 | 865 | - | 121 | - | 176 | 160 | 123 | 75 | 25 | 22 | 44 |

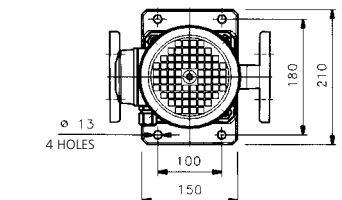
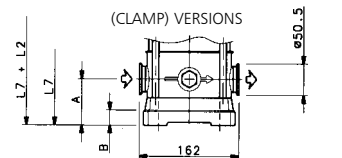

SV4 SERIES (~ 2900 rpm)

MAIN CHARACTERISTICS

Working delivery 2.4 to 8 m³/h.

Maximum operating pressure, including water hammer on suction side:

- Pumps with oval flanges 16 bar.
- Pumps with round flanges 25 bar.

AVAILABLE VERSIONS

- "F" : In-line ports, round flanges from SV402 to SV424.
- "T" : In-line ports, oval flanges from SV402 to SV414.
- "R" : Overlying ports, round flanges from SV405 to SV424.
- "N" : In-line ports, round flanges made of AISI 316 from SV402 to SV424.

TABLE OF MATERIALS

| PART | "F" "R" "T" MATERIALS | "N" MATERIALS |
|---------------------------|------------------------------|---------------|
| Impeller | AISI 316 L | |
| Diffuser and upper spacer | AISI 304 | AISI 316 L |
| Shaft | AISI 304 | AISI 316 |
| Outer sleeve | AISI 304 | AISI 316 L |
| Pump body | AISI 304 | AISI 316 L |
| Shaft sleeve | TUNGSTEN CARBIDE | |
| Bushing | CERAMIC | |
| Mechanical seal | TUNGSTEN CARBIDE/CARBON/EPDM | |
| Elastomers | EPDM | |
| Fill/drain plugs | AISI 316 | |
| Adapter | 250 CAST IRON | |
| Coupling | ALUMINIUM | |
| Coupling protection | AISI 304 | |
| Seal holding disk | AISI 304 | AISI 316 L |
| Base mount | ALUMINIUM | |

ELECTRICAL SPECIFICATIONS

| PUMP TYPE | MOTOR POWER | | | INPUT CURRENT | | | | CAPACITOR | | Is/In | | |
|-----------|-------------|------|-----|---------------|----------|----------|-------------|-----------|-----|--------------|-------------------|--------------------|
| | | | | In Amp. | | | THREE-PHASE | | | SINGLE-PHASE | THREE-PHASE 230 V | SINGLE-PHASE 230 V |
| | | | | Δ | Y | Δ | | | | | | |
| | kW | T | M | 220-240V | 380-415V | 380-415V | 220-240V | | | | | |
| SV402F03T | 0,37 | 71R | 71R | 2,30 | 1,33 | - | 2,64-2,72 | 14 | 450 | 4,23 | 3,08 | |
| SV403F05T | 0,55 | 71 | 71 | 2,48 | 1,43 | - | 3,89-4,05 | 16 | 450 | 5,95 | 3,34 | |
| SV404F07T | 0,75 | 80R | 80R | 3,50 | 2,02 | - | 5,22-4,97 | 20 | 450 | 5,81 | 3,55 | |
| SV405F11T | 1,1 | 80 | 80 | 4,52 | 2,61 | - | 7,07-6,81 | 30 | 450 | 6,78 | 3,80 | |
| SV406F11T | 1,1 | 80 | 80 | 4,52 | 2,61 | - | 7,07-6,81 | 30 | 450 | 6,78 | 3,80 | |
| SV407F11T | 1,1 | 80 | 80 | 4,52 | 2,61 | - | 7,07-6,81 | 30 | 450 | 6,78 | 3,80 | |
| SV408F15T | 1,5 | 90R | 90R | 5,98 | 3,45 | - | 9,32-8,63 | 40 | 450 | 7,04 | 3,45 | |
| SV409F15T | 1,5 | 90R | 90R | 5,98 | 3,45 | - | 9,32-8,63 | 40 | 450 | 7,04 | 3,45 | |
| SV411F22T | 2,2 | 90R | 90 | 8,71 | 5,03 | - | 13,3-12,6 | 50 | 450 | 7,32 | 3,45 | |
| SV413F22T | 2,2 | 90R | 90 | 8,71 | 5,03 | - | 13,3-12,6 | 50 | 450 | 7,32 | 3,45 | |
| SV414F30T | 3 | 100R | - | 10,8 | 6,22 | - | - | - | - | 6,81 | - | |
| SV416F30T | 3 | 100R | - | 10,8 | 6,22 | - | - | - | - | 6,81 | - | |
| SV418F30T | 3 | 100R | - | 10,8 | 6,22 | - | - | - | - | 6,81 | - | |
| SV420F40T | 4 | 112R | - | - | - | 8,14 | - | - | - | 7,86 | - | |
| SV422F40T | 4 | 112R | - | - | - | 8,14 | - | - | - | 7,86 | - | |
| SV424F40T | 4 | 112R | - | - | - | 8,14 | - | - | - | 7,86 | - | |

* R = Reduced size of motor casing as compared to shaft extension and flange.

DIMENSIONS AND WEIGHTS

| PUMP TYPE | DNA DNM | DIMENSIONS IN mm | | | | | | | | | | | | | | WEIGHT (kg) | | | |
|-----------|----------|------------------|-----------------|----------------|-----|-----|-----|-----|-----|----------------|---------------|----------------|---------------|-----|-----|-------------|----|------|---------------|
| | | L1 | L2 SINGLE-PHASE | L2 THREE-PHASE | L3 | L4 | L5 | L6 | L7 | M SINGLE-PHASE | M THREE-PHASE | M SINGLE-PHASE | M THREE-PHASE | D2 | H | A | B | PUMP | ELECTRIC PUMP |
| SV402F03T | Rp 1 1/4 | 285 | 209 | 209 | - | - | 260 | 260 | 260 | 111 | 111 | 120 | 120 | 105 | 93 | 50 | 20 | 9,5 | 17,5 |
| SV403F05T | Rp 1 1/4 | 310 | 231 | 231 | - | - | 285 | 285 | 285 | 121 | 121 | 140 | 140 | 105 | 93 | 50 | 20 | 10 | 18,5 |
| SV404F07T | Rp 1 1/4 | 345 | 226 | 226 | - | - | 320 | 320 | 320 | 121 | 121 | 140 | 140 | 120 | 103 | 50 | 20 | 11 | 21 |
| SV405F11T | Rp 1 1/4 | 370 | 263 | 263 | 370 | 225 | 345 | 345 | 345 | 137 | 129 | 155 | 155 | 120 | 103 | 50 | 20 | 11,5 | 22 |
| SV406F11T | Rp 1 1/4 | 395 | 263 | 263 | 395 | 250 | 370 | 370 | 370 | 137 | 129 | 155 | 155 | 120 | 103 | 50 | 20 | 12 | 22 |
| SV407F11T | Rp 1 1/4 | 420 | 263 | 263 | 420 | 275 | 395 | 395 | 395 | 137 | 129 | 155 | 155 | 120 | 103 | 50 | 20 | 12,5 | 23 |
| SV408F15T | Rp 1 1/4 | 455 | 263 | 263 | 455 | 300 | 430 | 430 | 430 | 137 | 129 | 155 | 155 | 140 | 113 | 50 | 20 | 13,5 | 29 |
| SV409F15T | Rp 1 1/4 | 480 | 263 | 263 | 480 | 325 | 455 | 455 | 455 | 137 | 129 | 155 | 155 | 140 | 113 | 50 | 20 | 14 | 30 |
| SV411F22T | Rp 1 1/4 | 530 | 281 | 263 | 530 | 375 | 505 | 505 | 505 | 121 | 129 | 176 | 155 | 140 | 113 | 50 | 20 | 15 | 32 |
| SV413F22T | Rp 1 1/4 | 580 | 281 | 263 | 580 | 425 | 555 | 555 | 555 | 121 | 129 | 176 | 155 | 140 | 113 | 50 | 20 | 16 | 33 |
| SV414F30T | Rp 1 1/4 | 615 | - | 303 | 615 | 450 | 590 | 590 | 590 | - | 121 | - | 176 | 160 | 123 | 50 | 20 | 17 | 39 |
| SV416F30T | Rp 1 1/4 | 665 | - | 303 | 665 | 500 | - | 640 | 665 | - | 121 | - | 176 | 160 | 123 | 75 | 25 | 18 | 40 |
| SV418F30T | Rp 1 1/4 | 715 | - | 303 | 715 | 550 | - | 690 | 715 | - | 121 | - | 176 | 160 | 123 | 75 | 25 | 19 | 41 |
| SV420F40T | Rp 1 1/4 | 765 | - | 307 | 765 | 600 | - | 740 | 765 | - | 133 | - | 193 | 160 | 123 | 75 | 25 | 20 | 58 |
| SV422F40T | Rp 1 1/4 | 815 | - | 307 | 815 | 650 | - | 790 | 815 | - | 133 | - | 193 | 160 | 123 | 75 | 25 | 21 | 59 |
| SV424F40T | Rp 1 1/4 | 865 | - | 307 | 865 | 700 | - | 840 | 865 | - | 133 | - | 193 | 160 | 123 | 75 | 25 | 22 | 60 |

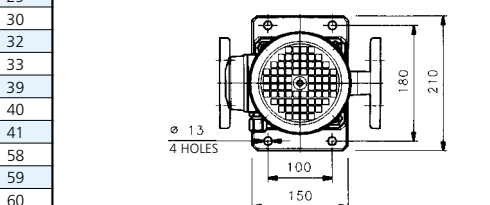
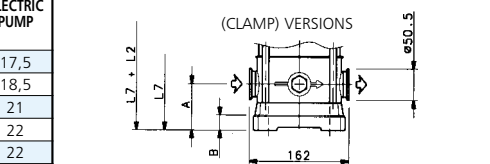
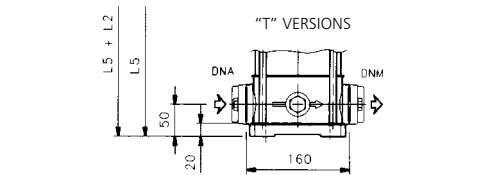
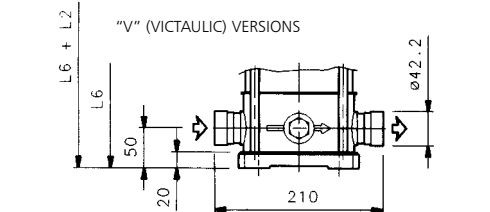
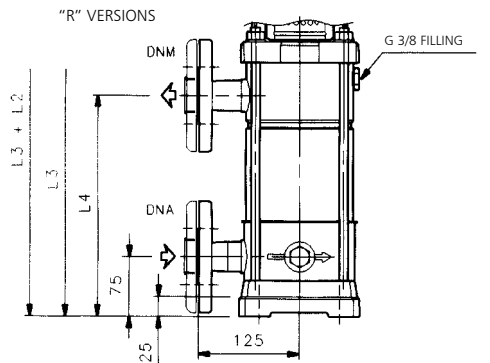
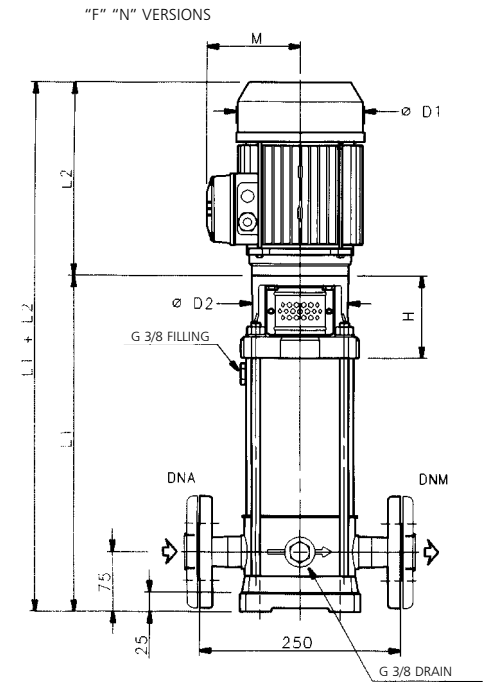

SV

SV8 SERIES (~ 2900 rpm)

MAIN CHARACTERISTICS

Working delivery 6 to 14 m³/h

Maximum operating pressure, including water hammer on suction side:

- Pumps with oval flanges 16 bar.
- Pumps with round flanges 25 bar.

AVAILABLE VERSIONS

- "F" : In-line ports, round flanges from SV802 to SV816.
- "T" : In-line ports, oval flanges from SV802 to SV811.
- "R" : Overlaying ports, round flanges from SV803 to SV816.
- "N" : In-line ports, round flanges made of AISI 316 from SV802 to SV816.

TABLE OF MATERIALS

| PART | "F" "R" "T" MATERIALS | "N" MATERIALS |
|---------------------------|--|---------------|
| Impeller | AIS I 316 L | |
| Diffuser and upper spacer | AISI 304 | AISI 316 L |
| Shaft | AISI 304 | AISI 316 |
| Outer sleeve | AISI 304 | AISI 316 L |
| Pump body | AISI 304 | AISI 316 L |
| Shaft sleeve | TUNGSTEN CARBIDE | |
| Bushing | CERAMIC | |
| Mechanical seal | TUNGSTEN CARBIDE/CARBON/EPDM | |
| Elastomers | EPDM | |
| Fill/drain plugs | AIS I 316 | |
| Adapter | 250 CAST IRON | |
| Coupling | ALUMINIUM UP TO 4 kW 200 CAST IRON FOR HIGHER POWER | |
| Coupling protection | AIS I 304 | |
| Seal holding disk | AISI 304 | AISI 316 L |
| Base mount | ALUMINIUM | |

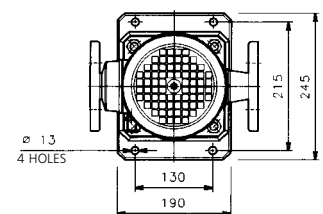
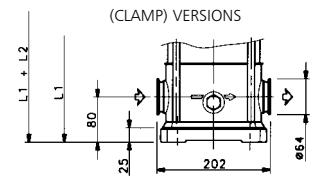
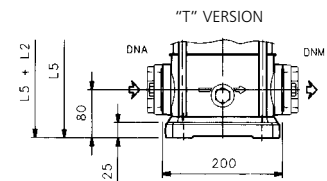
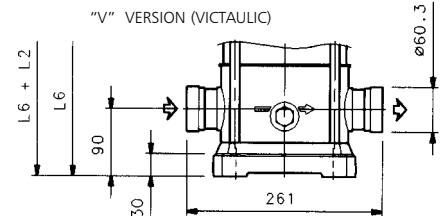
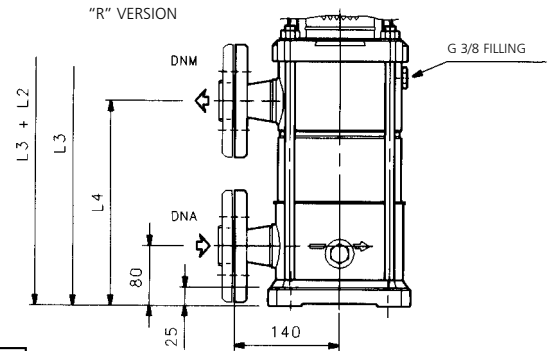
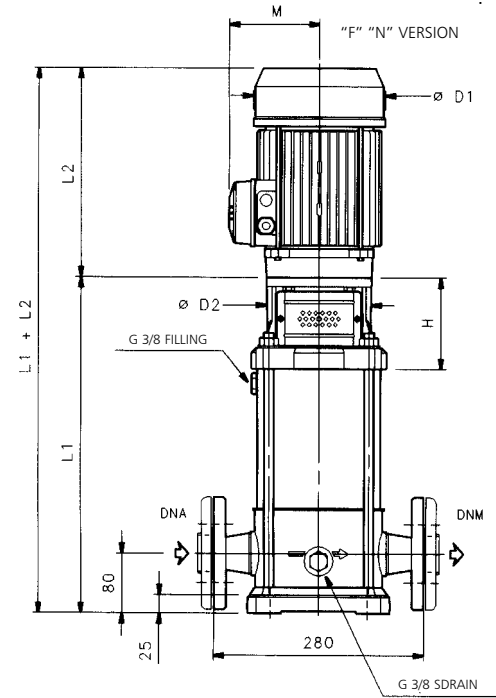

ELECTRICAL SPECIFICATIONS

| PUMP TYPE | MOTOR POWER | | | INPUT CURRENT In Amp. | | | | | CAPACITOR | | Is/In | |
|-----------|-------------|------|-----|-----------------------|------------|------------|--------------|-------------------------|-----------|------|--------------------|----------|
| | | | | THREE-PHASE | | | SINGLE-PHASE | THREE-PHASE 230 V 400 V | | | SINGLE-PHASE 230 V | |
| | | | | Δ 220-240V | Y 380-415V | Δ 380-415V | | | | | | 220-240V |
| SV802F11T | 1,1 | 80 | 80 | 4,52 | 2,61 | - | 7,07-6,81 | 30 | 450 | 6,78 | 3,80 | |
| SV803F15T | 1,5 | 90R | 90R | 5,98 | 3,45 | - | 9,32-8,63 | 40 | 450 | 7,04 | 3,45 | |
| SV804F22T | 2,2 | 90R | 90 | 8,71 | 5,03 | - | 13,3-12,6 | 50 | 450 | 7,32 | 3,45 | |
| SV805F22T | 2,2 | 90R | 90 | 8,71 | 5,03 | - | 13,3-12,6 | 50 | 450 | 7,32 | 3,45 | |
| SV806F30T | 3 | 100R | - | 10,8 | 6,22 | - | - | - | - | 6,81 | - | |
| SV808F40T | 4 | 112R | - | - | - | 8,14 | - | - | - | 7,86 | - | |
| SV809F40T | 4 | 112R | - | - | - | 8,14 | - | - | - | 7,86 | - | |
| SV811F55T | 5,5 | 132R | - | - | - | 11,0 | - | - | - | 7,71 | - | |
| SV812F55T | 5,5 | 132R | - | - | - | 11,0 | - | - | - | 7,71 | - | |
| SV814F75T | 7,5 | 132R | - | - | - | 14,6 | - | - | - | 7,62 | - | |
| SV816F75T | 7,5 | 132R | - | - | - | 14,6 | - | - | - | 7,62 | - | |

* R = Reduced size of motor casing as compared to shaft extension and flange.

DIMENSIONS AND WEIGHTS

| PUMP TYPE | DNA DNM | DIMENSIONS IN mm | | | | | | | | | | | | | WEIGHT (kg) | |
|-----------|----------|------------------|-----------------|----------------|-----|-----|-----|-----|----------------|-------------|-----------------|-------------|-----|-----|-------------|---------------|
| | | L1 | SINGLE-PHASE L2 | THREE-PHASE L2 | L3 | L4 | L5 | L6 | M SINGLE-PHASE | THREE-PHASE | D1 SINGLE-PHASE | THREE-PHASE | D2 | H | PUMP | ELECTRIC PUMP |
| SV802F11T | Rp 1 1/2 | 363 | 263 | 263 | - | - | 363 | 373 | 137 | 129 | 155 | 155 | 120 | 112 | 15 | 25 |
| SV803F15T | Rp 1 1/2 | 411 | 263 | 263 | 411 | 236 | 411 | 421 | 137 | 129 | 155 | 155 | 140 | 122 | 16 | 32 |
| SV804F22T | Rp 1 1/2 | 449 | 281 | 263 | 449 | 274 | 449 | 459 | 121 | 129 | 176 | 155 | 140 | 122 | 17 | 34 |
| SV805F22T | Rp 1 1/2 | 487 | 281 | 263 | 487 | 312 | 487 | 497 | 121 | 129 | 176 | 155 | 140 | 122 | 18 | 35 |
| SV806F30T | Rp 1 1/2 | 535 | - | 303 | 535 | 350 | 535 | 545 | - | 121 | - | 176 | 160 | 132 | 20 | 42 |
| SV808F40T | Rp 1 1/2 | 611 | - | 307 | 611 | 426 | 611 | 621 | - | 133 | - | 193 | 160 | 132 | 20 | 58 |
| SV809F40T | Rp 1 1/2 | 649 | - | 307 | 649 | 464 | 649 | 659 | - | 133 | - | 193 | 160 | 132 | 21 | 59 |
| SV811F55T | Rp 1 1/2 | 745 | - | 374 | 745 | 540 | 745 | 755 | - | 151 | - | 220 | 300 | 152 | 28 | 74 |
| SV812F55T | Rp 1 1/2 | 783 | - | 374 | 783 | 578 | - | 793 | - | 151 | - | 220 | 300 | 152 | 29 | 75 |
| SV814F75T | Rp 1 1/2 | 859 | - | 374 | 859 | 654 | - | 869 | - | 151 | - | 220 | 300 | 152 | 31 | 81 |
| SV816F75T | Rp 1 1/2 | 935 | - | 374 | 935 | 730 | - | 945 | - | 151 | - | 220 | 300 | 152 | 32 | 82 |

SV16 SERIES (~ 2900 rpm)

MAIN CHARACTERISTICS

Working delivery 8 to 24 m³/h.

Maximum operating pressure, including water hammer on suction side:

– Pumps with round flanges 25 bar.

AVAILABLE VERSIONS

– “F” : In-line ports, round flanges from SV1602 to SV1615.

– “N” : In-line ports, round flanges in AISI 316 from SV1602 to SV1615.

TABLE OF MATERIALS

| PART | “F” MATERIALS | “N” MATERIALS |
|---------------------------|--|---------------|
| Impeller | AISI 316 L | |
| Diffuser and upper spacer | AISI 304 | AISI 316 L |
| Shaft | AISI 304 | AISI 316 |
| Outer sleeve | AISI 304 | AISI 316 L |
| Pump body | AISI 304 | AISI 316 L |
| Shaft sleeve | TUNGSTEN CARBIDE | |
| Bushing | CERAMIC | |
| Mechanical seal | TUNGSTEN CARBIDE/CARBON/EPDM | |
| Elastomers | EPDM | |
| Fill/drain plugs | AISI 316 | |
| Adapter | 250 CAST IRON | |
| Coupling | Aluminium UP TO 4 kW 200 CAST IRON FOR HIGHER POWER | |
| Coupling protection | AISI 304 | |
| Seal holding disk | AISI 304 | AISI 316 L |
| Base mount | ALUMINIUM | |

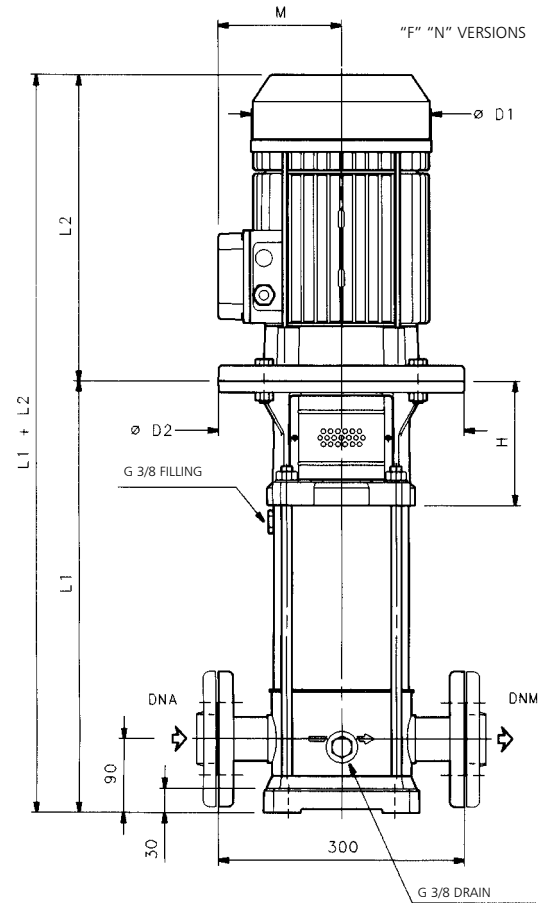

ELECTRICAL SPECIFICATIONS

| PUMP TYPE | MOTOR POWER | | | INPUT CURRENT In Amp. | | | | CAPACITOR | | Is/In | |
|-------------|-------------|------|----|-----------------------|------------|------------|--------------|-----------|-----|-------------------------|--------------------|
| | | | | THREE-PHASE | | | SINGLE-PHASE | | | THREE-PHASE 230 V 400 V | SINGLE-PHASE 230 V |
| | | | | Δ 220-240V | Y 380-415V | Δ 380-415V | | | | | |
| SV1602F22T | 2,2 | 90R | 90 | 8,71 | 5,03 | – | 13,3-12,6 | 50 | 450 | 7,32 | 3,45 |
| SV1603F30T | 3 | 100R | – | 10,8 | 6,22 | – | – | – | – | 6,81 | – |
| SV1604F40T | 4 | 112R | – | – | – | 8,14 | – | – | – | 7,86 | – |
| SV1605F55T | 5,5 | 132R | – | – | – | 11,0 | – | – | – | 7,71 | – |
| SV1606F55T | 5,5 | 132R | – | – | – | 11,0 | – | – | – | 7,71 | – |
| SV1607F75T | 7,5 | 132R | – | – | – | 14,6 | – | – | – | 7,62 | – |
| SV1608F75T | 7,5 | 132R | – | – | – | 14,6 | – | – | – | 7,62 | – |
| SV1610F110T | 11 | 160R | – | – | – | 21,2 | – | – | – | 8,75 | – |
| SV1612F110T | 11 | 160R | – | – | – | 21,2 | – | – | – | 8,75 | – |
| SV1614F150T | 15 | 160 | – | – | – | 28,6 | – | – | – | 8,56 | – |
| SV1615F150T | 15 | 160 | – | – | – | 28,6 | – | – | – | 8,56 | – |

* R = Reduced size of motor casing as compared to shaft extension and flange.

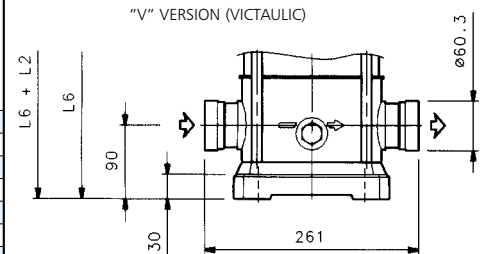

(CLAMP) VERSIONS

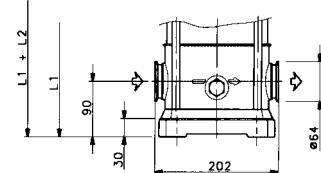

ELECTRICAL SPECIFICATIONS

| PUMP TYPE | DNA DNM | DIMENSIONS IN mm | | | | | | | | | | | | WEIGHT (kg) | | |
|-------------|---------|------------------|-----------------|----------------|----|----|----|-----|----------------|---------------|-----------------|----------------|-----|-------------|------|---------------|
| | | L1 | L2 SINGLE-PHASE | L2 THREE-PHASE | L3 | L4 | L5 | L6 | M SINGLE-PHASE | M THREE-PHASE | D1 SINGLE-PHASE | D1 THREE-PHASE | D2 | H | PUMP | ELECTRIC PUMP |
| SV1602F22T | Rp 2" | 383 | 281 | 263 | – | – | – | 383 | 121 | 129 | 176 | 155 | 140 | 122 | 15 | 32 |
| SV1603F30T | Rp 2" | 431 | – | 303 | – | – | – | 431 | – | 121 | – | 176 | 160 | 132 | 16 | 38 |
| SV1604F40T | Rp 2" | 469 | – | 307 | – | – | – | 469 | – | 133 | – | 193 | 160 | 132 | 17,5 | 55 |
| SV1605F55T | Rp 2" | 527 | – | 374 | – | – | – | 527 | – | 151 | – | 220 | 300 | 152 | 22 | 68 |
| SV1606F55T | Rp 2" | 565 | – | 374 | – | – | – | 565 | – | 151 | – | 220 | 300 | 152 | 23 | 69 |
| SV1607F75T | Rp 2" | 603 | – | 374 | – | – | – | 603 | – | 151 | – | 220 | 300 | 152 | 24 | 74 |
| SV1608F75T | Rp 2" | 641 | – | 374 | – | – | – | 641 | – | 151 | – | 220 | 300 | 152 | 25 | 75 |
| SV1610F110T | Rp 2" | 749 | – | 427 | – | – | – | 749 | – | 191 | – | 257 | 350 | 184 | 34 | 119 |
| SV1612F110T | Rp 2" | 825 | – | 427 | – | – | – | 825 | – | 191 | – | 257 | 350 | 184 | 36 | 121 |
| SV1614F150T | Rp 2" | 901 | – | 488 | – | – | – | 901 | – | 232 | – | 310 | 350 | 184 | 38 | 130 |
| SV1615F150T | Rp 2" | 939 | – | 488 | – | – | – | 939 | – | 232 | – | 310 | 350 | 184 | 39 | 131 |

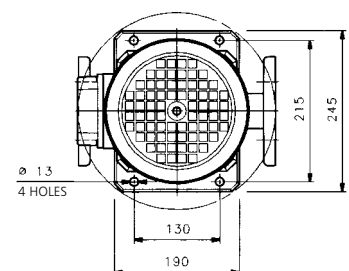

SV30 SERIES (~ 2900 rpm)

MAIN CHARACTERISTICS

Working delivery 15 to 39 m³/h.

Maximum operating pressure, including water hammer on suction side:

- Up to SV3006 16 bar.
- From SV3007 to SV3012 25 bar.

AVAILABLE VERSIONS

- “F” : In-line ports, round flanges from SV3002 to SV3012.
- “N” : In-line ports, round flanges in AISI 316 from SV3002 to SV3012.

TABLE OF MATERIALS

| PART | “F” MATERIALS | “N” MATERIALS |
|---------------------------|-----------------------------|----------------------|
| Impeller | AISI 316 L | |
| Diffuser and upper spacer | AISI 316 L | |
| Shaft | AISI 431 | AISI 316 |
| Outer sleeve | AISI 304 | AISI 316 L |
| Pump body | 250 CAST IRON | CF - 8M (AISI 316 L) |
| Shaft sleeve | TUNGSTEN CARBIDE | |
| Bushing | CERAMIC | |
| Mechanical seal | SILICON/CARBIDE/CARBON/EPDM | |
| Elastomers | EPDM | |
| Fill/drain plugs | NICKEL PLATED BRASS | AISI 316 |
| Spider | 250 CAST IRON | |
| Coupling | 200 CAST IRON | |
| Coupling protection | AISI 304 | |
| Seal holding disk | – | AISI 316 L |

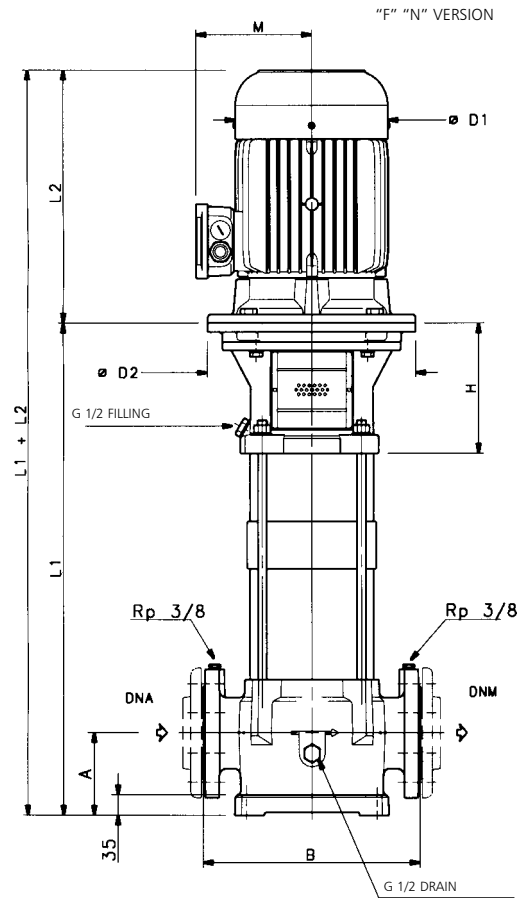

ELECTRICAL SPECIFICATIONS

| PUMP TYPE | MOTOR POWER | | INPUT CURRENT In Amp. | | | Is/In |
|-------------|-------------|------|-----------------------|-------------|-------------|-------|
| | | | THREE-PHASE | | | |
| | | | Δ 220-240 V | Y 380-415 V | Δ 380-415 V | |
| SV3002F40T | 4 | 112R | – | – | 8,14 | 7,86 |
| SV3003F55T | 5,5 | 132R | – | – | 11,0 | 7,71 |
| SV3004F75T | 7,5 | 132R | – | – | 14,6 | 7,62 |
| SV3005F110T | 11 | 160R | – | – | 21,2 | 8,75 |
| SV3006F110T | 11 | 160R | – | – | 21,2 | 8,75 |
| SV3007F150T | 15 | 160 | – | – | 28,6 | 8,56 |
| SV3008F150T | 15 | 160 | – | – | 28,6 | 8,56 |
| SV3009F150T | 15 | 160 | – | – | 28,6 | 8,56 |
| SV3010F185T | 18,5 | 160 | – | – | 34,2 | 8,80 |
| SV3011F185T | 18,5 | 160 | – | – | 34,2 | 8,80 |
| SV3012F220T | 22 | 180R | – | – | 40,3 | 8,61 |

* R = Reduced size of motor casing as compared to shaft extension and flange.

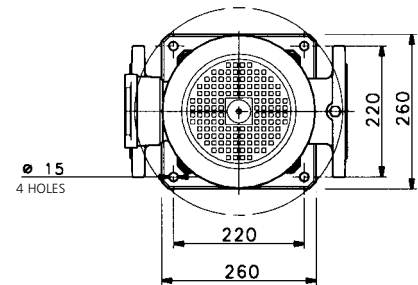

DIMENSIONS AND WEIGHTS

| PUMP TYPE | DNA DNM | DIMENSIONS IN mm | | | | | | | | WEIGHT (kg) | |
|-------------|---------|------------------|-----|-----|-----|-----|-----|-----|-----|-------------|---------------|
| | | L1 | L2 | A | B | M | D1 | D2 | H | PUMP | ELECTRIC PUMP |
| SV3002F40T | 65 | 588 | 307 | 105 | 320 | 133 | 193 | 160 | 170 | 48 | 78 |
| SV3003F55T | 65 | 680 | 374 | 105 | 320 | 151 | 220 | 300 | 190 | 56 | 102 |
| SV3004F75T | 65 | 752 | 374 | 105 | 320 | 151 | 220 | 300 | 190 | 59 | 109 |
| SV3005F110T | 65 | 856 | 427 | 105 | 320 | 191 | 257 | 350 | 222 | 70 | 155 |
| SV3006F110T | 65 | 1120 | 427 | 105 | 320 | 191 | 257 | 350 | 222 | 83 | 168 |
| SV3007F150T | 65 | 1192 | 488 | 105 | 320 | 232 | 310 | 350 | 222 | 86 | 178 |
| SV3008F150T | 65 | 1264 | 488 | 105 | 320 | 232 | 310 | 350 | 222 | 89 | 181 |
| SV3009F150T | 65 | 1336 | 488 | 105 | 320 | 232 | 310 | 350 | 222 | 93 | 185 |
| SV3010F185T | 65 | 1408 | 532 | 105 | 320 | 232 | 310 | 350 | 222 | 96 | 195 |
| SV3011F185T | 65 | 1480 | 532 | 105 | 320 | 232 | 310 | 350 | 222 | 99 | 198 |
| SV3012F220T | 65 | 1552 | 532 | 105 | 320 | 232 | 310 | 350 | 222 | 102 | 216 |

SV60 SERIES (~ 2900 rpm)

MAIN CHARACTERISTICS

Working delivery 24 to 72 m³/h.

Maximum operating pressure, including water hammer on suction side:

– 16 bar.

AVAILABLE VERSIONS

– “F” : In-line ports, round flanges from SV6002 to SV6008.

– “N” : In-line ports, round flanges made of AISI 316 from SV6002 to SV6008.

TABLE OF MATERIALS

| PART | “F” MATERIALS | “N” MATERIALS |
|---------------------------|-----------------------------|----------------------|
| Impeller | AISI 316 L | |
| Diffuser and upper spacer | AISI 316 L | |
| Shaft | AISI 431 | AISI 316 |
| Outer sleeve | AISI 304 | AISI 316 L |
| Pump body | 250 CAST IRON | CF - 8M (AISI 316 L) |
| Shaft sleeve | TUNGSTEN CARBIDE | |
| Bushing | CERAMIC | |
| Mechanical seal | SILICON CARBIDE/CARBON/EPDM | |
| Elastomers | EPDM | |
| Fill/drain plugs | NICKEL PLATED BRASS | AISI 316 |
| Adapter | 250 CAST IRON | |
| Coupling | 200 CAST IRON | |
| Coupling protection | AISI 304 | |
| Seal holding disk | – | AISI 316 L |

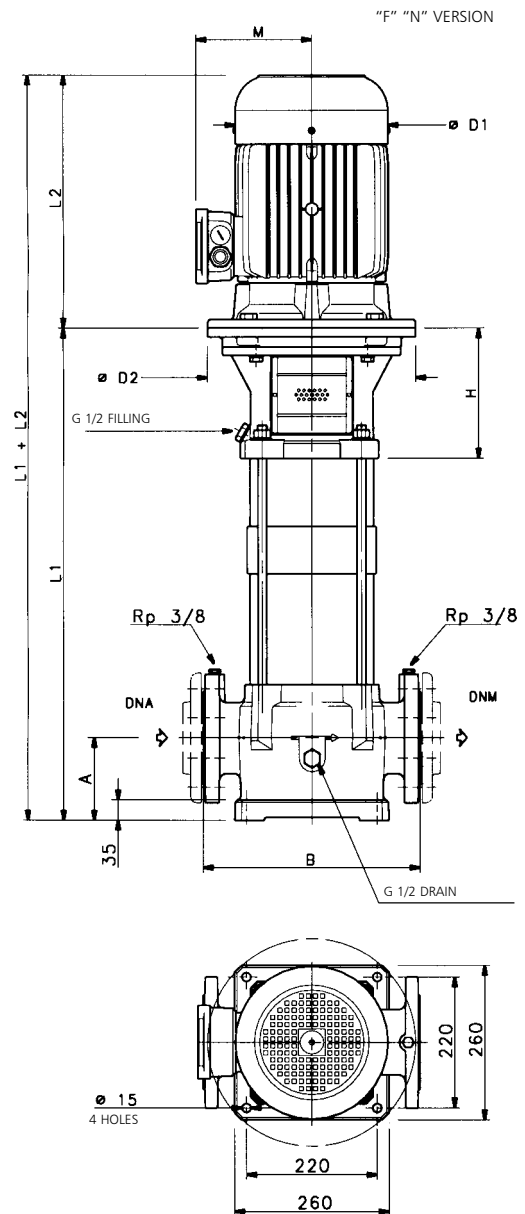

ELECTRICAL SPECIFICATIONS

| PUMP TYPE | MOTOR POWER | | INPUT CURRENT In Amp. | | | Is/In |
|--------------|-------------|------|-----------------------|----------------|----------------|-------|
| | | | THREE-PHASE | | | |
| | | | Δ 220-240 V | Y 380-415 V | Δ 380-415 V | |
| SV6002 F55T | 5,5 | 132R | – | – | 11,0 | 7,71 |
| SV6003 F75T | 7,5 | 132R | – | – | 14,6 | 7,72 |
| SV6004 F110T | 11 | 160R | – | – | 21,2 | 8,75 |
| SV6005 F150T | 15 | 160 | – | – | 28,6 | 8,56 |
| SV6006 F150T | 15 | 160 | – | – | 28,6 | 8,56 |
| SV6007 F185T | 18,5 | 160 | – | – | 34,2 | 8,80 |
| SV6008 F220T | 22 | 180R | – | – | 40,3 | 8,61 |

* R = Reduced size of motor casing as compared to shaft extension and flange.

DIMENSIONS AND WEIGHTS

| PUMP TYPE | DNA DNM | DIMENSIONS IN mm | | | | | | | | WEIGHT (kg) | |
|--------------|------------|------------------|-----|-----|-----|-----|-----|-----|-----|-------------|---------------|
| | | L1 | L2 | A | B | M | D1 | D2 | H | PUMP | ELECTRIC PUMP |
| SV6002 F55T | 100 | 658 | 374 | 140 | 365 | 151 | 220 | 300 | 190 | 57 | 103 |
| SV6003 F75T | 100 | 730 | 374 | 140 | 365 | 151 | 220 | 300 | 190 | 60 | 110 |
| SV6004 F110T | 100 | 834 | 427 | 140 | 365 | 191 | 257 | 350 | 222 | 71 | 156 |
| SV6005 F150T | 100 | 906 | 488 | 140 | 365 | 232 | 310 | 350 | 222 | 74 | 166 |
| SV6006 F150T | 100 | 1170 | 488 | 140 | 365 | 232 | 310 | 350 | 222 | 87 | 179 |
| SV6007 F185T | 100 | 1242 | 532 | 140 | 365 | 232 | 310 | 350 | 222 | 90 | 189 |
| SV6008 F220T | 100 | 1314 | 532 | 140 | 365 | 232 | 310 | 350 | 222 | 94 | 208 |