

Parallel Shaft Mounted Gear Units

Paralel Şaft Montajlı Redüktör

PD/PM SERIES

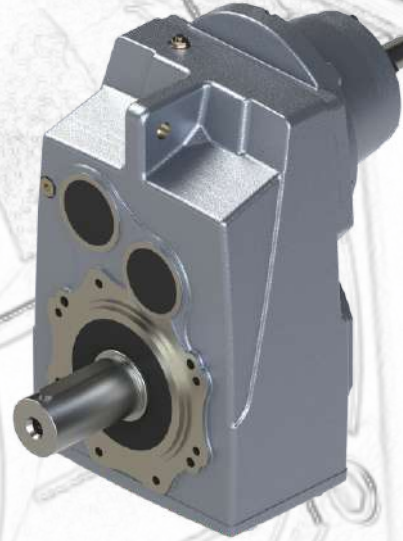
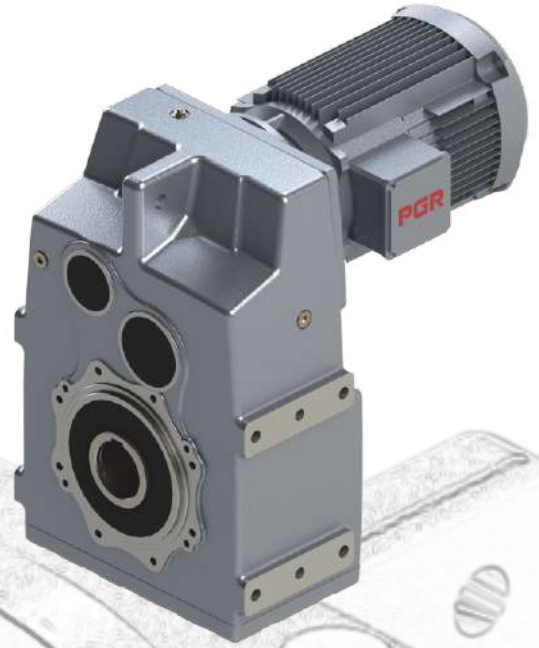

K.No: PD/PM 05/2016

TR EN

İÇİNDEKİLER / CONTENTS

Giriş / Intro.....	2
Teknik Bilgiler / Explanatory Notes.....	3 - 7
Radyal Yük Hesabı / Calculation of Radial Loads.....	8 - 11
Kısaltmalar / Abbreviations.....	12
PD\PM Tanıtımı / Description of PD\PM.....	13
W ve IEC Adaptör Kullanımı / Using W and IEC Adaptor.....	14
Kullanım Alanları / Application Areas.....	15 - 19
Kullanılan Terimler / Terminology.....	20 - 21
PD\PM Modüler Sistemi / Modular System of PD\PM.....	22
Mevcut Dizaynlara Genel Bakış / Overview of Available Designs.....	23
Ürünlerimiz / Products.....	24 - 31
Sipariş Örneği / Ordering Example.....	32
Montaj Pozisyonları ve Yağ Markaları / Mounting Positions and Lubrication Marks.....	33 - 39
Yağ Miktar Tablosu / Lubrication Levels.....	40 - 41
Kilit / Backstop.....	42
Toleranslar / Tolerances.....	43
Servo Motor Adaptörü / Servomotors Adapter.....	44
PD\PM B14 Flanşlı Ölçü Tablosu / Dimension Table of PD\PM with B14 Flange.....	45
Montaj Ölçüleri / Dimensions of Installing.....	46
Merkezeleme Pimi Ölçü Tablosu / Dimension Tables of Guide Pins.....	47
Konik Sıkırtma / Shrink Disc.....	48 - 50
Güçlendirilmiş Konik Sıkırtma Kapağı / Cover of Reinforced Shrink Disc.....	51
Şaft Koruma Kapağı Ölçü Tablosu / Dimension Table of Cover.....	52
Normal ve Güçlendirilmiş Lastik Takoz / Normal and Reinforced Design of Rubber Buffer.....	53
IP 66 Uygulaması / Protection IP 66	54
Güçlendirilmiş B5 Flanşlı Ölçü Tablosu / Dimension table of Reinforced B5 Flange.....	55 - 57
Su Soğutmalı / Water Cooling.....	58
İlave Yağ Hacmi ve Yağ Tankı / Additional Lubrication Volume and Oil Tank.....	59
Yağ Soğutmalı / Oil Cooling.....	60
Mekanik Keçe / Mechanical Seal.....	61
Çektirme Ölçü Tablosu / Dimension Table of Fixing Elements.....	62 - 63
Motor Platformu / Installation of Motor Platform.....	64 - 66
Motorlu Seçim Tabloları / Selection Tables of Gearedmotors.....	69 - 108
Ölçü Tabloları / Dimension Tables	111 - 169
W - IEC Adaptörü Seçim Tabloları / Selection Tables of W and IEC Adapters.....	171 - 193
PD\PM Genel Parça Listeleri / General Part Lists of PD\PM.....	195 - 209
Elektrik Motoru / Electrical Motor.....	210 - 230
Motor Parça Listesi / Motor Part List.....	232 - 237
Fren Parça Listesi / Brake Part List.....	238

TR

KALİTE POLİTİKAMIZ

POLAT GROUP REDÜKTÖR A.Ş. ürünlerinin kalitesinde en iyi yakalamak için; sektöründeki teknolojik gelişmeleri takip etmeyi, pazar payındaki istikrarını sürdürmek için müşterilerinin istek ve beklentilerine eksiksiz ve zamanında cevap vererek, sürekli artan müşteri memnuniyetini sağlamayı, eğitilmiş çalışanlarının performansını huzurlu bir çalışma ortamı sağlayarak arttırmayı ve bu şekilde kalite yönetim sistemini sürekli iyileştirmeyi kalite politikası olarak benimsemiştir.

VİZYONUMUZ

Müşteri ve çalışan memnuniyetini en üst düzeyde tutan, gelişmeleri izleyen değil yaratan bir dünya şirketi olmaktır.

MİSYONUMUZ

Müşterilerimizin ihtiyaçlarını karşılayacak çözümleri bilgi teknolojilerini kullanarak en verimli ve kaliteli şekilde sunmaktır.

Polat Group Redüktör olarak birçok farklı ürün yelpazesi ile, müşteri ihtiyacını maksimum seviyede karşılamak için eş zamanlı mühendislik yöntemlerini kullanarak çalışmalarını sürdürmektedir. Tasarım faaliyetleri, ürün geliştirme programları ve bilgisayar destekli çalışmalarımız sürekli gelişen bir grafik çizmektedir. Rekabetçi ve güçlü kalite politikamız müşteri yelpazemizi genişletmektedir.

EN

OUR QUALITY POLICY

To achieve the best quality of its products, POLAT GROUP REDÜKTÖR A.Ş. adopts with its own quality politics by following the technological developments of its sector, in order to keep up the stabilization on its own market share ensuring the customers' gladness increasing permanently by answering the customers' wishes and expectations completely at the right time to have the well-educated staffs increase their performance by providing a peaceful working place and making better the quality management system all the time.

OUR VISION

Our vision is to become a world company which meets and surpasses the customer satisfaction and which not only follows the development but also creates the development itself.

OUR MISSION

Our mission is to provide the solutions to our customers in the most efficient and qualified way by making use of the information technologies.

Our reducer group carries out its work using simultaneous engineering methods in order to meet the demands of our customers by presenting several different product ranges. Design and planning activities, product development programmes and computer supporting work show a continuously growing chart. Our competitive and strong quality policy is to develop our customer spectrum.

TR

TEKNİK AÇIKLAMALAR

Dişli Ünitesini Seçme

Bir dişli ünitesini seçerken PGR üç fazlı asenkron AC motorlarını veya tek fazlı AC motorları kullanılır ve teknik olarak kıyaslanabilen motorlar için de geçerlidir. Başka motorlar kullanırken, lütfen PGR'e danışınız. Bir dişli ünitesini seçme ile ilgili aşağıdaki önemli ana esaslara bağlı kalınmazsa, aşırı bir yük durumunun olması muhtemeldir. Bu durumda, tüm garantiler geçersizdir. Şüpheli durumda, lütfen dişli ünitesi tasarımını kontrol etmek için birlikte çalışabileceğiniz teknik bilgilerden sorumlu PGR satış ofisi ile irtibata geçiniz. Karşılıklı çıkarlarımız açısından, dişli ünitelerinde aşırı yüklemenin neden olduğu tüm problemler her durumda, önlenmelidir.

Kriter

Seçme kriteri aşağıdakilerden oluşur:

1. Termal olarak transfer edilebilen güç (termal sınır)

Dişli ünitesinin aşırı ısınmaması için, bu güç transferi (3 saat) daha uzun bir çalışma zamanını aşmamalıdır. Termal olarak transfer edilebilen güç sadece PA/PF 62, PD/PM 62 ve daha büyük (iki kademeli dişli üniteleri için) gövdeler ve PA/PF 73, PD/PM 73, PKD 6390-7390 ve daha büyük gövdeler (üç kademeli dişli üniteleri için) için olası bir sınırı gösterir. Aşağıdaki maddelerden iki veya daha fazlasının geçerli olması durumunda çalışma durumunu kontrol ediniz.

- Ortam sıcaklığı $> 40^{\circ}\text{C}$
- Dönme hızı $n_1 > 1500 \text{ min}^{-1}$
- Motor gücü $P_1 > 100 \text{ kW}$
- W kovanlı ve IEC adaptörlü redüktörler
- Dik olarak montajı yapılan redüktörler (sayfa 34-39)
- Tahvil oranı $i_{top} < 20$ (Polat konik dişli için $i_{top} < 40$)

2. Mekanik olarak transfer edilebilen güç "P"

Bu güç, katalogdaki ilgili tablodaki servis faktörü f_B tarafından göz önüne alınır. Bir sonraki bölüm, gerekli servis faktörünün saptanmasını tanımlar.

Genel olarak, dişli ünitesi ekleme, ısı radyasyonu, dar yer vs gibi özel montaj koşulları olduğunda bize danışınız. Özel ölçüler (veya su soğutucusu) termal aşırı yüküne karşı var olduğunda; lütfen PGR'e danışınız.

Giriş gücü ve servis faktörü

Her bir uygulama için gerekli giriş gücü, hesaplama ile saptanır. Motor anma gücü (P_1), bu giriş gücünden sonra seçilir. Normal olarak, belirli uygulama özel çalışma koşullarına ait güvenlik faktörleri gözleneceği ve anma motor çıkış seviyeleri genellikle standart çıkış seviyesi aralığında olduğu için motorun anma gücü istenilen güçten biraz daha yüksektir.

Montajı yapılacak 3 fazlı bir AC motorun anma gücünü seçerken kısa dönem ve seyrek tork tesirini göz önüne almak gerekmez. Bir frekans inventörü üzerindeki 3 fazlı bir AC motor çalıştırırken ilave faktörler anma çıkış gücünün seçimini etkiler. Motorun aksine, kısa dönem ve seyrek tork tesiri önemli derecede dişli ünitesinin seçimini etkiler. Dişli ünitesi servis faktörü f_B bu kısa dönem ve seyrek tork tesirini ve ayrıca yeterli doğrulukla dişli ünitesi üzerinde etkileri göz önüne alır.

4.sayfadaki **diyagram 1** çalışma saatine veya güne bağlı olarak yük sınıflandırması, devir ve minimum servis faktörü arasındaki ilişkiyi sunmaktadır.

EN

EXPLANATORY NOTES

Selecting Gear Unit

Gear unit selection includes PGR's three-phase AC motor or single phase AC motor and technically equal different motor could be applied. If you intend to use a motor other than PGR please contact PGR. There are some condition for selecting gear unit and these condition must be considered overloading could be happened badly if restrictions are not considered. In these situation, all guarantees could be invalidated. Under suspicious situation please refer to PGR sales office department which is responsible for giving technical information to you.

Conditions

The conditions of selecting gear unit are as the following:

1. Thermal Limit

Thermal transfer power should not be exceeded over running time (3 hours) to prevent overheated gear unit. In larger gear unit size this condition is important and units have thermal limit for instance PA/PF 62 and greater unit size, PA/PF 73, PD/PM 73, PKD 6390-7390. For these problems, you must check ambient and some other conditions which are explained below. In case of any suspicion please contact PGR.

- Ambient temperature $> 40^{\circ}\text{C}$
- Rotational speed $n_1 > 1500 \text{ min}^{-1}$
- Input power $P_1 > 100 \text{ kW}$
- With W-cylinder and IEC adapter gear units
- Vertical mounting position (see page 34-39)
- Reduction ratio $i_{top} < 20$ (for helical-bevel gear units $i_{top} < 40$)

2. Power transfer with service factor "P"

Service factor (f_B) is important for power transfer, determination of minimum service factor will be provided at the following section.

In special operating conditions; eg. heat radiation in bounded field (little space) which is required special devices (oil cooler or water cooler) please contact PGR

Input power and service factor

For every application, the requiring input power could be calculated. After determining input power, the rated motor power (P_1) is selected. Normally motor power is greater than the required input power because the safety factor is used according to operating conditions.

Selecting a motor type is important for right calculation for instance; three phase AC motor which is mounted to gear unit, affecting infrequent torque could not be considered but if you mount three-phase AC motor on frequency inverter latest available factor effects the output power. Besides of motor type short and infrequent torque impression effects selecting gear unit for that service factor is considered.

Diagram 1 which is shown on page 4, presents relation between types of load, revolution per hour and minimum service factor depend on operation hours or day.

TR

SERVİS FAKTÖRÜ

Diyagram 1, günlük çalışma zamanına bağlı gerekli minimum servis faktörü f_B min, 'Z' saatteki çevrimleri, ve uygulama yükü sınıflandırması 'U', 'M', 'H' gösterir. Çalışma düzgünlüğüne ve kütle hız faktörüne bağlı olarak, üç yük sınıflandırması belirlenmiştir. Hareket ettiren makineden gelen etkiler çalışma düzgünlüğü sınıflandırmasında tanımlanırken, kütle hız faktörü en fazla olan yük üzerinde etkili olur.

Not : Elde edilen servis faktörü f_B kullanılan sürücü (tahrik) tipine göre "k" katsayısı ile çarpılır.

k = 1 ; elektrik motoru veya hidromotor,
 k = 1.25 ; çok silindirli içten yanmalı motor,
 k = 1.50 ; tek silindirli içten yanmalı motor

EN

SERVICE FACTOR

Diagram 1 shows requiring minimum service factor depend on revolution per hours 'Z' and types of load 'U', 'M' or 'H'. In the following section the information regarding mass acceleration factor, how it effects and the relation between load classification will be explained. Forces or loads which are applied from driven machin to gear unit while determine load classification, mass acceleration factor is played important role on the high load classification which is designated with 'H' sign.

Note : Service factor f_B which is acquired from diagram should be modified with factor "k" that, depends on driver type.

k = 1 ; hydraulic motor and electrical motor
 k = 1.25 ; multi-cylinder engine
 k = 1.50 ; single-cylinder engine

Diyagram - 1

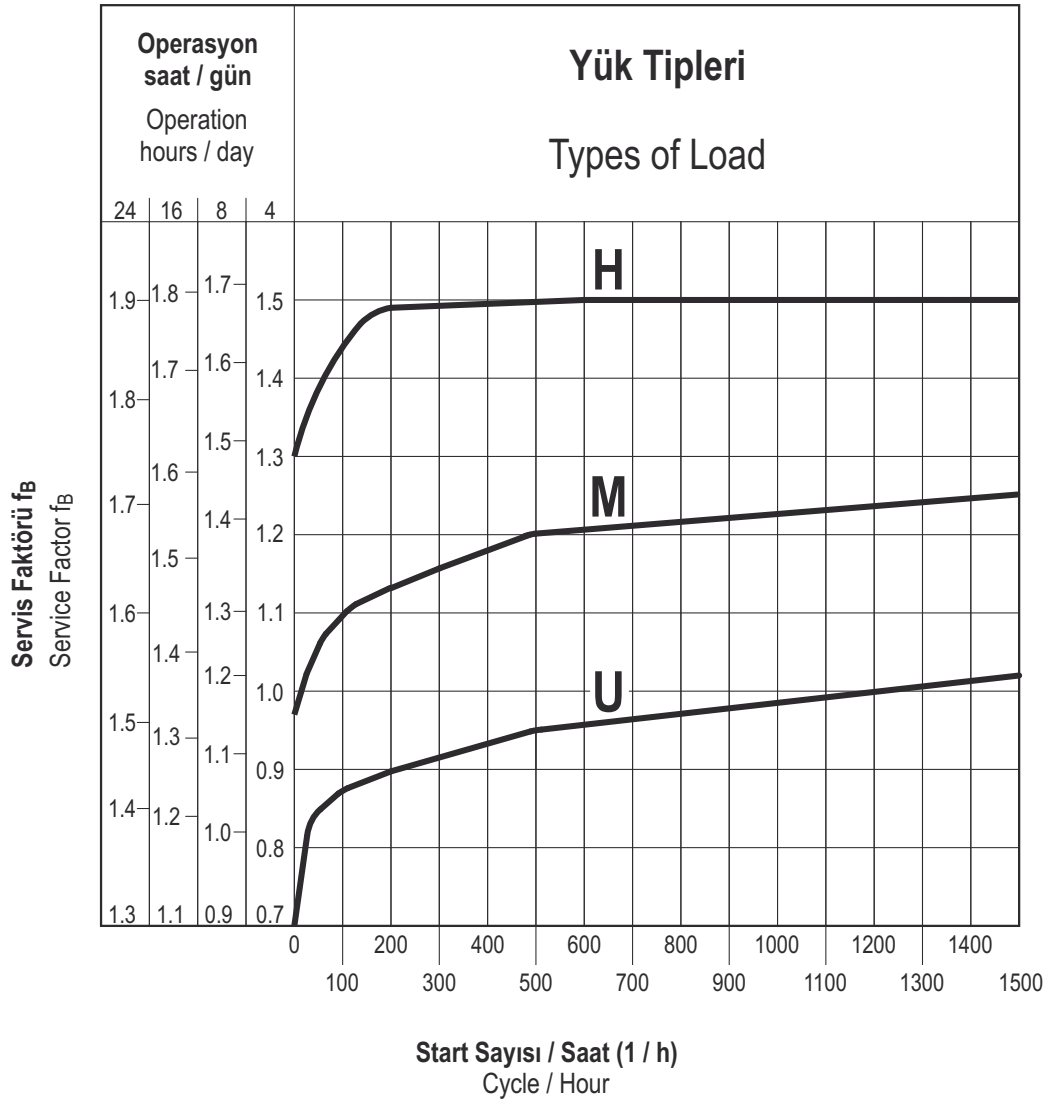

TR

TEKNİK BİLGİLER

Dişli Ünitesini Seçme

Bir çalışmanın sınıflandırılması :

Düzgün çalışma (U)

Küçük karıştırıcılar, asansörler, konveyörler, montaj bantları, doldurma makinaları, bantlı konveyörler, temizleme makinaları, fanlar, test makinaları.

Yumuşak şoklar, düzgün olmayan çalışma (M)

Ağır konveyör bantları, değirmenler, ahır gübre makinaları, vinç hareketli mekanizmalar, bükme makinaları, çimento karıştırıcılar, dişli makinaları, ahşap işleme makinaları için sürücüler, vinçler, kayar kapılar, dengeleme makinaları.

Ağır şoklar, aşırı düzgün olmayan çalışma (H)

Taş kırıcılar, eksantrik presler, doğrayıcılar, presler, taşlama milleri, çekeçli kırıcılar, kağıt öğütücüler, ağır karıştırıcılar, delme makinaları, katlama makinaları, dönen tezgahlar, yatay karıştırıcılar, kesiciler, vibratörler, santrifüj makinaları, döner tablalar.

Yük sınıflandırması, çalışma düzgünlüğünden ve aşağıdaki tabloya göre kütle hız faktörü 'm_{af}' den belirlenir. Burada, çalışma veya kütle hız faktöründen gelen daha yüksek sınıf yük sınıflandırmasında geçerlidir. (Örnek: aşırı düzgün olmayan çalışma ve m_{af} = 3,8 gibi durumda yük sınıfı 'H' olarak belirlenir.

Yük Sınıfı	Çalışma	Kütle hız faktörü
U	Düzgün çalışma	m _{af} ≤ 0.25
M	Düzgün olmayan çalışma	0.25 < m _{af} ≤ 3
H	Aşırı düzgün olmayan çalışma	3 < m _{af} ≤ 10

$$m_{af} = \frac{J_{ex.red}}{J_{mot}} = \frac{J_{ex}}{J_{mot}} \times \left(\frac{1}{i_{ges}} \right)^2$$

i_{ges} = Toplam dişli ünitesi oranı

J_{ex.red} = Hareket motoru üzerindeki azaltılmış tüm dış kütle atalet momenti

J_{ex} = Tüm dış kütle atalet momenti

J_{mot} = Motorun kütle atalet momenti

Kütle hız faktörü m_{af}, çıkış tarafındaki dış kütleler ile giriş tarafındaki yüksek hız kütlelerin arasındaki ilişkiyi gösterir. Kütle hız faktörü, başlatma ve frenleme işlemlerine ve titreşime göre dişli ünitesindeki tork tesir seviyesini önemli derecede etkiler.

Örneğin; bantlı konveyör sistemlerinde dış kütle atalet momenti taşınan ürün kadar yük uygular. m_{af} > 10 ise, transfer elemanlarında büyük bir oynama, yük sınıflamasında belirsizlik varsa veya şüphedeyseniz, PGR'e danışınız.

Servis faktörü f_B, maksimum dişli ünitesi çıkış momenti M_{amax} ile montajlanmış motor gücü P₁, çıkış hızı n₂ ve dişli ünitesi verimi (η) sonucu ortaya çıkan momenti M_a arasındaki ilişkidir.

$$M_2 = \frac{9550 \cdot P_1 \cdot \eta}{n_2} \text{ [Nm]}$$

P₁ [kW], n₂ [min⁻¹]

$$f_B = \frac{M_{amax}}{M_2}$$

EN

EXPLANATORY NOTES

Selecting a Gear Unit

Operation classification;

Uniform application (U)

Small agitators, elevators, conveyors, assembly belts, filling machines, conveyor belts, cleaning machines, fans, testing machines.

Moderate shocks, non-uniform application (M)

Heavy conveyors belts, mills, stall duning machines, crane traveling mechanisms, bending machines, cement mixers, gear pumps, decoilers, tapping units, packaging machines, feed drives for wood processing machines, hoists, winches sliding doors, balancing machines.

Heavy shocks, extreme non-uniform application (H)

Stone crusher, eccentric presses, choppers, presses, spindle grinding mills, hammer mills, shredders, heavy mixers, punching machines, folding machines, rolling stands, tumbling barrels, shears, vibrators, centrifuges, roller tables.

Load classification is obtained from operation class and mass acceleration factor (m_{af}). For this reason in any situation you must use the greater factor for calculation. (Eg; heavy - shock and m_{af} = 3,8 load classification must be 'H')

Load Classification	Operation	Mass Acceleration Factor
U	Uniform application	m _{af} ≤ 0.25
M	Non-uniform application	0.25 < m _{af} ≤ 3
H	Extreme non-uniform application	3 < m _{af} ≤ 10

i_{ges} = Total gear unit ratio

J_{ex.red} = All external mass moment of inertia on the drive motor, reduced

J_{ex} = All external mass moment of inertia

J_{mot} = Mass moment of inertia of the motors

Technically mass acceleration factor m_{af} mass different between external output-side and high speed input-side. m_{af} plays more important role at the level of torque propulsive than in the gear unit..

It is mostly effected at start-up, braking operation and vibration. Please contact PGR where m_{af} is greater than 10 and if there be large fluctions in transfer elements and vibration in the system.

Calculation of service factor is illuminated below. It depends on maximum output moment of gear unit and the output moment which is calculated from motor power, rotation speed and efficiency.

TR

TEKNİK BİLGİLER

$$P_1 = \frac{M_2 \cdot n_2}{9550} \cdot \eta \text{ [kW]}$$

Dişli ünitesini doğru şekilde seçtiğinizde, çıkış ve hız genel açıklamalarından alınan servis faktörü f_B , diyagram 1'e göre minimum servis faktörü $f_{B \text{ min}}$ 'den büyük veya eşittir.

$$f_B \geq f_{B \text{ min}}$$

Helisel ve paralel mil dişli ünitelerinde herbir kademe için çok yüksek bir seviyede verimlilik vardır (herbir kademe için yaklaşık %98 veya $\eta = 0,98$). Bu yüzden hesaplamalarda verim $\eta = 1,0$ alınması yeterli doğru sonuçlara ulaşılmasına yardımcı olur.

W kovanı montajlı (serbest hareket mili) redüktörde çıkış gücü aşağıdaki formülden hesaplanır.

$$P_1 = \frac{M_{\text{amax}} \cdot n_2}{9550 \cdot f_{B \text{ min}}} \cdot \eta \text{ [kW]} \quad M_{\text{amax}} \text{ [Nm]}, n_2 \text{ [min}^{-1} \text{]}$$

Bu formülden hesaplanan P_1 gücü tablolardaki $P_{1 \text{ max}}$ değerini aşmamalıdır.

$$P_1 \leq P_{1 \text{ max}}$$

W ve IEC tipi redüktörler için performans tablosunda herbir çıkış devri n_2 , maksimum çıkış momenti M_{amax} , maksimum motor gücü $P_{1 \text{ max}}$ listelenmiştir.

Hareketli tarafa fren bağlandığında, (frenli motorlar gibi) fren momenti de bir dişli ünitesini seçmede göz önüne alınmalıdır. Gezinti hareketleri, çember dişliler, döner tablolar, kapı hareketleri, karıştırıcılar ve yüzey havalandırıcı ile ilgili uygulamalarda sıkça karşılaşılan yüksek dış kütle atalet momentli ($m_{af} > 2$) kullanımlarda frenleme momentinin, seçilen anma momentinin 1,2 katını aşmamasını öneririz. Daha yüksek frenleme torkları kullanılacaksa, bu durum dişli ünitesini seçerken göz önünde bulundurulmalıdır. Lütfen PGR'e danışınız.

Radyal ve Eksenel Kuvvetler

Motorlu seçim sayfalarındaki tablolarda, çıkış mili üzerine izin verilen radyal kuvvetler F_R ve eksenel kuvvetler F_A listelenmiştir. Tercihen güçlendirilmiş çıkış mili yatakları bir çok dişli ünitesi tipi için geçerlidir. Güçlendirilmiş yataklardaki radyal ve eksenel kuvvetler tablolarda F_{RGR} ve F_{AGR} olarak belirtilmiştir. Listelenen radyal ve eksenel kuvvetler, mil çıkışlı ayak ve flanş bağlantılı dişli üniteleri için uygulanır. Radyal ve eksenel kuvvetler, bu kuvvetlerden biri 0 (sıfır)'a eşit iken hesaplanmıştır.

Ayrıca, radyal ve eksenel kuvvetlere ait bir servis faktörü $f_B = 1$ çıkış gücü ve devir açıklamalı genel tablolarda verilen kuvvetlerin temeline dayanır. Darbeli tipli kuvvetlerin olduğu ve aşırı çalışmalı (> 8 saat/gün) uygulamalarda uygun servis faktörü $f_B > 1$ radyal ve eksenel kuvvetler için de gözönünde bulundurulmalıdır. İzin verilen kuvvetler F_A ve F_R belirli oranda azaltılır.

EN

EXPLANATORY NOTES

$$M_2 \text{ [Nm]}, n_2 \text{ [min}^{-1} \text{]}$$

If selection of gear unit is correctly done, service factor which is taken from selection of gear motors table, must be greater than minimum service factor $f_{B \text{ min}}$ which is taken from diagram-1 (see page 4) according to types of load.

Efficiency is approximately 98 % at helical, helical bevel parallel shaft gear units. For that reason efficiency could be taken $\eta = 1$ it shows that efficiency does not affect the calculation.

With W cylinder (free drive shafts); the installed drive output P_1 may, at the must be;

Value which calculated from formula P_1 , must be less than $P_{1 \text{ max}}$ which is taken from the selection of W cylinder tables.

$P_{1 \text{ max}}$ is shown at performance table for W cylinder (with free input shaft) and IEC adapter.

In selecting gear units brake can be optionally equipped which it is attached to the shaft or solid. It must be considered because of break torque. Application which have high external mass moment of inertia such as $m_{af} > 2$. We suggest break torque does not overrun 1,2 times motor torque.

Axial and Radial Forces

Permissible forces on the output shaft are given at the selection of gear motor. F_R represents radial load and F_A represents axial load. F_{RGR} and F_{AGR} represents permissible load with reinforced bearings. These values are calculated when one of them is equal to zero.

In selecting gear motor tables service factor is given with permissible axial and radial load but it must be considered when operating times is greater than 8 hours and service factor must be greater than 1 for that reason permissible radial and axial loads are reduced.

TR

TEKNİK BİLGİLER

Listelenen radyal kuvvetler, milin ucunun orta kısmında etki eden bir kuvvete karşılık gelir. İzin verilen kuvvetleri saptarken, uygulanan kuvvetin hiç istenmeyen yönü ve dönme yönü varsayıldı. Tam bir hesaplama için, daha yüksek radyal ve eksenel kuvvetler muhtemeldir. Bu yüzden lütfen bize istenen servis süresinin yanısıra gerçek güç ve dönme yönünün detaylarını da belirtiniz.

Transfer elemanları, çıkış miline eklenirse, ilgili faktör f_z radyal kuvveti saptamada göz önüne alınmalıdır.

f_z için Tablo

Transfer Elemanları	Faktör f_z	Açıklama
Dişliler	1.1	$z \leq 17$ diş
Zincir Dişliler	1.4	$z \leq 13$ diş
Zincir Dişliler	1.2	$z \leq 20$ diş
Dar V-Kayış Makaralar	1.7	ön gerilim kuvveti
Düz kayış Makaralar	2.5	

Mil üzerinde ortaya çıkan radyal kuvvet, aşağıdaki formül kullanılarak hesaplanmıştır.

$$F_{Rvorth} = \frac{2 \cdot M_a}{d_o} \cdot f_z \leq F_R$$

M_a : Dişli ünitesi çıkış momenti [kN]
 f_z : Tablodan alınan katsayı
 d_o : Etkili daire çapı [mm]
 F_R : Devir ve çıkış gücü tablolarından alınan müsaade edilebilir radyal kuvvet [kN]
 F_{Rvorth} : Mil üzerindeki radyal kuvvet [kN]

Kuvvet mil ortasına uygulanmazsa, herhangi bir 'X' noktasında izin verilen radyal kuvvet **formül I ve II** kullanılarak hesaplanır.

Formül / Formula - I

$$F_{RXL} = F_R \cdot \frac{z}{y + x}$$

Formül / Formula - II

$$F_{RXW} = \frac{c}{(f + x) \cdot 1000}$$

X mil faturasından kuvvet uygulama noktasına olan uzaklık [mm]
X noktası - mil kararlılığı
 F_{RXW} izin verilen radyal yük [kN]
 F_R hız ve çıkış tabloları ve milin ortasına uygulanan kuvvetten alınan radyal kuvvet [kN]
X Noktası - yatak servis ömrü
 F_{RXL} izin verilen radyal yük [kN]

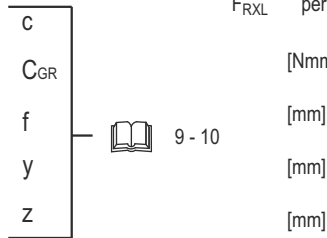

Belirtilmedi ki, hesaplamalarda **formül I** yatak servis ömrünü, **formül II** ise mil kararlılığını hesaplamada kullanılır. Hesaplamalar sonucunda küçük değer dikkate alınmalıdır.

EN

EXPLANATORY NOTES

Axial and radial forces are calculated where force acting on the middle of the shaft end see page 39. Direction of rotation plays an important role in calculation. For that reason these forces are calculated and the value of the result is found from forces to the shaft worse. Hence, please explain details in your orders.

For belt-pulley operations or any other motion transfer applications f_z factor must be considered while calculating radial and axial load.

f_z values are shown at table.

Transfer Elements	Factor f_z	Notice
Gears	1.1	$z \leq 17$ teeth
Chain Sprockets	1.4	$z \leq 13$ teeth
Chain Sprockets	1.2	$z \leq 20$ teeth
Narrow V-belt pulleys	1.7	by
Flat belt pulleys	2.5	Pre-Tensioning

Radial load is determined with following formula;

M_a : Output torque of gear unit [kN]
 f_z : Factor which is taken from table
 d_o : Effective circular diameter [mm]
 F_R : Permitted radial force which is taken from the speed and output moment tables. [kN]
 F_{Rvorth} : Radial force on the gear unit shaft [kN]

The formula which is mentioned above is used when force is not acting on the middle of shaft. In other situations the following formula is applied

X distance from the shaft collar to the point of force application [mm]
point X - shaft stability
 F_{RXW} permitted overhung force [kN]
 F_R overhung force from the speed and output tables, force applied at the middle of the shaft [kN]
point X - bearing service life
 F_{RXL} permitted overhung load [kN]

[Nmm]
[mm]
[mm]
[mm]

Notify that, **formula I** and **formula II** are applied for calculating radial load where **formula I** is used for service life and **formula II** is used for shaft stability. After the calculations were done some points should be taken into consideration.

TR

RADYAL YÜK HESABI

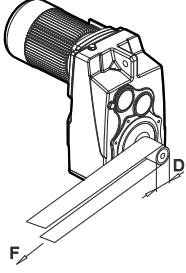

RADYAL YÜKLERİN HESABI

Radyal yük F_R (N)' nun hesaplanmasında gerekli tahrik momenti M_2 (Nm), kasnak veya dişli çapı D (mm) olmak üzere aşağıdaki formüller kullanılır.

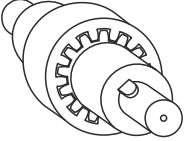

1 - Elastik Kaplin

Çalışma sırasında oluşan sarpmalar kaplinin güvenlik sınırları içerisinde ise kuvvetler ihmal edilebilir.

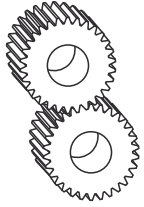

2 - Düz Dişli (20° kavrama açılı)

$$F_R = \frac{2100 \times M_2}{D}$$

3 - Küçük Hızlarda Zincir Dişli ($Z < 17$)

$$F_R = \frac{2100 \times M_2}{D}$$

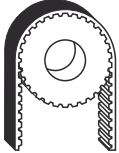

4 - Triger Kayış

$$F_R = \frac{2500 \times M_2}{D}$$



5 - V Kayış

$$F_R = \frac{5000 \times M_2}{D}$$



6 - Gerdirme Makaralı Kayış

$$F_R = \frac{5000 \times M_2}{D}$$

EN

CALCULATION OF RADIAL LOADS

CALCULATION OF OVERHUNG LOADS

Radial load F_R (N) is calculated with the following formulas where required moment M_a (Nm) and hoop or gear diameter D (mm) is used

1 - Elastik Coupling

If elastic coupling is working in its reliable working area, the overhung loads can be neglected.

2 - For Spur Gear (Pressure angle 20°)

3 - For Chain Drive With Low Speed ($Z < 17$)

4 - For Triger Belt

5 - For V Belt

6 - Flat Belt With Spanning Puley

TR

RADYAL YÜK HESABI

EN

CALCULATION OF RADIAL LOADS

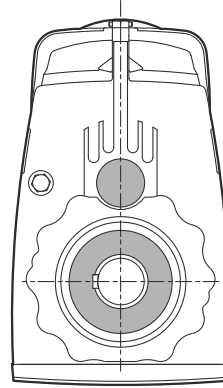
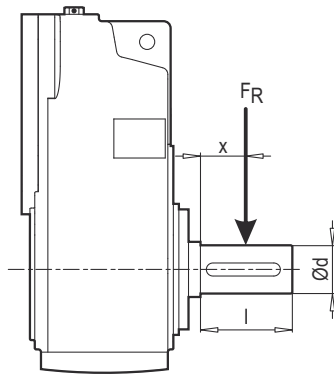

ÇIKIŞ MİLİNDEKİ RADYAL VE EKSENEL YÜK HESAPLAMALARI İÇİN DEĞERLER
VALUE TABLE FOR RADIAL AND AXIAL LOADS AT OUTPUT SHAFT

Redüktör Tipi Gearbox Type	y (mm)	z (mm)	c Normal Normal (Nmm)	c Güçlendirilmiş Reinforced (Nmm)	f (mm)	Ød (mm)	l (mm)
PM A02	80.0	104.5	0.13 X 10 ⁶	0.18 X 10 ⁶	0	25	50
PM B02	112.0	138.0	0.12 X 10 ⁶	0.17 X 10 ⁶	0	25	50
PM C13	145.0	176.0	0.16 X 10 ⁶	0.26 X 10 ⁶	0	30	60
PM 12 - PM 13	95.1	125.1	0.18 X 10 ⁶	0.27 X 10 ⁶	0	30	60
PM 22 - PM 23	109.6	144.6	0.27 X 10 ⁶	0.44 X 10 ⁶	0	35	70
PM 32 - PM 33	135.6	180.6	0.61 X 10 ⁶	0.94 X 10 ⁶	0	45	90
PM 42 - PM 43	158.1	213.1	0.90 X 10 ⁶	1.48 X 10 ⁶	0	55	110
PM 52 - PM 53	179.6	244.6	1.63 X 10 ⁶	2.60 X 10 ⁶	0	65	130
PM 62 - PM 63	235.6	305.6	1.82 X 10 ⁶	3.42 X 10 ⁶	0	75	140
PM 72 - PM 73	253.0	338.0	3.81 X 10 ⁶	6.19 X 10 ⁶	0	90	170
PM 82 - PM 83	300.0	405.0	8.31 X 10 ⁶	12.79 X 10 ⁶	0	110	210
PM 92 - PM 93	353.6	478.6	16.32 X 10 ⁶	24.92 X 10 ⁶	0	140	250
PM 102 - PM 103	425.0	575.0	-	18.95 X 10 ⁶	0	160	300
PM 112 - PM 113	453.0	603.0	-	19.15 X 10 ⁶	0	180	300
PM 123	453.0	603.0	-	20.30 X 10 ⁶	0	180	300

- W ADAPTÖR
- W ADAPTER

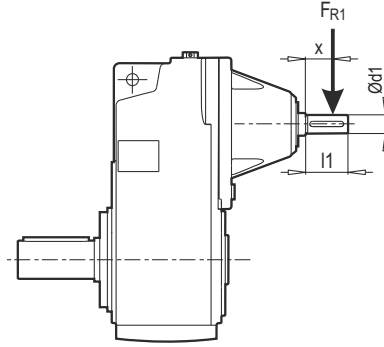
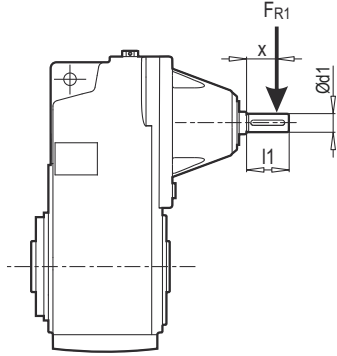

GİRİŞ ŞAFTINDAKİ RADYAL VE EKSENEL YÜK HESAPLAMALARI İÇİN DEĞERLER VALUE TABLE FOR RADIAL AND AXIAL LOADS AT INPUT SHAFT f=0					
Paralel Şaftlı Redüktör Parallel Shaft Gear Unit	y (mm)	z (mm)	c (mm)	Ød1 (mm)	l1 (mm)
PD/PM A02 PD/PM B02	58.5	78.5	0.027 x 10 ⁶	14	40
PD/PM C13	58.5	78.5	0.037 x 10 ⁶	16	40
PD/PM 12 PD/PM 13 PD/PM 23 PD/PM 33	70.0	90.0	3.64 x 10 ⁴	16	40
PD/PM 22 PD/PM 32 PD/PM 43 PD/PM 53	96.5	121.5	1.07 x 10 ⁵	24	50
PD/PM 42 PD/PM 52 PD/PM 63	110.5	150.5	4.70 x 10 ⁵	38	80
PD/PM 62 PD/PM 72 PD/PM 63* PD/PM 73 PD/PM 83 PD/PM 93	149.5	204.5	4.60 x 10 ⁵	42	110
PD/PM 82 PD/PM 92 PD/PM 83* PD/PM 93*	207.5	277.5	1.82 x 10 ⁶	65	140
PD/PM 102 PD/PM 103 PD/PM 112 PD/PM 113 PD/PM 123	413.0	482.0	-	70	140

* Simgesi güçlendirilmiş W adaptörleri için verilen değerleri gösterir.

* Sign shows that value which is given on table, for reinforced W adapter.

TR

RADYAL YÜK HESABI

EN

CALCULATION OF RADIAL LOADS

- W ADAPTÖR
- W ADAPTER

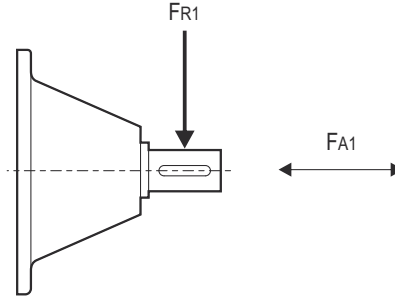

Tip Type	PD/PM A02 PD/PM B02		PD/PM C13		PD/PM 12 PD/PM 13 PD/PM 23 PD/PM 33		PD/PM 22 PD/PM 32 PD/PM 43 PD/PM 53		PD/PM 42 PD/PM 52 PD/PM 63		PD/PM 62 PD/PM 72 PD/PM 63* PD/PM 73 PD/PM 83 PD/PM 93		PD/PM 82 PD/PM 92 PD/PM 83* PD/PM 93*		PD/PM 102 PD/PM 103 PD/PM 112 PD/PM 113 PD/PM 123	
	[kN]	[kN]	[kN]	[kN]	[kN]	[kN]	[kN]	[kN]	[kN]	[kN]	[kN]	[kN]	[kN]	[kN]	[kN]	[kN]
P ₁ (kW)	F _{A1}	F _{R1}	F _{A1}	F _{R1}	F _{A1}	F _{R1}	F _{A1}	F _{R1}	F _{A1}	F _{R1}	F _{A1}	F _{R1}	F _{A1}	F _{R1}	F _{A1}	F _{R1}
0.12	1.2	0.55	1.2	0.85	1.2	0.85	2.9	2.1	-	-	-	-	-	-	-	-
0.18	1.1	0.54	1.1	0.82	1.1	0.82	2.9	2.1	-	-	-	-	-	-	-	-
0.25	1.0	0.53	1.0	0.78	1.0	0.78	2.8	2.1	-	-	-	-	-	-	-	-
0.37	0.89	0.50	0.89	0.75	0.89	0.75	2.6	2.1	4.1	2.1	-	-	-	-	-	-
0.55	0.77	0.47	0.77	0.72	0.77	0.72	2.5	2.0	3.9	2.8	-	-	-	-	-	-
0.75	0.58	0.44	0.58	0.70	0.58	0.70	2.3	1.9	3.8	2.4	6.1	4.4	-	-	-	-
1.10	0.35	0.37	0.35	0.61	0.35	0.61	2.1	1.8	3.5	2.7	5.9	4.3	-	-	-	-
1.50	0.29	0.30	0.29	0.43	0.29	0.43	2.0	1.8	3.3	2.6	5.8	4.2	-	-	-	-
2.20	-	-	0.20	0.42	0.20	0.42	1.7	1.7	2.7	2.4	5.5	4.1	-	-	-	-
3.00	-	-	0.15	0.23	0.15	0.23	1.5	1.6	2.5	2.3	5.2	3.9	4.3	11.0	-	-
4.00	-	-	-	-	-	-	0.98	1.1	2.3	2.1	4.9	3.7	4.2	10.9	-	-
5.50	-	-	-	-	-	-	0.65	1.0	1.6	1.8	4.4	3.4	4.1	10.8	-	-
7.50	-	-	-	-	-	-	0.27	1.0	1.4	1.3	4.3	3.4	3.8	10.4	-	-
9.20	-	-	-	-	-	-	-	-	1.0	0.98	3.9	3.1	3.6	10.1	-	-
11.0	-	-	-	-	-	-	-	-	0.59	0.47	3.3	2.7	3.4	9.9	13.4	17.3
15.0	-	-	-	-	-	-	-	-	-	-	3.3	2.7	3.1	9.5	13.7	17.1
18.5	-	-	-	-	-	-	-	-	-	-	2.7	2.3	3.0	9.3	13.4	16.9
22.0	-	-	-	-	-	-	-	-	-	-	2.2	1.8	2.9	9.3	13.1	11.7
30.0	-	-	-	-	-	-	-	-	-	-	1.1	1.2	2.3	8.4	12.5	16.1
37.0	-	-	-	-	-	-	-	-	-	-	0.74	0.87	2.0	8.1	12.0	15.7
45.0	-	-	-	-	-	-	-	-	-	-	-	-	2.2	8.3	11.7	15.2
55.0	-	-	-	-	-	-	-	-	-	-	-	-	1.5	7.4	11.0	14.5
75.0	-	-	-	-	-	-	-	-	-	-	-	-	0.78	4.6	9.6	13.2
90.0	-	-	-	-	-	-	-	-	-	-	-	-	0.24	5.2	8.5	12.1
110	-	-	-	-	-	-	-	-	-	-	-	-	-	-	7.2	10.7
132	-	-	-	-	-	-	-	-	-	-	-	-	-	-	6.8	9.0
160	-	-	-	-	-	-	-	-	-	-	-	-	-	-	5.0	6.9
200	-	-	-	-	-	-	-	-	-	-	-	-	-	-	2.6	3.6

F_{A1} → F_{R1} = 0
F_{R1} → F_{A1} = 0



7

* Simgesi güçlendirilmiş W adaptörleri için verilen değerleri gösterir.

* Sign shows that value which is given on table, for reinforced W adapter.

TR	KISALTMALAR	EN	ABBREVIATIONS
f_B	= Servis Faktörü (Mamax / Ma)	f_B	= Service factor (Mamax / Ma)
F_A	= Çıkış tarafındaki müsaade edilebilir aksenal yük [kN]	F_A	= Permissible axial load at the output side [kN]
F_R	= Çıkış tarafındaki, milin orta noktasına etkiyen müsaade edilebilir radyal yük [kN]	F_R	= Permissible overhung load at the output side, force acting at the shaft's midpoint [kN]
F_D	= Reaksiyon yükü [kN]	F_D	= Reaction [kN]
i_{toplam}	= Dişli ünitesindeki toplam tahvil oranı	i_{total}	= Gear units total ratio
i_{ges}	= Tahvil oranı	i_{ges}	= Reduction ratio
M_2	= Çıkış momenti [Nm]	M_2	= Output torque [Nm]
M_{amax}	= Müsaade edilebilir maksimum çıkış momenti [Nm]	M_{amax}	= Max. permissible output torque [Nm]
n_2	= Çıkış devri [d/dk]	n_2	= Output speed [min ⁻¹]
P_e	= Mamax referans alınarak hesaplanan güç [kW]	P_e	= Calculated power [kW] with reference to Mamax
P_n	= Motor güç oranı [kW]	P_n	= Motor power [kW]
η	= Verim [%]	η	= Efficiency [%]
kg	= Redüktörün ağırlığı	kg	= Weight of the geared motor

1) 4 ve 5 kademeli redüktörlerin 0,75 kW'a kadar olan 4 kutuplu motorlarında kayıp yaklaşık 40 W olarak hesaplanmıştır. Kayıp, motor hızına bağlı olarak o oranda değişir.

1) Gear units or gear motors which have 4 and 5 stage reduction 4 pole motor up to 0,75 kW losses are calculated nearly 40 W, losses are dependent motor speed.

TR

PD/PM TANITIMI

EN

DESCRIPTION OF PD/PM

POLAT PARALEL ŞAFTLI MOTORLU REDÜKTÖR (PD/PM)
POLAT PARALLEL SHAFT GEARED MOTOR (PD/PM)

Paralel şaftlı redüktör üniteleri için giriş ve çıkış şaftının paralel olma özelliği Polat Ayaklı (PA) ve Polat Flanşlı (PF) helisel serisine göre daha kompakt tasarım özelliği kazandırmaktadır. Delik milli redüktör üniteleri uygulanma alanındaki sisteme direk olarak montajlanabilir. Gövde büyüklüğü olarak PD/PM A02...52'ye kadar 2 kademeli redüktör ünitesi versiyonu olarak sunulmaktadır. PD/PM 12...52'ye kadar olan redüktör ünitelerine indirgeyici gövde montajlanarak 3 kademeli olarak (PD/PM 13 ...53) sunulmaktadır. Daha büyük gövde boyutları için PD/PM 62...112 ve PD/PM 63...123' e kadar 2 ve 3 kademeli olarak sağlanmaktadır. Büyük gövde redüktör tipleri (PD/PM 63...123' e kadar) olan dişli üniteleri küçük gövde redüktör tiplerinden (PD/PM 13...53) farklı olarak tüm iç yapısı aynı gövde içerisinde bulunmaktadır.

Delik milli ve mil çıkışlı olmak üzere paralel şaftlı redüktör ünitelerinin montajı için dört farklı tasarımı mevcuttur.

- 1) Ön yüzeyi B14 flanşı için işlenmiş flanş tasarımı
- 2) Ön yüzeyi B5 flanşı için işlenmiş flanş tasarımı
- 3) PD/PM A02... C13 ile PD/PM 92 ve üst gövde boyutları için ayak montajlı tasarım
- 4) Tork kolu tasarımı

15 farklı gövde seçeneğiyle hizmete sunulmuş olan Polat Delik Milli ve Polat Milli serisi redüktör üniteleri 0,12 kW' dan 200 kW' a kadar değişen güçleri ile maksimum 94000 Nm moment sağlayabilmektedir.

Paralel Şaftlı Redüktör

0,12 kW dan 200 kW' ya kadar
94000 Nm 'ye kadar çıkış momenti bulunur.

Polat parallel shaft gear unit series are provided in more compact design than Polat foot mounted and flange mounted helical gear series because the input and output shafts are parallel. Gear unit which have hollow shaft at output could be mounted directly to system at application areas. Case width, from PD/PM A02 to PD/PM 52 is presented as a two - stage version. Besides all these, third reduction gearbox is mounted to PD/PM 12 - 52 and these are presented as three - stage version which are designated from PD/PM 13 to PD/PM 53. Greater case sizes from PD/PM 62 to PD/PM 112 and from PD/PM 63 to PD/PM 123 are presented as a two and three - stage versions. These three stage cases are different from smaller case sizes which are designated from PD/PM 13 to PD/PM 53, because all of the components are built in the same case.

Four different designs are available for Polat parallel shaft gear unit series with hollow shaft or solid shaft. These are;

- 1) Flange mounted designs which are machined for B14 flange
- 2) Flange mounted designs which are machined for B5 flange
- 3) Foot mounted designs for PD/PM A02...C13 and PD/PM 92 and above gear units
- 4) Torque arm designs

Polat with hollow shaft or Polat with solid shaft gear unit series are provided maximum 94000 Nm moment according to output power range from 0,12 kW to 200 kW and these are available at 15 different sizes.

Parallel Shaft Gear Unit

Approx. 94000 Nm output moment
altering power from 0,12 kW to 200 kW.

MAX. MÜSAADE EDİLEBİLİR ÇIKIŞ MOMENTİ $M_{a \max}$.

MAX. PERMISSIBLE OUTPUT TORQUES $M_{a \max}$.

171 - 193

İki ve Üç kademeli paralel şaftlı redüktör

Parallel shaft gear units, double and triple stage reduction

Tip/Type	$M_{a \max}$ (Nm)	Tip/Type	$M_{a \max}$ (Nm)	Tip/Type	$M_{a \max}$ (Nm)	Tip/Type	$M_{a \max}$ (Nm)	Tip/Type	$M_{a \max}$ (Nm)
PD/PM A02	120	PD/PM 12	300	PD/PM 13	270	PD/PM 62	4540	PD/PM 92	17930
PD/PM B02	170	PD/PM 22	560	PD/PM 23	560	PD/PM 72	6470	PD/PM 102	32000
PD/PM C13	370	PD/PM 32	1020	PD/PM 33	1040	PD/PM 82	10620	PD/PM 112	42000
		PD/PM 42	2000	PD/PM 43	2080	PD/PM 63	6000	PD/PM 93	25400
		PD/PM 52	3240	PD/PM 53	3200	PD/PM 73	8300	PD/PM 103	37200
						PD/PM 83	13200	PD/PM 113	69000
								PD/PM 123	90000

W ve IEC Adaptör

W kovanlı redüktörlerin max. tahrik gücü geçerli olan çıkış devri ve tahvil oranına göre tablolarda verilmiştir. (Bknz 171-193) IEC adaptörlü dişli ünitelerinde, her gövde büyüklüğünün standart gücü DIN EN 50347' ye göre verilir. P1 değeri W ve IEC seçim sayfalarında listelenmiştir. Bu listedeki değerlerden fazla bir güç istenirse özel hesaplamalar gerekmektedir. Lütfen danışınız.

W kovanlı redüktörlerin giriş mili rulmanları düzenli olarak yağlanmalıdır. 2 kademeli redüktörlerden PD/PM 62 ve üst gövdeler, 3 kademeli redüktörlerden PD/PM 73 gövdelerine bağlanmaktadır. Bu otomatik yağlayıcı rulmanlara kalıcı bir yağlama sağlar. Redüktörü çalıştırmadan önce devreye sokulmalıdır. Günlük ortalama 8 saat çalışıyorsa yılda 1 kez, bunun dışındaki çalışma saatlerinde 6 ayda bir değiştirilmelidir. Otomatik yağlayıcı içindeki gres dış ortam sıcaklığı 0° C - 40° C arasındaki çalışmalara uygundur. Çok uzun süreli çalışmalarda ve belirtilen dış ortam sıcaklığı değişimlerinde daha özel yağlayıcı kullanılmalıdır. Lütfen danışınız.

Otomatik yağlayıcı üniteleri IEC 160 motor büyüklüğünden başlayarak en düşük 2 kademeli redüktörlerden PD/PM 62, 3 kademeli redüktörlerden de PD/PM 73 gövdelerine bağlanmaktadır. Bu otomatik yağlayıcı rulmanlara kalıcı bir yağlama sağlar. Redüktörü çalıştırmadan önce devreye sokulmalıdır. Günlük ortalama 8 saat çalışıyorsa yılda 1 kez, bunun dışındaki çalışma saatlerinde 6 ayda bir değiştirilmelidir. Otomatik yağlayıcı içindeki gres dış ortam sıcaklığı 0° C - 40° C arasındaki çalışmalara uygundur. Çok uzun süreli çalışmalarda ve belirtilen dış ortam sıcaklığı değişimlerinde daha özel yağlayıcı kullanılmalıdır. Lütfen danışınız.

Otomatik yağlayıcı IEC'ler belirtilen çalışma şartları içerisinde **dikey montaj pozisyonunda (M2 ve M4) önerilmez**. Bu gibi durumlarda direkt motor montajı önerilir. Eğer motor boyutu 160 ve daha büyük IEC'ler dikey montaj pozisyonunda kullanılacaksa, kullanım şartları göz önünde bulundurularak tarafımızdan kontrol edilmeli ve onaylanmalıdır. Lütfen buna dikkat ediniz. Dikey montaj pozisyonu çalışmalarında (M2) sızdırmazlık elemanlarının ömrü azalabilmektedir. Bu gibi durumlarda daha kısa aralıklarla bakım yapılmalıdır. 2 kademeli redüktörlerden PD/PM 52'ye kadar ve 3 kademeli redüktörlerden PD/PM 63'e kadar olan IEC adaptörlü dişli üniteleri çalışma ömürleri süresince sızdırmazlığa sahip yağlanmış rulman içerir. Bunlar için bakım süreleri kullanım kılavuzunda önerilen bakım süreleri geçerlidir.

Motor boyutu 63'ten 180'e kadar olan IEC adaptörün kaplini arızaya karşı emniyetli değildir. Fakat otomatik yağlayıcı kullanılan IEC 160-180 ve daha büyük boyutlu adaptörlerdeki kaplinler arızaya karşı emniyetlidir. Kaldırma, asansör ve bu gibi insan yaralanmalarına neden olabilecek çalışmalar için özel hesaplamalar gerekmektedir. Lütfen PGR' ye danışınız. Direkt motor montajlı redüktörle karşılaştırmak gerekirse IEC ilave mil kaplinine ve extra rulman yataklanmasına sahiptir. Direkt motor montajına göre IEC bağlantılı redüktörlerde güç kayıpları daha fazladır. PGR olarak biz direkt motor montajını öneririz. Bu size sadece teknik avantaj değil finansal olarak da avantaj sağlar.

W and IEC Adapter for Gear Units

The way of selecting W cylinder (with free input shaft) and IEC adapter are listed on page 171-193. Maximum power are given according to gear reduction ratio and output speed. Gear units with IEC adapter standard power are specified according to DIN EN 50347. For other power values which are not shown on table, special calculations are required for operating safety limits. For these cases, please contact PGR.

Polat gear unit series such as PD/PM 62 and greater cases which are 2 stage reducers PD/PM 73 and greater cases which are 3 stage reducers with W adapter (with free input shaft) input solid shaft bearings must be lubricated orderly. Automatic lubricator could be used for increasing service life of bearings. This unit includes approximately 20-25 g grease and it supplies fresh grease at every 4000 running hours. PGR recommends using Petamo GHY 133 N type of lubricate. At the same time, fan option is available for cool gear unit for safe operation. For this option contact PGR

Automatic lubricator design is used from IEC 160 motor size and greater motor size to small gear units which are for 2 stage reducers PD/PM 62 and for 3 stage reducers PKD 6390. This unit provides permanent lubrication to bearings. Automatic lubricator must be changed once a year in case gear unit runs 8 hours or less at daily operation for other running hours it must be changed every 6 months. Automatic lubricator must be actuated before starting the reducers. Grease is acceptable between 0 °C - 40 °C operation conditions. At long - term running and except from specified ambient temperature special lubricate must be used. Please, consult us.

Under determined operating conditions, **IEC with automatic lubricator is not suggested for vertical mounting positions (M2 and M4 mounting positions)**. For these cases direct motor mounting should be applied. If IEC 160 and greater size will be used at vertical mounting positions, it must be controlled by PGR for suitable and safe operations with considering actual operating conditions. For mounting position M2 (vertical alignment) life cycle of seals are affected badly for that reason maintenance of these reducer must be at shorter times from which maintenance time is determined at manual. 2 stage reducers up to PD/PM 52 and 3 stage reducer up to PD/PM 63 gear units are included seals for bearings as long as their service life. For these gear units maintenance time is valid as the time specified at manual.

Coupling is used for installing motor to IEC adapter. From IEC 63 to IEC 180, coupling is not safe for important application since human injuries could occur. But IEC 160 - IEC 180 with automatic lubricator and greater size of IEC adapter is safe for application but on the other hand for operations where accident could be caused personnel damage special calculation is required, please consult us. Direct motor mounting has a lot of advantage according to mounting of IEC adapter. At gear units with IEC adapter has additional solid shaft coupling and bearing seats for that reason power losses are greater than direct motor mounting. Last but not least direct motor coupling not only has technical advantages but also financial advantages.

TR

KULLANIM ALANLARI

EN

APPLICATION AREAS

UYGULAMALAR	APPLICATIONS
KARIŞTIRICILAR	AGITATORS (MIXERS)
<ul style="list-style-type: none"> * Saf Sıvılar * Sıvılar ve Katılar * Değişken Yoğunluklu Sıvılar 	<ul style="list-style-type: none"> * Pure Liquids * Liquids and Solids * Liquids - Variable Density
HAVALANDIRMA TERTİBATLARI	BLOWERS
<ul style="list-style-type: none"> * Santrifüj * Lob * Pervane 	<ul style="list-style-type: none"> * Centrifugal * Lobe * Vane
MAYALAMA VE DAMITMA	BREWING AND DISTILLING
<ul style="list-style-type: none"> * Şişeleme Mekanizması * Mayalama Kazanları - Kesintisiz İş * Fırınlr, Ocaklar - Kesintisiz İş * Ezme, Karışım Kazanları - Kesintisiz İş * Ölçü Haznesi - Sık Sık Başlama 	<ul style="list-style-type: none"> * Bottling Machinery * Brew Kettles - Continuous Duty * Cookers - Continuous Duty * Mash Tubs - Continuous Duty * Scale Hopper - Frequent Starts
TOPRAK İŞLEME MAKİNELERİ	CLAY WORKING MACHINERY
<ul style="list-style-type: none"> * Tuğla Presi * Briket Makinesi * Çamur Karma Makinesi 	<ul style="list-style-type: none"> * Brick Press * Briquette Machine * Pug Mill
KOMPRESÖRLER	COMPRESSORS
<ul style="list-style-type: none"> * Santrifüj * Lob * Çok Pistonlu * Tek Pistonlu 	<ul style="list-style-type: none"> * Centrifugal * Lobe * Reciprocating, Multi-Cylinder * Reciprocating, Single-Cylinder
KONVEYÖRLER - GENEL MAKSATLI	CONVEYORS - GENERAL PURPOSE
<ul style="list-style-type: none"> * Üniform Yüklü * Üniform Yüklü Olmayan * Pistonlu veya Karıştırıcı 	<ul style="list-style-type: none"> * Uniformly Loaded or Fed * Not Uniformly fed * Reciprocating Or Shaker
VİNÇLER	CRANES
<ul style="list-style-type: none"> * Kuru Havuz Ana Kaldırma vinci Yardımcı Vinç Direkli Vinç Döndürme İşi Çekme İşi * Endüstriyel İşi Ana Kaldırma Vinci 	<ul style="list-style-type: none"> * Dry Dock Main Hoist Auxiliary Hoist Boom Hoist Slewing Drive Traction Drive * Industrial Duty Main Hoist
ASANSÖRLER	ELEVATORS
<ul style="list-style-type: none"> * Kova * Santrifüj Boşaltma * Yürüyen Merdiven * Taşıma, Nakliye * Yerçekimi Boşaltım 	<ul style="list-style-type: none"> * Bucket * Centrifugal Discharge * Escalators * Freight * Gravity Discharge
KIRMA MAKİNELERİ	CRUSHER
<ul style="list-style-type: none"> * Taş ya da Maden 	<ul style="list-style-type: none"> * Stone or Ore

UYGULAMALAR	APPLICATIONS
TARAMA MAKİNELERİ	DREDGES
<ul style="list-style-type: none"> * Kablo Bobinleri * Konveyörler * Pompalar * İstifleme Makineleri * Vinçler 	<ul style="list-style-type: none"> * Cable Reels * Conveyors * Pumps * Stackers * Winches
EKSTRUDERLER	EXTRUDERS
<ul style="list-style-type: none"> * Genel * Plastikler <ul style="list-style-type: none"> Değişken Hızlı Tahrik Sabit Hızlı Tahrik *Kauçuk, Lastik <ul style="list-style-type: none"> Kesintisiz Vida İşlemleri Kesintili Vida İşlemleri 	<ul style="list-style-type: none"> * General * Plastics <ul style="list-style-type: none"> Variable Speed Drive Fixed Speed Drive *Rubber <ul style="list-style-type: none"> Continuous Screw Operation Intermittent Screw Operation
FANLAR	FANS
<ul style="list-style-type: none"> * Santrifüj * Yüksek Emişli * İndüklenmiş Çekiş * Endüstriyel ve Maden Ocağı 	<ul style="list-style-type: none"> * Centrifugal * Forced Draft * Induced Draft * Industrial and Mine
BESLEME ÜNİTELERİ	FEEDERS
<ul style="list-style-type: none"> * Palet * Bant * Disk * Pistonlu * Vida 	<ul style="list-style-type: none"> * Apron * Belt * Disc * Reciprocating * Screw
GIDA ENDÜSTRİSİ	FOOD INDUSTRY
<ul style="list-style-type: none"> * Hububat Fırını * Hamur Karıştırıcı * Kıyma Makinesi * Dilimleyici 	<ul style="list-style-type: none"> * Cereal Cooker * Dough Mixer * Meat Grinder * Slicer
METAL İŞLEMELERİ	METAL MILLS
<ul style="list-style-type: none"> * Çekme Makinesi Taşıma ve Ana Tahrik * Hammadde İtici * Makaslar * Tel Çekme * Tel Sargı Makinesi * Salgı Tezgahı <ul style="list-style-type: none"> Geri Dönmesiz Tek Tahrik Grup Tahriki 	<ul style="list-style-type: none"> * Draw Bench Carriage and Main Drive * Slab Pushers * Shears * Wire Drawing * Wire Winding Machine * Runout Table <ul style="list-style-type: none"> Non-Reversing Individual Drives Group Drives
DÖNER İŞLEMELER	MILLS (ROTARY TYPE)
<ul style="list-style-type: none"> * Küresel ve Çubuk <ul style="list-style-type: none"> Düz Halka Dişli Helisel Halka Dişli Doğrudan Bağlı * Çimento Fırını * Kurutucular ve Soğutucular 	<ul style="list-style-type: none"> * Ball and Rod <ul style="list-style-type: none"> Spur Ring Gear Helical Ring Gear Direct Connected * Cement Kilns * Dryers and Coolers

TR

KULLANIM ALANLARI

EN

APPLICATION AREAS

UYGULAMALAR

KERESTE ENDÜSTRİSİ

- * Kabuk Soyucular
 - Besleme Tamburu
 - Ana Tahrık
- * Konveyörler
 - Brülör
 - Ana Yük veya Ağır Yük
 - Ana Kütük
 - Hızır ve Taşıma Bandı
 - Kalın Dilim
 - Taşıma
- * Kesme Testereleri
 - Zincir
 - Sürükleme
- * İndirme Boşaltma Tamburları
- * Uzun Deste
- * Tomruk Çekme-Eğme
- * Kütük Döndürme Aygıtları
- * Sıralama Tablası
- * Taşıma
 - Zincir
 - Kreynyolu
- * Tabla Tahriki

KAĞIT İŞLEMELERİ

- * Karıştırıcı
- * Saf çözeltiler için Karıştırıcı
- * Kabuk Soyma Tromelleri
- * Mekanik Kabuk Soyucu
- * Dövücü - Öğütücü
- * Düzleştirme Makinesi
- * Kalenderleme
- * Yüzey Pürüzlendirici
- * Çentik Besleyici
- * Kaplama Merdanesi
- * Konveyörler
 - Çentik, Kabuk, Kimyasal
 - Kalın Dilimler İçeren Kütükler
- * Kesici
- * Silindirik Kalıpları
- * Kurutucu
 - Kağıt Makinesi
 - Konveyör Tip
- * Kabartmalı Basıcı
- * Ekstrüder
- * Kağıt Merdaneleri
- * Presler
- * Küspe Makinesi
- * Pompalar

FİLTRELER

- * Havalı Yıkama
- * Döner - Taş veya Çakıl
- * Hareketli Su Girişi

APPLICATIONS

LUMBER INDUSTRY

- * Barkers
 - Spindle Feed
 - Main Drive
- * Conveyors
 - Burner
 - Main or Heavy Duty
 - Main Log
 - Re-saw, Merry-Go-Round
 - Slab
 - Transfer
- * Cut-Off Saws
 - Chain
 - Drag
- * Debarking Drums
- * Long Deck
- * Log Hauls - Incline
- * Log Turning Devices
- * Sorting Table
- * Transfers
 - Chain
 - Causeway
- * Tray Drives

PAPER MILLS

- * Agitator (Mixer)
- * Agitator for Pure Liquors
- * Barking Drums
- * Mechanical Barkers
- * Beater
- * Breaker Stack
- * Calender
- * Chipper
- * Chip Feeder
- * Coating Rolls
- * Conveyors
 - Chip, Bark, Chemical
 - Log (including Slab)
- * Cutter
- * Cylinder Molds
- * Dryer
 - Paper Machine
 - Conveyor Type
- * Embosser
- * Extruder
- * Paper Rolls
- * Presses
- * Pulper
- * Pumps

SCREENS

- * Air Washing
- * Rotary - Stone or Gravel
- * Traveling Water Intake

TR

KULLANIM ALANLARI

EN

APPLICATION AREAS

UYGULAMALAR

PLASTİK ENDÜSTRİSİ
İLK İŞLEMLER

- * Yoğun İç Karıştırıcılar
Harmanlayıcı
Kesintisiz Karıştırıcı

PLASTİK ENDÜSTRİSİ
İKİNCİL İŞLEMLER

- * Hacim Kalıpları
- * Kaplama
- * Tabaka
- * Boru
- * Ön Plastikleştirme
- * Rot
- * Saç, Plaka
- * Borular

POMPALAR

- * Santrifüj
- * Oranlama
- * Pistonlu
Tek Tesirli - 3 veya daha fazla Silindir
Çift Tesirli - 2 veya daha fazla Silindir
- * Döner
Şanzuman Tipi
Lob
Pervane

KAUÇUK - LASTİK ENDÜSTRİSİ

- * Yoğun İç Karıştırıcılar
Harmanlayıcılar
Kesintisiz Karıştırıcılar
- * Karıştırma İşlemi
2 Yumuşak Merdane
1 veya 2 Oluklu Merdane
- * Toplu İşleme - 2 Yumuşak Silindir
- * Kırıcı ve Isıtıcı - 2 Merdane, 1 Oluklu Merdane
- * Kırıcı - 2 Oluklu Merdane
- * Tutma, Besleme, Karıştırma İşlemi - 2 Merdane
- * Artırcı - 2 Merdane
- * Kalenderler

ATIK SU BOŞALTIM EKİPMANLARI

- * Çubuklu Elek
- * Kimyasal Besleme Üniteleri
- * Su Boşaltma Eleği
- * Köpük Kesici
- * Yavaş veya Hızlı Karıştırıcılar
- * Tortu Toplayıcı
- * Koyulaştırıcı
- * Vakumlu Filtre

KOMPAKTÖRLERÇEKİRMELER - YAVAŞ VE KUVVETLİ

APPLICATIONS

PLASTIC INDUSTRY
PRIMARY PROCESSING

- * Intensive Internal Mixers
Batch Mixers
Continuous Mixers

PLASTIC INDUSTRY
SECONDARY PROCESSING

- * Blow Molders
- * Coating
- * Film
- * Pipe
- * Pre-Plasticizers
- * Rods
- * Sheet
- * Tubing

PUMPS

- * Centrifugal
- * Proportioning
- * Reciprocating
Single Acting - 3 or more cylinders
Double Acting - 2 or more cylinders
- * Rotary
Gear Type
Lobe
Vane

RUBBER INDUSTRY

- * Intensive Internal Mixers
Batch Mixers
Continuous Mixers
- * Mixing Mill
2 Smooth Rolls
1 or 2 corrugated Rolls
- * Batch Drop Mill - 2 Smooth Rolls
- * Cracker Warmer-2 Rolls, 1 Corr. Roll
- * Cracker - 2 Corrugated Rolls
- * Holding, Feed and Blend Mill - 2 Rolls
- * Refiner - 2 Rolls
- * Calenders

SEWAGE DISPOSAL EQUIPMENT

- * Bar Screens
- * Chemical Feeders
- * Dewatering Screen
- * Scum Breaker
- * Slow or Rapid Mixers
- * Sludge Collector
- * Thickener
- * Vacuum Filter

COMPACTORSPULLERS - BARGE HAUL

TR

KULLANIM ALANLARI

EN

APPLICATION AREAS

UYGULAMALAR

ŞEKER ENDÜSTRİSİ

- * Pancar Dilimleme Aleti
- * Kamış Bıçakları
- * Kırma Makineleri

TEKSTİL ENDÜSTRİSİ

- * Harman Ölçer
- * Kalenderler
- * Şablonlar
- * Kuru Konserveler
- * Boyama Makinesi
- * Dokuma Tezgahları
- * Çamaşır Sıkma Makinesi - Merdane
- * Kaplama
- * Doldurma Makinesi
- * Haşıl Makinesi
- * Halat Yıkama Makinesi
- * Eğirme Makinesi
- * Germe Kurutma Makineleri
- * Yıkama Makineleri
- * Masura Sarcısı

DAMPERLİ ARAÇLAR

ÇEKİCİ ARAÇLAR

ARITICILAR

KONSERVE DOLUM MAKİNELERİ

APPLICATIONS

SUGAR INDUSTRY

- * Beet Slicer
- * Cane Knives
- * Crushers

TEXTILE INDUSTRY

- * Batcher
- * Calenders
- * Cards
- * Dry Cans
- * Dyeing Machinery
- * Looms
- * Mangle
- * Napper
- * Pads
- * Siashers
- * Soapers
- * Spinners
- * Tenter Frames
- * Washers
- * Winders

CAR DUMPERS

CAR PULLERS

CLARIFIERS

CAN FILLING MACHINES

TR

KULLANILAN TERİMLER

EN

NOMENCLATURE

REDÜKTÖR TİPİ GEAR TYPE		REDÜKTÖR DİZAYNI GEAR DESIGN	
Delik Milli Seri Hollow Shaft Series	(PD Serisi) (PD Series)	PD... =	Delik milli Hollow shaft
PD A02 ... PD 112 =	İki kademeli, paralel şaftlı redüktör Double reduction, parallel shaft gear unit series	PM... =	Mil çıkışlı Solid shaft
PD C13 ... PD 123 =	Üç kademeli, paralel şaftlı redüktör Triple reduction, parallel shaft gear unit series	PD... LT =	Delik milli, Lastik takozlu Hollow shaft, Rubber buffer for torque arm
PD 12/02 ... PD 52/12 =	Dört kademeli, paralel şaftlı redüktör Quadruple reduction, parallel shaft gear unit series	PM... LT =	Mil çıkışlı, Lastik takozlu Solid shaft, Rubber buffer for torque arm
PD 63/22 ... PD 113/52 =	Beş kademeli, paralel şaftlı redüktör Quintuple reduction, parallel shaft gear unit series	PD... Ç =	Delik milli, Çektirmeli Hollow shaft with fixing element
Çıkış Milli Seri Solid Shaft Series	(PM Serisi) (PM Series)	PD... Ç/LT =	Delik milli, Çektirmeli, Lastik takozlu Hollow shaft with fixing element, Rubber buffer for torque arm
PM A02 ... PM 112 =	İki kademeli, paralel şaftlı redüktör Double reduction, parallel shaft gear unit series	PD... KS =	Delik milli, Konik sıkırtmalı Hollow shaft with shrink disc connector
PM C13 ... PM 123 =	Üç kademeli, paralel şaftlı redüktör Triple reduction, parallel shaft gear unit series	PD... KS/LT =	Delik milli, Konik sıkırtmalı, Lastik takozlu Hollow shaft with shrink disc connector, Rubber buffer for torque arm
PM 12/02 ... PM 52/12 =	Dört kademeli, paralel şaftlı redüktör Quadruple reduction, parallel shaft gear unit series	PD... B14 =	Delik milli, B14 flanşlı Hollow shaft, B14 flange
PM 63/22 ... PM 113/52 =	Beş kademeli, paralel şaftlı redüktör Quintuple reduction, parallel shaft gear unit series	PD... B5 =	Delik milli, B5 flanşlı Hollow shaft, B5 flange
		PM... B14 =	Mil çıkışlı, B14 flanşlı Solid shaft, B14 flange
		PM... B5 =	Mil çıkışlı, B5 flanşlı Solid shaft, B5 flange
		PD... Ç/B5 =	Delik milli, Çektirmeli, B5 flanşlı Hollow shaft with fixing element, B5 flange
		PD... Ç/B14 =	Delik milli, Çektirmeli, B14 flanşlı Hollow shaft with fixing element, B14 flange
		PD... KS/B14 =	Delik milli, Konik sıkırtmalı, B14 flanşlı Hollow shaft with shrink disc connector, B14 flange
		PD... KS/B5 =	Delik milli, Konik sıkırtmalı, B5 flanşlı Hollow shaft with shrink disc connector, B5 flange

TR

KULLANILAN TERİMLER

EN

NOMENCLATURE

Giriş Aksamları Input Options	Motor Motor	Kutup Numarası Number of Poles	Motor Seçenekleri Motor Options
<p>W = Motorsuz girişli redüktörler için aksam = With free input shaft</p> <p>IEC = DIN 42677' ye göre standart motorlar için aksamlar = For assembly with IEC standard motors acc. to DIN 42677</p> <p>T = Turbo kaplin = Turbo coupling</p>	<p>Üç fazlı motor Motor boyutu 63 - 315</p> <p>Three phase motor Motor size 63 - 315</p> <p>EExell = Patlamaya karşı güvenliği artırılmış üç fazlı motor = Explosion proof three phase motor increased safety</p>	<p>2 = 2 Kutuplu = 2 - Poles</p> <p>4 = 4 Kutuplu = 4 - Poles</p> <p>6 = 6 Kutuplu = 6 - Poles</p> <p>4 - 2 = 1:2 oranında hız değiştirici dahlander bağlantısı = Pole changing 1:2 Dahlander connection</p> <p>8 - 2 = 1:4 oranında hız değiştirici ayrılmış sarmal dizilişli = Pole changing 1:4 Separate windings</p> <p>Diğer kutup kombinasyonları talep karşısında karşılanacaktır Other pole combinations on request</p>	<p>BRE = Frenli = With brake</p> <p>EF = Tek fazlı, fanlı = Separate fan, single phase</p> <p>ZF = Çift fazlı, fanlı = Separate fan, double phase</p> <p>DF = Üç fazlı, fanlı = Separate fan, three phase</p> <p>IG = Enkoderli = With encoder</p> <p>KK/FK = Debriyajlı = With clutches</p> <p>SR = Toza karşı korumalı fren = Brake dust - proof</p> <p>TF = Termistörlü = Thermistor</p> <p>RG = Korozyon korumalı frenli = Brake corrosion - protected</p> <p>WU = Yumuşak kalkışlı rotor = Soft start rotor</p> <p>B = Geri dönmeye karşı kilitli = Backstop</p> <p>TW = Isıya duyarlı = Thermal trip</p> <p>HL = Manuel frenli motor = Brake motor with hand release</p>

TR

PD/PM MODÜLER SİSTEMİ

EN

MODULAR SYSTEM OF PD/PM

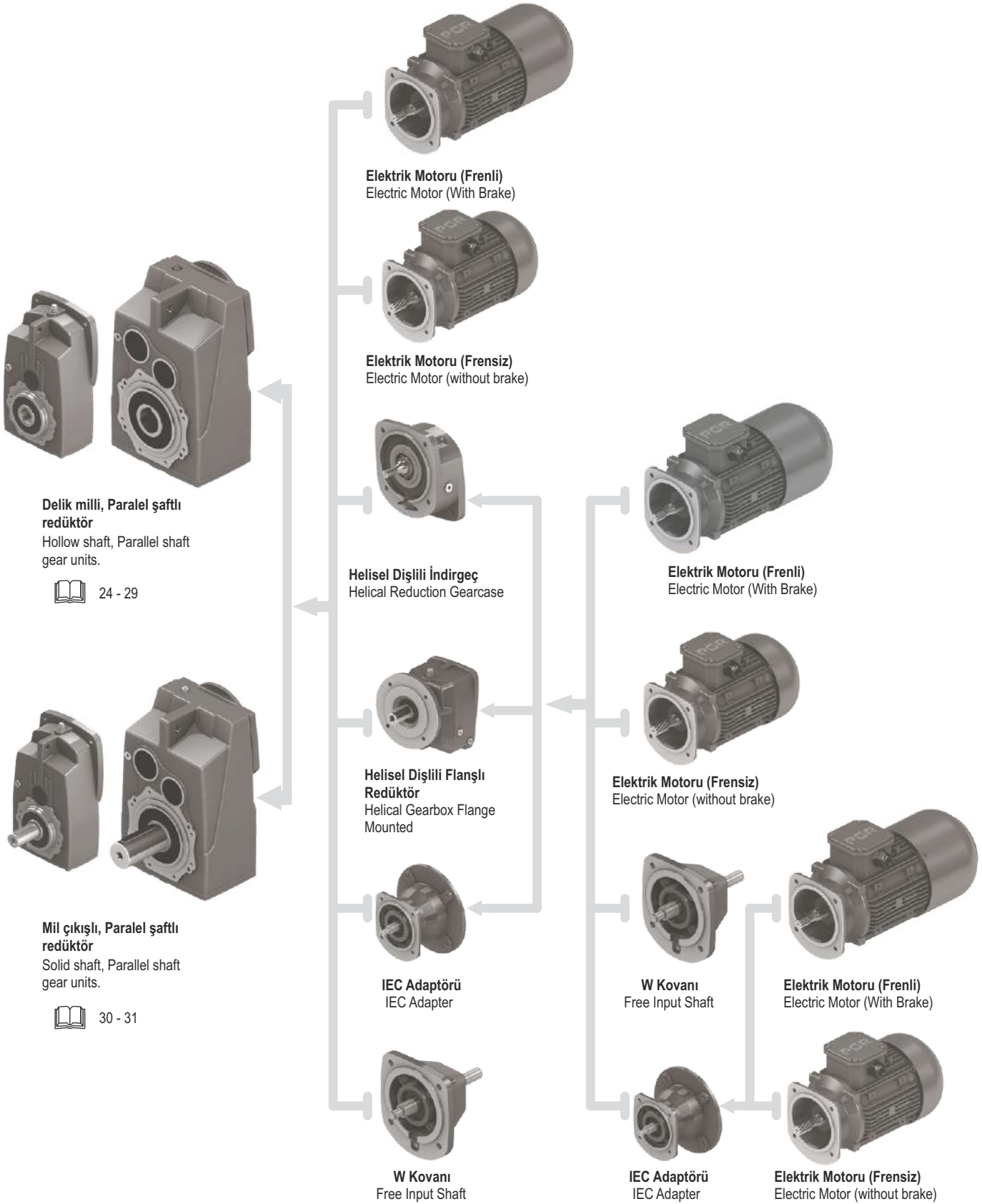

TR

MEVCUT DİZAYNLARA GENEL BAKIŞ

EN

OVERVIEW TO AVAILABLE DESIGNS

Kısaltmalar Abbrev.	Anlamı Meaning	Paralel Şaftlı Redüktör Parallel Shaft Gear Units
D	Delik milli Hollow shaft	✓
M	Mil çıkışlı Solid shaft	✓
B5	B5 Flanşı Flange B5	✓
B14	B14 Flanşı Flange B14	✓
Ç	Çektirme elemanı Fixing element	✓
LT	Lastik takoz Rubber buffer for torque arm	✓
KS	Konik sıkırma Shrink disc connector	✓
DIN 5480	Kayıcı delik milli DIN 5480 Splined hollow shaft, DIN 5480	✓ (2)
KK	Koruma kapağı Cover as a touch guard	✓
IEC	IEC Adaptörü Adapter for mounting standard motors to gear unit	✓
W	W Kovanı Free input shaft	✓
B	Kilit Integrated Backstop	✓
GR	Güçlendirilmiş rulman Reinforced bearing	✓
WB	W Kilidi Backstop in W adapter	✓
GKS	Güçlendirilmiş konik sıkırma Hollow shaft with reinforced shrink disc connector	✓
GB5	Güçlendirilmiş B5 Flanşı Agitator design	✓
PD A - B - C	Delik milli, ayak montajlı Hollow shaft, foot mounted	✓ (1)
PM A - B - C	Mil çıkışlı, ayak montajlı Solid shaft, foot mounted	✓ (1)
PD... B5	Delik milli, B5 Flanşı Hollow shaft, Flange B5	✓
PD... B14	Delik milli, B14 Flanşı Hollow shaft, Flange B14	✓
PM... B5	Mil çıkışlı, B5 Flanşı Solid shaft, Flange B5	✓
Ç-LT	Çektirme elemanı, Lastik takozlu Hollow shaft with fixing element, Rubber buffer for torque arm	✓
KS-LT	Konik sıkırmalı, Lastik takozlu Hollow shaft with shrink disc connector, Rubber buffer for torque arm	✓
Ç-B5	Çektirmeli, B5 Flanşı Hollow shaft with fixing element, Flange B5	✓
Ç-B14	Çektirmeli, B14 Flanşı Hollow shaft with fixing element, Flange B14	✓
KS-B5	Konik sıkırmalı, B5 Flanşı Hollow shaft with shrink disc connector, Flange B5	✓
KS-B14	Konik sıkırmalı, B14 Flanşı Hollow shaft with shrink disc connector, Flange B14	✓

✓ Mevcut tasarımlar onay işareti ile belirtilmiştir.

- 1-) PD/PM A02 - B02 - C13 redüktör tipleri ayak montajı opsiyonu içermektedir.
- 2-) DIN 5480 opsiyonu PD A02 - B02 - C13 ile PD 102 dahil ve üst gövdeler için mevcut değildir.

✓ Sign is presented which designs are existed for gear units.

- 1-) PD/PM A02 - B02 - C13 gear unit series include foot mounted option
- 2-) DIN 5480 option is not available for PD A02 - B02 - C13 and PD 102 inclusive and higher gear unit types.

1) PD 32... - 80M/4A

Delik milli, İki kademeli, Paralel şaftlı,
Motorlu redüktör

Hollow shaft, Double reduction, Parallel shaft
gear unit, With motor

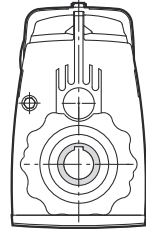
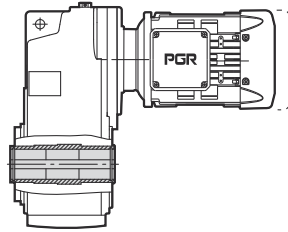

PD 32... - IEC 90

Delik milli, İki kademeli, Paralel şaftlı,
IEC adaptörlü redüktör

Hollow shaft, Double reduction, Parallel shaft
gear unit, With IEC adapter

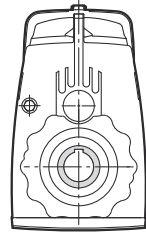
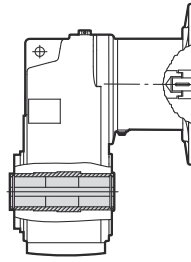

PD 32... - W

Delik milli, İki kademeli, Paralel şaftlı,
W kovanlı redüktör

Hollow shaft, Double reduction, Parallel shaft
gear unit, With free input shaft

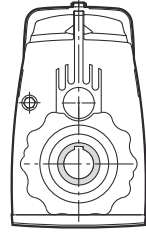
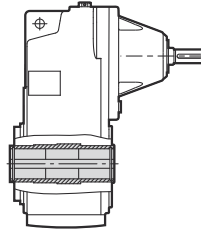

2) PD 32... **LT** - 80M/4A

Delik milli, İki kademeli, Paralel şaftlı,
Lastik takozlu, Motorlu redüktör

Hollow shaft, Double reduction, Parallel shaft gear unit,
With rubber buffer for torque arm and motor

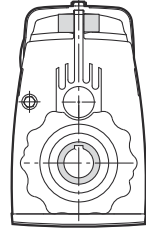
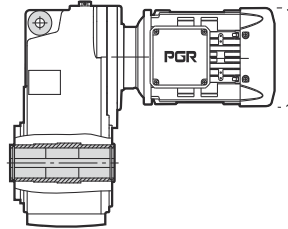

PD 32... **LT** - IEC 90

Delik milli, İki kademeli, Paralel şaftlı,
Lastik takozlu, IEC adaptörlü redüktör

Hollow shaft, Double reduction, Parallel shaft gear unit,
With rubber buffer for torque arm and IEC adapter

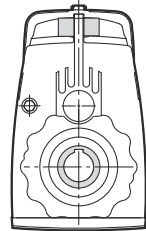
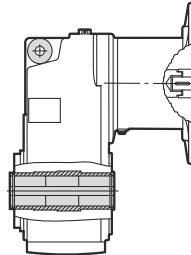

PD 32... **LT** - W

Delik milli, İki kademeli, Paralel şaftlı,
Lastik takozlu, W kovanlı redüktör

Hollow shaft, Double reduction, Parallel shaft gear unit,
With rubber buffer for torque arm and free input shaft

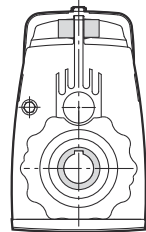
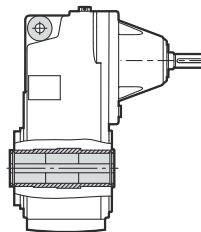

TR

ÜRÜNLERİMİZ

3) PD 32... Ç - 80M/4A

Delik millî, İki kademeli, Paralel şaftlı,
Çektirmeli, Motorlu redüktör

Hollow shaft, Double reduction, Parallel shaft gear unit,
With fixing element and motor

PD 32... Ç - IEC 90

Delik millî, İki kademeli, Paralel şaftlı,
Çektirmeli, IEC adaptörlü redüktör

Hollow shaft, Double reduction, Parallel shaft gear unit,
With fixing elements and IEC adapter

PD 32... Ç - W

Delik millî, İki kademeli, Paralel şaftlı,
Çektirmeli, W kovanlı redüktör

Hollow shaft, Double reduction, Parallel shaft gear unit,
With fixing elements and free input shaft

EN

PRODUCTS

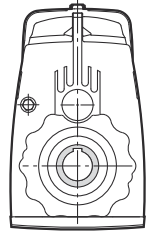
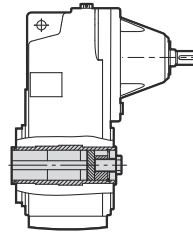
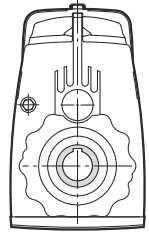
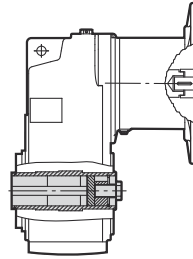
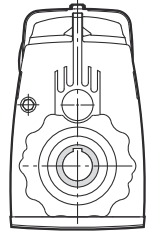
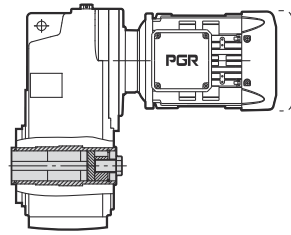

4) PD 32... Ç / LT - 80M/4A

Delik millî, İki kademeli, Paralel şaftlı,
Çektirmeli, Lastik takozlu, Motorlu redüktör

Hollow shaft, Double reduction, Parallel shaft gear unit,
With fixing element, rubber buffer for torque arm and motor

PD 32... Ç / LT - IEC 90

Delik millî, İki kademeli, Paralel şaftlı,
Çektirmeli, Lastik takozlu, IEC adaptörlü redüktör

Hollow shaft, Double reduction, Parallel shaft gear unit,
With fixing element, rubber buffer for torque arm and IEC adapter

PD 32... Ç / LT - W

Delik millî, İki kademeli, Paralel şaftlı,
Çektirmeli, Lastik takozlu, W kovanlı redüktör.

Hollow shaft, Double reduction, Parallel shaft gear unit,
With fixing element, rubber buffer for torque arm and free input shaft

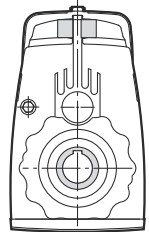
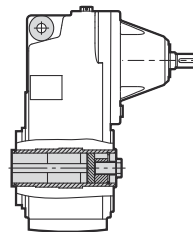
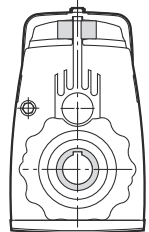
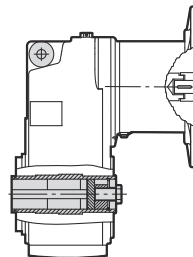
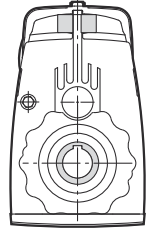
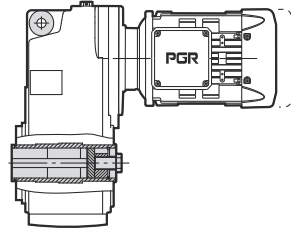

TR

ÜRÜNLERİMİZ

5) PD 32... **KS** - 80M/4A

Delik millî, İki kademeli, Paralel şaftlı,
Konik sıkırtmalı, Motorlu redüktör

Hollow shaft with shrink disc connector, Double reduction,
Parallel shaft gear unit, With motor

PD 32... **KS** - IEC 90

Delik millî, İki kademeli, Paralel şaftlı,
Konik sıkırtmalı, IEC adaptörlü redüktör

Hollow shaft with shrink disc connector, Double reduction,
Parallel shaft gear unit, With IEC adapter

PD 32... **KS** - W

Delik millî, İki kademeli, Paralel şaftlı,
Konik sıkırtmalı, W kovanlı redüktör

Hollow shaft with shrink disc connector, Double reduction,
Parallel shaft gear unit, With free input shaft

EN

PRODUCTS

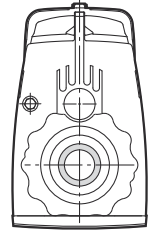
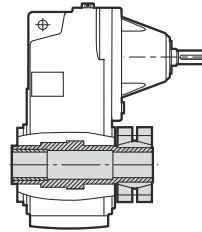
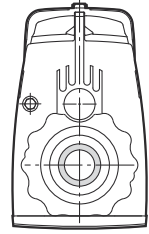
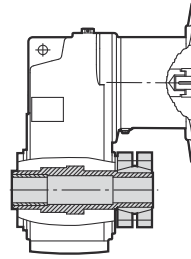
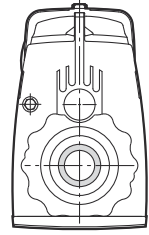
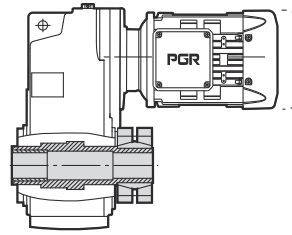

6) PD 32... **KS / LT** - 80M/4A

Delik millî, İki kademeli, Paralel şaftlı,
Konik sıkırtmalı, Lastik takozlu, Motorlu redüktör

Hollow shaft with shrink disc connector, Double reduction,
Parallel shaft gear unit, With rubber buffer for torque arm
and motor

PD 32... **KS / LT** - IEC 90

Delik millî, İki kademeli, Paralel şaftlı,
Konik sıkırtmalı, Lastik takozlu, IEC adaptörlü redüktör

Hollow shaft with shrink disc connector, Double reduction,
Parallel shaft gear unit, With rubber buffer for torque arm
and IEC adapter

PD 32... **KS / LT** - W

Delik millî, İki kademeli, Paralel şaftlı,
Konik sıkırtmalı, Lastik takozlu, W kovanlı redüktör

Hollow shaft with shrink disc connector, Double reduction,
Parallel shaft gear unit, With rubber buffer for torque arm
and free input shaft

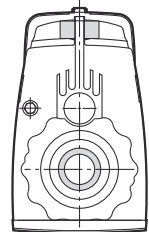
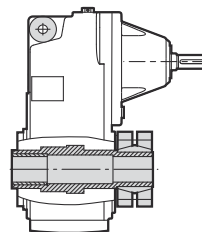
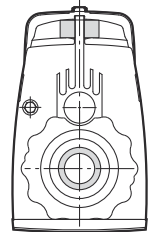
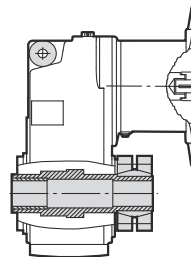
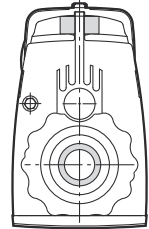
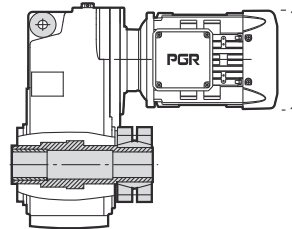

TR

ÜRÜNLERİMİZ

7) PD 32... B14 - 80M/4A

Delik millî, İki kademeli, Paralel şaftlı,
B14 Flanşlı, Motorlu redüktör

Hollow shaft, Double reduction, Parallel shaft
gear unit, With B14 flange and motor

PD 32... B14 - IEC 90

Delik millî, İki kademeli, Paralel şaftlı,
B14 Flanşlı, IEC adaptörlü redüktör

Hollow shaft, Double reduction, Parallel shaft
gear unit, With B14 flange and IEC adapter

PD 32... B14 - W

Delik millî, İki kademeli, Paralel şaftlı,
B14 Flanşlı, W kovanlı redüktör

Hollow shaft, Double reduction, Parallel shaft
gear unit, With B14 flange and free input shaft

EN

PRODUCTS

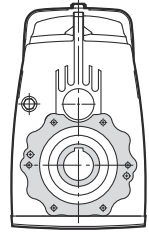
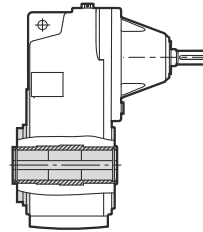
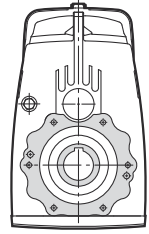
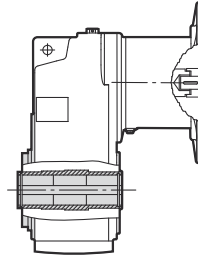
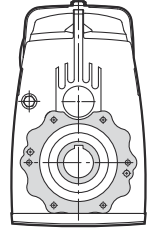
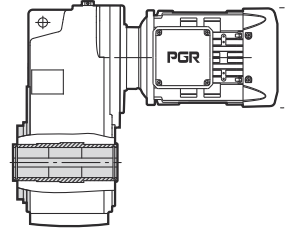

8) PD 32... Ç / B14 - 80M/4A

Delik millî, İki kademeli, Paralel şaftlı,
Çektirmeli, B14 Flanşlı, Motorlu redüktör

Hollow shaft, Double reduction, Parallel shaft
gear unit, With fixing element, B14 flange and motor

PD 32... Ç / B14 - IEC 90

Delik millî, İki kademeli, Paralel şaftlı,
Çektirmeli, B14 Flanşlı, IEC adaptörlü redüktör

Hollow shaft, Double reduction, Parallel shaft gear
unit, With fixing element, B14 flange and IEC adapter

PD 32... Ç / B14 - W

Delik millî, İki kademeli, Paralel şaftlı,
Çektirmeli, B14 Flanşlı, W kovanlı redüktör

Hollow shaft, Double reduction, Parallel shaft gear
unit, With fixing element, B14 flange and free input shaft

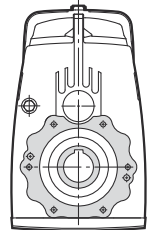
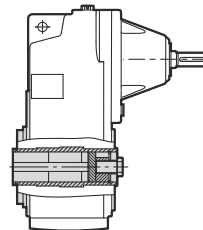
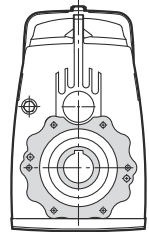
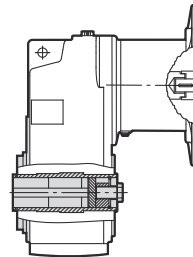
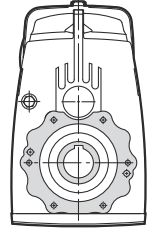
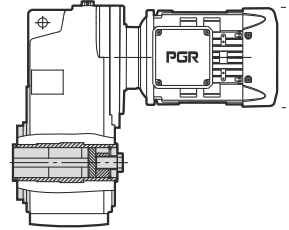

TR

ÜRÜNLERİMİZ

9) PD 32... **KS / B14** - 80M/4A

Delik millî, İki kademeli, Paralel şaftlı, Konik sıkırtmalı, B14 Flanşlı, Motorlu redüktör

Hollow shaft with shrink disc connector, Double reduction, Parallel shaft gear unit, With B14 flange and motor

PD 32... **KS / B14** - IEC 90

Delik millî, İki kademeli, Paralel şaftlı, Konik sıkırtmalı, B14 Flanşlı, IEC adaptörlü redüktör

Hollow shaft with shrink disc connector, Double reduction, Parallel shaft gear unit, With B14 flange and IEC adapter

PD 32... **KS / B14** - W

Delik millî, İki kademeli, Paralel şaftlı, Konik sıkırtmalı, B14 Flanşlı, W kovanlı redüktör.

Hollow shaft with shrink disc connector, Double reduction, Parallel shaft gear unit, With B14 flange and free input shaft

EN

PRODUCTS

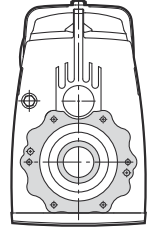
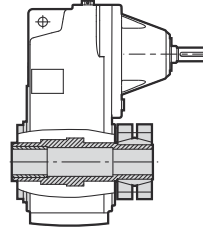
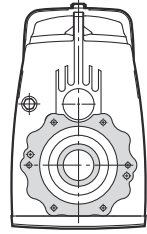
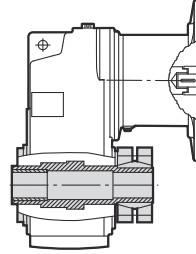
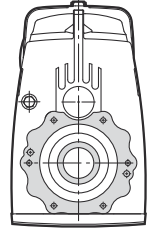
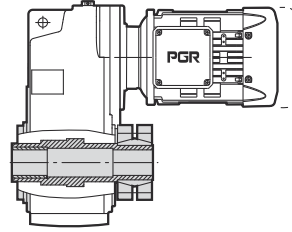

10) PD 32... **B5** - 80M/4A

Delik millî, İki kademeli, Paralel şaftlı, B5 Flanşlı, Motorlu redüktör

Hollow shaft, Double reduction, Parallel shaft gear unit, With B5 flange and motor

PD 32... **B5** - IEC 90

Delik millî, İki kademeli, Paralel şaftlı, B5 Flanşlı, IEC adaptörlü redüktör

Hollow shaft, Double reduction, Parallel shaft gear unit, With B5 flange and IEC adapter

PD 32... **B5** - W

Delik millî, İki kademeli, Paralel şaftlı, B5 Flanşlı, W kovanlı redüktör

Hollow shaft, Double reduction, Parallel shaft gear unit, With B5 flange and free input shaft

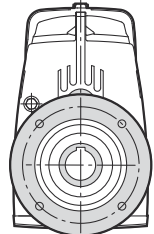
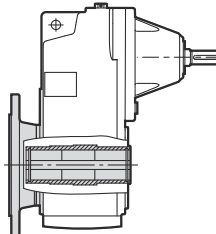
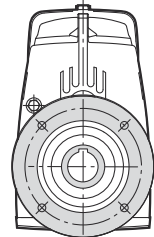
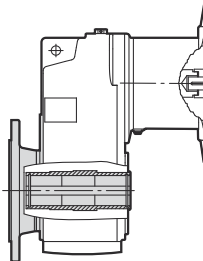
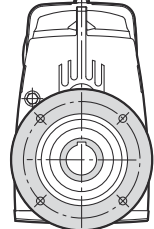
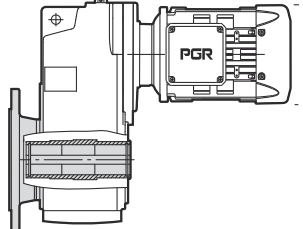

TR

ÜRÜNLERİMİZ

11) PD 32... Ç / B5 - 80M/4A

Delik millî, İki kademeli, Paralel şaftlı,
Çektirmeli, B5 Flanşlı, Motorlu redüktör

Hollow shaft, Double reduction, Parallel shaft gear
unit, With fixing element, B5 flange and motor

PD 32... Ç / B5 - IEC 90

Delik millî, İki kademeli, Paralel şaftlı,
Çektirmeli, B5 Flanşlı, IEC adaptörlü redüktör

Hollow shaft, Double reduction, Parallel shaft gear
unit, With fixing element, B5 flange and IEC adapter

PD 32... Ç / B5 - W

Delik millî, İki kademeli, Paralel şaftlı,
Çektirmeli, B5 Flanşlı, W kovanlı redüktör.

Hollow shaft, Double reduction, parallel shaft gear
unit, With fixing element, B5 flange and free input shaft

EN

PRODUCTS

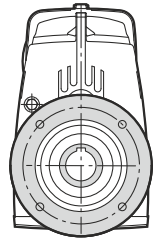
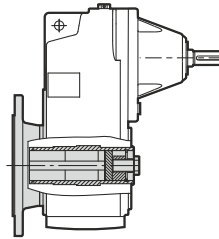
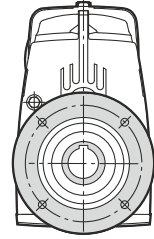
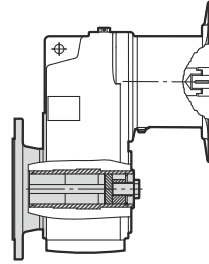
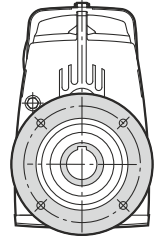
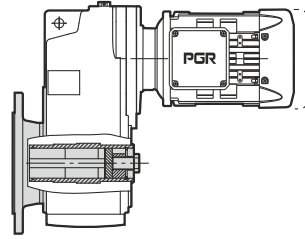

12) PD 32... KS / B5 - 80M/4A

Delik millî, İki kademeli, Paralel şaftlı, Konik sıkırtmalı,
B5 Flanşlı, Motorlu redüktör

Hollow shaft with shrink disc connector, Double reduction,
Parallel shaft gear unit, With B5 flange and motor

PD 32... KS / B5 - IEC 90

Delik millî, İki kademeli, Paralel şaftlı, Konik sıkırtmalı,
B5 Flanşlı, IEC adaptörlü redüktör

Hollow shaft with shrink disc connector, Double reduction,
Parallel shaft gear unit, With B5 flange and IEC adapter

PD 32... KS / B5 - W

Delik millî, İki kademeli, Paralel şaftlı, Konik sıkırtmalı,
B5 Flanşlı, W kovanlı redüktör

Hollow shaft with shrink disc connector, Double reduction,
Parallel shaft gear unit, With B5 flange and free input shaft

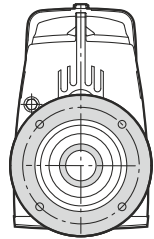
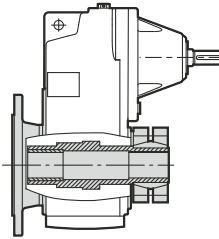
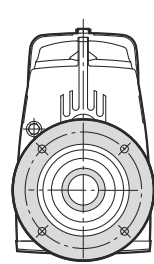
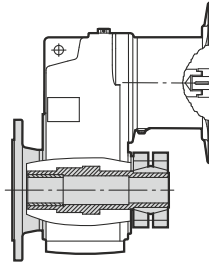
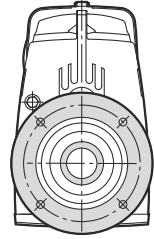
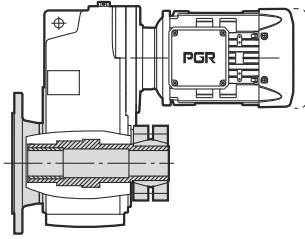

1) **PM 32... - 80M/4A**

Mil çıkışlı, İki kademeli, Paralel şaftlı, Motorlu redüktör

Solid shaft, Double reduction, Parallel shaft gear unit, With motor

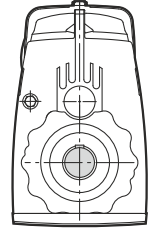
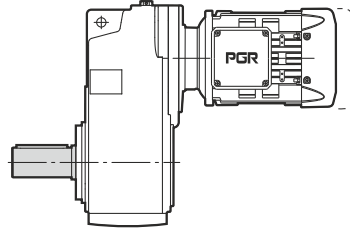

PM 32... - IEC 90

Mil çıkışlı, İki kademeli, Paralel şaftlı, IEC adaptörlü redüktör

Solid shaft, Double reduction, Parallel shaft gear unit, With IEC adapter

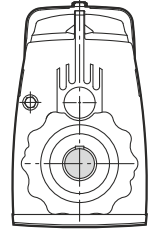
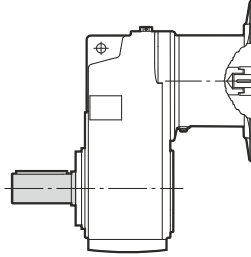

PM 32... - W

Mil çıkışlı, İki kademeli, Paralel şaftlı, W kovanlı redüktör.

Solid shaft, Double reduction, Parallel shaft gear unit, With free input shaft

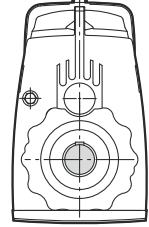
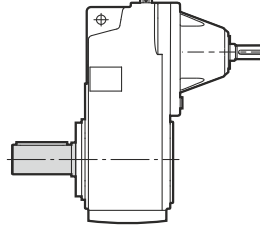

2) **PM 32... LT - 80M/4A**

Mil çıkışlı, İki kademeli, Paralel şaftlı, Lastik takozlu, Motorlu redüktör

Solid shaft, Double reduction, Parallel shaft gear unit, With rubber buffer for torque arm and motor

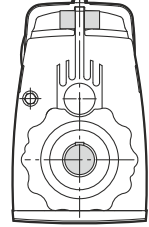
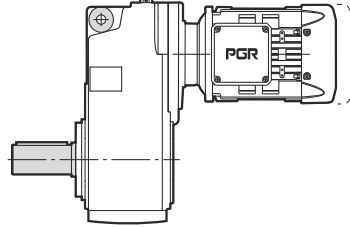

PM 32... LT - IEC 90

Mil çıkışlı, İki kademeli, Paralel şaftlı, Lastik takozlu, IEC adaptörlü redüktör

Solid shaft, Double reduction, Parallel shaft gear unit, With rubber buffer for torque arm and IEC adapter

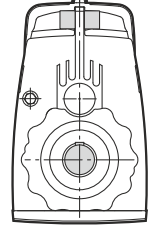
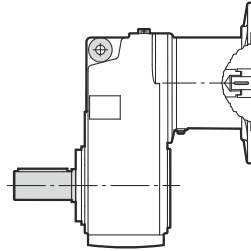

PM 32... LT - W

Mil çıkışlı, İki kademeli, Paralel şaftlı, Lastik takozlu, W kovanlı redüktör

Solid shaft, Double reduction, Parallel shaft gear unit, With rubber buffer for torque arm and free input shaft

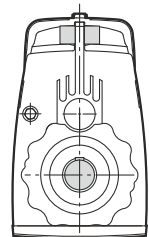
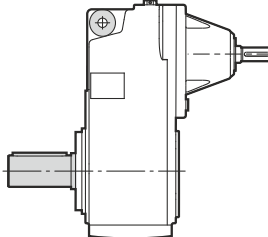

TR

ÜRÜNLERİMİZ

3) **PM 32... B14 - 80M/4A**

Mil çıkışlı, İki kademeli, Paralel şaftlı,
B14 Flanşlı, Motorlu redüktör

Solid shaft, Double reduction, Parallel shaft gear
unit, With B14 flange and motor

PM 32... B14 - IEC 90

Mil çıkışlı, İki kademeli, Paralel şaftlı,
B14 Flanşlı, IEC adaptörlü redüktör

Solid shaft, Double reduction, Parallel shaft gear
unit, With B14 flange and IEC adapter

PM 32... B14 - W

Mil çıkışlı, İki kademeli, Paralel şaftlı,
B14 Flanşlı, W kovanlı redüktör.

Solid shaft, Double reduction, Parallel shaft gear
unit, With B14 flange and free input shaft

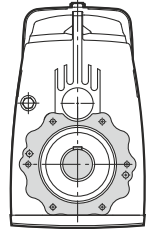
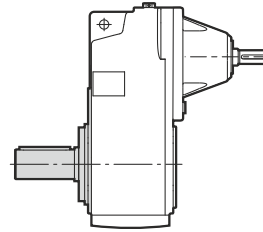
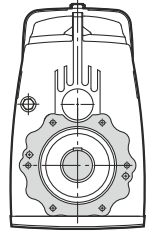
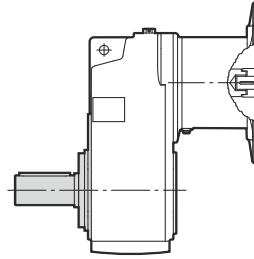
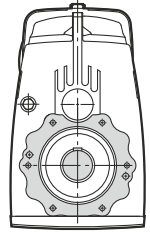
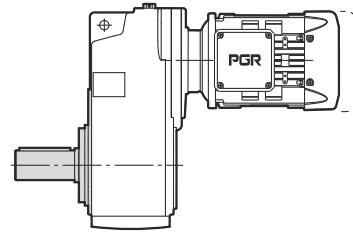

4) **PM 32... B5 - 80M/4A**

Mil çıkışlı, İki kademeli, Paralel şaftlı,
B5 Flanşlı, Motorlu redüktör

Solid shaft, Double reduction, Parallel shaft gear
unit, With B5 flange and motor

PM 32... B5 - IEC 90

Mil çıkışlı, İki kademeli, Paralel şaftlı,
B5 Flanşlı, IEC adaptörlü redüktör

Solid shaft, Double reduction, Parallel shaft gear
unit, With B5 flange and IEC adapter

PM 32... B5 - W

Mil çıkışlı, İki kademeli, Paralel şaftlı,
B5 Flanşlı, W kovanlı redüktör

Solid shaft, Double reduction, Parallel shaft gear
unit, With B5 flange and free input shaft

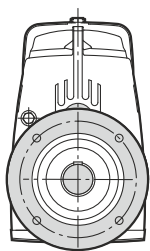
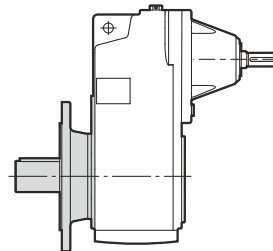
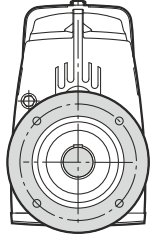
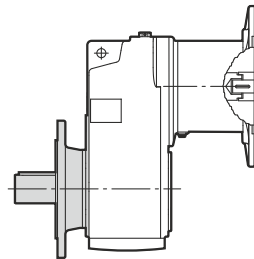
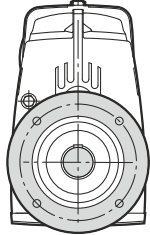
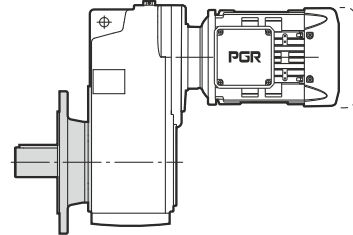

PD (PM)

93/52

410.49

B5 -

132 M / 4 BRE



PAM



IEC



W

Motorlu
With Motor

63
71
80
90
100
112
132
160
180
200
225
250
280
315

63
71
80
90
100
112
132
160
180
200
225
250
280
315



111 - 169

Gövde Büyüklüğü
Case Width

132 M

63 M
71 M
80 M
90 S/L
100 L
112 M
132 S/M
160 M/L
180 M/L
200 L
225 S/M
250 S/M/L
280 S/M/L
315 S/M/L

Kutup sayısı
Number of Poles

4

2
4
6
4 - 2
8 - 2

Diğer Kutup kombinasyonları istendiğinde karşılanacaktır.
Other pole combinations on request

Motor Aksesuarları
Motor Accessories

BRE

BRE
RG
SR
HL
TF
TW
WU
EF
ZF
DF
IG
KK/FK
RLS

21

Standart Ürünler
Available standard products
B5: B5 Flanşlı
B5: B5 Flange

LT

B14

Ç*

Ç/B14*

Ç/LT*

Ç/B5*

KS*

KS/B5*

KS/LT*

KS/B14*

B5

24 - 31

* İşareti ile belirtilen opsiyonlar sadece Polat Delik Millî seri için geçerlidir.
* Sign shows that this option is acceptable only for Polat Hollow Shaft gear unit series.

9
Gövde Büyüklüğü
Case Width

A0
B0
C1
1
2
3
4
5
6
7
8
9
10
11
12

3
Kademe
Reduction

2
3



111 - 169

PF GÖVDE
PF CASE

5
Gövde Büyüklüğü
Case Width

0
1
2
3
4
5

2
Kademe
Reduction

2



171 - 193

Tip :POLAT Delik Millî Redüktör (POLAT Mil Çıkışlı Redüktör) PD/PM
Type :POLAT Hollow Shaft Gear Unit (POLAT Solid Shaft Gear Unit) PD/PM

Not :Redüktör tiplerinden PD/PM A02, PD/PM B02 dişli üniteleri 2 kademeli, PD/PM C13 dişli ünitesi de 3 kademeli olup A0, B0 ve C1 gövde büyüklüğünü göstermemektedir.

Note :Gear units which are PD/PM A02, PD/PM B02 and PD/PM C13 are 2, 2 and 3 stage reduction respectively, but A0, B0 and C1 codes in this gear unit type don't determine case width.

TR

YAĞLAMA

Çalıştırmadan veya uzun süreli olarak depoya kaldırmadan önce ventildeki tapa sökülüp, havalandırma tapası takılarak aşırı basınç ve yağ sızıntısı önlenmelidir.

Redüktörler fabrikadan çalışmaya hazır ve mineral yağ doldurulmuş olarak gönderilirler. Bütün dişli üniteler aşağıdaki tablonun ortam sıcaklığı sütununda listesi verilen yağlayıcı (normal) ile dolu olarak sevk edilirler. Diğer ortam sıcaklıkları için listede verilen yağlayıcılar ek ücret karşılığında temin edilebilir.

Yağlayıcı her 10000 çalışma saatinde veya 2 yıl sonra değiştirilmelidir. Sentetik yağlar için yağ değişikliği her 20000 çalışma saatinde veya 4 yıl sonra yapılmalıdır. Zorlu çalışma koşullarında örneğin yüksek rutubet ve büyük sıcaklık değişimleri ve kötü çevre şartları gibi durumlarda daha kısa aralıklarla yağ değişimi yapılması tavsiye edilir. Yağ değişiminin üniteyi komple temizleme işlemi ile birleştirilmesi önerilir. Rulman içerisindeki gres her 10000 çalışma saatinde değiştirilmeli ve yeni gres ile doldurulmalıdır. Bu işlem yapılırken rulmanın 1/3 ünün gresle dolu olması sağlanmalıdır.

Not: Sentetik ve mineral yağlayıcılar birbirine karıştırılmamalıdır.

Note: Consider that different kinds of oil (synthetic and mineral oil) should not be mixed.

EN

LUBRICATION

Lubricating oil properties and selection of oil must be done correctly for the reducers to have long life and to run with good performance. In order to prevent oil leakage during long period storage due to inner pressure, top plug should be removed according to assembly type and venting plug should be mounted.

Reducers are delivered as being filled with mineral oil. Properties of oils depending on ambient temperature are presented at the following table. Gear units which are W or IEC adapter type and gear motors are charged with lubricant. Ambient temperature plays an important role for choosing lubricant. Relation between ambient temperature and properties of oils are shown in table.

Lubricants must be changed every 10000 hour or after two years, but this time changes when synthetic oil is used. Lubricants must be changed every 20000 hours or after four years if synthetic oil is used. However, operating conditions should be considered for changing oil time eg. in aggressive environment severe temperature changing, oil must be changed frequently. For bearings grease should be changed every 10000 running time and it should be done with fresh grease and least 1/3 of bearing must be covered.

Redüktör Tipi Type of gearbox	Yağ Tipi Type of Lubricant	Ortam Sıcaklığı Ambient Temp. °C	ISO vizkozite sınıfı ISO viscosity class	SHELL	MOBIL	BP	ESSO	DEA	ARAL	CASTROL	TRIBOL	KLÜBER
Helisel Dişli Redüktör	Mineral yağ	- 5...40 Normal	ISO VG 220	Shell Omala Oel 220	Mobilgear 600 XP 220	Energol GR-XP 220	Spartan EP 220	Deagear DX SAE 85W-90 Falcon CLP 220	Degol BG 220	Alpha SP 220 Alpha MW 220 Alpha MAX 220	Tribol 1100/220	Klüberoil GEM 1-220
	Mineral oil	-15...25	ISO VG 100	Shell omala Oel 100	Mobilgear 600 XP 150	Energol GR-XP 100	Spartan EP 100	Deagear DX SAE 80W Falcon CLP 150	Degol BG 100	Alpha SP 100 Alpha MW 100 Alpha MAX 220	Tribol 1100/100	Klüberoil GEM 1-100
	# - 50...-15	ISO VG 15	Shell Tellus Oel T 15	Mobil DTE 10 Excel 15	Bartran HV 15	Univis J 13	Alkraft Hydraulic Oil 15	Vitamol 1010	Hyspin SP 15 Hyspin ZZ 15	Tribol 770	Isoflex MT 30 rot	
Helical Gearboxes	Sentetik yağ Synthetic oil	- 25...80	ISO VG 220	Shell Tivela Oel WB	Mobil Glygoyle 30	Energol SG-XP 220	ESSO Glycolube 220	Polydea PGLP 220	Degol GS 220	Alphasyn PG 220	Tribol 800/220	Klübersynth GH 6 - 220
	Biyolojik Sentetik yağ Biodegradable oil	- 25...80	ISO VG 220					Plantogear 220 S	Bio-Degol S 220	Carelube GES 220	Tribol Bio Top1418/220	Klüber - Bio GM 2 - 220
	Gıda yağları Food - grade oil	- 25...80	ISO VG 220	Cassida 220	Mobil SHC Cibus 220		GEAR OIL FM 220	Renolin 220	Degol FG 220	OPTIMOL optileb GE 220	Tribol Food Proof 1810/220	Klüberoil 4UH1 - 220
Rulmanlar Anti Friction Bearings	Mineral yağlı gres Mineral oil grease	- 30...60 Normal		Alvania Fett R 3 oder Alvania Fett RL 3	Mobilux 3 Mobilux 2	Energol LS 3 Energol LS 2	Beacon 3 Beacon 2	Glissando 30 Glissando 20 Glissando FT 3	Aralub HL 3 Aralub HL 2 Aralub BAB EP 2	Spheerol AP 3 Spheerol AP 2 LZV - EP Spheerol EPL 2	Tribol 3030/100-2 Tribol 4020/220-2 Tribol 3785	Centoplex 3 Centoplex 2
	Sentetik gres Synthetic grease	# - 50...110		Aero Shell Grease 16 oder 7	Mobiltemp SHC 32		Beacon 325	Discor 8 - EP 2	Aralub SKL 2	Product 783/46	Tribol 3499	Isoflex Topas NB52

-30°C altında ve 60°C üzerindeki ortam sıcaklıklarında shafttaki sızdırmazlık elemanı için özel kalitedeki malzeme kullanılmalıdır.

Different materials should be used for sealing rings at operation temperature where temperature is below -30 °C and above 60 °C.

PD A02
PD B02
PD C13
PD 12
PD 22
PD 32
PD 42
PD 52

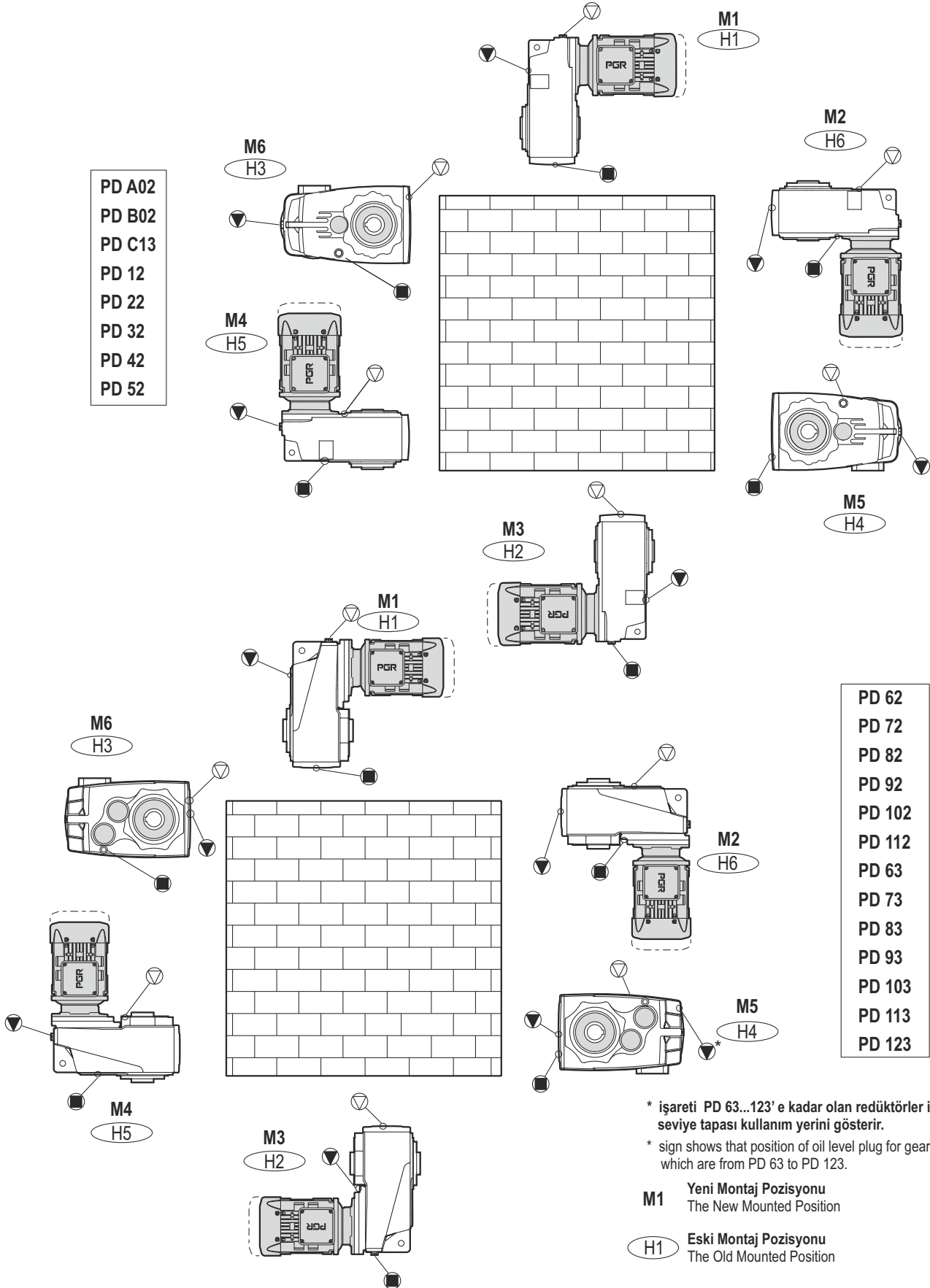

PD 62
PD 72
PD 82
PD 92
PD 102
PD 112
PD 63
PD 73
PD 83
PD 93
PD 103
PD 113
PD 123

* işareti PD 63...123' e kadar olan redüktörler için yağ seviye tapası kullanım yerini gösterir.

* sign shows that position of oil level plug for gear units which are from PD 63 to PD 123.

M1 Yeni Montaj Pozisyonu
The New Mounted Position

H1 Eski Montaj Pozisyonu
The Old Mounted Position

○ Havalandırma tapası / Vent plug

● Boşaltma tapası / Drain plug

▼ Yağ Seviye tapası / Oil level

TR

MONTAJ POZİSYONLARI

EN

MOUNTING POSITIONS

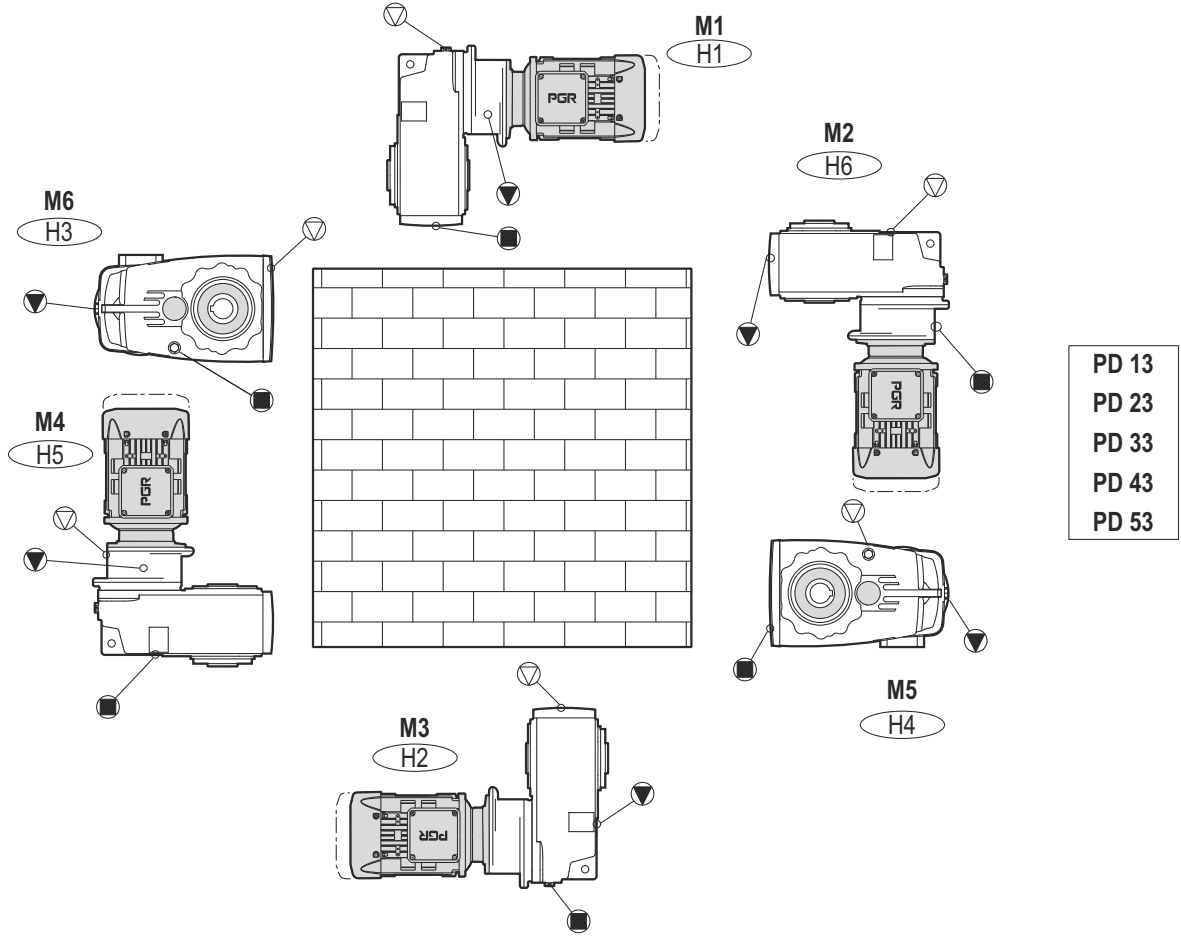

TERMİNAL KUTUSU VE KABLO GİRİŞ YÖNLERİ / POSITION OF TERMINAL BOX AND CABLE ENTRY

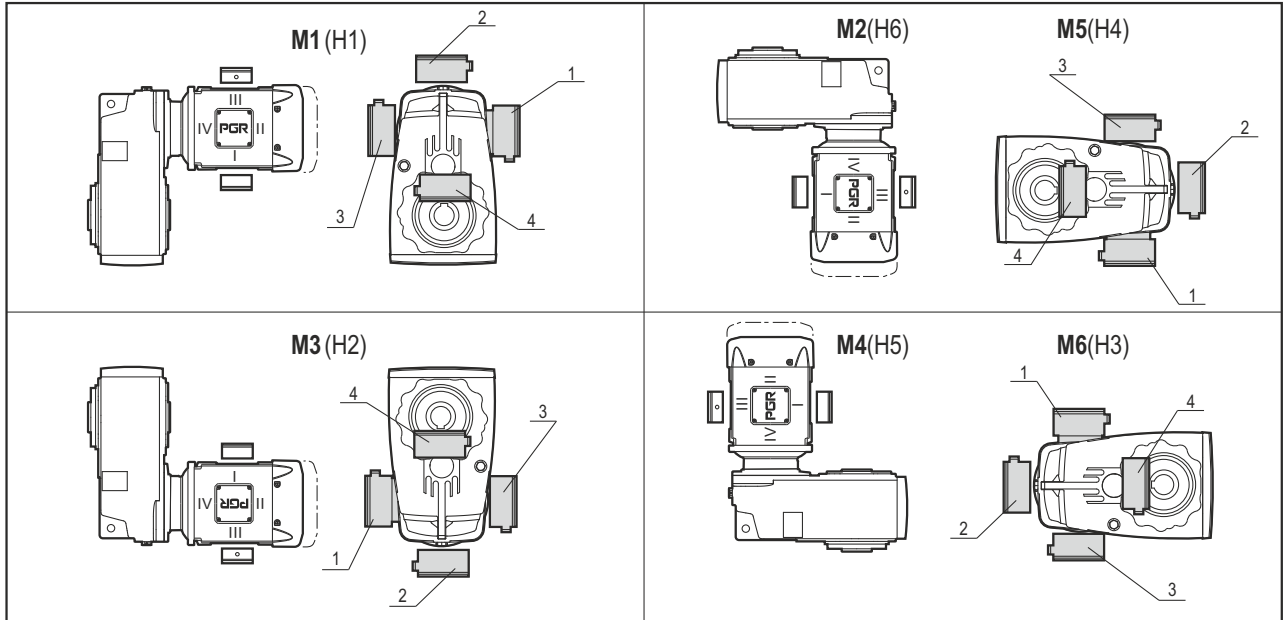

M1 Yeni Montaj Pozisyonu
The New Mounted Position

H1 Eski Montaj Pozisyonu
The Old Mounted Position

○ Havalandırma tapası / Vent plug

● Boşaltma tapası / Drain plug

▼ Yağ Seviye tapası / Oil level

PM A02
PM B02
PM C13
PM 12
PM 22
PM 32
PM 42
PM 52

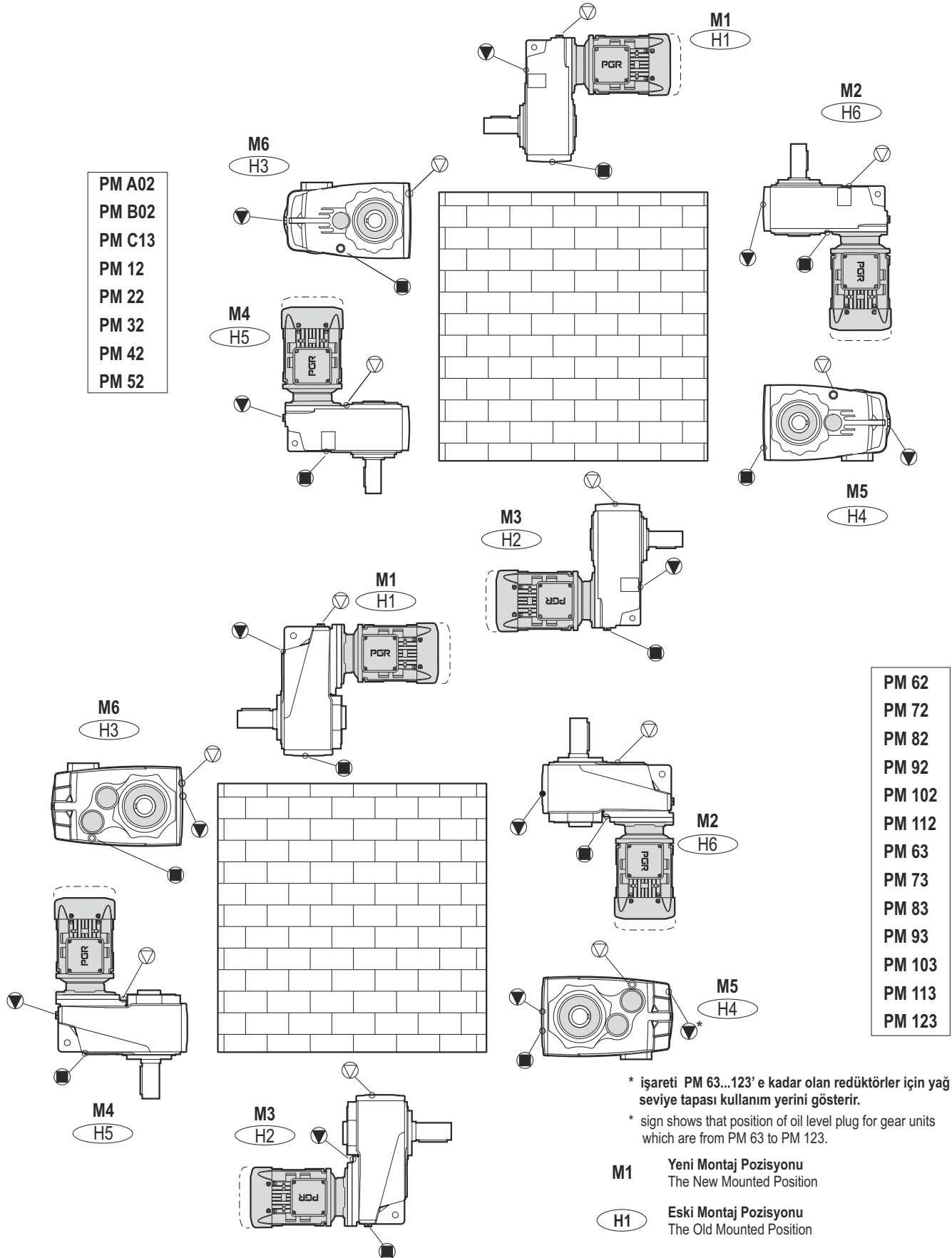

PM 62
PM 72
PM 82
PM 92
PM 102
PM 112
PM 63
PM 73
PM 83
PM 93
PM 103
PM 113
PM 123

* işareti PM 63...123' e kadar olan redüktörler için yağ seviye tapası kullanım yerini gösterir.

* sign shows that position of oil level plug for gear units which are from PM 63 to PM 123.

M1 Yeni Montaj Pozisyonu
The New Mounted Position

H1 Eski Montaj Pozisyonu
The Old Mounted Position

○ Havalandırma tapası / Vent plug

● Boşaltma tapası / Drain plug

▼ Yağ Seviye tapası / Oil level

TR

MONTAJ POZİSYONLARI

EN

MOUNTING POSITIONS

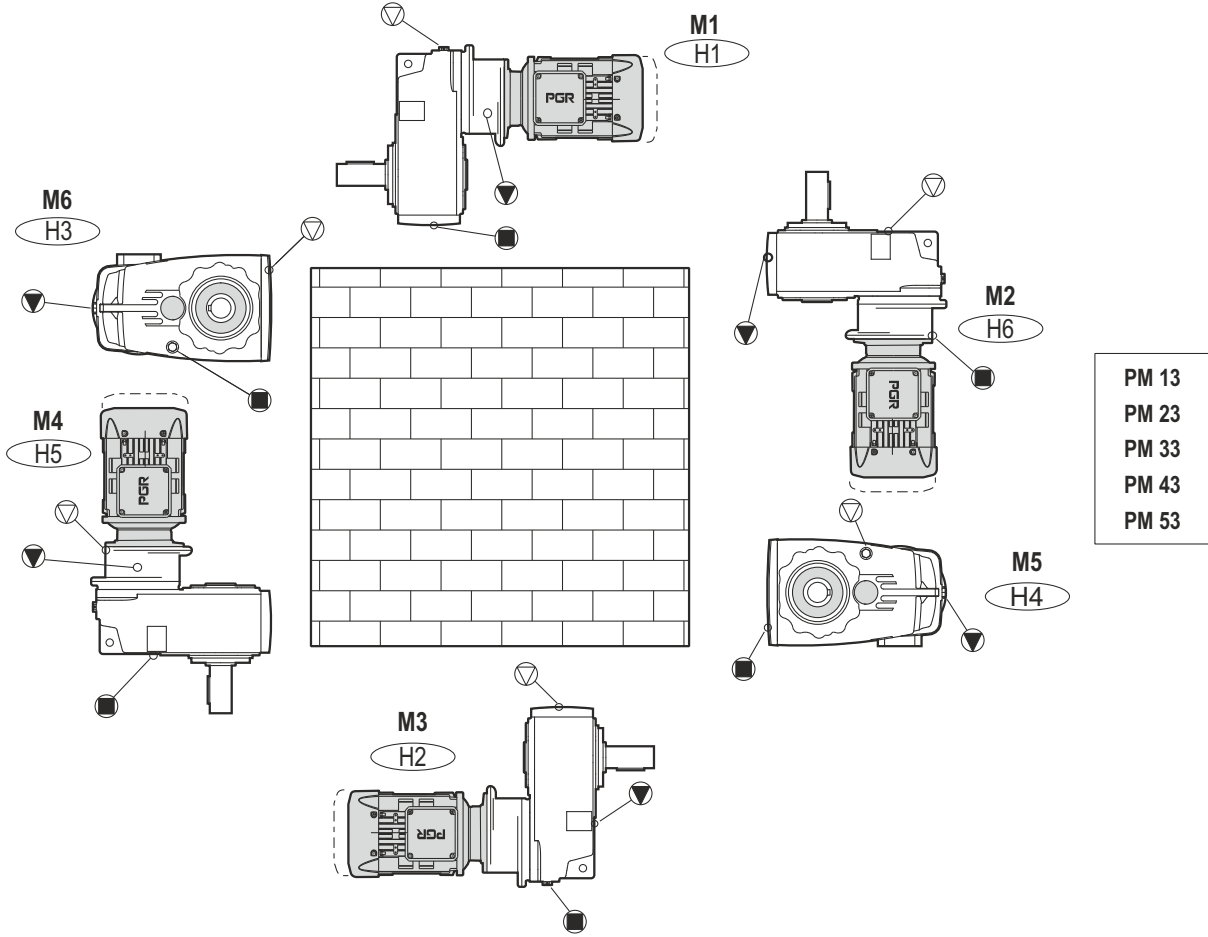

TERMİNAL KUTUSU VE KABLO GİRİŞ YÖNLERİ / POSITION OF TERMINAL BOX AND CABLE ENTRY

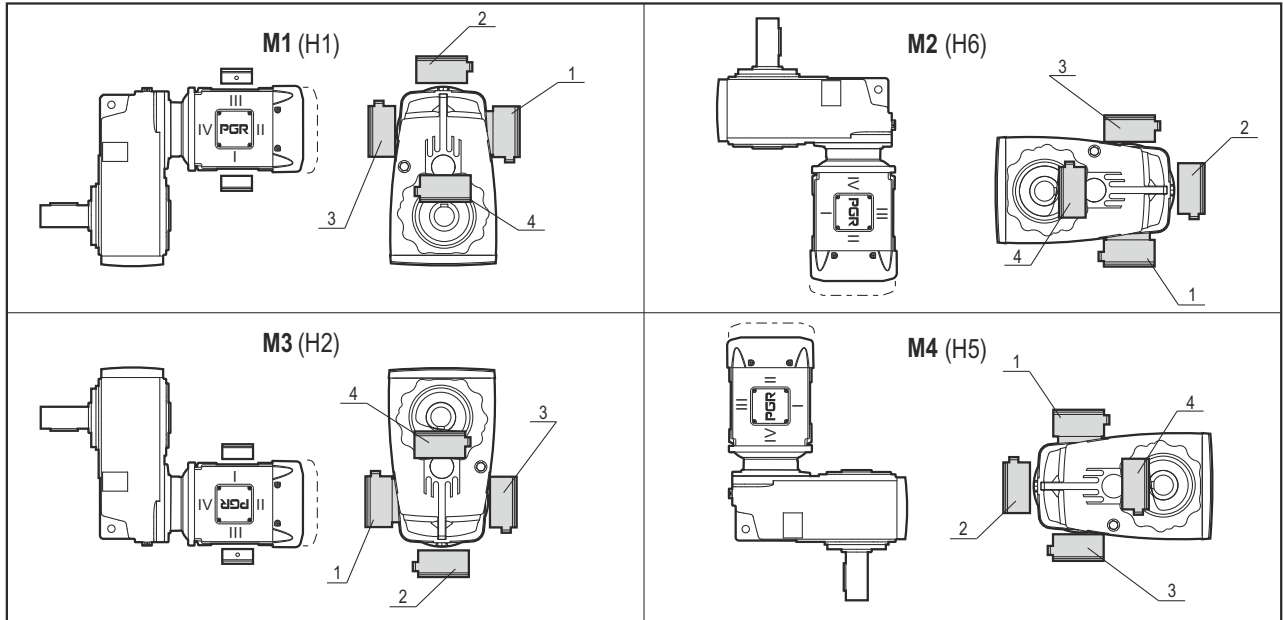

M1 Yeni Montaj Pozisyonu
The New Mounted Position

H1 Eski Montaj Pozisyonu
The Old Mounted Position

○ Havalandırma tapası / Vent plug

● Boşaltma tapası / Drain plug

▼ Yağ Seviye tapası / Oil level

TR

MONTAJ POZİSYONLARI

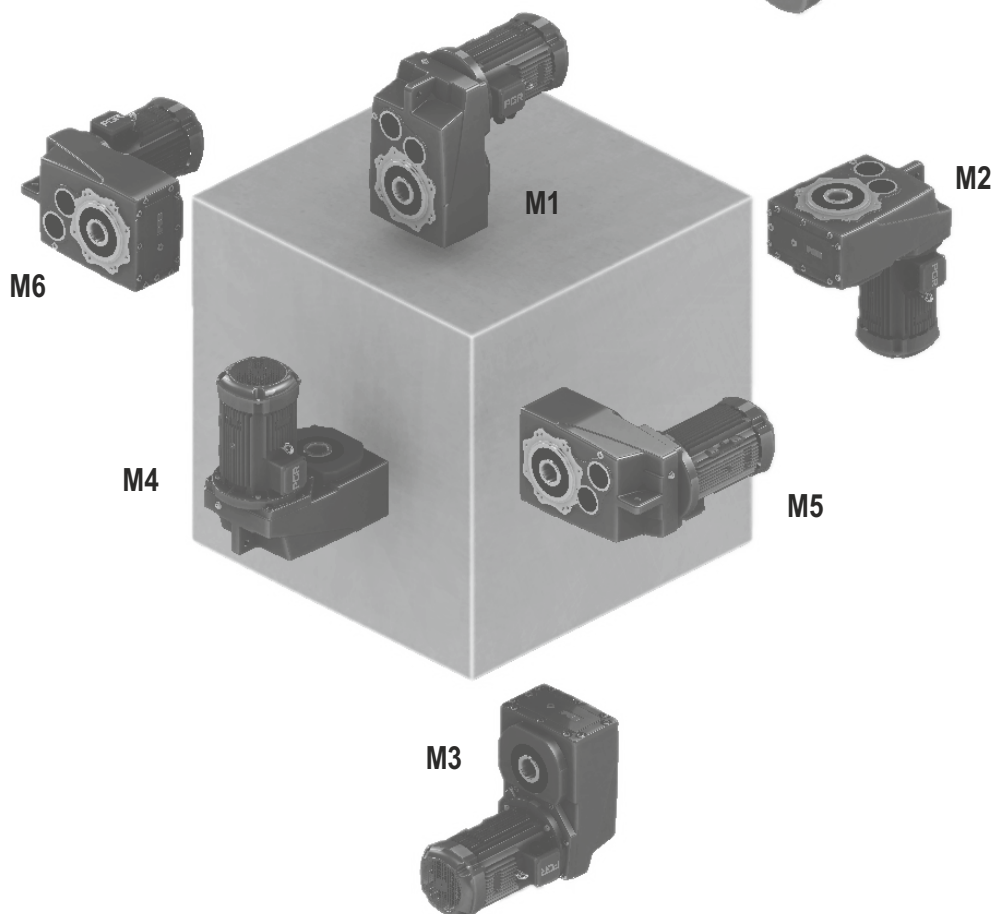
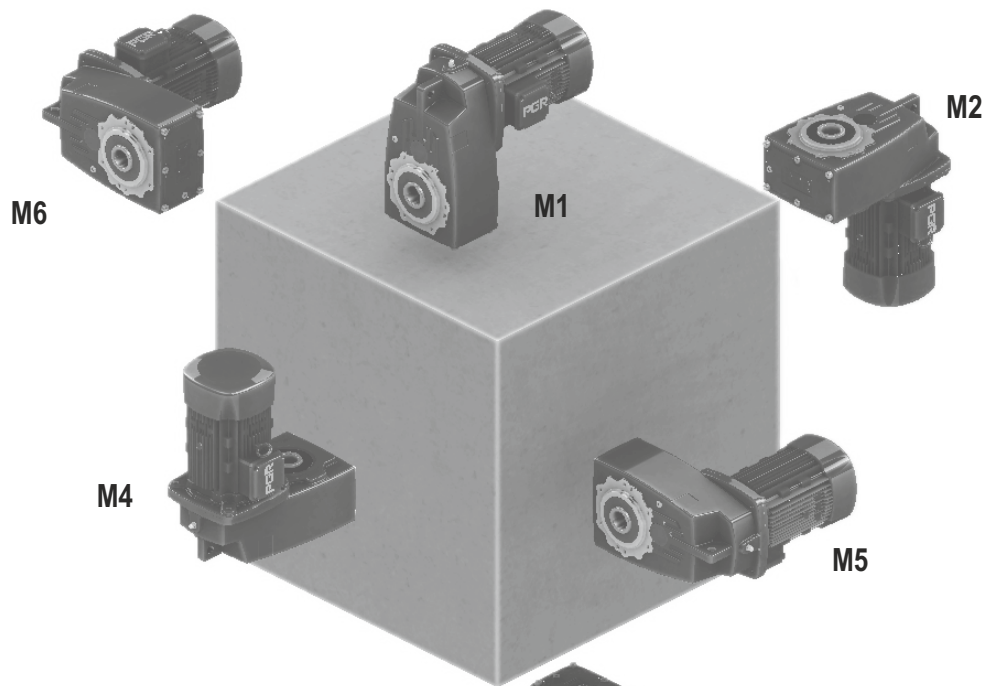
PD A02 - PD 52
PD C13 - PD 53PD 62 - PD 112
PD 63 - PD 123

TR

MONTAJ POZİSYONLARI

EN

MOUNTING POSITIONS

PM A02 - PM 52
PM C13 - PM 53

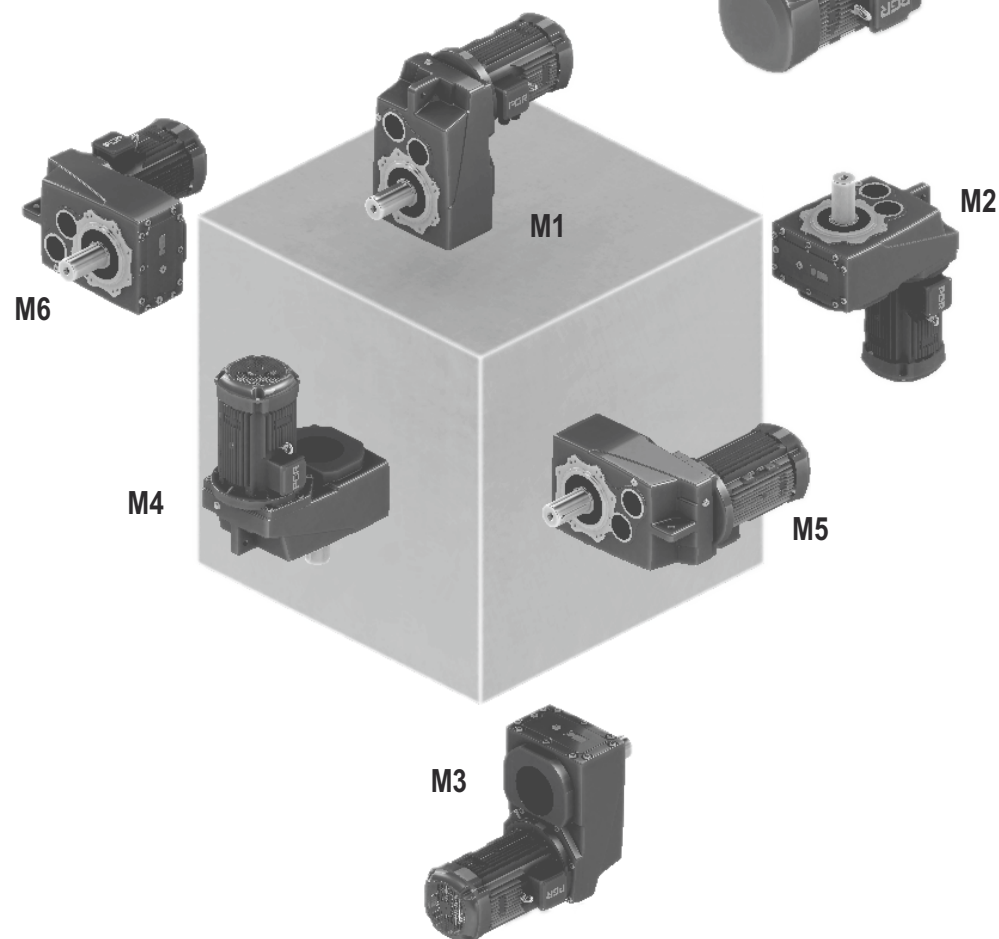
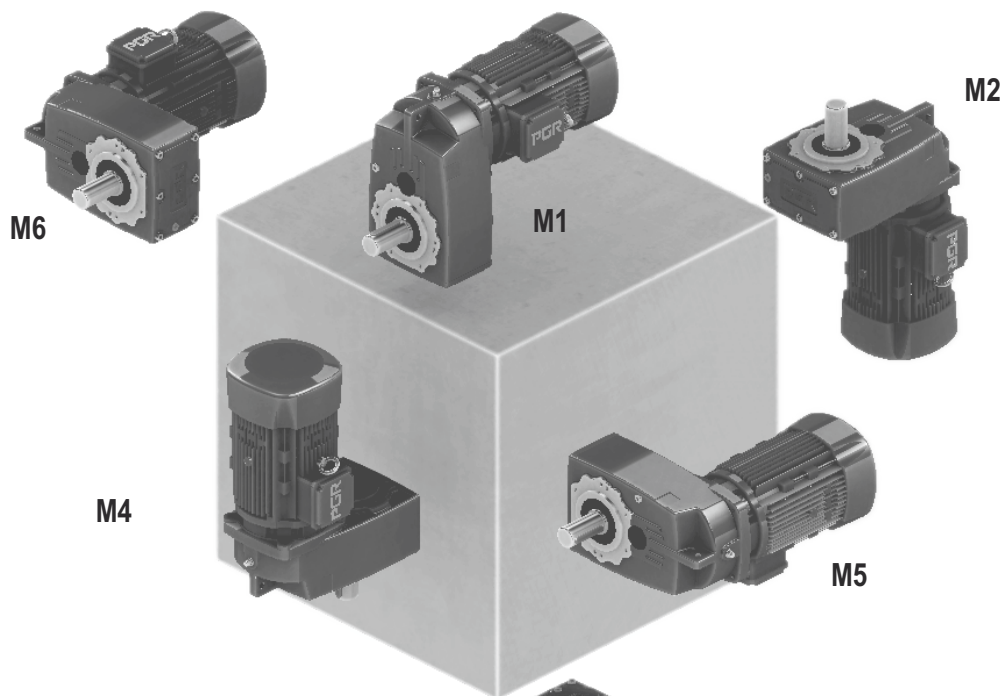





PM 62 - PM 112
PM 63 - PM 123





TR





YAĞ MİKTAR TABLOSU





EN

LUBRICATION LEVELS

(Litre) (L)						
 34 - 39	M1	M2	M3	M4	M5	M6
 34 - 37	H1	H6	H2	H5	H4	H3
PD/PM A02	0.50	0.70	0.50	0.60	0.35	0.35
PD/PM B02	0.80	1.10	0.90	1.20	0.75	0.75

(Litre) (L)						
 34 - 39	M1	M2	M3	M4	M5	M6
 34 - 37	H1	H6	H2	H5	H4	H3
PD/PM 12	0.90	1.40	1.00	1.30	0.90	0.90
PD/PM 22	1.70	2.50	2.10	2.10	1.50	1.50
PD/PM 32	3.20	4.20	3.70	4.20	2.70	2.70
PD/PM 42	4.80	6.60	5.40	5.50	4.20	4.20
PD/PM 52	7.60	9.00	8.50	9.50	6.60	6.60

(Litre) (L)						
 34 - 39	M1	M2	M3	M4	M5	M6
 34 - 37	H1	H6	H2	H5	H4	H3
PD/PM 62	16.00	17.50	15.50	17.60	10.10	13.50
PD/PM 72	24.00	25.00	21.00	27.10	16.10	20.00
PD/PM 82	35.00	40.00	33.50	41.50	28.50	30.50

(Litre) (L)						
 34 - 39	M1	M2	M3	M4	M5	M6
 34 - 37	H1	H6	H2	H5	H4	H3
PD/PM 92	68.00	77.00	55.50	75.00	50.00	56.00
PD/PM 102	90.10	90.10	40.10	90.10	60.10	82.10
PD/PM 112	166.00	161.00	146.00	196.00	101.00	141.00

M1 Yeni Montaj Pozisyonu
The New Mounted Position





H1 Eski Montaj Pozisyonu
The Old Mounted Position





TR





YAĞ MİKTAR TABLOSU





EN

LUBRICATION LEVELS

(Litre) (L)						
 34 - 39	M1	M2	M3	M4	M5	M6
 34 - 37	(H1)	(H6)	(H2)	(H5)	(H4)	(H3)
PD/PM C13	1.40	2.40	1.50	2.20	1.80	1.80

(Litre) (L)						
 34 - 39	M1	M2	M3	M4	M5	M6
 34 - 37	(H1)	(H6)	(H2)	(H5)	(H4)	(H3)
PD/PM 13	1.50	1.70	1.50	1.80	1.10	1.10
PD/PM 23	1.80	2.70	2.00	3.10	1.60	1.60
PD/PM 33	4.20	4.40	3.40	5.50	3.00	3.00
PD/PM 43	6.00	7.80	5.00	8.70	4.70	4.70
PD/PM 53	11.50	12.00	6.80	13.50	7.00	7.00

(Litre) (L)						
 34 - 39	M1	M2	M3	M4	M5	M6
 34 - 37	(H1)	(H6)	(H2)	(H5)	(H4)	(H3)
PD/PM 63	16.00	17.50	10.50	18.10	14.50	12.50
PD/PM 73	22.10	20.10	16.10	26.00	22.00	18.50
PD/PM 83	33.80	37.50	25.10	38.50	34.00	29.00

(Litre) (L)						
 34 - 39	M1	M2	M3	M4	M5	M6
 34 - 37	(H1)	(H6)	(H2)	(H5)	(H4)	(H3)
PD/PM 93	70.00	73.00	45.10	74.10	62.50	54.00
PD/PM 103	84.50	97.50	74.00	101.00	74.00	66.00
PD/PM 113	161.00	156.00	141.00	211.00	156.00	136.00
PD/PM 123	161.00	156.00	141.00	211.00	156.00	136.00

M1 Yeni Montaj Pozisyonu
The New Mounted Position

(H1) Eski Montaj Pozisyonu
The Old Mounted Position

TR

KİLİT

Opsiyonel olarak kilitlelerimiz mevcuttur. Bu kilitleler tek yöne dönmeye izin verirken, diğer yöne dönmeyi engeller. 63 gövde ve üzeri üç fazlı motorlar, W kovanları yağlanması yapılmış kilit ile donatılabilir. Bu kilitleler çıkartılabilir, merkezkaç kuvveti tarafından kontrol edilir ve yaklaşık olarak 900 d/dk üzerine çıktıktan sonra aşınmaya maruz kalır.

Kilit mekanizmalı redüktörler için **çıkış şaftının veya milinin dönme yönünün verilmesi gerekir**. Dönme yönü çıkış şaftına veya çıkış miline göre düzenlenir.

Kararlaştırılan dönme yönü için, tarif edilen dönme yönü her zaman çıkış şaftına veya miline göre düzenlenir. Delik milli redüktörler ise konik sıkırtma tarafından belirlenir.

DİKKAT: Motoru ve sistemi çalıştırmadan önce redüktörün dönme yönünü kontrol ediniz. Redüktör üzerindeki oklar dönme yönünü gösterir.

Bloke edilen yön **CCW** ise Dönme Yönü **CW**

Bloke edilen yön **CW** ise Dönme Yönü **CCW**

CW : Saat yönü

CCW : Saat yönü tersi

EN

BACKSTOP

Backstop system is available for all types of helical gear unit. Lubricated backstop system could be used optionally for motor size 63 and greater, W cylinder. Backstop system permits just one direction rotation it resists another direction rotation. Rotation speed is important for abrasion. Nearly 900 min⁻¹ and greater rotation speed influence abrasion.

Please, determine direction of rotation when you offer. **Direction of rotation should be determined according to output shaft.**

Arrows which is designated by 'CW' or 'CCW' shows locking direction when you have a view of the face of output shaft end. For hollow shafts gearboxes this direction determined by shrinkdisc side.

Precaution: When you receive gear units, please check direction of rotation before running or installation to avoid damage.

If Locking direction is **CCW**, Rotational direction is **CW**

If Locking direction is **CW**, Rotational direction is **CCW**

CW : Clockwise rotation

CCW : Counterclockwise rotation

PD

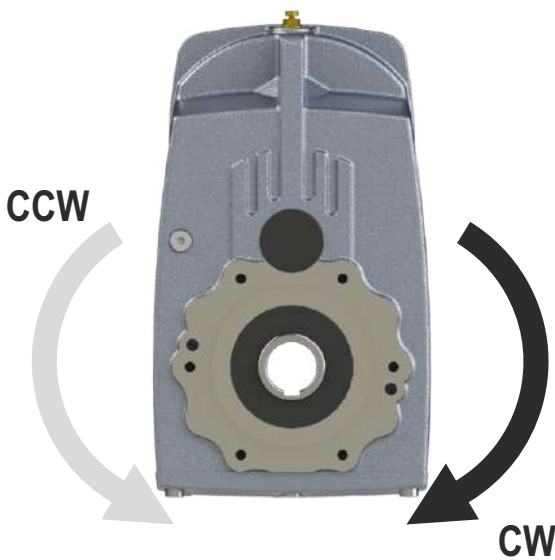

PM

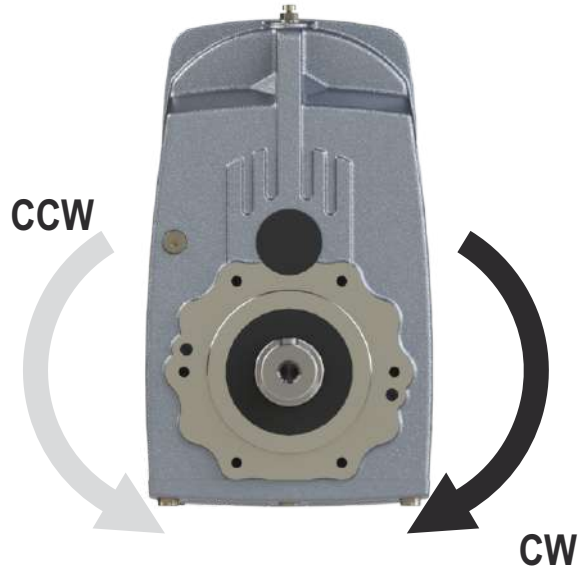

TR

TOLERANSLAR

MOTOR VE REDÜKTÖRLERDE BOYUT - ÇİZİM BİLGİLERİ

Motor ölçüleri, motor markasına göre farklılık gösterebilir.

DELİK MİLLİLER

Delik mil çapı toleransı için (DIN 748) ISO H7.

Müşteri mili çap toleransı ISO h6. "H" yüklenme tipi bulunuyorsa ISO k6

IEC - ADAPTÖR

Flanş merkezi çap toleransı için ISO H7

GİRİŞ VE ÇIKIŞ ŞAFTLARI

Mil çapı toleransı (DIN 748) :

Ø 14 ile Ø 50 mm arası için ISO k6,

Ø 50 mm üzeri için ISO m6

Şaftta dış çekilmiş delikler için DIN 332/2 ye göre;

= Ø 13 - Ø 16	M5
> Ø 16 - Ø 21	M6
> Ø 21 - Ø 24	M8
> Ø 24 - Ø 30	M10
> Ø 30 - Ø 38	M12
> Ø 38 - Ø 50	M16
> Ø 50 - Ø 85	M20
> Ø 85 - Ø 130	M24



111 - 169

Kama yatakları DIN 6885

Şaft boyu "h" DIN 747

FLANŞLAR

Flanş merkezi çap toleransı (DIN 42948);

≤ Ø 230 mm' ye kadar ISO j6,

> Ø 230 mm üzeri için ISO h6

EN

TOLERANCES

DIMENSIONS OF GEARED MOTORS AND GEARBOXES - DRAWING INFORMATION

Motor dimension could be changed according to customer purchase.

HOLLOW SHAFTS

Tolerance of hollow shaft (DIN 748) ISO H7.

Tolerance of customer's solid shaft which is used for hollow shaft ISO h6, with type of load classification 'H' which is heavy-shock operation ISO k6.

IEC - ADAPTER

Diameter tolerance of flange centering is machined according to ISO H7.

INPUT AND OUTPUT SHAFT

Tolerances of solid shaft (DIN 748) :

between Ø 14 - Ø 50 mm to ISO k6,

greater than Ø 50 mm to ISO m6.

Tapped center hole is machined according to DIN 332, sheet 2;

= Ø 13 - Ø 16	M5
> Ø 16 - Ø 21	M6
> Ø 21 - Ø 24	M8
> Ø 24 - Ø 30	M10
> Ø 30 - Ø 38	M12
> Ø 38 - Ø 50	M16
> Ø 50 - Ø 85	M20
> Ø 85 - Ø 130	M24



111 - 169

Keyways are machined according to DIN 6885, sheet 1

Shaft heights are machined according to "h" to DIN 747

FLANGES

Diameter tolerance of flange centering is machined according to (DIN 42948);

≤ Ø 230 mm to ISO j6,

> Ø 230 mm to ISO h6

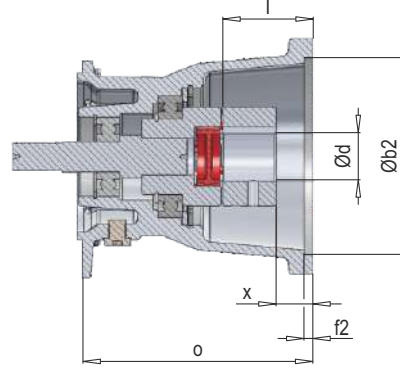
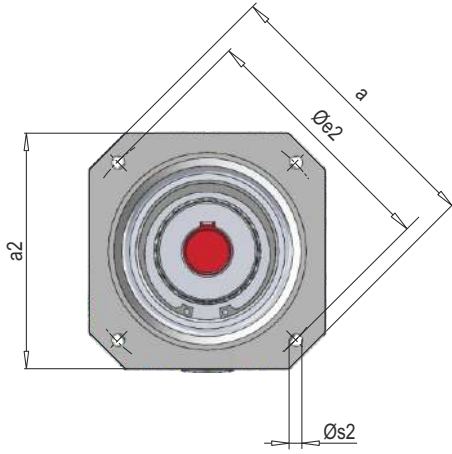

Redüktör Tipi Gear Unit Type	Motor Büyüklüğü / Motor Size							Şaft Ebatı Shaft Size		Silindir Cylinder	M _{knom} [Nm]	Adaptör Tipi Adapter Type
	a	a2	Øb2	Øe2	f2	s2	x	Ød	l	o		
PD/PM 12	120	96	80	100	4	M6	15	19	40	124	10	Servo 100 / 160 S
PD/PM 12	165	126	110	130	4	M8	20	24	50	136	35	Servo 130 / 160 S
PD/PM 22 , PD/PM 32	155	126	110	130	4	M8	20	24	50	150	35	Servo 130 / 250 S
PD/PM 12	186	155	130	165	5	M10	23	32	58	151	95	Servo 165 / 160 S
PD/PM 22 , PD/PM 32	186	155	130	165	5	M10	23	32	58	166	95	Servo 165 / 250 S
PD/PM 22 , PD/PM 32	240	192	180	215	5	M12	45	38	80	187	95	Servo 215/ 250 S
PD/PM 42 , PD/PM 52	240	192	180	215	5	M12	24	38	80	229	310	Servo 215/ 300 S
PD/PM 42 , PD/PM 52	350	260	250	300	5	M16	26	48	82	231	310	Servo 300/ 300 S
PD/PM 62 , PD/PM 72 PD/PM 82 , PD/PM 92	350	260	250	300	5	M16	26	48	82	249	310	Servo 300/ 350 S

SEP tipi servo motor bağlantı adaptörünün bağlantısı kamalı olarak yapılmaktadır. SEK tiplerinde ise servo motor adaptörünün bağlantısı setuskur civata sıkırtması ile yapılmaktadır. Servo motor bağlantı adaptörünün bağlantı flanşının farklı olması durumunda yüksek adetteki siparişler üretime alınır.

For connecting SEP adapter which is shown above on this page, servo motor's output shaft is designed with locking key. For connecting SEK type adapter, connecting is supplied with a clamp coupling sleeve. An intermediate flange is required when other servo motor types are used with IEC adapter. Offers are manufactured gladly by PGR.

TR

PD/PM B14 FLANŞLI

EN

PD/PM WITH B14 FLANGE

PD\PM B14 FLANŞLI ÖLÇÜ TABLOSU
DIMENSION TABLE OF PD/PM WITH B14 FLANGE

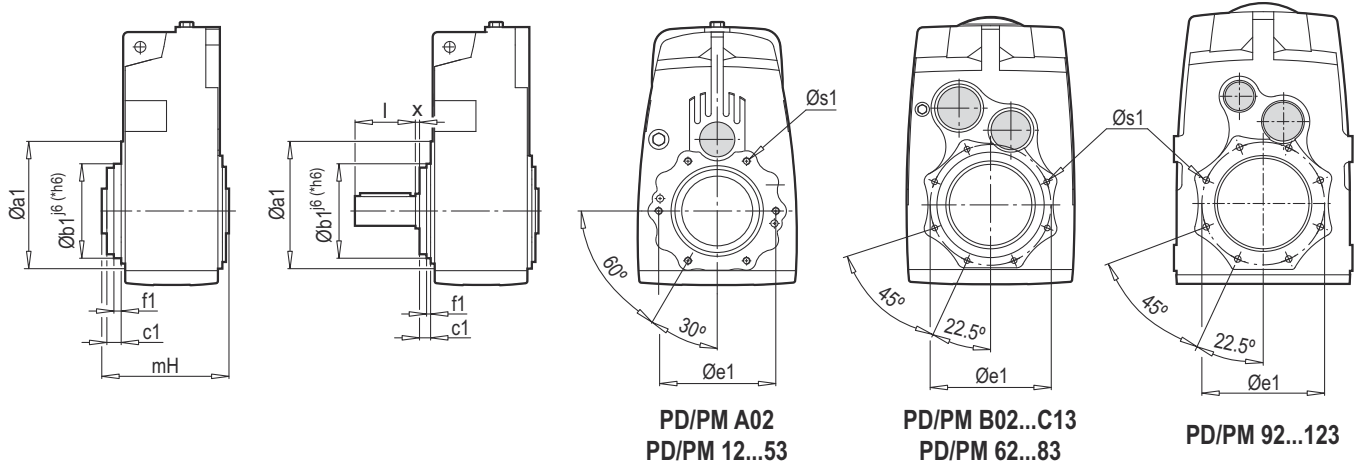

Tip / Type	Øa1	Øb1	c1	Øe1	f1	Øs1	mH	l	x
PD/PM A02 B14	100	70	-	85	3	M8X14	100	50	3
PD/PM B02 B14	120	80	-	100	3	M6X10	122	50	3
PD/PM C13 B14	140	95	-	115	6	M8X13	176	60	3
PD/PM 12 B14 PD/PM 13 B14	140	95	13	115	6	M8X13	122	60	4
PD/PM 22 B14 PD/PM 23 B14	160	110	12	130	5	M8X13	139	70	5
PD/PM 32 B14 PD/PM 33 B14	200	130	-	165	7	M10X16	174	90	6
PD/PM 42 B14 PD/PM 43 B14	230	160	11	194	5	M12X20	195	110	7
PD/PM 52 B14 PD/PM 53 B14	250	180	9	215	5	M12X20	230	130	7.5
PD/PM 62 B14 PD/PM 63 B14	300	230	11	265	4	M12X20	290	140	8.5
PD/PM 72 B14 PD/PM 73 B14	350	*250	11	300	5	M16X25	310	170	6
PD/PM 82 B14 PD/PM 83 B14	400	*300	13	350	5	M16X25	366	210	7
PD/PM 92 B14 PD/PM 93 B14	450	*350	14	400	5	M20X30	430	250	10
PD 102-103 KS-B14 PM 102-103 B14	550	*450	-	500	8	M24X36	660	300	10
PD 112-113 KS-B14 PM 112-113 B14	550	*450	-	500	8	M24X36	675	300	10
PD 123 KS-B14 PM 123 B14	550	*450	18	500	8	M24X36	845	300	10

TR

MONTAJ ÖLÇÜLERİ

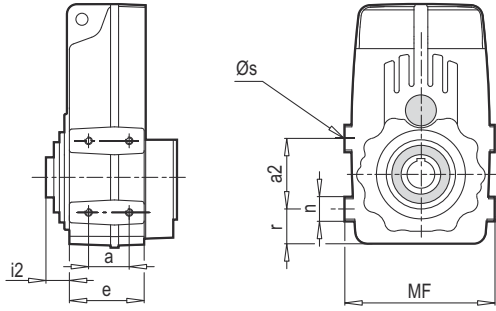

PD A02...C13

EN

INSTALLATION DIMENSIONS

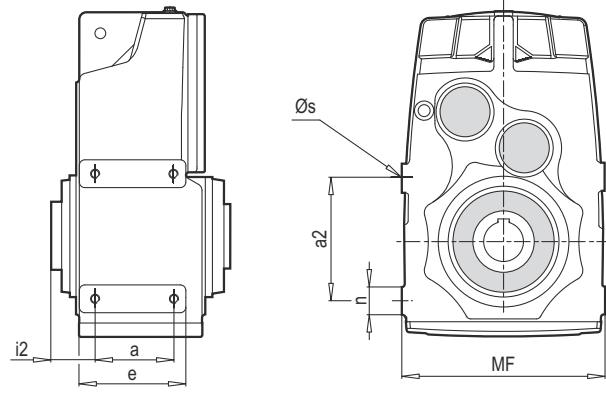

PD 92 - PD 93

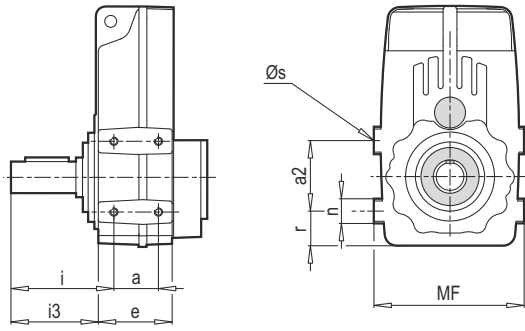

PM A02...C13

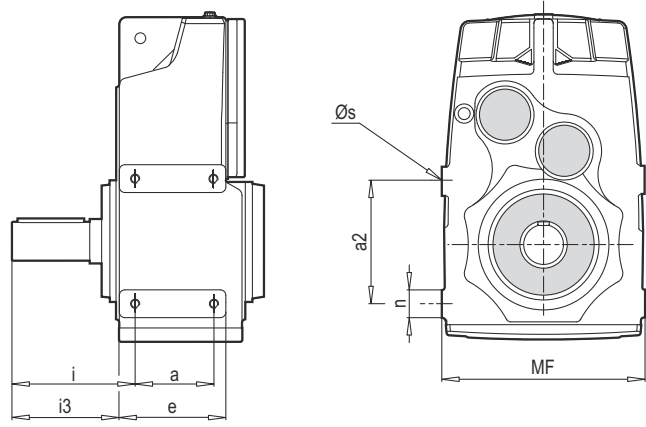

PM 92 - PM 93

Tip / Type	a	e	MF	a2	n	Øs	r	i	i2	i3
PD A02	64	78	110	50	16	M6x12	27	—	13	—
PM A02	64	78	110	50	16	M6x12	27	70	—	63
PD B02	55	74.5	150	70	25	M8x13	35	—	14	—
PM B02	55	74.5	150	70	25	M8x13	35	74	—	64
PD C13	100	126	152	70	30	M10x13	42	—	19	—
PM C13	100	126	152	70	30	M10x13	42	91	—	79
PD 92 PD 93	245	306	640	360	80	M30x45	—	—	65	—
PM 92 PM 93	245	306	640	360	80	M30x45	—	315	—	283.5
PD/PM 102-103 PD/PM 112-113 PD/PM 123	Sayfa 156...165'ye bakınız / See page 156...165									

TR

MERKEZLEME PİMİ

EN

GUIDE PINS

MERKEZLEME PİMİ ÖLÇÜ TABLOSU
DIMENSION TABLES OF CENTRING PINS

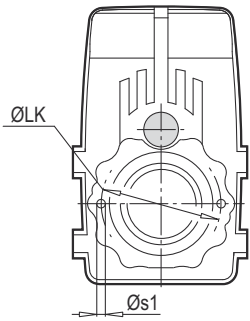

PD/PM B02
PD/PM C13

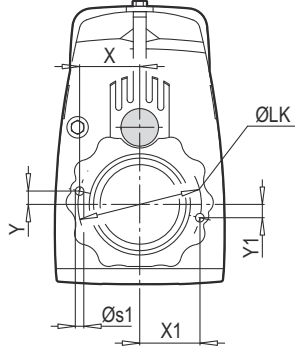

PD/PM A02
PD/PM 12 - PD/PM 53

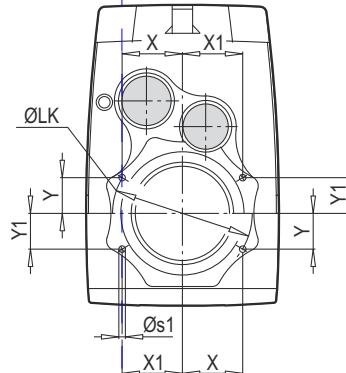

PD/PM 62 - PD/PM 83

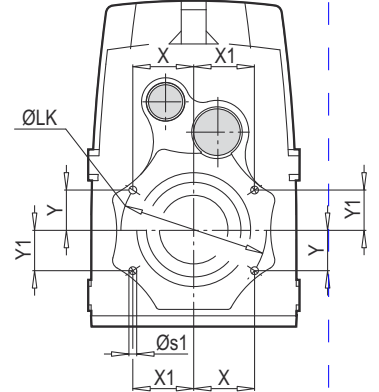

PD/PM 92 - PD/PM 123

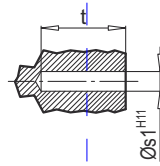

Tip / Type	Øs1 ^{H11} x t	ØLK	X	X1	Y	Y1
PD/PM A02 B14	Ø 6 X 10	85	41.05	-	11.00	-
PD/PM B02 B14	Ø 6 X 12	100	-	-	-	-
PD/PM C13 B14	Ø 8 X 12	115	-	-	-	-
PD/PM 12 B14 PD/PM 13 B14	Ø 8 X 12	115	56.15	56.15	12.45	12.45
PD/PM 22 B14 PD/PM 23 B14	Ø 8 X 12	130	62.80	62.80	16.80	16.80
PD/PM 32 B14 PD/PM 33 B14	Ø 10 X 15	165	80.55	80.55	17.85	17.85
PD/PM 42 B14 PD/PM 43 B14	Ø 12 X 20	194	93.70	93.70	25.10	25.10
PD/PM 52 B14 PD/PM 53 B14	Ø 12 X 20	215	104.95	104.95	23.25	23.25
PD/PM 62 B14 PD/PM 63 B14	Ø 12 X 20	265	111.75	111.75	71.20	71.20
PD/PM 72 B14 PD/PM 73 B14	Ø 16 X 30	300	126.50	126.50	80.60	80.60
PD/PM 82 B14 PD/PM 83 B14	Ø 16 X 30	350	147.60	147.60	94.05	94.05
PD/PM 92 B14 PD/PM 93 B14	Ø 16 X 30	400	168.70	168.70	107.45	107.45
PD/PM 102 B14 PD/PM 103 B14	Ø 25 X 35	500	176.80	204.80	176.80	143.40
PD/PM 112 B14 PD/PM 113 B14	Ø 25 X 25	500	176.80	204.80	176.80	143.40
PD/PM 123 B14	Ø 25 X 25	500	176.80	204.80	176.80	143.40

TR

KONİK SIKTIRMA

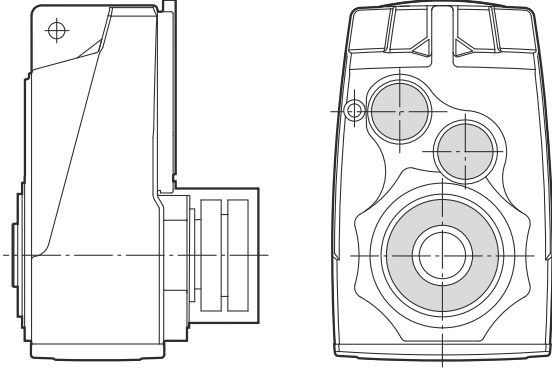

EN

SHRINK DISC

S = h6 veya f6 ile konik sıkırtmanın güvenilirliği.
S = Assurance of shrink disc (with h6 and f6 tolerance)

M_A = Civatayı sıkmak için gerekli olan tork
M_A = Screw torque for tightening

Z_S = Vida miktarı
Z_S = Amount of screw

M_{amax} = max. izin verilebilir çıkış momenti
M_{amax} = maximum allowable output moment

Konik sıkırtma, genellikle kullanıcı milinin karşı tarafına montaj edilmektedir. Şaft çapı ISO h6 veya f6'ya göre imal edilmektedir.
 (f6= Kolay montaj)

When customer shaft is installed to the gear unit, shrink disc should be mounted on opposite side of it. Customer diameter shaft should be machined according to ISO h6 or f6 tolerances.

(f6= For easy assembling)

Paralel Şaftlı Redüktör Parallel Shaft Gear Unit	Konik Sıkırtma Shrink Disc				Altıköşe Başlı Civata Hexagonal Screw DIN 931 / DIN 933* 10.9Vz		
	Tip Type	M _{amax} [Nm]	s ^{h6}	s ^{f6}	d x l	Zs	M _A [Nm]
PD B02 KS-KK	KS 30 / 40	165	5.9	5.2	M6 X 35*	8	12
PD C13 KS-KK	KS 35 / 46	370	3.8	3.4	M6 X 35*	10	12
PD 12 KS-KK	KS 30 / 40	296	3.3	2.9	M6 X 35*	8	12
PD 22 KS-KK	KS 35 / 46	563	2.6	2.2	M6 X 35*	10	12
PD 32 KS-KK	KS 40 / 55	1039	2.3	2.0	M8 X 40	8	30
PD 42 KS-KK	KS 50 / 62	2000	2.2	2.0	M8 X 40	10	30
PD 52 KS-KK	KS 60 / 76	3235	2.5	2.3	M10 X 50	10	59
PD 62 KS-KK	KS 70 / 90	6000	2.3	2.2	M12 X 70*	10	100
PD 72 KS-KK	KS 80 / 108	8300	2.5	2.4	M12 X 70*	14	100
PD 82 KS-KK	KS 100 / 128	13200	2.3	2.2	M16 X 80*	8	250
PD 92 KS-KK	KS 125 / 158	25400	2.3	2.2	M16 X 80*	12	250
PD 102 KS-KK	KS 160 / 210	37200	3.6	3.4	M20 X 100	14	490
PD 112 KS-KK	KS 180 / 230	69000	1.9	1.8	M20 X 100*	12	490
PD 122 KS-KK	KS 180 / 230	90000	4.5	4.4	M30 X 200	16	1700
Aşağıda verilen değerler güçlendirilmiş konik sıkırtma ölçüleridir The values given below is for reinforced shrink disc							
PD 72 GKS-KK	GKS 85 / 108	8300	3.90	3.65	M16 X 90	10	250
PD 82 GKS-KK	GKS 100 / 128	13200	3.57	3.35	M20 X 100	8	490
PD 92 GKS-KK	GKS 130 / 158	25400	3.89	3.71	M20 X 130	12	490
PD 112 GKS-KK	GKS 180 / 230	69000	3.69	3.57	M24 X 150	16	840

TR

KONİK SIKTIRMA

Motorlu redüktör üniteleri için mevcut konik sıkırtmalı tasarımlar.
Tüm çok kademeli motorlu redüktörleri için konik sıkırtmalı tasarım mevcuttur.

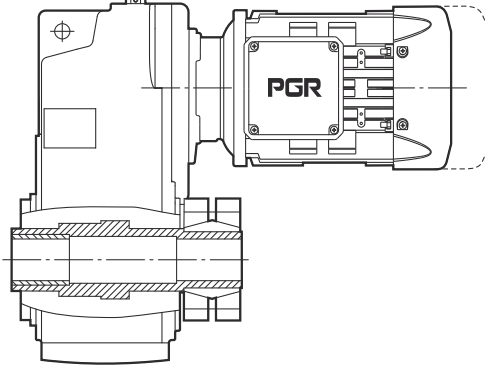

EN

SHRINK DISC

Parallel shaft geared motor with obtainable shrink disc design.
Shrink disc design is obtainable for all multi-stage parallel shaft geared motor.

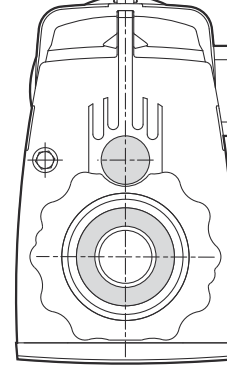

Redüktör Tipi Type of Gear Unit	63 M	71 M	80 M	90 S/L	100 L	112 M	132 S/M	160 S/M	180 M/L	200 L	225 S/M	250 M*	280 S/M/L*	315 S/M/L*
PD B02 KS	✓													
PD C13 KS	✓													
PD 12 KS	✓	✓	✓											
PD 13 KS	✓	✓												
PD 22 KS		✓	✓	✓	✓									
PD 32 KS		✓	✓	✓	✓									
PD 33 KS			✓	✓										
PD 42 KS				✓	✓	✓	✓							
PD 52 KS				✓	✓	✓	✓	✓	*					
PD 62 KS					✓	✓	✓	✓	✓					
PD 63 KS				✓	✓	✓	✓	✓	✓					
PD 72 KS							✓	✓	✓	✓	*			
PD 73 KS					✓	✓	✓	✓	✓	✓	*			
PD 82 KS							✓	✓	✓	✓	✓			
PD 83 KS					✓	✓	✓	✓	✓	✓	✓			
PD 92 KS										✓	✓	✓	✓	
PD 93 KS							✓	✓	✓	✓	✓	✓	✓	
PD 102 KS													✓	✓
PD 103 KS								✓	✓	✓	✓	✓	✓	✓
PD 112 KS													✓	✓
PD 113 KS								✓	✓	✓	✓	✓	✓	✓
PD 123 KS										✓	✓	✓	✓	✓
Aşağıda verilen bilgiler güçlendirilmiş konik sıkırtma içindir The information given below is for reinforced shrink disc.														
PD 72 GKS							✓	✓	✓					
PD 73 GKS					✓	✓	✓	✓	✓					
PD 82 GKS							✓	✓	✓	✓	*			
PD 83 GKS					✓	✓	✓	✓	✓	✓	*			
PD 92 GKS										✓	✓	✓	✓	
PD 93 GKS							✓	✓	✓	✓	✓	✓	✓	
PD 112 GKS													✓	✓
PD 113 GKS								✓	✓	✓	✓	✓	✓	✓

* İşareti talep doğrultusunda temin edilebileceğini gösterir. Lütfen PGR'ye danışınız.
* Sign shows that it could be provided on your demand. Please, consult PGR

IEC adaptörlü redüktör üniteleri için mevcut konik sıkırtmalı tasarımlar. Tüm çok kademeli IEC adaptörlü redüktörler için konik sıkırtmalı tasarım mevcuttur.

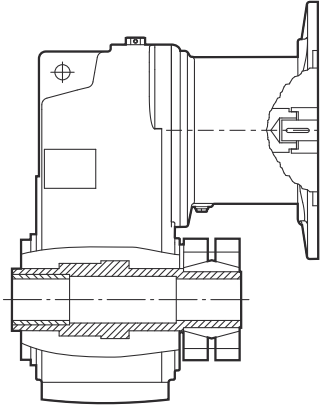

Parallel shaft gear unit with IEC adapter and obtainable shrink disc designs. Shrink disc design is obtainable for all multi-stage parallel shaft gear unit with IEC adapter.

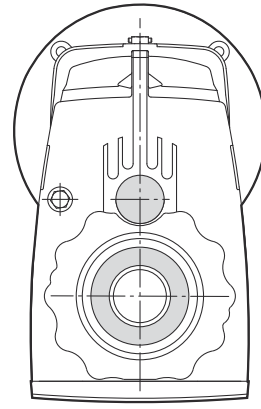

Redüktör Tipi Type of Gear Unit	IEC 63	IEC 71	IEC 80	IEC 90	IEC 100	IEC 112	IEC 132	IEC 160	IEC 180	IEC 200	IEC 225	IEC 250	IEC 280	IEC 315
PD B02 KS	✓	✓	✓	✓										
PD C13 KS	✓	✓	✓	✓										
PD 12 KS	✓	✓	✓	✓										
PD 13 KS	✓	✓												
PD 22 KS		✓	✓	✓	✓	✓								
PD 32 KS		✓	✓	✓	✓	✓	✓							
PD 33 KS	✓	✓	✓	✓										
PD 42 KS				✓	✓	✓	✓	✓						
PD 52 KS				✓	✓	✓	✓	✓	✓					
PD 62 KS					✓	✓	✓	✓	✓	✓	✓			
PD 63 KS				✓	✓	✓	✓	✓	✓					
PD 72 KS							✓	✓	✓	✓	✓			
PD 73 KS					✓	✓	✓	✓	✓	✓	✓			
PD 82 KS							✓	✓	✓	✓	✓	✓	✓	
PD 83 KS					✓	✓	✓	✓	✓	✓	✓			
PD 92 KS									✓	✓	✓	✓	✓	✓
PD 93 KS							✓	✓	✓	✓	✓	✓	✓	
PD 102 KS												✓	✓	✓
PD 103 KS								✓	✓	✓	✓	✓	✓	✓
PD 112 KS												✓	✓	✓
PD 113 KS								✓	✓	✓	✓	✓	✓	✓
PD 123 KS								✓	✓	✓	✓	✓	✓	✓
Aşağıda verilen bilgiler güçlendirilmiş konik sıkırtma içindir The information given below is for reinforced shrink disc.														
PD 72 GKS							✓	✓	✓	✓	✓			
PD 73 GKS					✓	✓	✓	✓	✓	✓	✓			
PD 82 GKS							✓	✓	✓	✓	✓			
PD 83 GKS					✓	✓	✓	✓	✓	✓	✓			
PD 92 GKS									✓	✓	✓	✓	✓	✓
PD 93 GKS							✓	✓	✓	✓	✓	✓	✓	
PD 112 GKS												✓	✓	✓
PD 113 GKS								✓	✓	✓	✓	✓	✓	✓

TR GÜÇLENDİRİLMİŞ KONİK SIKTIRMA KAPAĞI

EN COVER OF REINFORCED SHRINK DISC

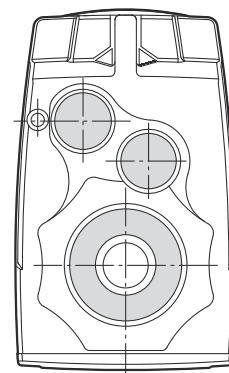
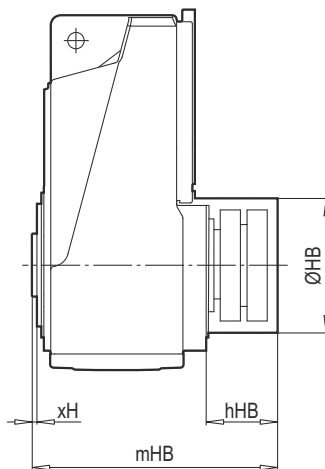
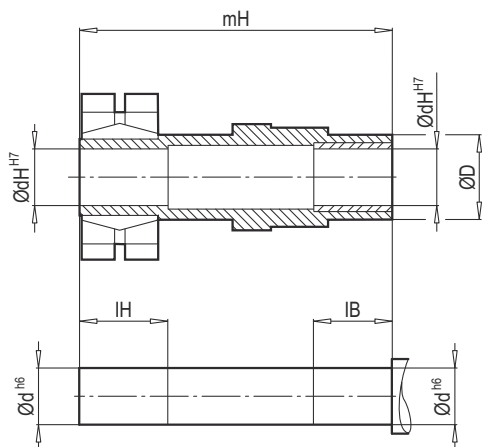

Tip / Type	ØD	ØdH H7	Ød h6	IB	IH	mH	xH	hHB	HB	mHB
PD 72 GKS - KK PD 73 GKS - KK	110	85	85	56	120	429	6.0	149	260	448
PD 82 GKS - KK PD 83 GKS - KK	130	100	100	71.5	149	510	7.0	200	308	546
PD 92 GKS - KK PD 93 GKS - KK	160	130	130	82	182	607	10.0	238	367	634
PD 112 GKS - KK PD 113 GKS - KK	240	180	180	101.5	195	755	10.0	258	458	786

TR

ŞAFT KORUMA KAPAĞI

EN

SHAFT COVER

ŞAFT KORUMA KAPAĞI ÖLÇÜ TABLOSU
 DIMENSION TABLE OF SHAFT COVER

Tip / Type	hHB	mHB
PD A02 KK PD A02 B14-KK	26	123
PD B02 KK PD B02 B14-KK	32	151
PD C13 KK PD C13 B14-KK	37	210
PD 12 KK PD 12 B14-KK PD 13 KK PD 13 B14-KK	32	152
PD 22 KK PD 22 B14-KK PD 23 KK PD 23 B14-KK	44	176
PD 32 KK PD 32 B14-KK PD 33 KK PD 33 B14-KK	46	215
PD 42 KK PD 42 B14-KK PD 43 KK PD 43 B14-KK	46	235
PD 52 KK PD 52 B14-KK PD 53 KK PD 53 B14-KK	54	278
PD 62 KK PD 62 B14-KK PD 63 KK PD 63 B14-KK	55	337
PD 72 KK PD 72 B14-KK PD 73 KK PD 73 B14-KK	55	359
PD 82 KK PD 82 B14-KK PD 83 KK PD 83 B14-KK	59	418
PD 92 KK PD 92 B14-KK PD 93 KK PD 93 B14-KK	62	482

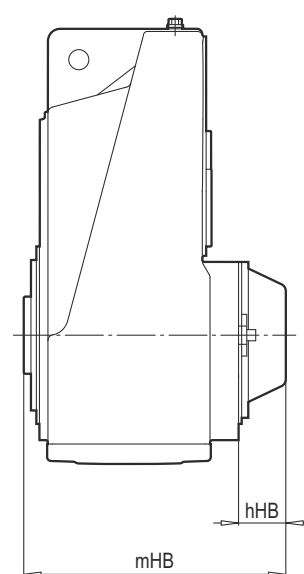
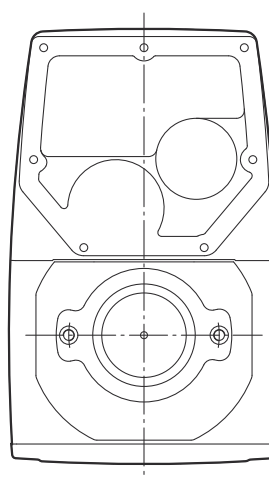

TR NORMAL VE GÜÇLENDİRİLMİŞ
LASTİK TAKOZ TASARIMI (LT/GLT)

EN NORMAL AND REINFORCED DESIGN
OF RUBBER BUFFER (LT/GLT)

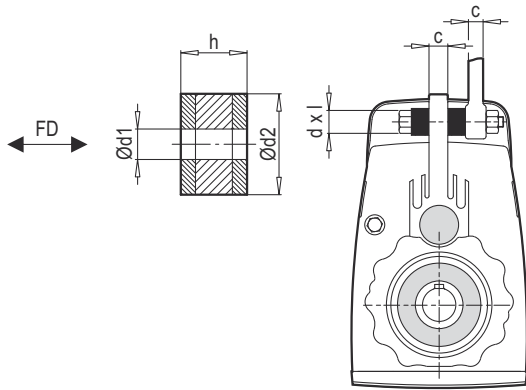

PD/PM... LT

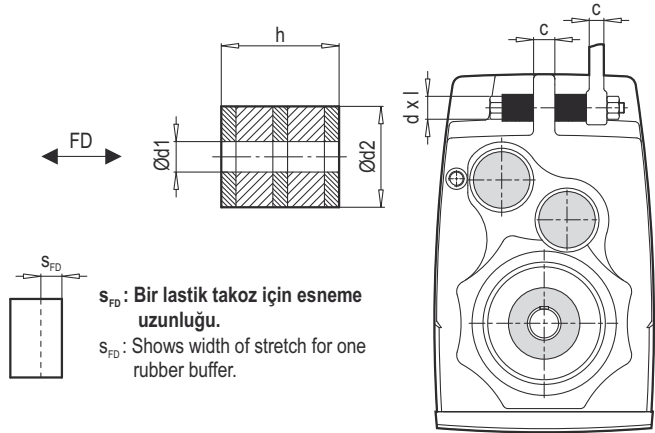

PD/PM... GLT

s_{FD} : Bir lastik takoz için esneme uzunluğu.
 s_{FD} : Shows width of stretch for one rubber buffer.

Tip / Type	Ød1	Ød2	h	c	d x l	FD [kN]	s_{FD} [mm]
PD/PM A02 LT	10.70	30	15	12	M10 x 70	0.95	1.5
PD/PM B02 LT	10.70	30	15	14	M10 x 70	1.05	1.7
PD/PM C13 LT	10.70	30	15	16	M10 x 80	2.25	3.6
PD/PM 12 LT PD/PM 13 LT	10.70	30	15	15	M10 x 80	1.80	2.8
PD/PM 22 LT PD/PM 23 LT	12.60	40	15	17	M12 x 90	2.65	1.8
PD/PM 32 LT PD/PM 33 LT	12.60	40	15	19	M12 x 90	4.15	2.9
PD/PM 42 LT PD/PM 43 LT	21.60	60	30	24	M20 x 150	7.40	7.3
PD/PM 52 LT PD/PM 53 LT	21.60	60	30	28	M20 x 150	9.50	9.4
PD/PM 62 LT PD/PM 63 LT	25.30	80	40	35	M24 x 190	16.80	9.2
PD/PM 72 LT PD/PM 73 LT	25.30	80	40	40	M24 x 200	20.80	11.4
PD/PM 82 LT PD/PM 83 LT	30.80	100	50	50	M30 x 260	28.40	16.3
PD/PM 92 LT PD/PM 93 LT	30.80	100	50	55	M30 x 260	43.50	24.9

Tip / Type	Ød1	Ød2	h	c	d x l	FD [kN]	s_{FD} [mm]
PD/PM 72 GLT PD/PM 73 GLT	25.0	85	60	40	M24 x 240	20.80	12.2
PD/PM 82 GLT PD/PM 83 GLT	31.0	110	90	50	M30 x 340	28.40	19.3
PD/PM 92 GLT PD/PM 93 GLT	31.0	140	110	55	M30 x 380	43.50	21.2
PD/PM 102 GLT PD/PM 103 GLT	31.0	140	110	80	M30 x 430	56.35	27.4
PD/PM 112 GLT PD/PM 113 GLT	49.0	180	150	90	M48 x 550	80.90	38.5
PD/PM 123 GLT	49.0	180	150	90	M48 x 550	105.50	50.2

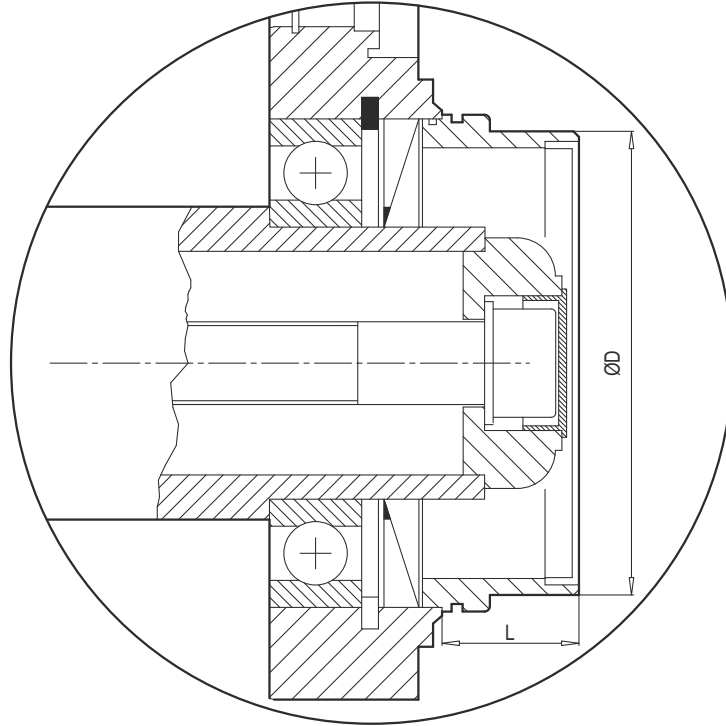

Tip / Type	ØD	L
PD 12 KK 66 PD 12 B14/KK 66	81	25
PD 22 KK 66 PD 22 B14/KK 66	57	38
PD 32 KK 66 PD 32 B14/KK 66	105	35
PD 42 KK 66 PD 42 B14/KK 66	105	34
PD 52 KK 66 PD 52 B14/KK 66	155	38
PD 62 KK 66 PD 62 B14/KK 66	189	44
PD 72 KK 66 PD 72 B14/KK 66	216	35
PD 82 KK 66 PD 82 B14/KK 66	246	50

TR PD SERİSİ İÇİN GÜÇLENDİRİLMİŞ B5 FLANŞI

Güçlendirilmiş B5 Flanşı;

PGR özellikle karıştırıcılarda kullanılan shaftların rulman mesafelerinin artması sebebiyle güçlendirilmiş B5 flanşı kullanarak shaftın rulman arası mesafelerini arttırmıştır. Bu tasarım daha uzun rulman ömrü ile birlikte yüksek radyal ve aksel kuvvetlerin absorbe edilmesini sağlar.

Özellikle oynak makaralı rulmanlar uzun karıştırıcı shaftların aksel kaçıklıklarını karşılayabilirler.

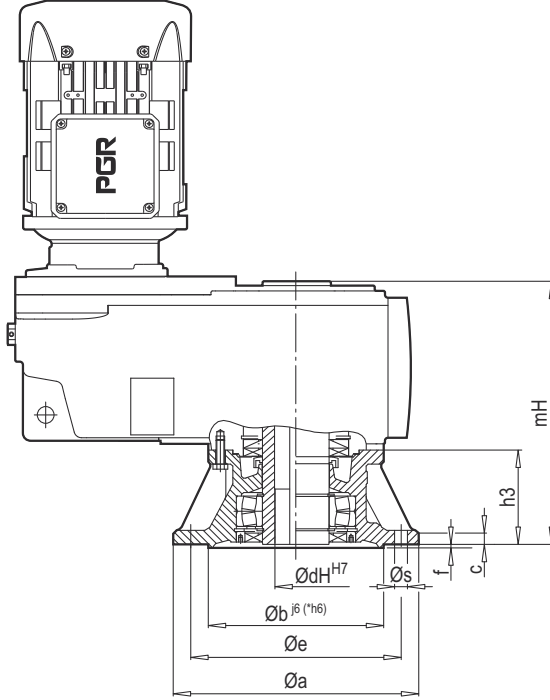

EN REINFORCED B5 FLANGE FOR AGITATOR DESIGN AT PD SERIES

Reinforced B5 Flange;

Longer shaft is used at agitator application that is caused increasing bearing distance for that reason, PGR increased bearing distance with using reinforced B5 flange at that design. Reinforced B5 flange design provides longer bearing life and could be used where high radial and axial load is effected to the gear unit.

Due to increasing bearing distance and absorbing high radial and axial load spherical roller bearing are used however it is useful for recuperating misalignment at long shaft.

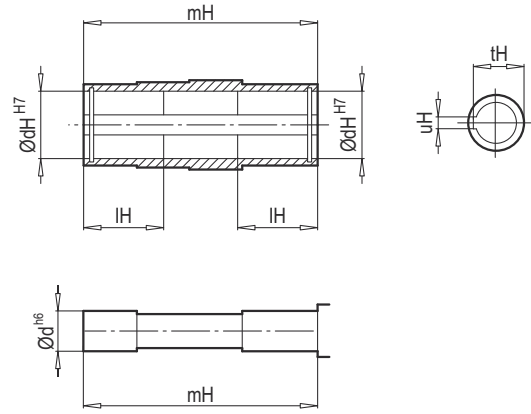

Tip / Type	a	b	c	e	f	h3	Øs	Ød ^{h6}	uH	tH	mH	ØdH ^{H7}	IH
PD 12 GB5 PD 13 GB5	200	130	12	165	3.5	75	4 x 11	30	8	33.3	180	30	40
PD 22 GB5 PD 23 GB5	250	180	16	215	4.0	86	4 x 14	35	10	38.3	208	35	50
PD 32 GB5 PD 33 GB5	300	230	20	265	4.0	85	4 x 14	40	12	43.3	246	40	58
PD 42 GB5 PD 43 GB5	300	230	20	265	4.0	113	4 x 14	50	14	53.8	290	50	65
PD 52 GB5 PD 53 GB5	350	*250	20	300	5.0	135	4 x 18	60	18	64.4	348	60	79
PD 62 GB5 PD 63 GB5	400	*300	22	350	5.0	166	4 x 18	70	20	74.9	437	70	120
PD 72 GB5 PD 73 GB5	450	*350	24	400	5.0	184	8 x 18	80	22	85.4	477	80	126
PD 82 GB5 PD 83 GB5	550	*450	28	500	5.0	210	8 x 18	100	28	106.4	556	100	154
PD 92 GB5 PD 93 GB5	660	*550	32	600	6.0	262	8 x 22	120	32	127.4	668	120	186

TR PM SERİSİ İÇİN GÜÇLENDİRİLMİŞ B5 FLANŞI

EN REINFORCED B5 FLANGE FOR AGITATOR DESIGN AT PM SERIES

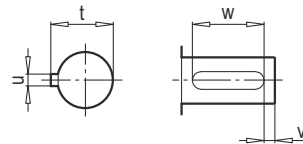
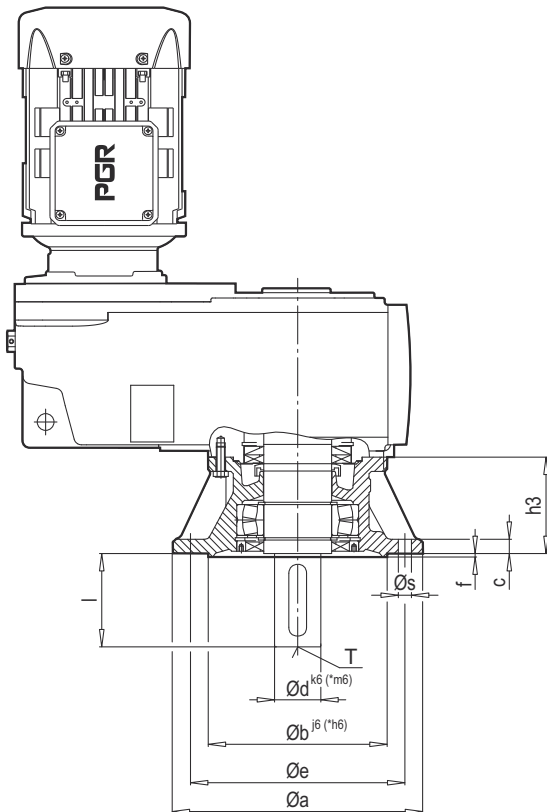

Tip / Type	a	b	c	e	f	h3	Øs	Ød	l	t	u	v	w	T
PM 12 GB5 PM 13 GB5	200	130	12	165	3.5	75	4 x 11	30	60	33.0	8	5	50	M10
PM 22 GB5 PM 23 GB5	250	180	16	215	4.0	86	4 x 14	35	70	38.0	10	5	60	M12
PM 32 GB5 PM 33 GB5	300	230	20	265	4.0	85	4 x 14	45	90	48.5	14	5	80	M16
PM 42 GB5 PM 43 GB5	300	230	20	265	4.0	113	4 x 14	*55	110	59.0	16	10	90	M20
PM 52 GB5 PM 53 GB5	350	*250	20	300	5.0	135	4 x 18	*65	130	69.0	18	15	100	M20
PM 62 GB5 PM 63 GB5	400	*300	22	350	5.0	166	4 x 18	*75	140	79.5	20	7.5	125	M20
PM 72 GB5 PM 73 GB5	450	*350	24	400	5.0	184	8 x 18	*90	170	95.0	25	15	140	M24
PM 82 GB5 PM 83 GB5	550	*450	28	500	5.0	210	8 x 18	*110	210	116.0	28	15	180	M24
PM 92 GB5 PM 93 GB5	660	*550	32	600	6.0	262	8 x 22	*140	250	148.0	36	25	200	M24
PM 102 GB5 PM 103 GB5	660	*550	35	600	8.0	302	8 x 26	*160	300	169.0	40	25	250	M24
PM 112 GB5 PM 113 GB5	660	*550	35	600	8.0	302	8 x 26	*180	300	190.0	45	25	250	M24
PM 123 GB5	660	*550	35	600	8.0	302	8 x 26	*180	300	190.0	45	25	250	M24

TR KONİK SIKTIRMALI GÜÇLENDİRİLMİŞ B5 FLANŞLI

EN WITH REINFORCED B5 FLANGE AND SHRINK DISC

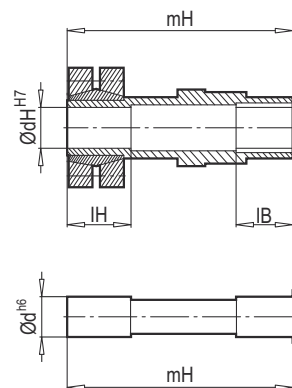
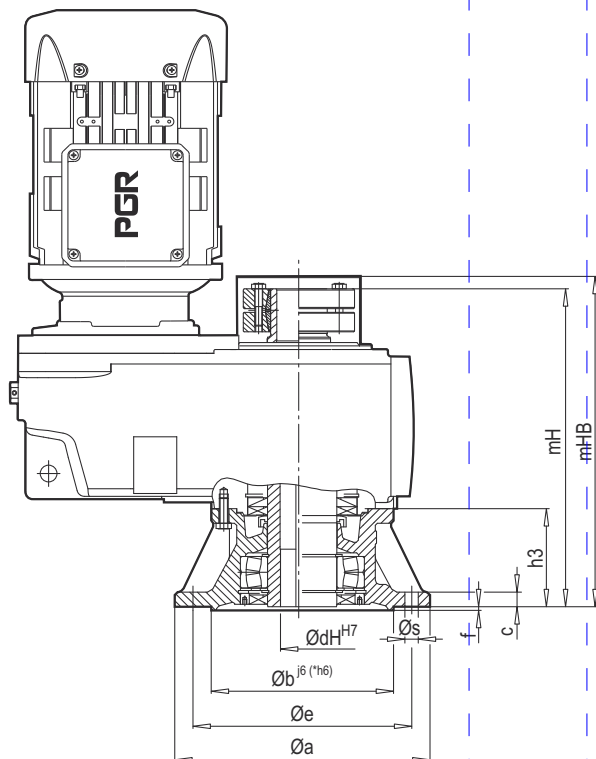

Tip / Type	a	b	c	e	f	h3	Øs	ØdH ^{H7}	mH	mHB	IB	IH	Ød ^{H6}
PD 12 KS-GB5 PD 13 KS-GB5	200	130	12	165	3.5	75	4 X 11	30	220	233	31	40	30
PD 22 KS-GB5	250	180	16	215	4.0	86	4 X 14	35	264	284	41	45	35
PD 32 KS-GB5 PD 33 KS-GB5	300	230	20	265	4.0	85	4 X 14	40	297	317	41	55	40
PD 42 KS-GB5	300	230	20	265	4.0	113	4 X 14	50	356	329	51	55	50
PD 52 KS-GB5	350	*250	20	300	5.0	135	4 X 18	60	413	437	60	70	60
PD 62 KS-GB5 PD 63 KS-GB5	400	*300	22	350	5.0	166	4 X 18	70	517	540	71	85	70
PD 72 KS-GB5 PD 73 KS-GB5	450	*350	24	400	5.0	184	4 X 18	80	562	582	81	90	80
PD 82 KS-GB5 PD 83 KS-GB5	550	*450	28	500	5.0	210	8 X 18	100	645	672	71	95	100
PD 92 KS-GB5 PD 93 KS-GB5	660	*550	32	600	6.0	262	8 X 22	125	773	797	82	110	125
PD 102 KS-GB5 PD 103 KS-GB5	660	*550	35	600	8.0	302	8 X 26	160	944	970	122	130	160
PD 112 KS-GB5 PD 113 KS-GB5	660	*550	35	600	8.0	302	8 X 26	180	958	1000	101	110	180
PD 123 KS-GB5	660	*550	35	600	8.0	302	8 X 26	180	1129	1169	101	269	180

TR

SU SOĞUTMALI

Entegre edilmiş bir ısı dönüştürücüsü, helisel konik dişli üniteleri ve paralel dişli ünitelerinde isteğe bağlı olarak mevcuttur. Dişli ünitesini soğutan soğutma suyu ısı dönüştürücüsü içinden akar. PGR, redüktör sıcaklığının ve soğutma suyunun akışının izlenmesini önerir. Soğutma bobini, yağ odası içinde bulunmamaktadır. Soğutma suyu patlama olabilecek çalışma ortamlarında çalışması uygundur. Düşük sıcaklıklarda, ısı dönüştürücüsü, dişli ünitesine ısı sağlayabilir.

EN

WATER COOLING

For cooling gear unit, conjugate heat exchanger is optionally available. (This design exist for helical - bevel and parallel shaft gear units.) PGR suggests to check cooling water flow and temperature of gear unit because coil of heat exchanger is on the cover of gear unit. Heat transfer from oil or gear unit to cooling water should be monitored. This design could be used in explosive areas. Heat exchanger might supply heat to the gear unit in low temperature.

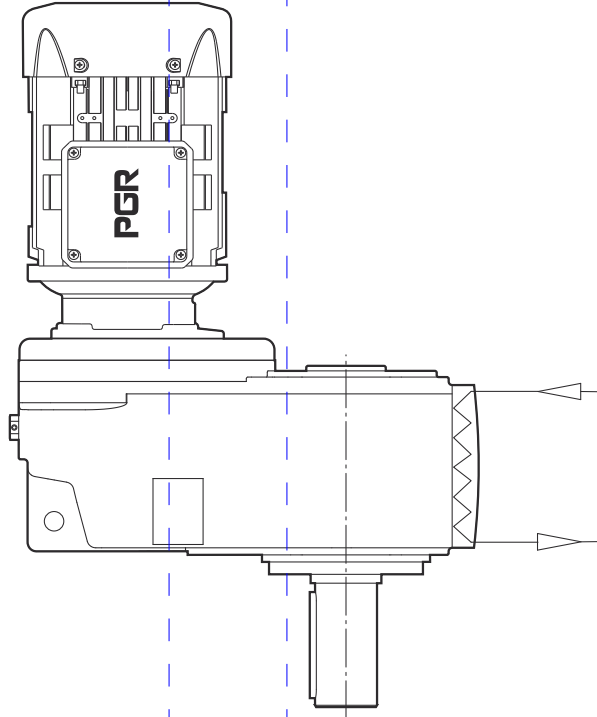

Su soğutma ünitesinin kullanılabileceği montaj pozisyonları

The following table shows the suitability of water cooling for the related mounting positions

Tip / Type	Montaj Pozisyonları / Mounting Positions					
	M1	M2	M3	M4	M5	M6
PD/PM 62 - PD/PM 63	✓	✓	—	✓	✓	✓
PD/PM 72 - PD/PM 73	✓	✓	—	✓	✓	✓
PD/PM 82 - PD/PM 83	✓	✓	—	✓	✓	✓
PD/PM 92 - PD/PM 93	✓	✓	—	✓	✓	✓
PD/PM 102 - PD/PM 103	✓	✓	—	✓	✓	✓
PD/PM 112 - PD/PM 113	✓	✓	—	✓	✓	✓
PD/PM 123	✓	✓	—	✓	✓	✓

TR

M4 MONTAJ POZİSYONU İÇİN İLAVE YAĞ HACMİ VE YAĞ TANKI

EN

ADDITIONAL LUBRICANT VOLUME AND OIL TANK FOR MOUNTING POSITION M4

İLAVE YAĞ HACMİ

ADDITIONAL LUBRICANT VOLUME

Tip Type	Boyut Size	Ø D [mm]	H [mm]	[kg]
PD\PM 42 - PD\PM 43	I	100	180	6
PD\PM 52 - PD\PM 53				
PD\PM 63	II	150	300	7
PD\PM 62				
PD\PM 72 - PD\PM 73	III	180	300	8
PD\PM 82 - PD\PM 83				

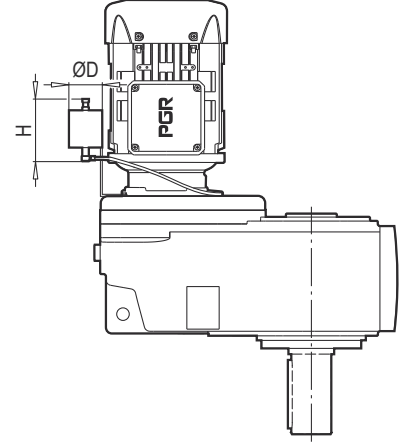

PD\PM 42...83

Bu ilave yağ hacim ünitesinin kullanılması, dikey montaj pozisyonlarında (M4) ve kötü çalışma şartları altında bile havalandırma tapasından yağ sızmasını önler. Dikey çalışma ortamlarında redüktör içindeki yağ köpüklenme yapabilir ve bu ünite ilave bir hacim sağlar.

İlave yağ hacim ünitesi, tahvil oranı 20' den küçük paralel şaftlı dişli üniteleri PD\PM 42...83 arasındaki gövdelerin dikey montaj pozisyonu uygulamalarında kullanımı önerilir.

Additional lubricant volume unit is used to prevent oil leakage from venting plug when gear unit is mounted with M4 mounting position. It is important because at vertical mounting position oil could be foamed.

PGR suggest that additional lubrication volume units should be used when gear reduction is less than 20 and for polat hollow or solid shaft gear unit series from PD\PM 42 to PD\PM 83 when M4 vertical mounting position is applied.

YAĞ TANKI

Yağ tankları ek havalandırma tüpü içerdiği için ilave yağ hacmi ünitesine göre daha büyüktür. Yağ tankındaki yağ seviyesi sürekli olarak kontrol edilmelidir. PGR PD\PM 92...123 arasındaki büyük gövdelerin M4 dikey montaj pozisyonlarında yağ tankının kullanımı önerir. PGR M4 montaj pozisyonunda yağ tankı kullanılmayan uygulamalarda oluşabilecek problemlerden sorumlu değildir.

34 - 39

OIL TANK

If we compare oil tank and additional lubricant volume, oil tank has large volume than additional lubricant volume because there are two tubes which one of them is vent tube and the other one is oil tube. Oil level must be checked all the time. PGR suggests that , oil tanks should be used at M4 vertical mounting positions for large cases of parallel shaft gear units which are from PD\PM 92 to PD\PM 123. PGR is not responsible for any problem that may occur while oil tank is not used at M4 vertical mounting position for large cases of parallel shaft gear unit.

34 - 39

Tip Type	Boyut Size	Ø D [mm]	H [mm]
PD\PM 92 - PD\PM 93	A	185	390
PD\PM 102 - PD\PM 103			
PD\PM 112 - PD\PM 113	B	320	390
PD\PM 123			

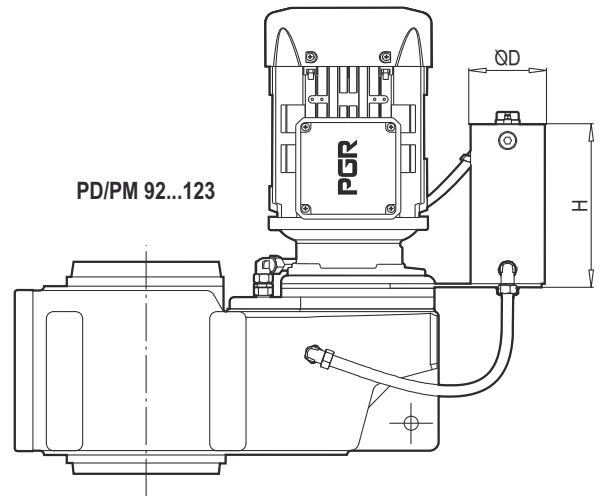

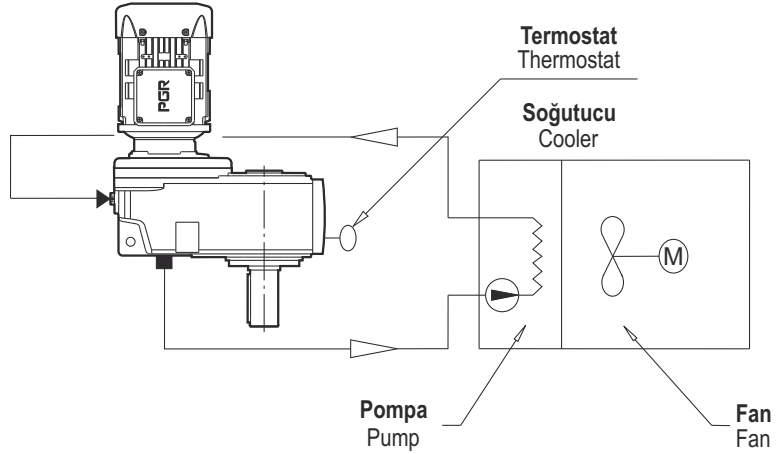

■ Çıkış = Emme hattı

▼ Yağ seviyesi = Basınç hattı

Dişli ünitesi yağı, bir pompa tarafından çekilir ve bir ısı dönüştürücüsü boyunca akar. Yağ, fan tarafından yaratılan bir hava akımı ile soğutulur. Yağ, ısı dönüştürücünün dışına taşınır ve tekrar haznesine geri gönderilir. Sıcaklık bir termostat tarafından kontrol edilir. PGR, sıcaklığın izlenmesini önerir.

■ Output = Suction line

▼ Oil level = Pressure line

Picture which is above on this page shows cycle of the cooling unit. There is a thermostat on the gear unit for checking oil temperature. Oil flows from suction line to pressure line which is provided by a pump. In this way, oil temperature is cooled down by a fan which is supplying air flow of oil. Then, oil flows to the house of gear unit.

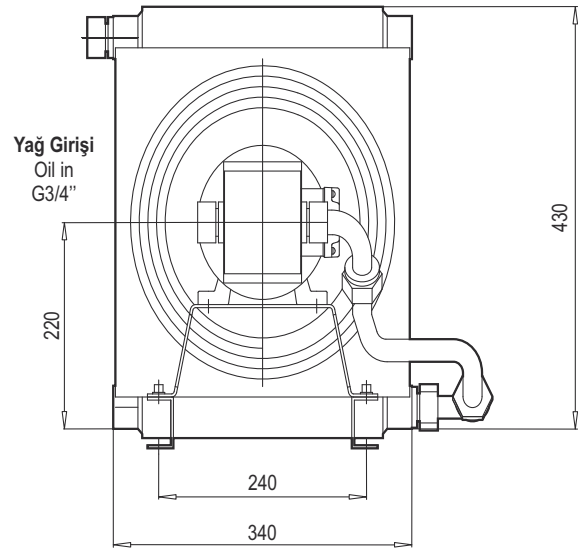
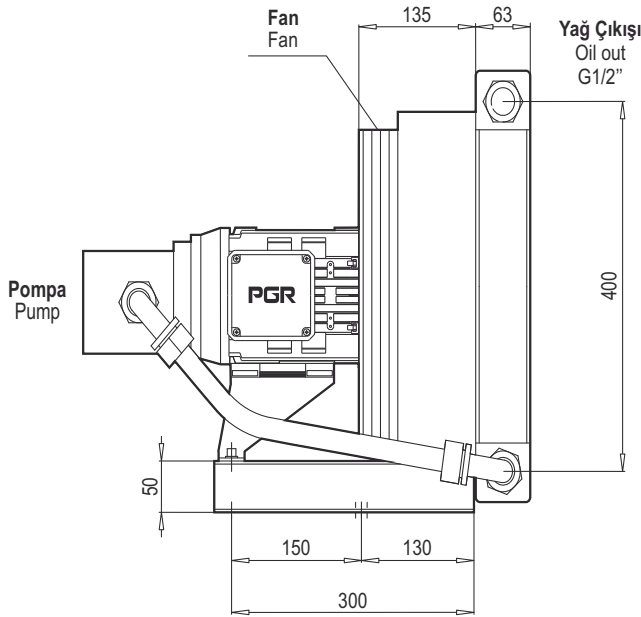

* Potansiyel patlayıcı atmosferli alanlar için uygun değildir.

Design

Soğutucu	: TFS/A 8,5-400-F-03-11
Düşürme	: Dış 1/2" - iç 3/4"
Motorlar	: Spannung 3x400 V
Çıkış gücü	: 0,55 kW
Hız	: 1350 d/dk
Koruma sınıfı	: IP 55
Yalıtım sınıfı	: F
Sıcaklık sınıfı	: B

Aşağıdaki özelliklerde mevcuttur:
- Özel voltaj 60 HZ - Özel motor

Ağırlık : 32 kg

* Not suited for areas with potentially explosive atmospheres

Design

Cooler	: TFS/A 8,5-400-F-03-11
Reduction	: Out 1/2" / in 3/4"
Motors	: Spannung 3x400 V
Output	: 0,55 kW
Speed	: 1350 rpm
Protection Class	: IP 55
Insulation Class	: F
Temperature Class	: B

Available with:
- Special voltage 60 HZ - Special motor

Weight : 32 kg

TR

MEKANİK KEÇE

EN

MECHANICAL SEAL

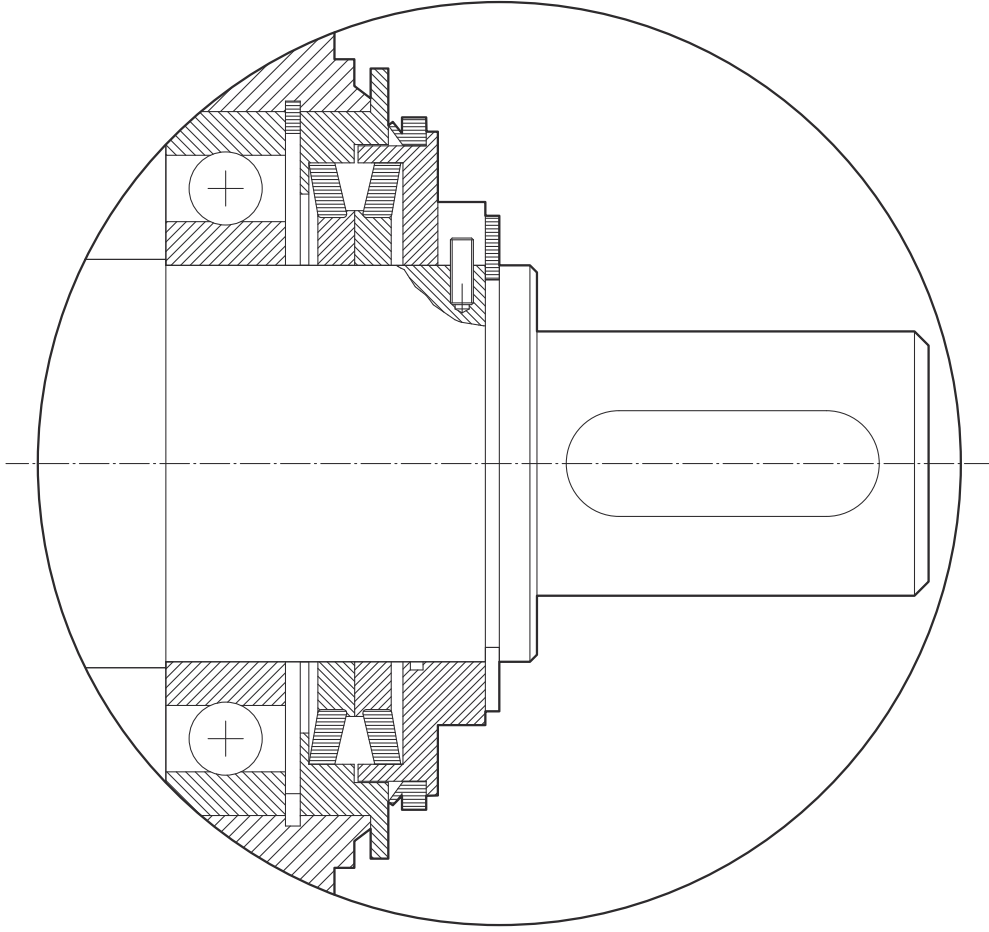

MEKANİK KEÇE

Özellikle aşırı çalışmalarda ve çok kötü çalışma koşullarında uygundur. Daldırmalı veya sulu çalışma ortamlarından etkilenmemektedir. Bu keçe tipi dış çevre koşullarından kesin koruma sağlar.

MECHANICAL SEAL

Seals are important to prevent oil leakage and for protection in bad environments. In hazardous environment and extreme operation conditions sealing must be considered. For that reason mechanical seals are applicable for using at hazardous environment, submerged operation.

TR

ÇEKİRME KİTİ
Çektirme Kiti

Çektirme kiti, şaft montajlı dişli ünitelerinde opsiyonel olarak bulunur.

Kullanım Şartları:

- Kullanılacak müşteri milinin merkezinde DIN 332/2 standartlarında bir delik açılmalıdır.
- Müşterinin mili, faturalı yada faturasız olsa da, çektirme kiti ile sabitlenebilmektedir.
- I'deki montaj kullanıldığında, müşteri mili, redüktör şaftı içinde bulunan segman ile tutturulur. (Parça A)
- II'deki montaj kullanıldığında, müşteri milinin üzerinde bulunan fatura kullanılarak doğrudan redüktör şaftı üzerine tutturulur. (Parça B)

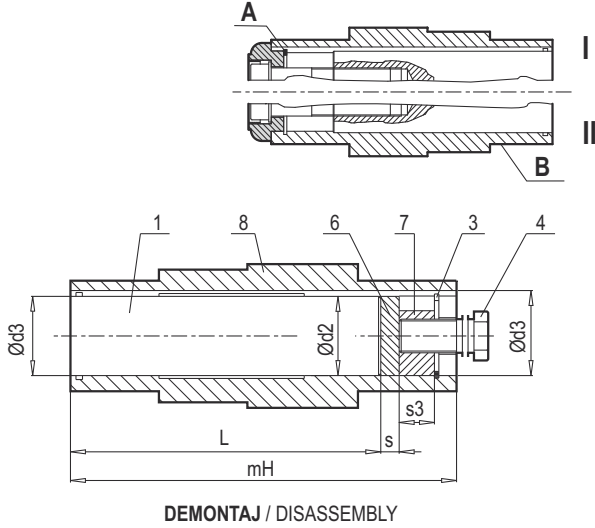

L= max. kullanıcı şaft boyu
L= maximum length of the solid shaft

- 1) Müşteri mili
- 2) Rondela DIN 127
- 3) * İç Segman DIN 472
- 4) * Çektirme civatası
- 5) Alyan başlı civata DIN 912
- 6) * Yaylı rondela
- 7) * Somun
- 8) Redüktör şaftı
- 9) Çektirme rondelası

*Dikkat, yıldızlı ürünler PGR tarafından temin edilmez.

DEMONTAJ:

- 1) Alyanbaşı civata sökülmelidir. (poz.5)
- 2) Çektirme rondelası çıkartılmalıdır. (poz.9)
- 3) Yaylı rondela takılmalıdır. (poz.6)
- 4) Somun yerleştirilmelidir. (poz.7)
- 5) Segman takılmalıdır. (poz.3)
- 6) Çektirme civatasını gevşeterek müşteri mili şafttan ayrılmalıdır. (poz.4)

KOŞULLAR:

Kullanıcı mili DIN 332/2' e göre merkezine dış açılmış delik gerekmektedir. Müşteri mili "L" uzunluğunu geçmemelidir aksi halde çektirme işlemi uygulanamaz. (poz. 5,6,7)

MONTAJ:

- 1) Müşteri mili, redüktör şaftının içerisine yerleştirilmelidir. (poz.8)
- 2) Çektirme rondelası redüktör şaftının içine yerleştirilmelidir.
- 3) Çektirme rondelası ile alyan başlı civata ve rondela sabitlenmelidir. (poz.2-5)

EN

PULLER KIT
Puller Kit

The puller kit is optionally available on shaft mounted gear units.

Using conditions:

- The centre hole must be DIN 332/2 for customer solid shaft.
- The customer shaft can be fixed with the puller kit (with shoulder or without shoulder)
- When the assembly in Fig. I is used, the customer shaft is fasten by the circlip in the gear unit shaft.(Track A)
- When the assembly in Fig. II is used,It is fasten directly to the gearbox shaft using the invoice on the customer shaft.

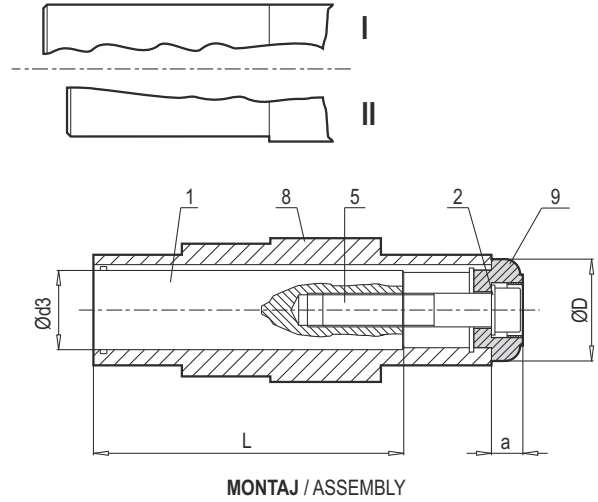

- 1) Customer's shaft
- 2) Washer DIN 127
- 3) * Circlip DIN 472
- 4) * Puller screw
- 5) Socket head screw DIN 912
- 6) * Thrust washer
- 7) * Nut
- 8) Hollow shaft
- 9) Puller washer

*Star signs are shown this item are not provided by PGR

DISASSEMBLING:

- 1) Loosen the socket head screw (5)
- 2) Remove puller washer (9)
- 3) Install spring washer (6)
- 4) Install nut(7)
- 5) Install circlip (3)
- 6) Remove solid shaft from hollow shaft with using puller screw (4)

CONDITIONS

The user shaft must be threaded to the center according to DIN 332/2. The customer shaft must not exceed the "L" length, otherwise the puller cannot be applied. (pos. 5,6,7)

ASSEMBLING:

- 1) The customer shaft must be mounted inside the gear units shaft. (8)
- 2) The puller washer must be mounted inside the gear units shaft. (9)
- 3) The bolt and washer must be fixed with the puller washer. (2-5)

TR

ÇEKTİRME ÖLÇÜ TABLOSU

EN

DIMENSION TABLE OF FIXING ELEMENT

Tip / Type	1 L	2	3	4	5	6		7		8 d x mH	9		
						d2	s	d3	s3		a	D	
PD A02 Ç	79	A10	125 x 1.5	M10	M10 X 45	24.9	3	24.9	12	M10	25 X 100	20	38
PD B02 Ç	100	A10	130 x 1.5	M12	M10 X 45	29.9	3	29.9	12	M12	30 X 122	20	40
PD C13 Ç	149	A12	135 x 1.75	M16	M12 X 55	34.9	3	34.9	16	M16	35 X 176	24.5	45
PD 12 Ç	100	A10	130 x 1.2	M12	M10 X 45	29.9	3	29.9	12	M12	30 X 122	20	40
PD 22 Ç	110	A12	135 x 1.5	M16	M12 X 55	34.9	3	34.9	16	M16	35 X 139	24.5	45
PD 32 Ç	140	A16	140 x 1.75	M16	M16 X 70	39.9	4	39.9	16	M16	40 X 174	24.7	55
PD 42 Ç	160	A16	150 x 2.0	M20	M16 X 70	49.9	4	49.9	20	M20	50 X 195	25.7	65
PD 52 Ç	185	A20	160 x 2.0	M24	M20 X 90	59.9	5	59.9	24	M24	60 X 230	30	75
PD 62 Ç	245	A20	170 x 2.5	M24	M20 X 90	69.9	5	69.9	24	M24	70 X 290	31.3	95
PD 72 Ç	250	A20	180 x 2.5	M30	M20 X 100	79.9	8	79.9	30	M30	80 X 310	31	102
PD 82 Ç	310	A24	1100 x 3.0	M30	M24 X 110	99.9	8	99.9	30	M30	100 X 366	36.5	120
PD 92 Ç	370	A24	1120 x 4.0	M36	M24 X 110	119.9	10	119.9	32	M36	120 X 430	36.5	150

Tabloda belirtilen numaralar Sayfa 64'te açıklanmaktadır.

The numbers which are specified at table are explained on Page 64.

Motor Platformu Ölçüleri
Motor Platform Dimensions

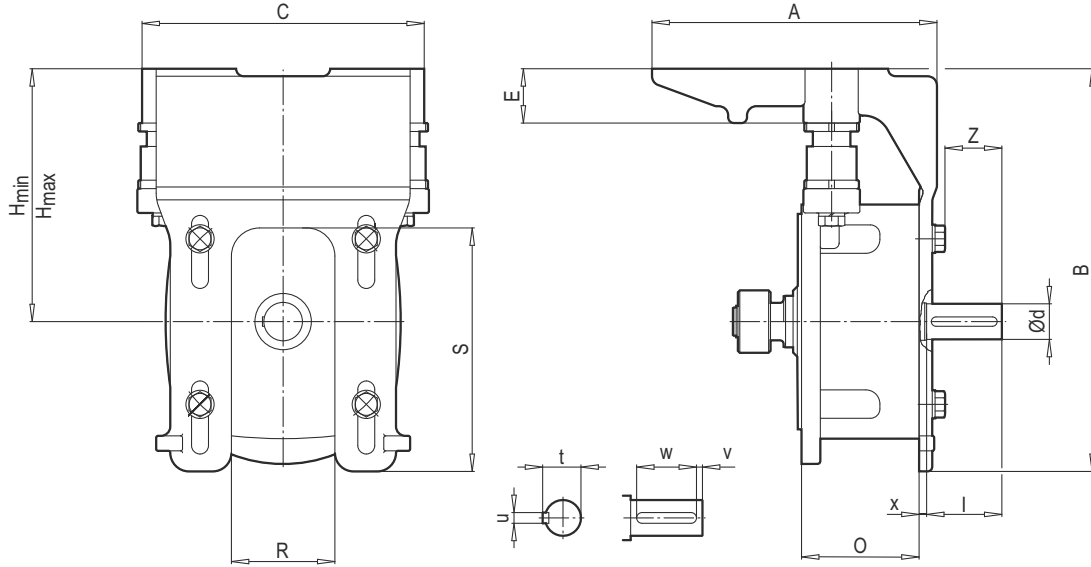

Tip Type	Bağlantı boyutları ve platform ölçüleri Connection and platform dimensions										Mil Ölçüleri Shaft size				Flanş Flange
	A	B	C	E	R	S	H min	H max	Z	O	Ød l	t u	v w	x	
MK I 63 M - 100 L	224	253	206	45	60	140	153	173	41	121.5	24 50	27 8	5 40	8	160 S
MK II 80 M - 112 M	238	320	252	50	66	145	199	224	48	115.5	28 60	31 8	5 50	9	250 S
MK III-A 90 S - 132 M	305	430	302	58	110	260	254	286	61	127	38 80	41 10	5 70	8	300 S
MK III-B 90 S - 132 M	305	430	302	58	110	260	254	286	91	172	42 110	45 12	10 90	8	Ø250
MK IV 112 M - 200 L	478	530	402	75	130	315	315	355	116	254	65 140	69 18	15 110	8	Ø350
MK V 200 L - 250 M	664	690	572	105	382	369	465	515	119	247	65 140	69 18	15 110	12	Ø450

Motor Platform Montajı

Motor platform tasarımı PGR monoblok dişli ünitesi serilerinin tüm montaj pozisyonlarında kullanılabilir. 5 adet motor platformu boyutu tüm motor-redüktör kombinasyonlarını kapsar. Çok kademeli redüktörleri de karşılayan ayrı ayrı redüktörler için seçim tablolarından motor platformları bakılabilir.

- * Her montaj pozisyonu için kullanılabilir.
- * Optimum kayış gerilimi için kolayca yönlendirilebilen yükseklik ayarlaması yapılabilir.
- * Sabitleme elemanlarında dahil olmak üzere korozyona karşı dirençlidir.
- * Hafif, vibrasyonu absorbe eden alüminyum yapı mevcuttur.
- * Birçok motor boyutu için kullanım kolaylığı sağlar.
- * Tabloya göre "i" oranının 1'e eşit olduğu durumlar için önerilir.
- * Her yöne 90°'ye kadar eksen etrafında dönebilme özelliğine sahiptir.

Assembling Motor Platform

Motor platform design could be used at all PGR monoblock gear unit series for all mounting positions. There are 5 motor platform designs. These platforms are provided with the possibility of being used with all motor-gear unit series. Motor platform type, dimension and suitable belt types could be followed from table which is shown on page 67-68, on the other hand this table is valid for multi stage gear units.

- * It could be used for all mounting positions.
- * It could be adjusted for optimum belt-tension and height easily.
- * It has high corrosion resistance even fixing elements have this property.
- * Aluminium structure provide vibration absorbing and light weight.
- * It could be used with all motor type.
- * It is recommended to be used when "i" ratio equals to one.
- * It could be adjusted to all directions up to 90°

TR

MOTOR PLATFORMU

EN

INSTALLATION OF MOTOR PLATFORM

Tip Type	PD/PM 12	PD/PM 22 PD/PM 32	PD/PM 42 PD/PM 52 PD/PM 63	PD/PM 62 PD/PM 72 PD/PM 73 PD/PM 83 PD/PM 93	PD/PM 82 PD/PM 92 PD/PM 103	PD/PM 93	PD/PM 113 PD/PM 123
Motor	W III	W II	W III	W III W IV	W IV W V	W V	W IV
63 M	MK I						
71 M	MK I						
80 M	MK I	MK II					
90 S 90 L	MK I	MK II	MK III - A	MK III - B			
100 L	MK I	MK II	MK III - A	MK III - B			
112 M		MK II	MK III - A	MK III - B	MK IV		
132 S 132 M			MK III - A	MK III - B	MK IV		
160 M 160 L				MK IV	MK IV		
180 M 180 L				MK IV	MK IV		
200 L				MK IV	MK IV		MK V
225 S 225 M					MK V	MK V	MK V
250 M					MK V	MK V	MK V

Seçim Örneği:

Çıkış gücü ve hızına göre gerekli olan dişli ünitesinin temel tipini ve gerekli çıkış gücü veya çıkış dönüş hızına dayanan çıkış gücü ve dişli oranını saptayınız.

Örnek :

0.25 kW , 13.3 d/dk i = 109.45
PD 12 - 71 M

Bu esas dişli ünitesi tipi için, motor platformu MK I tayin edildiğini tablodan (yukarıya bakınız) saptayınız.
Bu nedenle, tam tip tanımı **PD 12 - MK I - 71**'dir.

MK I için, tablodan (sayfa 68) bant makarası ve bant tipi ile ilgili daha fazla bilgi alabilirsiniz.

Esas boyutlar, tabloda gösterilmiştir.

Example:

Motor platform assignment could be explained in one example hence, according to selecting gear unit reduction ratio, output speed and motor power is determined.

For instance ;

0.25 kW , 13.3 min⁻¹ , i = 109.45
PD 12 - 71 M

According to the above table type of gear unit (column) and motor type (row) are intersected. Hence, from this motor bracket MK I dimension should be used. Full designation is **PD 12 - MK I - 71**.

The following page shows more detail about belt pulley and type of belt (see page 68).

You can see dimension of belt length with motor platform assignment.

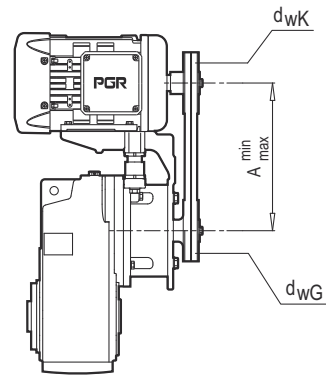
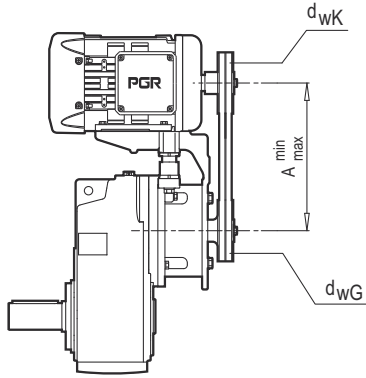

	Motor	Çıkış Output (kW)	Ayar aralığı Adjustment range		Kayış uzunluğu Belt length	Mil merkezi uzaklığı Shaft centre distance A	Kayış sayısı Number of belts	
			Amin	Amax				
MK I Kayış Tipi SPZ Belt type SPZ	63 M/4A	0.12	216	236	(dwg = 80) (i = 1) Lw 697	223	1	
	63 M/4B	0.18	216	236		697	223	1
	71 M/4A	0.25	224	244		710	229	1
	71 M/4B	0.37	224	244		710	229	1
	80 M/4A	0.55	233	253		737	243	1
	80 M/4B	0.75	233	253		737	243	1
	90 S/4A	1.10	243	263		750	249	1
	90 L/4A	1.50	243	263		750	249	2
	100 L/4A	2.20	253	273		772	260	2
	100 L/4B	3.00	253	273		772	260	3
MK II Kayış Tipi XPZ Belt type XPZ	80 M/4A	0.55	279	304	(dwg = 112) (i = 1) Lw 930	289	1	
	80 M/4B	0.75	279	304		930	289	1
	90 S/4A	1.10	289	314		950	299	1
	90 L/4A	1.50	289	314		950	299	1
	100 L/4A	2.20	299	324		980	314	1
	100 L/4B	3.00	299	324		980	314	2
	112 M/4B	4.00	311	336		1000	324	2
MK III Kayış Tipi SPZ Belt type SPZ	90 S/4A	1.10	344	376	(dwg = 160) (i = 1) Lw 1222	360	1	
	90 L/4B	1.50	344	376		1222	360	1
	100 L/4A	2.20	354	386		1250	374	1
	100 L/4B	3.00	354	386		1250	374	1
	112 M/4B	4.00	366	398		1262	380	2
	132 S/4C	5.50	386	418		1312	405	2
	132 M/4B	7.50	386	418		1312	405	3
	132 M/4	9.20	386	418		1312	405	3
MK IV Kayış Tipi XPA Belt type XPA	112 M/4B	4.00	427	467	(dwg = 200) (i = 1) Lw 1500	436	1	
	132 S/4C	5.50	447	487		1550	461	1
	132 M/4B	7.50	447	487		1550	461	2
	132 M/4	9.20	447	487		1550	461	2
	160 M/4B	11.0	475	515		1600	486	2
	160 L/4A	15.0	475	515		1600	486	3
	180 M/4B	18.5	495	535		1650	511	3
	180 L/4B	22.0	495	535		1650	511	4
	200 L/4C	30.0	515	555		1700	536	4
MKV Kayış Tipi SPA Belt type SPA	200 L/4C	30.0	665	715	(dwg = 250) (i = 1) Lw 2182	698	4	
	225 S/4A	37.0	690	740		2207	710	4
	225 M/4C	45.0	690	740		2207	710	5
MK V Kayış Tipi SPB Belt type SPB	250 M/4C	55.0	715	765	(dwg = 250) (i = 1) Lw 2240	727	4	

Motorlu Seçim Tabloları

Selection Tables of
Geared motors

PD/PM A02...C13

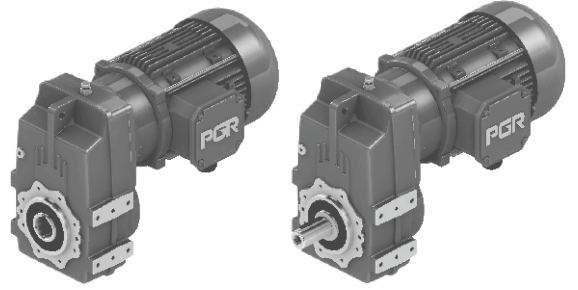

PD/PM 12...52
PD/PM 13...53

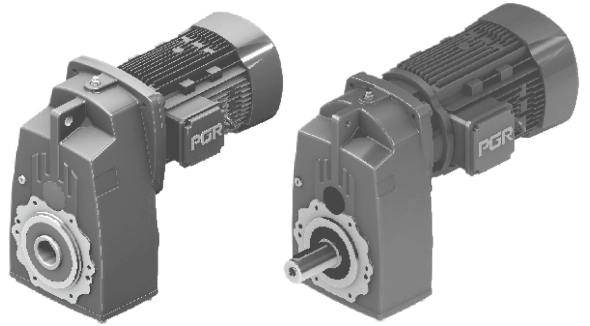

PD/PM 62 ... 82
PD/PM 63 ... 83

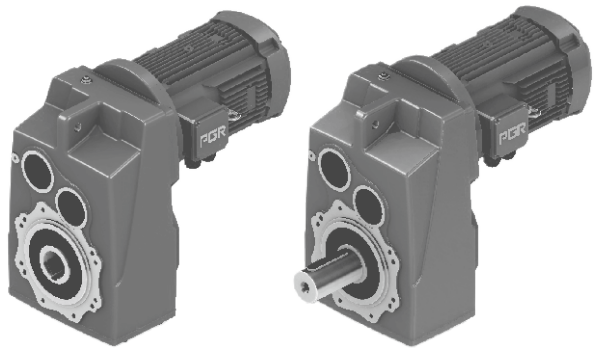

PD/PM 92 ... 112
PD/PM 93 ... 123

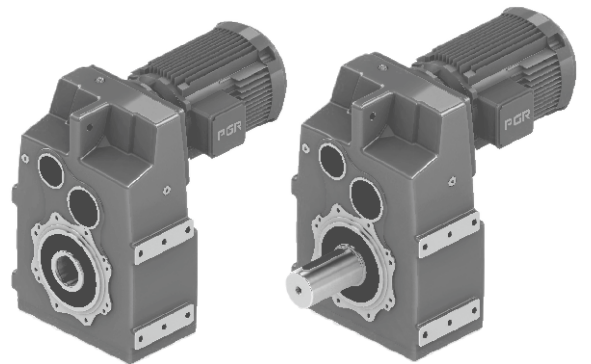

PD / PM

TR

TEKNİK TANIMLAR

Motorlu redüktör performans tablolarının yapısı.
Notify about performance tables for Geared motor.

0.37 kW

Redüktör motor gücü
Gear unit motor power

Motor gücü
Motor power

Çıkış devri
Output speed

Çıkış momenti
Output torque

Servis faktörü
Service factor

Tahvil oranı
Reduction ratio

Redüktör tipi
Gear unit motor type

Ağırlık
Weight

Ölçü sayfaları
Drawing page

P ₁ [kW]	n ₂ [Min ⁻¹]	M ₂ [Nm]	f _B	i _{ges}	F _R [kN]	F _A [kN]	F _{R GR} [kN]	F _{A GR} [kN]	Tip / Type	Kg	Sayfa Page mm
0.37	2.6	1375	1.5	532.76	20.0	22.0	29.0	30.0	PD 43 - 71M/4B PM 43 - 71M/4B	73	131
	3.1	1149	1.5	445.16	21.0	22.0	30.0	30.0			
	3.5	1009	2.0	391.14	21.0	22.0	30.0	30.0			

Müsaade edilebilir radyal yükler
Normal rulmanlarda
F_R için listelenmiş değerlerde
F_A = 0 (N) olarak hesaplanmıştır

Permissible radial force or load on output shaft while normal bearings are used. For this load F_A is assumed equal zero. F_A = 0 (N)

Müsaade edilebilir aksel yükler
Normal rulmanlarda
F_A için listelenmiş değerlerde
F_R = 0 (N) olarak hesaplanmıştır

Permissible axial force or load on output shaft while normal bearings are used. For this load F_R is assumed equal zero. F_R = 0 (N)

Müsaade edilebilir aksel yükler
Güçlendirilmiş rulmanlarda
F_A için listelenmiş değerlerde
F_R = 0 (N) olarak hesaplanmıştır

Permissible axial force on output shaft while reinforced bearings are used. For this load F_R is assumed equal to zero. F_R = 0 (N)

Müsaade edilebilir radyal yükler
Güçlendirilmiş rulmanlarda
F_A için listelenmiş değerlerde
F_R = 0 (N) olarak hesaplanmıştır.

Permissible radial force or load on output shaft while reinforced bearings are used. For this load F_A is assumed equal to zero. F_A = 0 (N)

P ₁ [kW]	n ₂ [Min ⁻¹]	M ₂ [Nm]	f _B	i _{ges}	F _R [kN]	F _A [kN]	F _{R GR} [kN]	F _{A GR} [kN]	Tip / Type	Kg	Sayfa Page mm
0.12	1.0	779	2.3	1343.79	21.0	22.0	30.0	30.0	PD 42/12 - 63M/4A PM 42/12 - 63M/4A	71	164
	1.2	644	2.8	1111.10	22.0	22.0	30.0	30.0			
	1.5	507	3.5	874.48	22.0	22.0	31.0	30.0			
	1.9	406	4.4	699.58	22.0	22.0	31.0	30.0			
	1.0	*1081	0.8	918.90	14.0	15.0	21.0	20.0	PD 33 - 63M/6 PM 33 - 63M/6	54	127
	1.1	1061	1.0	808.52	14.0	15.0	21.0	20.0			
	1.3	890	0.9	1022.54	15.0	15.0	22.0	20.0	PD 33 - 63M/4A PM 33 - 63M/4A	54	127
	1.4	799	1.0	918.90	15.0	15.0	22.0	20.0			
	1.6	703	1.5	808.52	15.0	15.0	22.0	20.0			
	1.8	632	1.5	726.57	15.0	15.0	22.0	20.0			
	2.3	508	2.0	584.11	16.0	15.0	22.0	20.0			
	2.7	420	2.1	482.75	16.0	15.0	23.0	20.0			
	3.2	355	2.2	408.42	16.0	15.0	23.0	20.0			
	0.9	*692	0.8	1423.90	7.0	12.0	12.0	15.0	PD/PM 22/02 - 63M/4A	39	164
	1.1	*567	0.8	762.96	8.0	12.0	13.0	15.0	PD 23 - 63M/6 PM 23 - 63M/6	38	123
	1.4	*650	0.8	622.96	7.0	12.0	12.0	15.0			
	1.7	*540	0.8	762.96	8.0	12.0	13.0	15.0	PD 23 - 63M/4A PM 23 - 63M/4A	38	123
	2.1	542	1.0	622.96	8.0	12.0	13.0	15.0			
	2.7	420	1.2	482.49	9.0	12.0	13.0	15.0			
	3.4	340	1.5	390.87	9.0	12.0	14.0	15.0			
	4.0	287	2.0	330.43	10.0	12.0	14.0	15.0			
	4.8	240	2.3	276.32	10.0	12.0	14.0	15.0			
	5.6	205	2.3	235.73	10.0	12.0	14.0	15.0			
	1.0	*376	0.8	1363.09	5.0	7.0	8.0	7.0	PD 12/02 - 63M/4A PM 12/02 - 63M/4A	28	164
	1.2	*352	0.8	1064.65	5.0	7.0	8.0	7.0			
	1.6	*364	0.8	824.73	5.0	7.0	8.0	7.0			
	2.0	*347	0.8	662.28	5.0	7.0	8.0	7.0			
	2.4	317	0.9	546.25	6.0	7.0	9.0	7.0			
	3.2	235	1.2	405.92	6.0	7.0	9.0	7.0			
	3.5	331	1.1	380.81	6.0	7.0	8.0	11.0	PD C13 - 63M/4A PM C13 - 63M/4A	26	116
	4.4	262	1.4	301.44	6.0	7.0	8.0	11.0			
	5.1	224	1.7	257.36	7.0	7.0	8.0	11.0			
	6.5	177	2.1	203.72	7.0	7.0	8.0	11.0			
	8.3	138	2.7	158.21	7.0	7.0	8.0	11.0			
	1.4	*283	0.8	633.80	6.0	7.0	-	-	PD 13 - 63M/6 PM 13 - 63M/6	24	119
	1.6	*287	0.8	556.59	6.0	7.0	-	-			
	1.8	*289	0.8	472.42	6.0	7.0	-	-			
	2.1	*281	0.8	633.80	6.0	7.0	-	-	PD 13 - 63M/4A PM 13 - 63M/4A	24	119
	2.4	*285	0.8	556.59	6.0	7.0	-	-			
	2.8	*282	0.8	472.42	6.0	7.0	-	-			
	3.2	*283	0.8	414.87	6.0	7.0	-	-			
	3.6	*283	0.8	368.83	6.0	7.0	-	-			
	4.4	262	1.0	301.08	6.0	7.0	-	-			
	5.2	219	1.3	251.58	6.0	7.0	-	-			
	6.3	182	1.3	209.76	7.0	7.0	-	-			
	8.0	144	1.5	109.45	7.0	7.0	10.0	7.0	PD 12 - 63M/6 PM 12 - 63M/6	20	118
	9.5	121	1.9	92.43	7.0	7.0	10.0	7.0			
	10.8	106	2.8	81.17	7.0	7.0	10.0	7.0			
	12.0	95	2.2	109.45	7.0	7.0	10.0	7.0	PD 12 - 63M/4A PM 12 - 63M/4A	20	118
	14.3	80	2.9	92.43	7.0	7.0	10.0	7.0			
	16.2	71	4.2	81.17	7.0	7.0	10.0	7.0			
	9.5	121	0.9	139.15	5.0	5.0	7.0	5.0	PD B02 - 63M/4A PM B02 - 63M/4A	14	114
	12.8	90	1.4	103.09	5.0	5.0	7.0	5.0			
	15.4	75	1.9	85.67	5.0	5.0	7.0	5.0			
	16.6	69	1.9	79.42	5.0	5.0	7.0	5.0			
	20.0	57	2.4	66.00	5.0	5.0	7.0	5.0			

* max. çıkış momenti $f_B = 0.8$
* max. output torque with $f_B = 0.8$

0.12 kW
0.18 kW

P ₁ [kW]	n ₂ [Min ⁻¹]	M ₂ [Nm]	f _B	i _{ges}	F _R [kN]	F _A [kN]	F _{R GR} [kN]	F _{A GR} [kN]	Tip / Type	Kg	Sayfa Page mm
0.12	16.1	71	0.9	81.73	5.0	5.0	5.0	8.0	PD A02 - 63M/4A PM A02 - 63M/4A	10	112
	22.2	52	2.1	59.32	5.0	5.0	5.0	8.0			
	26.5	43	2.3	49.62	5.0	5.0	5.0	8.0			
	31.5	36	2.3	41.88	5.0	5.0	5.0	8.0			
	34.9	33	3.0	37.71	5.0	5.0	5.0	8.0			
	37.9	30	3.4	34.80	5.0	5.0	5.0	8.0			
	41.4	28	3.4	31.83	5.0	5.0	5.0	8.0			
	45.3	25	4.3	29.11	5.0	5.0	5.0	8.0			
	53.6	21	5.4	24.57	4.0	5.0	5.0	8.0			
	59.0	19	5.6	22.34	4.0	5.0	5.0	8.0			
	70.2	16	5.8	18.77	4.0	5.0	5.0	8.0			
	79.7	14	6.9	16.54	4.0	5.0	5.0	8.0			
	88.3	13	5.8	14.91	4.0	5.0	5.0	8.0			
	95.2	12	9.1	13.83	4.0	5.0	5.0	8.0			
	112.8	10	10.8	11.67	4.0	5.0	5.0	8.0			
	138.8	8	13.1	9.49	3.0	5.0	5.0	8.0			
	152.6	8	13.1	8.63	3.0	5.0	5.0	8.0			
181.6	6	13.1	7.25	3.0	5.0	5.0	8.0				
207.6	6	14.6	6.35	3.0	5.0	5.0	8.0				
247.0	5	14.6	5.33	3.0	5.0	5.0	8.0				
311.0	4	14.6	4.24	3.0	4.0	5.0	8.0				
0.18	1.2	1088	2.8	1094.40	31.0	32.0	44.0	40.0	PD\PM 52/12 - 63M/4B	107	164
	1.0	1336	1.3	1343.79	20.0	22.0	29.0	30.0	PD 42/12 - 63M/4B PM 42/12 - 63M/4B	71	164
	1.2	1104	1.6	1111.10	21.0	22.0	30.0	30.0			
	1.5	869	2.1	874.48	21.0	22.0	30.0	30.0			
	1.9	695	2.6	699.58	22.0	22.0	30.0	30.0			
	2.4	555	3.2	557.93	22.0	22.0	31.0	30.0			
	3.3	407	4.4	409.62	22.0	22.0	31.0	30.0			
	3.9	339	5.3	341.25	22.0	22.0	31.0	30.0			
	4.5	300	6.0	302.14	22.0	22.0	31.0	30.0			
	1.2	1465	1.0	782.28	20.0	22.0	29.0	30.0	PD 43 - 71M/6A PM 43 - 71M/6A	81	131
	1.4	1224	1.0	653.66	20.0	22.0	30.0	30.0			
	1.7	998	2.0	532.76	21.0	22.0	30.0	30.0			
	2.1	834	2.0	445.16	21.0	22.0	30.0	30.0			
	1.3	1062	0.8	1068.11	13.0	15.0	21.0	20.0	PD\PM 32/12 - 63M/4B	56	164
	1.7	1033	1.0	808.52	13.0	15.0	21.0	20.0	PD 33 - 63M/4B PM 33 - 63M/4B	54	127
	1.9	928	1.0	726.57	14.0	15.0	21.0	20.0			
	2.3	746	1.3	584.11	15.0	15.0	22.0	20.0			
	2.8	617	1.4	482.75	15.0	15.0	22.0	20.0			
	3.3	522	1.5	408.42	16.0	15.0	22.0	20.0			
	4.7	367	2.6	287.08	16.0	15.0	23.0	20.0			
	5.8	295	3.4	230.79	16.0	15.0	23.0	20.0			
	7.1	244	3.6	190.74	16.0	15.0	23.0	20.0			
	2.0	659	0.8	662.62	7.0	12.0	12.0	15.0	PD 22/02 - 63M/4B PM 22/02 - 63M/4B	39	164
	2.6	511	1.0	514.10	8.0	12.0	13.0	15.0			
	2.8	616	0.8	482.49	7.0	12.0	12.0	15.0	PD 23 - 63M/4B PM 23 - 63M/4B	38	123
	3.4	499	1.0	390.87	8.0	12.0	13.0	15.0			
	4.1	422	1.3	330.43	9.0	12.0	13.0	15.0			
4.9	353	1.6	276.32	9.0	12.0	14.0	15.0				
5.7	301	1.6	235.73	10.0	12.0	14.0	15.0				
7.3	237	2.2	185.19	10.0	12.0	14.0	15.0				
7.2	239	1.6	127.46	10.0	12.0	14.0	15.0	PD 22 - 71M/6A PM 22 - 71M/6A	36	122	
8.8	195	2.0	104.07	10.0	12.0	14.0	15.0				
9.1	189	2.3	100.98	10.0	12.0	14.0	15.0				
4.1	326	0.9	328.02	6.0	7.0	9.0	7.0	PD 12/02 - 63M/4B PM 12/02 - 63M/4B	28	164	
4.7	282	1.0	284.03	6.0	7.0	9.0	7.0				
5.9	228	1.3	229.52	6.0	7.0	9.0	7.0				
3.5	487	0.8	380.81	4.0	7.0	8.0	11.0	PD C13 - 63M/4B PM C13 - 63M/4B	26	116	
4.5	385	1.0	301.44	5.0	7.0	8.0	11.0				
5.2	329	1.1	257.36	6.0	7.0	8.0	11.0				
6.6	260	1.4	203.72	6.0	7.0	8.0	11.0				
8.5	202	1.8	158.21	7.0	7.0	8.0	11.0				
9.9	174	2.1	136.54	7.0	7.0	8.0	11.0				
11.4	151	2.5	118.07	7.0	7.0	8.0	11.0				
12.7	135	2.7	106.03	7.0	7.0	8.0	11.0				
13.3	129	2.9	101.01	7.0	7.0	8.0	11.0				

P ₁ [kW]	n ₂ [Min ⁻¹]	M ₂ [Nm]	f _B	i _{ges}	F _R [kN]	F _A [kN]	F _{R GR} [kN]	F _{A GR} [kN]	Tip / Type	Kg	Sayfa Page mm	
0.18	5.3 6.4	321 268	0.9 0.9	251.58 209.76	6.0 6.0	7.0 7.0	- -	- -	PD 13 - 63M/4B PM 13 - 63M/4B	24	119	
	8.4 9.9 11.3	205 173 152	1.0 1.3 1.9	109.45 92.43 81.17	7.0 7.0 7.0	7.0 7.0 7.0	9.0 9.0 10.0	7.0 7.0 7.0	PD 12 - 71M/6A PM 12 - 71M/6A	23	118	
	12.3 14.6 16.6 20.3	140 118 104 85	1.5 2.0 2.9 3.2	109.45 92.43 81.17 66.26	7.0 7.0 7.0 6.0	7.0 7.0 7.0 7.0	10.0 10.0 10.0 10.0	7.0 7.0 7.0 7.0	PD 12 - 63M/4B PM 12 - 63M/4B	20	118	
	13.1 15.7 16.9 20.4 23.8 26.1 30.4 33.3	132 109 101 84 72 66 57 52	1.0 1.3 1.3 1.7 2.2 2.2 2.9 3.2	103.09 85.67 79.42 66.00 56.55 51.60 44.23 40.35	5.0 5.0 5.0 5.0 5.0 5.0 5.0 5.0	5.0 5.0 5.0 5.0 5.0 5.0 5.0 5.0	7.0 7.0 7.0 7.0 7.0 7.0 7.0 7.0	5.0 5.0 5.0 5.0 5.0 5.0 5.0 5.0	PD B02 - 63M/4B PM B02 - 63M/4B	14	114	
	22.7 27.1 32.1 35.7 38.7 42.3 46.2 54.8 60.2 71.7 81.4 90.2 97.3 115.3 141.8 155.9 185.5 212.0 252.3 317.6	76 63 53 48 44 41 37 31 29 24 21 19 18 15 12 11 9 8 7 5	1.5 1.6 1.6 2.1 2.3 2.3 3.0 3.7 3.8 4.0 4.7 3.9 6.2 7.4 8.9 8.9 8.9 9.9 10.0 9.9	59.32 49.62 41.88 37.71 34.80 31.83 29.11 24.57 22.34 18.77 16.54 14.91 13.83 11.67 9.49 8.63 7.25 6.35 5.33 4.24	5.0 5.0 5.0 5.0 5.0 5.0 5.0 4.0 4.0 4.0 4.0 4.0 4.0 3.0 3.0 3.0 3.0 3.0 3.0 3.0	5.0 5.0	5.0 5.0	8.0 8.0	PD A02 - 63M/4B PM A02 - 63M/4B	10	112	
	0.25	1.3 1.6 2.0	1579 1243 994	1.9 2.4 3.0	1094.40 861.34 689.07	31.0 31.0 31.0	32.0 32.0 32.0	44.0 44.0 44.0	40.0 40.0 40.0	PD 52/12 - 71M/4A PM 52/12 - 71M/4A	110	164
		1.0 1.3 1.6 2.0 2.5	1939 1603 1262 1009 805	0.9 1.1 1.4 1.8 2.2	1343.79 1111.10 874.48 699.58 557.93	17.0 19.0 20.0 21.0 21.0	22.0 22.0 22.0 22.0 22.0	27.0 28.0 30.0 30.0 30.0	30.0 30.0 30.0 30.0 30.0	PD 42/12 - 71M/4A PM 42/12 - 71M/4A	74	164
		1.2 1.8 2.1 2.6 3.1 3.6 4.3 5.1	1940 1344 1123 915 765 672 561 468	0.8 1.1 1.1 2.2 2.2 3.0 3.4 3.4	1129.42 782.28 653.66 532.76 445.16 391.14 326.83 272.49	17.0 20.0 21.0 21.0 22.0 22.0 22.0 22.0	22.0 22.0 22.0 22.0 22.0 22.0 22.0 22.0	27.0 29.0 30.0 30.0 30.0 30.0 31.0 31.0	30.0 30.0 30.0 30.0 30.0 30.0 30.0 30.0	PD 43 - 71M/4A PM 43 - 71M/4A	81	131
		1.9 2.4 2.9 3.4 4.8 6.0 7.3	1248 1003 829 702 493 396 328	0.8 1.0 1.0 1.1 1.9 2.5 2.6	726.57 584.11 482.75 408.42 287.08 230.79 190.74	12.0 14.0 15.0 15.0 16.0 16.0 16.0	15.0 15.0 15.0 15.0 15.0 15.0 15.0	20.0 21.0 22.0 22.0 23.0 23.0 23.0	20.0 20.0 20.0 20.0 20.0 20.0 20.0	PD 33 - 71M/4A PM 33 - 71M/4A	57	127
		8.2 9.1	292 262	2.6 3.1	112.23 100.85	16.0 16.0	15.0 15.0	23.0 23.0	20.0 20.0	PD 32 - 71M/6B PM 32 - 71M/6B	53	126
		12.4	193	4.0	112.23	16.0	15.0	23.0	20.0	PD/PM 32 - 71M/4A	51	126
		3.3	612	0.8	424.03	7.0	12.0	12.0	15.0	PD/PM 22/02 - 71M/4A	42	164

P ₁ [kW]	n ₂ [Min ⁻¹]	M ₂ [Nm]	f _B	i _{ges}	F _R [kN]	F _A [kN]	F _{R GR} [kN]	F _{A GR} [kN]	Tip / Type	Kg	Sayfa Page mm
0.25	3.6	671	0.8	390.87	7.0	12.0	12.0	15.0	PD 23 - 71M/4A PM 23 - 71M/4A	41	123
	4.2	568	1.0	330.43	8.0	12.0	13.0	15.0			
	5.0	475	1.2	276.32	9.0	12.0	13.0	15.0			
	5.9	405	1.2	235.73	9.0	12.0	13.0	15.0			
	7.2	331	1.1	127.46	9.0	12.0	14.0	15.0	PD 22 - 71M/6B PM 22 - 71M/6B	38	122
	8.8	270	1.5	104.07	10.0	12.0	14.0	15.0			
	9.1	262	1.7	100.98	10.0	12.0	14.0	15.0			
	10.9	219	1.7	127.46	10.0	12.0	14.0	15.0	PD/PM 22 - 71M/4A	36	122
	5.4	442	0.8	257.36	5.0	7.0	8.0	11.0	PD C13 - 71M/4A PM C13 - 71M/4A	29	116
	6.8	350	1.1	203.72	6.0	7.0	8.0	11.0			
	8.8	272	1.4	158.21	6.0	7.0	8.0	11.0			
	10.2	235	1.6	136.54	7.0	7.0	8.0	11.0			
	11.8	203	1.8	118.07	7.0	7.0	8.0	11.0			
	13.1	182	2.0	106.03	7.0	7.0	8.0	11.0			
	13.8	174	2.1	101.01	7.0	7.0	8.0	11.0			
	15.6	153	2.4	88.92	7.0	7.0	8.0	11.0			
	8.5	282	0.8	163.92	6.0	7.0	-	-	PD/PM 13 - 71M/4A	27	119
	9.9	240	1.0	92.43	6.0	7.0	9.0	7.0	PD 12 - 71M/6B PM 12 - 71M/6B	25	118
	11.3	211	1.4	81.17	6.0	7.0	9.0	7.0			
	12.7	188	1.1	109.45	7.0	7.0	9.0	7.0	PD 12 - 71M/4A PM 12 - 71M/4A	23	118
	15.0	159	1.5	92.43	7.0	7.0	9.0	7.0			
	17.1	139	2.1	81.17	6.0	7.0	10.0	7.0			
	21.0	114	2.4	66.26	6.0	7.0	10.0	7.0			
	25.1	95	2.5	55.37	6.0	7.0	10.0	7.0			
	30.1	79	2.5	46.16	6.0	7.0	10.0	7.0			
	16.2	147	1.0	85.67	5.0	5.0	7.0	5.0	PD B02 - 71M/4A PM B02 - 71M/4A	17	114
	17.5	136	0.9	79.42	5.0	5.0	7.0	5.0			
	21.1	113	1.2	66.00	5.0	5.0	7.0	5.0			
	24.6	97	1.6	56.55	5.0	5.0	7.0	5.0			
	26.9	89	1.6	51.60	5.0	5.0	7.0	5.0			
	31.4	76	2.2	44.23	5.0	5.0	7.0	5.0			
	34.4	69	2.4	40.35	5.0	5.0	7.0	5.0			
	40.7	59	2.6	34.16	5.0	5.0	7.0	5.0			
	46.2	52	2.5	30.08	4.0	5.0	7.0	5.0			
		23.4	102	1.1	59.32	5.0	5.0	5.0			
28.0		85	1.2	49.62	5.0	5.0	5.0	8.0			
33.2		72	1.2	41.88	5.0	5.0	5.0	8.0			
36.9		65	1.5	37.71	5.0	5.0	5.0	8.0			
39.9		60	1.7	34.80	5.0	5.0	5.0	8.0			
43.7		55	1.7	31.83	4.0	5.0	5.0	8.0			
47.8		50	2.2	29.11	4.0	5.0	5.0	8.0			
56.6		42	2.7	24.57	4.0	5.0	5.0	8.0			
62.2		38	2.8	22.34	4.0	5.0	5.0	8.0			
74.0		32	2.9	18.77	4.0	5.0	5.0	8.0			
84.1		28	3.5	16.54	4.0	5.0	5.0	8.0			
93.2		26	2.9	14.91	4.0	5.0	5.0	8.0			
100.5		24	4.6	13.83	4.0	5.0	5.0	8.0			
119.1		20	5.5	11.67	3.0	5.0	5.0	8.0			
146.4		16	6.6	9.49	3.0	5.0	5.0	8.0			
161.1		15	6.6	8.63	3.0	5.0	5.0	8.0			
191.6		12	6.7	7.25	3.0	5.0	5.0	8.0			
219.0		11	7.4	6.35	3.0	5.0	5.0	8.0			
260.6		9	7.4	5.33	3.0	4.0	5.0	8.0			
328.1		7	7.4	4.24	2.0	4.0	5.0	8.0			

P ₁ [kW]	n ₂ [Min ⁻¹]	M ₂ [Nm]	f _B	i _{ges}	F _R [kN]	F _A [kN]	F _{R GR} [kN]	F _{A GR} [kN]	Tip / Type	Kg	Sayfa Page mm
0.37	1.0	3090	2.3	1342.44	57.0	58.0	81.0	80.0	PD/PM 73/22 - 71M/4B	277	166
	1.1	2902	1.9	1260.77	39.0	47.0	57.0	60.0	PD 63/22 - 71M/4B PM 63/22 - 71M/4B	204	166
	1.2	2543	2.1	1104.71	40.0	47.0	57.0	60.0			
	1.7	1890	2.9	821.10	41.0	47.0	58.0	60.0			
	2.1	1467	3.7	637.34	41.0	47.0	58.0	60.0			
	1.0	3070	1.0	1333.49	25.0	32.0	40.0	40.0	PD 52/12 - 71M/4B	112	164
	1.3	2519	1.2	1094.40	28.0	32.0	42.0	40.0	PM 52/12 - 71M/4B		
	1.3	2687	1.2	699.67	27.0	32.0	42.0	40.0	PD 53 - 80M/6A PM 53 - 80M/6A	123	135
	1.6	2192	1.3	570.63	29.0	32.0	43.0	40.0			
	1.8	2015	1.6	524.75	30.0	32.0	43.0	40.0			
	2.1	1644	1.9	427.97	30.0	32.0	44.0	40.0			
	2.5	1389	2.0	361.64	31.0	32.0	44.0	40.0			
	3.4	1039	2.6	270.40	31.0	32.0	44.0	40.0			
	1.6	2013	0.9	874.48	17.0	22.0	27.0	30.0	PD/PM 42/12 - 71M/4B	76	164
	1.7	2046	1.0	532.76	17.0	22.0	27.0	30.0	PD 43 - 80M/6A	83	131
	2.1	1710	1.0	445.16	19.0	22.0	28.0	30.0	PM 43 - 80M/6A		
	2.6	1375	1.5	532.76	20.0	22.0	29.0	30.0	PD 43 - 71M/4B PM 43 - 71M/4B	83	131
	3.1	1149	1.5	445.16	21.0	22.0	30.0	30.0			
	3.5	1009	2.0	391.14	21.0	22.0	30.0	30.0			
	4.2	843	2.2	326.83	21.0	22.0	30.0	30.0			
	5.0	703	2.2	272.49	22.0	22.0	30.0	30.0			
	7.1	494	4.0	191.52	22.0	22.0	31.0	30.0			
	8.6	413	4.0	160.03	22.0	22.0	31.0	30.0			
	3.0	1062	0.8	461.30	13.0	15.0	21.0	20.0			
	3.8	825	1.1	358.19	15.0	15.0	22.0	20.0	PM 32/12 - 71M/4B		
	4.8	741	1.3	287.08	15.0	15.0	22.0	20.0	PD 33 - 71M/4B	59	127
	5.9	596	1.7	230.79	16.0	15.0	22.0	20.0	PM 33 - 71M/4B		
	7.2	492	1.8	190.74	16.0	15.0	23.0	20.0			
	8.2	431	1.8	112.23	16.0	15.0	23.0	20.0	PD 32 - 80M/6A	53	126
	9.1	387	2.1	100.85	16.0	15.0	23.0	20.0	PM 32 - 80M/6A		
	10.4	341	2.8	88.74	16.0	15.0	23.0	20.0			
	12.2	290	2.7	112.23	15.0	15.0	23.0	20.0	PD 32 - 71M/4B	53	126
	13.6	260	3.1	100.85	15.0	15.0	23.0	20.0	PM 32 - 71M/4B		
	4.8	663	0.8	288.06	7.0	12.0	12.0	15.0	PD/PM 22/02 - 71M/4B	44	164
	5.0	713	0.8	276.32	6.0	12.0	11.0	15.0	PD 23 - 71M/4B	43	123
	5.8	608	0.8	235.73	7.0	12.0	12.0	15.0	PM 23 - 71M/4B		
	7.2	490	0.8	127.46	9.0	12.0	13.0	15.0	PD 22 - 80M/6A	38	122
	8.8	400	1.0	104.07	9.0	12.0	13.0	15.0	PM 22 - 80M/6A		
	9.1	388	1.1	100.98	9.0	12.0	13.0	15.0			
	10.7	329	1.2	127.46	9.0	12.0	14.0	15.0	PD 22 - 71M/4B	38	122
	13.6	261	1.7	100.98	10.0	12.0	14.0	15.0	PM 22 - 71M/4B		
	16.6	213	2.2	82.45	10.0	12.0	14.0	15.0			
8.7	408	0.9	158.21	5.0	7.0	8.0	11.0	PD C13 - 71M/4B PM C13 - 71M/4B	31	116	
10.0	352	1.1	136.54	6.0	7.0	8.0	11.0				
11.6	305	1.2	118.07	6.0	7.0	8.0	11.0				
13.6	261	1.4	101.01	6.0	7.0	8.0	11.0				
15.4	229	1.6	88.92	7.0	7.0	8.0	11.0				
17.4	203	1.8	78.83	7.0	7.0	8.0	11.0				
20.1	176	2.1	68.27	7.0	7.0	8.0	11.0				
22.8	155	2.4	60.09	7.0	7.0	8.0	11.0				
25.7	137	2.6	53.28	7.0	7.0	8.0	11.0				
13.0	272	1.0	105.32	6.0	7.0	-	-				PD/PM 13 - 71M/4B
14.8	239	1.0	92.43	6.0	7.0	9.0	7.0	PD 12 - 71M/4B PM 12 - 71M/4B	25	118	
16.9	209	1.4	81.17	6.0	7.0	9.0	7.0				
19.0	186	1.6	72.16	6.0	7.0	9.0	7.0				
20.7	171	1.6	66.26	6.0	7.0	9.0	7.0				
23.2	152	1.9	58.91	6.0	7.0	10.0	7.0				
24.7	143	1.6	55.37	6.0	7.0	10.0	7.0				
27.8	127	2.0	49.22	5.0	7.0	10.0	7.0				
29.7	119	1.6	46.16	5.0	7.0	10.0	7.0				
33.4	106	2.0	41.04	5.0	7.0	10.0	7.0				
42.7	83	2.8	32.07	5.0	7.0	10.0	7.0				
48.3	73	3.1	28.35	5.0	7.0	10.0	7.0				
54.2	65	3.5	25.24	5.0	7.0	10.0	7.0				

0.37 kW
0.55 kW

P ₁ [kW]	n ₂ [Min ⁻¹]	M ₂ [Nm]	f _B	i _{ges}	F _R [kN]	F _A [kN]	F _{R GR} [kN]	F _{A GR} [kN]	Tip / Type	Kg	Sayfa Page mm			
0.37	20.7	170	0.8	66.00	5.0	5.0	7.0	5.0	PD B02 - 71M/4B PM B02 - 71M/4B	19	114			
	24.2	146	1.1	56.55	5.0	5.0	7.0	5.0						
	26.5	133	1.1	51.60	5.0	5.0	7.0	5.0						
	31.0	114	1.4	44.23	5.0	5.0	7.0	5.0						
	33.9	104	1.6	40.35	4.0	5.0	7.0	5.0						
	40.1	88	1.7	34.16	4.0	5.0	7.0	5.0						
	45.5	78	1.7	30.08	4.0	5.0	7.0	5.0						
	52.7	67	1.9	25.96	4.0	5.0	7.0	5.0						
	60.4	59	2.2	22.68	4.0	5.0	7.0	5.0						
	63.5	56	2.5	21.58	4.0	5.0	7.0	5.0						
	68.7	51	2.5	19.94	4.0	5.0	7.0	5.0						
	77.7	45	2.8	17.62	4.0	5.0	7.0	5.0						
	27.6	128	0.8	49.62	5.0	5.0	5.0	8.0				PD A02 - 71M/4B PM A02 - 71M/4B	15	112
	32.7	108	0.8	41.88	4.0	5.0	5.0	8.0						
	36.3	97	1.0	37.71	4.0	5.0	5.0	8.0						
	39.3	90	1.1	34.80	4.0	5.0	5.0	8.0						
	43.0	82	1.2	31.83	4.0	5.0	5.0	8.0						
	47.0	75	1.5	29.11	4.0	5.0	5.0	8.0						
	55.7	63	1.8	24.57	4.0	5.0	5.0	8.0						
	61.3	58	1.9	22.34	4.0	5.0	5.0	8.0						
	72.9	48	2.0	18.77	4.0	5.0	5.0	8.0						
	82.8	43	2.3	16.54	4.0	5.0	5.0	8.0						
	91.8	38	1.9	14.91	3.0	5.0	5.0	8.0						
	99.0	36	3.1	13.83	3.0	5.0	5.0	8.0						
	117.3	30	3.7	11.67	3.0	5.0	5.0	8.0						
	144.2	24	4.4	9.49	3.0	5.0	5.0	8.0						
	158.6	22	4.4	8.63	3.0	5.0	5.0	8.0						
188.8	19	4.4	7.25	3.0	5.0	5.0	8.0							
215.7	16	4.9	6.35	3.0	5.0	5.0	8.0							
256.7	14	4.9	5.33	3.0	4.0	5.0	8.0							
323.2	11	4.9	4.24	2.0	4.0	5.0	8.0							
0.55	1.0	4742	2.6	1362.94	92.0	73.0	100.0	100.0	PD 83/32 - 80M/4A PM 83/32 - 80M/4A	413	166			
	1.3	3694	3.3	1061.83	93.0	73.0	100.0	100.0						
	1.0	4670	1.5	1342.44	55.0	58.0	80.0	80.0	PD 73/22 - 80M/4A PM 73/22 - 80M/4A	277	166			
	1.3	3625	2.0	1042.00	57.0	58.0	81.0	80.0						
	1.5	3243	2.2	932.25	57.0	58.0	81.0	80.0						
	2.0	2471	2.9	710.29	58.0	58.0	82.0	80.0						
	1.1	4386	1.2	1260.77	34.0	47.0	54.0	60.0	PD 63/22 - 80M/4A PM 63/22 - 80M/4A	204	166			
	1.3	3843	1.4	1104.71	36.0	47.0	54.0	60.0						
	1.7	2857	1.9	821.10	39.0	47.0	57.0	60.0						
	2.2	2217	2.4	637.34	40.0	47.0	58.0	60.0						
	2.5	1984	2.7	570.21	41.0	47.0	58.0	60.0						
	3.2	1511	3.6	434.44	41.0	47.0	58.0	60.0						
	1.3	3995	0.8	699.67	20.0	32.0	37.0	40.0	PD/PM 53 - 80M/6B	125	135			
	1.5	3514	0.8	936.55	24.0	32.0	39.0	40.0	PD 53 - 80M/4A PM 53 - 80M/4A	123	135			
	2.0	2625	1.2	699.67	28.0	32.0	42.0	40.0						
	2.5	2141	1.3	570.63	29.0	32.0	43.0	40.0						
	2.7	1969	1.6	524.75	29.0	32.0	43.0	40.0						
	3.3	1606	2.0	427.97	30.0	32.0	44.0	40.0						
	3.9	1357	2.1	361.64	31.0	32.0	44.0	40.0						
	4.2	1244	2.6	331.54	31.0	32.0	44.0	40.0						
	5.2	1014	2.7	270.40	31.0	32.0	44.0	40.0						
	2.5	1941	0.9	557.93	17.0	22.0	28.0	30.0	PD/PM 42/12 - 80M/4A	76	164			
	2.6	1999	1.0	532.76	17.0	22.0	27.0	30.0	PD 43 - 80M/4A PM 43 - 80M/4A	83	131			
	3.1	1670	1.0	445.16	19.0	22.0	28.0	30.0						
	3.4	1548	1.3	412.63	19.0	22.0	29.0	30.0						
	3.6	1467	1.4	391.14	19.0	22.0	29.0	30.0						
	4.1	1294	1.3	344.78	20.0	22.0	29.0	30.0						
4.3	1226	1.5	326.83	20.0	22.0	30.0	30.0							
4.6	1137	1.8	302.94	21.0	22.0	30.0	30.0							
5.1	1022	1.5	272.49	21.0	22.0	30.0	30.0							
5.5	950	2.1	253.13	21.0	22.0	30.0	30.0							
6.6	792	2.1	211.05	21.0	22.0	30.0	30.0							
7.3	719	2.8	191.52	22.0	22.0	30.0	30.0							
8.7	600	2.7	160.03	22.0	22.0	31.0	30.0							
10.0	528	3.3	140.61	22.0	22.0	31.0	30.0							
11.8	445	3.6	118.53	22.0	22.0	31.0	30.0							
13.5	390	5.1	103.86	21.0	22.0	31.0	30.0							

P ₁ [kW]	n ₂ [Min ⁻¹]	M ₂ [Nm]	f _B	i _{ges}	F _R [kN]	F _A [kN]	F _{R GR} [kN]	F _{A GR} [kN]	Tip / Type	Kg	Sayfa Page mm
0.55	4.9	1077	0.9	287.08	13.0	15.0	21.0	20.0	PD 33 - 80M/4A PM 33 - 80M/4A	59	127
	6.1	866	1.2	230.79	15.0	15.0	22.0	20.0			
	7.3	716	1.2	190.74	15.0	15.0	22.0	20.0			
	8.2	641	1.2	112.23	15.0	15.0	22.0	20.0	PD 32 - 80M/6B PM 32 - 80M/6B	55	126
	9.1	576	1.4	100.85	16.0	15.0	22.0	20.0			
	10.4	507	1.9	88.74	15.0	15.0	22.0	20.0			
	11.5	455	1.9	79.75	15.0	15.0	23.0	20.0			
	12.5	421	1.8	112.23	15.0	15.0	23.0	20.0	PD 32 - 80M/4A PM 32 - 80M/4A	53	126
	13.9	378	2.1	100.85	14.0	15.0	23.0	20.0			
	15.8	333	2.8	88.74	14.0	15.0	23.0	20.0			
	17.6	299	2.8	79.75	13.0	15.0	23.0	20.0			
	19.9	265	2.1	70.52	13.0	15.0	23.0	20.0			
	21.2	247	3.1	65.91	13.0	15.0	23.0	20.0			
	8.0	611	0.9	175.52	7.0	12.0	12.0	15.0	PD/PM 22/02 - 80M/4A	44	164
	9.1	577	0.8	100.98	8.0	12.0	12.0	15.0	PD/PM 22 - 80M/6B	40	122
	11.0	478	0.8	127.46	9.0	12.0	13.0	15.0	PD 22 - 80M/4A PM 22 - 80M/4A	38	122
	13.5	390	1.0	104.07	9.0	12.0	13.0	15.0			
	13.9	379	1.2	100.98	9.0	12.0	13.0	15.0			
	17.0	309	1.5	82.45	10.0	12.0	14.0	15.0			
	20.1	261	1.7	69.70	10.0	12.0	14.0	15.0			
	21.9	240	2.2	63.86	10.0	12.0	14.0	15.0			
	25.9	203	2.5	53.98	10.0	12.0	14.0	15.0			
	31.0	169	2.7	45.14	10.0	12.0	14.0	15.0			
	11.9	443	0.8	118.07	5.0	7.0	8.0	11.0	PD C13 - 80M/4A PM C13 - 80M/4A	31	116
	13.2	398	0.9	106.03	5.0	7.0	8.0	11.0			
	13.9	379	1.0	101.01	5.0	7.0	8.0	11.0			
	15.7	334	1.1	88.92	6.0	7.0	8.0	11.0			
	17.8	296	1.3	78.83	6.0	7.0	8.0	11.0			
20.5	256	1.4	68.27	6.0	7.0	8.0	11.0				
23.3	225	1.6	60.09	7.0	7.0	8.0	11.0				
26.3	200	1.8	53.28	6.0	7.0	8.0	11.0				
31.6	166	2.0	44.33	6.0	7.0	8.0	11.0				
36.1	146	2.2	38.83	6.0	7.0	8.0	11.0				
39.2	134	2.2	35.71	6.0	7.0	8.0	11.0				
47.1	111	2.5	29.71	6.0	7.0	8.0	11.0				
19.4	271	1.1	72.16	5.0	7.0	9.0	7.0	PD 12 - 80M/4A PM 12 - 80M/4A	25	118	
23.8	221	1.3	58.91	5.0	7.0	9.0	7.0				
28.4	185	1.4	49.22	5.0	7.0	9.0	7.0				
34.1	154	1.4	41.04	5.0	7.0	9.0	7.0				
43.7	120	1.9	32.07	5.0	7.0	10.0	7.0				
49.4	106	2.1	28.35	5.0	7.0	10.0	7.0				
55.5	95	2.4	25.24	4.0	7.0	10.0	7.0				
67.9	77	2.9	20.61	4.0	7.0	10.0	7.0				
81.3	65	3.5	17.22	4.0	7.0	10.0	7.0				
27.1	194	0.8	51.60	4.0	5.0	7.0	5.0	PD B02 - 80M/4A PM B02 - 80M/4A	19	114	
31.7	166	1.0	44.23	4.0	5.0	7.0	5.0				
34.7	151	1.1	40.35	4.0	5.0	7.0	5.0				
41.0	128	1.2	34.16	4.0	5.0	7.0	5.0				
46.5	113	1.1	30.08	4.0	5.0	7.0	5.0				
53.9	97	1.3	25.96	4.0	5.0	7.0	5.0				
61.7	85	1.5	22.68	4.0	5.0	7.0	5.0				
64.9	81	1.7	21.58	4.0	5.0	7.0	5.0				
70.2	75	1.7	19.94	4.0	5.0	7.0	5.0				
79.4	66	2.0	17.62	4.0	5.0	7.0	5.0				
84.5	62	2.3	16.57	3.0	5.0	7.0	5.0				
98.6	53	3.1	14.20	3.0	5.0	7.0	5.0				

0.55 kW
0.75 kW

P ₁ [kW]	n ₂ [Min ⁻¹]	M ₂ [Nm]	f _B	i _{ges}	F _R [kN]	F _A [kN]	F _{R GR} [kN]	F _{A GR} [kN]	Tip / Type	Kg	Sayfa Page mm				
0.55	40.2	131	0.8	34.80	4.0	5.0	5.0	8.0	PD A02 - 80M/4A PM A02 - 80M/4A	15	112				
	44.0	119	0.8	31.83	4.0	5.0	5.0	8.0							
	48.1	109	1.0	29.11	4.0	5.0	5.0	8.0							
	57.0	92	1.3	24.57	4.0	5.0	5.0	8.0							
	62.7	84	1.3	22.34	4.0	5.0	5.0	8.0							
	74.6	70	1.3	18.77	3.0	5.0	5.0	8.0							
	84.7	62	1.6	16.54	3.0	5.0	5.0	8.0							
	93.9	56	1.3	14.91	3.0	5.0	5.0	8.0							
	101.2	52	2.1	13.83	3.0	5.0	5.0	8.0							
	119.9	44	2.5	11.67	3.0	5.0	5.0	8.0							
	147.5	36	3.1	9.49	3.0	5.0	5.0	8.0							
	162.2	32	3.1	8.63	3.0	5.0	5.0	8.0							
	193.0	27	3.1	7.25	3.0	5.0	5.0	8.0							
	220.6	24	3.4	6.35	3.0	4.0	5.0	8.0							
	262.5	20	3.4	5.33	3.0	4.0	5.0	8.0							
330.5	16	3.4	4.24	2.0	4.0	5.0	8.0								
0.75	1.0	6601	1.8	1362.94	90.0	73.0	100.0	100.0	PD 83/32 - 80M/4B PM 83/32 - 80M/4B	415	166				
	1.3	5143	2.4	1061.83	92.0	73.0	100.0	100.0							
	1.6	4306	2.8	889.06	92.0	73.0	100.0	100.0							
		1.0	6502	1.1	1342.44	50.0	58.0	77.0	80.0	PD 73/22 - 80M/4B PM 73/22 - 80M/4B	279	166			
		1.3	5047	1.4	1042.00	54.0	58.0	79.0	80.0						
		1.5	4515	1.6	932.25	55.0	58.0	80.0	80.0						
		2.0	3440	2.1	710.29	57.0	58.0	81.0	80.0						
		2.5	2764	2.6	570.70	58.0	58.0	82.0	80.0						
		1.1	6106	0.9	1260.77	25.0	47.0	48.0	60.0	PD 63/22 - 80M/4B PM 63/22 - 80M/4B	206	166			
		1.3	5350	1.0	1104.71	28.0	47.0	50.0	60.0						
		1.7	4171	1.2	552.15	35.0	47.0	54.0	60.0	PD 63 - 90S/6A PM 63 - 90S/6A	191	139			
		2.1	3368	1.2	445.80	38.0	47.0	56.0	60.0						
		2.4	2972	2.0	393.43	39.0	47.0	57.0	60.0						
		3.0	2400	2.4	317.64	40.0	47.0	57.0	60.0						
		3.8	1901	2.4	251.63	41.0	47.0	58.0	60.0						
		4.2	1706	2.4	225.83	41.0	47.0	58.0	60.0						
		1.8	3964	0.8	524.75	21.0	32.0	38.0	40.0	PD/PM 53 - 90S/6A	127	135			
		2.0	3580	0.9	699.67	23.0	32.0	39.0	40.0						
		2.5	2919	1.0	570.63	26.0	32.0	41.0	40.0						
		2.7	2685	1.2	524.75	27.0	32.0	41.0	40.0						
		3.3	2190	1.5	427.97	29.0	32.0	43.0	40.0						
		3.9	1850	1.5	361.64	30.0	32.0	43.0	40.0						
		4.2	1696	1.9	331.54	30.0	32.0	43.0	40.0						
		5.2	1383	2.0	270.40	31.0	32.0	44.0	40.0						
		5.6	1272	2.5	248.66	31.0	32.0	44.0	40.0						
		7.1	1013	2.6	134.05	31.0	32.0	44.0	40.0						
		3.4	2111	0.9	412.63	16.0	22.0	27.0	30.0	PD 43 - 80M/4B PM 43 - 80M/4B	85	131			
		3.6	2001	1.0	391.14	17.0	22.0	27.0	30.0						
		4.1	1764	0.9	344.78	18.0	22.0	28.0	30.0						
		4.3	1672	1.1	326.83	19.0	22.0	28.0	30.0						
		4.6	1550	1.3	302.94	19.0	22.0	29.0	30.0						
		5.1	1394	1.1	272.49	20.0	22.0	29.0	30.0						
		5.5	1295	1.5	253.13	20.0	22.0	29.0	30.0						
		6.6	1080	1.5	211.05	21.0	22.0	30.0	30.0						
		7.3	980	2.0	191.52	21.0	22.0	30.0	30.0						
		8.7	819	2.0	160.03	21.0	22.0	30.0	30.0						
10.0		719	2.6	140.61	22.0	22.0	30.0	30.0							
11.8		606	2.9	118.53	21.0	22.0	31.0	30.0							
13.5		531	3.0	103.86	21.0	22.0	31.0	30.0							
		6.1	1174	1.1	155.40	21.0	22.0	30.0	30.0				PD 42 - 90S/6A PM 42 - 90S/6A	74	130
		8.6	836	1.9	110.73	21.0	22.0	30.0	30.0						
	10.5	684	2.3	90.52	22.0	22.0	30.0	30.0							
	6.1	1181	0.8	230.79	13.0	15.0	20.0	20.0	PD 33 - 80M/4B PM 33 - 80M/4B	61	127				
	7.3	976	0.9	190.74	14.0	15.0	21.0	20.0							
	8.4	848	0.9	112.23	15.0	15.0	22.0	20.0	PD 32 - 90S/6A PM 32 - 90S/6A	57	126				
	9.4	762	1.1	100.85	15.0	15.0	22.0	20.0							
	10.7	670	1.4	88.74	14.0	15.0	22.0	20.0							
	11.9	602	1.4	79.75	14.0	15.0	22.0	20.0							

P ₁ [kW]	n ₂ [Min ⁻¹]	M ₂ [Nm]	f _B	i _{ges}	F _R [kN]	F _A [kN]	F _{R GR} [kN]	F _{A GR} [kN]	Tip / Type	Kg	Sayfa Page mm
0.75	12.5	574	1.3	112.23	14.0	15.0	22.0	20.0	PD 32 - 80M/4B PM 32 - 80M/4B	55	126
	13.9	516	1.6	100.85	14.0	15.0	22.0	20.0			
	15.8	454	2.1	88.74	13.0	15.0	23.0	20.0			
	17.6	408	2.1	79.75	13.0	15.0	23.0	20.0			
	19.9	361	1.6	70.52	13.0	15.0	23.0	20.0			
	21.2	337	2.2	65.91	12.0	15.0	23.0	20.0			
	25.1	285	2.3	55.76	12.0	15.0	23.0	20.0			
	29.2	246	2.2	48.00	11.0	15.0	22.0	20.0			
	33.3	215	2.8	42.05	11.0	15.0	21.0	20.0			
	37.0	193	2.8	37.79	11.0	15.0	21.0	20.0			
	12.0	596	0.9	116.40	8.0	12.0	12.0	15.0	PD/PM 23 - 80M/4B	45	123
	13.6	527	0.8	69.70	8.0	12.0	13.0	15.0	PD/PM 22 - 90S/6A	42	122
	13.9	517	0.9	100.98	8.0	12.0	13.0	15.0	PD 22 - 80M/4B PM 22 - 80M/4B	40	122
	17.0	422	1.1	82.45	9.0	12.0	13.0	15.0			
	20.1	357	1.2	69.70	9.0	12.0	14.0	15.0			
	21.9	327	1.6	63.86	9.0	12.0	14.0	15.0			
	25.9	276	1.8	53.98	10.0	12.0	14.0	15.0			
	31.0	231	1.9	45.14	10.0	12.0	14.0	15.0			
	37.7	190	2.4	37.18	9.0	12.0	14.0	15.0			
	47.2	152	2.7	29.64	9.0	12.0	14.0	15.0			
	52.2	137	3.0	26.81	9.0	12.0	14.0	15.0			
	15.7	455	0.8	88.92	4.0	7.0	8.0	11.0	PD C13 - 80M/4B PM C13 - 80M/4B	33	119
	17.8	403	0.9	78.83	5.0	7.0	8.0	11.0			
	20.5	349	1.1	68.27	6.0	7.0	8.0	11.0			
	23.3	307	1.2	60.09	6.0	7.0	8.0	11.0			
	26.3	273	1.3	53.28	6.0	7.0	8.0	11.0			
	31.6	227	1.5	44.33	6.0	7.0	8.0	11.0			
	36.1	199	1.6	38.83	6.0	7.0	8.0	11.0			
	39.2	183	1.6	35.71	6.0	7.0	8.0	11.0			
	47.1	152	1.9	29.71	5.0	7.0	8.0	11.0			
	53.8	133	2.0	26.02	5.0	7.0	8.0	11.0			
	19.4	369	0.8	72.16	5.0	7.0	8.0	7.0	PD 12 - 80M/4B PM 12 - 80M/4B	27	118
	23.8	301	0.9	58.91	5.0	7.0	9.0	7.0			
	28.4	252	1.0	49.22	5.0	7.0	9.0	7.0			
	34.1	210	1.0	41.04	5.0	7.0	9.0	7.0			
	43.7	164	1.4	32.07	4.0	7.0	9.0	7.0			
	49.4	145	1.6	28.35	4.0	7.0	10.0	7.0			
	55.5	129	1.7	25.24	4.0	7.0	10.0	7.0			
	67.9	105	2.1	20.61	4.0	7.0	10.0	7.0			
	81.3	88	2.5	17.22	4.0	7.0	10.0	7.0			
	34.7	206	0.8	40.35	4.0	5.0	7.0	5.0	PD B02 - 80M/4B PM B02 - 80M/4B	21	114
	41.0	175	0.9	34.16	4.0	5.0	7.0	5.0			
46.5	154	0.8	30.08	4.0	5.0	7.0	5.0				
53.9	133	1.0	25.96	4.0	5.0	7.0	5.0				
61.7	116	1.1	22.68	4.0	5.0	7.0	5.0				
64.9	110	1.3	21.58	3.0	5.0	7.0	5.0				
70.2	102	1.3	19.94	3.0	5.0	7.0	5.0				
79.4	90	1.4	17.62	3.0	5.0	7.0	5.0				
84.5	85	1.7	16.57	3.0	5.0	7.0	5.0				
98.6	73	2.2	14.20	3.0	5.0	7.0	5.0				
108.1	66	2.4	12.96	3.0	5.0	7.0	5.0				
124.1	58	2.4	11.28	3.0	5.0	7.0	5.0				
127.7	56	2.5	10.97	3.0	5.0	7.0	5.0				
57.0	126	0.9	24.57	3.0	5.0	5.0	8.0	PD A02 - 80M/4B PM A02 - 80M/4B			
62.7	114	1.0	22.34	3.0	5.0	5.0	8.0				
74.6	96	1.0	18.77	3.0	5.0	5.0	8.0				
84.7	85	1.2	16.54	3.0	5.0	5.0	8.0				
93.9	76	1.0	14.91	3.0	5.0	5.0	8.0				
101.2	71	1.6	13.83	3.0	5.0	5.0	8.0				
119.9	60	1.8	11.67	3.0	5.0	5.0	8.0				
147.5	49	2.3	9.49	3.0	5.0	5.0	8.0				
162.2	44	2.2	8.63	3.0	5.0	5.0	8.0				
193.0	37	2.2	7.25	3.0	4.0	5.0	8.0				
220.6	32	2.4	6.35	3.0	4.0	5.0	8.0				
262.5	27	2.5	5.33	2.0	4.0	5.0	8.0				
330.5	22	2.4	4.24	2.0	4.0	5.0	8.0				

P ₁ [kW]	n ₂ [Min ⁻¹]	M ₂ [Nm]	f _B	i _{ges}	F _R [kN]	F _A [kN]	F _{R GR} [kN]	F _{A GR} [kN]	Tip / Type	Kg	Sayfa Page mm		
1.10	1.0	10562	2.3	1417.68	120.0	102.0	120.0	130.0	PD 93/42 - 90S/4A PM 93/42 - 90S/4A	736	168		
	1.2	8772	2.7	1177.36	120.0	102.0	120.0	130.0					
	1.6	6599	3.6	885.67	115.0	102.0	120.0	130.0					
	1.0	10154	1.2	1362.94	85.0	73.0	100.0	100.0	PD 83/32 - 90S/4A PM 83/32 - 90S/4A	417	166		
	1.3	7911	1.5	1061.83	89.0	73.0	100.0	100.0					
	1.6	6624	1.8	889.06	90.0	73.0	100.0	100.0					
	2.0	5339	2.3	716.55	91.0	73.0	100.0	100.0					
	2.3	4545	2.7	610.07	92.0	73.0	100.0	100.0					
	2.6	4100	3.0	550.29	92.0	73.0	100.0	100.0	PD 83/42 - 90S/4A PM 83/42 - 90S/4A	434	168		
	3.0	3493	3.5	468.82	87.0	73.0	100.0	100.0					
	1.4	7763	0.9	1042.00	46.0	58.0	74.0	80.0	PD 73/22 - 90S/4A PM 73/22 - 90S/4A	281	166		
	1.5	6946	1.0	932.25	50.0	58.0	76.0	80.0					
	2.0	5292	1.3	710.29	54.0	58.0	79.0	80.0					
	2.5	4252	1.7	570.70	56.0	58.0	80.0	80.0					
	3.2	3240	2.2	434.82	57.0	58.0	81.0	80.0					
	1.7	6023	0.9	552.15	25.0	47.0	48.0	60.0				PD 63 - 90L/6B PM 63 - 90L/6B	193
	2.2	4863	0.9	445.80	32.0	47.0	52.0	60.0					
	2.4	4292	1.4	393.43	35.0	47.0	54.0	60.0					
	2.6	4114	1.3	552.15	35.0	47.0	54.0	60.0	PD 63 - 90S/4A PM 63 - 90S/4A	191	139		
	3.2	3321	1.3	445.80	38.0	47.0	56.0	60.0					
	3.6	2931	2.0	393.43	39.0	47.0	57.0	60.0					
	4.4	2367	2.4	317.64	40.0	47.0	57.0	60.0					
	5.6	1875	2.4	251.63	41.0	47.0	58.0	60.0					
	6.2	1683	2.4	225.83	41.0	47.0	58.0	60.0					
	8.8	1193	3.5	160.11	42.0	47.0	59.0	60.0					
	2.7	3910	0.8	524.75	21.0	32.0	38.0	40.0				PD 53 - 90S/4A PM 53 - 90S/4A	127
	3.3	3189	1.0	427.97	25.0	32.0	40.0	40.0					
	3.9	2694	1.0	361.64	27.0	32.0	42.0	40.0					
	4.3	2470	1.3	331.54	28.0	32.0	42.0	40.0					
	5.2	2015	1.3	270.40	29.0	32.0	43.0	40.0					
	5.7	1853	1.7	248.66	30.0	32.0	43.0	40.0					
	7.2	1462	1.8	134.05	31.0	32.0	44.0	40.0	PD 52 - 90L/6B PM 52 - 90L/6B	112	134		
	9.6	1092	2.1	100.15	31.0	32.0	44.0	40.0					
	10.5	999	2.7	134.05	31.0	32.0	44.0	40.0	PD/PM 52 - 90S/4A	110	134		
	4.3	2435	0.8	326.83	14.0	22.0	25.0	30.0	PD 43 - 90S/4A PM 43 - 90S/4A	87	131		
	4.7	2257	0.9	302.94	15.0	22.0	26.0	30.0					
	5.2	2030	0.8	272.49	17.0	22.0	27.0	30.0					
	5.6	1886	1.1	253.13	18.0	22.0	28.0	30.0					
	6.2	1695	0.8	155.40	18.0	22.0	28.0	30.0	PD 42 - 90L/6B PM 42 - 90L/6B	76	130		
	8.7	1208	1.3	110.73	20.0	22.0	30.0	30.0					
	9.1	1158	1.1	155.40	21.0	22.0	30.0	30.0	PD 42 - 90S/4A PM 42 - 90S/4A	74	130		
	12.7	825	1.9	110.73	20.0	22.0	30.0	30.0					
	15.6	674	2.4	90.52	19.0	22.0	30.0	30.0					
	10.0	1054	0.9	141.42	13.0	15.0	21.0	20.0	PD/PM 32/12 - 90S/4A	65	164		
	10.9	968	1.0	88.74	13.0	15.0	21.0	20.0	PD 32 - 90L/6B PM 32 - 90L/6B	59	126		
	12.1	870	1.0	79.75	13.0	15.0	22.0	20.0					
12.6	836	0.9	112.23	13.0	15.0	22.0	20.0	PD 32 - 90S/4A PM 32 - 90S/4A	57	126			
14.0	751	1.1	100.85	13.0	15.0	22.0	20.0						
15.9	661	1.4	88.74	12.0	15.0	22.0	20.0						
17.7	594	1.4	79.75	12.0	15.0	22.0	20.0						
20.0	525	1.1	70.52	12.0	15.0	22.0	20.0						
21.4	491	1.5	65.91	12.0	15.0	23.0	20.0						
22.0	478	2.1	64.11	12.0	15.0	23.0	20.0						
25.3	415	1.5	55.76	11.0	15.0	22.0	20.0						
26.6	395	2.1	52.98	11.0	15.0	22.0	20.0						
29.4	358	1.5	48.00	11.0	15.0	21.0	20.0						
31.5	334	2.2	44.83	11.0	15.0	21.0	20.0						
33.5	313	3.0	42.05	11.0	15.0	21.0	20.0						
36.5	287	2.2	38.59	10.0	15.0	20.0	20.0						
37.3	282	3.0	37.79	10.0	15.0	20.0	20.0						
44.2	238	3.3	31.90	10.0	15.0	19.0	20.0						
14.3	733	0.8	98.40	5.0	12.0	11.0	15.0				PD/PM 23 - 90S/4A	47	123

P ₁ [kW]	n ₂ [Min ⁻¹]	M ₂ [Nm]	f _B	i _{ges}	F _R [kN]	F _A [kN]	F _{R GR} [kN]	F _{A GR} [kN]	Tip / Type	Kg	Sayfa Page mm
1.10	17.1	614	0.8	82.45	7.0	12.0	12.0	15.0	PD 22 - 90S/4A PM 22 - 90S/4A	42	122
	20.2	519	0.9	69.70	8.0	12.0	13.0	15.0			
	22.1	476	1.1	63.86	9.0	12.0	13.0	15.0			
	26.1	402	1.3	53.98	9.0	12.0	13.0	15.0			
	27.3	385	1.4	51.73	9.0	12.0	13.0	15.0			
	31.2	336	1.3	45.14	9.0	12.0	14.0	15.0			
	32.2	326	1.7	43.73	9.0	12.0	14.0	15.0			
	38.6	272	1.8	36.57	9.0	12.0	14.0	15.0			
	45.2	232	1.9	31.20	9.0	12.0	14.0	15.0			
	47.6	221	2.3	29.64	9.0	12.0	14.0	15.0			
	52.6	200	2.2	26.81	8.0	12.0	14.0	15.0			
	56.4	186	2.6	24.98	8.0	12.0	14.0	15.0			
	58.8	179	2.4	23.99	8.0	12.0	14.0	15.0			
	64.4	163	2.9	21.89	8.0	12.0	14.0	15.0			
	76.2	138	3.1	18.51	8.0	12.0	14.0	15.0			
	85.2	123	3.3	16.56	7.0	12.0	14.0	15.0			
	23.5	448	0.8	60.09	4.0	7.0	8.0	11.0	PD C13 - 90S/4A PM C13 - 90S/4A	35	116
	26.5	397	0.9	53.28	5.0	7.0	8.0	11.0			
	31.8	330	1.0	44.33	5.0	7.0	8.0	11.0			
	36.3	289	1.1	38.83	5.0	7.0	8.0	11.0			
	39.5	266	1.1	35.71	5.0	7.0	8.0	11.0			
	47.5	221	1.3	29.71	5.0	7.0	8.0	11.0			
	54.2	194	1.4	26.02	5.0	7.0	8.0	11.0			
	58.3	180	1.5	24.17	5.0	7.0	8.0	11.0			
	75.2	140	1.7	18.76	5.0	7.0	8.0	11.0			
	87.0	121	1.9	16.20	4.0	7.0	8.0	11.0			
	44.0	239	1.0	32.07	4.0	7.0	9.0	7.0	PD 12 - 90S/4A PM 12 - 90S/4A	29	118
	49.7	211	1.1	28.35	4.0	7.0	9.0	7.0			
	55.9	188	1.2	25.24	4.0	7.0	9.0	7.0			
	68.4	154	1.5	20.61	4.0	7.0	10.0	7.0			
	81.9	128	1.7	17.22	4.0	7.0	10.0	7.0			
	100.1	105	2.0	14.09	3.0	7.0	10.0	7.0			
	120.0	88	2.3	11.75	3.0	6.0	10.0	7.0			
	136.3	77	2.5	10.34	3.0	6.0	9.0	7.0			
	70.7	149	0.9	19.94	3.0	5.0	7.0	5.0	PD B02 - 90S/4A PM B02 - 90S/4A	23	114
	80.0	131	1.0	17.62	3.0	5.0	7.0	5.0			
	85.1	123	1.1	16.57	3.0	5.0	7.0	5.0			
	99.3	106	1.5	14.20	3.0	5.0	7.0	5.0			
	108.8	97	1.7	12.96	3.0	5.0	7.0	5.0			
	125.0	84	1.7	11.28	3.0	5.0	7.0	5.0			
	128.6	82	1.9	10.97	3.0	5.0	7.0	5.0			
	145.9	72	1.9	9.67	3.0	5.0	7.0	5.0			
	159.9	66	2.1	8.82	3.0	5.0	7.0	5.0			
	188.8	56	2.3	7.47	3.0	4.0	7.0	5.0			
	1.50	1.0	14302	1.7	1417.68	120.0	102.0	120.0			
1.2		11877	2.0	1177.36	119.0	102.0	120.0	130.0			
1.6		8935	2.7	885.67	110.0	102.0	120.0	130.0			
2.0		7217	3.3	715.36	105.0	102.0	120.0	130.0			
2.3		6243	3.1	618.83	101.0	102.0	120.0	130.0			
1.0		13749	0.9	1362.94	76.0	73.0	100.0	100.0	PD 83/32 - 90L/4A PM 83/32 - 90L/4A	419	166
1.3		10712	1.1	1061.83	84.0	73.0	100.0	100.0			
1.6		8969	1.3	889.06	87.0	73.0	100.0	100.0			
2.0		7229	1.7	716.55	89.0	73.0	100.0	100.0			
2.3		6154	2.0	610.07	90.0	73.0	100.0	100.0			
2.6		5551	2.2	550.29	88.0	73.0	100.0	100.0	PD 83/42 - 90L/4A PM 83/42 - 90L/4A	436	168
3.0		4730	2.6	468.82	84.0	73.0	100.0	100.0			
4.1		3499	3.2	346.82	78.0	73.0	100.0	100.0			
2.4		6009	2.1	386.39	89.0	73.0	100.0	105.0	PD 83 - 100L/6A PM 83 - 100L/6A	402	147
2.9		4947	2.6	318.11	85.0	73.0	100.0	105.0			
2.0		7165	1.0	710.29	49.0	58.0	76.0	80.0	PD 73/22 - 90L/4A PM 73/22 - 90L/4A	283	166
2.5		5757	1.2	570.70	52.0	58.0	78.0	80.0			
3.3		4386	1.6	434.82	55.0	58.0	80.0	80.0			
3.8		3795	1.9	376.24	56.0	58.0	81.0	80.0			
4.8		2977	2.4	295.06	57.0	58.0	81.0	80.0	PD 73/32 - 90L/4A PM 73/32 - 90L/4A	294	166
6.4		2250	3.0	223.01	57.0	58.0	82.0	80.0			

P ₁ [kW]	n ₂ [Min ⁻¹]	M ₂ [Nm]	f _B	i _{ges}	F _R [kN]	F _A [kN]	F _{R GR} [kN]	F _{A GR} [kN]	Tip / Type	Kg	Sayfa Page mm
1.50	2.7	5262	1.4	338.37	54.0	58.0	79.0	80.0	PD 73 - 100L/6A	277	143
	3.4	4250	1.8	273.32	56.0	58.0	80.0	PM 73 - 100L/6A			
	2.2	6429	0.8	637.34	22.0	47.0	47.0	60.0	PD/PM 63/22 - 90L/4A	210	166
	2.3	6118	1.0	393.43	26.0	47.0	49.0	60.0	PD/PM 63 - 100L/6A	201	139
	2.6	5570	0.9	552.15	28.0	47.0	50.0	60.0	PD 63 - 90L/4A PM 63 - 90L/4A	193	139
	3.2	4497	0.9	445.80	34.0	47.0	53.0	60.0			
	3.6	3969	1.5	393.43	36.0	47.0	54.0	60.0			
	4.5	3204	1.8	317.64	38.0	47.0	56.0	60.0			
	5.6	2538	1.8	251.63	40.0	47.0	57.0	60.0			
	6.3	2278	1.8	225.83	40.0	47.0	58.0	60.0			
	8.9	1615	2.7	160.11	41.0	47.0	58.0	60.0			
	3.9	3648	0.8	361.64	23.0	32.0	39.0	40.0	PD 53 - 90L/4A PM 53 - 90L/4A	129	135
	4.3	3345	1.0	331.54	24.0	32.0	40.0	40.0			
	5.3	2728	1.0	270.40	27.0	32.0	41.0	40.0			
	5.7	2508	1.3	248.66	28.0	32.0	42.0	40.0			
	7.0	2046	1.6	202.80	29.0	32.0	43.0	40.0			
	6.9	2085	1.3	134.05	29.0	32.0	43.0	40.0	PD 52 - 100L/6A PM 52 - 100L/6A	120	134
	9.2	1557	1.4	100.15	31.0	32.0	44.0	40.0			
	10.0	1428	1.9	91.82	30.0	32.0	44.0	40.0			
	10.6	1352	2.0	134.05	30.0	32.0	44.0	40.0	PD 52 - 90L/4A PM 52 - 90L/4A	112	134
	14.2	1010	2.2	100.15	28.0	32.0	44.0	40.0			
	17.4	824	2.2	81.68	26.0	32.0	44.0	40.0			
	25.6	560	3.4	55.55	24.0	32.0	45.0	40.0			
	5.6	2554	0.8	253.13	12.0	22.0	25.0	30.0	PD 43 - 90L/4A PM 43 - 90L/4A	89	131
	6.7	2129	0.8	211.05	16.0	22.0	27.0	30.0			
	7.4	1932	1.0	191.52	17.0	22.0	28.0	30.0			
	8.3	1722	0.9	110.73	19.0	22.0	28.0	30.0	PD/PM 42 - 100L/6A	84	130
	9.1	1568	0.8	155.40	19.0	22.0	29.0	30.0	PD 42 - 90L/4A PM 42 - 90L/4A	76	130
	12.8	1117	1.4	110.73	19.0	22.0	30.0	30.0			
	15.7	913	1.8	90.52	19.0	22.0	30.0	30.0			
	31.5	455	2.6	45.06	16.0	22.0	30.0	30.0			
	12.5	1150	0.8	114.01	11.0	15.0	20.0	20.0			
14.4	997	1.0	64.11	11.0	15.0	21.0	20.0	PD/PM 32 - 100L/6A	68	126	
16.0	895	1.1	88.74	11.0	15.0	22.0	20.0	PD 32 - 90L/4A PM 32 - 90L/4A	59	126	
17.8	804	1.1	79.75	11.0	15.0	22.0	20.0				
21.5	665	1.1	65.91	11.0	15.0	22.0	20.0				
22.1	647	1.6	64.11	11.0	15.0	22.0	20.0				
25.5	563	1.1	55.76	10.0	15.0	22.0	20.0				
26.8	535	1.6	52.98	10.0	15.0	22.0	20.0				
29.6	484	1.1	48.00	10.0	15.0	21.0	20.0				
31.7	452	1.6	44.83	10.0	15.0	21.0	20.0				
33.8	424	2.2	42.05	10.0	15.0	20.0	20.0				
36.8	389	1.6	38.59	10.0	15.0	20.0	20.0				
37.6	381	2.2	37.79	10.0	15.0	20.0	20.0				
44.5	322	2.4	31.90	9.0	15.0	19.0	20.0				
49.5	289	2.5	28.67	9.0	15.0	18.0	20.0				
54.9	261	2.5	25.86	9.0	15.0	18.0	20.0				
59.9	239	2.4	23.69	9.0	15.0	18.0	20.0				
63.3	226	2.8	22.42	9.0	15.0	17.0	20.0				
22.2	644	0.8	63.86	7.0	12.0	12.0	15.0				PD 22 - 90L/4A PM 22 - 90L/4A
26.3	545	0.9	53.98	8.0	12.0	13.0	15.0				
27.4	522	1.0	51.73	8.0	12.0	13.0	15.0				
31.5	455	1.0	45.14	9.0	12.0	13.0	15.0				
32.5	441	1.3	43.73	9.0	12.0	13.0	15.0				
38.8	369	1.4	36.57	8.0	12.0	13.0	15.0				
45.5	315	1.4	31.20	8.0	12.0	14.0	15.0				
47.9	299	1.7	29.64	8.0	12.0	14.0	15.0				
53.0	270	1.6	26.81	8.0	12.0	14.0	15.0				
56.8	252	1.9	24.98	8.0	12.0	14.0	15.0				
59.2	242	1.8	23.99	8.0	12.0	14.0	15.0				
64.9	221	2.2	21.89	8.0	12.0	14.0	15.0				
76.7	187	2.4	18.51	7.0	12.0	14.0	15.0				
85.8	167	2.4	16.56	7.0	12.0	14.0	15.0				
107.6	133	2.4	13.20	7.0	12.0	13.0	15.0				
120.2	119	2.4	11.81	6.0	12.0	13.0	15.0				
139.8	102	2.6	10.16	6.0	12.0	12.0	15.0				

P ₁ [kW]	n ₂ [Min ⁻¹]	M ₂ [Nm]	f _B	i _{ges}	F _R [kN]	F _A [kN]	F _{R GR} [kN]	F _{A GR} [kN]	Tip / Type	Kg	Sayfa Page mm
1.50	36.6	392	0.8	38.83	4.0	7.0	8.0	11.0	PD C13 - 90L/4A PM C13 - 90L/4A	37	116
	39.8	360	0.8	35.71	4.0	7.0	8.0	11.0			
	47.8	300	0.9	29.71	4.0	7.0	8.0	11.0			
	54.6	263	1.0	26.02	4.0	7.0	8.0	11.0			
	58.7	244	1.1	24.17	4.0	7.0	8.0	11.0			
	75.7	189	1.3	18.76	4.0	7.0	8.0	11.0			
	87.6	163	1.4	16.20	4.0	7.0	8.0	11.0			
	50.1	286	0.8	28.35	3.0	7.0	9.0	7.0			
	56.3	255	0.9	25.24	3.0	7.0	9.0	7.0			
	68.9	208	1.1	20.61	3.0	7.0	9.0	7.0			
	82.5	174	1.3	17.22	3.0	6.0	9.0	7.0			
	100.8	142	1.5	14.09	3.0	6.0	10.0	7.0			
	120.9	118	1.7	11.75	3.0	6.0	9.0	7.0			
	137.3	104	1.9	10.34	3.0	6.0	9.0	7.0			
	155.0	92	2.0	9.16	3.0	6.0	9.0	7.0			
	172.5	83	2.3	8.23	3.0	5.0	9.0	7.0			
	173.6	83	1.9	8.18	3.0	5.0	9.0	7.0			
	195.9	73	2.4	7.25	3.0	5.0	8.0	7.0			
	221.3	65	2.5	6.42	3.0	5.0	8.0	7.0			
	85.7	167	0.8	16.57	3.0	5.0	7.0	5.0	PD B02 - 90L/4A PM B02 - 90L/4A	25	114
	100.0	143	1.1	14.20	3.0	5.0	7.0	5.0			
	109.6	131	1.2	12.96	3.0	5.0	7.0	5.0			
	125.9	114	1.2	11.28	3.0	5.0	7.0	5.0			
	129.5	111	1.4	10.97	3.0	4.0	7.0	5.0			
	146.9	98	1.4	9.67	3.0	4.0	7.0	5.0			
	161.0	89	1.5	8.82	3.0	4.0	7.0	5.0			
	190.2	75	1.7	7.47	2.0	4.0	7.0	5.0			
	220.2	65	1.9	6.43	2.0	4.0	7.0	5.0			
236.7	61	2.0	6.00	2.0	4.0	7.0	5.0				
274.0	52	2.1	5.17	2.0	4.0	7.0	5.0				
304.3	47	2.0	4.67	2.0	4.0	7.0	5.0				
352.3	41	2.1	4.02	2.0	3.0	7.0	5.0				
2.20	1.0	20604	2.9	1382.74	-	-	142.0	170.0			
	1.0	21113	1.7	1416.90	-	-	127.0	150.0	PD 103/52 - 100L/4A PM 103/52 - 100L/4A	1339	168
	1.2	17368	2.0	1165.61	-	-	130.0	150.0			
	1.5	13647	2.6	915.84	-	-	134.0	150.0			
	1.0	21124	1.1	1417.68	111.0	102.0	120.0	130.0	PD 93/42 - 100L/4A PM 93/42 - 100L/4A	746	168
	1.2	17543	1.4	1177.36	109.0	102.0	120.0	130.0			
	1.6	13197	1.8	885.67	103.0	102.0	120.0	130.0			
	2.0	10659	2.3	715.36	99.0	102.0	120.0	130.0			
	2.3	9221	2.6	618.83	96.0	102.0	120.0	130.0			
	3.1	6718	3.5	450.86	89.0	102.0	120.0	130.0			
	3.4	6117	3.9	410.49	87.0	102.0	120.0	130.0	PD/PM 93/52 - 100L/4A	775	168
	1.6	13248	0.9	889.06	79.0	73.0	100.0	100.0	PD 83/32 - 100L/4A PM 83/32 - 100L/4A	428	166
	2.0	10677	1.1	716.55	84.0	73.0	100.0	100.0			
	2.3	9090	1.3	610.07	82.0	73.0	100.0	100.0			
	2.6	8200	1.4	550.29	81.0	73.0	100.0	100.0	PD 83/42 - 100L/4A PM 83/42 - 100L/4A	444	168
	3.0	6986	1.7	468.82	78.0	73.0	100.0	100.0			
	3.6	5757	2.2	386.39	76.0	73.0	100.0	105.0	PD 83 - 100L/4A PM 83 - 100L/4A	402	147
	4.4	4740	2.7	318.11	72.0	73.0	100.0	105.0			
	2.5	8504	0.8	570.70	45.0	58.0	73.0	80.0	PD 73/22 - 100L/4A PM 73/22 - 100L/4A	292	166
	3.2	6479	1.1	434.82	51.0	58.0	77.0	80.0			
3.7	5606	1.3	376.24	53.0	58.0	79.0	80.0				
4.2	5042	1.5	338.37	55.0	58.0	79.0	80.0	PD 73 - 100L/4A PM 73 - 100L/4A	277	143	
5.2	4073	1.9	273.32	56.0	58.0	81.0	80.0				
6.5	3225	2.6	216.45	53.0	58.0	81.0	80.0				
6.9	3050	2.5	204.72	53.0	58.0	81.0	80.0				
3.2	6474	0.8	434.44	23.0	47.0	47.0	60.0	PD/PM 63/22 - 100L/4A	219	166	

P ₁ [kW]	n ₂ [Min ⁻¹]	M ₂ [Nm]	f _B	i _{ges}	F _R [kN]	F _A [kN]	F _{R GR} [kN]	F _{A GR} [kN]	Tip / Type	Kg	Sayfa Page mm			
2.20	3.6	5862	1.0	393.43	28.0	47.0	50.0	60.0	PD 63 - 100L/4A PM 63 - 100L/4A	201	139			
	4.4	4733	1.2	317.64	33.0	47.0	53.0	60.0						
	5.3	3992	1.5	267.94	36.0	47.0	55.0	60.0						
	5.6	3750	1.2	251.63	37.0	47.0	55.0	60.0						
	6.2	3365	1.2	225.83	38.0	47.0	56.0	60.0						
	6.6	3163	1.5	212.26	39.0	47.0	56.0	60.0						
	8.2	2554	2.2	171.37	40.0	47.0	57.0	60.0						
	8.8	2386	2.4	160.11	40.0	47.0	58.0	60.0						
	11.1	1890	2.4	126.84	41.0	47.0	58.0	60.0						
	12.3	1710	2.9	114.79	41.0	47.0	58.0	60.0						
	15.2	1381	2.9	92.68	39.0	47.0	59.0	60.0						
	18.7	1122	3.2	75.30	37.0	47.0	59.0	60.0						
	19.2	1094	2.9	73.42	37.0	47.0	59.0	60.0						
	5.2	4065	0.7	272.80	21.0	32.0	38.0	40.0				PD/PM 52/12 - 100L/4A	127	164
	5.7	3705	0.9	248.66	23.0	32.0	39.0	40.0				PD 53 - 100L/4A PM 53 - 100L/4A	138	135
	7.0	3022	1.1	202.80	26.0	32.0	41.0	40.0						
	8.2	2553	1.1	171.36	28.0	32.0	42.0	40.0						
	9.2	2292	1.4	153.85	28.0	32.0	43.0	40.0						
	10.2	2068	1.5	138.78	28.0	32.0	43.0	40.0						
10.5	1998	1.3	134.05	28.0	32.0	43.0	40.0	PD 52 - 100L/4A PM 52 - 100L/4A	120	134				
14.1	1492	1.5	100.15	26.0	32.0	44.0	40.0							
15.4	1368	2.0	91.82	26.0	32.0	44.0	40.0							
17.3	1217	1.5	81.68	25.0	32.0	44.0	40.0							
20.6	1022	2.9	68.60	24.0	32.0	44.0	40.0							
9.2	2272	0.8	152.50	16.0	22.0	26.0	30.0	PD/PM 42/12 - 100L/4A	91	164				
10.0	2095	1.0	140.61	16.0	22.0	27.0	30.0	PD 43 - 100L/4A PM 43 - 100L/4A	99	131				
11.9	1766	1.1	118.53	17.0	22.0	28.0	30.0							
12.7	1650	1.0	110.73	17.0	22.0	29.0	30.0	PD 42 - 100L/4A PM 42 - 100L/4A	84	130				
15.6	1349	1.2	90.52	17.0	22.0	29.0	30.0							
18.7	1124	1.4	75.41	16.0	22.0	30.0	30.0							
22.9	919	2.0	61.64	16.0	22.0	30.0	30.0							
27.0	778	2.3	52.23	15.0	22.0	30.0	30.0							
31.3	671	2.4	45.06	15.0	22.0	29.0	30.0							
32.3	650	2.5	43.64	15.0	22.0	29.0	30.0							
34.6	608	2.6	40.79	14.0	22.0	29.0	30.0							
38.3	549	2.5	36.84	14.0	22.0	28.0	30.0							
38.7	542	2.5	36.39	14.0	22.0	28.0	30.0							
43.6	481	2.9	32.31	14.0	22.0	27.0	30.0							
22.0	955	1.1	64.11	9.0	15.0	21.0	20.0	PD 32 - 100L/4A PM 32 - 100L/4A	68	126				
26.6	790	1.1	52.98	9.0	15.0	20.0	20.0							
31.5	668	1.1	44.83	9.0	15.0	20.0	20.0							
33.5	627	1.5	42.05	9.0	15.0	20.0	20.0							
36.5	575	1.1	38.59	9.0	15.0	19.0	20.0							
37.3	563	1.5	37.79	9.0	15.0	19.0	20.0							
44.2	475	1.8	31.90	9.0	15.0	18.0	20.0							
49.2	427	2.0	28.67	9.0	15.0	18.0	20.0							
54.5	385	2.2	25.86	8.0	15.0	17.0	20.0							
59.5	353	2.1	23.69	8.0	15.0	17.0	20.0							
62.9	334	2.4	22.42	8.0	15.0	17.0	20.0							
66.0	318	2.3	21.37	8.0	15.0	17.0	20.0							
70.0	300	2.6	20.15	8.0	15.0	16.0	20.0							
84.7	248	2.6	16.65	8.0	14.0	16.0	20.0							

P ₁ [kW]	n ₂ [Min ⁻¹]	M ₂ [Nm]	f _B	i _{ges}	F _R [kN]	F _A [kN]	F _{R GR} [kN]	F _{A GR} [kN]	Tip / Type	Kg	Sayfa Page mm			
2.20	32.2	652	0.9	43.73	7.0	12.0	12.0	15.0	PD 22 - 100L/4A PM 22 - 100L/4A	53	122			
	38.6	545	0.9	36.57	8.0	12.0	13.0	15.0						
	45.2	465	1.0	31.20	7.0	12.0	13.0	15.0						
	47.6	442	1.1	29.64	7.0	12.0	13.0	15.0						
	52.6	400	1.1	26.81	7.0	12.0	13.0	15.0						
	56.4	372	1.3	24.98	7.0	12.0	14.0	15.0						
	58.8	357	1.2	23.99	7.0	12.0	14.0	15.0						
	64.4	326	1.5	21.89	7.0	12.0	14.0	15.0						
	76.2	276	1.8	18.51	7.0	12.0	14.0	15.0						
	85.2	247	1.9	16.56	7.0	12.0	13.0	15.0						
	106.8	197	2.1	13.20	6.0	12.0	13.0	15.0						
	119.4	176	2.2	11.81	6.0	12.0	12.0	15.0						
	138.8	151	2.4	10.16	6.0	11.0	12.0	15.0						
	156.7	134	2.5	9.00	6.0	11.0	11.0	15.0						
	168.7	125	2.1	8.36	6.0	11.0	11.0	15.0						
	188.5	111	2.2	7.48	5.0	10.0	11.0	15.0						
	219.2	96	2.4	6.43	5.0	10.0	10.0	15.0						
	247.4	85	2.5	5.70	5.0	9.0	10.0	15.0						
	312.5	67	2.8	4.51	5.0	8.0	9.0	15.0						
	58.3	360	0.8	24.17	4.0	6.0	8.0	11.0				PD C13 - 100L/4A PM C13 - 100L/4A	46	116
	75.2	280	0.9	18.76	4.0	6.0	8.0	11.0						
	87.0	241	1.0	16.20	4.0	6.0	8.0	11.0						
	81.9	257	0.9	17.22	3.0	5.0	9.0	7.0				PD 12 - 100L/4A PM 12 - 100L/4A	40	118
	100.1	210	1.0	14.09	3.0	5.0	9.0	7.0						
	120.0	175	1.2	11.75	3.0	5.0	9.0	7.0						
	136.3	154	1.3	10.34	3.0	5.0	9.0	7.0						
	153.9	136	1.4	9.16	3.0	5.0	9.0	7.0						
	171.3	123	1.6	8.23	3.0	5.0	8.0	7.0						
	194.5	108	1.7	7.25	3.0	5.0	8.0	7.0						
	219.7	96	1.9	6.42	2.0	4.0	8.0	7.0						
257.6	82	2.1	5.47	2.0	4.0	7.0	7.0							
295.1	71	1.8	4.78	2.0	4.0	7.0	7.0							
3.00	1.0	28096	2.1	1382.74	-	-	134.0	170.0	PD 113/52 - 100L/4B PM 113/52 - 100L/4B	2180	168			
	1.2	23464	2.6	1154.79	-	-	139.0	170.0						
	1.5	19550	2.7	962.15	-	-	144.0	170.0						
	1.9	14863	2.7	731.47	-	-	147.0	170.0						
	1.0	28790	1.2	1416.90	-	-	117.0	150.0	PD 103/52 - 100L/4B PM 103/52 - 100L/4B	1342	168			
	1.2	23684	1.5	1165.61	-	-	124.0	150.0						
	1.5	18609	1.9	915.84	-	-	129.0	150.0						
	2.0	14065	2.5	692.20	-	-	133.0	150.0						
	2.4	11746	2.7	578.09	-	-	134.0	150.0						
	3.0	9691	3.0	476.93	-	-	135.0	150.0						
	1.0	28806	0.8	1417.68	97.0	102.0	120.0	130.0	PD 93/42 - 100L/4B PM 93/42 - 100L/4B	749	168			
	1.2	23923	1.0	1177.36	97.0	102.0	120.0	130.0						
	1.6	17996	1.3	885.67	94.0	102.0	120.0	130.0						
	2.0	14536	1.7	715.36	93.0	102.0	120.0	130.0						
	2.3	12574	1.9	618.83	90.0	102.0	120.0	130.0						
	3.1	9161	2.6	450.86	85.0	102.0	120.0	130.0						
	3.4	8341	2.9	410.49	84.0	102.0	120.0	130.0						
	2.0	14560	0.8	716.55	74.0	73.0	100.0	100.0	PD 83/32 - 100L/4B PM 83/32 - 100L/4B	431	166			
	2.3	12396	1.0	610.07	74.0	73.0	100.0	100.0						
	2.6	11181	1.1	550.29	74.0	73.0	100.0	100.0	PD 83/42 - 100L/4B PM 83/42 - 100L/4B	447	168			
3.0	9526	1.3	468.82	73.0	73.0	100.0	100.0							
3.6	7851	1.6	386.39	71.0	73.0	100.0	105.0	PD 83 - 100L/4B PM 83 - 100L/4B	405	147				
4.4	6464	2.0	318.11	68.0	73.0	100.0	105.0							
7.0	4081	2.6	200.83	62.0	73.0	100.0	105.0							
3.2	8835	0.8	434.82	43.0	58.0	72.0	80.0	PD 73/22 - 100L/4B PM 73/22 - 100L/4B	295	166				
3.7	7645	0.9	376.24	48.0	58.0	75.0	80.0							

3.00 kW

P ₁ [kW]	n ₂ [Min ⁻¹]	M ₂ [Nm]	f _B	i _{ges}	F _R [kN]	F _A [kN]	F _{R GR} [kN]	F _{A GR} [kN]	Tip / Type	Kg	Sayfa Page mm
3.00	4.2	6875	1.1	338.37	50.0	58.0	76.0	80.0	PD 73 - 100L/4B PM 73 - 100L/4B	280	143
	5.2	5554	1.4	273.32	52.0	58.0	79.0	80.0			
	6.5	4398	1.9	216.45	50.0	58.0	80.0	80.0			
	6.9	4160	1.8	204.72	50.0	58.0	80.0	80.0			
	8.7	3294	1.9	162.12	47.0	58.0	81.0	80.0			
	9.4	3054	2.3	150.32	47.0	58.0	81.0	80.0			
	11.5	2502	2.5	123.12	45.0	58.0	82.0	80.0			
	4.0	7093	0.8	349.07	16.0	47.0	44.0	60.0	PD/PM 63/22 - 100L/4B	222	166
	4.4	6454	0.9	317.64	23.0	47.0	47.0	60.0	PD 63 - 100L/4B PM 63 - 100L/4B	204	139
	5.3	5444	1.1	267.94	30.0	47.0	51.0	60.0			
	5.6	5113	0.9	251.63	31.0	47.0	52.0	60.0			
	6.2	4589	0.9	225.83	34.0	47.0	53.0	60.0			
	6.6	4313	1.1	212.26	35.0	47.0	54.0	60.0			
	8.2	3482	1.6	171.37	38.0	47.0	56.0	60.0			
	8.8	3253	1.8	160.11	38.0	47.0	56.0	60.0			
	11.1	2577	1.8	126.84	40.0	47.0	57.0	60.0			
	12.3	2332	2.1	114.79	40.0	47.0	57.0	60.0			
	15.2	1883	2.1	92.68	38.0	47.0	58.0	60.0			
	18.7	1530	2.4	75.30	36.0	47.0	58.0	60.0			
	17.6	1631	2.5	80.26	37.0	47.0	58.0	60.0	PD/PM 62 - 100L/4B	210	138
	7.0	4121	0.8	202.80	20.0	32.0	37.0	40.0	PD 53 - 100L/4B PM 53 - 100L/4B	141	135
	8.2	3482	0.8	171.36	24.0	32.0	39.0	40.0			
	9.2	3126	1.0	153.85	26.0	32.0	40.0	40.0			
	10.2	2820	1.1	138.78	25.0	32.0	41.0	40.0			
	10.5	2724	1.0	134.05	26.0	32.0	42.0	40.0	PD 52 - 100L/4B PM 52 - 100L/4B	123	134
	14.1	2035	1.1	100.15	25.0	32.0	43.0	40.0			
	15.4	1866	1.5	91.82	24.0	32.0	43.0	40.0			
	17.3	1660	1.1	81.68	24.0	32.0	44.0	40.0			
	20.6	1394	2.1	68.60	23.0	32.0	44.0	40.0			
	25.2	1137	2.3	55.94	22.0	32.0	43.0	40.0			
	29.8	961	2.5	47.27	21.0	32.0	41.0	40.0			
	34.6	829	2.3	40.79	20.0	32.0	40.0	40.0			
	42.2	679	2.4	33.41	19.0	32.0	38.0	40.0			
	11.9	2408	0.8	118.53	14.0	22.0	26.0	30.0			
	13.6	2110	0.9	103.86	15.0	22.0	27.0	30.0			
	15.6	1839	0.9	90.52	15.0	22.0	28.0	30.0	PD 42 - 100L/4B PM 42 - 100L/4B	87	130
	18.7	1532	1.0	75.41	15.0	22.0	29.0	30.0			
	22.9	1253	1.4	61.64	15.0	22.0	30.0	30.0			
	27.0	1061	1.7	52.23	14.0	22.0	30.0	30.0			
	31.3	916	1.7	45.06	14.0	22.0	29.0	30.0			
	32.3	887	1.8	43.64	14.0	22.0	28.0	30.0			
	34.6	829	1.9	40.79	14.0	22.0	28.0	30.0			
	38.3	748	1.8	36.84	13.0	22.0	27.0	30.0			
	38.7	739	1.9	36.39	13.0	22.0	27.0	30.0			
	43.6	656	2.1	32.31	13.0	22.0	27.0	30.0			
	53.4	537	2.1	26.41	12.0	22.0	25.0	30.0			
	63.0	455	2.1	22.38	12.0	22.0	24.0	30.0			
65.7	436	2.3	21.46	12.0	22.0	24.0	30.0				
77.6	369	2.3	18.18	11.0	21.0	23.0	30.0				
92.8	309	2.3	15.19	11.0	20.0	22.0	30.0				
111.3	257	2.3	12.67	10.0	19.0	21.0	30.0				

P ₁ [kW]	n ₂ [Min ⁻¹]	M ₂ [Nm]	f _B	i _{ges}	F _R [kN]	F _A [kN]	F _{R GR} [kN]	F _{A GR} [kN]	Tip / Type	Kg	Sayfa Page mm
3.00	33.5	854	1.1	42.05	8.0	15.0	19.0	20.0	PD 32 - 100L/4B PM 32 - 100L/4B	71	126
	37.3	768	1.1	37.79	8.0	15.0	18.0	20.0			
	44.2	648	1.4	31.90	8.0	15.0	18.0	20.0			
	49.2	582	1.5	28.67	8.0	15.0	17.0	20.0			
	54.5	525	1.6	25.86	8.0	15.0	17.0	20.0			
	59.5	481	1.6	23.69	8.0	14.0	17.0	20.0			
	62.9	456	1.8	22.42	8.0	14.0	16.0	20.0			
	66.0	434	1.7	21.37	8.0	14.0	16.0	20.0			
	70.0	409	1.9	20.15	8.0	14.0	16.0	20.0			
	84.7	338	1.9	16.65	7.0	13.0	15.0	20.0			
	100.1	286	1.9	14.09	7.0	13.0	15.0	20.0			
	124.2	231	2.1	11.35	7.0	12.0	14.0	20.0			
	144.3	199	2.1	9.77	6.0	11.0	13.0	20.0			
	170.1	168	1.9	8.29	6.0	11.0	13.0	19.0			
	211.0	136	2.1	6.68	6.0	10.0	12.0	18.0			
	249.2	115	2.2	5.66	6.0	9.0	11.0	18.0			
	47.6	602	0.8	29.64	7.0	12.0	12.0	15.0	PD 22 - 100L/4B PM 22 - 100L/4B	56	122
	52.6	545	0.8	26.81	7.0	12.0	13.0	15.0			
	56.4	508	1.0	24.98	7.0	12.0	13.0	15.0			
	58.8	487	0.9	23.99	7.0	12.0	13.0	15.0			
	64.4	445	1.1	21.89	7.0	12.0	13.0	15.0			
	76.2	376	1.3	18.51	6.0	12.0	13.0	15.0			
	85.2	336	1.4	16.56	6.0	12.0	13.0	15.0			
	106.8	268	1.5	13.20	6.0	12.0	12.0	15.0			
	119.4	240	1.6	11.81	6.0	11.0	12.0	15.0			
	138.8	206	1.7	10.16	6.0	11.0	12.0	15.0			
	156.7	183	1.8	9.00	6.0	10.0	11.0	15.0			
	168.7	170	1.5	8.36	5.0	10.0	11.0	15.0			
	188.5	152	1.6	7.48	5.0	10.0	11.0	15.0			
	219.2	131	1.7	6.43	5.0	9.0	10.0	15.0			
	247.4	116	1.8	5.70	5.0	9.0	10.0	15.0			
	312.5	92	2.0	4.51	5.0	8.0	9.0	15.0			
	120.0	239	0.9	11.75	2.0	4.0	9.0	7.0	PD 12 - 100L/4B PM 12 - 100L/4B	43	118
136.3	210	0.9	10.34	2.0	4.0	9.0	7.0				
153.9	186	1.0	9.16	2.0	4.0	8.0	7.0				
171.3	167	1.1	8.23	2.0	4.0	8.0	7.0				
194.5	147	1.3	7.25	2.0	4.0	8.0	7.0				
219.7	130	1.4	6.42	2.0	4.0	8.0	7.0				
257.6	111	1.5	5.47	2.0	4.0	7.0	7.0				
295.1	97	1.3	4.78	2.0	4.0	7.0	7.0				
4.00	1.0	36937	1.6	1382.74	-	-	118.0	170.0			
1.2	30848	1.9	1154.79	-	-	133.0	170.0				
1.5	25702	2.3	962.15	-	-	138.0	170.0				
2.0	19540	3.1	731.47	-	-	144.0	170.0				
2.4	16121	3.3	603.47	-	-	146.0	170.0				
1.0	37850	0.9	1416.90	-	-	98.0	150.0	PD 103/52 - 112M/4B PM 103/52 - 112M/4B	1348	168	
1.2	31137	1.1	1165.61	-	-	111.0	150.0				
1.6	24465	1.4	915.84	-	-	124.0	150.0				
2.1	18491	1.9	692.20	-	-	130.0	150.0				
2.5	15443	2.3	578.09	-	-	132.0	150.0				
3.0	12740	2.7	476.93	-	-	134.0	150.0				
1.2	31451	0.8	1177.36	82.0	102.0	120.0	130.0	PD 93/42 - 112M/4B PM 93/42 - 112M/4B	755	168	
1.6	23659	1.0	885.67	83.0	102.0	120.0	130.0				
2.0	19110	1.3	715.36	84.0	102.0	120.0	130.0				
2.3	16531	1.5	618.83	83.0	102.0	120.0	130.0				
3.2	12044	2.0	450.86	79.0	102.0	120.0	130.0				
3.5	10966	2.2	410.49	78.0	102.0	120.0	130.0	PD 93/52 - 112M/4B PM 93/52 - 112M/4B	784	168	
4.9	7859	3.1	294.19	73.0	102.0	120.0	130.0				
2.3	16297	0.7	610.07	64.0	73.0	100.0	100.0	PD/PM 83/32 - 112M/4B	438	166	
2.6	14700	0.8	550.29	64.0	73.0	100.0	100.0	PD 83/42 - 112M/4B PM 83/42 - 112M/4B	453	168	
3.1	12524	1.0	468.82	64.0	73.0	100.0	100.0				

P ₁ [kW]	n ₂ [Min ⁻¹]	M ₂ [Nm]	f _B	i _{ges}	F _R [kN]	F _A [kN]	F _{R GR} [kN]	F _{A GR} [kN]	Tip / Type	Kg	Sayfa Page mm
4.00	3.7	10322	1.2	386.39	65.0	73.0	100.0	105.0	PD 83 - 112M/4B PM 83 - 112M/4B	413	147
	4.5	8498	1.5	318.11	63.0	73.0	100.0	105.0			
	7.1	5365	2.0	200.83	59.0	73.0	100.0	105.0			
	9.9	3844	2.0	143.91	55.0	73.0	100.0	105.0			
	12.1	3165	2.0	118.48	53.0	73.0	100.0	105.0			
	13.9	2755	2.1	103.13	51.0	73.0	100.0	105.0			
	15.8	2425	2.2	90.79	49.0	73.0	99.0	105.0			
	18.9	2022	2.3	75.70	47.0	73.0	94.0	105.0			
	21.9	1741	2.4	65.16	45.0	73.0	91.0	105.0			
	24.9	1531	2.2	57.32	44.0	73.0	88.0	105.0			
	29.9	1277	2.3	47.79	41.0	68.0	83.0	105.0			
	32.9	1162	2.3	43.52	40.0	66.0	81.0	105.0			
	39.9	957	2.3	35.83	38.0	61.0	77.0	105.0			
	46.4	824	2.4	30.84	36.0	57.0	73.0	105.0			
	4.2	9039	0.8	338.37	43.0	58.0	72.0	80.0	PD 73 - 112M/4B PM 73 - 112M/4B	288	143
	5.2	7301	1.0	273.32	47.0	58.0	76.0	80.0			
	6.6	5782	1.4	216.45	46.0	58.0	78.0	80.0			
	7.0	5469	1.4	204.72	46.0	58.0	79.0	80.0			
	8.8	4331	1.4	162.12	44.0	58.0	80.0	80.0			
	9.5	4015	1.7	150.32	44.0	58.0	81.0	80.0			
	11.6	3289	1.8	123.12	42.0	58.0	81.0	80.0			
	13.4	2846	2.0	106.53	41.0	58.0	82.0	80.0			
	15.4	2486	2.0	93.05	40.0	58.0	82.0	80.0			
	18.2	2104	1.8	78.75	39.0	58.0	82.0	80.0			
	21.0	1820	2.0	68.14	37.0	58.0	79.0	80.0			
	24.0	1590	2.1	59.52	36.0	58.0	77.0	80.0			
	26.8	1427	2.0	53.42	35.0	58.0	74.0	80.0			
	30.6	1246	2.1	46.66	34.0	58.0	72.0	80.0			
	5.3	7157	0.8	267.94	15.0	47.0	44.0	60.0	PD 63 - 112M/4B PM 63 - 112M/4B	210	139
	6.7	5670	0.8	212.26	28.0	47.0	50.0	60.0			
	8.3	4578	1.2	171.37	34.0	47.0	53.0	60.0			
	8.9	4277	1.3	160.11	35.0	47.0	54.0	60.0			
	11.3	3388	1.4	126.84	38.0	47.0	56.0	60.0			
	12.5	3066	1.6	114.79	37.0	47.0	57.0	60.0			
	15.4	2476	1.6	92.68	36.0	47.0	57.0	60.0			
	19.0	2012	1.8	75.30	34.0	47.0	58.0	60.0			
	19.5	1961	1.7	73.42	34.0	47.0	58.0	60.0			
	24.0	1594	1.8	59.65	33.0	47.0	58.0	60.0			
	28.0	1363	1.9	51.01	31.0	47.0	58.0	60.0			
	33.7	1133	1.8	42.41	30.0	47.0	58.0	60.0			
	17.8	2144	1.9	80.26	35.0	47.0	58.0	60.0	PD 62 - 112M/4B PM 62 - 112M/4B	218	138
	21.8	1749	1.9	65.45	33.0	47.0	58.0	60.0			
	9.3	4110	0.8	153.85	20.0	32.0	37.0	40.0	PD 53 - 112M/4B PM 53 - 112M/4B	148	135
	10.3	3707	0.9	138.78	22.0	32.0	38.0	40.0			
	12.2	3133	0.9	117.27	22.0	32.0	40.0	40.0			
	15.6	2453	1.1	91.82	22.0	32.0	42.0	40.0	PD 52 - 112M/4B PM 52 - 112M/4B	129	134
17.5	2182	0.8	81.68	22.0	32.0	43.0	40.0				
20.8	1832	1.6	68.60	21.0	32.0	43.0	40.0				
25.6	1494	1.7	55.94	20.0	32.0	42.0	40.0				
30.3	1263	1.9	47.27	20.0	32.0	40.0	40.0				
35.1	1090	2.3	40.79	19.0	32.0	39.0	40.0				
42.8	892	2.6	33.41	19.0	32.0	37.0	40.0				
46.9	814	2.5	30.47	18.0	32.0	36.0	40.0				
16.5	2318	0.9	86.78	12.0	22.0	26.0	30.0	PD/PM 43 - 112M/4B	108	131	

P ₁ [kW]	n ₂ [Min ⁻¹]	M ₂ [Nm]	f _B	i _{ges}	F _R [kN]	F _A [kN]	F _{R GR} [kN]	F _{A GR} [kN]	Tip / Type	Kg	Sayfa Page mm			
4.00	19.0	2014	0.8	75.41	13.0	22.0	27.0	30.0	PD 42 - 112M/4B PM 42 - 112M/4B	93	130			
	23.2	1647	1.1	61.64	13.0	22.0	28.0	30.0						
	27.4	1395	1.3	52.23	13.0	22.0	28.0	30.0						
	31.7	1204	1.3	45.06	13.0	22.0	28.0	30.0						
	32.8	1166	1.4	43.64	13.0	22.0	27.0	30.0						
	35.1	1090	1.4	40.79	13.0	22.0	27.0	30.0						
	38.8	984	1.4	36.84	12.0	22.0	27.0	30.0						
	39.3	972	1.4	36.39	12.0	22.0	26.0	30.0						
	44.3	863	1.9	32.31	12.0	22.0	26.0	30.0						
	54.1	706	2.4	26.41	12.0	22.0	25.0	30.0						
	63.9	598	2.4	22.38	11.0	21.0	23.0	30.0						
	66.6	573	2.6	21.46	11.0	21.0	23.0	30.0						
	78.7	486	2.6	18.18	11.0	20.0	22.0	30.0						
	94.1	406	2.6	15.19	10.0	19.0	21.0	30.0						
	34.0	1123	0.8	42.05	7.0	13.0	18.0	20.0				PD 32 - 112M/4B PM 32 - 112M/4B	78	126
	37.8	1009	0.8	37.79	7.0	13.0	17.0	20.0						
	44.8	852	1.0	31.90	7.0	13.0	17.0	20.0						
	49.9	766	1.1	28.67	7.0	13.0	17.0	20.0						
	55.3	691	1.2	25.86	7.0	13.0	16.0	20.0						
	60.4	633	1.3	23.69	7.0	13.0	16.0	20.0						
	63.8	599	1.3	22.42	7.0	13.0	16.0	20.0						
	66.9	571	1.3	21.37	7.0	13.0	16.0	20.0						
	71.0	538	1.5	20.15	7.0	13.0	15.0	20.0						
	85.9	445	1.9	16.65	7.0	12.0	15.0	20.0						
	101.5	376	2.1	14.09	7.0	12.0	14.0	20.0						
	125.9	303	2.4	11.35	6.0	11.0	14.0	20.0						
	146.3	261	2.4	9.77	6.0	11.0	13.0	20.0						
	172.5	221	2.1	8.29	6.0	10.0	12.0	19.0						
	214.0	179	2.4	6.68	6.0	9.0	12.0	18.0						
	252.7	151	2.5	5.66	5.0	9.0	11.0	17.0						
	65.3	585	0.8	21.89	6.0	11.0	12.0	15.0	PD 22 - 112M/4B PM 22 - 112M/4B	63	122			
	77.3	494	1.0	18.51	6.0	11.0	13.0	15.0						
	86.4	442	1.1	16.56	6.0	11.0	13.0	15.0						
	108.3	353	1.1	13.20	5.0	10.0	12.0	15.0						
	121.1	316	1.2	11.81	5.0	10.0	12.0	15.0						
	140.8	271	1.3	10.16	5.0	10.0	11.0	15.0						
	158.9	240	1.4	9.00	5.0	10.0	11.0	15.0						
	171.0	223	1.1	8.36	5.0	9.0	11.0	15.0						
	191.2	200	1.2	7.48	5.0	9.0	10.0	15.0						
	222.4	172	1.3	6.43	5.0	9.0	10.0	15.0						
	250.9	152	1.4	5.70	5.0	8.0	10.0	15.0						
	317.0	121	1.5	4.51	4.0	8.0	9.0	15.0						
	156.1	245	0.8	9.16	2.0	3.0	8.0	7.0	PD 12 - 112M/4B PM 12 - 112M/4B	50	118			
	173.8	220	0.9	8.23	2.0	3.0	8.0	7.0						
197.3	194	1.0	7.25	2.0	3.0	8.0	7.0							
222.8	171	1.1	6.42	2.0	3.0	7.0	7.0							
261.3	146	1.2	5.47	2.0	3.0	7.0	7.0							
299.2	128	1.0	4.78	2.0	3.0	7.0	7.0							
5.50	1.0	50262	1.2	1382.74	-	-	77.0	170.0	PD 113/52 - 132S/4C PM 113/52 - 132S/4C	2203	168			
	1.3	41976	1.4	1154.79	-	-	113.0	170.0						
	1.5	34974	1.7	962.15	-	-	124.0	170.0						
	2.0	26589	2.3	731.47	-	-	137.0	170.0						
	2.4	21936	2.7	603.47	-	-	141.0	170.0						
	1.2	42369	0.8	1165.61	-	-	81.0	150.0	PD 103/52 - 132S/4C PM 103/52 - 132S/4C	1365	168			
	1.6	33290	1.1	915.84	-	-	109.0	150.0						
	2.1	25161	1.4	692.20	-	-	122.0	150.0						
	2.5	21013	1.7	578.09	-	-	127.0	150.0						
	3.0	17336	2.0	476.93	-	-	130.0	150.0						
	3.9	13310	2.6	366.18	-	-	133.0	150.0						
	2.0	26003	0.9	715.36	70.0	102.0	120.0	130.0	PD 93/42 - 132S/4C PM 93/42 - 132S/4C	772	168			
	2.3	22494	1.1	618.83	71.0	102.0	120.0	130.0						
	3.2	16389	1.5	450.86	71.0	102.0	120.0	130.0	PD/PM 93/52 - 132S/4C	801	168			
	3.5	14921	1.6	410.49	71.0	102.0	120.0	130.0						

P ₁ [kW]	n ₂ [Min ⁻¹]	M ₂ [Nm]	f _B	i _{ges}	F _R [kN]	F _A [kN]	F _{R GR} [kN]	F _{A GR} [kN]	Tip / Type	Kg	Sayfa Page mm
5.50	4.1	12801	2.0	352.16	86.0	102.0	120.0	130.0	PD 93 - 132S/4C PM 93 - 132S/4C	730	151
	5.0	10576	2.3	290.94	82.0	102.0	120.0	130.0			
	7.1	7439	3.0	204.66	77.0	102.0	120.0	130.0			
	8.3	6362	3.4	175.03	75.0	102.0	120.0	130.0			
	3.7	14045	0.9	386.39	55.0	73.0	100.0	105.0	PD 83 - 132S/4C PM 83 - 132S/4C	428	147
	4.5	11563	1.1	318.11	55.0	73.0	100.0	105.0			
	4.9	10684	1.2	293.92	56.0	73.0	100.0	105.0			
	6.0	8796	1.5	241.98	55.0	73.0	100.0	105.0			
	7.2	7300	1.5	200.83	54.0	73.0	100.0	105.0			
	7.8	6745	1.9	185.56	54.0	73.0	100.0	105.0			
	9.5	5553	2.4	152.77	52.0	73.0	100.0	105.0			
	10.0	5231	2.4	143.91	52.0	73.0	100.0	105.0			
11.5	4553	2.7	125.27	50.0	73.0	100.0	105.0				
	5.3	9935	0.8	273.32	38.0	58.0	69.0	80.0	PD 73 - 132S/4C PM 73 - 132S/4C	303	143
	6.7	7868	1.1	216.45	40.0	58.0	74.0	80.0			
	7.1	7441	1.0	204.72	40.0	58.0	75.0	80.0			
	8.9	5893	1.1	162.12	40.0	58.0	78.0	80.0			
	9.6	5464	1.4	150.32	40.0	58.0	79.0	80.0			
	11.7	4475	1.7	123.12	39.0	58.0	80.0	80.0			
	13.6	3872	1.9	106.53	38.0	58.0	81.0	80.0			
	15.5	3382	2.2	93.05	37.0	58.0	81.0	80.0			
18.3	2863	2.6	78.75	36.0	58.0	81.0	80.0				
	8.4	6229	0.9	171.37	24.0	47.0	48.0	60.0	PD 63 - 132S/4C PM 63 - 132S/4C	227	139
	9.0	5820	1.0	160.11	27.0	47.0	49.0	60.0			
	11.4	4611	1.0	126.84	33.0	47.0	53.0	60.0			
	12.6	4173	1.4	114.79	34.0	47.0	55.0	60.0			
	15.6	3369	1.8	92.68	33.0	47.0	56.0	60.0			
	19.2	2737	2.2	75.30	32.0	47.0	57.0	60.0			
	19.7	2669	2.1	73.42	32.0	47.0	57.0	60.0			
	24.2	2168	2.5	59.65	31.0	47.0	58.0	60.0			
	28.3	1854	2.7	51.01	30.0	47.0	58.0	60.0			
	34.1	1542	2.7	42.41	29.0	47.0	57.0	60.0			
39.8	1318	2.9	36.27	28.0	47.0	55.0	60.0				
	18.0	2917	1.4	80.26	33.0	47.0	57.0	60.0	PD 62 - 132S/4C PM 62 - 132S/4C	233	138
	22.1	2379	1.4	65.45	31.0	47.0	57.0	60.0			
	23.7	2219	2.0	61.05	31.0	47.0	58.0	60.0			
	29.0	1810	2.2	49.79	30.0	47.0	58.0	60.0			
	36.6	1434	2.2	39.44	28.0	47.0	56.0	60.0			
	15.7	3338	0.8	91.82	19.0	32.0	40.0	40.0	PD 52 - 132S/4C PM 52 - 132S/4C	146	134
	21.1	2493	1.2	68.60	19.0	32.0	42.0	40.0			
	25.8	2034	1.3	55.94	19.0	32.0	41.0	40.0			
	28.1	1870	1.7	51.45	19.0	32.0	40.0	40.0			
	30.6	1718	1.4	47.27	18.0	32.0	39.0	40.0			
	34.4	1525	2.1	41.96	18.0	32.0	38.0	40.0			
	35.4	1483	1.7	40.79	18.0	32.0	38.0	40.0			
	40.8	1289	2.1	35.45	17.0	32.0	37.0	40.0			
	43.3	1214	1.9	33.41	18.0	32.0	36.0	40.0			
	47.4	1108	2.6	30.47	17.0	32.0	36.0	40.0			
57.9	907	2.9	24.96	16.0	31.0	34.0	40.0				
	23.4	2241	0.8	61.64	11.0	21.0	26.0	30.0	PD 42 - 132S/4C PM 42 - 132S/4C	110	130
	27.7	1899	1.0	52.23	11.0	21.0	27.0	30.0			
	32.1	1638	1.0	45.06	11.0	22.0	26.0	30.0			
	33.1	1586	1.0	43.64	11.0	21.0	26.0	30.0			
	35.4	1483	1.0	40.79	11.0	22.0	26.0	30.0			
	37.7	1394	1.4	38.35	11.0	21.0	25.0	30.0			
	39.2	1339	1.0	36.84	11.0	22.0	25.0	30.0			
	39.7	1323	1.0	36.39	11.0	21.0	25.0	30.0			
	45.1	1165	1.5	32.04	11.0	21.0	25.0	30.0			
	54.1	971	1.6	26.72	11.0	20.0	24.0	30.0			
	54.7	960	1.9	26.41	11.0	21.0	24.0	30.0			
	64.6	813	2.1	22.38	11.0	20.0	23.0	30.0			
	67.3	780	2.2	21.46	11.0	20.0	23.0	30.0			
	79.5	661	2.7	18.18	10.0	19.0	22.0	30.0			
	95.1	552	2.7	15.19	10.0	18.0	21.0	30.0			
	114.1	460	2.8	12.67	9.0	17.0	20.0	30.0			

P ₁ [kW]	n ₂ [Min ⁻¹]	M ₂ [Nm]	f _B	i _{ges}	F _R [kN]	F _A [kN]	F _{R GR} [kN]	F _{A GR} [kN]	Tip / Type	Kg	Sayfa Page mm
5.50	45.3	1160	0.8	31.90	6.0	10.0	16.0	20.0	PD 32 - 132S/4C PM 32 - 132S/4C	94	126
	50.4	1042	0.8	28.67	6.0	11.0	16.0	20.0			
	55.9	940	0.9	25.86	6.0	11.0	15.0	20.0			
	61.0	861	0.9	23.69	6.0	11.0	15.0	20.0			
	64.5	815	1.0	22.42	6.0	11.0	15.0	20.0			
	67.6	777	0.9	21.37	6.0	11.0	15.0	20.0			
	71.7	732	1.1	20.15	6.0	11.0	15.0	20.0			
	86.8	605	1.4	16.65	6.0	11.0	14.0	20.0			
	102.6	512	1.7	14.09	6.0	10.0	14.0	20.0			
	127.3	413	2.0	11.35	6.0	10.0	13.0	19.0			
	147.8	355	2.4	9.77	6.0	10.0	13.0	19.0			
	174.3	301	2.2	8.29	5.0	9.0	12.0	18.0			
	216.2	243	2.5	6.68	5.0	9.0	11.0	17.0			
	255.4	206	2.7	5.66	5.0	8.0	11.0	17.0			
322.4	163	2.8	4.48	5.0	8.0	10.0	16.0				
7.50	1.0	68302	0.9	1382.74	-	-	36.0	170.0	PD 113/52 - 132M/4B PM 113/52 - 132M/4B	2214	168
	1.3	57043	1.1	1154.79	-	-	65.0	170.0			
	1.5	47527	1.3	962.15	-	-	94.0	170.0			
	2.0	36132	1.7	731.47	-	-	122.0	170.0			
	2.4	29809	2.0	603.47	-	-	132.0	170.0			
	1.6	45239	0.8	915.84	-	-	77.0	150.0	PD 103/52 - 132M/4B PM 103/52 - 132M/4B	1376	168
	2.1	34192	1.0	692.20	-	-	107.0	150.0			
	2.5	28556	1.2	578.09	-	-	117.0	150.0			
	3.0	23559	1.5	476.93	-	-	124.0	150.0			
	4.0	18088	1.9	366.18	-	-	129.0	150.0			
	4.1	17655	2.0	357.40	-	-	130.0	150.0	PD 103 - 132M/4B PM 103 - 132M/4B	1305	155
	4.4	16431	2.3	332.64	-	-	131.0	150.0			
	5.1	13972	2.4	282.85	-	-	133.0	150.0			
	5.5	13004	2.5	263.25	-	-	134.0	150.0			
	2.3	30568	0.8	618.83	56.0	102.0	120.0	130.0	PD 93/42 - 132M/4B PM 93/42 - 132M/4B	783	168
	3.2	22271	1.1	450.86	60.0	102.0	120.0	130.0			
	3.5	20277	1.2	410.49	61.0	102.0	120.0	130.0	PD/PM 93/52 - 132M/4B	812	168
	4.1	17396	1.5	352.16	78.0	102.0	120.0	130.0	PD 93 - 132M/4B PM 93 - 132M/4B	741	151
	5.0	14372	1.7	290.94	75.0	102.0	120.0	130.0			
	7.1	10109	2.2	204.66	72.0	102.0	120.0	130.0			
	8.3	8646	2.5	175.03	70.0	102.0	120.0	130.0			
	10.0	7143	2.5	144.60	67.0	102.0	120.0	130.0			
	10.7	6701	2.7	135.66	67.0	102.0	120.0	130.0			
	4.9	14519	0.9	293.92	46.0	73.0	100.0	105.0	PD 83 - 132M/4B PM 83 - 132M/4B	439	147
	6.0	11953	1.1	241.98	47.0	73.0	100.0	105.0			
	7.8	9166	1.4	185.56	48.0	73.0	100.0	105.0			
	9.5	7546	1.7	152.77	47.0	73.0	100.0	105.0			
	10.1	7109	1.8	143.91	47.0	73.0	100.0	105.0			
	12.2	5853	2.1	118.48	46.0	73.0	100.0	105.0			
	14.1	5094	2.4	103.13	45.0	73.0	97.0	105.0			
	16.0	4485	2.6	90.79	44.0	73.0	95.0	105.0			
	19.2	3740	2.7	75.70	43.0	73.0	91.0	105.0			
20.1	3565	2.2	72.17	43.0	73.0	-	-	PD/PM 82 - 132M/4B			
8.9	8008	0.8	162.12	33.0	58.0	74.0	80.0	PD 73 - 132M/4B PM 73 - 132M/4B	314	143	
9.6	7425	1.0	150.32	34.0	58.0	75.0	80.0				
11.8	6082	1.2	123.12	34.0	58.0	78.0	80.0				
13.6	5262	1.4	106.53	34.0	58.0	79.0	80.0				
15.6	4596	1.6	93.05	34.0	58.0	80.0	80.0				
18.4	3890	1.9	78.75	33.0	58.0	78.0	80.0				
21.3	3366	2.1	68.14	33.0	58.0	76.0	80.0				
24.4	2940	2.3	59.52	32.0	57.0	73.0	80.0				
27.1	2639	2.2	53.42	32.0	55.0	71.0	80.0				
20.8	3448	1.7	69.80	33.0	58.0	76.0	80.0				PD 72 - 132M/4B PM 72 - 132M/4B
25.5	2811	2.0	56.90	32.0	56.0	73.0	80.0				

P ₁ [kW]	n ₂ [Min ⁻¹]	M ₂ [Nm]	f _B	i _{ges}	F _R [kN]	F _A [kN]	F _{R GR} [kN]	F _{A GR} [kN]	Tip / Type	Kg	Sayfa Page mm
7.50	12.6	5670	1.0	114.79	29.0	47.0	50.0	60.0	PD 63 - 132M/4B PM 63 - 132M/4B	238	139
	15.6	4578	1.3	92.68	29.0	47.0	53.0	60.0			
	19.3	3720	1.6	75.30	29.0	47.0	55.0	60.0			
	19.7	3627	1.5	73.42	29.0	47.0	56.0	60.0			
	24.3	2947	1.9	59.65	28.0	47.0	57.0	60.0			
	28.4	2520	2.0	51.01	28.0	47.0	57.0	60.0			
	34.2	2095	2.2	42.41	27.0	46.0	56.0	60.0			
	40.0	1792	2.2	36.27	26.0	44.0	54.0	60.0			
	46.9	1526	2.3	30.90	25.0	42.0	52.0	60.0			
	50.6	1416	2.1	28.66	25.0	41.0	51.0	60.0			
	23.8	3016	1.5	61.05	29.0	47.0	57.0	60.0	PD 62 - 132M/4B PM 62 - 132M/4B	244	138
	29.1	2459	1.6	49.79	28.0	47.0	57.0	60.0			
	36.8	1948	1.6	39.44	26.0	45.0	55.0	60.0			
	48.5	1477	2.3	29.89	25.0	42.0	52.0	60.0			
	55.7	1285	2.4	26.02	25.0	40.0	50.0	60.0			
	26.1	2744	0.8	55.55	17.0	32.0	39.0	40.0	PD 52 - 132M/4B PM 52 - 132M/4B	157	134
	28.2	2541	1.3	51.45	17.0	32.0	38.0	40.0			
	34.6	2073	1.5	41.96	16.0	32.0	37.0	40.0			
	35.5	2015	1.2	40.79	17.0	31.0	37.0	40.0			
	40.9	1751	1.5	35.45	16.0	31.0	35.0	40.0			
	43.4	1650	1.4	33.41	16.0	30.0	35.0	40.0			
	47.6	1505	1.9	30.47	16.0	31.0	35.0	40.0			
	58.1	1233	2.1	24.96	15.0	29.0	33.0	40.0			
	71.2	1005	2.1	20.36	15.0	27.0	31.0	40.0			
	76.9	932	2.4	18.86	15.0	27.0	31.0	40.0			
	35.5	2015	0.8	40.79	9.0	17.0	24.0	30.0	PD 42 - 132M/4B PM 42 - 132M/4B	121	130
	37.8	1894	1.1	38.35	9.0	17.0	24.0	30.0			
	45.3	1583	1.1	32.04	9.0	17.0	23.0	30.0			
	54.3	1320	1.2	26.72	9.0	17.0	22.0	30.0			
	54.9	1305	1.4	26.41	10.0	18.0	23.0	30.0			
	64.8	1105	1.5	22.38	9.0	17.0	22.0	30.0			
	67.6	1060	1.6	21.46	10.0	17.0	22.0	30.0			
	79.8	898	2.0	18.18	9.0	17.0	21.0	30.0			
	95.4	750	2.0	15.19	9.0	16.0	20.0	30.0			
	114.5	626	2.0	12.67	9.0	15.0	19.0	30.0			
	133.9	535	2.1	10.83	9.0	15.0	19.0	30.0			
	157.1	456	2.3	9.23	8.0	14.0	18.0	30.0			
	174.0	412	2.0	8.33	8.0	14.0	17.0	29.0			
	203.5	352	2.2	7.13	8.0	13.0	17.0	28.0			
	238.8	300	2.3	6.07	8.0	13.0	16.0	27.0			
72.0	995	0.8	20.15	5.0	8.0	14.0	19.0	PD 32 - 132M/4B PM 32 - 132M/4B	105	126	
87.1	822	1.0	16.65	5.0	8.0	13.0	19.0				
102.9	696	1.2	14.09	5.0	8.0	13.0	19.0				
127.7	561	1.5	11.35	5.0	8.0	13.0	18.0				
148.4	483	1.7	9.77	5.0	8.0	12.0	18.0				
174.9	410	1.7	8.29	5.0	8.0	12.0	17.0				
217.0	330	1.8	6.68	5.0	8.0	11.0	17.0				
256.3	279	2.0	5.66	5.0	7.0	11.0	16.0				
323.6	221	2.1	4.48	5.0	7.0	10.0	15.0				
9.20	1.3	69973	0.9	1154.79	-	-	18.0				170.0
	1.5	58300	1.0	962.15	-	-	42.0	170.0			
	2.0	44322	1.4	731.47	-	-	105.0	170.0			
	2.4	36566	1.6	603.47	-	-	121.0	170.0			
	3.0	29075	2.1	479.85	-	-	133.0	170.0			
	4.0	22008	2.3	363.21	-	-	141.0	170.0			
	4.6	18919	2.6	312.23	-	-	144.0	170.0			
	2.1	41943	0.8	692.20	-	-	87.0	150.0	PD 103/52 - 132M/4 PM 103/52 - 132M/4	1376	168
	2.5	35029	1.0	578.09	-	-	105.0	150.0			
	3.0	28899	1.2	476.93	-	-	116.0	150.0			
	4.0	22188	1.6	366.18	-	-	126.0	150.0			
	4.1	21656	1.6	357.40	-	-	126.0	150.0	PD 103 - 132M/4 PM 103 - 132M/4	1305	155
	4.4	20156	1.8	332.64	-	-	128.0	150.0			
	5.1	17139	1.9	282.85	-	-	130.0	150.0			
	5.5	15951	2.1	263.25	-	-	131.0	150.0			
	8.0	10948	3.2	180.68	-	-	135.0	150.0			

P ₁ [kW]	n ₂ [Min ⁻¹]	M ₂ [Nm]	f _B	i _{ges}	F _R [kN]	F _A [kN]	F _{R GR} [kN]	F _{A GR} [kN]	Tip / Type	Kg	Sayfa Page mm
9.20	3.2	27319	0.9	450.86	51.0	102.0	120.0	130.0	PD\PM 93/42 - 132M/4	783	168
	3.5	24873	1.0	410.49	52.0	102.0	120.0	130.0	PD\PM 93/52 - 132M/4	812	168
	4.1	21338	1.2	352.16	70.0	102.0	120.0	130.0	PD 93 - 132M/4 PM 93 - 132M/4	741	151
	5.0	17629	1.4	290.94	69.0	102.0	120.0	130.0			
	7.1	12401	1.8	204.66	68.0	102.0	120.0	130.0			
	8.3	10606	2.4	175.03	67.0	102.0	120.0	130.0			
	10.0	8762	2.7	144.60	64.0	102.0	120.0	130.0			
	10.7	8220	3.1	135.66	64.0	102.0	120.0	130.0			
	12.6	6999	3.6	115.51	62.0	102.0	117.0	130.0			
	14.4	6101	3.9	100.70	61.0	102.0	115.0	130.0			
	6.0	14662	0.9	241.98	39.0	73.0	100.0	105.0	PD 83 - 132M/4 PM 83 - 132M/4	439	147
	7.8	11243	1.1	185.56	42.0	73.0	100.0	105.0			
	9.5	9257	1.4	152.77	42.0	73.0	100.0	105.0			
	10.1	8720	1.4	143.91	43.0	73.0	100.0	105.0			
	11.6	7590	1.6	125.27	43.0	73.0	98.0	105.0			
	14.1	6249	1.9	103.13	42.0	73.0	95.0	105.0			
	16.0	5501	2.2	90.79	41.0	73.0	92.0	105.0			
	19.2	4587	2.6	75.70	41.0	70.0	89.0	105.0			
	22.3	3948	2.9	65.16	40.0	67.0	86.0	105.0			
	25.3	3473	3.3	57.32	39.0	65.0	83.0	105.0			
	20.1	4373	1.8	72.17	41.0	70.0	-	-	PD 82 - 132M/4 PM 82 - 132M/4	435	146
	24.4	3600	1.8	59.41	39.0	66.0	-	-			
	9.6	9108	0.8	150.32	29.0	58.0	71.0	80.0	PD 73 - 132M/4 PM 73 - 132M/4	314	143
	11.8	7460	1.0	123.12	31.0	58.0	75.0	80.0			
	13.6	6455	1.2	106.53	31.0	58.0	77.0	80.0			
	15.6	5638	1.3	93.05	31.0	58.0	78.0	80.0			
	18.4	4772	1.6	78.75	31.0	56.0	76.0	80.0			
	21.3	4129	1.7	68.14	31.0	55.0	74.0	80.0			
	24.4	3607	2.0	59.52	30.0	53.0	72.0	80.0			
	27.1	3237	2.2	53.42	30.0	52.0	70.0	80.0			
	31.1	2827	2.5	46.66	29.0	50.0	68.0	80.0			
	39.2	2239	3.0	36.95	28.0	47.0	64.0	80.0			
	20.8	4229	1.4	69.80	31.0	56.0	74.0	80.0	PD 72 - 132M/4 PM 72 - 132M/4	307	142
	25.5	3448	1.6	56.90	30.0	53.0	71.0	80.0			
	32.2	2730	1.6	45.06	29.0	50.0	67.0	80.0			
	12.6	6956	0.8	114.79	19.0	47.0	45.0	60.0	PD 63 - 132M/4 PM 63 - 132M/4	238	139
	15.6	5616	1.1	92.68	26.0	47.0	50.0	60.0			
	19.3	4563	1.3	75.30	26.0	47.0	53.0	60.0			
	19.7	4449	1.3	73.42	26.0	47.0	54.0	60.0			
	24.3	3615	1.5	59.65	26.0	47.0	55.0	60.0			
	28.4	3091	1.6	51.01	26.0	45.0	56.0	60.0			
	34.2	2570	1.8	42.41	25.0	44.0	55.0	60.0			
	40.0	2198	2.1	36.27	25.0	42.0	53.0	60.0			
	46.9	1872	2.4	30.90	24.0	40.0	51.0	60.0			
	50.6	1737	2.6	28.66	24.0	40.0	50.0	60.0			
	59.4	1480	2.9	24.42	23.0	38.0	48.0	60.0			
	23.8	3699	1.2	61.05	27.0	47.0	55.0	60.0	PD 62 - 132M/4 PM 62 - 132M/4	244	138
	29.1	3017	1.3	49.79	26.0	46.0	56.0	60.0			
	36.8	2390	1.3	39.44	25.0	43.0	54.0	60.0			
	48.5	1811	2.5	29.89	24.0	40.0	51.0	60.0			
	55.7	1577	2.9	26.02	24.0	39.0	49.0	60.0			
	63.3	1388	3.3	22.91	23.0	37.0	48.0	60.0			
	28.2	3117	1.0	51.45	15.0	30.0	37.0	40.0	PD 52 - 132M/4 PM 52 - 132M/4	157	134
	34.6	2542	1.3	41.96	15.0	29.0	35.0	40.0			
	35.5	2471	1.0	40.79	15.0	28.0	36.0	40.0			
	40.9	2148	1.3	35.45	15.0	29.0	34.0	40.0			
	43.4	2024	1.1	33.41	15.0	27.0	34.0	40.0			
	47.6	1846	1.6	30.47	15.0	28.0	33.0	40.0			
	58.1	1512	1.9	24.96	15.0	27.0	32.0	40.0			
	71.2	1233	2.5	20.36	14.0	26.0	31.0	40.0			
	76.9	1143	2.3	18.86	14.0	25.0	30.0	40.0			
	82.3	1067	2.6	17.61	14.0	25.0	30.0	40.0			
	94.3	932	2.8	15.38	13.0	24.0	29.0	40.0			
	111.5	788	3.1	13.00	13.0	23.0	27.0	40.0			

P ₁ [kW]	n ₂ [Min ⁻¹]	M ₂ [Nm]	f _B	i _{ges}	F _R [kN]	F _A [kN]	F _{R GR} [kN]	F _{A GR} [kN]	Tip / Type	Kg	Sayfa Page mm			
9.20	37.8	2324	0.9	38.35	7.0	14.0	22.0	30.0	PD 42 - 132M/4 PM 42 - 132M/4	121	130			
	45.3	1942	0.9	32.04	8.0	14.0	22.0	30.0						
	54.3	1619	1.0	26.72	8.0	14.0	21.0	30.0						
	54.9	1600	1.1	26.41	8.0	15.0	22.0	30.0						
	64.8	1356	1.3	22.38	8.0	15.0	21.0	30.0						
	67.6	1300	1.3	21.46	9.0	15.0	21.0	30.0						
	79.8	1102	1.6	18.18	9.0	15.0	20.0	30.0						
	95.4	921	2.0	15.19	8.0	15.0	20.0	30.0						
	114.5	768	2.3	12.67	8.0	14.0	19.0	30.0						
	133.9	656	2.6	10.83	8.0	14.0	18.0	30.0						
	157.1	559	2.9	9.23	8.0	13.0	18.0	29.0						
	174.0	505	2.5	8.33	8.0	13.0	17.0	28.0						
	203.5	432	2.8	7.13	7.0	12.0	16.0	27.0						
	238.8	368	3.0	6.07	7.0	12.0	16.0	26.0						
	266.3	330	3.1	5.44	7.0	12.0	15.0	26.0						
	290.0	303	3.2	5.00	7.0	11.0	15.0	25.0						
	309.1	284	3.3	4.69	7.0	11.0	15.0	25.0						
	87.1	1009	0.8	16.65	4.0	7.0	13.0	18.0				PD 32 - 132M/4 PM 32 - 132M/4	105	126
	102.9	854	1.0	14.09	4.0	7.0	12.0	18.0						
	127.7	688	1.2	11.35	4.0	7.0	12.0	17.0						
148.4	592	1.4	9.77	4.0	7.0	12.0	17.0							
174.9	502	1.3	8.29	4.0	7.0	11.0	16.0							
217.0	405	1.5	6.68	4.0	7.0	11.0	16.0							
256.3	343	1.6	5.66	4.0	7.0	10.0	16.0							
323.6	272	1.7	4.48	4.0	7.0	10.0	15.0							
11.0	1.5	69706	0.9	962.15	-	-	21.0	170.0	PD 113/52 - 160M/4B PM 113/52 - 160M/4B	2245	168			
	2.0	52994	1.1	731.47	-	-	77.0	170.0						
	2.4	43720	1.4	603.47	-	-	105.0	170.0						
	3.0	34764	1.7	479.85	-	-	124.0	170.0						
	4.0	26314	1.9	363.21	-	-	137.0	170.0						
	4.6	22621	2.2	312.23	-	-	141.0	170.0						
	6.5	16284	2.7	224.76	-	-	146.0	170.0	PD/PM 113 - 160M/4B	2171	159			
	2.5	41882	0.8	578.09	-	-	87.0	150.0	PD 103/52 - 160M/4B PM 103/52 - 160M/4B	1407	168			
	3.0	34553	1.0	476.93	-	-	107.0	150.0						
	4.0	26529	1.3	366.18	-	-	120.0	150.0						
	4.1	25893	1.4	357.40	-	-	121.0	150.0	PD 103 - 160M/4B PM 103 - 160M/4B	1333	155			
	4.4	24099	1.5	332.64	-	-	124.0	150.0						
	5.1	20492	1.6	282.85	-	-	128.0	150.0						
	5.5	19072	1.7	263.25	-	-	129.0	150.0						
	8.0	13090	2.7	180.68	-	-	134.0	150.0						
	3.5	29739	0.8	410.49	43.0	91.0	120.0	130.0	PD/PM 93/52 - 160M/4B	843	168			
	4.1	25513	1.0	352.16	62.0	102.0	120.0	130.0	PD 93 - 160M/4B PM 93 - 160M/4B	769	151			
	5.0	21078	1.1	290.94	62.0	102.0	120.0	130.0						
	7.1	14827	1.5	204.66	64.0	102.0	120.0	130.0						
	8.3	12680	2.0	175.03	63.0	102.0	120.0	130.0						
10.0	10476	2.3	144.60	61.0	102.0	120.0	130.0							
10.7	9829	2.6	135.66	61.0	102.0	120.0	130.0							
12.6	8369	3.0	115.51	59.0	102.0	115.0	130.0							
14.4	7295	3.3	100.70	59.0	102.0	113.0	130.0							
17.4	6027	3.3	83.19	56.0	96.0	106.0	130.0							
7.8	13443	0.9	185.56	37.0	73.0	100.0	105.0	PD 83 - 160M/4B PM 83 - 160M/4B				467	147	
9.5	11068	1.2	152.77	38.0	72.0	98.0	105.0							
10.1	10426	1.2	143.91	39.0	73.0	98.0	105.0							
12.2	8584	1.5	118.48	39.0	71.0	95.0	105.0							
14.1	7472	1.6	103.13	39.0	70.0	92.0	105.0							
16.0	6578	1.8	90.79	39.0	68.0	90.0	105.0							
19.2	5485	2.2	75.70	38.0	66.0	87.0	105.0							
22.3	4720	2.4	65.16	38.0	64.0	84.0	105.0							
25.3	4153	2.7	57.32	37.0	62.0	82.0	105.0							
20.1	5228	1.5	72.17	38.0	66.0	-	-		PD 82 - 160M/4B PM 82 - 160M/4B	463	146			
24.4	4304	1.5	59.41	37.0	62.0	-	-							
30.5	3442	3.1	47.51	36.0	59.0	-	-							
37.1	2834	3.3	39.12	35.0	56.0	-	-							

P ₁ [kW]	n ₂ [Min ⁻¹]	M ₂ [Nm]	f _B	i _{ges}	F _R [kN]	F _A [kN]	F _{R GR} [kN]	F _{A GR} [kN]	Tip / Type	Kg	Sayfa Page mm				
11.0	11.8	8920	0.8	123.12	26.0	53.0	72.0	80.0	PD 73 - 160M/4B PM 73 - 160M/4B	342	143				
	13.6	7718	1.0	106.53	28.0	53.0	75.0	80.0							
	15.6	6742	1.1	93.05	28.0	53.0	75.0	80.0							
	18.4	5706	1.3	78.75	28.0	51.0	73.0	80.0							
	21.3	4937	1.5	68.14	28.0	51.0	72.0	80.0							
	24.4	4312	1.6	59.52	28.0	50.0	69.0	80.0							
	27.1	3870	1.8	53.42	28.0	49.0	69.0	80.0							
	31.1	3381	2.1	46.66	28.0	48.0	67.0	80.0							
	39.2	2677	2.5	36.95	27.0	45.0	63.0	80.0							
	47.6	2209	2.8	30.49	26.0	43.0	60.0	80.0							
53.9	1951	2.9	26.92	25.0	41.0	58.0	80.0								
61.8	1700	2.9	23.47	25.0	40.0	57.0	80.0								
	20.8	5057	1.1	69.80	29.0	52.0	72.0	80.0	PD 72 - 160M/4B PM 72 - 160M/4B	335	142				
	25.5	4122	1.3	56.90	28.0	50.0	69.0	80.0							
	31.8	3308	1.8	45.66	28.0	48.0	66.0	80.0							
	39.0	2697	2.4	37.22	27.0	46.0	63.0	80.0							
	41.8	2513	2.3	34.69	27.0	45.0	62.0	80.0							
	15.6	6715	0.9	92.68	21.0	43.0	46.0	60.0	PD 63 - 160M/4B PM 63 - 160M/4B	269	139				
	19.3	5456	1.1	75.30	23.0	44.0	50.0	60.0							
	19.7	5319	1.0	73.42	23.0	43.0	51.0	60.0							
	24.3	4322	1.3	59.65	24.0	43.0	54.0	60.0							
	28.4	3696	1.4	51.01	24.0	42.0	55.0	60.0							
	34.2	3073	1.5	42.41	24.0	41.0	53.0	60.0							
	40.0	2628	1.7	36.27	23.0	40.0	51.0	60.0							
	46.9	2239	2.0	30.90	23.0	38.0	50.0	60.0							
	50.6	2076	2.2	28.66	23.0	38.0	49.0	60.0							
59.4	1769	2.5	24.42	22.0	36.0	47.0	60.0								
	23.8	4423	1.0	61.05	24.0	44.0	54.0	60.0	PD 62 - 160M/4B PM 62 - 160M/4B	272	138				
	29.1	3607	1.1	49.79	24.0	42.0	55.0	60.0							
	36.8	2858	1.1	39.44	23.0	40.0	52.0	60.0							
	48.5	2166	2.1	29.89	23.0	38.0	50.0	60.0							
	55.7	1885	2.4	26.02	23.0	37.0	48.0	60.0							
63.3	1659	2.7	22.91	22.0	36.0	47.0	60.0								
	35.5	2955	0.8	40.79	13.0	25.0	34.0	40.0	PD 52 - 160M/4B PM 52 - 160M/4B	188	134				
	43.4	2420	1.0	33.41	14.0	25.0	33.0	40.0							
	47.6	2208	1.3	30.47	14.0	26.0	33.0	40.0							
	58.1	1808	1.6	24.96	14.0	26.0	31.0	40.0							
	71.2	1475	2.1	20.36	13.0	24.0	30.0	40.0							
	76.9	1367	1.9	18.86	13.0	24.0	30.0	40.0							
	82.3	1276	2.2	17.61	13.0	24.0	29.0	40.0							
	94.3	1115	2.3	15.38	13.0	23.0	28.0	40.0							
	111.5	942	2.6	13.00	12.0	22.0	27.0	40.0							
		54.9	1913	0.9	26.41	7.0	13.0	21.0				30.0	PD 42 - 160M/4B PM 42 - 160M/4B	152	130
		55.2	1902	0.8	26.25	7.0	13.0	21.0				30.0			
64.8		1621	1.0	22.38	7.0	13.0	20.0	30.0							
67.6		1555	1.1	21.46	8.0	13.0	20.0	30.0							
79.8		1317	1.4	18.18	8.0	13.0	20.0	30.0							
95.4		1101	1.6	15.19	8.0	13.0	19.0	30.0							
114.5		918	1.9	12.67	8.0	13.0	18.0	30.0							
133.9		785	2.2	10.83	8.0	13.0	18.0	29.0							
157.1		669	2.4	9.23	7.0	13.0	17.0	28.0							
174.0		604	2.1	8.33	7.0	12.0	17.0	27.0							
203.5		516	2.3	7.13	7.0	12.0	16.0	27.0							
238.8		440	2.5	6.07	7.0	11.0	16.0	26.0							
266.3		394	2.7	5.44	7.0	11.0	15.0	25.0							
290.0		362	2.7	5.00	7.0	11.0	15.0	25.0							
309.1	340	2.8	4.69	7.0	11.0	15.0	24.0								

P ₁ [kW]	n ₂ [Min ⁻¹]	M ₂ [Nm]	f _B	i _{ges}	F _R [kN]	F _A [kN]	F _{R GR} [kN]	F _{A GR} [kN]	Tip / Type	Kg	Sayfa Page mm			
15.0	2.0	72264	0.8	731.47	-	-	5.0	170.0	PD 113/52 - 160L/4A PM 113/52 - 160L/4A	2254	168			
	2.4	59618	1.0	603.47	-	-	31.0	170.0						
	3.0	47406	1.3	479.85	-	-	94.0	170.0						
	4.0	35883	1.4	363.21	-	-	122.0	170.0						
	4.6	30847	1.6	312.23	-	-	131.0	170.0						
	6.5	22205	2.0	224.76	-	-	141.0	169.0	PD/PM 113 - 160L/4A	2180	159			
	3.0	47117	0.7	476.93	-	-	72.0	150.0	PD 103/52 - 160L/4A PM 103/52 - 160L/4A	1416	168			
	4.0	36176	1.0	366.18	-	-	103.0	150.0						
	4.1	35309	1.0	357.40	-	-	105.0	150.0	PD 103 - 160L/4A PM 103 - 160L/4A	1342	155			
	4.4	32863	1.1	332.64	-	-	110.0	150.0						
	5.1	27943	1.2	282.85	-	-	118.0	150.0						
	5.5	26007	1.3	263.25	-	-	121.0	150.0						
	8.0	17850	2.0	180.68	-	-	130.0	150.0						
	8.6	16613	2.0	168.16	-	-	131.0	150.0						
	10.3	13871	2.2	140.41	-	-	133.0	150.0						
	5.0	28743	0.8	290.94	47.0	101.0	120.0	130.0	PD 93 - 160L/4A PM 93 - 160L/4A	778	151			
	7.1	20219	1.1	204.66	54.0	102.0	120.0	130.0						
	8.3	17292	1.5	175.03	55.0	102.0	120.0	130.0						
	10.0	14286	1.7	144.60	54.0	100.0	117.0	130.0						
	10.7	13403	1.9	135.66	55.0	100.0	116.0	130.0						
	12.6	11412	2.2	115.51	54.0	97.0	112.0	130.0						
	14.4	9948	2.4	100.70	54.0	95.0	110.0	130.0						
	17.4	8219	2.4	83.19	52.0	89.0	103.0	130.0						
	20.1	7129	2.5	72.17	51.0	87.0	101.0	130.0						
	22.3	6435	2.1	65.13	50.0	84.0	99.0	130.0						
	9.5	15092	0.9	152.77	27.0	56.0	89.0	105.0				PD 83 - 160L/4A PM 83 - 160L/4A	476	147
	10.1	14218	0.9	143.91	29.0	57.0	90.0	105.0						
	12.2	11705	1.1	118.48	30.0	58.0	88.0	105.0						
	14.1	10189	1.2	103.13	32.0	58.0	86.0	105.0						
	16.0	8970	1.3	90.79	33.0	58.0	85.0	105.0						
	19.2	7479	1.6	75.70	33.0	58.0	83.0	105.0						
	22.3	6437	1.8	65.16	33.0	57.0	81.0	105.0						
	25.3	5663	2.0	57.32	33.0	56.0	79.0	105.0						
	30.3	4722	2.2	47.79	33.0	54.0	76.0	105.0						
	33.3	4299	2.2	43.52	33.0	53.0	75.0	105.0						
	40.5	3539	2.2	35.83	32.0	50.0	71.0	102.0						
	47.0	3046	2.3	30.84	31.0	48.0	69.0	99.0						
	20.1	7129	1.1	72.17	34.0	58.0	-	-	PD 82 - 160L/4A PM 82 - 160L/4A	472	146			
	24.4	5870	1.1	59.41	33.0	56.0	-	-						
	30.5	4694	2.3	47.51	33.0	54.0	-	-						
	37.1	3864	2.4	39.12	32.0	52.0	-	-						
	15.6	9193	0.8	93.05	21.0	42.0	70.0	80.0	PD 73 - 160L/4A PM 73 - 160L/4A	351	143			
18.4	7780	1.0	78.75	22.0	42.0	68.0	80.0							
21.3	6732	1.1	68.14	23.0	42.0	67.0	80.0							
24.4	5880	1.2	59.52	24.0	42.0	66.0	80.0							
27.1	5278	1.3	53.42	24.0	43.0	65.0	80.0							
31.1	4610	1.5	46.66	24.0	42.0	64.0	80.0							
39.2	3651	1.8	36.95	24.0	40.0	60.0	80.0							
47.6	3012	2.1	30.49	24.0	39.0	58.0	80.0							
53.9	2660	2.1	26.92	23.0	38.0	57.0	80.0							
20.8	6896	0.8	69.80	24.0	44.0	68.0	80.0	PD 72 - 160L/4A PM 72 - 160L/4A	344	142				
25.5	5622	1.0	56.90	24.0	43.0	66.0	80.0							
31.8	4511	1.3	45.66	25.0	43.0	64.0	80.0							
39.0	3677	1.8	37.22	24.0	41.0	61.0	80.0							
41.8	3427	1.7	34.69	25.0	41.0	60.0	80.0							
53.9	2657	2.2	26.89	24.0	39.0	57.0	80.0							
19.3	7439	0.8	75.30	5.0	33.0	41.0	60.0	PD 63 - 160L/4A PM 63 - 160L/4A	278	139				
19.7	7253	0.8	73.42	14.0	33.0	43.0	60.0							
24.3	5893	0.9	59.65	18.0	34.0	49.0	60.0							
28.4	5040	1.0	51.01	19.0	35.0	51.0	60.0							
34.2	4190	1.1	42.41	20.0	35.0	50.0	60.0							
40.0	3583	1.3	36.27	20.0	35.0	49.0	60.0							
46.9	3053	1.5	30.90	20.0	34.0	48.0	60.0							
50.6	2832	1.6	28.66	20.0	34.0	47.0	60.0							
59.4	2412	1.8	24.42	20.0	33.0	45.0	60.0							

P ₁ [kW]	n ₂ [Min ⁻¹]	M ₂ [Nm]	f _B	i _{ges}	F _R [kN]	F _A [kN]	F _{R GR} [kN]	F _{A GR} [kN]	Tip / Type	Kg	Sayfa Page mm			
15.0	23.8	6031	0.8	61.05	19.0	36.0	49.0	60.0	PD 62 - 160L/4A PM 62 - 160L/4A	281	138			
	29.1	4919	0.8	49.79	20.0	35.0	52.0	60.0						
	36.8	3897	0.8	39.44	20.0	35.0	49.0	60.0						
	48.5	2953	1.5	29.89	21.0	35.0	48.0	60.0						
	55.7	2570	1.8	26.02	21.0	34.0	46.0	60.0						
	63.3	2263	2.0	22.91	20.0	33.0	45.0	60.0						
	77.6	1846	2.0	18.68	20.0	31.0	43.0	60.0						
	98.0	1462	2.0	14.80	19.0	29.0	41.0	59.0						
	117.5	1219	2.2	12.34	18.0	28.0	39.0	56.0						
	47.6	3010	1.0	30.47	11.0	22.0	30.0	40.0				PD 52 - 160L/4A PM 52 - 160L/4A	197	134
	58.1	2466	1.2	24.96	12.0	22.0	30.0	40.0						
	71.2	2011	1.5	20.36	12.0	21.0	28.0	40.0						
	76.9	1864	1.4	18.86	12.0	21.0	28.0	40.0						
	82.3	1740	1.6	17.61	12.0	21.0	28.0	40.0						
	94.3	1520	1.7	15.38	12.0	21.0	27.0	40.0						
	111.5	1284	1.9	13.00	11.0	20.0	26.0	40.0						
	135.2	1060	2.1	10.73	11.0	19.0	25.0	40.0						
	153.1	936	2.2	9.47	11.0	18.0	24.0	40.0						
	166.8	859	1.9	8.69	11.0	18.0	24.0	40.0						
	202.2	708	2.1	7.17	10.0	17.0	23.0	38.0						
	229.0	626	2.2	6.33	10.0	16.0	22.0	37.0						
	254.3	563	2.3	5.70	10.0	16.0	22.0	36.0						
	271.1	528	2.3	5.35	10.0	15.0	21.0	35.0						
	64.8	2211	0.8	22.38	5.0	8.0	18.0	28.0	PD 42 - 160L/4A PM 42 - 160L/4A	161	130			
	67.6	2120	0.8	21.46	5.0	9.0	18.0	28.0						
	79.8	1796	1.0	18.18	6.0	10.0	18.0	28.0						
	95.4	1501	1.2	15.19	6.0	10.0	18.0	28.0						
	114.5	1251	1.4	12.67	6.0	10.0	17.0	27.0						
	133.9	1070	1.6	10.83	6.0	10.0	17.0	27.0						
	157.1	912	1.8	9.23	7.0	11.0	16.0	26.0						
	174.0	823	1.5	8.33	6.0	10.0	16.0	26.0						
	203.5	704	1.7	7.13	6.0	10.0	15.0	25.0						
	238.8	600	1.8	6.07	6.0	10.0	15.0	24.0						
266.3	538	1.9	5.44	6.0	10.0	15.0	24.0							
290.0	494	2.0	5.00	6.0	10.0	14.0	24.0							
309.1	463	2.0	4.69	6.0	10.0	14.0	23.0							
18.5	2.4	73529	0.8	603.47	-	-	2.0	170.0				PD 113/52 - 180M/4B PM 113/52 - 180M/4B	2290	168
	3.0	58467	1.0	479.85	-	-	39.0	170.0						
	4.0	44256	1.1	363.21	-	-	104.0	170.0						
	4.6	38044	1.3	312.23	-	-	119.0	170.0						
	6.5	27386	2.5	224.76	-	-	135.0	165.0	PD 113 - 180M/4B PM 113 - 180M/4B	2212	159			
	8.4	20952	3.3	171.96	-	-	142.0	155.0						
	9.5	18627	3.5	152.87	-	-	144.0	151.0						
	4.0	44617	0.8	366.18	-	-	80.0	150.0	PD 103/52 - 180M/4B PM 103/52 - 180M/4B	1452	168			
	4.8	36809	1.0	302.10	-	-	101.0	150.0						
	8.0	22015	1.6	180.68	-	-	126.0	150.0	PD 103 - 180M/4B PM 103 - 180M/4B	1374	155			
	8.6	20490	1.6	168.16	-	-	128.0	150.0						
	10.3	17108	2.1	140.41	-	-	130.0	150.0						
	6.2	28426	0.8	233.30	27.0	57.0	98.0	123.0	PD 93/52 - 180M/4B PM 93/52 - 180M/4B	888	168			
	7.2	24430	1.0	200.50	30.0	61.0	98.0	123.0						
	8.3	21326	1.2	175.03	47.0	91.0	117.0	130.0	PD 93 - 180M/4B PM 93 - 180M/4B	810	151			
	10.0	17619	1.4	144.60	48.0	89.0	112.0	130.0						
	10.7	16530	1.5	135.66	49.0	91.0	112.0	130.0						
	12.6	14075	1.8	115.51	50.0	89.0	108.0	130.0						
	14.4	12269	2.1	100.70	50.0	88.0	107.0	130.0						
	17.4	10136	2.4	83.19	48.0	83.0	101.0	130.0						
	20.1	8793	2.7	72.17	48.0	82.0	99.0	129.0						
22.3	7936	3.1	65.13	47.0	80.0	97.0	127.0							
26.1	6758	3.3	55.46	46.0	76.0	93.0	122.0							
30.0	5891	3.5	48.35	45.0	74.0	90.0	118.0							

P ₁ [kW]	n ₂ [Min ⁻¹]	M ₂ [Nm]	f _B	i _{ges}	F _R [kN]	F _A [kN]	F _{R GR} [kN]	F _{A GR} [kN]	Tip / Type	Kg	Sayfa Page mm
18.5	12.2	14436	0.9	118.48	23.0	46.0	82.0	105.0	PD 83 - 180M/4B PM 83 - 180M/4B	508	147
	14.1	12566	1.0	103.13	25.0	49.0	81.0	105.0			
	16.0	11062	1.1	90.79	27.0	50.0	80.0	105.0			
	19.2	9224	1.3	75.70	29.0	51.0	79.0	105.0			
	22.3	7939	1.4	65.16	29.0	51.0	77.0	105.0			
	25.3	6984	1.7	57.32	30.0	51.0	76.0	105.0			
	30.3	5823	2.1	47.79	30.0	49.0	73.0	105.0			
	33.3	5302	2.0	43.52	30.0	49.0	73.0	104.0			
	40.5	4365	2.8	35.83	30.0	47.0	69.0	99.0			
	47.0	3757	3.2	30.84	29.0	46.0	67.0	97.0			
	30.5	5789	1.8	47.51	30.0	50.0	-	-	PD 82 - 180M/4B PM 82 - 180M/4B	504	146
	37.1	4766	2.0	39.12	30.0	48.0	-	-			
	51.1	3454	2.9	28.35	29.0	45.0	66.0	95.0			
	18.4	9596	0.8	78.75	17.0	34.0	64.0	80.0	PD 73 - 180M/4B PM 73 - 180M/4B	383	143
	21.3	8303	0.9	68.14	18.0	35.0	63.0	80.0			
	24.4	7253	1.0	59.52	20.0	36.0	62.0	80.0			
	27.1	6509	1.1	53.42	21.0	37.0	62.0	80.0			
	31.1	5686	1.2	46.66	21.0	37.0	61.0	80.0			
	39.2	4503	1.5	36.95	22.0	36.0	58.0	80.0			
	47.6	3715	1.8	30.49	22.0	36.0	56.0	80.0			
	53.9	3280	2.0	26.92	22.0	35.0	55.0	80.0			
	61.8	2860	2.3	23.47	21.0	34.0	54.0	78.0			
	31.8	5563	1.0	45.66	22.0	38.0	61.0	80.0	PD 72 - 180M/4B PM 72 - 180M/4B	376	142
	39.0	4535	1.4	37.22	22.0	37.0	59.0	80.0			
	41.8	4227	1.4	34.69	22.0	38.0	58.0	80.0			
	53.9	3276	1.8	26.89	22.0	36.0	56.0	80.0			
	63.3	2790	2.1	22.90	22.0	35.0	54.0	78.0			
	72.6	2432	2.4	19.96	22.0	34.0	52.0	76.0			
	28.4	6216	0.8	51.01	15.0	29.0	48.0	60.0	PD 63 - 180M/4B PM 63 - 180M/4B	314	139
	34.2	5168	0.9	42.41	17.0	30.0	47.0	60.0			
	40.0	4419	1.0	36.27	17.0	30.0	47.0	60.0			
	46.9	3765	1.2	30.90	18.0	30.0	46.0	60.0			
	50.6	3492	1.3	28.66	18.0	30.0	45.0	60.0			
	59.4	2975	1.6	24.42	18.0	30.0	44.0	60.0			
	48.5	3642	1.2	29.89	19.0	31.0	46.0	60.0	PD 62 - 180M/4B PM 62 - 180M/4B	313	138
	55.7	3170	1.4	26.02	19.0	31.0	45.0	60.0			
	63.3	2791	1.6	22.91	19.0	30.0	44.0	60.0			
	77.6	2276	1.9	18.68	18.0	29.0	42.0	60.0			
	98.0	1803	2.5	14.80	18.0	27.0	40.0	57.0			
	117.5	1504	2.9	12.34	17.0	26.0	38.0	55.0			
	136.5	1294	3.3	10.62	17.0	25.0	37.0	53.0			
	58.1	3041	1.0	24.96	10.0	19.0	28.0	40.0	PD 52 - 180M/4B PM 52 - 180M/4B	233	134
	71.2	2480	1.2	20.36	10.0	19.0	27.0	40.0			
	76.9	2298	1.1	18.86	10.0	19.0	27.0	40.0			
	82.3	2146	1.3	17.61	10.0	19.0	27.0	40.0			
	94.3	1875	1.4	15.38	10.0	19.0	26.0	40.0			
	111.5	1584	1.7	13.00	10.0	18.0	25.0	40.0			
	135.2	1307	1.9	10.73	10.0	18.0	24.0	40.0			
	153.1	1154	2.0	9.47	10.0	17.0	24.0	40.0			
	166.8	1059	2.2	8.69	10.0	17.0	23.0	39.0			
	202.2	874	2.5	7.17	10.0	16.0	22.0	37.0			
	229.0	771	2.7	6.33	9.0	15.0	22.0	36.0			
	254.3	695	2.6	5.70	9.0	15.0	21.0	35.0			
	271.1	652	2.7	5.35	9.0	15.0	21.0	35.0			
	288.8	612	2.8	5.02	9.0	15.0	20.0	34.0			
	336.0	526	2.9	4.32	9.0	14.0	20.0	33.0			

P ₁ [kW]	n ₂ [Min ⁻¹]	M ₂ [Nm]	f _B	i _{ges}	F _R [kN]	F _A [kN]	F _{R GR} [kN]	F _{A GR} [kN]	Tip / Type	Kg	Sayfa Page mm
22.0	3.0	69289	0.9	479.85	-	-	18.0	170.0	PD 113/52 - 180L/4B PM 113/52 - 180L/4B	2298	168
	4.0	52448	1.0	363.21	-	-	77.0	170.0			
	4.7	45086	1.1	312.23	-	-	100.0	169.0			
	6.5	32456	2.1	224.76	-	-	128.0	160.0	PD 113 - 180L/4B PM 113 - 180L/4B	2220	159
	8.5	24831	2.7	171.96	-	-	138.0	152.0			
	9.5	22074	2.9	152.87	-	-	141.0	149.0			
	11.1	18877	3.0	130.73	-	-	144.0	144.0			
	12.9	16228	3.2	112.38	-	-	146.0	139.0			
	4.8	43622	0.8	302.10	-	-	81.0	150.0	PD/PM 103/52 - 180L/4B	1460	168
	8.1	26090	1.3	180.68	-	-	120.0	150.0	PD 103 - 180L/4B PM 103 - 180L/4B	1382	155
	8.7	24283	1.3	168.16	-	-	123.0	150.0			
	10.4	20275	1.7	140.41	-	-	127.0	150.0			
	13.9	15120	2.3	104.71	-	-	132.0	146.0			
	15.9	13191	2.7	91.35	-	-	134.0	141.0			
	7.3	28952	0.8	200.50	20.0	46.0	91.0	113.0	PD/PM 93/52 - 180L/4B	896	168
	8.3	25274	1.0	175.03	39.0	79.0	111.0	130.0	PD 93 - 180L/4B PM 93 - 180L/4B	818	151
	10.1	20880	1.1	144.60	41.0	79.0	108.0	130.0			
	10.7	19589	1.3	135.66	44.0	82.0	108.0	130.0			
	12.6	16680	1.5	115.51	45.0	81.0	105.0	130.0			
	14.4	14540	1.7	100.70	45.0	81.0	104.0	130.0			
	17.5	12013	2.0	83.19	45.0	78.0	100.0	129.0			
	20.2	10421	2.3	72.17	45.0	76.0	97.0	126.0			
	22.3	9405	2.6	65.13	44.0	75.0	95.0	124.0			
	26.2	8009	2.7	55.46	44.0	73.0	91.0	119.0			
	30.1	6981	2.9	48.35	43.0	70.0	88.0	116.0			
	34.7	6056	3.1	41.94	42.0	67.0	85.0	112.0			
	41.0	5125	3.3	35.49	41.0	65.0	82.0	108.0			
	14.1	14892	0.8	103.13	19.0	39.0	76.0	105.0	PD 83 - 180L/4B PM 83 - 180L/4B	516	147
	16.0	13110	0.9	90.79	21.0	42.0	76.0	105.0			
	19.2	10932	1.1	75.70	24.0	44.0	75.0	105.0			
	22.3	9408	1.2	65.16	25.0	45.0	74.0	105.0			
	25.4	8277	1.5	57.32	26.0	45.0	73.0	105.0			
	30.4	6901	1.8	47.79	27.0	45.0	71.0	102.0			
	33.4	6284	1.7	43.52	28.0	45.0	71.0	101.0			
	40.6	5173	2.3	35.83	28.0	44.0	68.0	97.0			
	47.2	4453	2.7	30.84	27.0	43.0	66.0	95.0			
	30.6	6861	1.5	47.51	28.0	46.0	-	-	PD 82 - 180L/4B PM 82 - 180L/4B	512	146
	37.2	5648	1.7	39.12	28.0	44.0	-	-			
	51.3	4094	2.4	28.35	27.0	43.0	65.0	93.0			
	59.4	3539	2.9	24.51	27.0	41.0	63.0	90.0			
	24.4	8595	0.8	59.52	15.0	29.0	59.0	80.0	PD 73 - 180L/4B PM 73 - 180L/4B	391	143
	27.2	7714	0.9	53.42	17.0	32.0	59.0	80.0			
	31.2	6738	1.1	46.66	18.0	33.0	58.0	80.0			
	39.4	5336	1.2	36.95	19.0	33.0	56.0	80.0			
	47.7	4402	1.5	30.49	20.0	33.0	55.0	80.0			
	54.0	3888	1.7	26.92	20.0	32.0	54.0	78.0			
	62.0	3389	2.0	23.47	20.0	32.0	52.0	76.0			
	31.9	6593	0.9	45.66	19.0	34.0	59.0	80.0	PD 72 - 180L/4B PM 72 - 180L/4B	384	142
39.1	5375	1.2	37.22	19.0	33.0	57.0	80.0				
41.9	5010	1.2	34.69	20.0	34.0	57.0	80.0				
54.1	3883	1.5	26.89	21.0	33.0	54.0	79.0				
63.5	3306	1.8	22.90	21.0	33.0	53.0	77.0				
72.9	2882	2.0	19.96	20.0	32.0	51.0	75.0				
89.4	2349	2.8	16.27	20.0	30.0	49.0	71.0				
40.1	5237	0.9	36.27	15.0	26.0	44.0	60.0	PD 63 - 180L/4B PM 63 - 180L/4B	322	139	
47.1	4462	1.0	30.90	15.0	27.0	44.0	60.0				
50.8	4139	1.1	28.66	16.0	27.0	43.0	60.0				
59.6	3526	1.3	24.42	16.0	27.0	42.0	60.0				

22.0 kW
30.0 kW

P ₁ [kW]	n ₂ [Min ⁻¹]	M ₂ [Nm]	f _B	i _{ges}	F _R [kN]	F _A [kN]	F _{R GR} [kN]	F _{A GR} [kN]	Tip / Type	Kg	Sayfa Page mm
22.0	48.7	4316	1.1	29.89	16.0	28.0	44.0	60.0	PD 62 - 180L/4B PM 62 - 180L/4B	321	138
	55.9	3757	1.2	26.02	17.0	28.0	43.0	60.0			
	63.5	3308	1.4	22.91	17.0	28.0	43.0	60.0			
	77.9	2698	1.6	18.68	17.0	27.0	41.0	58.0			
	98.3	2137	2.1	14.80	17.0	26.0	39.0	56.0			
	117.9	1782	2.5	12.34	16.0	25.0	38.0	54.0			
	137.0	1534	2.8	10.62	16.0	24.0	36.0	52.0			
	155.3	1353	2.0	9.37	15.0	23.0	35.0	50.0			
	186.2	1128	2.4	7.81	15.0	22.0	34.0	48.0			
	58.3	3604	0.8	24.96	8.0	16.0	27.0	40.0			
	71.5	2939	1.1	20.36	8.0	16.0	26.0	40.0			
	77.1	2724	1.0	18.86	9.0	17.0	26.0	40.0			
	82.6	2543	1.1	17.61	9.0	16.0	26.0	40.0			
	94.6	2222	1.2	15.38	9.0	17.0	25.0	40.0			
	111.9	1877	1.4	13.00	9.0	16.0	25.0	40.0			
	135.7	1549	1.6	10.73	9.0	16.0	24.0	39.0			
	153.6	1368	1.7	9.47	9.0	16.0	23.0	39.0			
	167.4	1255	1.9	8.69	9.0	15.0	23.0	38.0			
	202.9	1035	2.1	7.17	9.0	15.0	22.0	36.0			
	229.8	914	2.3	6.33	9.0	15.0	21.0	35.0			
255.2	823	2.2	5.70	9.0	14.0	21.0	35.0				
272.1	772	2.3	5.35	9.0	14.0	20.0	34.0				
289.8	725	2.3	5.02	9.0	14.0	20.0	34.0				
337.2	623	2.5	4.32	9.0	13.0	19.0	33.0				
30.0	7.2	39591	2.3	201.75	-	-	116.0	136.0	PD/PM 123 - 200L/4C	2391	162
	6.5	44106	1.6	224.76	-	-	105.0	150.0	PD 113 - 200L/4C PM 113 - 200L/4C	2286	159
	8.5	33744	2.0	171.96	-	-	126.0	145.0			
	9.6	29998	2.3	152.87	-	-	132.0	142.0			
	11.2	25654	2.7	130.73	-	-	137.0	138.0			
	13.0	22053	3.1	112.38	-	-	141.0	134.0			
	10.4	27553	1.3	140.41	-	-	117.0	147.0	PD 103 - 200L/4C PM 103 - 200L/4C	1448	155
	13.9	20548	1.7	104.71	-	-	127.0	139.0			
	16.0	17927	2.0	91.35	-	-	130.0	136.0			
	20.1	14268	2.6	72.71	-	-	133.0	130.0			
	22.3	12842	2.7	65.44	-	-	134.0	128.0			
	10.8	26621	1.0	135.66	30.0	61.0	99.0	124.0	PD 93 - 200L/4C PM 93 - 200L/4C	884	151
	12.6	22668	1.1	115.51	34.0	64.0	98.0	124.0			
	14.5	19760	1.3	100.70	36.0	65.0	96.0	122.0			
	17.5	16325	1.5	83.19	36.0	65.0	93.0	119.0			
	20.2	14161	1.7	72.17	37.0	65.0	91.0	118.0			
	22.4	12782	1.9	65.13	38.0	65.0	90.0	116.0			
	26.3	10883	2.2	55.46	38.0	64.0	87.0	113.0			
	30.2	9487	2.3	48.35	38.0	63.0	85.0	111.0			
	34.8	8230	2.5	41.94	38.0	61.0	83.0	108.0			
41.1	6965	2.7	35.49	38.0	59.0	80.0	104.0				
42.5	6743	2.4	34.36	31.0	46.0	68.0	89.0	PD/PM 92 - 200L/4C	879	150	
19.3	14856	0.8	75.70	13.0	28.0	66.0	96.0	PD 83 - 200L/4C PM 83 - 200L/4C	582	147	
22.4	12786	0.9	65.16	16.0	31.0	66.0	96.0				
25.5	11248	1.1	57.32	19.0	34.0	66.0	95.0				
30.5	9379	1.3	47.79	21.0	36.0	65.0	94.0				
33.6	8539	1.2	43.52	22.0	37.0	65.0	94.0				
40.8	7030	1.7	35.83	23.0	37.0	64.0	91.0				
47.3	6051	2.0	30.84	23.0	37.0	62.0	90.0				
51.5	5563	1.8	28.35	24.0	37.0	62.0	88.0	PD 82 - 200L/4C PM 82 - 200L/4C	578	146	
59.6	4809	2.2	24.51	24.0	36.0	60.0	86.0				
69.1	4149	2.5	21.14	24.0	36.0	58.0	84.0				
83.9	3416	2.5	17.41	23.0	34.0	56.0	80.0				
31.3	9157	0.8	46.66	11.0	22.0	52.0	76.0	PD 73 - 200L/4C PM 73 - 200L/4C	457	143	
39.5	7251	0.9	36.95	13.0	24.0	52.0	75.0				
47.9	5982	1.1	30.49	15.0	26.0	51.0	74.0				
54.2	5283	1.3	26.92	16.0	26.0	50.0	73.0				
62.2	4605	1.4	23.47	16.0	26.0	49.0	72.0				

P ₁ [kW]	n ₂ [Min ⁻¹]	M ₂ [Nm]	f _B	i _{ges}	F _R [kN]	F _A [kN]	F _{R GR} [kN]	F _{A GR} [kN]	Tip / Type	Kg	Sayfa Page mm			
30.0	54.3	5277	1.1	26.89	17.0	27.0	51.0	74.0	PD 72 - 200L/4C PM 72 - 200L/4C	450	142			
	63.8	4493	1.3	22.90	17.0	28.0	50.0	72.0						
	73.2	3917	1.5	19.96	17.0	27.0	49.0	71.0						
	89.7	3193	2.0	16.27	17.0	27.0	47.0	68.0						
	113.3	2528	2.3	12.89	17.0	25.0	44.0	65.0						
	130.6	2193	2.5	11.18	17.0	25.0	43.0	63.0						
	147.3	1945	2.2	9.91	16.0	24.0	42.0	61.0						
	154.3	1856	2.7	9.46	17.0	24.0	42.0	60.0						
	169.0	1696	2.4	8.64	16.0	23.0	40.0	59.0						
	194.8	1471	2.5	7.50	16.0	22.0	39.0	57.0						
	63.7	4495	1.0	22.91	13.0	22.0	39.0	56.0				PD 62 - 200L/4C PM 62 - 200L/4C	387	138
	78.2	3666	1.2	18.68	14.0	22.0	38.0	55.0						
	98.7	2904	1.5	14.80	14.0	22.0	37.0	53.0						
	118.3	2421	1.8	12.34	14.0	22.0	36.0	51.0						
	137.5	2084	2.1	10.62	14.0	21.0	35.0	50.0						
	155.8	1839	1.5	9.37	14.0	20.0	33.0	48.0						
	186.8	1533	1.7	7.81	14.0	20.0	32.0	46.0						
	217.1	1320	2.3	6.73	13.0	19.0	31.0	45.0						
	243.6	1176	2.0	5.99	13.0	19.0	31.0	44.0						
	252.8	1133	2.1	5.78	13.0	18.0	30.0	44.0						
266.0	1077	2.1	5.49	13.0	18.0	30.0	43.0							
298.2	961	2.2	4.90	13.0	18.0	29.0	42.0							
333.2	860	2.4	4.38	13.0	17.0	28.0	41.0							
37.0	7.2	48828	1.8	201.75	-	-	92.0	126.0	PD 123 - 225S/4A PM 123 - 225S/4A	2446	162			
	9.5	37357	2.4	154.35	-	-	120.0	125.0						
	6.5	54398	1.3	224.76	-	-	68.0	142.0	PD 113 - 225S/4A PM 113 - 225S/4A	2341	159			
	8.5	41617	1.7	171.96	-	-	111.0	138.0						
	9.6	36998	1.9	152.87	-	-	121.0	136.0						
	11.2	31640	2.2	130.73	-	-	129.0	133.0						
	13.0	27199	2.5	112.38	-	-	135.0	129.0						
	15.9	22283	2.8	92.07	-	-	141.0	124.0						
	19.0	18638	2.9	77.01	-	-	144.0	120.0						
	10.4	33982	1.0	140.41	-	-	104.0	140.0	PD 103 - 225S/4A PM 103 - 225S/4A	1503	155			
	13.9	25342	1.4	104.71	-	-	122.0	134.0						
	16.0	22110	1.6	91.35	-	-	126.0	131.0						
	20.1	17598	2.1	72.71	-	-	130.0	126.0						
	22.3	15839	2.2	65.44	-	-	131.0	124.0						
	25.7	13738	2.5	56.76	-	-	133.0	120.0						
	30.4	11605	2.2	47.95	-	-	135.0	115.0						
	10.8	32833	0.8	135.66	18.0	43.0	91.0	112.0	PD 93 - 225S/4A PM 93 - 225S/4A	939	151			
	12.6	27957	0.9	115.51	23.0	49.0	91.0	113.0						
	14.5	24371	1.0	100.70	27.0	52.0	90.0	113.0						
	17.5	20134	1.2	83.19	29.0	53.0	88.0	111.0						
20.2	17466	1.4	72.17	31.0	55.0	87.0	111.0							
22.4	15764	1.5	65.13	32.0	56.0	85.0	109.0							
26.3	13423	1.8	55.46	33.0	56.0	84.0	108.0							
30.2	11701	1.9	48.35	34.0	56.0	82.0	106.0							
34.8	10150	2.0	41.94	34.0	56.0	80.0	104.0							
41.1	8590	2.2	35.49	34.0	54.0	78.0	101.0							
42.5	8317	2.0	34.36	28.0	42.0	66.0	85.0	PD 92 - 225S/4A PM 92 - 225S/4A	934	150				
47.4	7452	2.1	30.79	28.0	41.0	64.0	84.0							
54.4	6498	2.2	26.85	28.0	40.0	63.0	82.0							
63.0	5608	2.3	23.17	27.0	39.0	61.0	80.0							
25.5	13872	0.9	57.32	12.0	24.0	60.0	87.0	PD 83 - 225S/4A PM 83 - 225S/4A	637	147				
30.5	11567	1.0	47.79	15.0	28.0	61.0	88.0							
33.6	10532	1.0	43.52	17.0	30.0	61.0	88.0							
40.8	8671	1.4	35.83	18.0	31.0	60.0	86.0							
47.3	7463	1.6	30.84	20.0	32.0	59.0	85.0							

37.0 kW
45.0 kW

P ₁ [kW]	n ₂ [Min ⁻¹]	M ₂ [Nm]	f _B	i _{ges}	F _R [kN]	F _A [kN]	F _{R GR} [kN]	F _{A GR} [kN]	Tip / Type	Kg	Sayfa Page mm	
37.0	51.5	6861	1.5	28.35	21.0	32.0	59.0	84.0	PD 82 - 225S/4A PM 82 - 225S/4A	633	146	
	59.6	5931	1.8	24.51	21.0	32.0	58.0	83.0				
	69.1	5117	2.0	21.14	21.0	32.0	56.0	81.0				
	83.9	4213	2.0	17.41	21.0	31.0	54.0	78.0				
	96.1	3675	2.1	15.19	21.0	31.0	53.0	76.0				
	112.4	3143	2.3	12.99	21.0	30.0	51.0	74.0				
	134.2	2633	2.4	10.88	21.0	29.0	49.0	71.0				
	151.0	2340	2.1	9.67	20.0	27.0	48.0	68.0				
	176.6	2001	2.3	8.27	19.0	27.0	46.0	66.0				
	47.9	7378	0.9	30.49	11.0	20.0	47.0	69.0	PD 73 - 225S/4A PM 73 - 225S/4A	512	143	
	54.2	6516	1.0	26.92	12.0	21.0	47.0	68.0				
	62.2	5680	1.2	23.47	13.0	22.0	47.0	68.0				
	54.3	6508	0.9	26.89	13.0	22.0	48.0	70.0	PD 72 - 225S/4A PM 72 - 225S/4A	505	142	
	63.8	5541	1.0	22.90	14.0	23.0	47.0	69.0				
	73.2	4830	1.2	19.96	15.0	24.0	47.0	67.0				
	89.7	3938	1.6	16.27	15.0	23.0	45.0	65.0				
	113.3	3118	1.9	12.89	15.0	23.0	43.0	62.0				
	130.6	2705	2.1	11.18	15.0	23.0	42.0	61.0				
	147.3	2399	1.8	9.91	15.0	22.0	40.0	59.0				
	154.3	2289	2.2	9.46	15.0	22.0	40.0	59.0				
	169.0	2091	1.9	8.64	15.0	21.0	39.0	57.0				
	194.8	1814	2.0	7.50	15.0	21.0	38.0	56.0				
	230.2	1535	2.2	6.34	14.0	20.0	37.0	54.0				
	275.4	1283	2.3	5.30	14.0	19.0	35.0	51.0				
	342.4	1032	2.5	4.26	14.0	18.0	33.0	49.0				
	63.7	5544	0.8	22.91	10.0	17.0	37.0	52.0	PD 62 - 225S/4A PM 62 - 225S/4A	442	138	
	78.2	4521	1.0	18.68	11.0	18.0	36.0	51.0				
	98.7	3582	1.2	14.80	12.0	19.0	35.0	50.0				
	118.3	2986	1.5	12.34	13.0	19.0	34.0	49.0				
	137.5	2570	1.7	10.62	13.0	19.0	33.0	48.0				
	155.8	2268	1.2	9.37	12.0	18.0	32.0	46.0				
	186.8	1891	1.4	7.81	12.0	18.0	31.0	45.0				
	217.1	1628	1.8	6.73	12.0	17.0	30.0	44.0				
	243.6	1450	1.6	5.99	12.0	17.0	30.0	43.0				
	252.8	1398	1.7	5.78	12.0	17.0	30.0	42.0				
	266.0	1328	1.7	5.49	12.0	17.0	29.0	42.0				
	298.2	1185	1.8	4.90	12.0	17.0	29.0	41.0				
	333.2	1060	1.9	4.38	12.0	16.0	28.0	40.0				
	45.0	9.5	45434	2.0	154.35	-	-	101.0	116.0	PD 123 - 225M/4C PM 123 - 225M/4C	2491	162
		10.6	40391	2.2	137.22	-	-	116.0	116.0			
8.5		50616	1.4	171.96	-	-	85.0	130.0	PD 113 - 225M/4C PM 113 - 225M/4C	2386	159	
9.6		44998	1.5	152.87	-	-	103.0	129.0				
11.2		38481	1.8	130.73	-	-	116.0	127.0				
13.0		33080	2.1	112.38	-	-	127.0	124.0				
15.9		27101	2.4	92.07	-	-	136.0	120.0				
19.0		22668	2.7	77.01	-	-	141.0	117.0				
23.0		18675	3.2	63.44	-	-	144.0	113.0				
13.9		30822	1.1	104.71	-	-	113.0	128.0	PD 103 - 225M/4C PM 103 - 225M/4C	1548	155	
16.0		26890	1.3	91.35	-	-	120.0	125.0				
20.1		21402	1.7	72.71	-	-	126.0	122.0				
22.3		19264	1.8	65.44	-	-	128.0	120.0				
25.7		16708	2.1	56.76	-	-	131.0	116.0				
30.4		14114	2.5	47.95	-	-	133.0	112.0				
12.6		34002	0.7	115.51	11.0	32.0	83.0	101.0	PD 93 - 225M/4C PM 93 - 225M/4C	984	151	
14.5		29640	0.9	100.70	16.0	38.0	83.0	103.0				
17.5		24487	1.0	83.19	20.0	41.0	82.0	102.0				
20.2		21242	1.1	72.17	23.0	44.0	82.0	103.0				
26.3		16325	1.4	55.46	27.0	48.0	80.0	102.0				
30.2	14231	1.7	48.35	29.0	49.0	79.0	101.0					
34.8	12345	1.9	41.94	30.0	49.0	77.0	99.0					
41.1	10447	2.3	35.49	31.0	49.0	75.0	97.0					

P ₁ [kW]	n ₂ [Min ⁻¹]	M ₂ [Nm]	f _B	i _{ges}	F _R [kN]	F _A [kN]	F _{R GR} [kN]	F _{A GR} [kN]	Tip / Type	Kg	Sayfa Page mm
45.0	42.5	10115	1.6	34.36	25.0	37.0	64.0	82.0	PD 92 - 225M/4C PM 92 - 225M/4C	979	150
	47.4	9064	2.0	30.79	25.0	37.0	62.0	81.0			
	54.4	7903	2.2	26.85	25.0	37.0	61.0	79.0			
	63.0	6821	2.4	23.17	25.0	36.0	59.0	77.0			
	72.7	5914	2.7	20.09	25.0	35.0	57.0	75.0			
	84.2	5104	3.0	17.34	25.0	34.0	55.0	72.0			
	30.5	14068	0.9	47.79	8.0	18.0	55.0	80.0	PD 83 - 225M/4C PM 83 - 225M/4C	682	147
	33.6	12809	0.8	43.52	11.0	22.0	56.0	81.0			
	40.8	10546	1.1	35.83	13.0	24.0	56.0	80.0			
	47.3	9076	1.3	30.84	15.0	26.0	55.0	80.0			
	59.6	7213	1.5	24.51	18.0	28.0	55.0	79.0	PD 82 - 225M/4C PM 82 - 225M/4C	678	146
	69.1	6223	1.7	21.14	19.0	28.0	54.0	78.0			
	83.9	5124	1.9	17.41	19.0	28.0	52.0	75.0			
	96.1	4470	2.1	15.19	19.0	28.0	51.0	73.0			
	112.4	3823	2.7	12.99	19.0	27.0	50.0	71.0			
	134.2	3202	3.2	10.88	19.0	27.0	48.0	69.0			
	151.0	2846	2.3	9.67	18.0	25.0	46.0	67.0			
	176.6	2434	3.0	8.27	18.0	25.0	45.0	65.0			
	54.2	7925	0.8	26.92	8.0	15.0	44.0	63.0	PD 73 - 225M/4C PM 73 - 225M/4C	557	143
	62.2	6908	1.0	23.47	9.0	17.0	43.0	63.0			
	63.8	6739	0.9	22.90	11.0	18.0	44.0	65.0	PD 72 - 225M/4C PM 72 - 225M/4C	550	142
	73.2	5875	1.0	19.96	12.0	20.0	44.0	64.0			
	89.7	4789	1.4	16.27	13.0	20.0	43.0	62.0			
	113.3	3793	1.5	12.89	13.0	20.0	41.0	60.0			
	130.6	3290	1.9	11.18	14.0	20.0	40.0	59.0			
	147.3	2918	1.5	9.91	13.0	19.0	39.0	57.0			
	154.3	2784	2.2	9.46	14.0	20.0	39.0	57.0			
	169.0	2543	1.7	8.64	13.0	19.0	38.0	56.0			
	194.8	2206	2.0	7.50	13.0	19.0	37.0	54.0			
	230.2	1867	2.4	6.34	13.0	18.0	36.0	52.0			
	245.0	1754	2.5	5.96	13.0	18.0	35.0	52.0			
	275.4	1561	2.6	5.30	13.0	18.0	35.0	50.0			
	290.2	1481	2.7	5.03	13.0	18.0	34.0	50.0			
342.4	1255	2.9	4.26	13.0	17.0	33.0	48.0				
118.3	3632	1.2	12.34	10.0	16.0	32.0	46.0	PD 62 - 225M/4C PM 62 - 225M/4C	487	138	
137.5	3126	1.4	10.62	11.0	16.0	32.0	46.0				
186.8	2300	1.2	7.81	11.0	16.0	30.0	43.0				
217.1	1980	1.5	6.73	11.0	16.0	29.0	42.0				
243.6	1764	1.4	5.99	11.0	16.0	29.0	41.0				
252.8	1700	1.4	5.78	11.0	16.0	29.0	41.0				
266.0	1615	1.4	5.49	11.0	15.0	28.0	41.0				
298.2	1441	1.5	4.90	11.0	15.0	28.0	40.0				
333.2	1290	1.6	4.38	11.0	15.0	27.0	39.0				
55.0	9.5	55341	1.6	154.35	-	-	67.0				105.0
	10.7	49198	1.8	137.22	-	-	94.0	106.0			
	12.5	42073	2.1	117.35	-	-	113.0	107.0			
	14.5	36167	2.5	100.88	-	-	124.0	106.0			
	8.5	61653	1.1	171.96	-	-	49.0	121.0	PD 113 - 250M/4C PM 113 - 250M/4C	2539	159
	9.6	54809	1.3	152.87	-	-	69.0	120.0			
	11.2	46871	1.5	130.73	-	-	94.0	120.0			
	13.0	40293	1.7	112.38	-	-	113.0	118.0			
	15.9	33011	2.0	92.07	-	-	128.0	116.0			
	19.0	27610	2.3	77.01	-	-	135.0	113.0			
	23.1	22747	2.6	63.44	-	-	140.0	109.0			
	27.0	19453	2.8	54.26	-	-	143.0	106.0			
	14.0	37542	0.9	104.71	-	-	99.0	119.0	PD 103 - 250M/4C PM 103 - 250M/4C	1701	155
	16.0	32753	1.1	91.35	-	-	109.0	119.0			
	20.1	26069	1.4	72.71	-	-	120.0	116.0			
	22.4	23464	1.5	65.44	-	-	125.0	114.0			
	25.8	20351	1.7	56.76	-	-	128.0	112.0			
	30.6	17191	2.0	47.95	-	-	131.0	109.0			
	35.7	14701	2.4	41.00	-	-	133.0	106.0			
	42.6	12316	2.8	34.35	-	-	134.0	102.0			
	49.2	10682	2.9	29.79	-	-	135.0	99.0			
53.9	9746	2.7	27.18	-	-	135.0	97.0				

P ₁ [kW]	n ₂ [Min ⁻¹]	M ₂ [Nm]	f _B	i _{ges}	F _R [kN]	F _A [kN]	F _{R GR} [kN]	F _{A GR} [kN]	Tip / Type	Kg	Sayfa Page mm			
55.0	17.6	29827	0.8	83.19	9.0	26.0	75.0	91.0	PD 93 - 250M/4C PM 93 - 250M/4C	1137	151			
	20.3	25874	0.9	72.17	14.0	32.0	75.0	93.0						
	26.4	19885	1.2	55.46	21.0	38.0	75.0	94.0						
	30.3	17334	1.4	48.35	23.0	40.0	74.0	94.0						
	34.9	15037	1.6	41.94	25.0	41.0	73.0	93.0						
	41.3	12725	1.9	35.49	26.0	43.0	72.0	92.0						
	42.6	12320	1.3	34.36	20.0	31.0	61.0	77.0				PD 92 - 250M/4C PM 92 - 250M/4C	1132	150
	47.6	11040	1.6	30.79	21.0	32.0	60.0	77.0						
	54.6	9627	1.8	26.85	22.0	32.0	59.0	75.0						
	63.2	8308	2.0	23.17	23.0	32.0	57.0	74.0						
	72.9	7204	2.2	20.09	22.0	31.0	55.0	72.0						
	84.5	6217	2.5	17.34	22.0	31.0	54.0	70.0						
	99.7	5268	2.8	14.69	22.0	30.0	52.0	68.0						
	59.8	8786	1.2	24.51	14.0	22.0	52.0	74.0	PD 82 - 250M/4C PM 82 - 250M/4C	831	146			
	69.3	7580	1.4	21.14	15.0	23.0	51.0	74.0						
	84.2	6241	1.6	17.41	16.0	24.0	50.0	72.0						
	96.5	5445	1.7	15.19	17.0	24.0	49.0	70.0						
	112.8	4656	2.2	12.99	17.0	24.0	48.0	69.0						
	134.7	3901	2.6	10.88	17.0	24.0	47.0	67.0						
	151.5	3467	1.9	9.67	17.0	23.0	45.0	65.0						
	177.2	2965	2.5	8.27	17.0	23.0	44.0	63.0						
	211.5	2483	2.7	6.93	17.0	22.0	42.0	61.0						
	324.3	1620	3.0	4.52	16.0	20.0	38.0	55.0						
	75.0	9.6	74953	1.2	154.35	-	-	32.0	82.0	PD 123 - 280M/4A PM 123 - 280M/4A	2824	162		
		10.7	66633	1.4	137.22	-	-	48.0	86.0					
		12.6	56983	1.6	117.35	-	-	65.0	90.0					
		14.6	48985	1.8	100.88	-	-	94.0	92.0					
		17.8	40132	2.2	82.65	-	-	115.0	93.0					
		21.3	33566	2.7	69.12	-	-	125.0	93.0					
		8.6	83502	0.8	171.96	-	-	26.0	102.0	PD 113 - 280M/4A PM 113 - 280M/4A	2719	159		
9.6		74233	0.9	152.87	-	-	32.0	104.0						
11.3		63482	1.1	130.73	-	-	48.0	105.0						
13.1		54572	1.3	112.38	-	-	65.0	106.0						
16.0		44710	1.5	92.07	-	-	103.0	105.0						
19.2		37395	1.7	77.01	-	-	119.0	104.0						
23.2		30808	1.9	63.44	-	-	130.0	102.0						
27.2		26346	2.0	54.26	-	-	136.0	100.0						
31.6		22648	2.2	46.64	-	-	141.0	97.0						
38.6		18555	2.3	38.21	-	-	144.0	94.0						
16.1		44361	0.8	91.35	-	-	77.0	105.0	PD 103 - 280M/4A PM 103 - 280M/4A	1881	155			
20.3		35308	1.1	72.71	-	-	103.0	105.0						
22.5		33180	1.1	65.44	-	-	113.0	104.0						
26.0		27564	1.3	56.76	-	-	118.0	103.0						
30.8		23284	1.5	47.95	-	-	124.0	102.0						
36.0		19911	1.8	41.00	-	-	128.0	100.0						
42.9		16680	2.0	34.35	-	-	131.0	97.0						
49.5		14467	2.1	29.79	-	-	133.0	95.0						
54.3		13201	2.0	27.18	-	-	134.0	93.1						
62.6		11449	2.1	23.58	-	-	135.0	90.0						
70.2		10196	2.2	21.00	-	-	135.0	88.0						
26.6		26932	0.9	55.46	5.0	18.0	65.0	79.0	PD 93 - 280M/4A PM 93 - 280M/4A	1317	151			
30.5		23477	1.0	48.35	10.0	23.0	66.0	81.0						
35.2		20365	1.2	41.94	13.0	26.0	66.0	82.0						
41.6	17234	1.4	35.49	17.0	30.0	66.0	82.0							
42.9	16687	1.0	34.36	12.0	20.0	55.0	69.0	PD 92 - 280M/4A PM 92 - 280M/4A	1312	150				
47.9	14952	1.2	30.79	13.0	22.0	55.0	69.0							
54.9	13038	1.3	26.85	15.0	23.0	54.0	69.0							
63.7	11252	1.5	23.17	17.0	25.0	53.0	68.0							
73.4	9757	1.6	20.09	17.0	24.0	52.0	66.0							
85.1	8420	1.8	17.34	18.0	25.0	51.0	65.0							
100.4	7135	2.1	14.69	19.0	25.0	50.0	64.0							
122.5	5847	2.2	12.04	19.0	25.0	48.0	62.0							
144.5	4956	2.0	10.21	18.0	24.0	46.0	59.0							
170.5	4200	2.1	8.65	18.0	24.0	44.0	58.0							
208.1	3442	2.2	7.09	18.0	23.0	42.0	56.0							

P ₁ [kW]	n ₂ [Min ⁻¹]	M ₂ [Nm]	f _B	i _{ges}	F _R [kN]	F _A [kN]	F _{R GR} [kN]	F _{A GR} [kN]	Tip / Type	Kg	Sayfa Page mm
75.0	60.2	11900	0.9	24.51	5.0	12.0	45.0	65.0	PD 82 - 280M/4A PM 82 - 280M/4A	1011	146
	69.8	10267	1.0	21.14	8.0	14.0	45.0	65.0			
	84.7	8453	1.1	17.41	10.0	16.0	45.0	65.0			
	97.1	7374	1.3	15.19	11.0	17.0	45.0	64.0			
	113.6	6306	1.6	12.99	13.0	19.0	44.0	64.0			
	135.6	5283	1.9	10.88	14.0	19.0	43.0	62.0			
	152.6	4695	1.4	9.67	13.0	19.0	42.0	60.0			
	178.4	4015	1.8	8.27	14.0	19.0	41.0	59.0			
	212.9	3364	2.0	6.93	14.0	19.0	40.0	58.0			
	326.5	2194	2.2	4.52	14.0	18.0	37.0	53.0			
90.0	10.8	79690	1.1	137.22	-	-	23.0	71.0	PD 123 - 280M/4B PM 123 - 280M/4B	2874	162
	12.6	68148	1.3	117.35	-	-	28.0	77.0			
	14.7	58583	1.5	100.88	-	-	52.0	81.0			
	17.9	47996	1.9	82.65	-	-	94.0	84.0			
	21.4	40144	2.2	69.12	-	-	112.0	85.0			
	9.7	88779	0.8	152.87	-	-	21.0	92.0	PD 113 - 280M/4B PM 113 - 280M/4B	2769	159
	11.3	75921	0.9	130.73	-	-	32.0	94.0			
	13.2	65265	1.1	112.38	-	-	39.0	96.0			
	16.1	53470	1.2	92.07	-	-	72.0	98.0			
	19.2	44722	1.4	77.01	-	-	101.0	98.0			
	23.3	36845	1.6	63.44	-	-	120.0	97.0			
	27.3	31509	1.9	54.26	-	-	129.0	95.0			
	31.7	27086	2.2	46.64	-	-	136.0	94.0			
	38.7	22191	2.7	38.21	-	-	141.0	91.0			
	46.3	18561	2.9	31.96	-	-	144.0	88.0			
	42.5	20241	2.1	34.85	-	-	143.0	90.0	PD 112 - 280M/4B PM 112 - 280M/4B	2692	158
	49.5	17374	2.4	29.92	-	-	145.0	87.0			
	20.4	42226	0.9	72.71	-	-	84.0	97.0	PD 103 - 280M/4B PM 103 - 280M/4B	1931	155
	22.6	38007	0.9	65.44	-	-	100.0	97.0			
	26.1	32965	1.1	56.76	-	-	109.0	97.0			
	30.9	27846	1.3	47.95	-	-	118.0	96.0			
	36.1	23813	1.5	41.00	-	-	124.0	95.0			
	43.1	19948	1.8	34.35	-	-	128.0	93.0			
	49.7	17302	2.0	29.79	-	-	130.0	91.0			
	54.4	15787	2.1	27.18	-	-	132.0	89.0			
	62.8	13693	2.4	23.58	-	-	133.0	87.0			
	70.5	12194	2.5	21.00	-	-	134.0	86.0			
	81.1	10595	2.4	18.24	-	-	135.0	84.0	PD 102 - 280M/4B PM 102 - 280M/4B	1906	154
	97.4	8824	2.6	15.19	-	-	136.0	81.0			
	109.6	7843	2.7	13.50	-	-	136.0	79.0			
	127.3	6752	2.8	11.63	-	-	137.0	76.0			
	142.1	6049	2.9	10.42	-	-	137.0	74.0			
	160.8	5344	2.8	9.20	-	-	137.0	72.0			
	48.1	17882	1.0	30.79	7.0	14.0	51.0	63.0	PD 92 - 280M/4B PM 92 - 280M/4B	1362	150
	55.1	15593	1.1	26.85	10.0	17.0	51.0	63.0			
	63.9	13457	1.2	23.17	13.0	19.0	51.0	64.0			
73.7	11668	1.4	20.09	13.0	20.0	49.0	62.0				
85.4	10070	1.5	17.34	15.0	21.0	49.0	62.0				
100.7	8533	1.7	14.69	16.0	22.0	48.0	61.0				
122.9	6993	2.0	12.04	17.0	22.0	46.0	60.0				
145.0	5928	1.8	10.21	16.0	21.0	44.0	57.0				
171.1	5023	2.2	8.65	17.0	21.0	43.0	56.0				
208.8	4116	2.5	7.09	17.0	21.0	41.0	54.0				
256.0	3357	2.6	5.78	17.0	21.0	40.0	52.0				
276.3	3111	2.7	5.36	17.0	20.0	39.0	51.0				

110 kW
132 kW

P ₁ [kW]	n ₂ [Min ⁻¹]	M ₂ [Nm]	f _B	i _{ges}	F _R [kN]	F _A [kN]	F _{R GR} [kN]	F _{A GR} [kN]	Tip / Type	Kg	Sayfa Page mm
110	10.8	97399	0.9	137.22	-	-	14.0	51.0	PD 123 - 315S/4 PM 123 - 315S/4	3054	162
	12.6	83293	1.1	117.35	-	-	17.0	60.0			
	14.7	71602	1.3	100.88	-	-	27.0	66.0			
	17.9	58662	1.5	82.65	-	-	44.0	72.0			
	21.4	49065	1.8	69.12	-	-	94.0	76.0			
	13.2	79769	0.9	112.38	-	-	23.0	84.0	PD 113 - 315S/4 PM 113 - 315S/4	2949	159
	16.1	65353	1.0	92.07	-	-	38.0	88.0			
	19.2	54661	1.1	77.01	-	-	64.0	89.0			
	23.3	45033	1.3	63.44	-	-	100.0	90.0			
	27.3	38511	1.6	54.26	-	-	117.0	89.0			
	31.7	33106	1.8	46.64	-	-	128.0	88.0			
	38.7	27123	2.2	38.21	-	-	136.0	87.0			
	46.3	22685	2.4	31.96	-	-	141.0	85.0			
	42.5	24739	1.7	34.85	-	-	139.0	86.0	PD 112 - 315S/4 PM 112 - 315S/4	2872	158
	49.5	21235	2.0	29.92	-	-	142.0	84.0			
	58.1	18076	2.3	25.47	-	-	145.0	82.0			
	69.1	15203	2.4	21.42	-	-	147.0	79.0			
	22.6	46452	0.8	65.44	-	-	74.0	87.0	PD 103 - 315S/4 PM 103 - 315S/4	2111	155
	26.1	40290	0.9	56.76	-	-	92.0	88.0			
	30.9	34034	1.0	47.95	-	-	107.0	89.0			
	36.1	29105	1.2	41.00	-	-	116.0	89.0			
	43.1	24381	1.4	34.35	-	-	123.0	88.0			
	49.7	21147	1.7	29.79	-	-	127.0	87.0			
	54.4	19295	1.7	27.18	-	-	129.0	85.0			
	62.8	16736	1.9	23.58	-	-	131.0	84.0			
	70.5	14904	2.0	21.00	-	-	132.0	82.0			
	81.1	12949	2.0	18.24	-	-	134.0	81.0			
	97.4	10785	2.1	15.19	-	-	135.0	78.0			
	109.6	9586	2.2	13.50	-	-	135.0	77.0			
	127.3	8253	2.3	11.63	-	-	136.0	74.0			
	142.1	7394	2.4	10.42	-	-	136.0	73.0			
	160.8	6531	2.3	9.20	-	-	137.0	70.0			
	179.5	5851	2.4	8.24	-	-	137.0	69.0			
	195.1	5383	2.1	7.58	-	-	137.0	67.0			
	48.1	21856	0.8	30.79	-	-	45.0	55.0	PD 92 - 315S/4 PM 92 - 315S/4	1542	150
	55.1	19058	0.9	26.85	3.0	9.0	46.0	57.0			
	63.9	16448	1.0	23.17	6.0	12.0	47.0	58.0			
	73.7	14261	1.1	20.09	8.0	13.0	46.0	57.0			
	85.4	12308	1.3	17.34	10.0	15.0	46.0	57.0			
	100.7	10430	1.4	14.69	12.0	17.0	45.0	57.0			
122.9	8547	1.6	12.04	14.0	18.0	44.0	57.0				
145.0	7245	1.5	10.21	14.0	18.0	43.0	54.0				
171.1	6139	1.8	8.65	14.0	18.0	42.0	53.0				
208.8	5031	2.0	7.09	15.0	19.0	40.0	52.0				
256.0	4104	2.2	5.78	15.0	19.0	39.0	50.0				
276.3	3802	2.2	5.36	15.0	18.0	38.0	50.0				
132	14.7	85922	1.0	100.88	-	-	26.0	50.0			
	17.9	70394	1.3	82.65	-	-	32.0	59.0			
	21.4	58877	1.5	69.12	-	-	52.0	65.0			
	16.1	78423	0.8	92.07	-	-	44.0	76.0	PD 113 - 315M/4 PM 113 - 315M/4	3029	159
	19.2	65593	0.9	77.01	-	-	52.0	80.0			
	23.3	54039	1.1	63.44	-	-	66.0	82.0			
	27.3	46213	1.3	54.26	-	-	97.0	83.0			
	31.7	39727	1.5	46.64	-	-	115.0	83.0			
	38.7	32547	1.8	38.21	-	-	128.0	82.0			
	46.3	27222	2.2	31.96	-	-	136.0	81.0			
	49.5	25483	1.6	29.92	-	-	138.0	80.0	PD 112 - 315M/4 PM 112 - 315M/4	2952	158
	58.1	21692	1.9	25.47	-	-	141.0	79.0			
	69.1	18243	2.3	21.42	-	-	144.0	77.0			

P ₁ [kW]	n ₂ [Min ⁻¹]	M ₂ [Nm]	f _B	i _{ges}	F _R [kN]	F _A [kN]	F _{R GR} [kN]	F _{A GR} [kN]	Tip / Type	Kg	Sayfa Page mm	
132	36.1	34926	1.0	41.00	-	-	105.0	82.0	PD 103 - 315M/4 PM 103 - 315M/4	2191	155	
	43.1	29258	1.2	34.35	-	-	116.0	82.0				
	49.7	25376	1.4	29.79	-	-	122.0	82.0				
	54.4	23154	1.4	27.18	-	-	125.0	81.0				
	62.8	20083	1.6	23.58	-	-	128.0	80.0				
	70.5	17885	1.5	21.00	-	-	130.0	79.0				
	81.1	15539	2.1	18.24	-	-	132.0	78.0	PD 102 - 315M/4 PM 102 - 315M/4	2166	154	
	97.4	12942	2.3	15.19	-	-	134.0	76.0				
	109.6	11503	2.4	13.50	-	-	134.0	75.0				
	127.3	9903	2.5	11.63	-	-	135.0	72.0				
	142.1	8872	2.6	10.42	-	-	136.0	71.0				
	160.8	7837	2.5	9.20	-	-	136.0	69.0				
	179.5	7021	2.6	8.24	-	-	136.0	67.0				
	195.1	6460	2.3	7.58	-	-	137.0	65.0				
	219.6	5742	2.4	6.74	-	-	137.0	64.0				
	255.0	4943	2.5	5.80	-	-	137.0	62.0				
	284.6	4429	2.6	5.20	-	-	133.0	60.0				
	55.1	22870	0.8	26.85	-	-	41.0	49.0				PD 92 - 315M/4 PM 92 - 315M/4
	63.9	19737	0.8	23.17	-	-	42.0	51.0				
	73.7	17114	0.9	20.09	1.0	6.0	42.0	51.0				
	85.4	14769	1.0	17.34	5.0	9.0	42.0	52.0				
	100.7	12516	1.2	14.69	8.0	12.0	42.0	53.0				
	122.9	10256	1.3	12.04	10.0	14.0	42.0	53.0				
	145.0	8694	1.2	10.21	10.0	14.0	40.0	51.0				
	171.1	7367	1.5	8.65	12.0	15.0	40.0	51.0				
	208.8	6037	1.7	7.09	13.0	16.0	39.0	50.0				
	256.0	4924	1.8	5.78	14.0	16.0	38.0	49.0				
	276.3	4563	1.8	5.36	14.0	16.0	37.0	48.0				
	160	18.0	85039	1.1	82.65	-	-	30.0	42.0	PD 123 - 315M/4 PM 123 - 315M/4	3284	
		21.5	71126	1.3	69.12	-	-	77.0	49.0			
19.3		79239	0.8	77.01	-	-	42.0	68.0	PD 113 - 315M/4 PM 113 - 315M/4	3179	159	
23.4		65282	0.9	63.44	-	-	45.0	72.0				
27.4		55827	1.1	54.26	-	-	56.0	74.0				
31.8		47991	1.3	46.64	-	-	94.0	76.0				
38.9		39318	1.5	38.21	-	-	116.0	76.0				
46.5		32886	1.8	31.96	-	-	127.0	76.0				
49.6		30784	1.4	29.92	-	-	131.0	76.0	PD 112 - 315M/4 PM 112 - 315M/4	3102	158	
58.3		26204	1.6	25.47	-	-	136.0	75.0				
69.3		22038	1.9	21.42	-	-	141.0	74.0				
81.3		18798	2.2	18.27	-	-	144.0	72.0				
90.9		16804	2.3	16.33	-	-	145.0	71.0				
105.7		14451	1.8	14.04	-	-	147.0	67.0				
124.2		12302	2.0	11.96	-	-	148.0	66.0				
147.7		10346	2.1	10.05	-	-	149.0	64.0				
173.1		8825	2.2	8.58	-	-	150.0	61.0				
193.7		7889	2.3	7.67	-	-	148.0	60.0				
36.2		42192	0.8	41.00	-	-	85.0	74.0	PD 103 - 315M/4 PM 103 - 315M/4	2341	155	
43.2		35344	1.0	34.35	-	-	104.0	75.0				
49.8		30656	1.1	29.79	-	-	114.0	76.0				
54.6		27971	1.2	27.18	-	-	118.0	75.0				
63.0		24261	1.4	23.58	-	-	123.0	75.0				
70.7		21606	1.3	21.00	-	-	126.0	75.0				
81.4		18771	1.7	18.24	-	-	129.0	74.0	PD 102 - 315M/4 PM 102 - 315M/4	2316	154	
97.7		15634	1.9	15.19	-	-	132.0	73.0				
110.0		13896	2.0	13.50	-	-	133.0	72.0				
127.7		11963	2.1	11.63	-	-	134.0	70.0				
142.6		10718	2.1	10.42	-	-	135.0	69.0				
161.4		9468	2.1	9.20	-	-	136.0	67.0				
180.1	8482	2.1	8.24	-	-	136.0	66.0					
195.8	7804	1.9	7.58	-	-	136.0	64.0					
220.3	6936	2.0	6.74	-	-	136.0	62.0					
255.9	5972	2.1	5.80	-	-	134.0	60.0					
285.6	5350	2.1	5.20	-	-	131.0	59.0					

P ₁ [kW]	n ₂ [Min ⁻¹]	M ₂ [Nm]	f _B	i _{ges}	F _R [kN]	F _A [kN]	F _{R GR} [kN]	F _{A GR} [kN]	Tip / Type	Kg	Sayfa Page mm
160	73.9	20674	0.8	20.09	-	-	36.0	43.0	PD 92 - 315M/4 PM 92 - 315M/4	1772	150
	85.6	17842	0.9	17.34	-	-	38.0	46.0			
	101.1	15119	1.0	14.69	2.0	6.0	39.0	47.0			
	123.3	12389	1.1	12.04	6.0	9.0	39.0	48.0			
	145.5	10502	1.0	10.21	6.0	9.0	38.0	47.0			
	171.7	8900	1.3	8.65	8.0	11.0	37.0	47.0			
	209.5	7293	1.4	7.09	10.0	13.0	37.0	47.0			
	256.9	5949	1.5	5.78	11.0	14.0	36.0	46.0			
	277.2	5512	1.5	5.36	12.0	14.0	36.0	46.0			
	200	21.5	89028	1.0	69.12	-	-	70.0			
31.8		60070	1.0	46.64	-	-	31.0	66.0	PD 113 - 315L/4 PM 113 - 315L/4	3319	159
38.8		49214	1.2	38.21	-	-	90.0	68.0			
46.4		41163	1.5	31.96	-	-	111.0	69.0			
49.6		38532	1.1	29.92	-	-	118.0	69.0	PD 112 - 315L/4 PM 112 - 315L/4	3242	158
58.2		32800	1.3	25.47	-	-	127.0	69.0			
69.2		27585	1.5	21.42	-	-	135.0	69.0			
81.2		23529	1.8	18.27	-	-	140.0	68.0			
90.8		21034	1.9	16.33	-	-	142.0	67.0			
105.6		18089	1.5	14.04	-	-	145.0	64.0			
124.0		15398	1.6	11.96	-	-	146.0	62.0			
147.5		12950	1.7	10.05	-	-	148.0	61.0			
172.9		11046	1.8	8.58	-	-	147.0	59.0			
193.4		9874	1.9	7.67	-	-	144.0	58.0			
81.3		23496	1.4	18.24	-	-	124.0	69.0	PD 102 - 315L/4 PM 102 - 315L/4	2456	154
97.6		19569	1.5	15.19	-	-	128.0	68.0			
109.8		17393	1.6	13.50	-	-	130.0	68.0			
127.6		14974	1.7	11.63	-	-	132.0	67.0			
142.4		13416	1.7	10.42	-	-	133.0	66.0			
161.2		11851	1.7	9.20	-	-	134.0	64.0			
179.9		10617	1.7	8.24	-	-	135.0	63.0			
195.5		9768	1.5	7.58	-	-	135.0	61.0			
220.0		8682	1.6	6.74	-	-	133.0	60.0			
255.5		7475	1.6	5.80	-	-	130.0	58.0			
285.2		6696	1.7	5.20	-	-	127.0	57.0			

Ölçü Tabloları

Dimension Tables

PD/PM - MOTOR



PD/PM - IEC

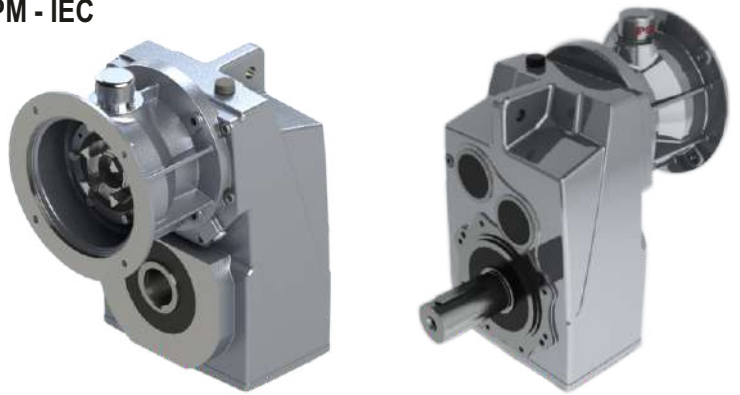

PD/PM - W



PD/PM - PAM

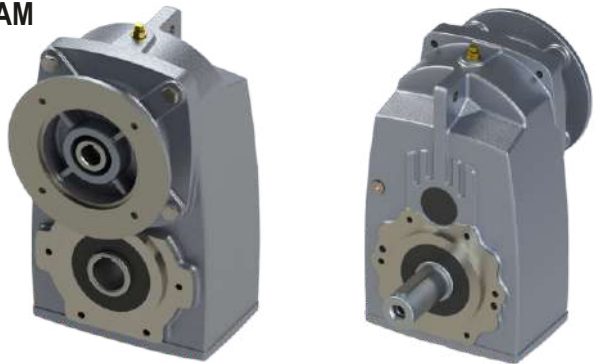

PD / PM

PD/PM A02

PD A02

PD A02 B5

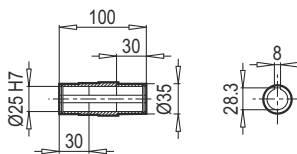
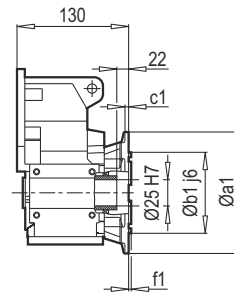
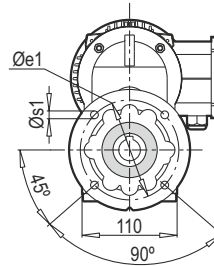
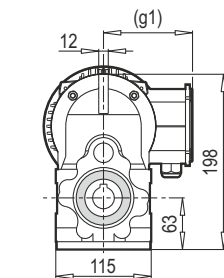
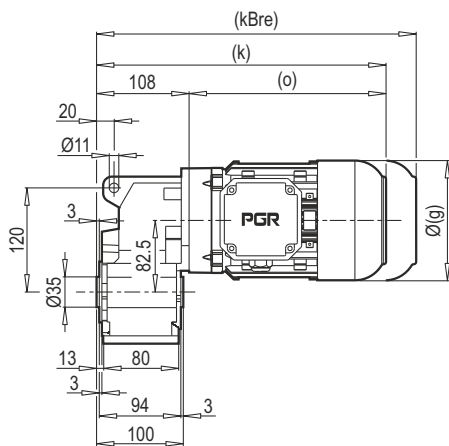

a1	b1	c1	e1	f1	s1
140	95	10	115	3	4x9

PM A02

PM A02 B5

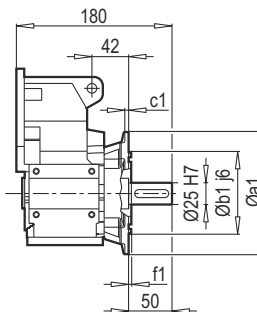
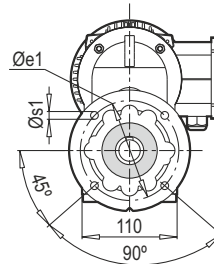
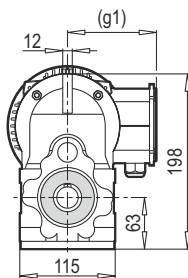
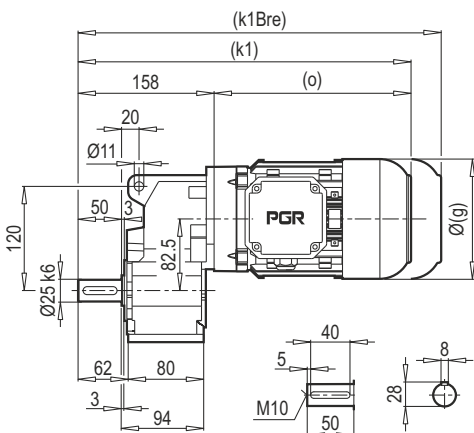

PD A02 Ç

62 - 63

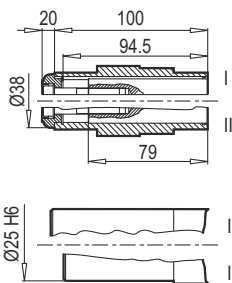

Ayak Delik Ölçüleri sayfa 46 / Dimension of foot is on page 46

	63 M	71 M	80 M				
g	124	140	159				
g1	111	119	127				
k/k1	301/351	332/382	350/400				
kBre/k1Bre	353/403	392/442	412/462				
o	193	224	242				

Not : (...) İşaretli olan ölçüler Motor markasına göre farklılık gösterir / Note : The dimensions which have (...) sign vary depending on the motor brand.

PD A02

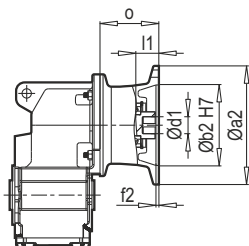

IEC

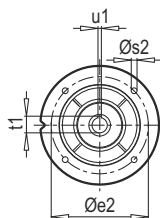

PM A02

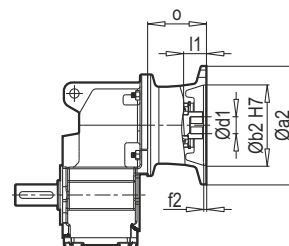

Tip / Type	IEC	Øa2	Øb2	Øe2	f2	Øs2	Ød1	l1	t1	u1	o
PD/PM A02	63	140	95	115	3.5	M8	11	23	12.8	4	85
	71	160	110	130	4.0	M8	14	30	16.3	5	85
	80	200	130	165	4.0	M10	19	40	21.8	6	103
	90	200	130	165	4.0	M10	24	50	27.3	8	103

~ Kg	
IEC	PD/PM A02
63	7
71	8
80	10
90	10

PD A02

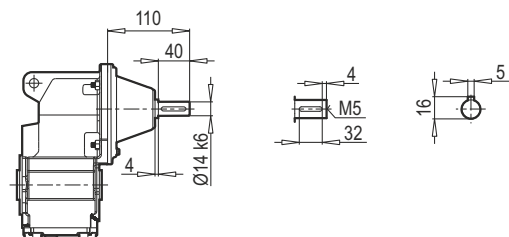

W

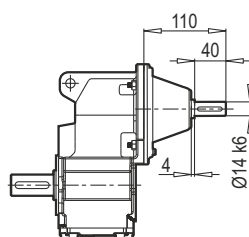

PM A02

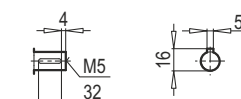

W ~ Kg	
PD/PM A02	
PD/PM A02	6

PD A02

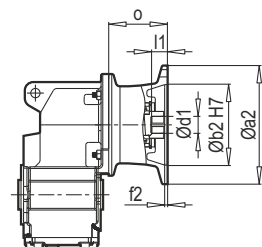

PAM B5/B14

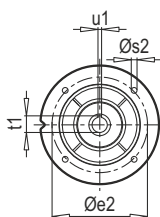

PM A02

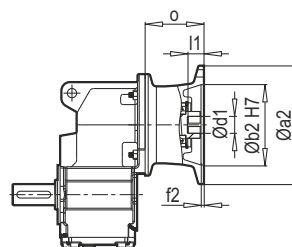

Tip / Type	PAM B5	Øa2	Øb2	Øe2	f2	Øs2	Ød1	l1	t1	u1	o
PD/PM A02	63	140	95	115	3.5	M8	11	23	12.8	4	85
	71	160	110	130	4.0	M8	14	30	16.3	5	85
	80	200	130	165	4.0	M10	19	40	21.8	6	103
	90	200	130	165	4.0	M10	24	50	27.3	8	103

~ Kg	
PAM B5	PD/PM A02
63	7
71	8
80	10
90	10

Tip / Type	PAM B14	Øa2	Øb2	Øe2	f2	Øs2	Ød1	l1	t1	u1	o
PD/PM A02	63	90	60	75	3.5	6	11	23	12.8	4	85
	71	105	70	85	4.0	7	14	30	16.3	5	85
	80	120	80	100	4.0	7	19	40	21.8	6	103
	90	140	95	115	4.0	9	24	50	27.3	8	103

~ Kg	
PAM B14	PD/PM A02
63	6
71	7
80	9
90	9

PD/PM B02

PD B02

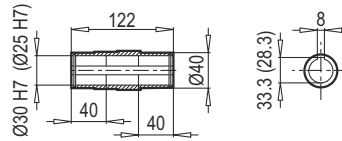
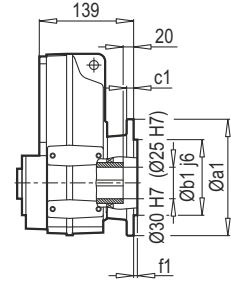
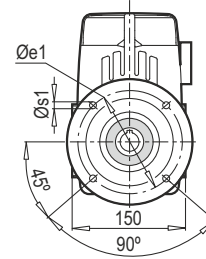
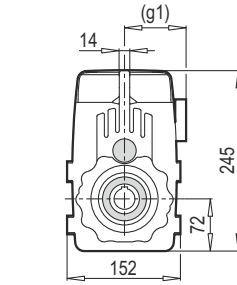
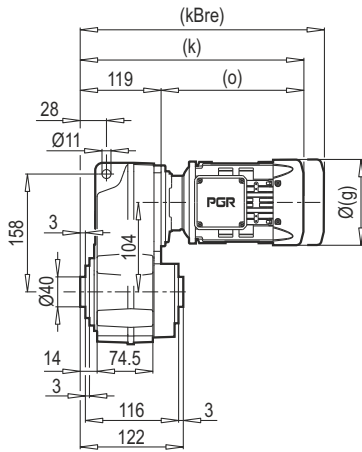

a1	b1	c1	e1	f1	s1
160	110	12	130	3.5	4x9

PM B02

PM B02 B5

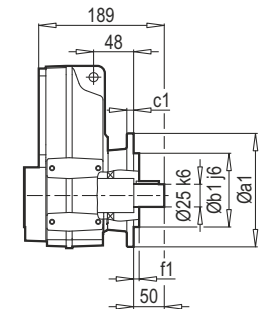
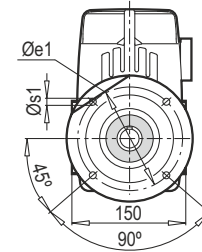
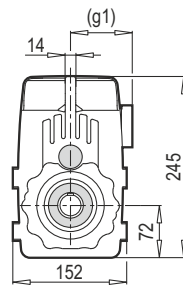
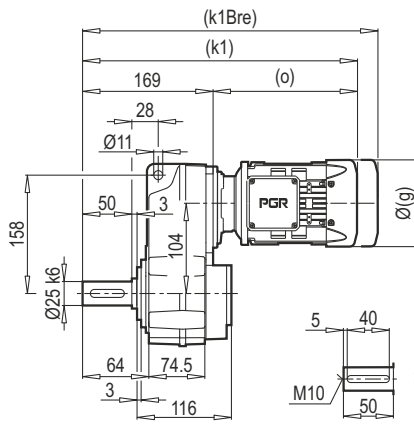

PD B02 KS

PD B02 Ç

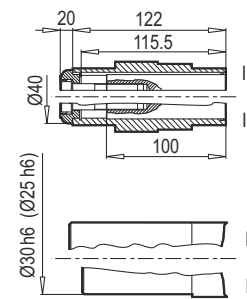
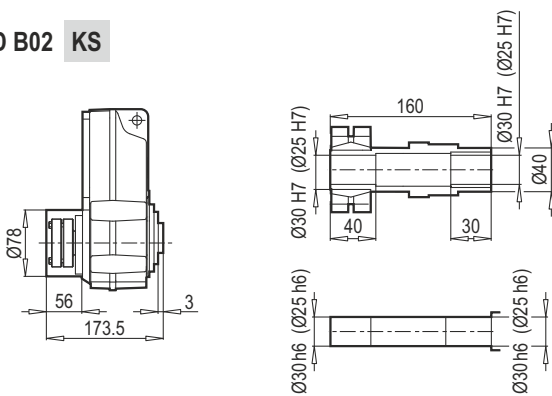

Ayak Delik Ölçüleri sayfa 46 / Dimension of foot is on page 46

62 - 63

	63 M	71 M	80 M	90 S	90 L			
g	124	140	159	193	193			
g1	111	119	127	151	151			
k/k1	312/362	343/393	361/411	386/436	406/456			
kBre/k1Bre	364/414	403/453	423/473	459/509	479/529			
o	193	224	242	267	287			

Not : (...) İşaretili olan ölçüler Motor markasına göre farklılık gösterir / Note : The dimensions which have (...) sign vary depending on the motor brand.

PD B02

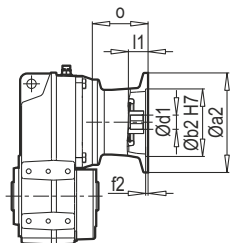

IEC

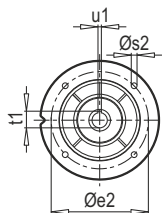

PM B02

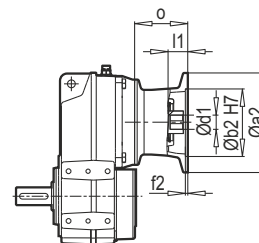

Tip / Type	IEC	Øa2	Øb2	Øe2	f2	Øs2	Ød1	l1	t1	u1	o
PD/PM B02	63	140	95	115	3.5	M8	11	23	12.8	4	85
	71	160	110	130	4.0	M8	14	30	16.3	5	85
	80	200	130	165	4.0	M10	19	40	21.8	6	103
	90	200	130	165	4.0	M10	24	50	27.3	8	103

~ Kg	
IEC	PD/PM B02
63	11
71	12
80	15
90	15

PD B02

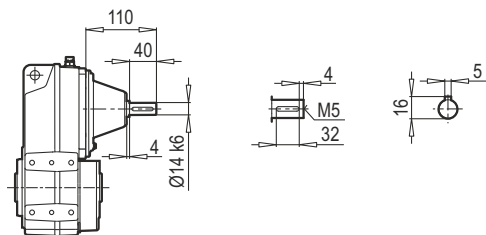

W

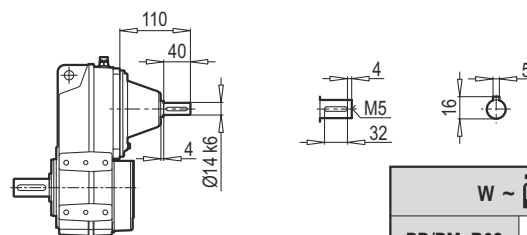

PM B02

W ~ Kg	
PD/PM B02	
PD/PM B02	10

PD B02

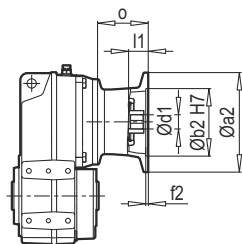

PAM B5/B14

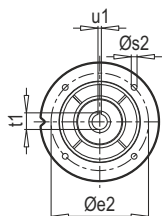

PM B02

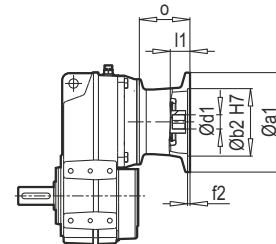

Tip / Type	PAM B5	Øa2	Øb2	Øe2	f2	Øs2	Ød1	l1	t1	u1	o
PD/PM B02	63	140	95	115	3.5	M8	11	23	12.8	4	85
	71	160	110	130	4.0	M8	14	30	16.3	5	85
	80	200	130	165	4.0	M10	19	40	21.8	6	103
	90	200	130	165	4.0	M10	24	50	27.3	8	103

~ Kg	
PAM B5	PD/PM B02
PAM B5	PD/PM B02
63	10
71	11
80	14
90	14

Tip / Type	PAM B14	Øa2	Øb2	Øe2	f2	Øs2	Ød1	l1	t1	u1	o
PD/PM B02	63	90	60	75	3.5	6	11	23	12.8	4	85
	71	105	70	85	4.0	7	14	30	16.3	5	85
	80	120	80	100	4.0	7	19	40	21.8	6	103
	90	140	95	115	4.0	9	24	50	27.3	8	103

~ Kg	
PAM B14	PD/PM B02
PAM B14	PD/PM B02
63	9
71	10
80	13
90	13

PD/PM C13

PD C13

PD C13 B5

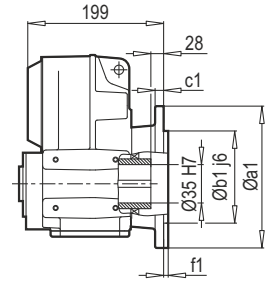
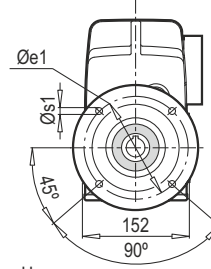
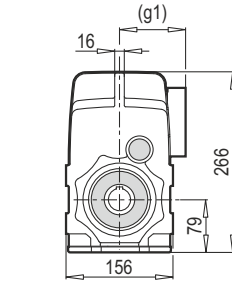
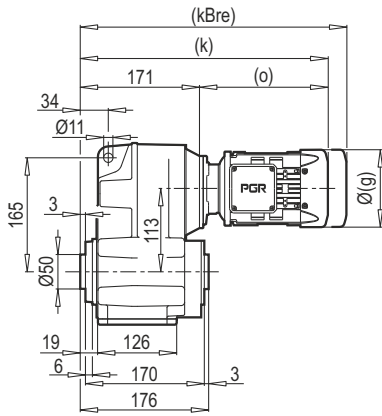

dH	Ø 35	(Ø 30)	(Ø 25)
uH	10	(8)	(8)
tH	38.3	(33.3)	(28.3)

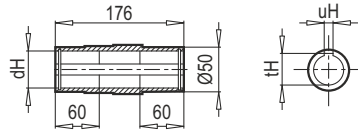

a1	b1	c1	e1	f1	s1
160	110	12	130	3.5	4x9
200	130	12	165	3.5	4x11

PM C13

PM C13 B5

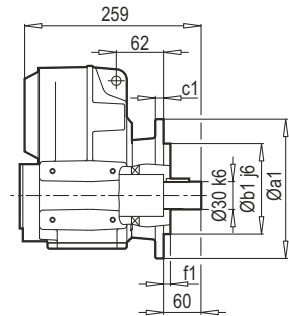
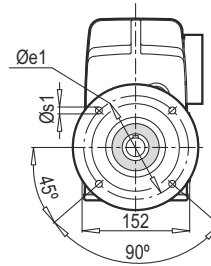
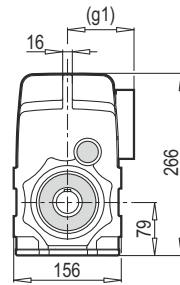
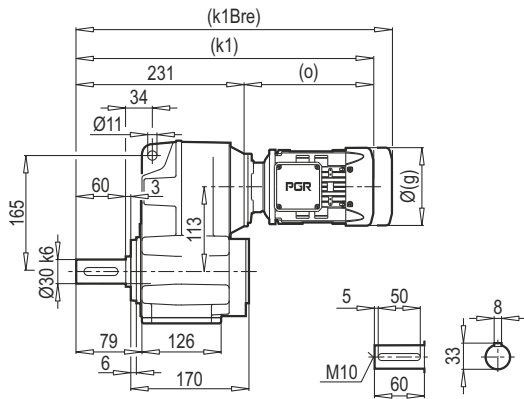

PD C13 KS

PD C13 Ç

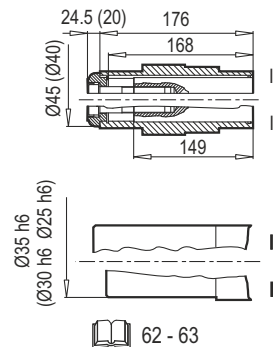
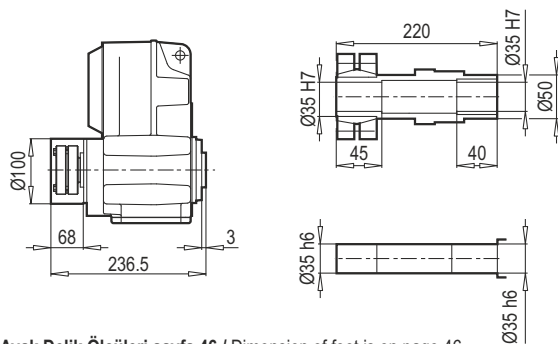

Ayak Delik Ölçüleri sayfa 46 / Dimension of foot is on page 46

	63 M	71 M	80 M	90 S	90 L	100 L	
g	124	140	159	193	193	217	
g1	111	119	127	151	151	160	
k/k1	364/424	395/455	413/473	438/498	458/518	487/547	
kBre/k1Bre	416/476	455/515	475/535	511/571	531/591	568/628	
o	193	224	242	267	287	316	

Not : (...) İşaretili olan ölçüler Motor markasına göre farklılık gösterir / Note : The dimensions which have (...) sign vary depending on the motor brand.

PD C13

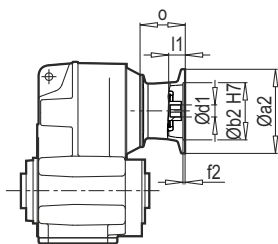

IEC

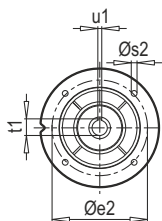

PM C13

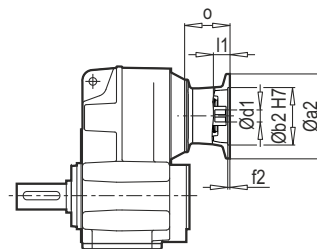

Tip / Type	IEC	Øa2	Øb2	Øe2	f2	Øs2	Ød1	l1	t1	u1	o
PD/PM C13	63	140	95	115	3.5	M8	11	23	12.8	4	85
	71	160	110	130	4.0	M8	14	30	16.3	5	85
	80	200	130	165	4.0	M10	19	40	21.8	6	103
	90	200	130	165	4.0	M10	24	50	27.3	8	103
	100	250	180	215	5.0	M12	28	60	31.3	8	126

~ Kg	
IEC	PD/PM C13
63	24
71	25
80	27
90	27
100	32

PD C13

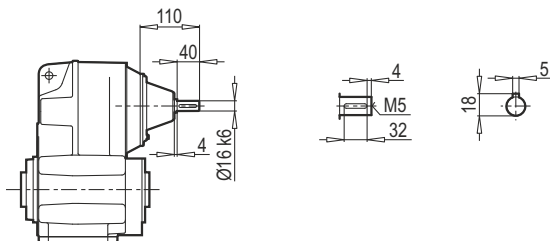

W

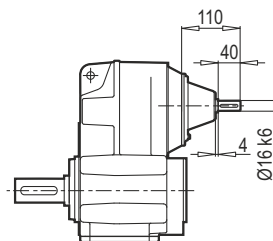

PM C13

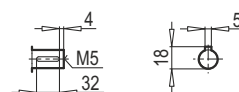

W ~ Kg	
PD/PM C13	
	23

PD C13

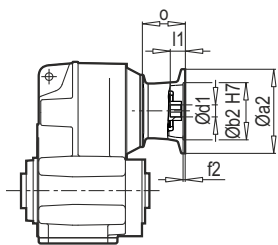

PAM B5/B14

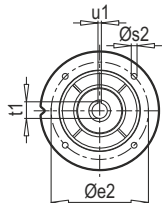

PM C13

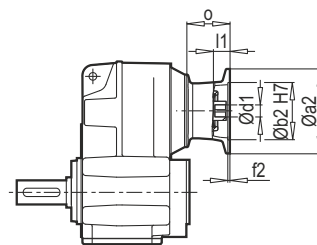

Tip / Type	PAM B5	Øa2	Øb2	Øe2	f2	Øs2	Ød1	l1	t1	u1	o
PD/PM C13	63	140	95	115	3.5	M8	11	23	12.8	4	85
	71	160	110	130	4.0	M8	14	30	16.3	5	85
	80	200	130	165	4.0	M10	19	40	21.8	6	103
	90	200	130	165	4.0	M10	24	50	27.3	8	103
	100	250	180	215	5.0	M12	28	60	31.3	8	126

~ Kg	
PAM B5	PD/PM C13
63	23
71	24
80	26
90	26
100	31

Tip / Type	PAM B14	Øa2	Øb2	Øe2	f2	Øs2	Ød1	l1	t1	u1	o
PD/PM C13	63	90	60	75	3.5	6	11	23	12.8	4	85
	71	105	70	85	4	7	14	30	16.3	5	85
	80	120	80	100	4	7	19	40	21.8	6	103
	90	140	95	115	4	9	24	50	27.3	8	103
	100	160	110	130	5	9	28	60	31.3	8	126

~ Kg	
PAM B14	PD/PM C13
63	22
71	23
80	25
90	25
100	30

PD/PM 12

PD 12

PD 12 B5

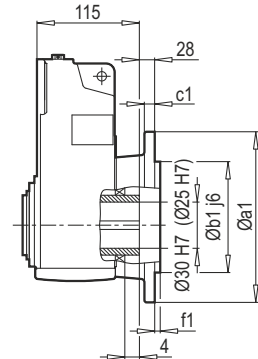
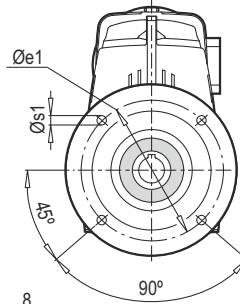
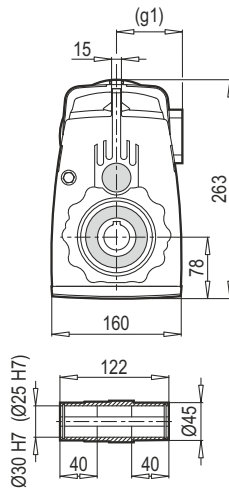
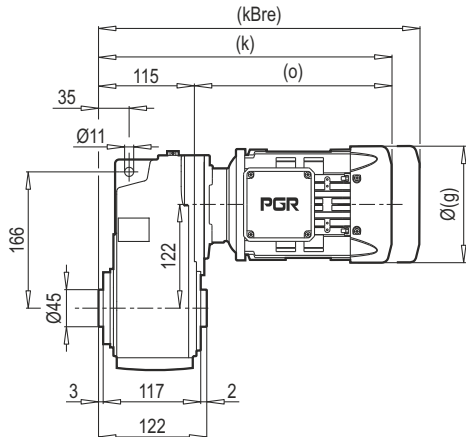

a1	b1	c1	e1	f1	s1
200	130	12	165	3.5	4x11

PM 12

PM 12 B5

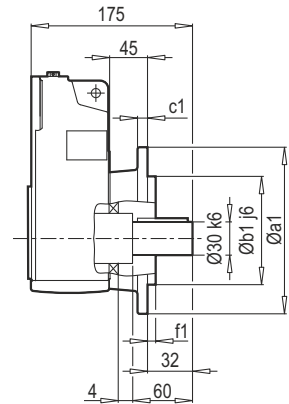
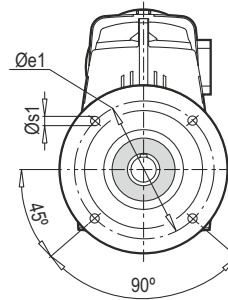
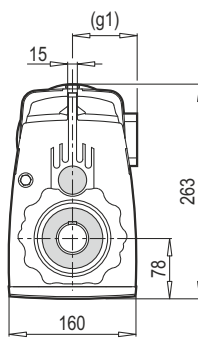
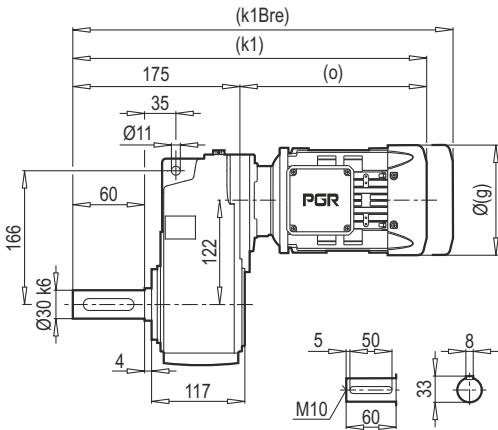

PD 12 KS

PD 12 DIN 5480

PD 12 Ç

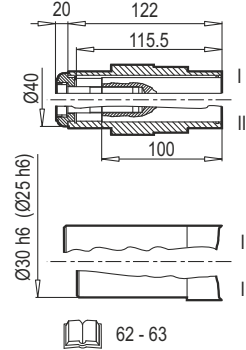
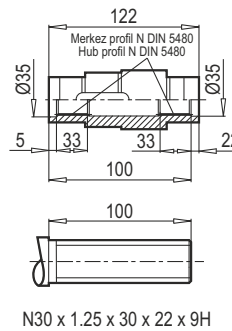
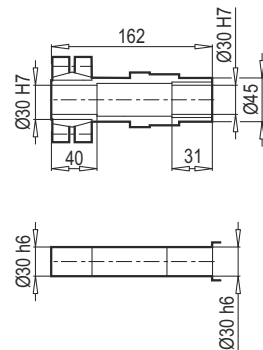
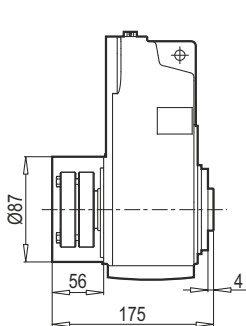

	63 M	71 M	80 M	90 S	90 L	100 L	112 M
g	124	140	159	193	193	217	232
g1	111	119	127	151	151	160	168
k/k1	313/373	355/415	382/442	405/465	425/485	453/513	498/558
kBre/k1Bre	365/425	415/475	444/504	478/538	498/558	534/594	578/638
o	198	240	267	290	310	338	383

Not : (...) İşaretli olan ölçüler Motor markasına göre farklılık gösterir / Note : The dimensions which have (...) sign vary depending on the motor brand.

PD 13

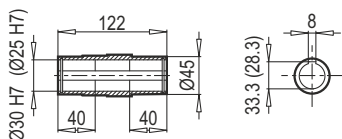
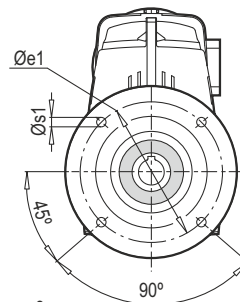
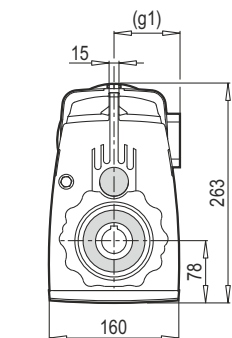
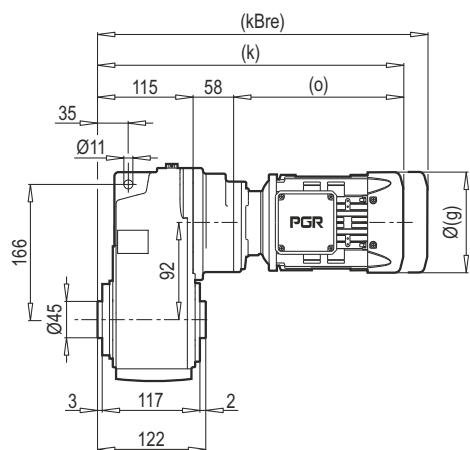

PD 13 B5

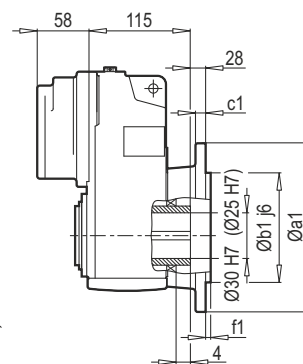

a1	b1	c1	e1	f1	s1
200	130	12	165	3.5	4x11

PM 13

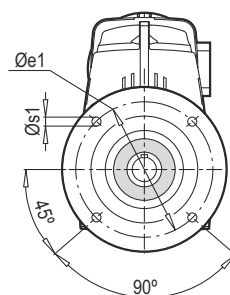
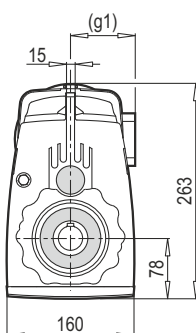
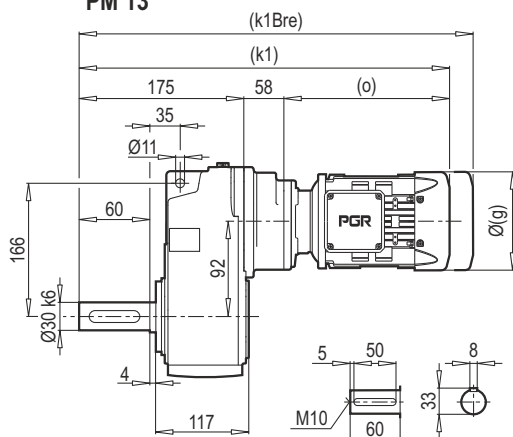

PM 13 B5

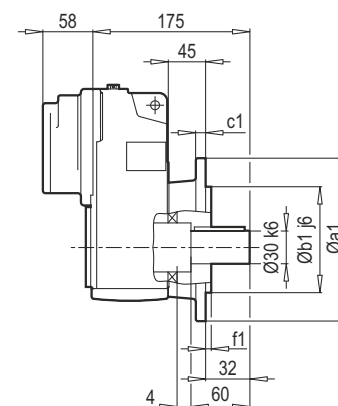

PD 13 KS

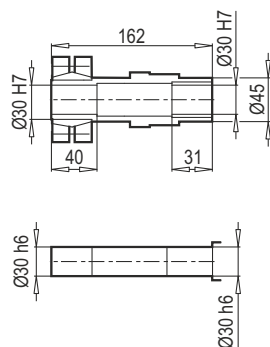
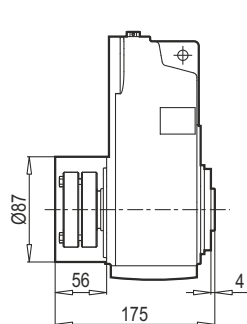

PD 13 DIN 5480

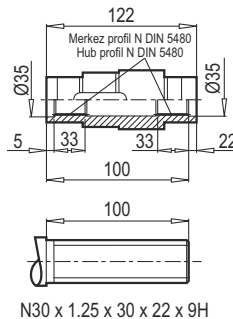

PD 13 Ç

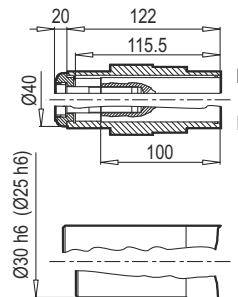

62 - 63

	63 M	71 M					
g	124	140					
g1	111	119					
k/k1	371/431	413/473					
kBre/k1Bre	423/483	473/533					
o	198	240					

Not : (...) İşaretli olan ölçüler Motor markasına göre farklılık gösterir / Note : The dimensions which have (...) sign vary depending on the motor brand.

PD/PM 12
PD/PM 13

PD 12
PD 13

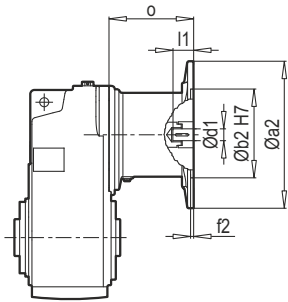

IEC

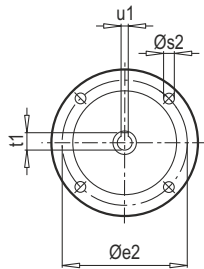

PM 12
PM 13

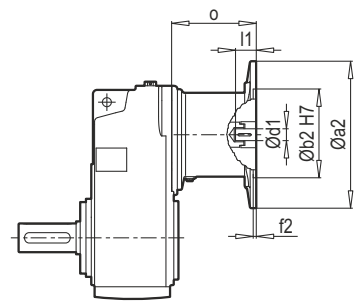

Tip / Type	IEC	Øa2	Øb2	Øe2	f2	Øs2	Ød1	l1	t1	u1	o
PD/PM 12-13	63	140	95	115	3.5	M8	11	23	12.8	4	85
PD/PM 12-13	71	160	110	130	4.0	M8	14	30	16.3	5	89
PD/PM 12	80	200	130	165	4.0	M10	19	40	21.8	6	105
PD/PM 12	90	200	130	165	4.0	M10	24	50	27.3	8	105
PD/PM 12	100	250	180	215	5.0	M12	28	60	31.3	8	130
PD/PM 12	112	250	180	215	5.0	M12	28	60	31.3	8	130

~ Kg		
IEC	PD/PM 12	PD/PM 13
63	20	24
71	21	25
80	24	-
90	24	-
100	31	-
112	31	-

PD 12
PD 13

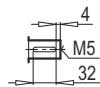
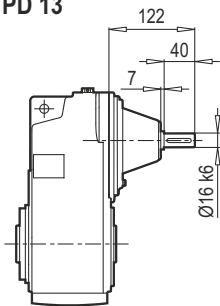

W

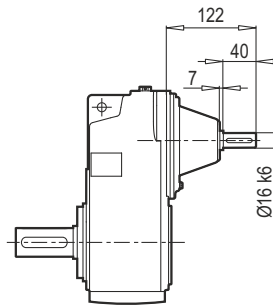

PM 12
PM 13

~ Kg	
PD/PM 12	19
PD/PM 13	23

PD 12
PD 13

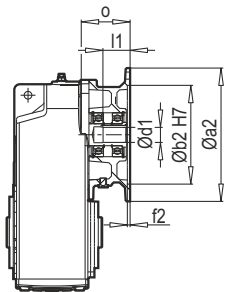

PAM B5/B14

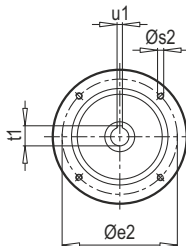

PM 12
PM 13

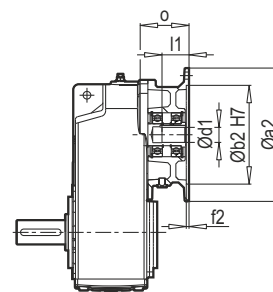

Tip / Type	PAM B5	Øa2	Øb2	Øe2	f2	Øs2	Ød1	l1	t1	u1	o
PD/PM 12-13	63	140	95	115	3.5	M8	11	23	12.8	4	85
PD/PM 12-13	71	160	110	130	4.0	M8	14	30	16.3	5	55
PD/PM 12	80	200	130	165	4.0	M10	19	40	21.8	6	74
PD/PM 12	90	200	130	165	4.0	M10	24	50	27.3	8	74
PD/PM 12	100	250	180	215	5.0	M12	28	60	31.3	8	131.5
PD/PM 12	112	250	180	215	5.0	M12	28	60	31.3	8	131.5

~ Kg		
PAM B5	PD/PM 12	PD/PM 13
63	18	22
71	18	22
80	19	-
90	19	-
100	26	-
112	26	-

Tip / Type	PAM B14	Øa2	Øb2	Øe2	f2	Øs2	Ød1	l1	t1	u1	o
PD/PM 12-13	63	90	60	75	3.5	6	11	23	12.8	4	60
PD/PM 12-13	71	105	70	85	4.0	7	14	30	16.3	5	55
PD/PM 12	80	120	80	100	4.0	7	19	40	21.8	6	74
PD/PM 12	90	140	95	115	4.0	9	24	50	27.3	8	74
PD/PM 12	100	160	110	130	5.0	9	28	60	31.3	8	75
PD/PM 12	112	160	110	130	5.0	9	28	60	31.3	8	75

~ Kg		
PAM B14	PD/PM 12	PD/PM 13
63	17	21
71	17	21
80	18	-
90	18	-
100	19	-
112	19	-

PD 22

PD 22 B5

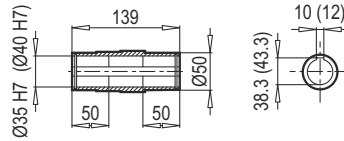
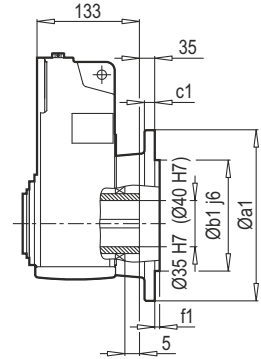
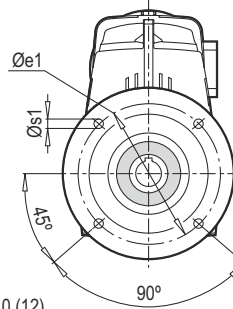
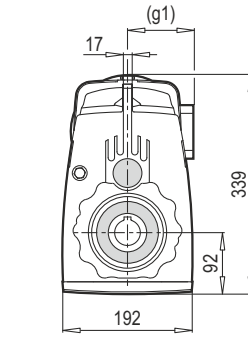
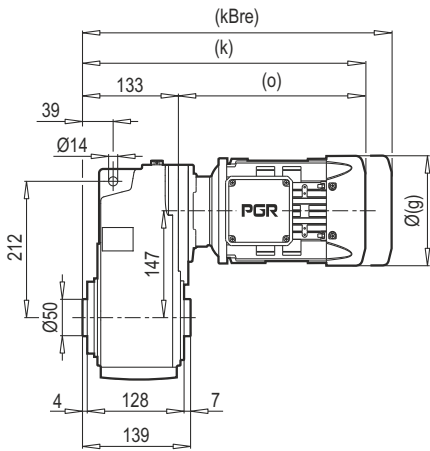

a1	b1	c1	e1	f1	s1
250	180	16	215	4	4x14

PM 22

PM 22 B5

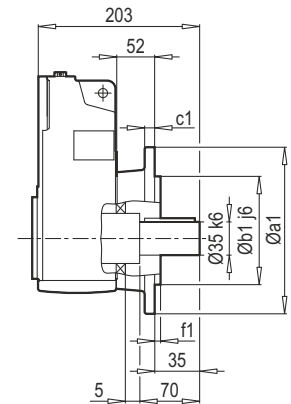
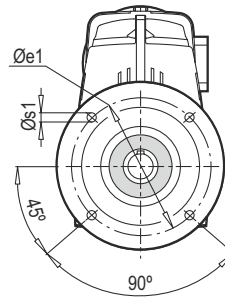
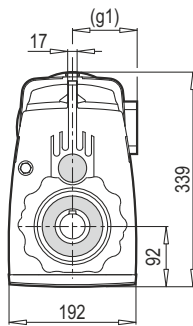
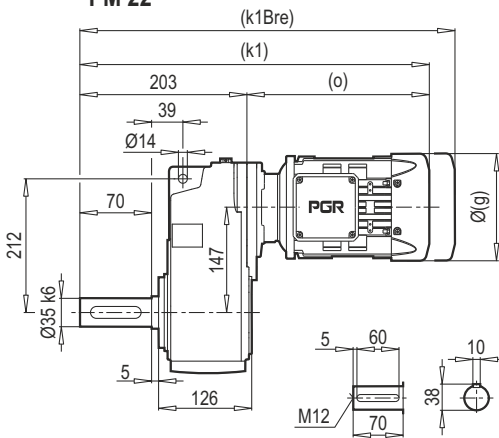

PD 22 KS

PD 22 DIN 5480

PD 22 Ç

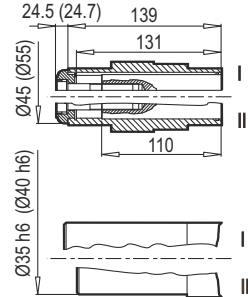
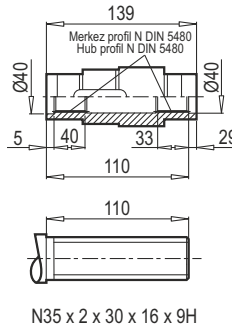
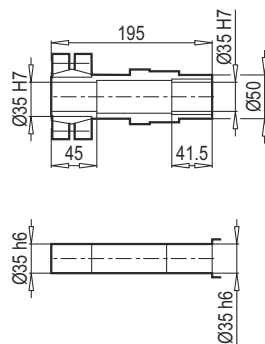
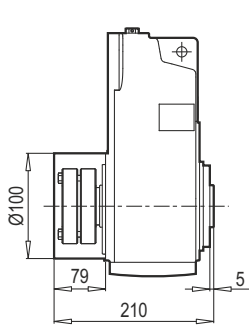

62 - 63

	71 M	80 M	90 S	90 L	100 L	112 M		
g	140	159	193	193	217	232		
g1	119	127	151	151	160	168		
k/k1	369/439	395/465	418/488	438/508	466/536	511/581		
kBre/k1Bre	429/499	457/527	491/561	511/581	547/617	591/661		
o	236	262	285	305	333	378		

Not : (...) İşaretli olan ölçüler Motor markasına göre farklılık gösterir / Note : The dimensions which have (...) sign vary depending on the motor brand.

PD 23

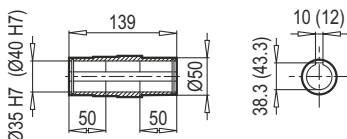
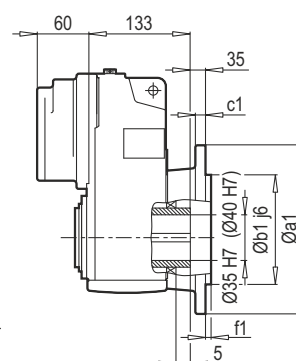
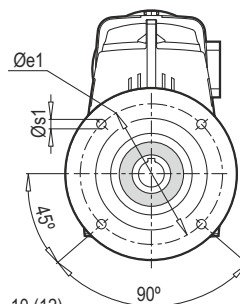
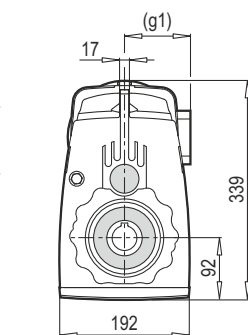
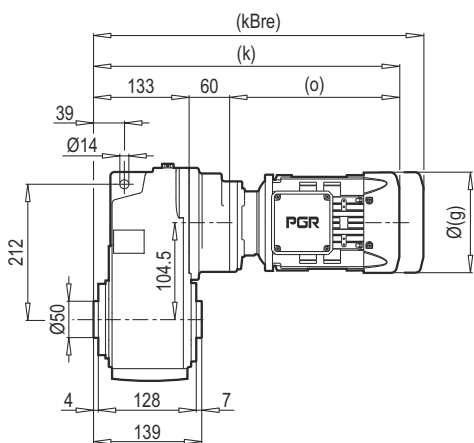

PD 23 B5

a1	b1	c1	e1	f1	s1
250	180	16	215	4	4x14

PM 23

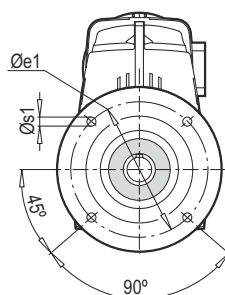
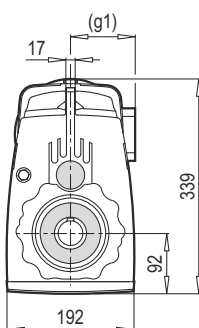
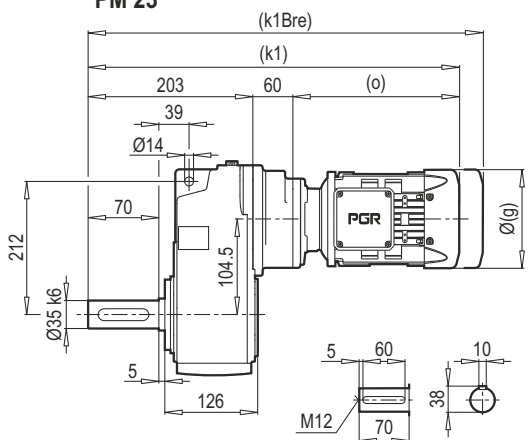

PM 23 B5

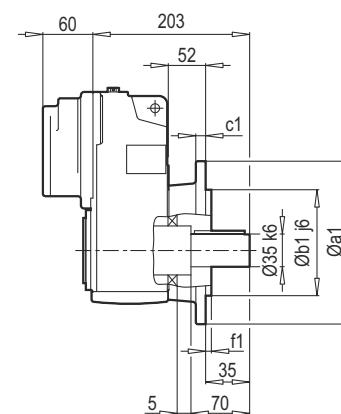

PD 23 DIN 5480

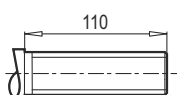
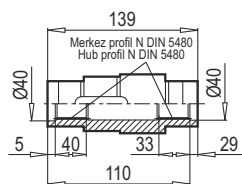

N35 x 2 x 30 x 16 x 9H

PD 23 Ç

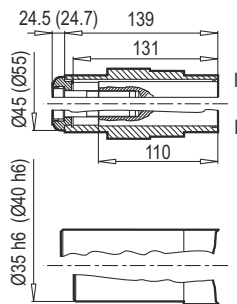

62 - 63

	63 M	71 M	80 M	90 S			
g	124	140	159	193			
g1	111	119	127	151			
k/k1	391/461	433/503	460/530	483/553			
kBre/k1Bre	443/513	493/563	522/592	556/626			
o	198	240	267	290			

Not : (...) İşaretli olan ölçüler Motor markasına göre farklılık gösterir / Note : The dimensions which have (...) sign vary depending on the motor brand.

PD/PM 22
PD/PM 23

PD 22
PD 23

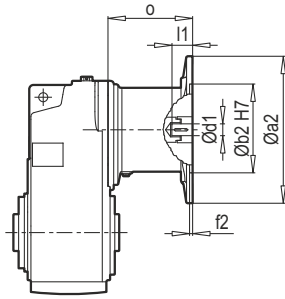

IEC

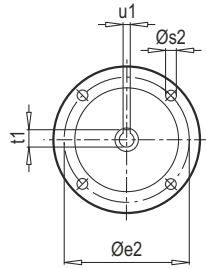

PM 22
PM 23

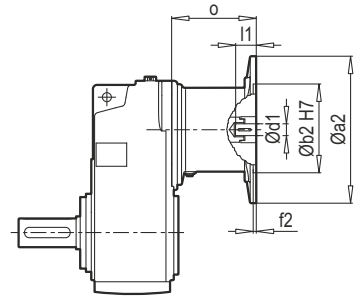

Tip / Type	IEC	Øa2	Øb2	Øe2	f2	Øs2	Ød1	l1	t1	u1	PD/PM 22 o	PD/PM 23 o
PD/PM 23	63	140	95	115	3.5	M8	11	23	12.8	4	85	85
PD/PM 22-23	71	160	110	130	4.0	M8	14	30	16.3	5	88	89
PD/PM 22-23	80	200	130	165	4.0	M10	19	40	21.8	6	105	105
PD/PM 22-23	90	200	130	165	4.0	M10	24	50	27.3	8	105	105
PD/PM 22	100	250	180	215	5.0	M12	28	60	31.3	8	130	-
PD/PM 22	112	250	180	215	5.0	M12	28	60	31.3	8	130	-

~ Kg		
IEC	PD/PM 22	PD/PM 23
63	-	38
71	34	40
80	38	43
90	38	43
100	43	-
112	43	-

PD 22
PD 23

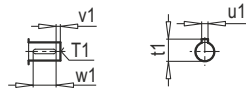
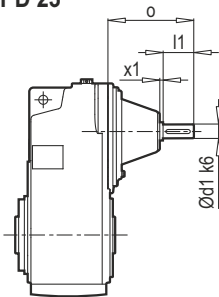

W

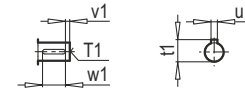
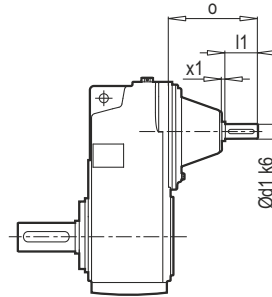

PM 22
PM 23

Tip / Type	Ød1	x1	l1	o	T1	t1	u1	v1	w1
PD/PM 22	24	8	50	172	M8	27	8	5	40
PD/PM 23	16	7	40	122	M5	18	5	4	32

~ Kg	
PD/PM 22	PD/PM 23
36	37

PD 22
PD 23

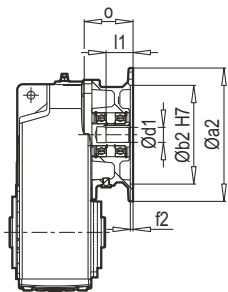

PAM B5/B14

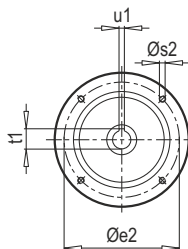

PM 22
PM 23

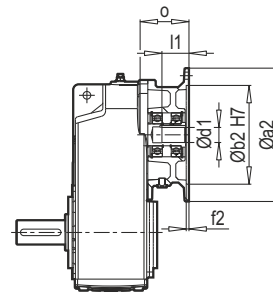

Tip / Type	PAM B5	Øa2	Øb2	Øe2	f2	Øs2	Ød1	l1	t1	u1	o
PD/PM 23	63	140	95	115	3.5	M8	11	23	12.8	4	85
PD/PM 22-23	71	160	110	130	4.0	M8	14	30	16.3	5	55
PD/PM 22-23	80	200	130	165	4.0	M10	19	40	21.8	6	74
PD/PM 22-23	90	200	130	165	4.0	M10	24	50	27.3	8	74
PD/PM 22	100	250	180	215	5.0	M12	28	60	31.3	8	75
PD/PM 22	112	250	180	215	5.0	M12	28	60	31.3	8	75

~ Kg		
PAM B5	PD/PM 22	PD/PM 23
63	-	36
71	32	36
80	33	37
90	33	37
100	34	-
112	34	-

Tip / Type	PAM B14	Øa2	Øb2	Øe2	f2	Øs2	Ød1	l1	t1	u1	o
PD/PM 23	63	90	60	75	3.5	6	11	23	12.8	4	60
PD/PM 22-23	71	105	70	85	4.0	7	14	30	16.3	5	55
PD/PM 22-23	80	120	80	100	4.0	7	19	40	21.8	6	74
PD/PM 22-23	90	140	95	115	4.0	9	24	50	27.3	8	74
PD/PM 22	100	160	110	130	5.0	9	28	60	31.3	8	75
PD/PM 22	112	160	110	130	5.0	9	28	60	31.3	8	75

~ Kg		
PAM B14	PD/PM 22	PD/PM 23
63	-	35
71	30	35
80	31	36
90	31	36
100	33	-
112	33	-

PD 32

PD 32 B5

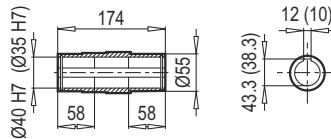
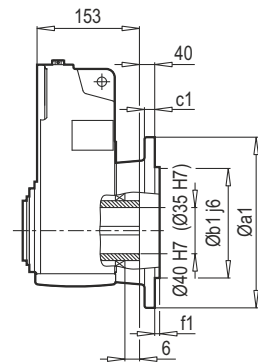
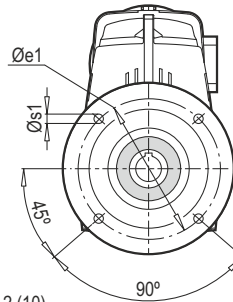
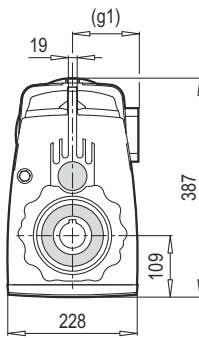
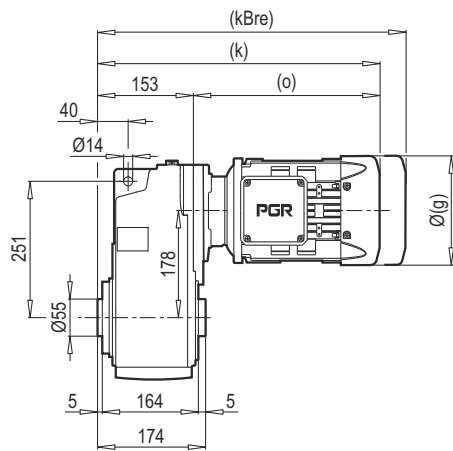

a1	b1	c1	e1	f1	s1
250	180	15	215	4	4x14
300	230	20	265	4	4x14

PM 32

PM 32 B5

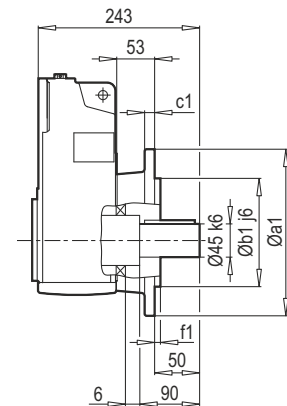
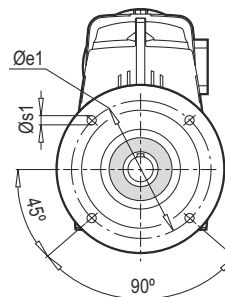
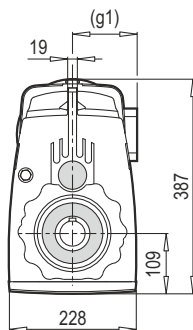
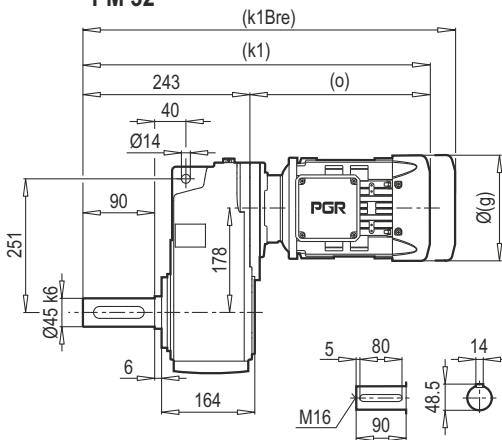

PD 32 KS

PD 32 DIN 5480

PD 32 Ç

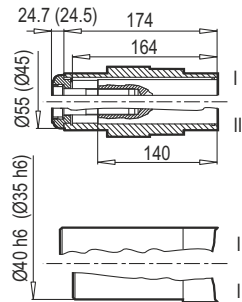
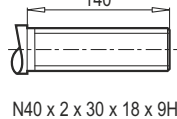
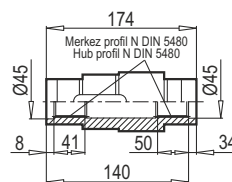
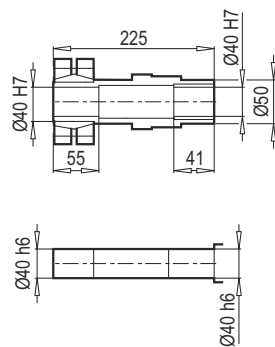
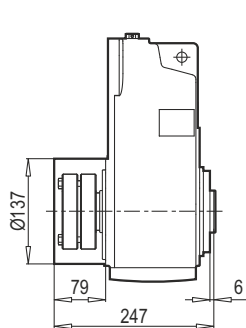

62 - 63

	71 M	80 M	90 S	90 L	100 L	112 M	132 S	132 M
g	140	159	193	193	217	232	279	279
g1	119	127	151	151	160	168	182	182
k/k1	389/479	415/505	438/528	458/548	486/576	531/621	538/628	573/663
kBre/k1Bre	449/539	477/567	511/601	531/621	567/657	611/701	646/736	714/804
o	236	262	285	305	333	378	385	420

Not : (...) İşaretli olan ölçüler Motor markasına göre farklılık gösterir / Note : The dimensions which have (...) sign vary depending on the motor brand.

PD 33

PD 33 B5

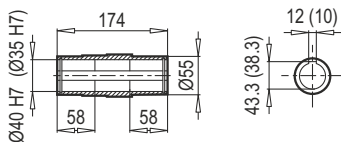
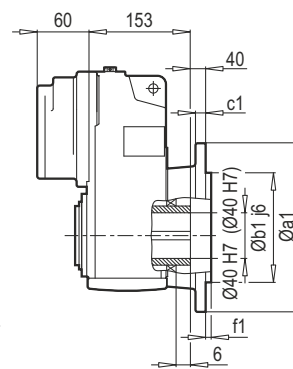
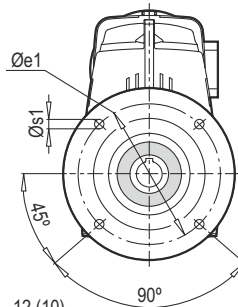
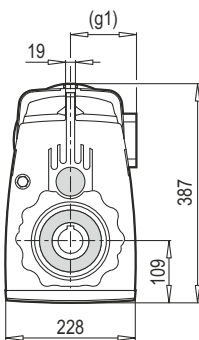
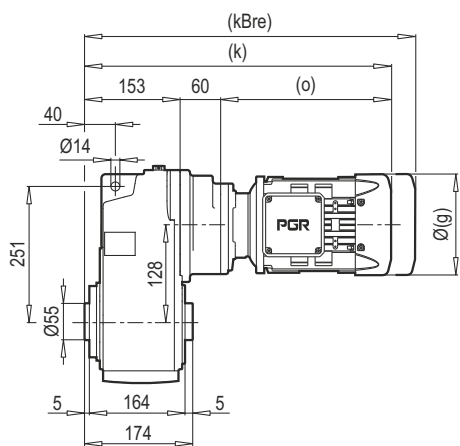

a1	b1	c1	e1	f1	s1
250	180	15	215	4	4x14
300	230	20	265	4	4x14

PM 33

PM 33 B5

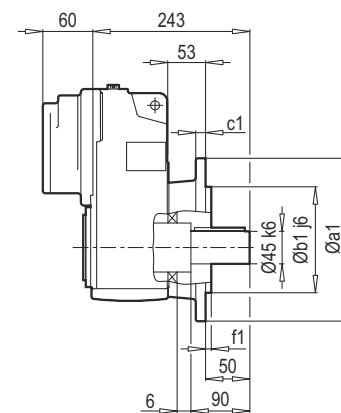
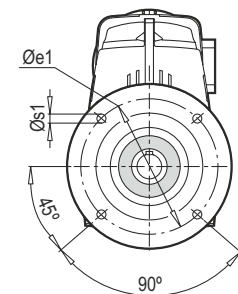
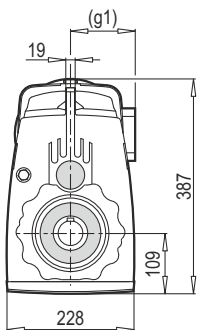
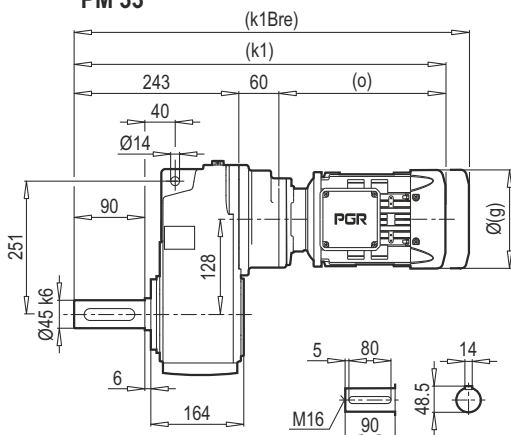

PD 33 KS

PD 33 DIN 5480

PD 33 Ç

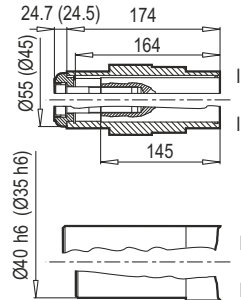
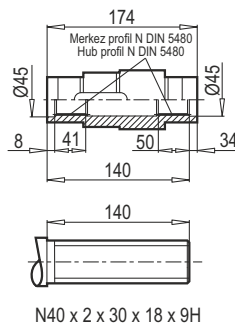
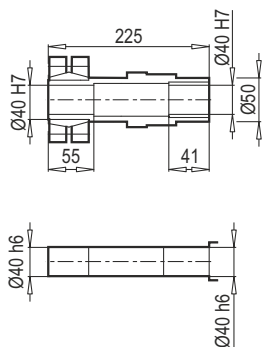
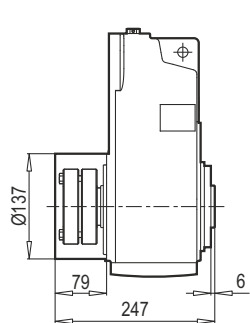

62 - 63

	63 M	71 M	80 M				
g	124	140	159				
g1	111	119	127				
k/k1	411/501	453/543	480/570				
kBre/k1Bre	463/553	513/603	542/632				
o	198	240	267				

Not : (...) İşaretli olan ölçüler Motor markasına göre farklılık gösterir / Note : The dimensions which have (...) sign vary depending on the motor brand.

PD/PM 32
PD/PM 33

PD 32
PD 33

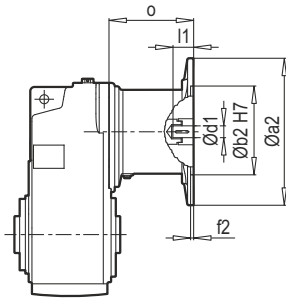

IEC

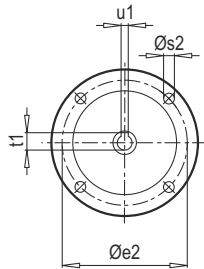

PM 32
PM 33

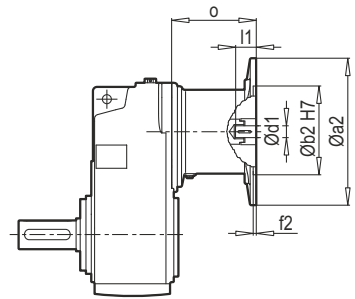

Tip / Type	IEC	Øa2	Øb2	Øe2	f2	Øs2	Ød1	l1	t1	u1	PD/PM 32 o	PD/PM 33 o
PD/PM 33	63	140	95	115	3.5	M8	11	23	12.8	4	-	85
PD/PM 32-33	71	160	110	130	4.0	M8	14	30	16.3	5	88	89
PD/PM 32-33	80	200	130	165	4.0	M10	19	40	21.8	6	107	105
PD/PM 32-33	90	200	130	165	4.0	M10	24	50	27.3	8	107	105
PD/PM 32-33	100	250	180	215	5.0	M12	28	60	31.3	8	124	130
PD/PM 32-33	112	250	180	215	5.0	M12	28	60	31.3	8	124	130
PD/PM 32	132	300	230	265	5.0	M12	38	80	41.3	10	156	-

~ Kg		
IEC	PD/PM 32	PD/PM 33
63	-	55
71	50	56
80	54	59
90	54	59
100	58	67
112	58	67
132	68	-

PD 32
PD 33

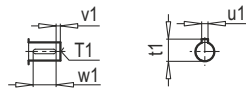
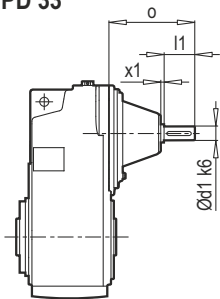

W

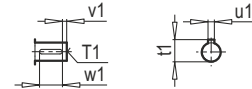
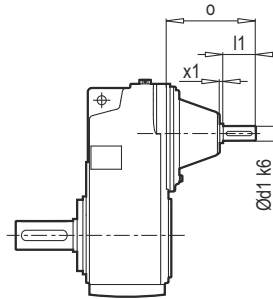

PM 32
PM 33

Tip / Type	Ød1	x1	l1	o	T1	t1	u1	v1	w1
PD/PM 32	24	8	50	172	M8	27	8	5	40
PD/PM 33	16	7	40	122	M5	18	5	4	32

~ Kg	
PD/PM 32	PD/PM 33
52	54

PD 32
PD 33

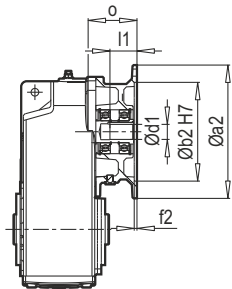

PAM B5/B14

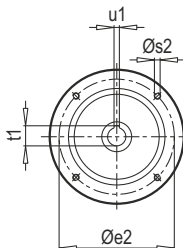

PM 32
PM 33

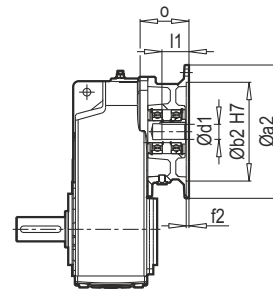

Tip / Type	PAM B5	Øa2	Øb2	Øe2	f2	Øs2	Ød1	l1	t1	u1	o (32)	o (33)
PD/PM 33	63	140	95	115	3.5	M8	11	23	12.8	4	-	85
PD/PM 32-33	71	160	110	130	4.0	M8	14	30	16.3	5	88	55
PD/PM 32-33	80	200	130	165	4.0	M10	19	40	21.8	6	72	74
PD/PM 32-33	90	200	130	165	4.0	M10	24	50	27.3	8	72	74
PD/PM 32-33	100	250	180	215	5.0	M12	28	60	31.3	8	75	131.5
PD/PM 32-33	112	250	180	215	5.0	M12	28	60	31.3	8	75	131.5
PD/PM 32	132	300	230	265	5.0	M12	38	80	41.3	10	94	-

~ Kg		
PAM B5	PD/PM 32	PD/PM 33
63	-	52
71	47	52
80	48	53
90	48	53
100	49	60
112	49	60
132	59	-

Tip / Type	PAM B14	Øa2	Øb2	Øe2	f2	Øs2	Ød1	l1	t1	u1	o (32)	o (33)
PD/PM 33	63	90	60	75	3.5	6	11	23	12.8	4	-	60
PD/PM 32-33	71	105	70	85	4	7	14	30	16.3	5	55	55
PD/PM 32-33	80	120	80	100	4	7	19	40	21.8	6	72	74
PD/PM 32-33	90	140	95	115	4	9	24	50	27.3	8	72	74
PD/PM 32-33	100	160	110	130	5	9	28	60	31.3	8	75	75
PD/PM 32-33	112	160	110	130	5	9	28	60	31.3	8	75	75
PD/PM 32	132	200	130	165	5	11	38	80	41.3	10	94	-

~ Kg		
PAM B14	PD/PM 32	PD/PM 33
63	-	51
71	45	51
80	46	52
90	46	52
100	48	53
112	48	53
132	52	-

PD 42

PD 42 B5

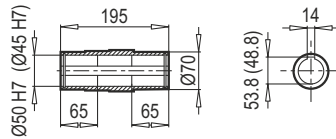
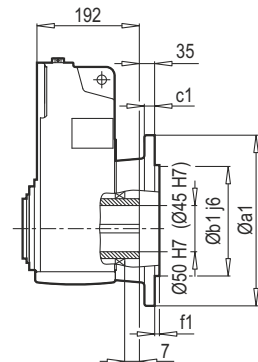
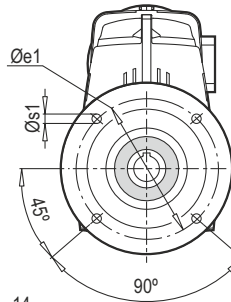
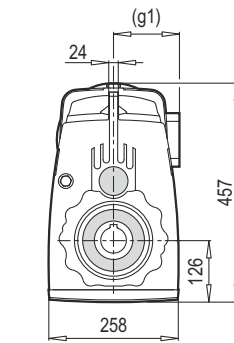
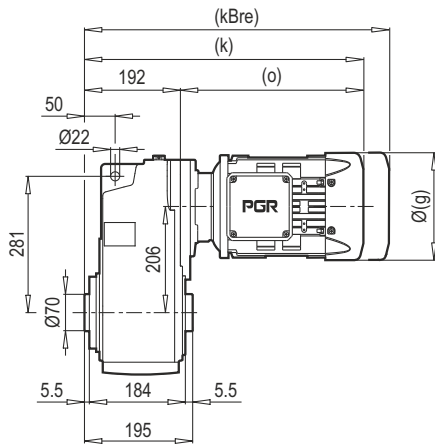

a1	b1	c1	e1	f1	s1
300	230	20	265	4	4x14

PM 42

PM 42 B5

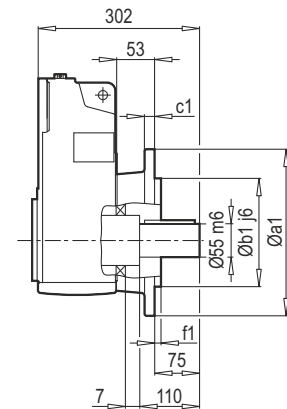
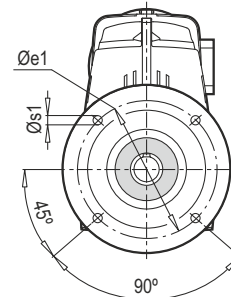
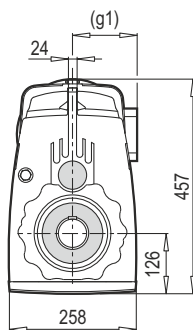
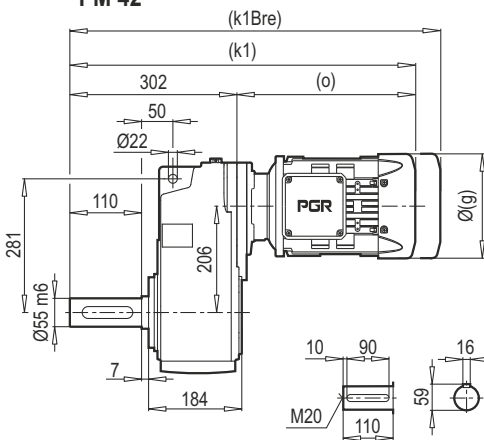

PD 42 KS

PD 42 DIN 5480

PD 42 Ç

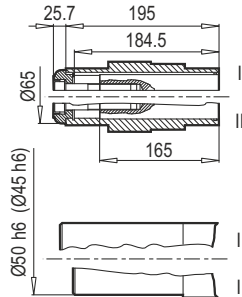
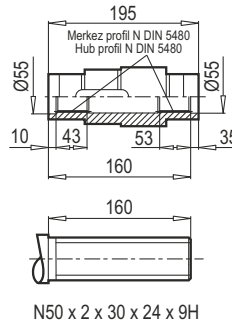
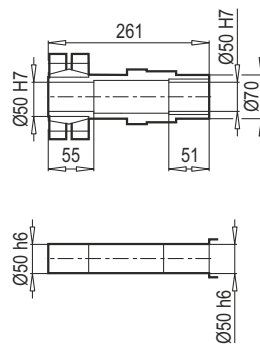
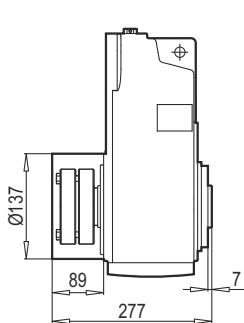

62 - 63

	90 S	90 L	100 L	112 M	132 S	132 M	160 M/L
g	193	193	217	232	279	279	323
g1	151	151	160	168	182	182	200
k/k1	457/567	477/587	505/615	550/660	557/667	592/702	697/807
kBre/k1Bre	530/640	550/660	586/696	630/740	665/775	733/843	849/959
o	265	285	313	358	365	400	505

Not : (...) İşaretli olan ölçüler Motor markasına göre farklılık gösterir / Note : Dimension which is designated by (...) depends on marks of motor.

PD 43

PD 43 B5

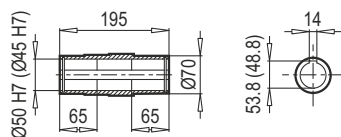
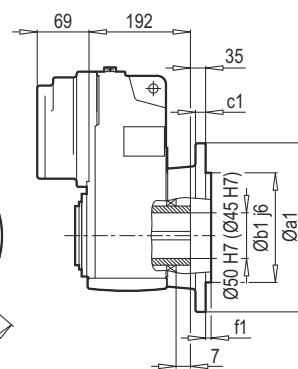
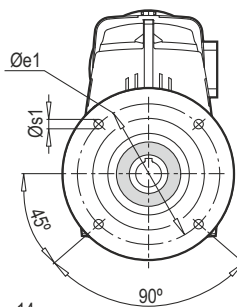
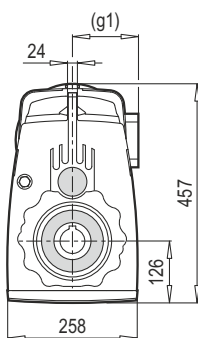
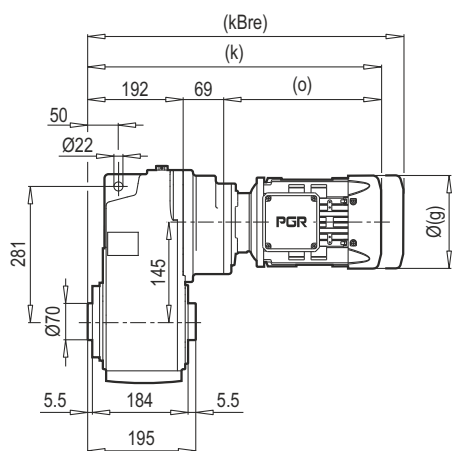

a1	b1	c1	e1	f1	s1
300	230	20	265	4	4x14

PM 43

PM 43 B5

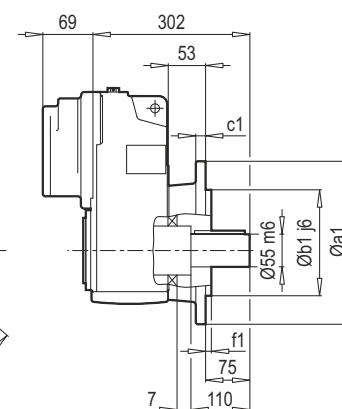
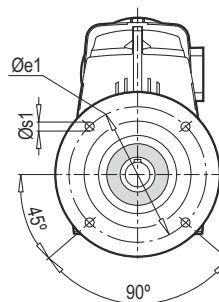
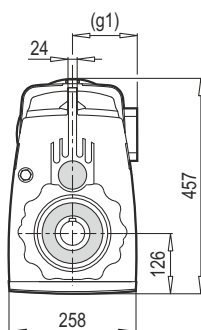
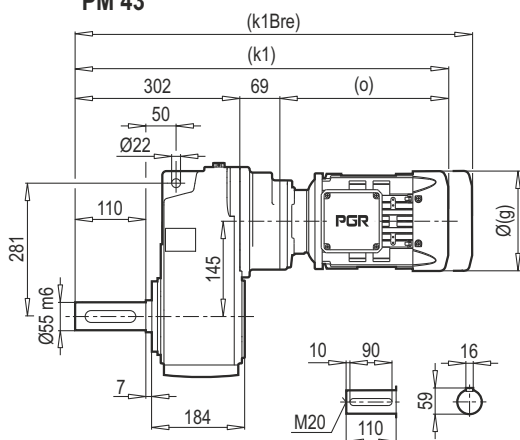

PD 43 DIN 5480

PD 43 Ç

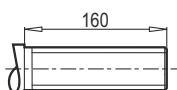
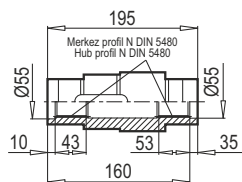

N50 x 2 x 30 x 24 x 9H

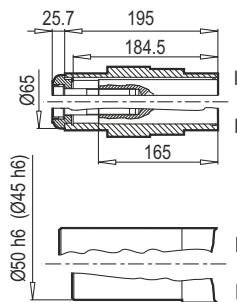

62 - 63

	71 M	80 M	90 S	90 L	100 L	112 M	
g	140	159	193	193	217	232	
g1	119	127	151	151	160	168	
k/k1	497/607	523/633	546/656	566/676	594/704	639/749	
kBre/k1Bre	557/667	585/695	619/729	639/749	675/785	719/829	
o	236	262	285	305	333	378	

Not : (...) İşaretli olan ölçüler Motor markasına göre farklılık gösterir / Note : Dimension which is designated by (...) depends on marks of motor.

PD/PM 42
PD/PM 43

PD 42
PD 43

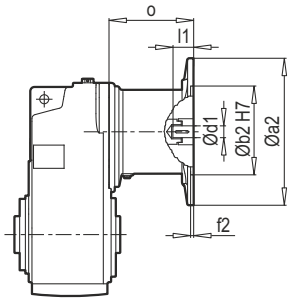

IEC

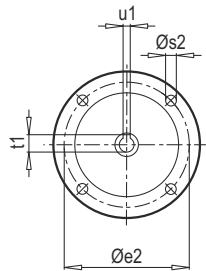

PM 42
PM 43

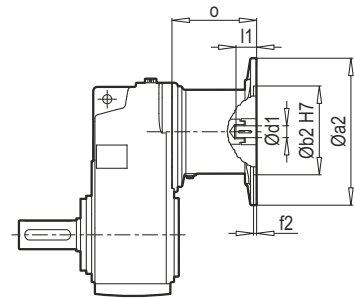

Tip / Type	IEC	Øa2	Øb2	Øe2	f2	Øs2	Ød1	l1	t1	u1	PD/PM 42 o	PD/PM 43 o
PD/PM 43	71	160	110	130	4	M8	14	30	16.3	5	-	88
PD/PM 43	80	200	130	165	4	M10	19	40	21.8	6	-	107
PD/PM 42-43	90	200	130	165	4	M10	24	50	27.3	8	109	107
PD/PM 42-43	100	250	180	215	5	M12	28	60	31.3	8	133	124
PD/PM 42-43	112	250	180	215	5	M12	28	60	31.3	8	133	124
PD/PM 42	132	300	230	265	5	M12	38	80	41.3	10	190	-
PD/PM 42	160	350	250	300	6	M16	42	110	45.3	12	194	-

~ Kg		
IEC	PD/PM 42	PD/PM 43
71	-	81
80	-	85
90	73	85
100	80	89
112	80	89
132	95	-
160	105	-

PD 42
PD 43

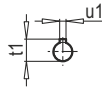
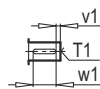
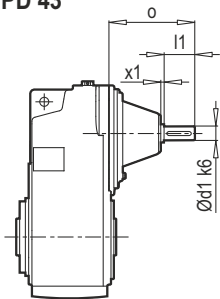

W

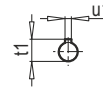
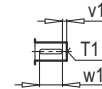
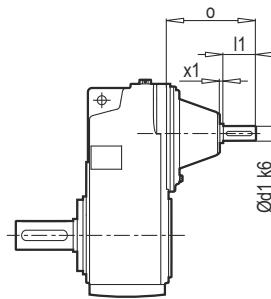

PM 42
PM 43

Tip / Type	Ød1	x1	l1	o	T1	t1	u1	v1	w1
PD/PM 42	38	8	80	213	M12	41	10	5	70
PD/PM 43	24	8	50	172	M8	27	8	5	40

~ Kg	
PD/PM 42	78
PD/PM 43	83

PD 42
PD 43

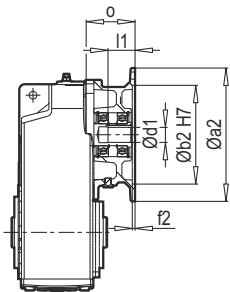

PAM B5/B14

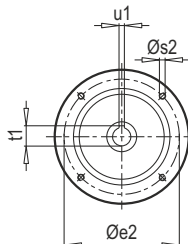

PM 42
PM 43

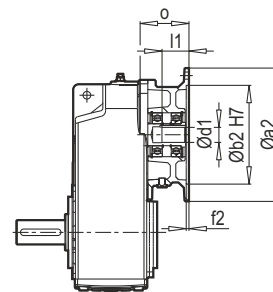

Tip / Type	PAM B5	Øa2	Øb2	Øe2	f2	Øs2	Ød1	l1	t1	u1	o
PD/PM 43	71	160	110	130	4.0	M8	14	30	16.3	5	88
PD/PM 43	80	200	130	165	4.0	M10	19	40	21.8	6	72
PD/PM 42-43	90	200	130	165	4.0	M10	24	50	27.3	8	72
PD/PM 42-43	100	250	180	215	5.0	M12	28	60	31.3	8	75
PD/PM 42-43	112	250	180	215	5.0	M12	28	60	31.3	8	75
PD/PM 42	132	300	230	265	5.0	M12	38	80	41.3	10	94
PD/PM 42	160	350	250	300	6.0	M16	42	110	45.3	12	120

~ Kg		
PAM B5	PD/PM 42	PD/PM 43
71	-	77
80	-	78
90	66	78
100	67	79
112	67	79
132	76	-
160	84	-

Tip / Type	PAM B14	Øa2	Øb2	Øe2	f2	Øs2	Ød1	l1	t1	u1	o
PD/PM 43	71	105	70	85	4	7	14	30	16.3	5	55
PD/PM 43	80	120	80	100	4	7	19	40	21.8	6	72
PD/PM 42-43	90	140	95	115	4	9	24	50	27.3	8	72
PD/PM 42-43	100	160	110	130	5	9	28	60	31.3	8	75
PD/PM 42-43	112	160	110	130	5	9	28	60	31.3	8	75
PD/PM 42	132	200	130	165	5	11	38	80	41.3	10	94

~ Kg		
PAM B14	PD/PM 42	PD/PM 43
71	-	75
80	-	76
90	65	76
100	66	78
112	66	78
132	71	-

PD 52

PD 52 B5

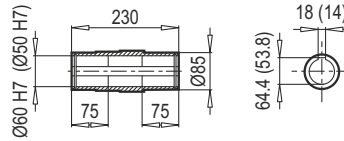
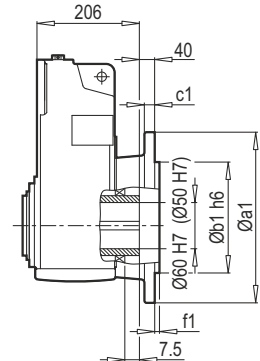
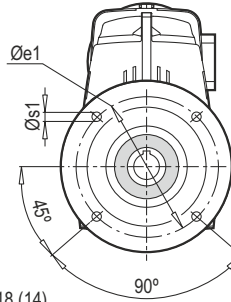
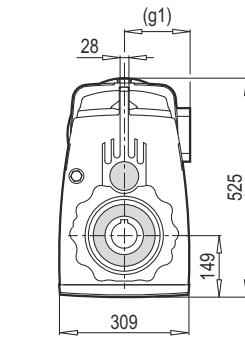
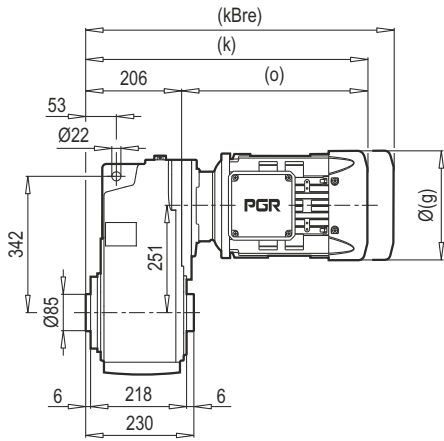

a1	b1	c1	e1	f1	s1
350	250	20	300	5	4x18

PM 52

PM 52 B5

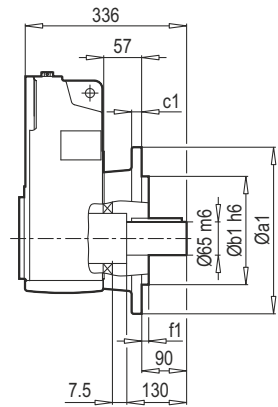
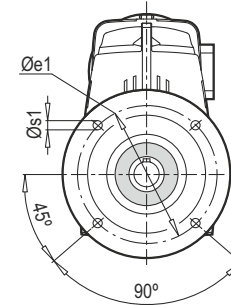
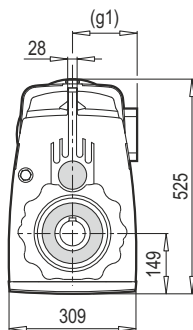
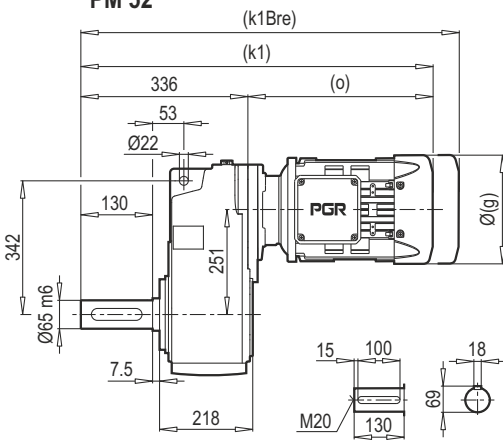

PD 52 KS

PD 52 DIN 5480

PD 52 Ç

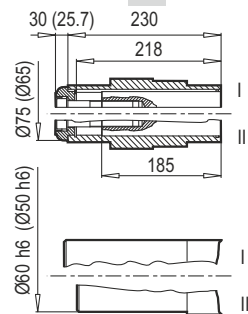
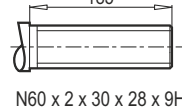
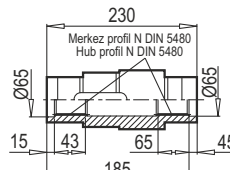
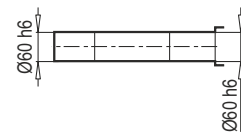
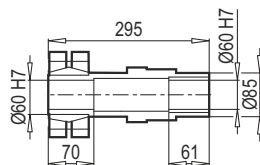
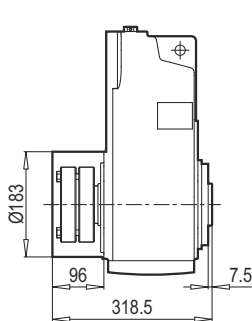

62 - 63

	90 S	90 L	100 L	112 M	132 S	132 M	160 M/L	180 M/L
g	193	193	217	232	279	279	323	370
g1	151	151	160	168	182	182	200	248
k/k1	471/601	491/621	519/649	564/694	571/701	606/736	711/841	785/915
kBre/k1Bre	544/674	564/694	600/730	644/774	679/809	747/877	863/993	947/1077
o	265	285	313	358	365	400	505	579

Not : (...) işaretli olan ölçüler Motor markasına göre farklılık gösterir / Note : Dimension which is designated by (...) depends on marks of motor.

PD 53

PD 53 B5

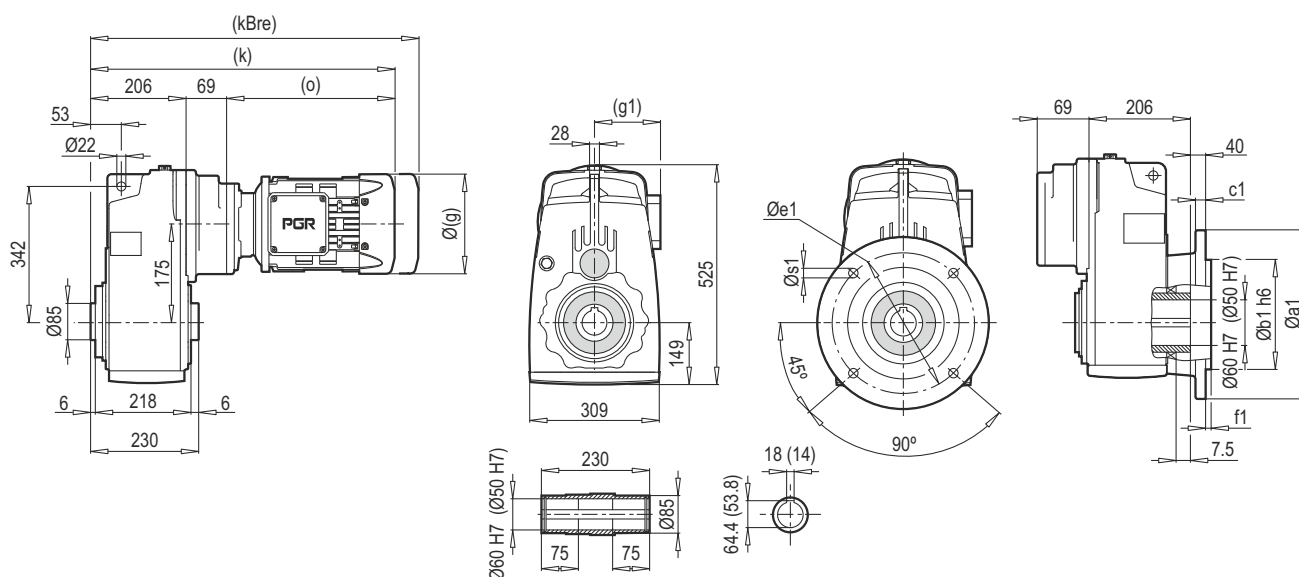

a1	b1	c1	e1	f1	s1
350	250	20	300	5	4x18

PM 53

PM 53 B5

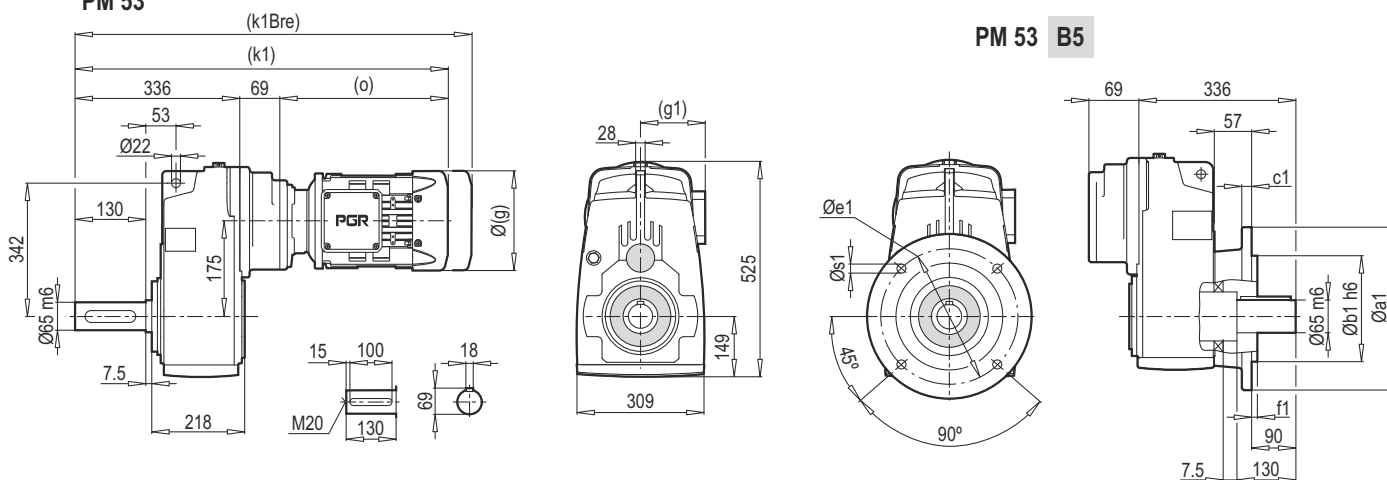

PD 53 DIN 5480

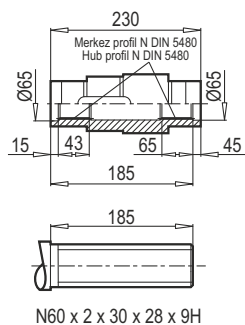

PD 53 Ç

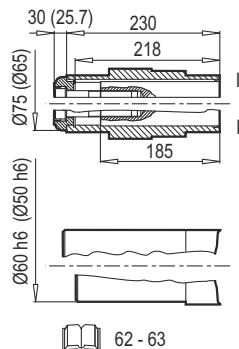

	80 M	90 S	90 L	100 L	112 M		
g	159	193	193	217	232		
g1	127	151	151	160	168		
k/k1	537/667	560/690	580/710	608/738	653/783		
kBre/k1Bre	599/729	633/763	653/783	689/819	733/863		
o	262	285	305	333	378		

Not : (...) İşaretli olan ölçüler Motor markasına göre farklılık gösterir / Note : Dimension which is designated by (...) depends on marks of motor.

PD/PM 52
PD/PM 53

PD 52
PD 53

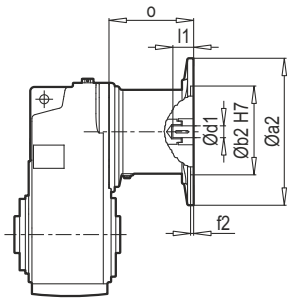

IEC

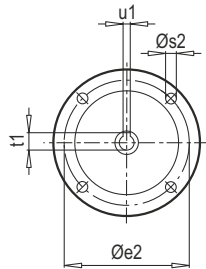

PM 52
PM 53

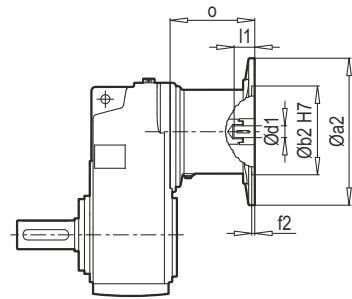

Tip / Type	IEC	Øa2	Øb2	Øe2	f2	Øs2	Ød1	l1	t1	u1	PD/PM 52 o	PD/PM 53 o
PD/PM 53	71	160	110	130	4.0	M8	14	30	16.3	5	-	88
PD/PM 53	80	200	130	165	4.0	M10	19	40	21.8	6	-	107
PD/PM 52-53	90	200	130	165	4.0	M10	24	50	27.3	8	109	107
PD/PM 52-53	100	250	180	215	5.0	M12	28	60	31.3	8	133	124
PD/PM 52-53	112	250	180	215	5.0	M12	28	60	31.3	8	133	124
PD/PM 52	132	300	230	265	5.0	M12	38	80	41.3	10	190	-
PD/PM 52	160	350	250	300	6.0	M16	42	110	45.3	12	194	-
PD/PM 52	180	350	250	300	6.0	M16	48	110	51.8	14	194	-

~ Kg		
IEC	PD/PM 52	PD/PM 53
71	-	124
80	-	128
90	111	128
100	119	132
112	119	132
132	133	-
160	144	-
180	144	-

PD 52
PD 53

W

PM 52
PM 53

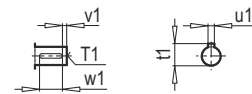
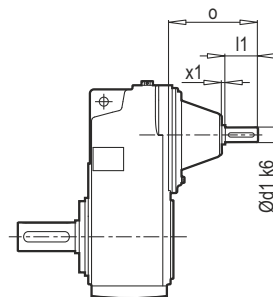
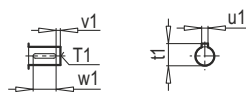
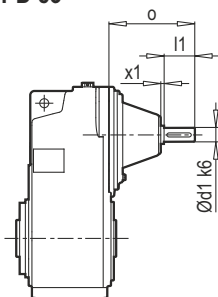

Tip / Type	Ød1	x1	l1	o	T1	t1	u1	v1	w1
PD/PM 52	38	8	80	213	M12	41	10	5	70
PD/PM 53	24	8	50	172	M8	27	8	5	40

~ Kg	
PD/PM 52	PD/PM 53
117	126

PD 52
PD 53

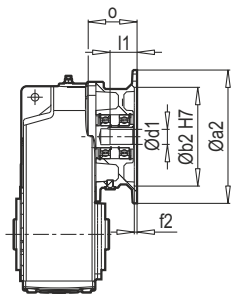

PAM B5/B14

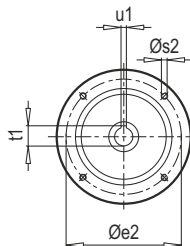

PM 52
PM 53

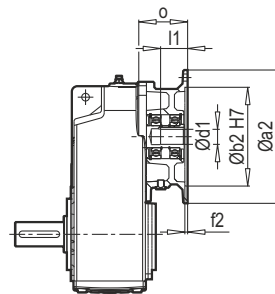

Tip / Type	PAM B5	Øa2	Øb2	Øe2	f2	Øs2	Ød1	l1	t1	u1	o
PD/PM 53	71	160	110	130	4.0	M8	14	30	16.3	5	88
PD/PM 53	80	200	130	165	4.0	M10	19	40	21.8	6	72
PD/PM 52-53	90	200	130	165	4.0	M10	24	50	27.3	8	72
PD/PM 52-53	100	250	180	215	5.0	M12	28	60	31.3	8	75
PD/PM 52-53	112	250	180	215	5.0	M12	28	60	31.3	8	75
PD/PM 52	132	300	230	265	5.0	M12	38	80	41.3	10	94
PD/PM 52	160	350	250	300	6.0	M16	42	110	45.3	12	120
PD/PM 52	180	350	250	300	6.0	M16	48	110	51.8	14	120

~ Kg		
PAM B5	PD/PM 52	PD/PM 53
71	-	117
80	-	118
90	102	118
100	103	119
112	103	119
132	112	-
160	120	-
180	120	-

Tip / Type	PAM B14	Øa2	Øb2	Øe2	f2	Øs2	Ød1	l1	t1	u1	o
PD/PM 53	71	105	70	85	4.0	7	14	30	16.3	5	55
PD/PM 53	80	120	80	100	4.0	7	19	40	21.8	6	72
PD/PM 52-53	90	140	95	115	4.0	9	24	50	27.3	8	72
PD/PM 52-53	100	160	110	130	5.0	9	28	60	31.3	8	75
PD/PM 52-53	112	160	110	130	5.0	9	28	60	31.3	8	75
PD/PM 52	132	200	130	165	5.0	11	38	80	41.3	10	94

~ Kg		
PAM B5	PD/PM 52	PD/PM 53
71	-	115
80	-	116
90	101	116
100	102	118
112	102	118
132	107	-

PD 62

PD 62 B5

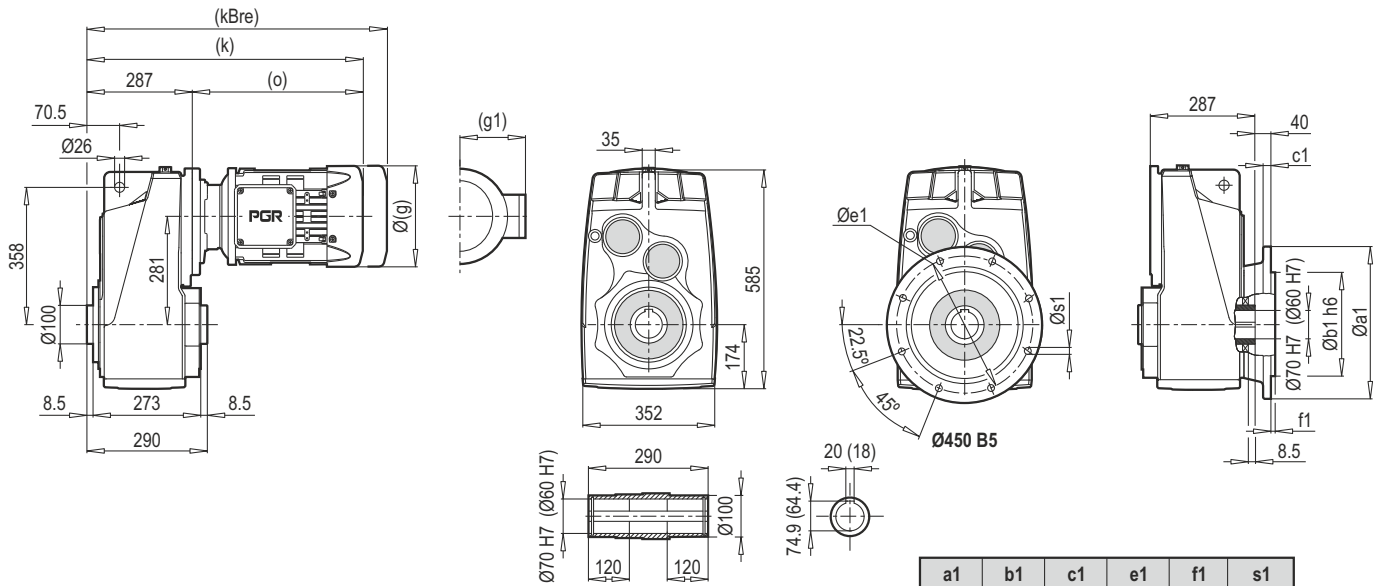

a1	b1	c1	e1	f1	s1
400	300	20	350	5	4x18
450	350	22	400	5	8x18

PM 62

PM 62 B5

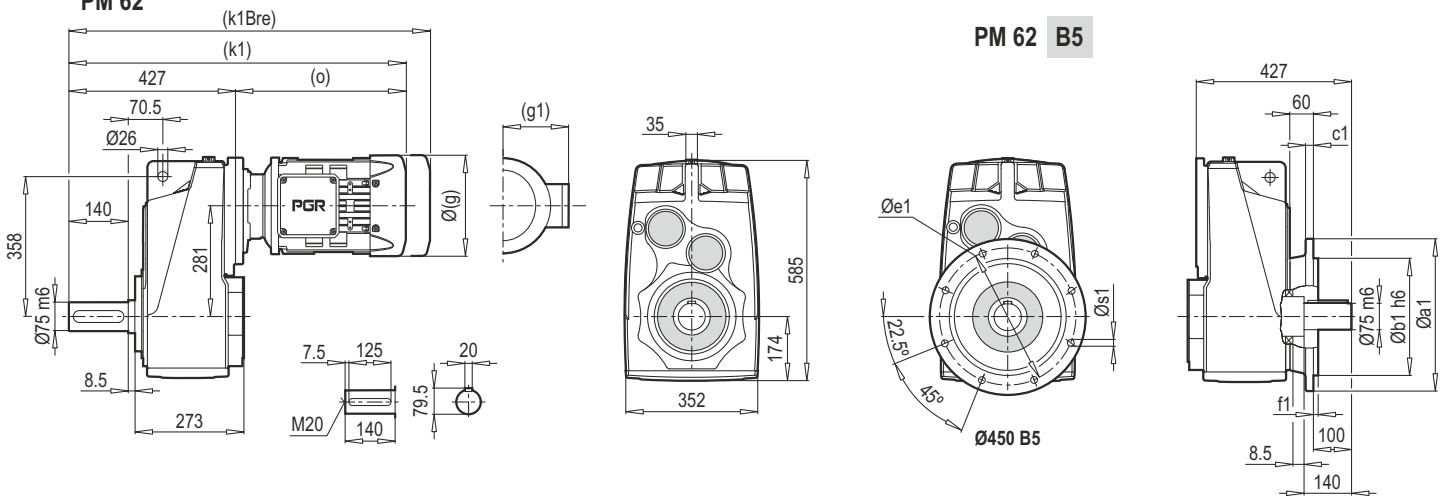

PD 62 KS

PD 62 DIN 5480

PD 62 Ç

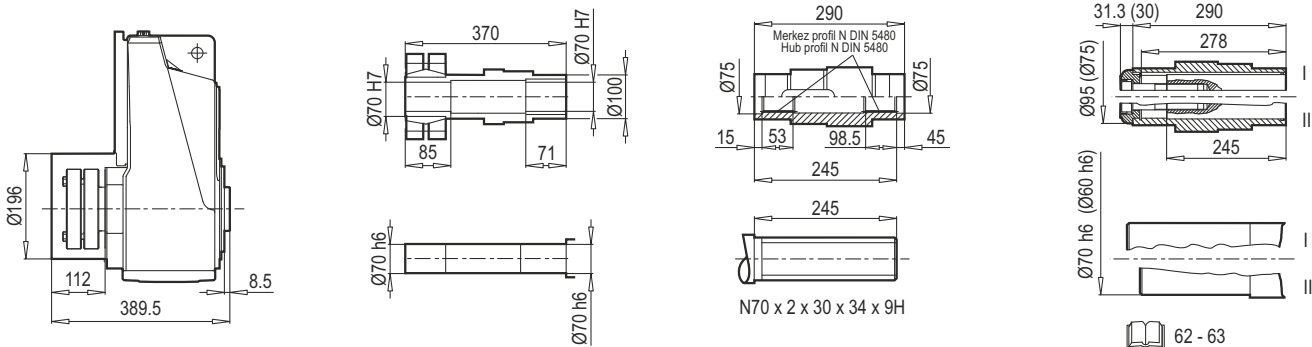

62 - 63

	100 L	112 M	132 S	132 M	160 M/L	180 M/L	200 L	225 S/M
g	217	232	279	279	323	370	415	456
g1	160	168	182	182	200	248	260	260
k/k1	599/740	647/788	650/791	685/826	751/892	810/951	905/1046	987/1128
kBre/k1Bre	680/821	727/868	758/899	826/967	903/1044	972/1113	1052/1193	1159/1300
o	312	360	363	398	464	523	618	700

Not : (...) İşaretili olan ölçüler Motor markasına göre farklılık gösterir / Note : Dimension which is designated by (...) depends on marks of motor.

PD 63

PD 63 B5

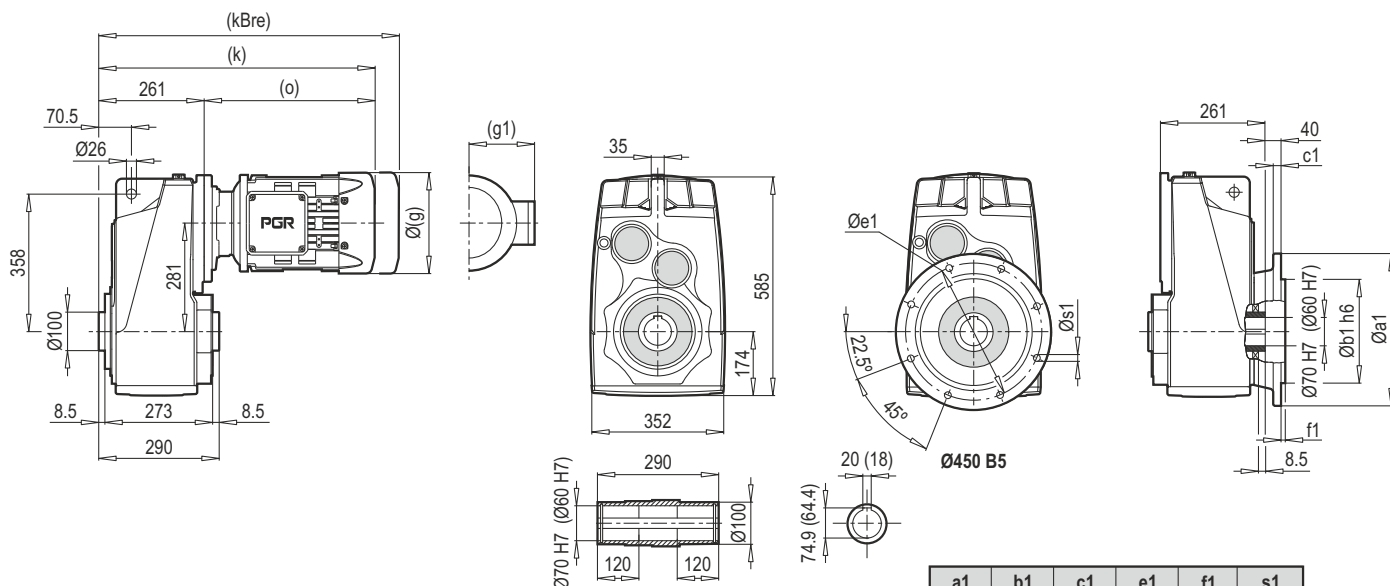

a1	b1	c1	e1	f1	s1
400	300	20	350	5	4x18
450	350	22	400	5	8x18

PM 63

PM 63 B5

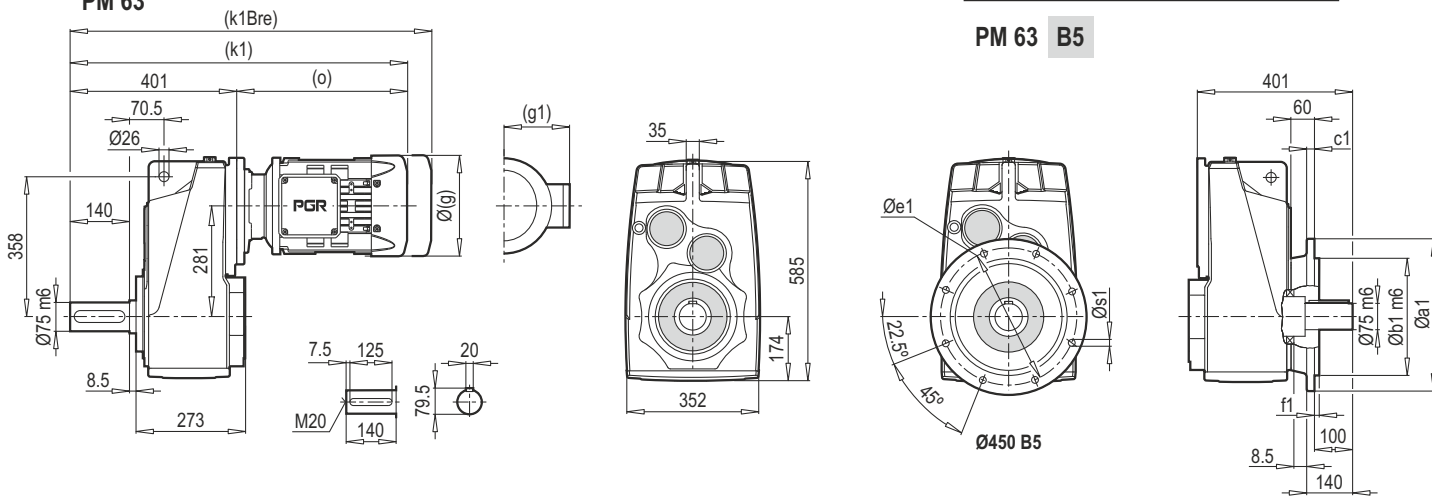

PD 63 KS

PD 63 DIN 5480

PD 63 Ç

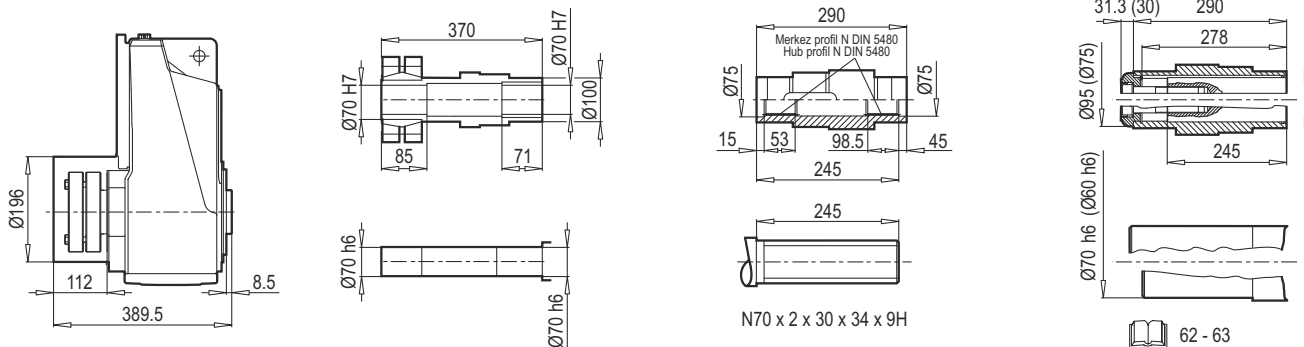

	90 S	90 L	100 L	112 M	132 S	132 M	160 M/L	180 M/L
g	193	193	217	232	279	279	323	370
g1	151	151	160	168	182	182	200	248
k/k1	526/666	546/686	574/714	619/759	626/766	661/801	766/906	840/980
kBre/k1Bre	599/739	619/759	655/795	699/839	734/874	802/942	918/1058	1002/1142
o	265	285	313	358	365	400	505	579

Not : (... İşaretili olan ölçüler Motor markasına göre farklılık gösterir / Note : The dimensions which have (...) sign vary depending on the motor brand.

PD/PM 62
PD/PM 63

PD 62
PD 63

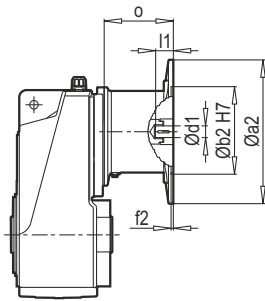

IEC

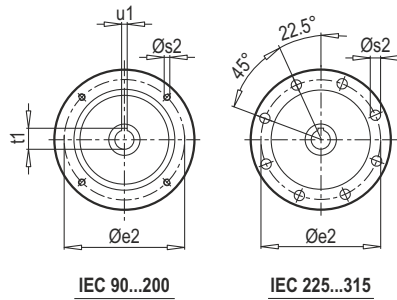

PM 62
PM 63

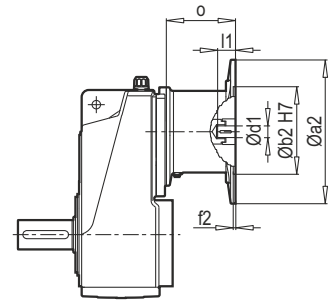

Tip / Type	IEC	Øa2	Øb2	Øe2	f2	Øs2	Ød1	l1	t1	u1	PD/PM 62 o	PD/PM 63 o
PD/PM 63	90	200	130	165	4.0	M10	24	50	27.3	8	-	109
PD/PM 62-63	100	250	180	215	5.0	M12	28	60	31.3	8	127	133
PD/PM 62-63	112	250	180	215	5.0	M12	28	60	31.3	8	127	133
PD/PM 62-63	132	300	230	265	5.0	M12	38	80	41.3	10	177	190
PD/PM 62-63	160	350	250	300	6.0	M16	42	110	45.3	12	266	194
PD/PM 62-63	180	350	250	300	6.0	M16	48	110	51.8	14	266	194
PD/PM 62	200	400	300	350	6.0	M16	55	110	59.3	16	229	-
PD/PM 62	225	450	350	400	6.0	M16	60	140	64.4	18	303	-

~ Kg		
IEC	PD/PM 62	PD/PM 63
90	-	196
100	213	204
112	213	204
132	227	218
160	253	229
180	253	229
200	268	-
225	284	-

PD 62
PD 63

W

PM 62
PM 63

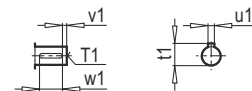
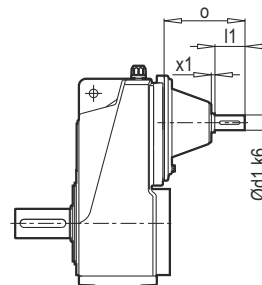
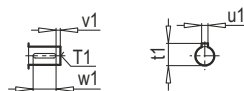
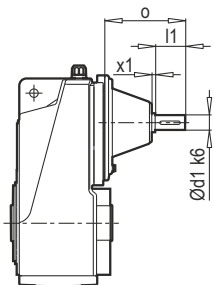

Tip / Type	Ød1	x1	l1	o	T1	t1	u1	v1	w1
PD/PM 62	42	8	110	288	M16	45	12	10	90
PD/PM 63	38	8	80	213	M12	41	10	5	70

~ Kg	
PD/PM 62	226
PD/PM 63	202

PD 62
PD 63

PAM B5/B14

PM 62
PM 63

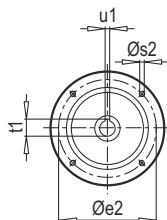
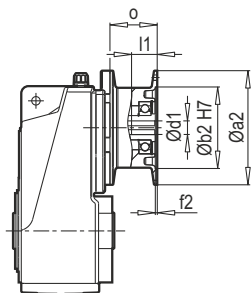

PAM 90...200

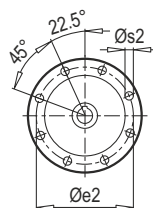

PAM 225...315

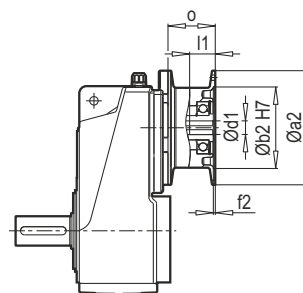

Tip / Type	PAM B5	Øa2	Øb2	Øe2	f2	Øs2	Ød1	l1	t1	u1	o (62)	o (63)
PD/PM 63	90	200	130	165	4.0	M10	24	50	27.3	8	-	72
PD/PM 62-63	100	250	180	215	5.0	M12	28	60	31.3	8	75	75
PD/PM 62-63	112	250	180	215	5.0	M12	28	60	31.3	8	75	75
PD/PM 62-63	132	300	230	265	5.0	M12	38	80	41.3	10	110	94
PD/PM 62-63	160	350	250	300	6.0	M16	42	110	45.3	12	145	120
PD/PM 62-63	180	350	250	300	6.0	M16	48	110	51.8	14	145	120
PD/PM 62	200	400	300	350	6.0	M16	55	110	59.3	16	157	-
PD/PM 62	225	450	350	400	6.0	M16	60	140	64.4	18	183	-

~ Kg		
PAM B5	PD/PM 62	PD/PM 63
90	-	183
100	190	184
112	190	184
132	201	193
160	218	201
180	218	201
200	225	-
225	225	-

Tip / Type	PAM B14	Øa2	Øb2	Øe2	f2	Øs2	Ød1	l1	t1	u1	o (62)	o (63)
PD/PM 63	90	140	95	115	4.0	9	24	50	27.3	8	75	75
PD/PM 62-63	100	160	110	130	5.0	9	28	60	31.3	8	75	75
PD/PM 62-63	112	160	110	130	5.0	9	28	60	31.3	8	110	94
PD/PM 62-63	132	200	130	165	5.0	11	38	80	41.3	10	110	94

~ Kg		
PAM B14	PD/PM 62	PD/PM 63
90	-	182
100	189	183
112	189	183
132	196	188

PD 72

PD 72 B5

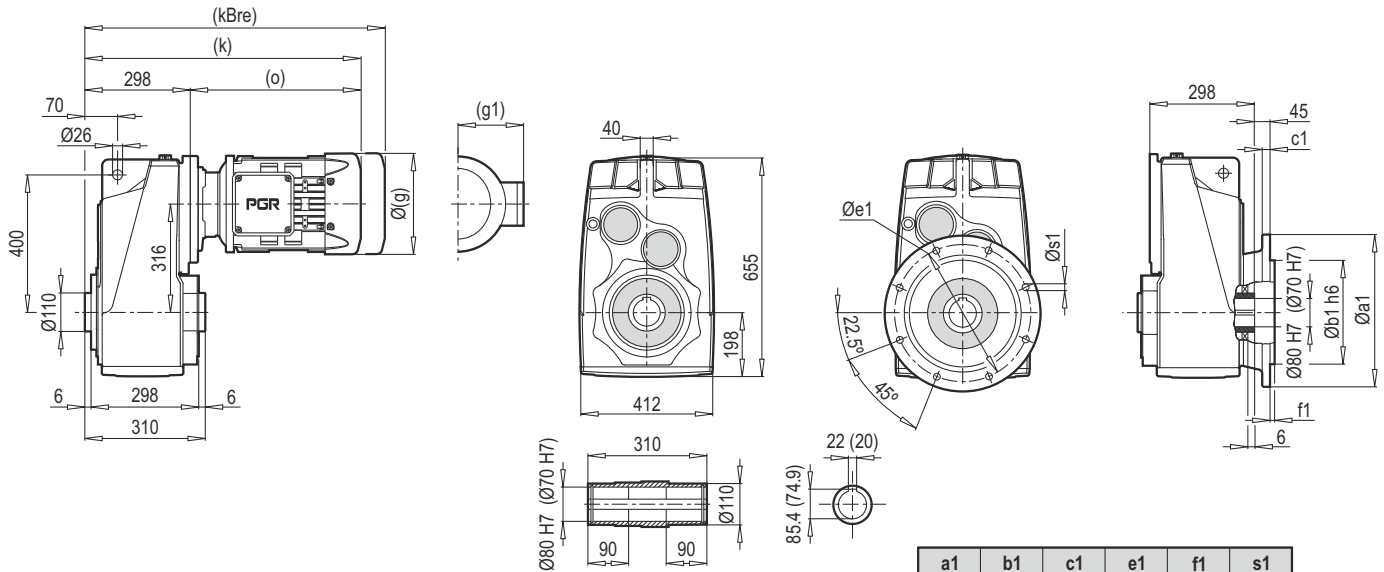

a1	b1	c1	e1	f1	s1
450	350	22	400	5	8x18
550	450	28	500	5	8x18

PM 72

PM 72 B5

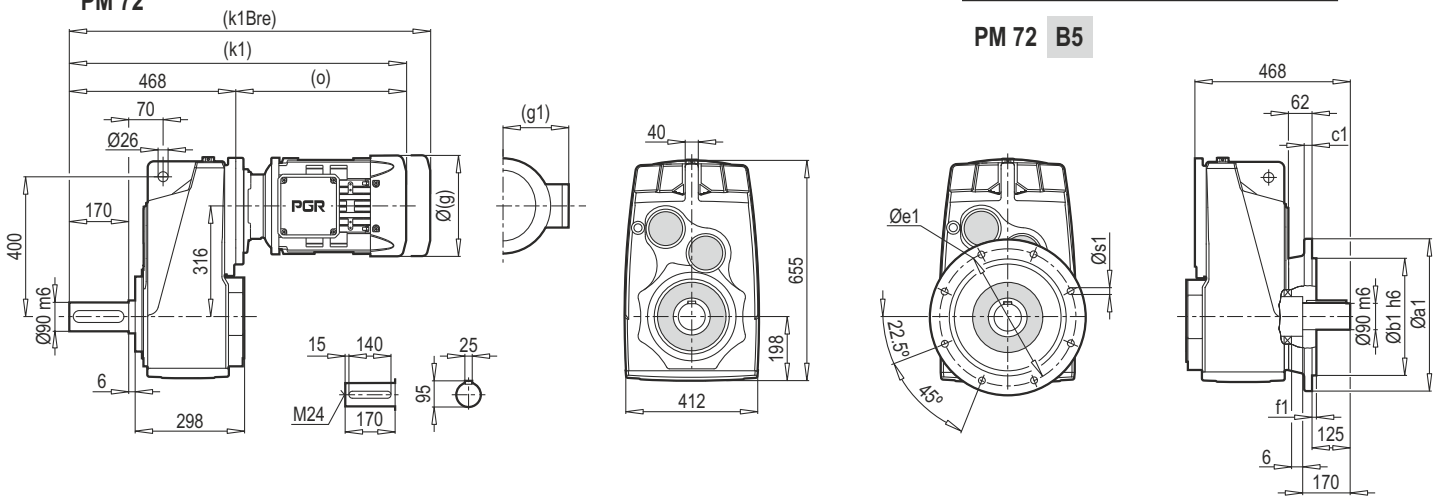

PD 72 KS

PD 72 DIN 5480

PD 72 Ç

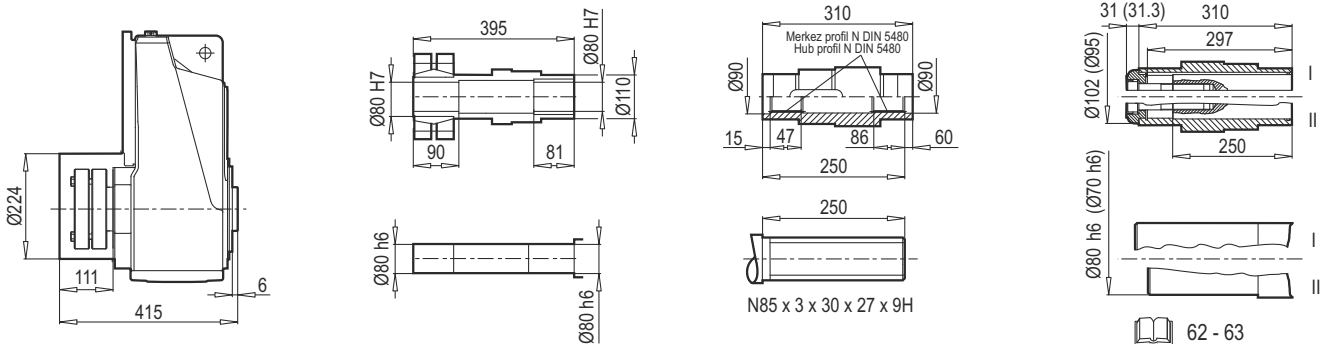

	132 M	160 M/L	180 M/L	200 L	225 S/M		
g	279	323	370	415	456		
g1	182	200	248	260	260		
k/k1	696/866	762/932	821/991	916/1086	998/1168		
kBre/k1Bre	837/1007	914/1084	983/1153	1063/1233	1170/1340		
o	398	464	523	618	700		

Not : (...) İşaretli olan ölçüler Motor markasına göre farklılık gösterir / Note : The dimensions which have (...) sign vary depending on the motor brand.

PD 73

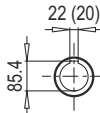
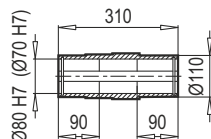
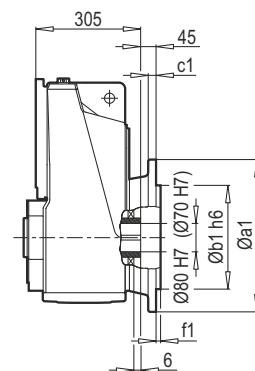
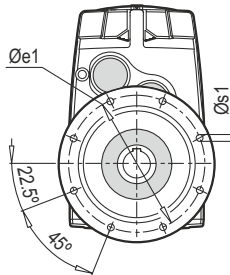
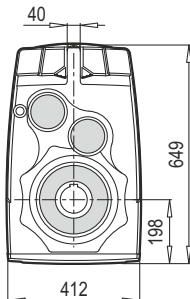
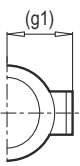
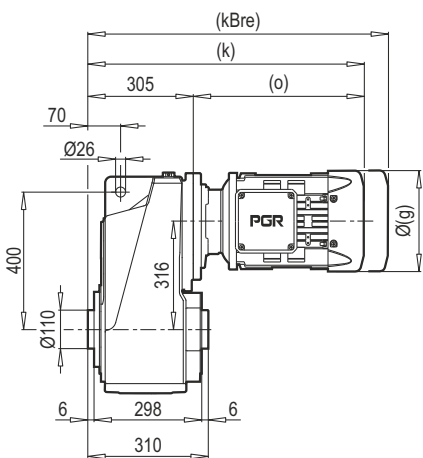

PD 73 B5

a1	b1	c1	e1	f1	s1
450	350	22	400	5	8x18
550	450	28	500	5	8x18

PM 73

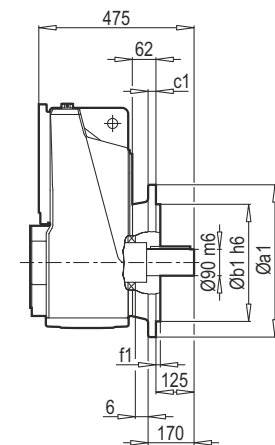
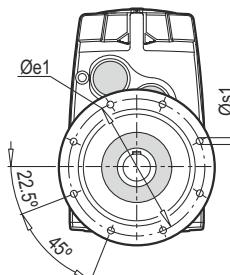
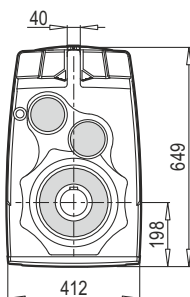
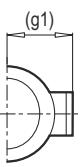
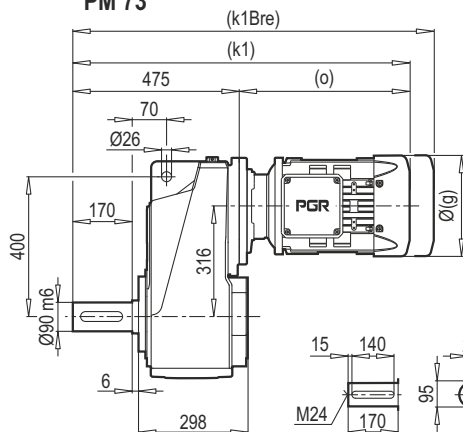

PM 73 B5

PD 73 KS

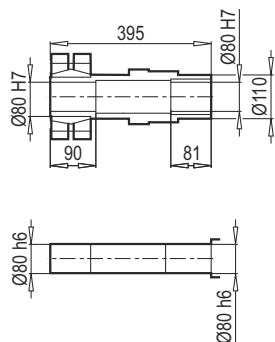
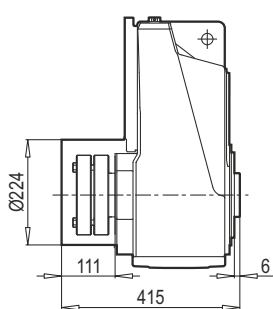

PD 73 DIN 5480

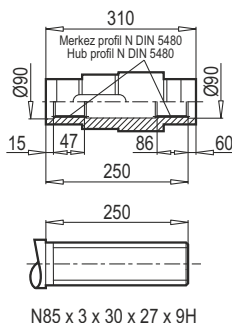

PD 73 Ç

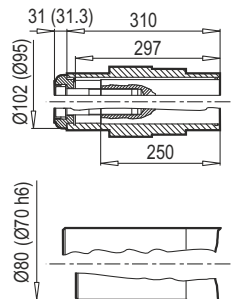

62 - 63

	100 L	112 M	132 S	132 M	160 M/L	180 M/L	200 L	225 S/M
g	217	232	279	279	323	370	415	456
g1	160	168	182	182	200	248	260	260
k/k1	617/787	665/835	668/838	703/873	769/939	828/998	923/1093	1005/1175
kBre/k1Bre	698/868	745/915	776/946	844/1014	921/1091	990/1160	1070/1240	1177/1347
o	312	360	363	398	464	523	618	700

Not : (...) İşaretli olan ölçüler Motor markasına göre farklılık gösterir / Note : The dimensions which have (...) sign vary depending on the motor brand.

PD/PM 72
PD/PM 73

PD 72
PD 73

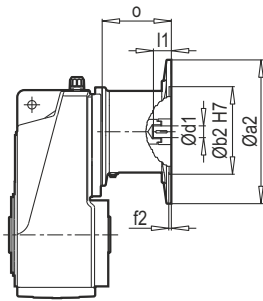

IEC

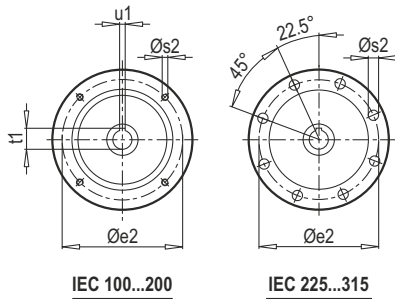

IEC 100...200

IEC 225...315

PM 72
PM 73

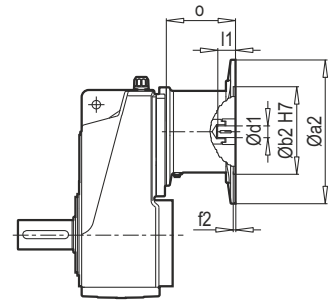

Tip / Type	IEC	Øa2	Øb2	Øe2	f2	Øs2	Ød1	l1	t1	u1	o
PD/PM 73	100	250	180	215	5.0	M12	28	60	31.3	8	127
PD/PM 73	112	250	180	215	5.0	M12	28	60	31.3	8	127
PD/PM 72-73	132	300	230	265	5.0	M12	38	80	41.3	10	177
PD/PM 72-73	160	350	250	300	6.0	M16	42	110	45.3	12	266
PD/PM 72-73	180	350	250	300	6.0	M16	48	110	51.8	14	266
PD/PM 72-73	200	400	300	350	6.0	M16	55	110	59.3	16	229
PD/PM 72-73	225	450	350	400	6.0	M16	60	140	64.4	18	303

~ Kg		
IEC	PD/PM 72	PD/PM 73
100	-	287
112	-	287
132	293	300
160	319	327
180	319	327
200	334	341
225	350	357

PD 72
PD 73

W

PM 72
PM 73

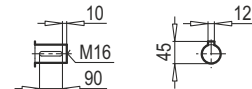
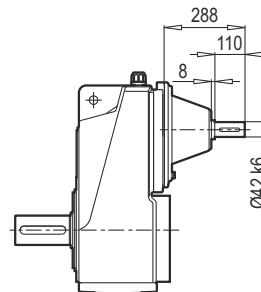
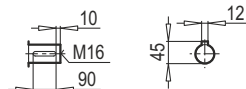
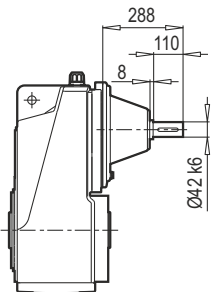

~ Kg	
PD/PM 72	292
PD/PM 73	299

PD 72
PD 73

PAM B5/B14

PM 72
PM 73

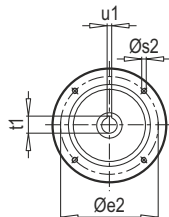
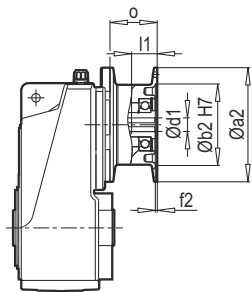

PAM 90...200

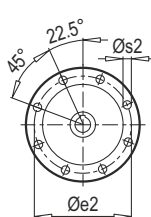

PAM 225...315

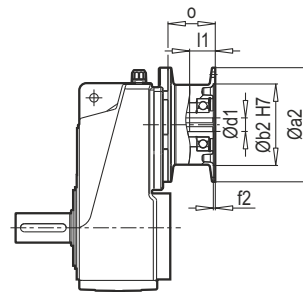

Tip / Type	PAM B5	Øa2	Øb2	Øe2	f2	Øs2	Ød1	l1	t1	u1	o
PD/PM 73	100	250	180	215	5.0	M12	28	60	31.3	8	75
PD/PM 73	112	250	180	215	5.0	M12	28	60	31.3	8	75
PD/PM 72-73	132	300	230	265	5.0	M12	38	80	41.3	10	110
PD/PM 72-73	160	350	250	300	6.0	M16	42	110	45.3	12	145
PD/PM 72-73	180	350	250	300	6.0	M16	48	110	51.8	14	145
PD/PM 72-73	200	400	300	350	6.0	M16	55	110	59.3	16	157
PD/PM 72-73	225	450	350	400	6.0	M16	60	140	64.4	18	183

~ Kg		
PAM B5	PD/PM 72	PD/PM 73
100	-	260
112	-	260
132	264	271
160	281	288
180	281	288
200	288	295
225	298	305

Tip / Type	PAM B14	Øa2	Øb2	Øe2	f2	Øs2	Ød1	l1	t1	u1	o
PD/PM 73	100	160	110	130	5.0	9	28	60	31.3	8	75
PD/PM 73	112	160	110	130	5.0	9	28	60	31.3	8	75
PD/PM 72-73	132	200	130	165	5.0	11	38	80	41.3	10	110

~ Kg		
PAM B14	PD/PM 72	PD/PM 73
100	-	259
112	-	259
132	259	266

PD 82

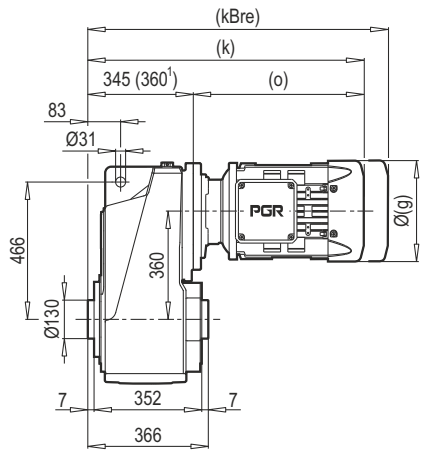

dH	Ø 100	(Ø 95)	(Ø 90)	(Ø 85)	(Ø 80)
uH	28	(25)	(25)	(22)	(22)
tH	106.4	(100.4)	(95.4)	(90.4)	(85.4)

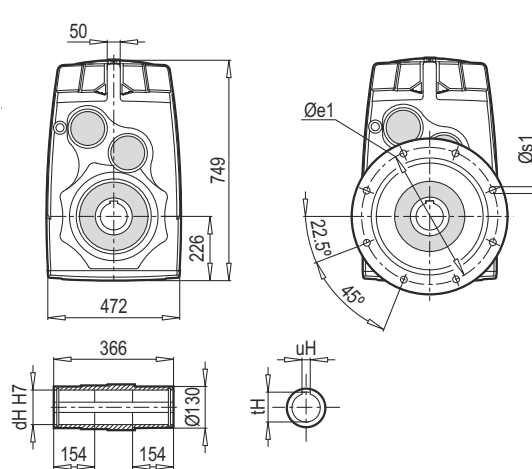

PD 82 B5

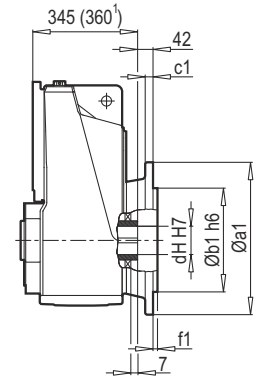

a1	b1	c1	e1	f1	s1
550	450	28	500	5	8x18

PM 82

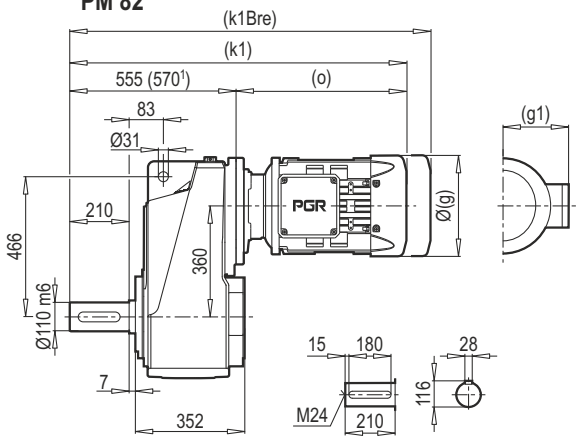

PM 82 B5

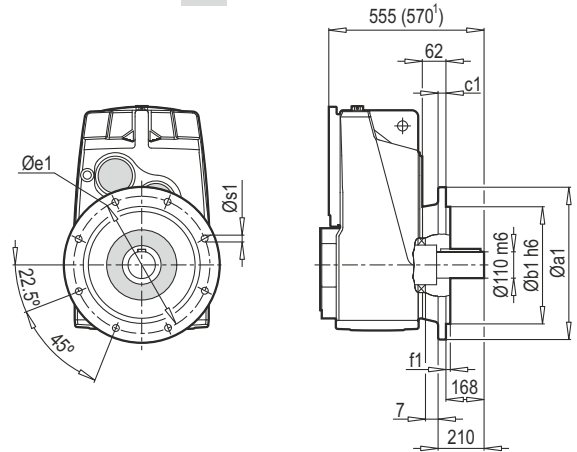

PD 82 KS

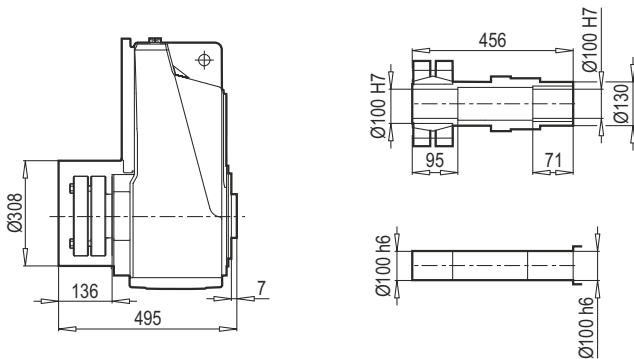

PD 82 DIN 5480

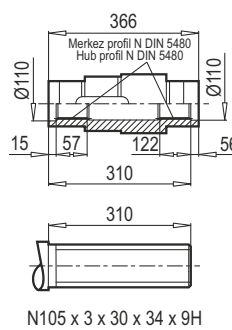

PD 82 Ç

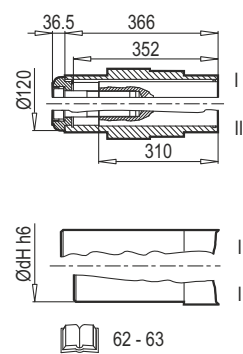

	132 M	160 M/L	180 M/L	200 L	225 S/M	250 M ¹⁾	280 S ¹⁾
g	279	323	370	415	456	495	527
g1	182	200	248	260	260	392	367
k/k1	743/953	809/1019	868/1078	963/1173	1045/1255	1004/1214	1259/1469
kBre/k1Bre	884/1094	961/1171	1030/1240	1110/1320	1217/1427	1134/1344	-
o	398	464	523	618	700	644	914

Not : (...) İşaretli olan ölçüler Motor markasına göre farklılık gösterir / Note : The dimensions which have (...) sign vary depending on the motor brand.

PD 83

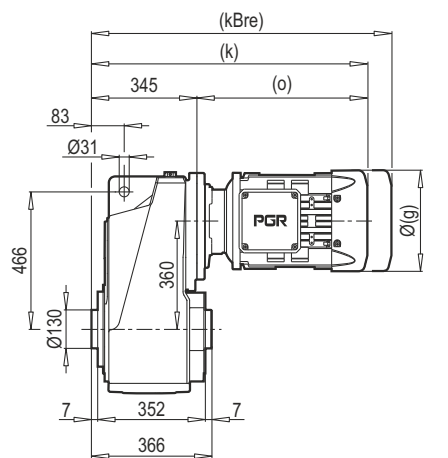

dH	Ø 100	(Ø 95)	(Ø 90)	(Ø 85)	(Ø 80)
uH	28	(25)	(25)	(22)	(22)
tH	106.4	(100.4)	(95.4)	(90.4)	(85.4)

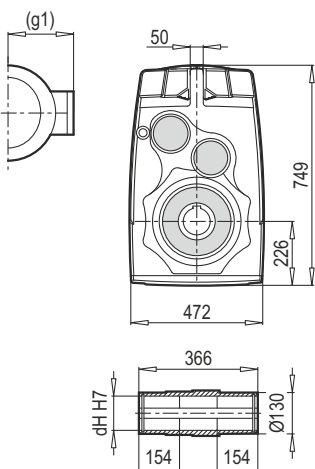

PD 83 B5

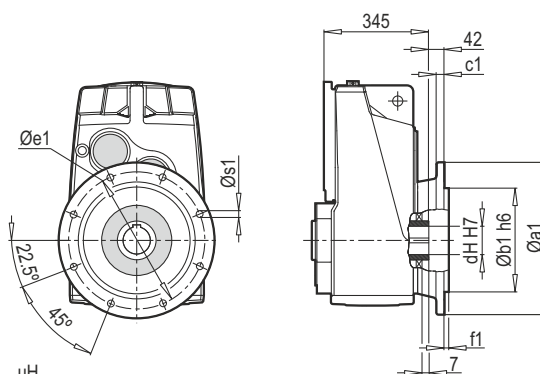

a1	b1	c1	e1	f1	s1
550	450	28	500	5	8x18

PM 83

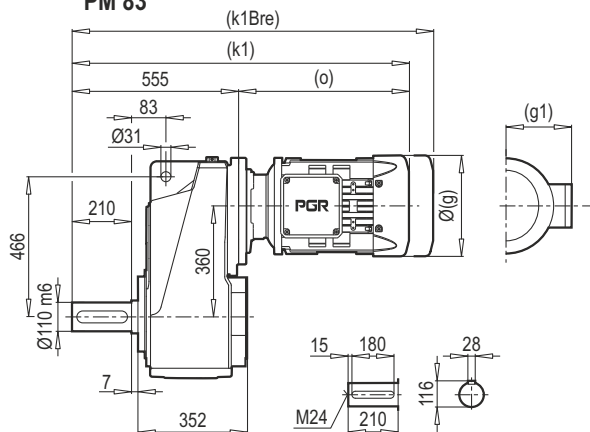

PM 83 B5

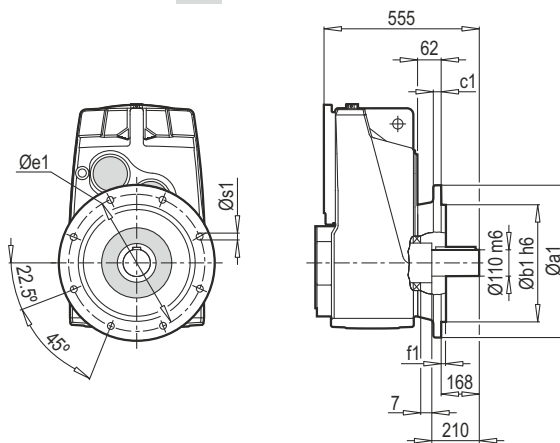

PD 83 KS

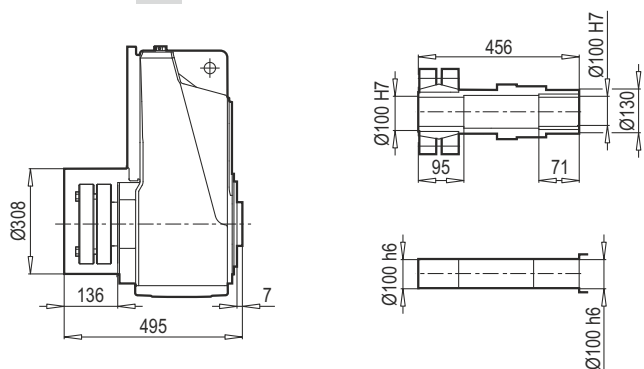

PD 83 DIN 5480

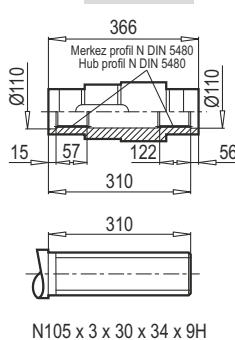

N105 x 3 x 30 x 34 x 9H

PD 83 Ç

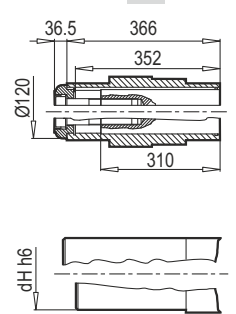

62 - 63

	100 L	112 M	132 S	132 M	160 M/L	180 M/L	200 L	225 S/M
g	217	232	279	279	323	370	415	456
g1	160	168	182	182	200	248	260	260
k/k1	657/867	705/915	708/918	743/953	809/1019	868/1078	963/1173	1045/1255
kBre/k1Bre	738/948	785/995	816/1026	884/1094	961/1171	1030/1240	1110/1320	1217/1427
o	312	360	363	398	464	523	618	700

Not : (...) İşaretli olan ölçüler Motor markasına göre farklılık gösterir / Note : The dimensions which have (...) sign vary depending on the motor brand.

PD/PM 82
PD/PM 83

PD 82
PD 83

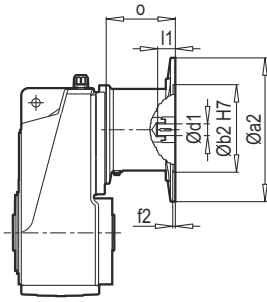

IEC

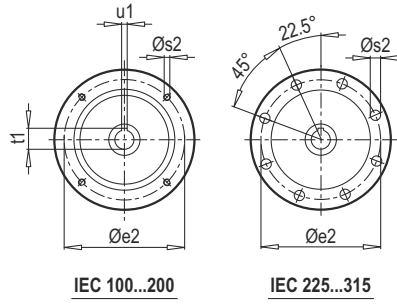

PM 82
PM 83

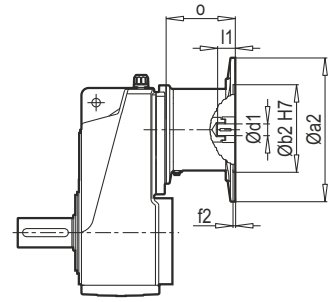

Tip / Type	IEC	Øa2	Øb2	Øe2	f1	Øs2	Ød1	l1	t1	u1	o
PD/PM 83	100	250	180	215	5.0	M12	28	60	31.3	8	127
PD/PM 83	112	250	180	215	5.0	M12	28	60	31.3	8	127
PD/PM 82-83	132	300	230	265	5.0	M12	38	80	41.3	10	177
PD/PM 82-83	160	350	250	300	6.0	M16	42	110	45.3	12	266
PD/PM 82-83	180	350	250	300	6.0	M16	48	110	51.8	14	266
PD/PM 82-83	200	400	300	350	6.0	M16	55	110	59.3	16	229
PD/PM 82-83	225	450	350	400	6.0	M16	60	140	64.4	18	303
PD/PM 82	250	550	450	500	6.0	M16	65	140	69.4	18	304
PD/PM 82	280	550	450	500	6.0	M16	75	140	79.9	20	304

~ Kg		
IEC	PD/PM 82	PD/PM 83
100	-	422
112	-	422
132	431	436
160	458	462
180	458	462
200	473	477
225	489	493
250	547	-
280	547	-

PD 82
PD 83

W

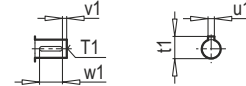
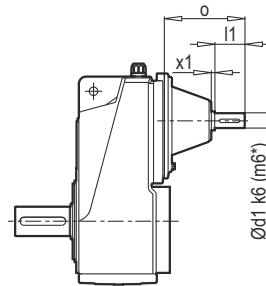
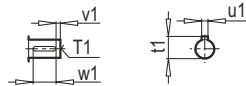
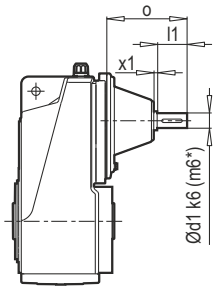

PM 82
PM 83

Tip / Type	Ød1	x1	l1	o	T1	t1	u1	v1	w1
PD/PM 82	65*	12	140	397	M20	69	18	15	110
PD/PM 83	42	8	110	288	M16	45	12	10	90

~ Kg	
PD/PM 82	PD/PM 83
510	435

PD 82
PD 83

PAM B5/B14

PM 82
PM 83

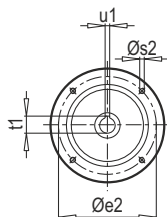
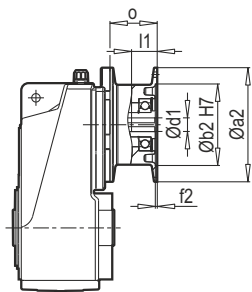

PAM 100...200

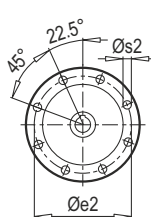

PAM 225...315

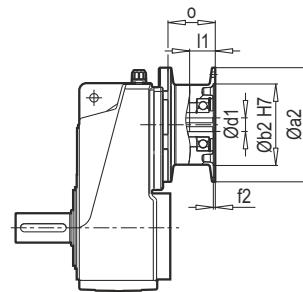

Tip / Type	PAM B5	Øa2	Øb2	Øe2	f2	Øs2	Ød1	l1	t1	u1	o
PD/PM 83	100	250	180	215	5.0	M12	28	60	31.3	8	75
PD/PM 83	112	250	180	215	5.0	M12	28	60	31.3	8	75
PD/PM 82-83	132	300	230	265	5.0	M12	38	80	41.3	10	110
PD/PM 82-83	160	350	250	300	6.0	M16	42	110	45.3	12	145
PD/PM 82-83	180	350	250	300	6.0	M16	48	110	51.8	14	145
PD/PM 82-83	200	400	300	350	6.0	M16	55	110	59.3	16	157
PD/PM 82-83	225	450	350	400	6.0	M16	60	140	64.4	18	183
PD/PM 82	250	550	450	500	6.0	M16	65	140	69.4	18	202
PD/PM 82	280	550	450	500	6.0	M16	75	140	79.9	20	202

~ Kg		
PAM B5	PD/PM 82	PD/PM 83
100	-	385
112	-	385
132	392	396
160	409	413
180	409	413
200	416	419
225	426	430
250	486	-
280	486	-

Tip / Type	PAM B14	Øa2	Øb2	Øe2	f2	Øs2	Ød1	l1	t1	u1	o
PD/PM 83	100	160	110	130	5.0	9	28	60	31.3	8	75
PD/PM 83	112	160	110	130	5.0	9	28	60	31.3	8	75
PD/PM 82-83	132	200	130	165	5.0	11	38	80	41.3	10	110

~ Kg		
PAM B14	PD/PM 82	PD/PM 83
100	-	384
112	-	384
132	387	391

PD 92

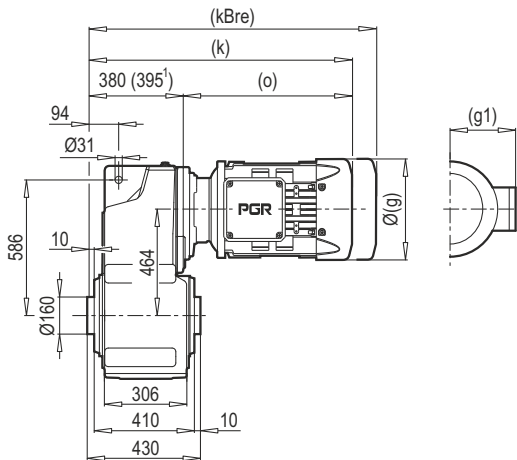

dH	Ø 120	(Ø 125)	(Ø 110)	(Ø 100)
uH	32	(32)	(28)	(28)
tH	127.4	(132.4)	(116.4)	(106.4)

PD 92 B5

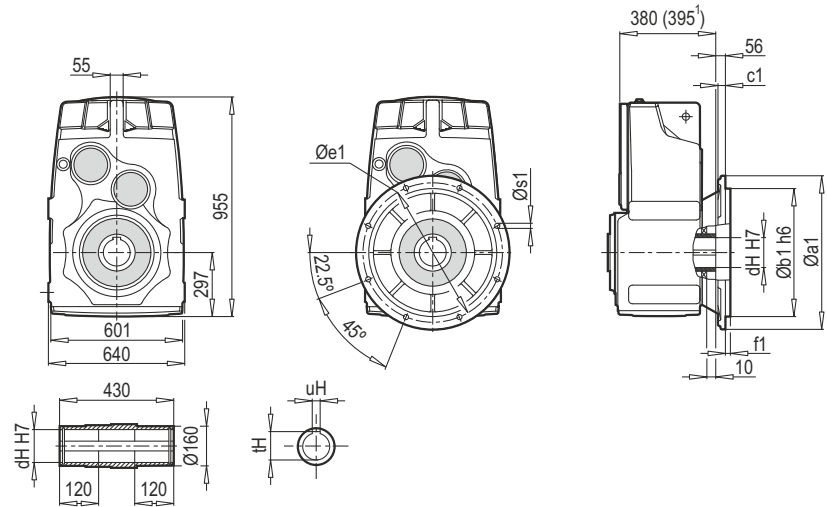

a1	b1	c1	e1	f1	s1
660	550	32	600	6	8x22

PM 92

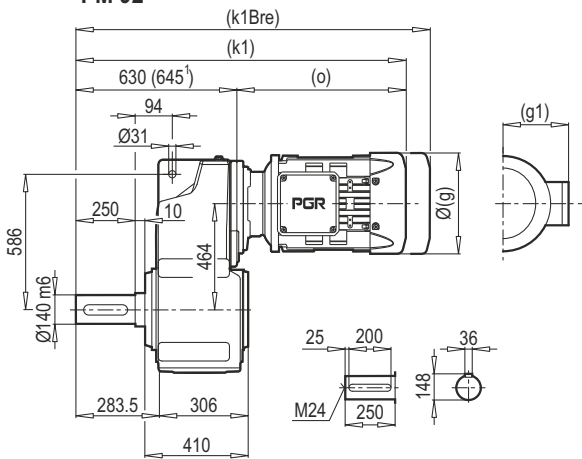

PM 92 B5

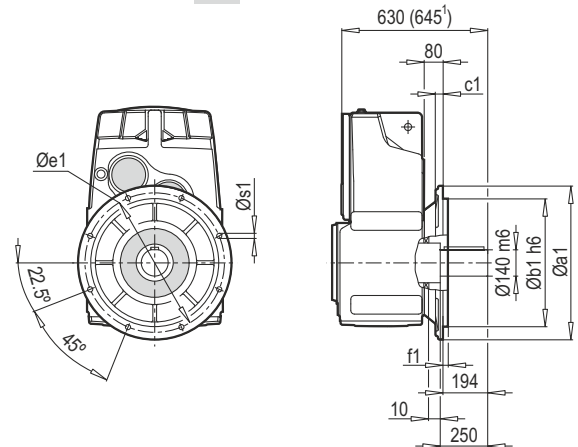

PD 92 KS

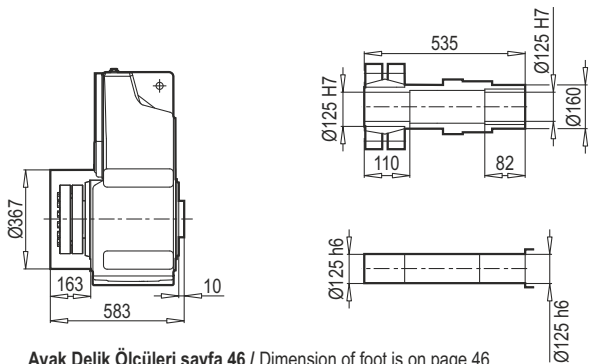

PD 92 DIN 5480

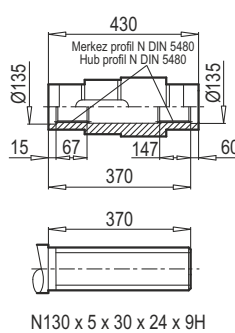

PD 92 Ç

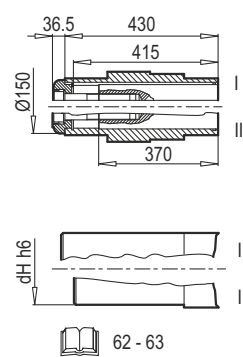

Ayak Delik Ölçüleri sayfa 46 / Dimension of foot is on page 46

	200 L	225 S/M	250 M ¹⁾	280 S ¹⁾	280 M ¹⁾	315 S ¹⁾	315 M ¹⁾
g	415	456	495	527	527	-	-
g1	260	260	392	367	367	-	-
k/k1	998/1248	1080/1330	1039/1289	1280/1530	1280/1530	-	-
kBre/k1Bre	1145/1395	1252/1502	1169/1419	-	-	-	-
o	618	700	644	885	885	-	-

Not : (... İşaretili olan ölçüler Motor markasına göre farklılık gösterir / Note : The dimensions which have (...) sign vary depending on the motor brand.

PD 93

PD 93 B5

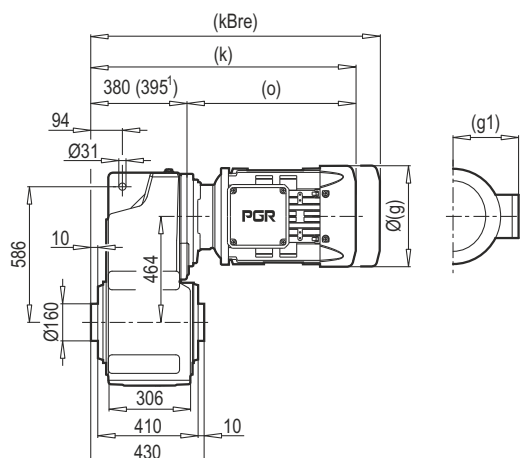

dH	Ø 120	Ø 125	Ø 110	Ø 100
uH	32	(32)	(28)	(28)
tH	127.4	(132.4)	(116.4)	(106.4)

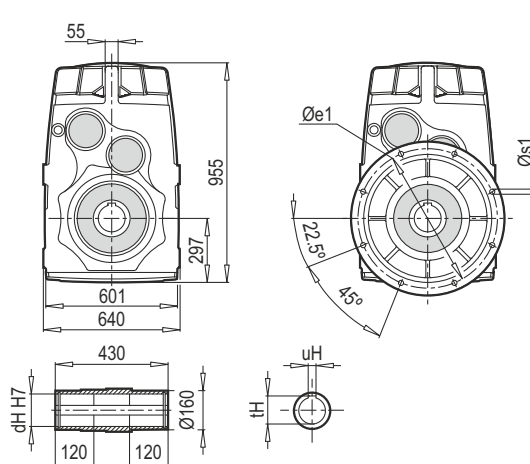

a1	b1	c1	e1	f1	s1
660	550	32	600	6	8x22

PM 93

PM 93 B5

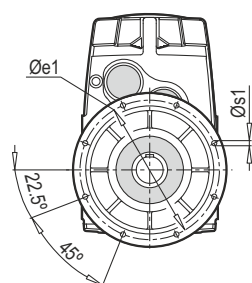
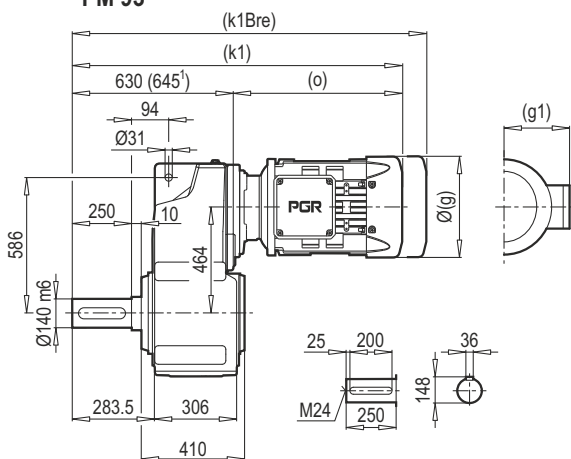

PD 93 KS

PD 93 DIN 5480

PD 93 Ç

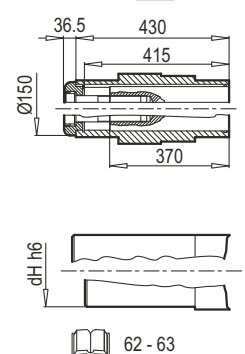
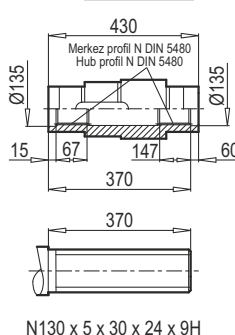
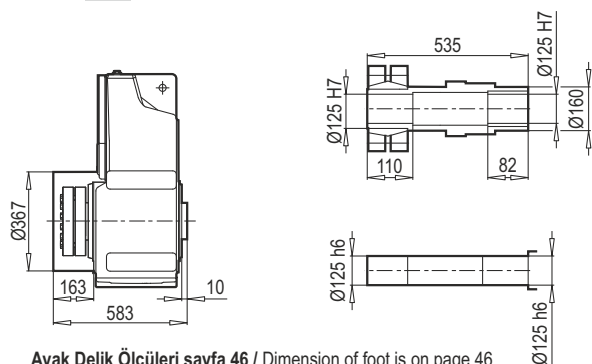

Ayak Delik Ölçüleri sayfa 46 / Dimension of foot is on page 46

	132 S	132 M	160 M/L	180 M/L	200 L	225 S/M	250 M ¹⁾	280 S ¹⁾
g	279	279	323	370	415	456	495	527
g1	182	182	200	248	260	260	392	367
k/k1	743/993	778/1028	844/1094	903/1153	998/1248	1080/1330	1039/1289	1280/1530
kBre/k1Bre	851/1101	919/1169	996/1246	1065/1315	1145/1395	1252/1502	1169/1419	-
o	363	398	464	523	618	700	644	885

Not : (...) İşaretli olan ölçüler Motor markasına göre farklılık gösterir / Note : The dimensions which have (...) sign vary depending on the motor brand.

PD/PM 92
PD/PM 93

PD 92
PD 93

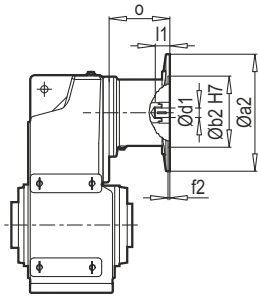

IEC

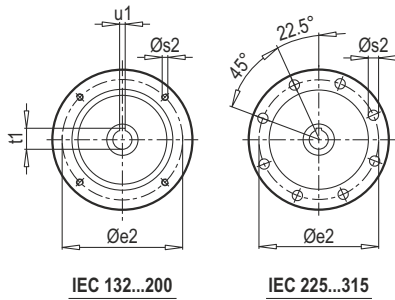

PM 92
PM 93

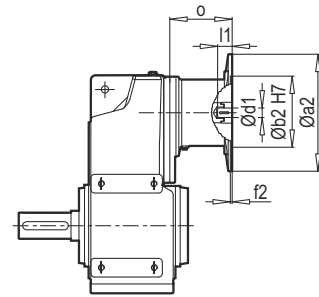

Tip / Type	IEC	Øa2	Øb2	Øe2	f2	Øs2	Ød1	l1	t1	u1	o
PD/PM 93	132	300	230	265	5.0	M12	38	80	41.3	10	177
PD/PM 93	160	350	250	300	6.0	M16	42	110	45.3	12	266
PD/PM 92-93	180	350	250	300	6.0	M16	48	110	51.8	14	266
PD/PM 92-93	200	400	300	350	6.0	M16	55	110	59.3	16	229
PD/PM 92-93	225	450	350	400	6.0	M16	60	140	64.4	18	303
PD/PM 92-93	250	550	450	500	6.0	M16	65	140	69.4	18	304
PD/PM 92-93	280	550	450	500	6.0	M16	75	140	79.9	20	304
PD/PM 92	315	660	550	600	7.0	M20	80	170	85.4	22	382

~ Kg		
IEC	PD/PM 92	PD/PM 93
132	-	756
160	-	782
180	777	782
200	792	797
225	808	813
250	866	871
280	866	871
315	951	-

PD 92
PD 93

W

PM 92
PM 93

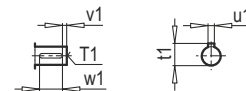
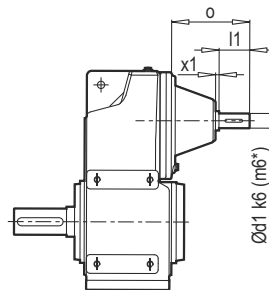
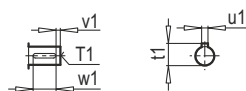
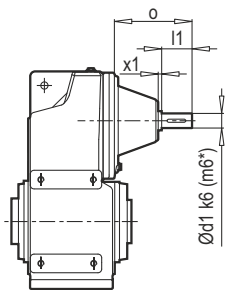

Tip / Type	Ød1	x1	l1	o	T1	t1	u1	v1	w1
PD/PM 92	65*	12	140	397	M20	69	18	15	110
PD/PM 93	42	8	110	288	M16	45	12	10	90

~ Kg	
PD/PM 92	PD/PM 93
829	755

PD 92
PD 93

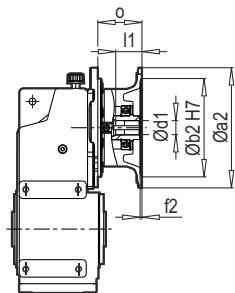

PAM B5/B14

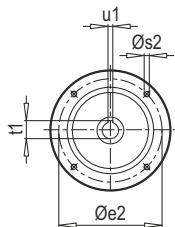

PAM 132...200

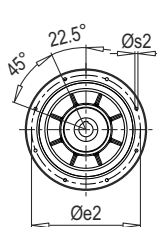

PAM 225...315

PM 92
PM 93

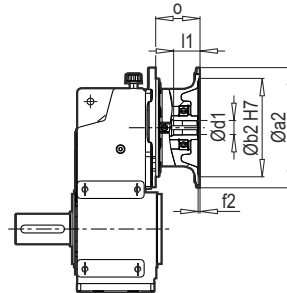

Tip / Type	PAM B5	Øa2	Øb2	Øe2	f2	Øs2	Ød1	l1	t1	u1	o
PD/PM 93	132	300	230	265	5.0	M12	38	80	41.3	10	110
PD/PM 93	160	350	250	300	6.0	M16	42	110	45.3	12	145
PD/PM 92-93	180	350	250	300	6.0	M16	48	110	51.8	14	145
PD/PM 92-93	200	400	300	350	6.0	M16	55	110	59.3	16	157
PD/PM 92-93	225	450	350	400	6.0	M16	60	140	64.4	18	183
PD/PM 92-93	250	550	450	500	6.0	M16	65	140	69.4	18	202
PD/PM 92-93	280	550	450	500	6.0	M16	75	140	79.9	20	202

~ Kg		
PAM B5	PD/PM 92	PD/PM 93
132	-	698
160	-	715
180	710	715
200	717	722
225	727	722
250	787	792
280	787	792

Tip / Type	PAM B14	Øa2	Øb2	Øe2	f2	Øs2	Ød1	l1	t1	u1	o
PD/PM 93	132	200	130	165	5.0	11	38	80	41.3	10	110

~ Kg		
PAM B14	PD/PM 92	PD/PM 93
132	-	693

PD 102

PD 102 B5

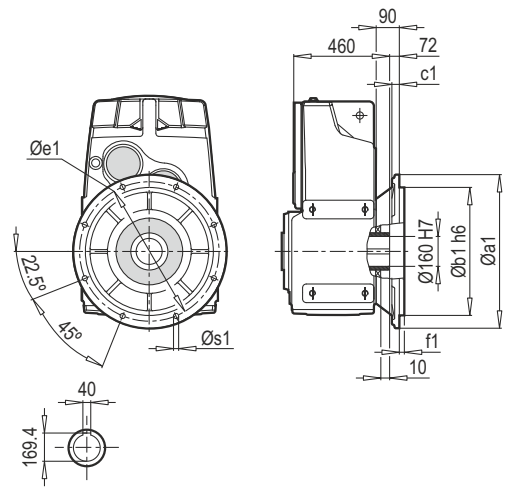
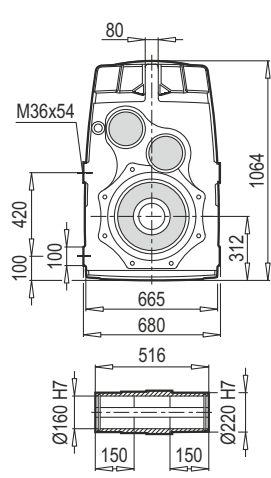
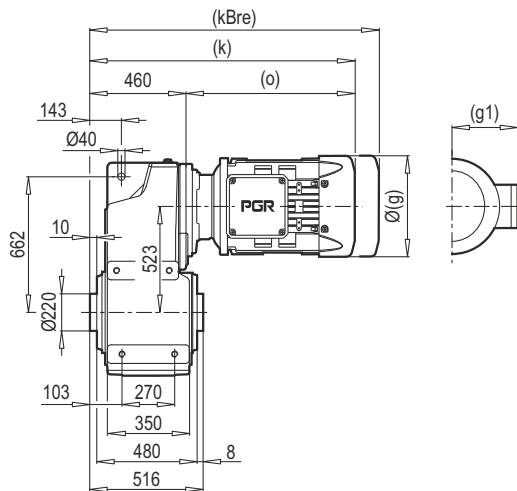

a1	b1	c1	e1	f1	s1
660	550	35	600	8	8x26

PM 102

PM 102 B5

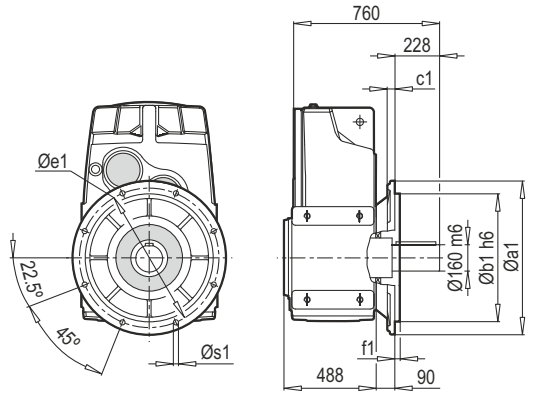
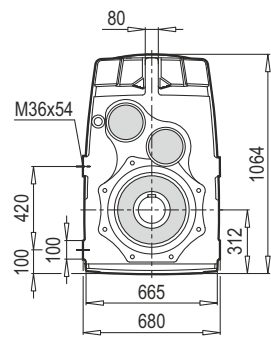
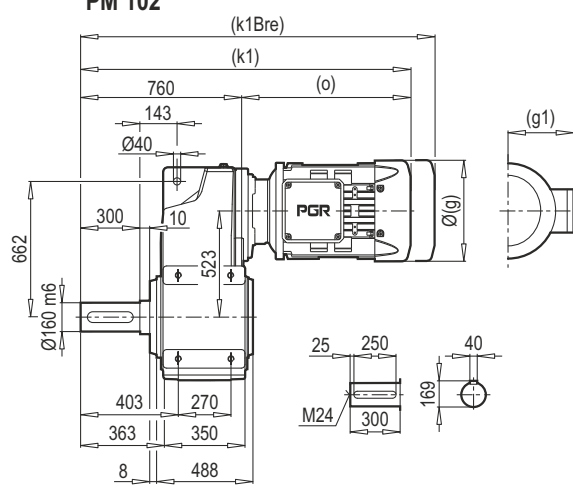

PD 102 KS

B14

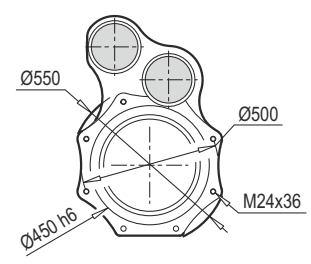
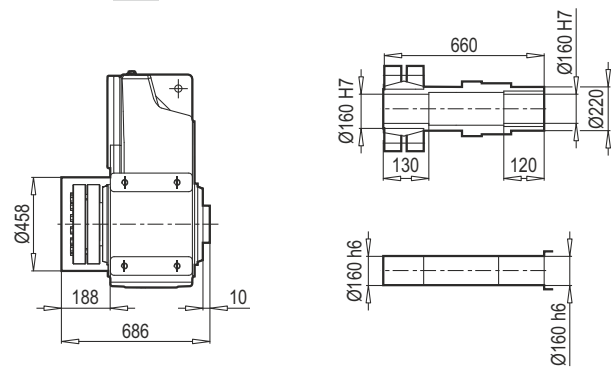

	280 S	280 M	315 S	315 M	315 L			
g	527	527	-	-	-			
g1	367	367	-	-	-			
k/k1	1345/1645	1345/1645	-	-	-			
kBre/k1Bre	-	-	-	-	-			
o	885	885	-	-	-			

Not : (...) İşaretli olan ölçüler Motor markasına göre farklılık gösterir / Note : The dimensions which have (...) sign vary depending on the motor brand.

PD 103

PD 103 B5

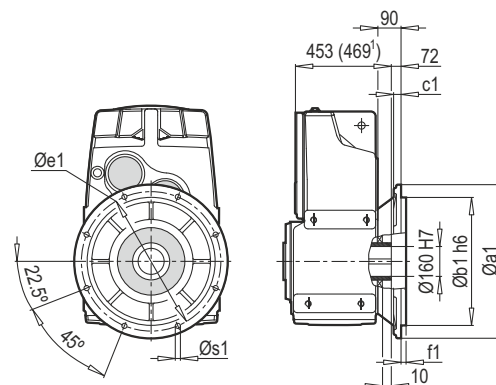
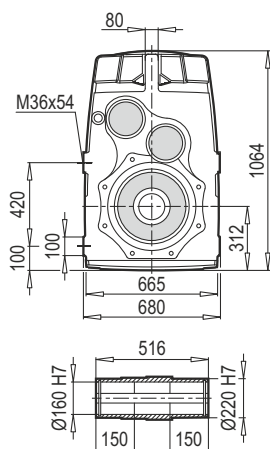
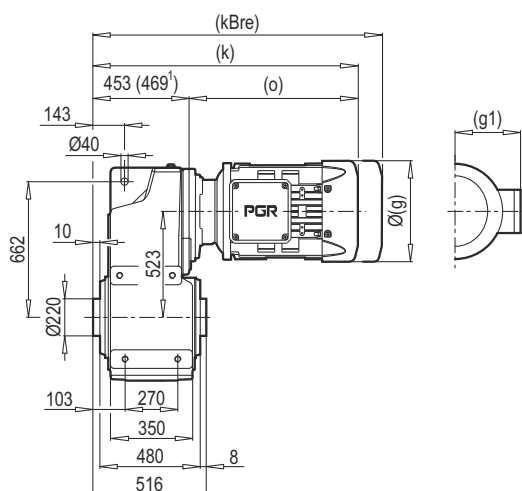

a1	b1	c1	e1	f1	s1
660	550	35	600	8	8x26

PM 103

PM 103 B5

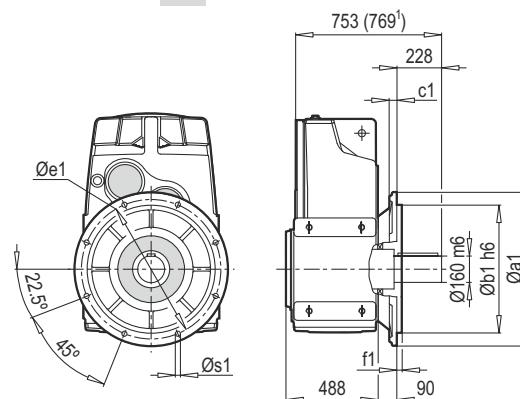
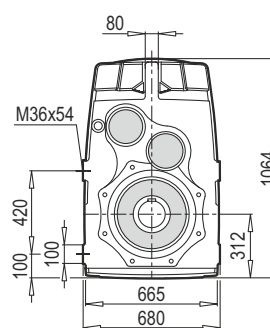
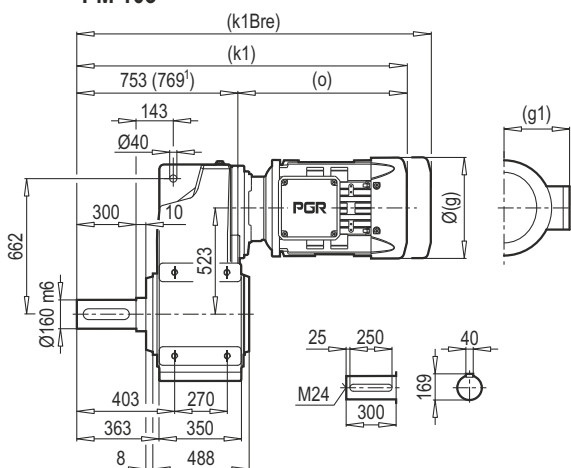

PD 103 KS

B14

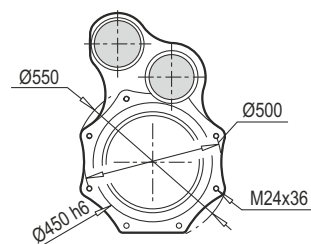
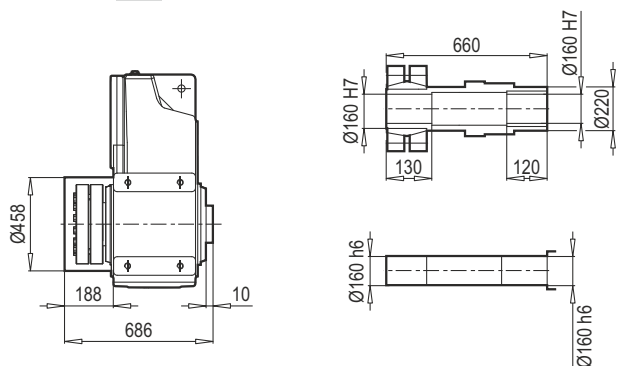

	132 M	160 M/L	180 M/L	200 L	225 S/M	250 M ¹⁾	280 S ¹⁾	280 M ¹⁾	315 S ¹⁾	315 M ¹⁾
g	279	323	370	415	456	495	527	527	-	-
g1	182	200	248	260	260	392	367	367	-	-
k/k1	851/1151	917/1217	976/1276	1071/1371	1153/1453	1113/1413	1354/1654	1354/1654	-	-
kBre/k1Bre	992/1292	1069/1369	1138/1438	1218/1518	1325/1625	1243/1543	-	-	-	-
o	398	464	523	618	700	644	885	885	-	-

Not : (...) İşaretli olan ölçüler Motor markasına göre farklılık gösterir / Note : The dimensions which have (...) sign vary depending on the motor brand.

PD/PM 102
PD/PM 103

PD 102
PD 103

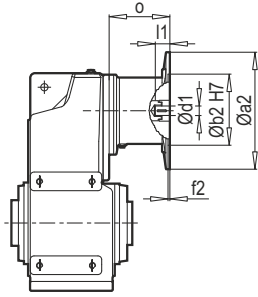

IEC

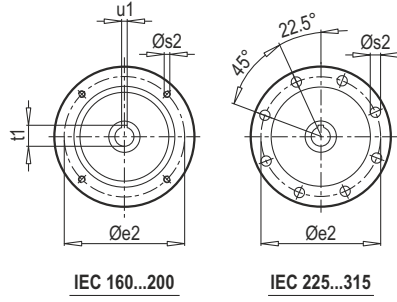

PM 102
PM 103

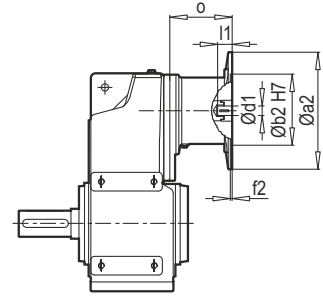

Tip / Type	IEC	Øa2	Øb2	Øe2	f2	Øs2	Ød1	l1	t1	u1	o
PD/PM 103	160	350	250	300	6.0	M16	42	110	45.3	12	266
PD/PM 103	180	350	250	300	6.0	M16	48	110	51.8	14	266
PD/PM 103	200	400	300	350	6.0	M16	55	110	59.3	16	229
PD/PM 103	225	450	350	400	6.0	M16	60	140	64.4	18	303
PD/PM 102-103	250	550	450	500	6.0	M16	65	140	69.4	18	304
PD/PM 102-103	280	550	450	500	6.0	M16	75	140	79.9	20	304
PD/PM 102-103	315	660	550	600	7.0	M20	80	170	85.4	22	382

~ Kg		
IEC	PD/PM 102	PD/PM 103
132	-	756
160	-	782
180	777	782
200	792	797
225	808	813
250	866	871
280	866	871

PD 102
PD 103

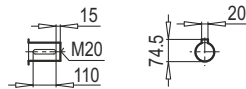
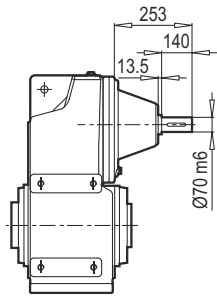

W

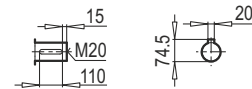
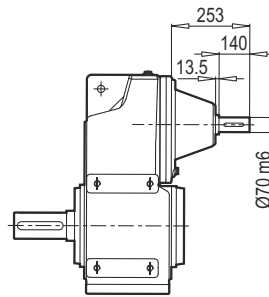

PM 102
PM 103

~ Kg	
PD/PM 102	1358
PD/PM 103	1384

PD 102
PD 103

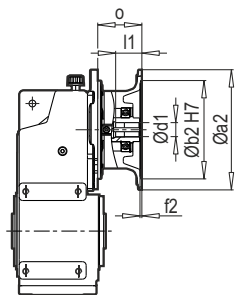

PAM B5

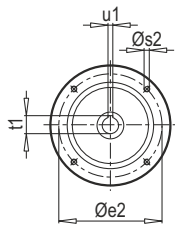

PAM 160...200

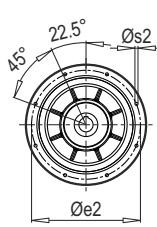

PAM 225...315

PM 102
PM 103

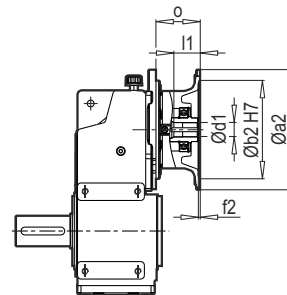

Tip / Type	PAM B5	Øa2	Øb2	Øe2	f2	Øs2	Ød1	l1	t1	u1	o
PD/PM 103	160	350	250	300	6.0	M16	42	110	45.3	12	145
PD/PM 103	180	350	250	300	6.0	M16	48	110	51.8	14	145
PD/PM 103	200	400	300	350	6.0	M16	55	110	59.3	16	157
PD/PM 103	225	450	350	400	6.0	M16	60	140	64.4	18	183
PD/PM 102-103	250	550	450	500	6.0	M16	65	140	69.4	18	202
PD/PM 102-103	280	550	450	500	6.0	M16	75	140	79.9	20	202

~ Kg		
PAM B5	PD/PM 102	PD/PM 103
160	-	1279
180	-	1279
200	-	1286
225	-	1296
250	1331	1356
280	1331	1356

PD 112

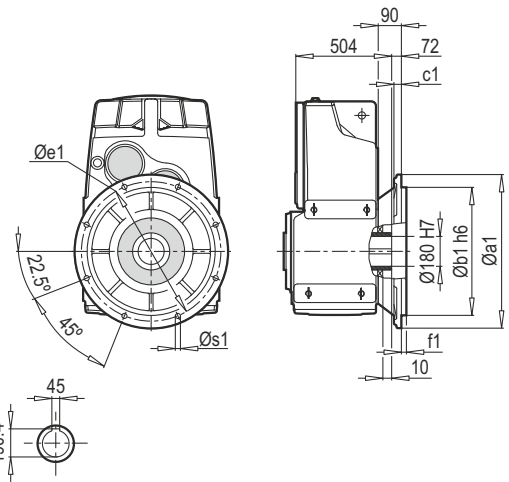
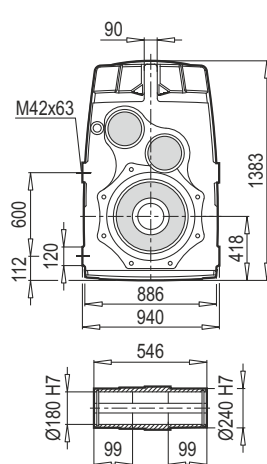
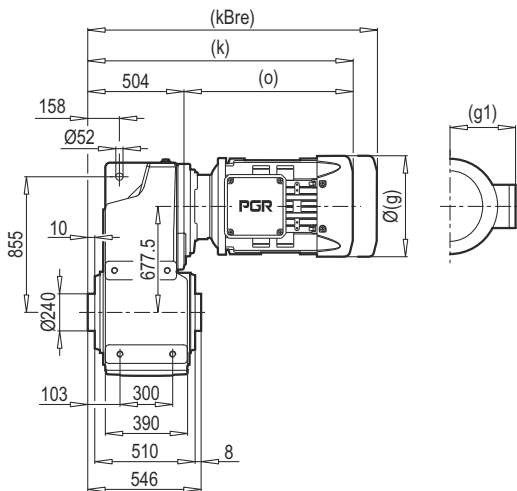

a1	b1	c1	e1	f1	s1
660	550	35	600	8	8x26

PM 112

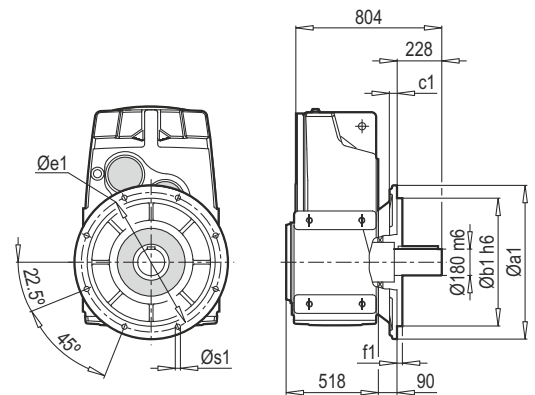
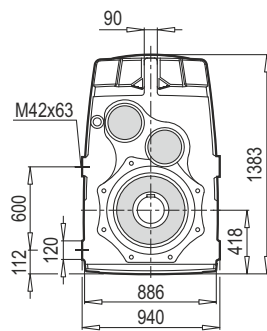
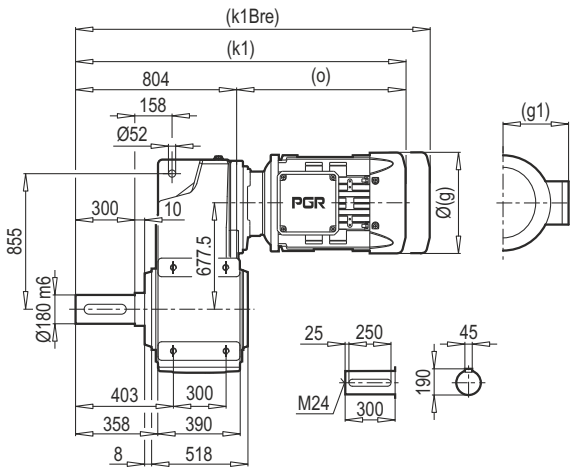

PM 112 B5

PD 112 KS

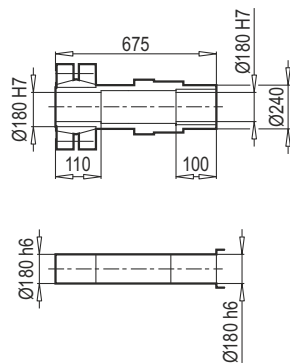
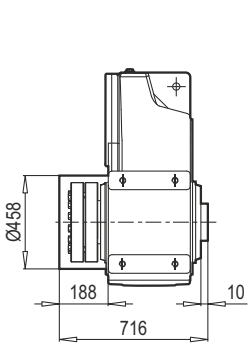

B14

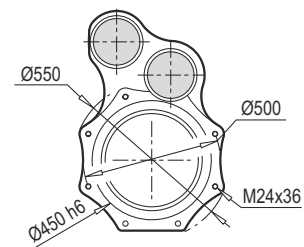

	280 S	280 M	315 S	315 M	315 L		
g	527	527	-	-	-		
g1	367	367	-	-	-		
k/k1	1389/1689	1389/1689	-	-	-		
kBre/k1Bre	-	-	-	-	-		
o	885	885	-	-	-		

Not : (...) İşaretli olan ölçüler Motor markasına göre farklılık gösterir / Note : The dimensions which have (...) sign vary depending on the motor brand.

PD 113

PD 113 B5

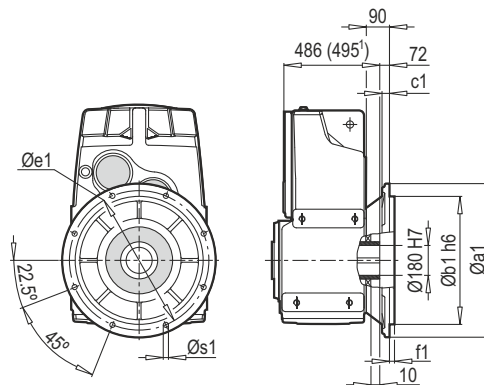
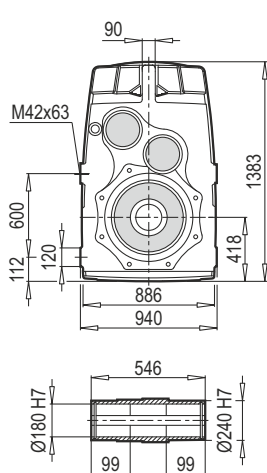
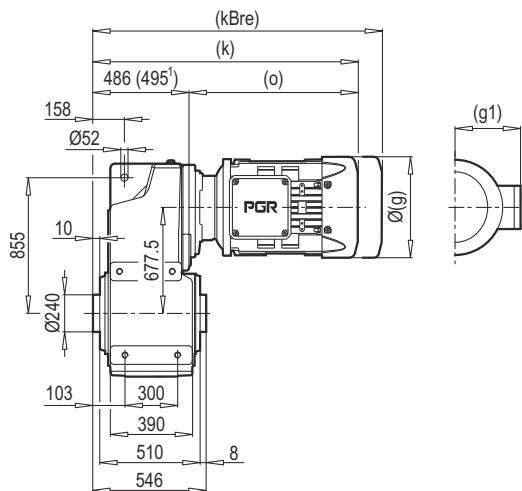

a1	b1	c1	e1	f1	s1
660	550	35	600	8	8x26

PM 113

PM 113 B5

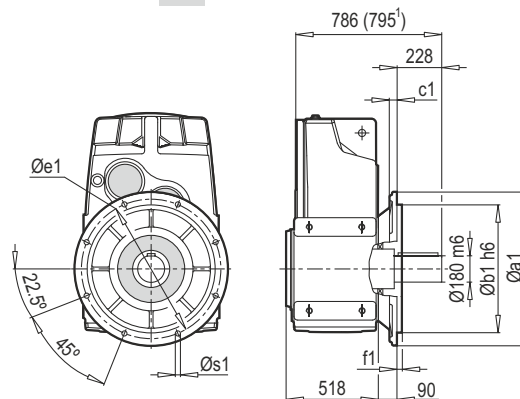
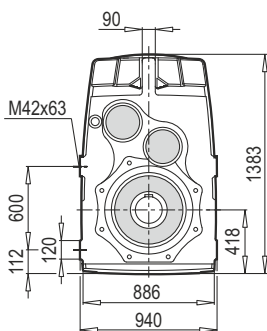
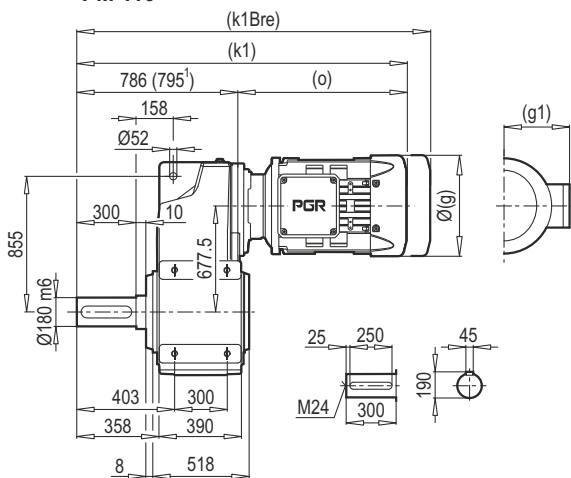

PD 113 KS

B14

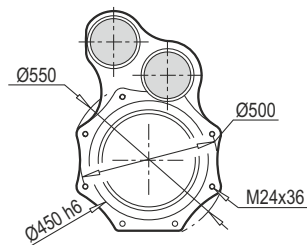
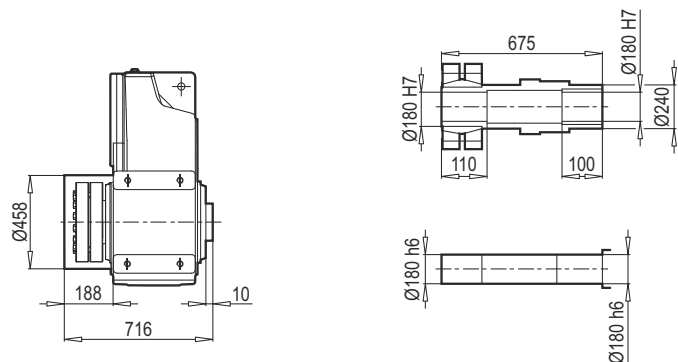

	160 M/L	180 M/L	200 L	225 S/M	250 M	280 S	280 M ¹⁾	315 S ¹⁾	315 M ¹⁾	315 L ¹⁾
g	323	370	415	456	495	527	527	-	-	-
g1	200	248	260	260	392	367	367	-	-	-
k/k1	950/1250	1009/1309	1104/1404	1186/1486	1130/1430	1380/1680	1380/1680	-	-	-
kBre/k1Bre	1102/1402	1171/1471	1251/1551	1358/1658	1260/1560	-	-	-	-	-
o	464	523	618	700	644	885	885	-	-	-

Not : (...) işaretli olan ölçüler Motor markasına göre farklılık gösterir / Note : The dimensions which have (...) sign vary depending on the motor brand.

PD/PM 112
PD/PM 113

PD 112
PD 113

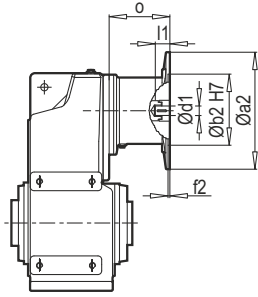

IEC

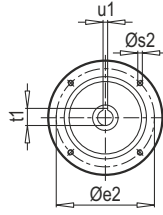

IEC 160...200

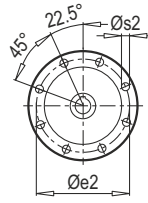

IEC 225...315

PM 112
PM 113

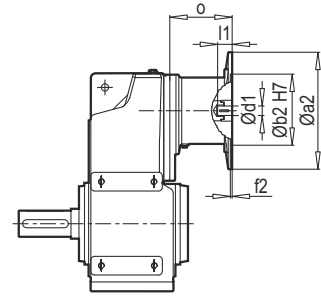

Tip / Type	IEC	Øa2	Øb2	Øe2	f2	Øs2	Ød1	l1	t1	u1	o
PD/PM 113	160	350	250	300	6.0	M16	42	110	45.3	12	266
PD/PM 113	180	350	250	300	6.0	M16	48	110	51.8	14	266
PD/PM 113	200	400	300	350	6.0	M16	55	110	59.3	16	229
PD/PM 113	225	450	350	400	6.0	M16	60	140	64.4	18	303
PD/PM 112-113	250	550	450	500	6.0	M16	65	140	69.4	18	304
PD/PM 112-113	280	550	450	500	6.0	M16	75	140	79.9	20	304
PD/PM 112-113	315	660	550	600	7.0	M20	80	170	85.4	22	382

~ Kg		
IEC	PD/PM 112	PD/PM 113
160	-	2268
180	-	2268
200	-	2283
225	-	2299
250	2276	2357
280	2276	2357
315	2361	2442

PD 112
PD 113

W

PM 112
PM 113

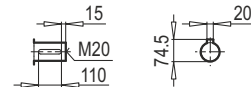
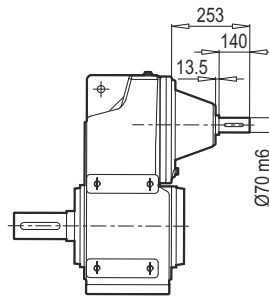
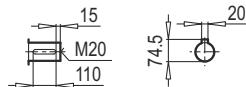
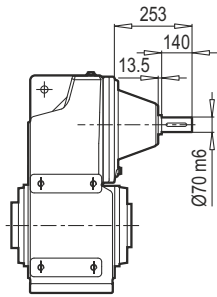

~ Kg	
PD/PM 112	2191
PD/PM 113	2273

PD 112
PD 113

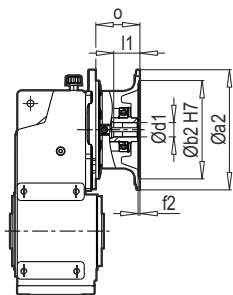

PAM B5

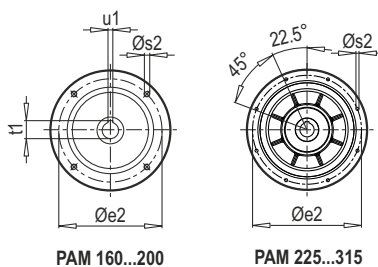

PAM 160...200

PAM 225...315

PM 112
PM 113

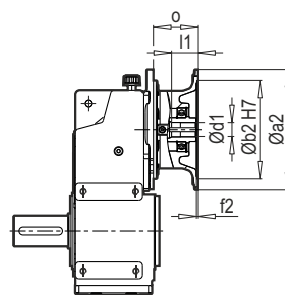

Tip / Type	PAM B5	Øa2	Øb2	Øe2	f2	Øs2	Ød1	l1	t1	u1	o
PD/PM 113	160	350	250	300	6.0	M16	42	110	45.3	12	145
PD/PM 113	180	350	250	300	6.0	M16	48	110	51.8	14	145
PD/PM 113	200	400	300	350	6.0	M16	55	110	59.3	16	157
PD/PM 113	225	450	350	400	6.0	M16	60	140	64.4	18	183
PD/PM 112-113	250	550	450	500	6.0	M16	65	140	69.4	18	202
PD/PM 112-113	280	550	450	500	6.0	M16	75	140	79.9	20	202

~ Kg		
PAM B5	PD/PM 112	PD/PM 113
160	-	2117
180	-	2117
200	-	2124
225	-	2134
250	2117	2194
280	2117	2194

PD 123

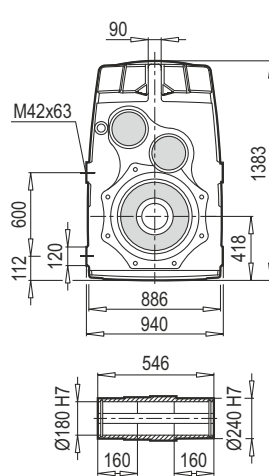
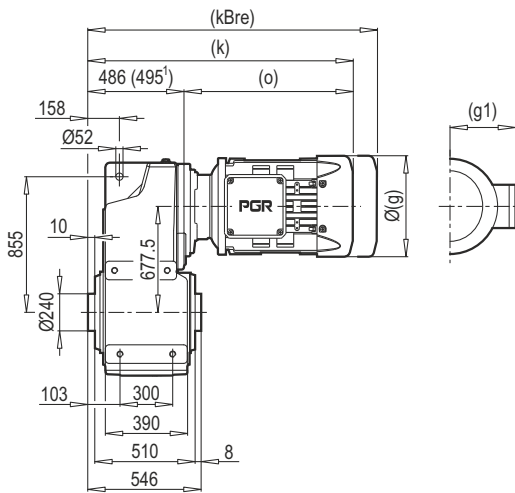

PD 123 B5

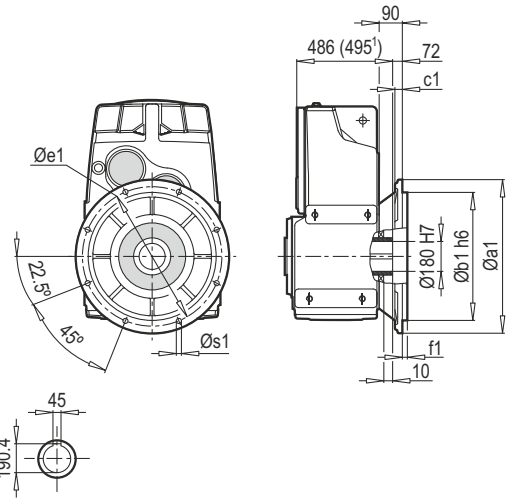

a1	b1	c1	e1	f1	s1
660	550	35	600	8	8x26

PM 123

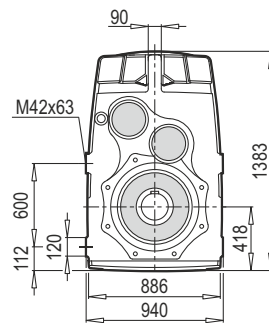
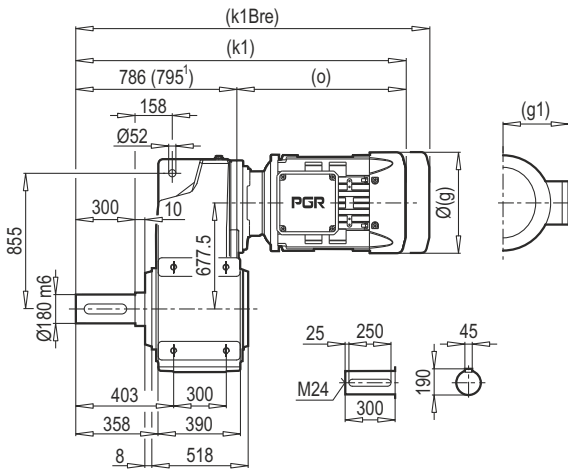

PM 123 B5

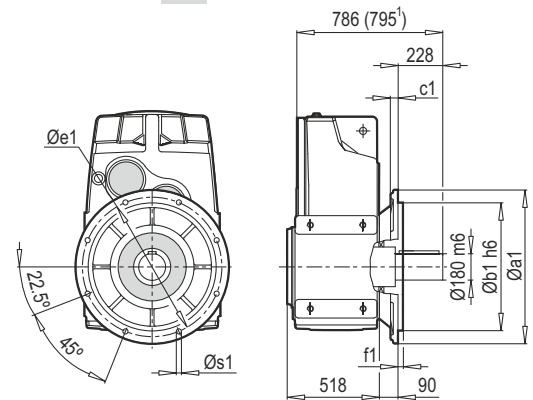

PD 123 KS

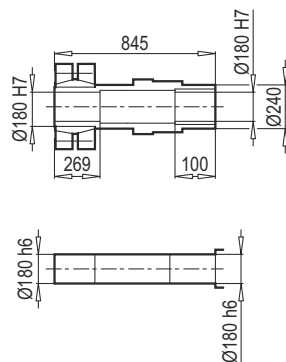
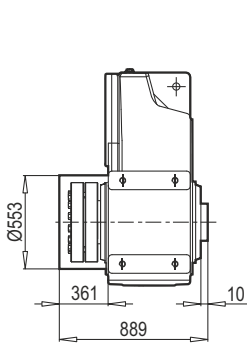

B14

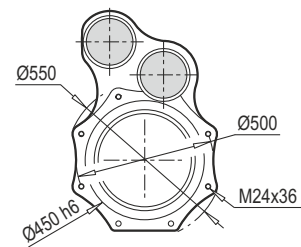

	200 L	225 S/M	250 M	280 S	280 M ¹⁾	315 S ¹⁾	315 M ¹⁾	315 L ¹⁾
g	415	456	495	527	527	-	-	-
g1	260	260	392	367	367	-	-	-
k/k1	1104/1404	1186/1486	1130/1430	1380/1680	1380/1680	-	-	-
kBre/k1Bre	1251/1551	1358/1658	1260/1560	-	-	-	-	-
o	618	700	644	885	885	-	-	-

Not : (...) İřaretli olan ölçüler Motor markasına göre farklılık gösterir / Note : The dimensions which have (...) sign vary depending on the motor brand.

PD 123

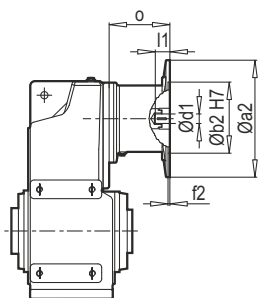

IEC

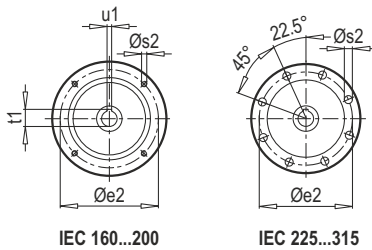

IEC 160...200

IEC 225...315

PM 123

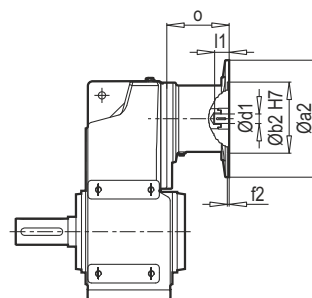

Tip / Type	IEC	Øa2	Øb2	Øe2	f2	Øs2	Ød1	l1	t1	u1	o
PD/PM 123	160	350	250	300	6.0	M16	42	110	45.3	12	266
	180	350	250	300	6.0	M16	48	110	51.8	14	266
	200	400	300	350	6.0	M16	55	110	59.3	16	229
	225	450	350	400	6.0	M16	60	140	64.4	18	303
	250	550	450	500	6.0	M16	65	140	69.4	18	304
	280	550	450	500	6.0	M16	75	140	79.9	20	304
	315	660	550	600	7.0	M20	80	170	85.4	22	382

~ Kg	
IEC	PD/PM 123
160	2268
180	2268
200	2283
225	2299
250	2357
280	2357
315	2442

PD 123

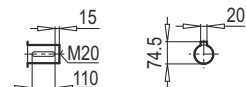
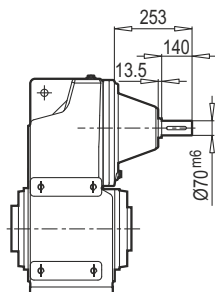

W

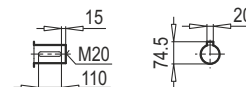
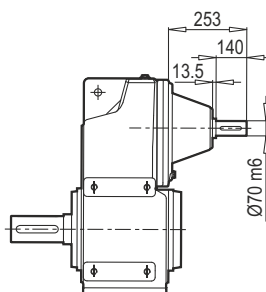

PM 123

~ Kg	
PD/PM 123	2273

PD 123

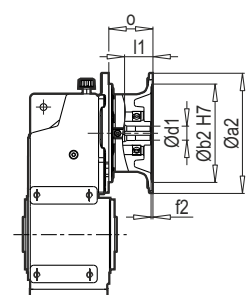

PAM B5/B14

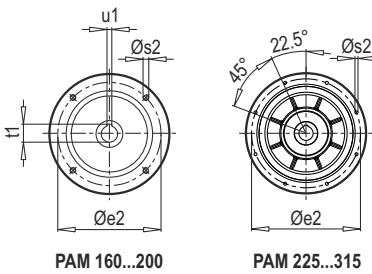

PAM 160...200

PAM 225...315

PM 123

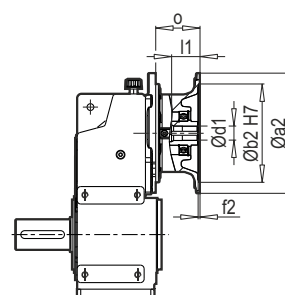

Tip / Type	PAM B5	Øa2	Øb2	Øe2	f2	Øs2	Ød1	l1	t1	u1	o
PD/PM 123	160	350	250	300	6.0	M16	42	110	45.3	12	145
	180	350	250	300	6.0	M16	48	110	51.8	14	145
	200	400	300	350	6.0	M16	55	110	59.3	16	157
	225	450	350	400	6.0	M16	60	140	64.4	18	183
	250	550	450	500	6.0	M16	65	140	69.4	18	202
	280	550	450	500	6.0	M16	75	140	79.9	20	202

~ Kg	
PAM B5	PD/PM 123
160	2222
180	2222
200	2229
225	2239
250	2299
280	2299

DÖRT KADEME
QUADRUPLE REDUCTION

PD 12/02 PD 32/12
PD 22/02 PD 42/12
PD 52/12

PM 12/02 PM 32/12
PM 22/02 PM 42/12
PM 52/12

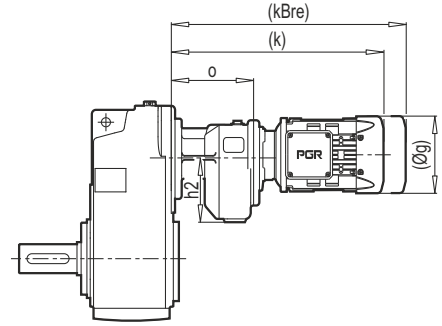
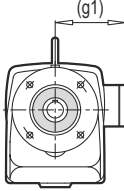
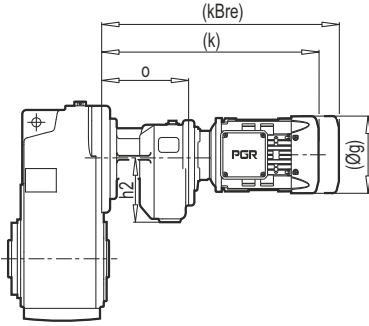

Tip / Type	Motor	g	g1	h2	o	k	kBre
PD/PM 12/02	63 M	124	111	91	143	341	393
PD/PM 22/02	63 M	124	111	91	159	373	425
	71 M	140	119			415	475
	80 M	159	127			442	504
PD/PM 32/12	63 M	124	111	108	172	386	438
	71 M	140	119			428	488
	90 S	193	151			478	551
	90 L	193	151			498	571
PD/PM 42/12	63 M	124	111	108	176	386	438
	71 M	140	119			428	488
	80 M*	159	127			455	517
PD/PM 52/12	100 L	217	160			526	607

Not : (...) İşaretli olan ölçüler Motor markasına göre farklılık gösterir.
Note : The dimensions which have (...) sign vary depending on the motor brand.

(*) İşaretli olan motor PD/PM 52/12'ye bağlanmamaktadır.
(*) The motor which has been marked is not applicable to PD/PM 52/12.

PD 12/02 PD 32/12
PD 22/02 PD 42/12
PD 52/12

IEC

PM 12/02 PM 32/12
PM 22/02 PM 42/12
PM 52/12

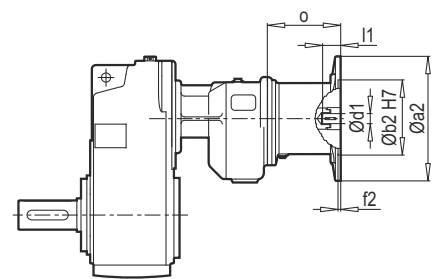
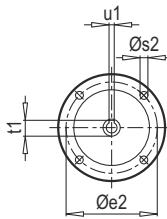
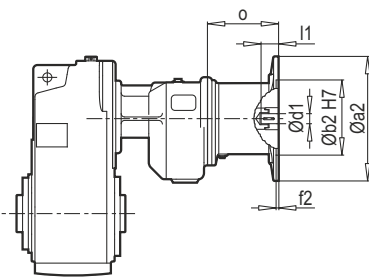

Tip / Type	IEC	Øa2	Øb2	Øe2	f2	Øs2	Ød1	l1	t1	u1	o
PD/PM 12/02 - 22/02 - 32/12 - 42/12 - 52/12	63	140	95	115	3.5	M8	11	23	12.8	4	85
PD/PM 12/02 - 22/02 - 32/12 - 42/12 - 52/12	71	160	110	130	4.0	M8	14	30	16.3	5	89
PD/PM 12/02 - 22/02 - 32/12 - 42/12 - 52/12	80	200	130	165	4.0	M10	19	40	21.8	6	105
PD/PM 12/02 - 22/02 - 32/12 - 42/12 - 52/12	90	200	130	165	4.0	M10	24	50	27.3	8	105
PD/PM 32/12 - 42/12 - 52/12	100	250	180	215	5.0	M12	28	60	31.3	8	130
PD/PM 32/12 - 42/12 - 52/12	112	250	180	215	5.0	M12	28	60	31.3	8	130

~ Kg					
IEC	PD/PM 12/02	PD/PM 22/02	PD/PM 32/12	PD/PM 42/12	PD/PM 52/12
63	28	40	57	73	111
71	29	41	58	74	112
80	32	44	61	77	116
90	32	44	61	77	116
100	-	-	69	84	123
112	-	-	69	84	123

PD 12/02 PD 32/12
PD 22/02 PD 42/12
PD 52/12

W

PM 12/02 PM 32/12
PM 22/02 PM 42/12
PM 52/12

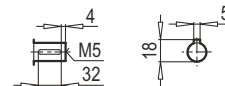
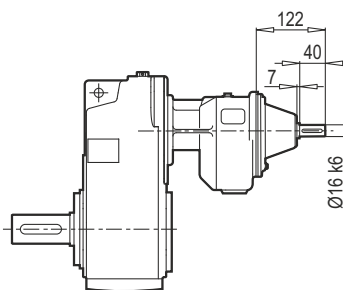
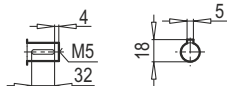
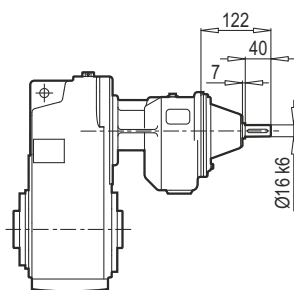

W ~ Kg	
PD/PM 12/02	27
PD/PM 22/02	38
PD/PM 32/12	56
PD/PM 43/12	72
PD/PM 53/12	110

PD 12/02 PD 32/12
PD 22/02 PD 42/12
PD 52/12

PAM B5/B14

PM 12/02 PM 32/12
PM 22/02 PM 42/12
PM 52/12

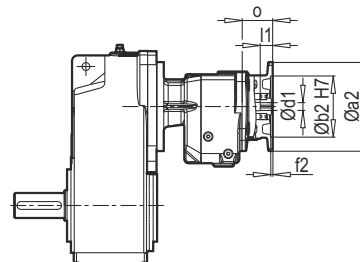
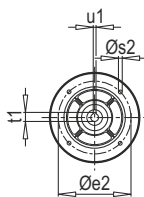
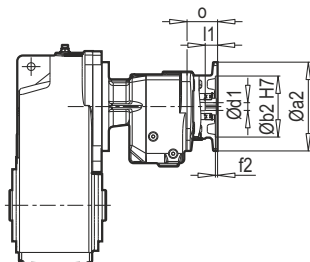

Tip / Type	PAM B5	Øa2	Øb2	Øe2	f2	Øs2	Ød1	l1	t1	u1	o
PD/PM 12/02 - 22/02 - 32/12 - 42/12 - 52/12	63	140	95	115	3.5	M8	11	23	12.8	4	85
PD/PM 12/02 - 22/02 - 32/12 - 42/12 - 52/12	71	160	110	130	4.0	M8	14	30	16.3	5	55
PD/PM 12/02 - 22/02 - 32/12 - 42/12 - 52/12	80	200	130	165	4.0	M10	19	40	21.8	6	74
PD/PM 12/02 - 22/02 - 32/12 - 42/12 - 52/12	90	200	130	165	4.0	M10	24	50	27.3	8	74
PD/PM 32/12 - 42/12 - 52/12	100	250	180	215	5.0	M12	28	60	31.3	8	131.5
PD/PM 32/12 - 42/12 - 52/12	112	250	180	215	5.0	M12	28	60	31.3	8	131.5

~ Kg					
PAM B5	PD/PM 12/02	PD/PM 22/02	PD/PM 32/12	PD/PM 42/12	PD/PM 52/12
63	26	37	54	69	105
71	26	37	54	69	105
80	27	38	55	70	106
90	27	38	55	70	106
100	-	-	62	77	113
112	-	-	62	77	113

Tip / Type	PAM B14	Øa2	Øb2	Øe2	f2	Øs2	Ød1	l1	t1	u1	o
PD/PM 12/02 - 22/02 - 32/12 - 42/12 - 52/12	63	90	60	75	3.5	6	11	23	12.8	4	60
PD/PM 12/02 - 22/02 - 32/12 - 42/12 - 52/12	71	105	70	85	4.0	7	14	30	16.3	5	55
PD/PM 12/02 - 22/02 - 32/12 - 42/12 - 52/12	80	120	80	100	4.0	7	19	40	21.8	6	74
PD/PM 12/02 - 22/02 - 32/12 - 42/12 - 52/12	90	140	95	115	4.0	9	24	50	27.3	8	74
PD/PM 32/12 - 42/12 - 52/12	100	160	110	130	5.0	9	28	60	31.3	8	75
PD/PM 32/12 - 42/12 - 52/12	112	160	110	130	5.0	9	28	60	31.3	8	75

~ Kg					
PAM B14	PD/PM 12/02	PD/PM 22/02	PD/PM 32/12	PD/PM 42/12	PD/PM 52/12
63	25	36	53	68	104
71	25	36	53	68	104
80	26	37	54	69	105
90	26	37	54	69	105
100	-	-	55	70	106
112	-	-	55	70	106

PD 63/22 PD 73/32
PD 73/22 PD 83/32

PM 63/22 PM 73/32
PM 73/22 PM 83/32

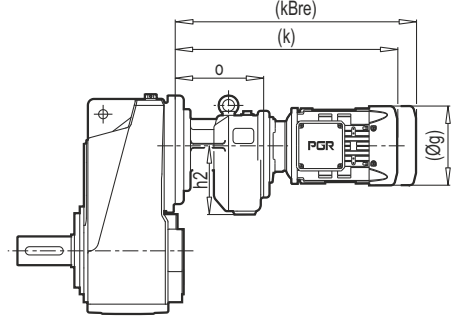
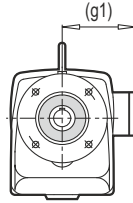
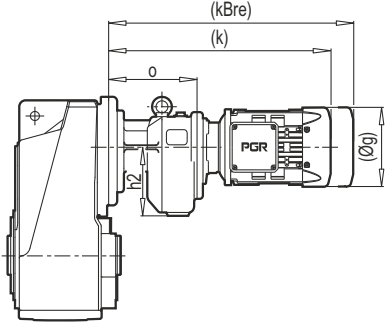

Tip / Type	Motor	g	g1	h2	o	k	kBre
PD/PM 63/22	71 M	140	119	127	180	416	476
	80 M	159	127			442	504
	90 S*	193	151			465	538
PD/PM 73/22	90 L	193	151	159	220	485	558
	100 L	217	160			513	594
	90 L	193	151			525	598
PD/PM 83/32	80 M	159	127	159	220	482	544
	90 S	193	151			505	578
	90 L	193	151			525	598
	100 L	217	160			553	634
	112 M	232	168			598	678
	90 L	193	151			525	598

Not : (...) İşaretli olan ölçüler Motor markasına göre farklılık gösterir.
Note : The dimensions which have (...) sign vary depending on the motor brand.

(*) İşaretli olan motor PD/PM 63/22'ye bağlanmamaktadır.
(*) The motor which has been marked is not applicable to PD/PM 63/22.

PD 63/22 PD 63/32
PD 73/22 PD 73/32
PD 83/32

IEC

PM 63/22 PM 63/32
PM 73/22 PM 73/32
PM 83/32

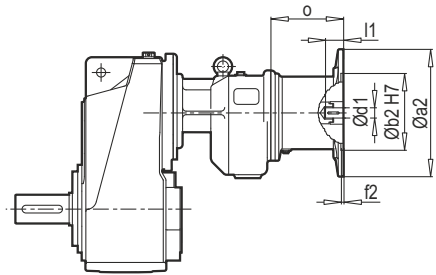
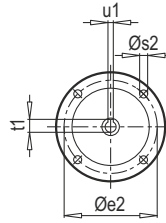
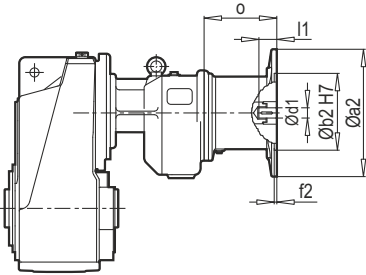

Tip / Type	IEC	Øa2	Øb2	Øe2	f2	Øs2	Ød1	l1	t1	u1	o
PD/PM 63/22 - 73/22 - 83/32	71	160	110	130	4.0	M8	14	30	16.3	5	88
PD/PM 63/22 - 73/22 - 83/32	80	200	130	165	4.0	M10	19	40	21.8	6	107
PD/PM 63/22 - 73/22 - 63/32 - 73/32 - 83/32	90	200	130	165	4.0	M10	24	50	27.3	8	107
PD/PM 63/22 - 73/22 - 63/32 - 73/32 - 83/32	100	250	180	215	5.0	M12	28	60	31.3	8	124
PD/PM 63/22 - 73/22 - 63/32 - 73/32 - 83/32	112	250	180	215	5.0	M12	28	60	31.3	8	124
PD/PM 63/32 - 73/32 - 83/32 -	132	300	230	265	5.0	M12	38	80	41.3	10	156

~ Kg					
IEC	PD/PM 63/22	PD/PM 73/22	PD/PM 63/32	PD/PM 73/32	PD/PM 83/32
71	209	286	-	-	432
80	213	290	-	-	437
90	213	290	225	301	437
100	217	294	229	306	441
112	217	294	229	306	441
132	-	-	238	315	451

PD 63/22 PD 63/32
PD 73/22 PD 73/32
PD 83/32

W

PM 63/22 PM 63/32
PM 73/22 PM 73/32
PM 83/32

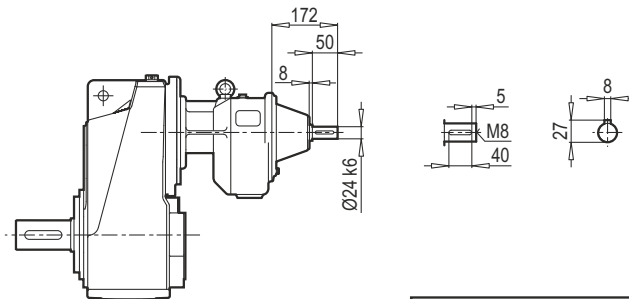
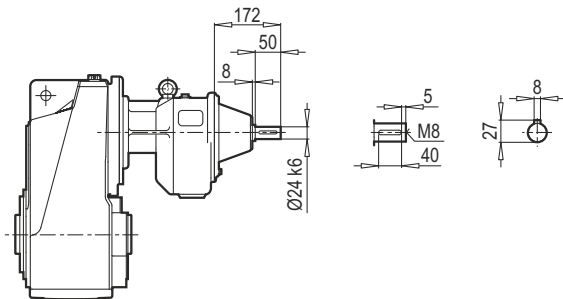

W ~ Kg	
PD/PM 63/22	211
PD/PM 73/22	288
PD/PM 63/32	223
PD/PM 73/32	299
PD/PM 83/32	435

PD 63/22 PD 63/32
PD 73/22 PD 73/32
PD 83/32

PAM B5/B14

PM 63/22 PM 63/32
PM 73/22 PM 73/32
PM 83/32

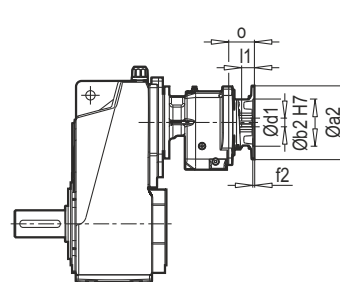
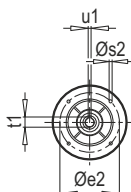
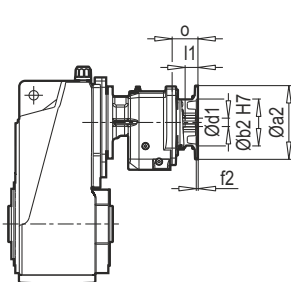

Tip / Type	PAM B5	Øa2	Øb2	Øe2	f2	Øs2	Ød1	l1	t1	u1	o
PD/PM 63/22 - 73/22 - 83/32	71	160	110	130	4.0	M8	14	30	16.3	5	88
PD/PM 63/22 - 73/22 - 83/32	80	200	130	165	4.0	M10	19	40	21.8	6	72
PD/PM 63/22 - 73/22 - 63/32 - 73/32 - 83/32	90	200	130	165	4.0	M10	24	50	27.3	8	72
PD/PM 63/22 - 73/22 - 63/32 - 73/32 - 83/32	100	250	180	215	5.0	M12	28	60	31.3	8	75
PD/PM 63/22 - 73/22 - 63/32 - 73/32 - 83/32	112	250	180	215	5.0	M12	28	60	31.3	8	75
PD/PM 63/32 - 73/32 - 83/32	132	300	230	265	5.0	M12	38	80	41.3	10	94

~ Kg					
PAM B5	PD/PM 63/22	PD/PM 73/22	PD/PM 63/32	PD/PM 73/32	PD/PM 83/32
71	198	271	-	-	407
80	199	272	-	-	408
90	199	272	210	283	408
100	200	273	211	284	409
112	200	273	211	284	409
132	-	-	221	294	419

Tip / Type	PAM B14	Øa2	Øb2	Øe2	f2	Øs2	Ød1	l1	t1	u1	o
PD/PM 63/22 - 73/22 - 83/32	71	105	70	85	4	7	14	30	16.3	5	55
PD/PM 63/22 - 73/22 - 83/32	80	120	80	100	4	7	19	40	21.8	6	72
PD/PM 63/22 - 73/22 - 63/32 - 73/32 - 83/32	90	140	95	115	4	9	24	50	27.3	8	72
PD/PM 63/22 - 73/22 - 63/32 - 73/32 - 83/32	100	160	110	130	5	9	28	60	31.3	8	75
PD/PM 63/22 - 73/22 - 63/32 - 73/32 - 83/32	112	160	110	130	5	9	28	60	31.3	8	75
PD/PM 63/32 - 73/32 - 83/32	132	200	130	165	5	11	38	80	41.3	10	94

~ Kg					
PAM B14	PD/PM 63/22	PD/PM 73/22	PD/PM 63/32	PD/PM 73/32	PD/PM 83/32
71	196	269	-	-	405
80	197	270	-	-	406
90	197	270	208	281	406
100	199	272	210	283	408
112	199	272	210	283	408
132	-	-	214	287	412

PD 83/42 PD 93/52
PD 93/42 PD 103/52
PD 113/52

PM 83/42 PM 93/52
PM 93/42 PM 103/52
PM 113/52

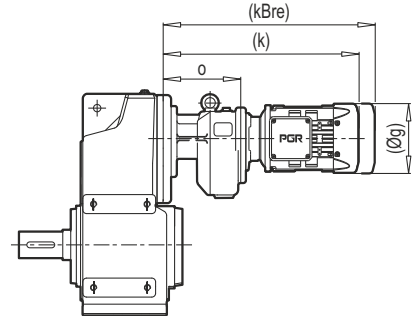
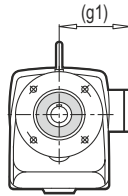
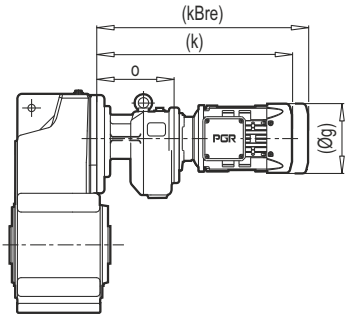

Tip / Type	Motor	g	g1	h2	o	k	kBre
PD/PM 83/42	90 S	193	151	179	262	527	600
	90 L	193	151			547	620
	100 L	217	160			575	656
	112 M	232	168			620	700
PD/PM 93/42	90 S	193	151	179	262	527	600
	90 L	193	151			547	620
	100 L	217	160			575	656
	112 M	232	168			620	700
	132 S	279	182			627	735
	132 M	279	182			662	770
PD/PM 93/52 PD/PM 103/52 PD/PM 113/52	100 L	217	160	218	301	614	695
	112 M	232	168			659	739
	132 S	279	182			666	774
	132 M	279	182			701	809
	160 M/L	323	200			806	958
	180 M/L	370	248			880	1042

Not : (...) İşaretli olan ölçüler Motor markasına göre farklılık gösterir.
Note : The dimensions which have (...) sign vary depending on the motor brand.

PD 83/42 PD 93/52
PD 93/42 PD 103/52
PD 113/52

IEC

PM 83/42 PM 93/52
PM 93/42 PM 103/52
PM 113/52

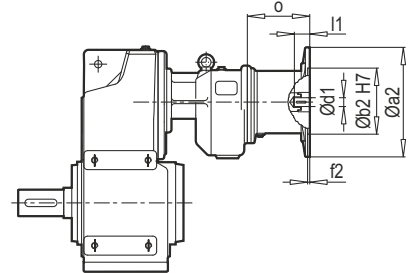
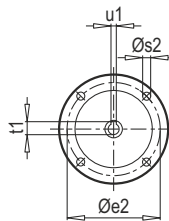
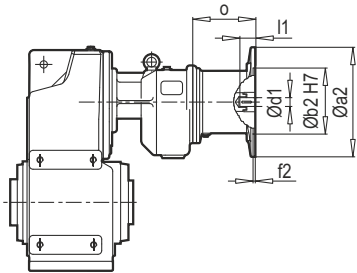

Tip / Type	IEC	Øa2	Øb2	Øe2	f2	Øs2	Ød1	l1	t1	u1	o	~ Kg					
												IEC	PD/PM 83/42	PD/PM 93/42	PD/PM 93/52	PD/PM 103/52	PD/PM 113/52
PD/PM 83/42 - 93/42 - 103/52 - 113/52	90	200	130	165	4.0	M10	24	50	27.3	8	109	90	456	28	40	57	73
PD/PM 83/42 - 93/42 - 93/52 - 103/52 - 113/52	100	250	180	215	5.0	M12	28	60	31.3	8	133	100	463	29	41	58	74
PD/PM 83/42 - 93/42 - 93/52 - 103/52 - 113/52	112	250	180	215	5.0	M12	28	60	31.3	8	133	112	463	32	44	61	77
PD/PM 83/42 - 93/42 - 93/52 - 103/52 - 113/52	132	300	230	265	5.0	M12	38	80	41.3	10	190	132	478	32	44	61	77
PD/PM 83/42 - 93/42 - 93/52 - 103/52 - 113/52	160	350	250	300	6.0	M16	42	110	45.3	12	194	160	489	-	-	69	84
PD/PM 93/52 - 103/52 - 113/52	180	350	250	300	6.0	M16	48	110	51.8	14	194	180	489	-	-	69	84

PD 93/42 PD 93/52
PD 103/52
PD 113/52

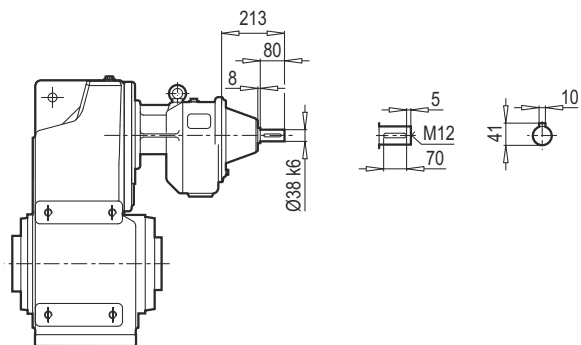

W

PM 93/42 PM 93/52
PM 103/52
PM 113/52

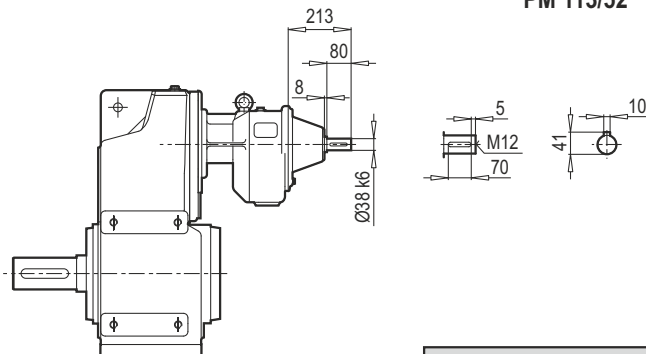

W ~ Kg	
PD/PM 93/42	781
PD/PM 93/52	812
PD/PM 103/52	1410
PD/PM 113/52	2298

PD 93/42 PD 93/52
PD 103/52
PD 113/52

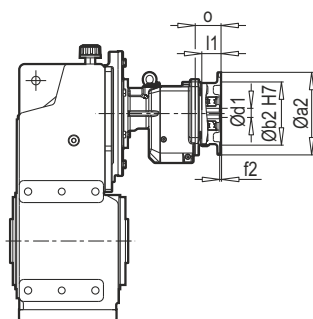

PAM B5/B14

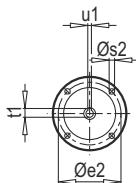

PM 93/42 PM 93/52
PM 103/52
PM 113/52

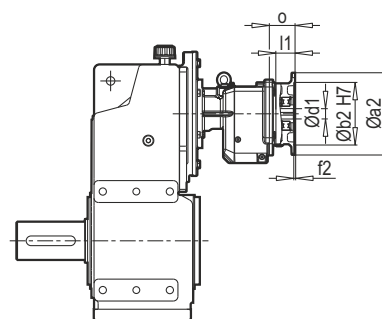

Tip / Type	PAM B5	Øa2	Øb2	Øe2	f2	Øs2	Ød1	l1	t1	u1	o
PD/PM 93/42 - 103/52 - 113/52	90	200	130	165	4.0	M10	24	50	27.3	8	72
PD/PM 93/42 - 93/52 - 103/52 - 113/52	100	250	180	215	5.0	M12	28	60	31.3	8	75
PD/PM 93/42 - 93/52 - 103/52 - 113/52	112	250	180	215	5.0	M12	28	60	31.3	8	75
PD/PM 93/42 - 93/52 - 103/52 - 113/52	132	300	230	265	5.0	M12	38	80	41.3	10	94
PD/PM 93/42 - 93/52 - 103/52 - 113/52	160	350	250	300	6.0	M16	42	110	45.3	12	120
PD/PM 93/52 - 103/52 - 113/52	180	350	250	300	6.0	M16	48	110	51.8	14	120

~ Kg				
PAM B5	PD/PM 93/42	PD/PM 93/52	PD/PM 103/52	PD/PM 113/52
90	728	-	1321	2159
100	729	758	1322	2160
112	729	758	1322	2160
132	738	767	1331	2169
160	746	775	1338	2177
180	746	-	1338	2177

Tip / Type	PAM B14	Øa2	Øb2	Øe2	f2	Øs2	Ød1	l1	t1	u1	o
PD/PM 93/42 - 103/52 - 113/52	90	140	95	115	4.0	9	24	50	27.3	8	72
PD/PM 93/42 - 93/52 - 103/52 - 113/52	100	160	110	130	5.0	9	28	60	31.3	8	75
PD/PM 93/42 - 93/52 - 103/52 - 113/52	112	160	110	130	5.0	9	28	60	31.3	8	75
PD/PM 93/42 - 93/52 - 103/52 - 113/52	132	200	130	165	5.0	11	38	80	41.3	10	94

~ Kg				
PAM B14	PD/PM 93/42	PD/PM 93/52	PD/PM 103/52	PD/PM 113/52
90	727	-	1320	2159
100	728	757	1321	2160
112	728	757	1321	2160
132	733	762	1326	2165

W - IEC ve PAM Adaptörü Seçim Tabloları

Selection of W - IEC and
PAM Adapters

PD/PM

PD SERİSİ
PD SERIE

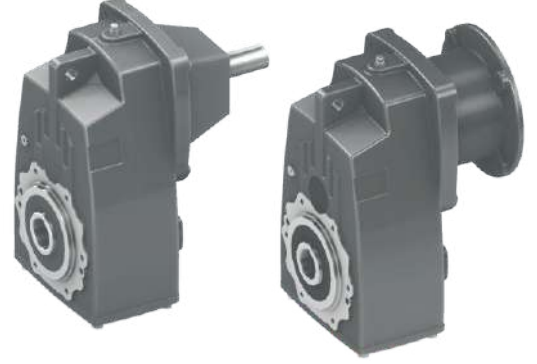

PM SERİSİ
PM SERIE

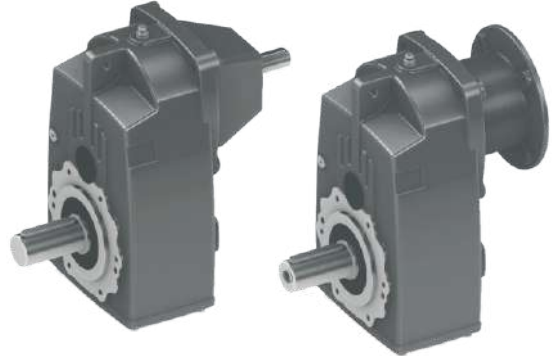

PD SERİSİ
PD SERIE

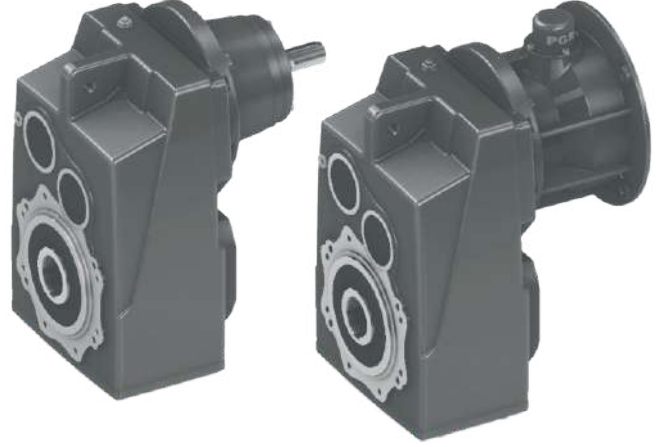

PM SERİSİ
PM SERIE



W - IEC ve PAM adaptörü için performans tablolarının yapısı

Performance tables for W - IEC and PAM adapter type

PD 32
PM 32

Redüktör Tipi ve Büyüklüğü / Gear unit type and size

Motor gövde büyüklüğü ile IEC gövde büyüklüğü aynı olan IEC montajlı redüktörler için Servis faktörü f_B motor seçim sayfalarından alınabilir.

Service factor f_B could be checked from selection of geared motor tables. Because this value is the same for geared motor and geared motor with IEC adapters.

IEC motor büyüklükleri ve IEC standart çıkışları DIN 50347' e göredir.

According to DIN EN 50347 IEC motor sizes.

Tip Type	İges	4-pol. 50 Hz 1400 rpm n_2 [min ⁻¹]	M_{amax} $f_B=1$ 4 - pol. [Nm]	Max. Giriş Gücü / Max. Input Power				IEC - PAM		DIN 42677' ye göre IEC Adaptöre Bağlanacak Motor Boyutu The motor size that will be connected to IEC adapter according to DIN 42677.	
				P_{1max}	W	$f_B \geq 1$		f_B			
				4 - pol. 1400 rpm [kW]	6 - pol. 930 rpm [kW]	8 - pol. 700 rpm [kW]	12 - pol. 465 rpm [kW]				
PD 32 PM 32	112.23	12.50	770	1.01	0.67	0.50	0.33	71	80	90*	
	100.85	13.90	807	1.17	0.78	0.59	0.39	71	80	90*	
	88.74	15.80	945	1.56	1.04	0.78	0.52		80	90	
	79.75	17.60	850	1.56	1.04	0.78	0.52		80	90	
	70.52	19.90	564	1.17	0.78	0.59	0.39	71	80	90*	
	65.91	21.20	758	1.69	1.12	0.84	0.56		80	90	
	64.11	21.80	1015	2.32	1.54	1.16	0.77				
					9.20	6.07	4.60	3.04			
					9.20	6.07	4.60	3.04			

Tip W azami tahrik gücü hesaplanırken *italik* olmayan değerler alınmıştır. P_{1max} ile $f_B = 1$
 P_{1max} value which is *non-italic* is calculated when service factor f_B is equal to one.

P_{1max} hesaplanırken *italik* olan değerlerde $f_B > 1$ alınmıştır.
 P_{1max} value which is *italic*, is calculated when service factor f_B is greater than one.

Max. çıkış momenti
Max. output torque
while service factor $f_B = 1$

Çıkış Devri
Output speed

Redüktör Tahvili
Reduction ratio





Redüktör Tipi ve Büyüklüğü
Gear unit type and size

Yıldız işareti : Dikkat
Tip W sütunundaki P_{1max} değerlerini aşmamalıdır.
Star sign is shown precautions which is value of P_{1max} must be greater than drive power.

71	80
71	80
	80
	80
	80

Rakamlı alanlar IEC adaptörünün, IEC motor büyüklüğü ve tahvil oranına uygun olduğunu belirtir.
This area which is colorless is shown IEC adapter is applicable for this IEC motor size and reduction ratio

W - IEC - PAM





Tip Type	İges	4-pol. 50 Hz 1400 rpm n ₂ [min ⁻¹]	M _{amax} f _B =1 4 - pol. [Nm]	Max. Giriş Gücü / Max. Input Power				IEC - PAM				DIN 42677' ye göre IEC Adaptöre Bağlanacak Motor Boyutu								
				P _{1max} W f _B ≥ 1				f _B ⇔ 69 - 108				The motor size that will be connected to IEC adapter according to DIN 42677.								
				4 - pol. 1400 rpm [kW]	6 - pol. 930 rpm [kW]	8 - pol. 700 rpm [kW]	12 - pol. 465 rpm [kW]													
PD A02 PM A02  W  IEC - PAM	81.73	17.10	65	0.12	0.08	0.06	0.04	63												
	59.32	23.60	110	0.27	0.18	0.14	0.09	63	71*											
	49.62	28.20	100	0.30	0.20	0.15	0.10	63	71*											
	41.88	33.40	85	0.30	0.20	0.15	0.10	63	71*											
	37.71	37.10	100	0.39	0.26	0.19	0.13	63	71	80*										
	34.80	40.20	103	0.43	0.29	0.22	0.14	63	71	80*										
	31.83	44.00	95	0.44	0.29	0.22	0.15	63	71	80*										
	29.11	48.10	110	0.55	0.37	0.28	0.18	63	71	80*										
	24.57	57.00	116	0.69	0.46	0.35	0.23	63	71	80*										
	22.34	62.70	109	0.72	0.48	0.36	0.24	63	71	80*										
	18.77	74.60	95	0.74	0.49	0.37	0.25	63	71	80										
	16.54	84.60	100	0.89	0.59	0.44	0.29	63	71	80	90*									
	14.91	93.90	75	0.74	0.49	0.37	0.24	63	71	80*										
	13.83	101.20	110	1.17	0.77	0.58	0.39	63	71	80	90*									
	11.67	120.00	110	1.38	0.92	0.69	0.46	63	71	80	90*									
	9.49	147.50	110	1.50	0.99	0.75	0.50	63	71	80	90									
	8.63	162.20	114	1.50	0.99	0.75	0.50	63	71	80	90									
	7.25	193.10	112	1.50	0.99	0.75	0.50	63	71	80	90									
	6.35	220.50	110	1.50	0.99	0.75	0.50	63	71	80	90									
	5.33	262.70	92	1.50	0.99	0.75	0.50	63	71	80	90									
4.24	330.20	73	1.50	0.99	0.75	0.50	63	71	80	90										
PD B02 PM B02  W  IEC - PAM	139.15	10.10	110	0.12	0.08	0.06	0.04	63*												
	103.09	13.60	129	0.18	0.12	0.09	0.06	63	71*											
	85.67	16.30	140	0.24	0.16	0.12	0.08	63	71*											
	79.42	17.60	129	0.24	0.16	0.12	0.08	63	71*	80*										
	66.00	21.20	140	0.31	0.21	0.16	0.10	63	71*	80*										
	56.55	24.80	160	0.41	0.28	0.21	0.14	63	71	80*										
	51.60	27.10	146	0.41	0.28	0.21	0.14	63	71	80*										
	44.23	31.70	164	0.54	0.36	0.27	0.18	63	71	80*										
	40.35	34.70	165	0.60	0.40	0.30	0.20	63	71	80*										
	34.16	41.00	153	0.66	0.44	0.33	0.22	63	71	80*										
	30.08	46.50	129	0.63	0.42	0.31	0.21	63	71	80*	90*									
	25.96	53.90	129	0.73	0.48	0.36	0.24	63	71	80*	90*									
	22.68	61.70	129	0.83	0.55	0.42	0.28	63	71	80	90*									
	21.58	64.90	140	0.95	0.63	0.48	0.32	63	71	80	90*									
	19.94	70.20	129	0.95	0.63	0.47	0.32	63	71	80	90*									
	17.62	79.50	129	1.07	0.71	0.54	0.36	63	71	80	90*									
	16.57	84.50	140	1.24	0.82	0.62	0.41	63	71	80	90*									
	14.20	98.60	163	1.50	0.99	0.75	0.50	63	71	80	90									
	12.96	108.00	160	1.50	0.99	0.75	0.50	63	71	80	90									
	11.28	124.10	140	1.50	0.99	0.75	0.50	63	71	80	90									
10.97	127.60	152	1.50	0.99	0.75	0.50	63	71	80	90										
9.67	144.80	141	1.50	0.99	0.75	0.50	63	71	80	90										
8.82	158.70	138	1.50	0.99	0.75	0.50	63	71	80	90										
7.47	187.40	131	1.50	0.99	0.75	0.50	63	71	80	90										
6.43	217.70	123	1.50	0.99	0.75	0.50	63	71	80	90										
6.00	233.30	121	1.50	0.99	0.75	0.50	63	71	80	90										
5.17	270.80	114	1.50	0.99	0.75	0.50	63	71	80	90										
4.67	299.80	110	1.50	0.99	0.75	0.50	63	71	80	90										
4.02	348.30	103	1.50	0.99	0.75	0.50	63	71	80	90										

IEC - PAM bağlantısı yoktur - No IEC - PAM assembling on empty fields

63 IEC - PAM bağlantısı yapılır - IEC - PAM assembling available on numbered fields

80* IEC - PAM bağlantısı yapılacaksa P_{1max} değerleri aşılmamalıdır - Do not exceed the P_{1max} values indicated on fields with asterisk

W - IEC - PAM

Tip Type	İges	4-pol. 50 Hz 1400 rpm n ₂ [min ⁻¹]	M _{amax} f _B =1 4 - pol. [Nm]	Max. Giriş Gücü / Max. Input Power				IEC - PAM				DIN 42677' ye göre IEC Adaptöre Bağlanacak Motor Boyutu The motor size that will be connected to IEC adapter according to DIN 42677.	
				P _{1max} W f _B ≥ 1				f _B ⇔ 69 - 108					
				4 - pol. 1400 rpm [kW]	6 - pol. 930 rpm [kW]	8 - pol. 700 rpm [kW]	12 - pol. 465 rpm [kW]	63*	71*				
PD 12/02 PM 12/02  W mm 165 + IEC - PAM  W mm 164-165	3607.45	0.39	290	0.05	0.03	0.03	0.02	63*	71*				
	2448.00	0.57	290	0.06	0.04	0.03	0.02	63*	71*				
	1965.82	0.71	290	0.06	0.04	0.03	0.02	63*	71*				
	1621.40	0.86	290	0.07	0.04	0.03	0.02	63*	71*				
	1363.09	1.00	290	0.07	0.05	0.04	0.02	63*	71*				
	1064.65	1.30	290	0.08	0.05	0.04	0.03	63*	71*	80*	90*		
	824.73	1.70	290	0.09	0.06	0.05	0.03	63*	71*	80*	90*		
	662.28	2.10	290	0.10	0.07	0.05	0.03	63*	71*	80*	90*		
	546.25	2.60	290	0.12	0.08	0.06	0.04	63*	71*	80*	90*		
	405.92	3.40	290	0.14	0.09	0.07	0.05	63*	71*	80*	90*		
328.02	4.30	290	0.17	0.11	0.08	0.06	63*	71*	80*	90*			
284.03	4.90	290	0.19	0.12	0.09	0.06	63	71*	80*	90*			
229.52	6.10	290	0.23	0.15	0.11	0.07	63	71*	80*	90*			
PD C13 PM C13  W mm 117 + IEC - PAM  W mm 117	380.81	3.70	370	0.14	0.09	0.07	0.05	63*	71*				
	301.44	4.60	370	0.18	0.12	0.09	0.06	63	71*	80*	90*		
	257.36	5.40	370	0.21	0.14	0.11	0.07	63	71*				
	203.72	6.90	370	0.27	0.18	0.13	0.09	63	71*	80*	90*		
	158.21	8.80	370	0.34	0.23	0.17	0.11	63	71*	80*	90*		
	136.54	10.30	370	0.40	0.26	0.20	0.13	63	71	80*	90*		
	118.07	11.90	370	0.46	0.30	0.23	0.15	63	71	80*	90*		
	106.03	13.20	370	0.51	0.34	0.26	0.17	63	71	80*	90*		
	101.01	13.90	370	0.54	0.36	0.27	0.18	63	71	80*	90*		
	88.92	15.70	370	0.61	0.41	0.30	0.20	63	71	80*	90*		
	78.83	17.80	370	0.69	0.46	0.34	0.23	63	71	80*	90*	100*	
	68.27	20.50	370	0.79	0.53	0.40	0.26	63	71	80	90*		
	60.09	23.30	370	0.90	0.60	0.45	0.30	63	71	80	90*		
	53.28	26.30	357	0.98	0.65	0.49	0.33	63	71	80	90*	100*	
	44.33	31.60	337	1.11	0.74	0.56	0.37	63	71	80	90*	100*	
	38.83	36.10	324	1.23	0.81	0.61	0.41	63	71	80	90*	100*	
	35.71	39.20	300	1.23	0.82	0.62	0.41	63	71	80	90*	100*	
	29.71	47.10	282	1.39	0.92	0.69	0.46	63	71	80	90*	100*	
	26.02	53.80	271	1.53	1.01	0.76	0.51	63	71	80	90	100*	
	24.17	57.90	277	1.67	1.11	0.84	0.56			80	90	100*	
18.76	74.60	243	1.90	1.26	0.95	0.63			80	90	100*		
16.20	86.40	231	2.08	1.38	1.04	0.69			80	90	100*		

IEC - PAM bağlantısı yoktur - No IEC - PAM assembling on empty fields

63 IEC - PAM bağlantısı yapılır - IEC - PAM assembling available on numbered fields

80* IEC - PAM bağlantısı yapılacaksa P_{1max} değerleri aşılmamalıdır - Do not exceed the P_{1max} values indicated on fields with asterisk

W - IEC - PAM







Tip Type	İges	4-pol. 50 Hz 1400 rpm n ₂ [min ⁻¹]	M _{amax} f _B =1 4 - pol. [Nm]	Max. Giriş Gücü / Max. Input Power P _{1max} W f _B ≥ 1				IEC - PAM		DIN 42677' ye göre IEC Adaptöre Bağlanacak Motor Boyutu					
				4 - pol. 1400 rpm [kW]	6 - pol. 930 rpm [kW]	8 - pol. 700 rpm [kW]	12 - pol. 465 rpm [kW]	f _B ⇔	69 - 108	The motor size that will be connected to IEC adapter according to DIN 42677.					
PD 13 PM 13	633.80	2.20	222	0.05	0.03	0.03	0.02	63*	71*						
	556.59	2.50	225	0.06	0.04	0.03	0.02	63*	71*						
	472.42	3.00	225	0.07	0.05	0.03	0.02	63*	71*						
	W mm ↔	414.87	3.40	225	0.08	0.05	0.04	0.03	63*	71*					
	↔ 120	368.83	3.80	225	0.09	0.06	0.04	0.03	63*	71*					
	+	301.08	4.60	270	0.13	0.09	0.07	0.04	63*	71*					
		251.58	5.60	274	0.16	0.11	0.08	0.05	63*	71*					
	IEC - PAM	209.76	6.70	235	0.16	0.11	0.08	0.05	63*	71*					
	↔ mm	163.92	8.50	225	0.20	0.13	0.10	0.07	63	71*					
	↔ 120-121	129.01	10.90	225	0.26	0.17	0.13	0.08	63	71*					
	105.32	13.30	270	0.37	0.24	0.19	0.12	63	71						
	88.00	15.90	274	0.37	0.24	0.19	0.12	63	71						
PD 12 PM 12	109.45	12.80	209	0.28	0.19	0.14	0.09	63	71*						
	92.43	15.10	232	0.37	0.24	0.18	0.12	63	71*						
	81.17	17.20	296	0.53	0.36	0.27	0.18	63	71						
	W mm ↔	72.16	19.40	296	0.60	0.40	0.30	0.20		71	80*	90*			
	↔ 120	66.26	21.10	270	0.60	0.40	0.30	0.20	63	71					
	+	58.91	23.80	283	0.70	0.47	0.35	0.23		71	80*	90*			
		55.37	25.30	235	0.62	0.41	0.31	0.21	63	71					
	IEC - PAM	49.22	28.40	260	0.77	0.51	0.39	0.26		71	80	90*			
	↔ mm	46.16	30.30	196	0.62	0.41	0.31	0.21	63	71					
	↔ 120-121	41.04	34.10	217	0.78	0.51	0.39	0.26		71	80	90*			
		32.07	43.70	230	1.05	0.70	0.53	0.35	63	71	80	90*			
		28.35	49.40	225	1.16	0.77	0.58	0.39	63	71	80	90*			
		25.24	55.50	225	1.31	0.87	0.65	0.43	63	71	80	90*	100*	112*	
		20.61	67.90	225	1.60	1.06	0.80	0.53	63	71	80	90	100*	112*	
		17.22	81.30	224	1.91	1.27	0.95	0.63	63	71	80	90	100*	112*	
		14.09	99.40	210	2.18	1.45	1.09	0.73	63	71	80	90	100*	112*	
		11.75	119.10	204	2.55	1.69	1.27	0.85	63	71	80	90	100*	112*	
		10.34	135.40	196	2.78	1.85	1.39	0.92	63	71	80	90	100*	112*	
		9.16	152.80	189	3.02	2.01	1.51	1.00	63	71	80	90	100	112*	
		8.23	170.10	191	3.40	2.26	1.70	1.13	63	71	80	90	100*	112*	
	8.18	171.10	160	2.87	1.90	1.43	0.95	63	71	80	90	100	112*		
	7.25	193.10	187	3.78	2.51	1.89	1.26	63	71	80	90	100	112*		
	6.42	218.10	181	4.00	2.64	2.00	1.32	63	71	80	90	100	112		
	5.47	255.90	172	4.00	2.64	2.00	1.32	63	71	80	90	100	112		
	4.78	292.90	128	3.93	2.61	1.96	1.30	63	71	80	90	100	112*		

IEC - PAM bağlantısı yoktur - No IEC - PAM assembling on empty fields

63 IEC - PAM bağlantısı yapılır - IEC - PAM assembling available on numbered fields

80* IEC - PAM bağlantısı yapılacaksa P_{1max} değerleri aşılmamalıdır - Do not exceed the P_{1max} values indicated on fields with asterisk

W - IEC - PAM

Tip Type	İges	4-pol. 50 Hz 1400 rpm n ₂ [min ⁻¹]	M _{amax} f _B =1 4 - pol. [Nm]	Max. Giriş Gücü / Max. Input Power P _{1max} W f _B ≥ 1				IEC - PAM				DIN 42677' ye göre IEC Adaptöre Bağlanacak Motor Boyutu					
				4 - pol. 1400 rpm [kW]	6 - pol. 930 rpm [kW]	8 - pol. 700 rpm [kW]	12 - pol. 465 rpm [kW]	f _B ⇔ 69 - 108				The motor size that will be connected to IEC adapter according to DIN 42677.					
PD 22/02 PM 22/02  W  165 + IEC - PAM  164-165	3425.64	0.41	520	0.06	0.04	0.03	0.02	63*	71*								
	2653.67	0.53	520	0.07	0.04	0.03	0.02	63*	71*								
	2130.98	0.66	520	0.08	0.05	0.04	0.02	63*	71*								
	1726.36	0.81	520	0.08	0.05	0.04	0.03	63*	71*								
	1423.90	0.98	520	0.09	0.06	0.05	0.03	63*	71*								
	1065.19	1.30	520	0.11	0.07	0.06	0.04	63*	71*	80*	90*						
	825.15	1.70	520	0.13	0.09	0.07	0.04	63*	71*	80*	90*						
	662.62	2.10	520	0.16	0.10	0.08	0.05	63*	71*	80*	90*						
	514.10	2.70	520	0.20	0.12	0.10	0.06	63	71*	80*	90*						
	424.03	3.30	520	0.22	0.14	0.11	0.07	63	71*	80*	90*						
	356.48	3.90	520	0.25	0.17	0.13	0.08	63	71*	80*	90*						
	288.06	4.90	520	0.30	0.20	0.15	0.10	63	71*	80*	90*						
	216.66	6.50	520	0.39	0.26	0.20	0.13	63	71	80*	90*						
	175.52	8.00	520	0.47	0.31	0.24	0.16	63	71	80*	90*						
PD 23 PM 23  W  124 + IEC - PAM  124-125	762.96	1.80	438	0.08	0.06	0.04	0.03	63*	71*								
	622.96	2.20	521	0.12	0.08	0.06	0.04	63*	71*								
	482.49	2.90	521	0.16	0.11	0.08	0.05	63*	71*								
	390.87	3.60	521	0.20	0.13	0.10	0.06	63	71*								
	330.43	4.20	563	0.25	0.17	0.12	0.08	63	71*								
	276.32	5.10	553	0.29	0.19	0.15	0.10	63	71*								
	235.73	5.90	473	0.29	0.20	0.15	0.10	63	71*								
	185.19	7.60	521	0.41	0.27	0.21	0.14	63	71	80*	90*						
	150.03	9.30	521	0.51	0.34	0.25	0.17	63	71	80*	90*						
	131.68	10.60	521	0.58	0.39	0.29	0.19	63	71	80*	90*						
	116.40	12.00	521	0.66	0.44	0.33	0.22	63	71	80*	90*						
	98.40	14.20	563	0.75	0.50	0.38	0.25	63	71	80	90*						
	82.29	17.00	561	0.75	0.50	0.38	0.25	63	71	80	90*						

IEC - PAM bağlantısı yoktur - No IEC - PAM assembling on empty fields

63 IEC - PAM bağlantısı yapılır - IEC - PAM assembling available on numbered fields

80* IEC - PAM bağlantısı yapılacaksa P_{1max} değerleri aşılmamalıdır - Do not exceed the P_{1max} values indicated on fields with asterisk

W - IEC - PAM







Tip Type	İges	4-pol. 50 Hz 1400 rpm n ₂ [min ⁻¹]	M _{amax} f _B =1 4 - pol. [Nm]	Max. Giriş Gücü / Max. Input Power P _{1max} W f _B ≥ 1				IEC - PAM		DIN 42677' ye göre IEC Adaptöre Bağlanacak Motor Boyutu				
				4 - pol. 1400 rpm [kW]	6 - pol. 930 rpm [kW]	8 - pol. 700 rpm [kW]	12 - pol. 465 rpm [kW]	f _B ⇔	69 - 108	The motor size that will be connected to IEC adapter according to DIN 42677.				
PD 22 PM 22	127.46	11.00	380	0.44	0.29	0.22	0.15	71	80*					
	104.07	13.50	397	0.56	0.37	0.28	0.19	71	80*					
W mm 124	100.98	13.90	440	0.64	0.42	0.32	0.21	71	80*	90*				
	82.45	17.00	477	0.85	0.56	0.42	0.28	71	80	90*				
+	69.70	20.10	443	0.93	0.62	0.47	0.31	71	80	90*				
	63.86	21.90	521	1.20	0.79	0.60	0.40		80	90*				
IEC - PAM mm 124-125	53.98	25.90	506	1.37	0.91	0.69	0.46		80	90*				
	51.73	27.10	521	1.48	0.98	0.74	0.49		80	90*	100*	112*		
+	45.14	31.00	450	1.46	0.97	0.73	0.49		80	90*				
	43.73	32.00	563	1.89	1.25	0.94	0.63		80	90	100*	112*		
W mm 124-125	37.18	37.70	460	1.81	1.20	0.91	0.60	71	80					
	36.57	38.30	501	2.01	1.33	1.00	0.67		80	90	100*	112*		
+	31.20	44.90	445	2.09	1.39	1.05	0.69		80	90	100*	112*		
	29.64	47.20	500	2.47	1.64	1.24	0.82	71	80	90	100*	112*		
IEC - PAM mm 124-125	26.81	52.20	439	2.40	1.59	1.20	0.80	71	80	90	100*	112*		
	24.98	56.00	490	2.88	1.91	1.44	0.96	71	80	90	100*	112*		
+	23.99	58.40	435	2.66	1.77	1.33	0.88	71	80	90	100*	112*		
	21.89	64.00	480	3.21	2.14	1.61	1.07	71	80	90	100	112*		
IEC - PAM mm 124-125	18.51	75.60	486	3.85	2.56	1.92	1.28	71	80	90	100	112*		
	16.56	84.50	471	4.00	2.64	2.00	1.32	71	80	90	100	112		
+	13.20	106.10	405	4.00	2.64	2.00	1.32	71	80	90	100	112		
	11.81	118.50	384	4.00	2.64	2.00	1.32	71	80	90	100	112		
IEC - PAM mm 124-125	10.16	137.80	356	4.00	2.64	2.00	1.32	71	80	90	100	112		
	9.00	155.60	335	4.00	2.64	2.00	1.32	71	80	90	100	112		
+	8.36	167.50	256	4.00	2.64	2.00	1.32	71	80	90	100	112		
	7.48	187.20	243	4.00	2.64	2.00	1.32	71	80	90	100	112		
IEC - PAM mm 124-125	6.43	217.70	226	4.00	2.64	2.00	1.32	71	80	90	100	112		
	5.70	245.60	212	4.00	2.64	2.00	1.32	71	80	90	100	112		
+	4.51	310.40	186	4.00	2.64	2.00	1.32			90	100	112		

IEC - PAM bağlantısı yoktur - No IEC - PAM assembling on empty fields

63 IEC - PAM bağlantısı yapılır - IEC - PAM assembling available on numbered fields

80* IEC - PAM bağlantısı yapılacaksa P_{1max} değerleri aşılmamalıdır - Do not exceed the P_{1max} values indicated on fields with asterisk

W - IEC - PAM

Tip Type	İges	4-pol. 50 Hz 1400 rpm n ₂ [min ⁻¹]	M _{amax} f _B =1 4 - pol. [Nm]	Max. Giriş Gücü / Max. Input Power				IEC - PAM		DIN 42677' ye göre IEC Adaptöre Bağlanacak Motor Boyutu			
				P _{1max} W f _B ≥ 1				f _B ⇔ 69 - 108		The motor size that will be connected to IEC adapter according to DIN 42677.			
				4 - pol. 1400 rpm [kW]	6 - pol. 930 rpm [kW]	8 - pol. 700 rpm [kW]	12 - pol. 465 rpm [kW]						
PD 32/12 PM 32/12  W  165 + IEC - PAM  164-165	3434.69	0.41	900	0.08	0.05	0.04	0.03	63*	71*				
	2794.50	0.50	900	0.09	0.06	0.04	0.03	63*	71*				
	2246.56	0.62	900	0.10	0.06	0.05	0.03	63*	71*				
	1696.40	0.83	900	0.12	0.08	0.06	0.04	63*	71*	80*	90*		
	1335.13	1.00	900	0.14	0.09	0.07	0.05	63*	71*	80*	90*	100*	112*
	1068.11	1.30	900	0.16	0.11	0.08	0.05	63*	71*	80*	90*	100*	112*
	851.83	1.60	900	0.19	0.13	0.10	0.06	63	71*	80*	90*	100*	112*
	684.80	2.00	900	0.23	0.15	0.12	0.08	63	71*	80*	90*	100*	112*
	521.00	2.70	900	0.29	0.19	0.15	0.10	63	71*	80*	90*	100*	112*
	461.30	3.00	900	0.33	0.21	0.16	0.11	63	71*	80*	90*	100*	112*
	358.19	3.90	900	0.41	0.27	0.20	0.13	63	71	80*	90*	100*	112*
	270.47	5.20	900	0.53	0.35	0.26	0.17	63	71	80*	90*	100*	112*
	217.44	6.40	900	0.65	0.43	0.32	0.21	63	71	80*	90*	100*	112*
	179.71	7.80	900	0.77	0.51	0.39	0.26	63	71	80	90*	100*	112*
	141.42	9.90	900	0.93	0.62	0.47	0.31	63	71	80	90*	100*	112*
	114.01	12.30	900	1.16	0.77	0.58	0.38	63	71	80	90*	100*	112*
	87.71	16.00	900	1.50	1.00	0.75	0.50	63	71	80	90	100*	112*
	PD 33 PM 33  W  128 + IEC - PAM  128-129	1022.54	1.40	787	0.11	0.07	0.06	0.04	63*	71*			
918.90		1.50	822	0.13	0.09	0.07	0.04	63*	71*				
808.52		1.70	1039	0.19	0.13	0.09	0.06	63	71*				
726.57		1.90	944	0.19	0.13	0.10	0.06	63	71*				
584.11		2.40	1000	0.25	0.17	0.13	0.08	63	71*				
482.75		2.90	866	0.26	0.17	0.13	0.09	63	71*				
408.42		3.40	796	0.29	0.19	0.14	0.09	63	71*				
287.08		4.90	938	0.48	0.32	0.24	0.16	63	71	80*	90*		
230.79		6.10	1000	0.64	0.42	0.32	0.21	63	71	80*	90*		
190.74		7.30	866	0.67	0.44	0.33	0.22	63	71	80*	90*		
161.38		8.70	788	0.72	0.48	0.36	0.24	63	71	80*	90*		
127.01		11.00	774	0.89	0.59	0.45	0.30	63	71	80	90*	100*	112*
103.92		13.50	735	1.04	0.69	0.52	0.34	63	71	80	90*	100*	112*
89.45		16.20	621	1.05	0.68	0.53	0.34	63	71	80	90*	100*	112*

IEC - PAM bağlantısı yoktur - No IEC - PAM assembling on empty fields

63 IEC - PAM bağlantısı yapılır - IEC - PAM assembling available on numbered fields

80* IEC - PAM bağlantısı yapılacaksa P_{1max} değerleri aşılmamalıdır - Do not exceed the P_{1max} values indicated on fields with asterisk

W - IEC - PAM





Tip Type	İges	4-pol. 50 Hz 1400 rpm n ₂ [min ⁻¹]	M _{amax} f _B =1 4 - pol. [Nm]	Max. Giriş Gücü / Max. Input Power				IEC - PAM		DIN 42677' ye göre IEC Adaptöre Bağlanacak Motor Boyutu				
				P _{1max} W f _B ≥ 1				f _B ⇔ 69 - 108		The motor size that will be connected to IEC adapter according to DIN 42677.				
				4 - pol. 1400 rpm [kW]	6 - pol. 930 rpm [kW]	8 - pol. 700 rpm [kW]	12 - pol. 465 rpm [kW]							
PD 32 PM 32	112.23	12.50	770	1.01	0.67	0.50	0.33	71	80	90*				
	100.85	13.90	807	1.17	0.78	0.59	0.39	71	80	90*				
W mm 128	88.74	15.80	945	1.56	1.04	0.78	0.52		80	90				
	79.75	17.60	850	1.56	1.04	0.78	0.52		80	90				
+ IEC - PAM mm 128-129	70.52	19.90	564	1.17	0.78	0.59	0.39	71	80	90*				
	65.91	21.20	758	1.69	1.12	0.84	0.56		80	90				
+	64.11	21.80	1015	2.32	1.54	1.16	0.77		80	90	100*	112*		
	55.76	25.10	642	1.69	1.12	0.84	0.56		80	90				
IEC - PAM mm 128-129	52.98	26.40	845	2.34	1.55	1.17	0.78		80	90	100*	112*		
	48.00	29.20	552	1.69	1.12	0.84	0.56		80	90				
+	44.83	31.20	737	2.41	1.60	1.21	0.80		80	90	100*	112*		
	42.05	33.30	929	3.24	2.15	1.62	1.08	71	80	90	100	112*		
+	38.59	36.30	634	2.41	1.60	1.20	0.80		80	90	100*	112*		
	37.79	37.00	835	3.24	2.15	1.62	1.08	71	80	90	100	112*		
+	31.90	43.90	877	4.03	2.68	2.02	1.34		71	80	90	100	112	
	28.67	48.80	870	4.45	2.96	2.22	1.48		71	80	90	100	112	
+	25.86	54.10	846	4.80	3.19	2.40	1.59		71	80	90	100	112	
	23.69	59.10	805	4.98	3.31	2.49	1.65		71	80	90	100	112	
+	22.42	62.40	800	5.23	3.42	2.62	1.74		71	80	90	100	112	132*
	21.37	65.50	722	4.95	3.29	2.48	1.65		71	80	90	100	112	
+	20.15	69.50	822	5.98	3.97	2.99	1.99		71	80	90	100	112	132*
	16.65	84.10	841	7.40	4.92	3.70	2.46		71	80	90	100	112	132*
+	14.09	99.40	857	8.92	5.92	4.46	2.96		71	80	90	100	112	132*
	11.35	123.30	821	9.20	6.07	4.60	3.04				90	100	112	132
+	9.77	143.30	839	9.20	6.07	4.60	3.04				90	100	112	132
	8.29	168.90	676	9.20	6.07	4.60	3.04	71	80	90	100	112	132	
+	6.68	209.60	607	9.20	6.07	4.60	3.04				90	100	112	132
	5.66	247.30	555	9.20	6.07	4.60	3.04				90	100	112	132
+	4.48	312.50	461	9.20	6.07	4.60	3.04				90	100	112	132

IEC - PAM bağlantısı yoktur - No IEC - PAM assembling on empty fields

63 IEC - PAM bağlantısı yapılır - IEC - PAM assembling available on numbered fields

80* IEC - PAM bağlantısı yapılacaksa P_{1max} değerleri aşılmamalıdır - Do not exceed the P_{1max} values indicated on fields with asterisk

W - IEC - PAM

Tip Type	İges	4-pol. 50 Hz 1400 rpm n ₂ [min ⁻¹]	M _{amax} f _B =1 4 - pol. [Nm]	Max. Giriş Gücü / Max. Input Power				IEC - PAM		DIN 42677' ye göre IEC Adaptöre Bağlanacak Motor Boyutu			
				P _{1max} W f _B ≥ 1				f _B ⇔ 69 - 108		The motor size that will be connected to IEC adapter according to DIN 42677.			
				4 - pol. 1400 rpm [kW]	6 - pol. 930 rpm [kW]	8 - pol. 700 rpm [kW]	12 - pol. 465 rpm [kW]						
PD 42/12 PM 42/12  + IEC - PAM 	2783.90	0.50	1800	0.13	0.09	0.07	0.04	63*	71*				
	2249.64	0.62	1800	0.16	0.10	0.08	0.05	63*	71*				
	1830.33	0.76	1800	0.18	0.12	0.09	0.06	63	71*				
	1343.79	1.00	1800	0.24	0.16	0.12	0.08	63	71*				
	1111.10	1.30	1800	0.28	0.18	0.14	0.09	63	71*	80*	90*		
	874.48	1.60	1800	0.34	0.23	0.17	0.11	63	71*	80*	90*	100*	112*
	699.58	2.00	1800	0.42	0.28	0.21	0.14	63	71	80*	90*	100*	112*
	557.93	2.50	1800	0.51	0.34	0.26	0.17	63	71	80*	90*	100*	112*
	409.62	3.40	1800	0.68	0.45	0.34	0.23	63	71	80*	90*	100*	112*
	341.25	4.10	1800	0.77	0.51	0.39	0.26	63	71	80	90*	100*	112*
	302.14	4.60	1800	0.87	0.58	0.44	0.29	63	71	80	90*	100*	112*
	234.61	6.00	1800	1.12	0.75	0.56	0.37	63	71	80	90*	100*	112*
	177.15	7.90	1800	1.49	0.99	0.74	0.49	63	71	80	90*	100*	112*
	152.50	9.20	1800	1.73	1.15	0.87	0.57	63	71	80	90	100*	112*
	127.43	11.00	1800	2.07	1.38	1.04	0.69	63	71	80	90	100*	112*
	PD 43 PM 43  + IEC - PAM 	1585.08	0.88	1420	0.13	0.09	0.07	0.04	71*	80*	90*		
1129.42		1.20	1600	0.21	0.14	0.10	0.07	71*	80*	90*			
1097.89		1.30	1088	0.15	0.10	0.07	0.05	71*	80*	90*			
782.28		1.80	1476	0.28	0.18	0.14	0.09	71*	80*	90*			
653.66		2.10	1233	0.28	0.18	0.14	0.09	71*	80*	90*			
605.88		2.30	1475	0.36	0.24	0.18	0.12		80*	90*			
532.76		2.60	2000	0.55	0.37	0.28	0.18	71	80*	90*			
445.16		3.10	1666	0.55	0.36	0.27	0.18	71	80*	90*			
412.63		3.40	1990	0.71	0.47	0.35	0.23		80*	90*			
391.14		3.60	2000	0.75	0.50	0.37	0.25	71	80	90*			
344.78		4.10	1662	0.71	0.47	0.35	0.23		80*	90*			
326.83		4.30	1890	0.85	0.56	0.42	0.28	71	80	90*			
302.94		4.60	2077	1.01	0.67	0.50	0.33		80	90*			
272.49		5.10	1572	0.85	0.56	0.42	0.28	71	80	90*			
253.13		5.50	1961	1.14	0.75	0.57	0.38		80	90*			
211.05		6.60	1635	1.14	0.75	0.57	0.38		80	90*			
191.52		7.30	1990	1.52	1.01	0.76	0.51	71	80	90	100*	112*	
160.03		8.70	1657	1.52	1.01	0.76	0.50	71	80	90	100*	112*	
140.61		10.00	2000	2.09	1.39	1.04	0.69	71	80	90	100*	112*	
118.53		11.80	2000	2.47	1.64	1.24	0.82	71	80	90	100*	112*	
103.86	13.50	2000	2.82	1.88	1.41	0.94	71	80	90	100*	112*		
86.78	16.10	1980	3.00	1.98	1.50	0.99	71	80	90	100	112*		

IEC - PAM bağlantısı yoktur - No IEC - PAM assembling on empty fields

63 IEC - PAM bağlantısı yapılır - IEC - PAM assembling available on numbered fields

80* IEC - PAM bağlantısı yapılacaksa P_{1max} değerleri aşılmamalıdır - Do not exceed the P_{1max} values indicated on fields with asterisk

W - IEC - PAM









Tip Type	İges	4-pol. 50 Hz 1400 rpm n ₂ [min ⁻¹]	M _{amax} f _B =1 4 - pol. [Nm]	Max. Giriş Gücü / Max. Input Power				IEC - PAM				DIN 42677' ye göre IEC Adaptöre Bağlanacak Motor Boyutu The motor size that will be connected to IEC adapter according to DIN 42677.		
				P _{1max} W f _B ≥ 1				f _B ⇔ 69 - 108						
				4 - pol. 1400 rpm [kW]	6 - pol. 930 rpm [kW]	8 - pol. 700 rpm [kW]	12 - pol. 465 rpm [kW]	90*	100*	112*	132*			
PD 42 PM 42	155.40	9.00	1275	1.20	0.80	0.60	0.40	90*						
	110.73	12.60	1600	2.12	1.41	1.06	0.70	90	100*	112*				
W ← mm → 132	90.52	15.50	1600	2.59	1.72	1.30	0.86	90	100*	112*				
	75.41	18.60	1589	3.09	2.05	1.54	1.03		100	112*	132*			
+	61.64	22.70	1794	4.27	2.83	2.13	1.42		100	112	132*			
	52.23	26.80	1818	5.10	3.39	2.55	1.69		100	112	132*			
IEC - PAM ← mm → 132-133	45.06	31.10	1594	5.19	3.44	2.59	1.72	90	100	112	132*			
	43.64	32.10	1600	5.37	3.57	2.69	1.79		100	112	132*			
+	40.79	34.30	1556	5.59	3.71	2.80	1.86	90	100	112	132*			
	38.35	36.50	2000	7.65	5.08	3.82	2.54				132*			
+	36.84	38.00	1400	5.57	3.70	2.79	1.85	90	100	112	132*			
	36.39	38.50	1375	5.54	3.68	2.77	1.84		100	112	132*			
+	32.31	43.30	1620	7.35	4.88	3.68	2.44	90	100	112	132*	160*		
	32.04	43.70	1785	8.17	5.43	4.08	2.71				132*			
+	26.72	52.40	1600	8.78	5.83	4.39	2.92				132*			
	26.41	53.00	1787	9.92	6.59	4.96	3.29	90	100	112	132	160*		
+	26.25	53.30	1608	8.98	5.97	4.49	2.98	90	100	112	132*	160*		
	22.38	62.60	1699	11.13	7.39	5.56	3.70	90	100	112	132	160*		
+	21.46	65.20	1686	11.52	7.65	5.76	3.83	90	100	112	132	160*		
	18.18	77.00	1800	14.51	9.64	7.26	4.82	90	100	112	132	160*		
+	15.19	92.20	1800	15.00	9.90	7.50	4.95	90	100	112	132	160		
	12.67	110.50	1750	15.00	9.90	7.50	4.95	90	100	112	132	160		
+	10.83	129.30	1700	15.00	9.90	7.50	4.95	90	100	112	132	160		
	9.23	151.70	1634	15.00	9.90	7.50	4.95	90	100	112	132	160		
+	8.33	168.10	1272	15.00	9.90	7.50	4.95	90	100	112	132	160		
	7.13	196.40	1202	15.00	9.90	7.50	4.95	90	100	112	132	160		
+	6.07	230.60	1200	15.00	9.90	7.50	4.95	90	100	112	132	160		
	5.44	257.40	1035	15.00	9.90	7.50	4.95				132	160		
+	5.00	280.00	1035	15.00	9.90	7.50	4.95				132	160		
	4.69	298.50	1035	15.00	9.90	7.50	4.95				132	160		

IEC - PAM bağlantısı yoktur - No IEC - PAM assembling on empty fields

63 IEC - PAM bağlantısı yapılır - IEC - PAM assembling available on numbered fields

80* IEC - PAM bağlantısı yapılacaksa P_{1max} değerleri aşılmamalıdır - Do not exceed the P_{1max} values indicated on fields with asterisk

W - IEC - PAM

Tip Type	İges	4-pol. 50 Hz 1400 rpm n ₂ [min ⁻¹]	M _{amax} f _B =1 4 - pol. [Nm]	Max. Giriş Gücü / Max. Input Power P _{1max} W f _B ≥ 1				IEC - PAM		DIN 42677' ye göre IEC Adaptöre Bağlanacak Motor Boyutu					
				4 - pol. 1400 rpm [kW]	6 - pol. 930 rpm [kW]	8 - pol. 700 rpm [kW]	12 - pol. 465 rpm [kW]	f _B ⇔	69 - 108	The motor size that will be connected to IEC adaptor according to DIN 42677.					
PD 52/12 PM 52/12  W  165 + IEC - PAM  W  164-165	2769.78	0.51	3000	0.20	0.13	0.10	0.07	63	71*						
	2215.83	0.63	3000	0.24	0.16	0.12	0.08	63	71*						
	1802.82	0.78	3000	0.28	0.19	0.14	0.09	63	71*						
	1333.49	1.00	3000	0.37	0.24	0.18	0.12		71*	80*	90*				
	1094.40	1.30	3000	0.44	0.29	0.22	0.15	63	71	80*	90*				
	861.34	1.60	3000	0.55	0.36	0.28	0.18	63	71	80*	90*	100*	112*		
	689.07	2.00	3000	0.68	0.45	0.34	0.22	63	71	80*	90*	100*	112*		
	549.54	2.50	3000	0.80	0.53	0.40	0.27	63	71	80	90*	100*	112*		
	448.15	3.10	3000	0.98	0.65	0.49	0.33	63	71	80	90*	100*	112*		
	338.40	4.10	3000	1.30	0.86	0.65	0.43	63	71	80	90*	100*	112*		
	272.80	5.10	3000	1.61	1.07	0.81	0.54	63	71	80	90	100*	112*		
	232.65	6.00	3000	1.89	1.26	0.95	0.63	63	71	80	90	100*	112*		
	174.49	8.00	3000	2.52	1.67	1.26	0.84	63	71	80	90	100*	112*		
	142.31	9.80	3000	3.00	1.98	1.50	0.99	63	71	80	90	100	112*		
	PD 53 PM 53  W  136 + IEC - PAM  W  136-137	1367.36	1.00	2700	0.29	0.19	0.14	0.10		80*	90*				
936.55		1.50	2700	0.42	0.28	0.21	0.14		80*	90*					
699.67		2.00	3200	0.67	0.45	0.34	0.22		80*	90*					
570.63		2.50	2800	0.72	0.48	0.36	0.24		80*	90*					
524.75		2.70	3200	0.89	0.59	0.45	0.30		80	90*					
427.97		3.30	3200	1.10	0.73	0.55	0.36		80	90*					
361.64		3.90	2800	1.14	0.75	0.57	0.38		80	90*					
331.54		4.20	3200	1.41	0.94	0.71	0.47	71	80	90*	100*	112*			
270.40		5.20	2700	1.46	0.97	0.73	0.49	71	80	90*	100*	112*			
248.66		5.60	3200	1.89	1.25	0.94	0.63	71	80	90	100*	112*			
202.80		6.90	3200	2.31	1.54	1.16	0.77	71	80	90	100*	112*			
171.36		8.20	2800	2.40	1.59	1.20	0.80	71	80	90	100*	112*			
153.85		9.10	3200	3.05	2.03	1.52	1.01	71	80	90	100	112*			
138.78		10.10	3200	3.38	2.25	1.69	1.12	71	80	90	100	112*			
117.27		11.90	2750	3.44	2.28	1.72	1.14	71	80	90	100	112*			
91.51	15.30	2900	4.65	3.09	2.32	1.54	71	80	90	100	112				
82.55	17.00	2795	4.96	3.30	2.48	1.65	71	80	90	100	112				

IEC - PAM bağlantısı yoktur - No IEC - PAM assembling on empty fields

63 IEC - PAM bağlantısı yapılır - IEC - PAM assembling available on numbered fields

80* IEC - PAM bağlantısı yapılacaksa P_{1max} değerleri aşılmamalıdır - Do not exceed the P_{1max} values indicated on fields with asterisk

W - IEC - PAM







Tip Type	İges	4-pol. 50 Hz 1400 rpm n ₂ [min ⁻¹]	M _{amax} f _B =1 4 - pol. [Nm]	Max. Giriş Gücü / Max. Input Power				IEC - PAM		DIN 42677' ye göre IEC Adaptöre Bağlanacak Motor Boyutu					
				P _{1max} W f _B ≥ 1				f _B ⇔ 69 - 108		The motor size that will be connected to IEC adapter according to DIN 42677.					
				4 - pol. 1400 rpm [kW]	6 - pol. 930 rpm [kW]	8 - pol. 700 rpm [kW]	12 - pol. 465 rpm [kW]								
PD 52 PM 52	134.05	10.40	2654	2.90	1.93	1.45	0.96	90	100*	112*					
	100.15	14.00	2241	3.28	2.18	1.64	1.09	90	100	112*					
W ↔ mm 136	91.82	15.20	2759	4.40	2.93	2.20	1.46		100	112	132*				
	81.68	17.10	1828	3.28	2.18	1.64	1.09	90	100	112*					
+	68.60	20.40	2970	6.35	4.22	3.17	2.11		100	112	132*				
	55.94	25.00	2600	6.81	4.53	3.41	2.26		100	112	132*				
IEC - PAM ↔ mm 136-137	55.55	25.20	2500	6.60	4.38	3.30	2.19	90	100	112	132*				
	51.45	27.20	3235	9.22	6.12	4.61	3.06				132*				
+	47.27	29.60	2400	7.44	4.94	3.72	2.47		100	112	132*				
	41.96	33.40	3200	11.18	7.43	5.59	3.71				132				
+	40.79	34.30	2500	8.98	5.97	4.49	2.98	90	100	112	132*	160*			
	35.45	39.50	2700	11.17	7.42	5.58	3.71				132				
+	33.41	41.90	2300	10.09	6.70	5.05	3.35	90	100	112	132	160*	180*		
	30.47	45.90	2900	13.95	9.27	6.98	4.63	90	100	112	132	160*	180*		
+	24.96	56.10	2900	17.03	11.31	8.52	5.66	90	100	112	132	160	180*		
	20.36	68.80	3100	22.00	14.52	11.00	7.26	90	100	112	132	160	180		
+	18.86	74.20	2600	20.21	13.42	10.10	6.71	90	100	112	132	160	180*		
	17.61	79.50	2750	22.00	14.52	11.00	7.26	90	100	112	132	160	180		
+	15.38	91.00	2600	22.00	14.52	11.00	7.26	90	100	112	132	160	180		
	13.00	107.70	2629	22.00	14.52	11.00	7.26	90	100	112	132	160	180		
+	10.73	130.50	2500	22.00	14.52	11.00	7.26		100	112	132	160	180		
	9.47	147.80	2300	22.00	14.52	11.00	7.26		100	112	132	160	180		
+	8.69	161.10	2360	22.00	14.52	11.00	7.26	90	100	112	132	160	180		
	7.17	195.30	2161	22.00	14.52	11.00	7.26		100	112	132	160	180		
+	6.33	221.20	2114	22.00	14.52	11.00	7.26		100	112	132	160	180		
	5.70	245.60	1800	22.00	14.52	11.00	7.26					160	180		
+	5.35	261.70	1750	22.00	14.52	11.00	7.26					160	180		
	5.02	278.90	1700	22.00	14.52	11.00	7.26					160	180		
+	4.32	324.10	1550	22.00	14.52	11.00	7.26					160	180		

IEC - PAM bağlantısı yoktur - No IEC - PAM assembling on empty fields

63 IEC - PAM bağlantısı yapılır - IEC - PAM assembling available on numbered fields

80* IEC - PAM bağlantısı yapılacaksa P_{1max} değerleri aşılmamalıdır - Do not exceed the P_{1max} values indicated on fields with asterisk

W - IEC - PAM

Tip Type	İges	4-pol. 50 Hz 1400 rpm n ₂ [min ⁻¹]	M _{amax} f _B =1 4 - pol. [Nm]	Max. Giriş Gücü / Max. Input Power P _{1max} W f _B ≥ 1				IEC - PAM		DIN 42677' ye göre IEC Adaptöre Bağlanacak Motor Boyutu							
				4 - pol. 1400 rpm [kW]	6 - pol. 930 rpm [kW]	8 - pol. 700 rpm [kW]	12 - pol. 465 rpm [kW]	f _B ⇔	69 - 108	The motor size that will be connected to IEC adapter according to DIN 42677.							
PD 63/22 PM 63/22  167 + IEC - PAM  166-167	4160.29	0.34	4780	0.21	0.14	0.10	0.07	71*	80*								
	3456.44	0.41	5400	0.27	0.18	0.13	0.09	71*	80*	90*							
	2738.15	0.51	4780	0.30	0.20	0.15	0.10	71*	80*	90*							
	2209.62	0.63	5400	0.40	0.26	0.20	0.13		80*	90*							
	1859.06	0.75	5400	0.47	0.31	0.23	0.15		80*	90*							
	1260.77	1.10	5400	0.67	0.44	0.33	0.22	71	80*	90*	100*	112*					
	1104.71	1.30	5400	0.76	0.50	0.38	0.25	71	80	90*	100*	112*					
	821.10	1.70	5400	0.96	0.64	0.48	0.32	71	80	90*	100*	112*					
	637.34	2.20	5400	1.24	0.83	0.62	0.41	71	80	90*	100*	112*					
	570.21	2.50	5400	1.39	0.92	0.69	0.46	71	80	90*	100*	112*					
	434.44	3.20	5400	1.82	1.21	0.91	0.61	71	80	90	100*	112*					
	349.07	4.00	5400	2.27	1.51	1.13	0.75	71	80	90	100*	112*					
	300.12	4.70	5400	2.64	1.75	1.32	0.88	71	80	90	100*	112*					
PD 63/32 PM 63/32  167 + IEC - PAM  166-167	223.50	6.30	4780	3.14	2.08	1.57	1.04	90	100	112*	132*						
	191.13	7.30	4780	3.67	2.44	1.83	1.22	90	100	112*	132*						
	158.90	8.80	4780	4.41	2.93	2.20	1.46	90	100	112	132*						
PD 63 PM 63  140 + IEC - PAM  140-141	552.15	2.50	5170	1.37	0.91	0.69	0.46	90*									
	445.80	3.10	4170	1.37	0.91	0.69	0.46	90*									
	393.43	3.60	5880	2.19	1.46	1.10	0.73	90	100*	112*							
	317.64	4.40	5640	2.60	1.73	1.30	0.86	90	100*	112*							
	267.94	5.20	5880	3.22	2.14	1.61	1.07		100	112*	132*						
	251.63	5.60	4480	2.61	1.73	1.30	0.87	90	100*	112*							
	225.83	6.20	4020	2.61	1.73	1.30	0.87	90	100*	112*							
	212.26	6.60	4670	3.23	2.14	1.61	1.07		100	112*	132*						
	171.37	8.20	5570	4.76	3.17	2.38	1.58		100	112	132*						
	160.11	8.70	5770	5.28	3.51	2.64	1.75	90	100	112	132*						
	126.84	11.00	4580	5.29	3.52	2.65	1.76	90	100	112	132*						
	114.79	12.20	5880	7.51	4.99	3.75	2.49	90	100	112	132*	160*					
	92.68	15.10	6000	9.49	6.30	4.75	3.15	90	100	112	132	160*					
	75.30	18.60	6000	11.68	7.76	5.84	3.88	90	100	112	132	160*					
	73.42	19.10	5570	11.10	7.39	5.56	3.69	90	100	112	132	160*					
	59.65	23.50	5500	13.52	8.98	6.76	4.49	90	100	112	132	160*					
	51.01	27.40	5080	14.60	9.70	7.30	4.85	90	100	112	132	160*					
	42.41	33.00	4550	15.73	10.45	7.86	5.22	90	100	112	132	160					
36.27	38.60	4550	18.39	12.22	9.20	6.11	90	100	112	132	160						
30.90	45.30	4550	21.59	14.34	10.79	7.17	90	100	112	132	160	180					
28.66	48.80	4600	22.00	14.52	11.00	7.26	90	100	112	132	160	180					
24.42	57.30	4690	22.00	14.52	11.00	7.26	90	100	112	132	160	180					

IEC - PAM bağlantısı yoktur - No IEC - PAM assembling on empty fields

63 IEC - PAM bağlantısı yapılır - IEC - PAM assembling available on numbered fields

80* IEC - PAM bağlantısı yapılacaksa P_{1max} değerleri aşılmamalıdır - Do not exceed the P_{1max} values indicated on fields with asterisk

W - IEC - PAM







Tip Type	İges	4-pol. 50 Hz 1400 rpm n ₂ [min ⁻¹]	M _{amax} f _B =1 4 - pol. [Nm]	Max. Giriş Gücü / Max. Input Power P _{1max} W f _B ≥ 1				IEC - PAM f _B ⇔ 69 - 108		DIN 42677' ye göre IEC Adaptöre Bağlanacak Motor Boyutu				
				4 - pol. 1400 rpm [kW]	6 - pol. 930 rpm [kW]	8 - pol. 700 rpm [kW]	12 - pol. 465 rpm [kW]			The motor size that will be connected to IEC adapter according to DIN 42677.				
PD 62 PM 62	80.26	17.40	4131	7.55	5.01	3.77	2.51	100	112	132*				
	65.45	21.40	3369	7.55	5.01	3.77	2.51	100	112	132*				
W mm 140 + IEC - PAM mm 140-141	61.05	22.90	4535	10.89	7.23	5.44	3.62			132	160*	180*		
	49.79	28.10	4040	11.89	7.90	5.95	3.95			132	160*	180*		
	39.44	35.50	3200	11.89	7.90	5.95	3.95			132	160*	180*		
	29.89	46.80	4537	22.25	14.78	11.13	7.39	100	112	132	160	180		
	26.02	53.80	4533	25.54	16.97	12.77	8.48	100	112	132	160	180		
	22.91	61.10	4535	29.02	19.28	14.51	9.64	100	112	132	160	180	200*	225*
	18.68	74.90	4427	34.74	23.08	17.37	11.54	100	112	132	160	180	200	225*
	14.80	94.60	4475	44.33	29.44	22.16	14.72	100	112	132	160	180	200	225*
	12.34	113.50	4389	45.00	29.70	22.50	14.85	100	112	132	160	180	200	225
	10.64	131.60	2026	27.91	18.54	13.96	9.27	100	112	132	160	180		
10.62	131.80	4314	45.00	29.70	22.50	14.85	100	112	132	160	180	200	225	
9.37	149.40	2754	43.09	28.62	21.54	14.31	100	112	132	160	180	200	225*	
7.81												200	225	
6.73												200	225	
5.99												200	225	
5.78	242.20	2334	45.00	29.70	22.50	14.85			132	160	180	200	225	
5.49	255.00	2291	45.00	29.70	22.50	14.85			132	160	180	200	225	
4.90	285.70	2156	45.00	29.70	22.50	14.85			132	160	180	200	225	
4.38	319.60	2034	45.00	29.70	22.50	14.85					180	200	225	

IEC - PAM bağlantısı yoktur - No IEC - PAM assembling on empty fields

63 IEC - PAM bağlantısı yapılır - IEC - PAM assembling available on numbered fields

80* IEC - PAM bağlantısı yapılacaksa P_{1max} değerleri aşılmamalıdır - Do not exceed the P_{1max} values indicated on fields with asterisk

W - IEC - PAM

Tip Type	İges	4-pol. 50 Hz 1400 rpm n ₂ [min ⁻¹]	M _{amax} f _B =1 4 - pol. [Nm]	Max. Giriş Gücü / Max. Input Power P _{1max} W f _B ≥ 1				IEC - PAM		DIN 42677' ye göre IEC Adaptöre Bağlanacak Motor Boyutu							
				4 - pol. 1400 rpm [kW]	6 - pol. 930 rpm [kW]	8 - pol. 700 rpm [kW]	12 - pol. 465 rpm [kW]	f _B ⇔	69 - 108	The motor size that will be connected to IEC adapter according to DIN 42677.							
PD 73/22 PM 73/22  + IEC - PAM 	5651.03	0.25	7080	0.22	0.15	0.11	0.07	71*	80*	90*							
	4889.70	0.29	7080	0.25	0.17	0.13	0.08	71*	80*	90*							
	3612.58	0.39	7080	0.33	0.22	0.16	0.11		80*	90*							
	2629.95	0.53	7080	0.43	0.29	0.22	0.14		80*	90*							
	2061.26	0.68	7080	0.54	0.36	0.27	0.18	71	80*	90*	100*	112*					
	1806.13	0.78	7080	0.61	0.41	0.31	0.20	71	80*	90*	100*	112*					
	1342.44	1.00	7080	0.77	0.51	0.39	0.26	71	80	90*	100*	112*					
	1042.00	1.30	7080	1.00	0.66	0.50	0.33	71	80	90*	100*	112*					
	932.25	1.50	7080	1.11	0.74	0.56	0.37	71	80	90*	100*	112*					
	710.29	2.00	7080	1.46	0.97	0.73	0.49	71	80	90*	100*	112*					
	570.70	2.50	7080	1.82	1.21	0.91	0.60	71	80	90	100*	112*					
	434.82	3.20	7080	2.39	1.59	1.19	0.79	71	80	90	100*	112*					
	376.24	3.70	7080	2.76	1.83	1.38	0.92	71	80	90	100*	112*					
	PD 73/32 PM 73/32  + IEC - PAM 	295.06	4.70	7060	3.51	2.33	1.75	1.17	90	100	112*	132*					
223.01		6.30	7060	4.64	3.08	2.32	1.54	90	100	112	132*						
PD 73 PM 73  + IEC - PAM 	338.37	4.10	7540	3.27	2.17	1.63	1.08	100	112*	132*							
	273.32	5.10	7540	4.04	2.69	2.02	1.34	100	112	132*							
	216.45	6.50	8300	5.62	3.73	2.81	1.87	100	112	132*							
	204.72	6.80	7540	5.40	3.59	2.70	1.79	100	112	132*							
	162.12	8.60	6270	5.67	3.77	2.83	1.88	100	112	132*							
	150.32	9.30	7540	7.35	4.88	3.68	2.44	100	112	132*							
	123.12	11.40	7540	8.98	5.96	4.49	2.98	100	112	132*	160*	180*					
	106.53	13.10	7540	10.38	6.89	5.19	3.45	100	112	132	160*	180*					
	93.05	15.00	7540	11.88	7.89	5.94	3.95	100	112	132	160*	180*	200*	225*			
	78.75	17.80	7420	13.81	9.18	6.91	4.59	100	112	132	160*	180*					
	68.14	20.50	7200	15.49	10.29	7.75	5.14	100	112	132	160	180*					
	59.52	23.50	7060	17.39	11.55	8.69	5.78	100	112	132	160	180*	200*	225*			
	53.42	26.20	7080	19.43	12.91	9.71	6.45	100	112	132	160	180*					
	46.66	30.00	7080	22.24	14.78	11.12	7.39	100	112	132	160	180	200*	225*			
	36.95	37.90	6620	26.26	17.45	13.13	8.72	100	112	132	160	180	200*	225*			
	30.49	45.90	6620	31.83	21.14	15.91	10.57	100	112	132	160	180	200	225*			
26.92	52.00	6620	36.05	23.95	18.03	11.97	100	112	132	160	180	200	225*				
23.47	59.70	6610	41.29	27.43	20.64	13.71	100	112	132	160	180	200	225*				

IEC - PAM bağlantısı yoktur - No IEC - PAM assembling on empty fields

63 IEC - PAM bağlantısı yapılır - IEC - PAM assembling available on numbered fields

80* IEC - PAM bağlantısı yapılacaksa P_{1max} değerleri aşılmamalıdır - Do not exceed the P_{1max} values indicated on fields with asterisk

W - IEC - PAM









Tip Type	İges	4-pol. 50 Hz 1400 rpm n ₂ [min ⁻¹]	M _{amax} f _B =1 4 - pol. [Nm]	Max. Giriş Gücü / Max. Input Power				IEC - PAM					DIN 42677' ye göre IEC Adaptöre Bağlanacak Motor Boyutu				
				P _{1max} W f _B ≥ 1				f _B ⇔ 69 - 108					The motor size that will be connected to IEC adapter according to DIN 42677.				
				4 - pol. 1400 rpm [kW]	6 - pol. 930 rpm [kW]	8 - pol. 700 rpm [kW]	12 - pol. 465 rpm [kW]										
PD 72 PM 72	69.80	20.10	5804	12.19	8.10	6.09	4.05	132	160*	180*							
	56.90	24.60	5534	14.26	9.47	7.13	4.74	132	160*	180*							
W ↔ 144	45.66	30.70	5809	18.65	12.39	9.33	6.19		160	180*	200*						
	45.06	31.10	4382	14.26	9.47	7.13	4.74	132	160*	180*							
+	37.22	37.60	6473	25.49	16.94	12.75	8.47		160	180	200*						
	34.69	40.40	5804	24.53	16.29	12.26	8.15	132	160	180							
IEC - PAM ↔ 144-145	26.89	52.10	5807	31.66	21.03	15.83	10.52	132	160	180	200	225*					
	22.90	61.10	5802	37.14	24.67	18.57	12.34	132	160	180	200	225*					
	19.96	70.10	5810	42.67	28.35	21.34	14.17	132	160	180	200	225*					
	16.27	86.00	6469	45.00	29.70	22.50	14.85	132	160	180	200	225					
	12.89	108.60	5864	45.00	29.70	22.50	14.85	132	160	180	200	225					
	11.18	125.20	6221	45.00	29.70	22.50	14.85	132	160	180	200	225					
	9.91	141.30	4273	45.00	29.70	22.50	14.85	132	160	180	200	225					
	9.46	148.00	6263	45.00	29.70	22.50	14.85	132	160	180	200	225					
	8.64	162.00	4222	45.00	29.70	22.50	14.85	132	160	180	200	225					
	7.50	186.70	4507	45.00	29.70	22.50	14.85	132	160	180	200	225					
	6.34	220.80	4450	45.00	29.70	22.50	14.85	132	160	180	200	225					
	5.96	234.90	4322	45.00	29.70	22.50	14.85					225					
	5.30	264.20	4065	45.00	29.70	22.50	14.85	132	160	180	200	225					
	5.03	278.30	3929	45.00	29.70	22.50	14.85					225					
	4.26	328.60	3619	45.00	29.70	22.50	14.85	132	160	180	200	225					

IEC - PAM bağlantısı yoktur - No IEC - PAM assembling on empty fields

63 IEC - PAM bağlantısı yapılır - IEC - PAM assembling available on numbered fields

80* IEC - PAM bağlantısı yapılacaksa P_{1max} değerleri aşılmamalıdır - Do not exceed the P_{1max} values indicated on fields with asterisk

W - IEC - PAM

Tip Type	İges	4-pol. 50 Hz 1400 rpm n ₂ [min ⁻¹]	M _{amax} f _B =1 4 - pol. [Nm]	Max. Giriş Gücü / Max. Input Power P _{1max} W f _B ≥ 1				IEC - PAM		DIN 42677' ye göre IEC Adaptöre Bağlanacak Motor Boyutu							
				4 - pol. 1400 rpm [kW]	6 - pol. 930 rpm [kW]	8 - pol. 700 rpm [kW]	12 - pol. 465 rpm [kW]	f _B ⇔	69 - 108	The motor size that will be connected to IEC adapter according to DIN 42677.							
PD 83/32 PM 83/32  W  167 + IEC - PAM  166-167	6601.35	0.21	12100	0.31	0.20	0.15	0.10	71*	80*	90*							
	5504.36	0.25	12100	0.36	0.24	0.18	0.12	71*	80*	90*							
	4202.93	0.33	12100	0.46	0.31	0.23	0.15		80*	90*							
	3519.07	0.40	12100	0.54	0.36	0.27	0.18		80*	90*							
	2996.11	0.47	12100	0.63	0.42	0.32	0.21		80*	90*							
	2408.64	0.58	12100	0.78	0.51	0.39	0.26		80	90*	100*	112*					
	1692.65	0.83	12100	1.05	0.70	0.52	0.35	71	80	90*	100*	112*					
	1362.94	1.00	12100	1.30	0.86	0.65	0.43	71	80	90*	100*	112*					
	1061.83	1.30	12100	1.67	1.11	0.84	0.55	71	80	90	100*	112*	132*				
	889.06	1.60	12100	2.00	1.33	1.00	0.66	71	80	90	100*	112*	132*				
716.55	2.00	12100	2.48	1.64	1.24	0.82			90	100*	112*	132*					
610.07	2.30	12100	2.91	1.93	1.45	0.97			90	100*	112*	132*					
PD 83/42 PM 83/42  W  169 + IEC - PAM  168-169	550.29	2.50	12100	3.22	2.14	1.61	1.07	90	100	112*	132*	160*					
	468.82	3.00	12100	3.78	2.51	1.89	1.26	90	100	112*	132*	160*					
	346.82	4.00	12100	5.11	3.40	2.56	1.70	90	100	112	132*	160*					
	295.48	4.70	12100	6.00	3.99	3.00	1.99	90	100	112	132*	160*					
	223.71	6.30	12100	7.93	5.27	3.96	2.63	90	100	112	132*	160*					
	186.54	7.50	12100	9.20	6.07	4.60	3.04	90	100	112	132	160*					
PD 83 PM 83  W  148 + IEC - PAM  148-149	386.39	3.60	12700	4.82	3.20	2.41	1.60	100	112	132*							
	318.11	4.40	13000	5.99	3.98	3.00	1.99	100	112	132*							
	293.92	4.80	12700	6.33	4.21	3.17	2.10			132*	160*	180*					
	241.98	5.80	13100	7.94	5.27	3.97	2.64			132*	160*	180*					
	200.83	7.00	10800	7.88	5.24	3.94	2.62	100	112	132*							
	185.56	7.50	12680	10.02	6.65	5.01	3.33			132	160*	180*					
	152.77	9.20	13200	12.67	8.41	6.33	4.21			132	160*	180*					
	143.91	9.70	12500	12.73	8.46	6.37	4.23	100	112	132	160*	180*					
	125.27	11.20	12190	14.27	9.48	7.13	4.74	100	112	132	160*	180*					
	118.48	11.80	12450	15.40	10.23	7.70	5.12	100	112	132	160	180*					
	103.13	13.60	12100	17.20	11.43	8.60	5.71	100	112	132	160	180*					
	90.79	15.40	12100	19.54	12.98	9.77	6.49	100	112	132	160	180*	200*	225*			
	75.70	18.50	12100	23.43	15.57	11.72	7.78	100	112	132	160	180	200*	225*			
	65.16	21.50	11300	25.42	16.89	12.71	8.44	100	112	132	160	180	200*	225*			
	57.32	24.40	12100	30.95	20.56	15.47	10.28	100	112	132	160	180	200	225*			
	47.79	29.30	12100	37.12	24.66	18.56	12.33	100	112	132	160	180	200	225*			
43.52	32.20	10600	35.71	23.72	17.85	11.86	100	112	132	160	180	200	225*				
35.83	39.10	12080	45.00	29.70	22.50	14.85	100	112	132	160	180	200	225				
30.84	45.40	12090	45.00	29.70	22.50	14.85	100	112	132	160	180	200	225				

IEC - PAM bağlantısı yoktur - No IEC - PAM assembling on empty fields

63 IEC - PAM bağlantısı yapılır - IEC - PAM assembling available on numbered fields

80* IEC - PAM bağlantısı yapılacaksa P_{1max} değerleri aşılmamalıdır - Do not exceed the P_{1max} values indicated on fields with asterisk

W - IEC - PAM













Tip Type	İges	4-pol. 50 Hz 1400 rpm n ₂ [min ⁻¹]	M _{amax} f _B =1 4 - pol. [Nm]	Max. Giriş Gücü / Max. Input Power				IEC - PAM								
				P _{1max} W f _B ≥ 1				f _B ⇔ 69 - 108								
				4 - pol. 1400 rpm [kW]	6 - pol. 930 rpm [kW]	8 - pol. 700 rpm [kW]	12 - pol. 465 rpm [kW]	DIN 42677' ye göre IEC Adaptöre Bağlanacak Motor Boyutu The motor size that will be connected to IEC adapter according to DIN 42677.								
PD 82 PM 82	72.17	19.40	7875	16.00	10.63	8.00	5.31	132	160	180*						
	59.41	23.60	6483	16.00	10.63	8.00	5.31	132	160	180*						
W mm 148	47.51	29.50	10613	32.75	21.75	16.37	10.88		160	180	200					
	39.18	35.70	10615	39.72	26.38	19.86	13.19				200	225*				
+	39.12	35.80	9342	35.01	23.26	17.50	11.63		160	180	200					
	32.25	43.40	10346	47.03	31.24	23.51	15.62				200	225				
IEC - PAM mm 148-149	28.35	49.40	9998	51.70	34.34	25.85	17.17	132	160	180	200	225				
	24.51	57.10	10603	63.42	42.13	31.71	21.06	132	160	180	200	225	250			
	17.41	80.40	10618	73.63	48.91	36.82	24.46	132	160	180	200	225	250	280*		
	15.19	92.20	9480	75.00	49.50	37.50	24.75	132	160	180	200	225	250	280*		
	12.99	107.80	10294	75.00	49.50	37.50	24.75	132	160	180	200	225	250	280*		
	10.88	128.70	10290	75.00	49.50	37.50	24.75	132	160	180	200	225	250	280*		
	9.67	144.80	6521	75.00	49.50	37.50	24.75	132	160	180	200	225	250	280*		
	8.27	169.30	7296	75.00	49.50	37.50	24.75	132	160	180	200	225	250	280*		
	6.93	202.00	6786	75.00	49.50	37.50	24.75	132	160	180	200	225	250	280*		
	4.52	309.70	4890	75.00	49.50	37.50	24.75	132	160	180	200	225	250	280*		

IEC - PAM bağlantısı yoktur - No IEC - PAM assembling on empty fields

63 IEC - PAM bağlantısı yapılır - IEC - PAM assembling available on numbered fields

80* IEC - PAM bağlantısı yapılacaksa P_{1max} değerleri aşılmamalıdır - Do not exceed the P_{1max} values indicated on fields with asterisk

W - IEC - PAM









Tip Type	İges	4-pol. 50 Hz 1400 rpm n ₂ [min ⁻¹]	M _{amax} f _B =1 4 - pol. [Nm]	Max. Giriş Gücü / Max. Input Power P _{1max} W f _B ≥ 1				IEC - PAM		DIN 42677' ye göre IEC Adaptöre Bağlanacak Motor Boyutu								
				4 - pol. 1400 rpm [kW]	6 - pol. 930 rpm [kW]	8 - pol. 700 rpm [kW]	12 - pol. 465 rpm [kW]	f _B ⇔	69 - 108	The motor size that will be connected to IEC adapter according to DIN 42677.								
PD 93/42 PM 93/42   + IEC - PAM  168-169	4158.29	0.34	24000	0.85	0.56	0.42	0.28		100*	112*	132*							
	2433.68	0.58	24000	1.45	0.96	0.72	0.48	90*	100*	112*								
	2202.85	0.64	24000	1.60	1.06	0.80	0.53	90	100*	112*								
	1744.83	0.80	24000	2.02	1.34	1.01	0.67	90	100*	112*	132*	160*						
	1417.68	0.99	24000	2.48	1.65	1.24	0.82	90	100*	112*	132*	160*						
	1177.36	1.20	24000	2.99	1.99	1.49	0.99	90	100	112*	132*	160*						
	885.67	1.60	24000	3.97	2.64	1.99	1.32	90	100	112	132*	160*						
	715.36	2.00	24000	4.92	3.27	2.46	1.63	90	100	112	132*	160*						
	618.83	2.30	24000	5.69	3.78	2.84	1.89	90	100	112	132*	160*						
	450.86	3.10	24000	7.80	5.18	3.90	2.59	90	100	112	132*	160*						
PD 93/52 PM 93/52   169 + IEC - PAM  168-169	410.49	3.40	24000	8.57	5.69	4.29	2.85	100	112	132*	160*	180*						
	294.19	4.80	24000	11.96	7.94	5.98	3.97	100	112	132	160*	180*						
	233.30	6.00	24000	15.08	10.02	7.54	5.01				160	180*						
	200.50	7.00	24000	17.55	11.66	8.77	5.83				160	180*						
PD 93 PM 93   152 + IEC - PAM  152-153	352.16	4.00	25400	10.57	7.02	5.29	3.51	132	160*	180*								
	290.94	4.80	24000	12.09	8.03	6.05	4.02	132	160*	180*								
	204.66	6.80	22000	15.76	10.47	7.88	5.23	132	160	180*								
	175.03	8.00	25400	21.27	14.13	10.64	7.07	132	160	180*								
	144.60	9.70	24000	24.33	16.16	12.17	8.08	132	160	180								
	135.66	10.30	25400	27.45	18.23	13.72	9.12	132	160	180	200*	225*						
	115.51	12.10	25400	32.24	21.41	16.12	10.71	132	160	180	200	225*	250*					
	100.70	13.90	25400	36.98	24.56	18.49	12.28	132	160	180	200	225*	250*	280*				
	83.19	16.80	24000	42.29	28.09	21.15	14.05	132	160	180	200	225*	250*	280*				
	72.17	19.40	24000	48.75	32.38	24.38	16.19	132	160	180	200	225	250*	280*				
	65.13	21.50	24260	54.61	36.27	27.30	18.14	132	160	180	200	225						
	55.46	25.20	24000	63.44	42.14	31.72	21.07	132	160	180	200	225	250					
	48.35	29.00	24000	72.77	48.34	36.38	24.17	132	160	180	200	225	250	280*				
	41.94	33.40	24000	75.00	49.50	37.50	24.75	132	160	180	200	225	250	280*				
	35.49	39.40	24000	75.00	49.50	37.50	24.75	132	160	180	200	225	250	280*				
PD 92 PM 92   152 + IEC - PAM  152-153	34.36	40.70	16250	69.33	46.06	34.67	23.03	180	200	225	250							
	30.79	45.50	17930	85.37	56.71	42.68	28.35	180	200	225	250	280*						
	26.85	52.10	17200	93.91	62.38	46.95	31.19	180	200	225	250	280	315*					
	23.17	60.40	16426	103.93	69.04	51.96	34.52	180	200	225	250	280	315*					
	20.09	69.70	15926	116.21	77.20	58.11	38.60	180	200	225	250	280	315*					
	17.34	80.70	15492	130.97	87.00	65.49	43.50	180	200	225	250	280	315*					
	14.69	95.30	14715	146.85	97.55	73.42	48.77	180	200	225	250	280	315*					
	12.04	116.30	13808	160.00	105.60	80.00	52.80	180	200	225	250	280	315*					
	10.21	137.10	10792	154.95	102.93	77.48	51.47	180	200	225	250	280	315*					
	8.65	161.80	11160	160.00	105.60	80.00	52.80	180	200	225	250	280	315*					
	7.09	197.50	10116	160.00	105.60	80.00	52.80	180	200	225	250	280	315*					
	5.78	242.20	8825	160.00	105.60	80.00	52.80	180	200	255	250	280	315*					
	5.36	261.20	8336	160.00	105.60	80.00	52.80				250	280	315*					

IEC - PAM bağlantısı yoktur - No IEC - PAM assembling on empty fields

63 IEC - PAM bağlantısı yapılır - IEC - PAM assembling available on numbered fields

80* IEC - PAM bağlantısı yapılacaksa P_{1max} değerleri aşılmamalıdır - Do not exceed the P_{1max} values indicated on fields with asterisk

W - IEC - PAM













Tip Type	İges	4-pol. 50 Hz 1400 rpm n ₂ [min ⁻¹]	M _{amax} f _B =1 4 - pol. [Nm]	Max. Giriş Gücü / Max. Input Power				IEC - PAM		DIN 42677' ye göre IEC Adaptöre Bağlanacak Motor Boyutu							
				P _{1max} W f _B ≥ 1				f _B ⇔ 69 - 108		The motor size that will be connected to IEC adapter according to DIN 42677.							
				4 - pol. 1400 rpm [kW]	6 - pol. 930 rpm [kW]	8 - pol. 700 rpm [kW]	12 - pol. 465 rpm [kW]										
PD 103/52 PM 103/52  W  169 + IEC - PAM  168-169	4677.24	0.30	35000	1.10	0.73	0.55	0.36	90*	100*	112*							
	3520.13	0.40	35000	1.46	0.97	0.73	0.48		100*	112*	132*						
	2796.57	0.50	35000	1.83	1.22	0.92	0.61		100*	112*	132*						
	2402.69	0.58	35000	2.14	1.42	1.07	0.71				132*						
	1887.83	0.74	35000	2.72	1.81	1.36	0.90				132*						
	1416.90	0.99	35000	3.62	2.41	1.81	1.20		90	100	112*	132*	160*	180*			
	1165.61	1.20	35000	4.40	2.92	2.20	1.46		90	100	112	132*	160*	180*			
	915.84	1.50	35000	5.60	3.72	2.80	1.86		90	100	112	132*	160*	180*			
	692.20	2.00	35000	7.41	4.92	3.71	2.46		90	100	112	132*	160*	180*			
	578.09	2.40	35000	8.88	5.90	4.44	2.95		90	100	112	132*	160*	180*			
	476.93	2.90	35000	10.76	7.15	5.38	3.57			100	112	132	160*	180*			
	366.18	3.80	35000	14.01	9.31	7.01	4.65		90	100	112	132	160*	180*			
	302.10	4.60	35000	16.98	11.28	8.49	5.64			100	112	132	160	180*			
	PD 103 PM 103  W  156 + IEC - PAM  156-157	357.40	3.90	35460	14.54	9.66	7.27	4.83	160	180*							
332.64		4.20	37000	16.31	10.83	8.15	5.42	160	180*								
282.85		4.90	33000	17.10	11.36	8.55	5.68	160	180*								
263.25		5.30	33000	18.38	12.21	9.19	6.10	160	180*								
180.68		7.70	35000	28.40	18.86	14.20	9.43	160	180								
168.16		8.30	35000	30.51	20.27	15.26	10.13	160	180								
140.41		10.00	35480	37.04	24.61	18.52	12.30	160	180	200	225*						
104.71		13.40	35300	49.42	32.83	24.71	16.41	160	180	200	225	250*	280*				
91.35		15.30	35380	56.78	37.72	28.39	18.86	160	180	200	225	250	280*	315*			
72.71		19.30	37200	75.00	49.82	37.50	24.91	160	180	200	225	250	280*	315*			
65.44		21.40	35100	78.63	52.23	39.32	26.12	160	180	200	225	250	280*	315*			
56.76		24.70	35000	90.40	60.05	45.20	30.02	160	180	200	225	250	280	315*			
47.95		29.20	35000	107.01	71.08	53.50	35.54	160	180	200	225	250	280	315*			
41.00		34.10	35000	125.14	83.13	62.57	41.57	160	180	200	225	250	280	315*			
34.35		40.80	35000	149.37	99.22	74.69	49.61	160	180	200	225	250	280	315*			
29.79		47.00	35000	160.00	105.60	80.00	52.80	160	180	200	225	250	280	315*			
27.18		51.50	33000	160.00	105.60	80.00	52.80	160	180	200	225	250	280	315*			
23.58		59.40	33000	160.00	105.60	80.00	52.80	160	180	200	225	250	280	315*			
21.00		66.70	33000	160.00	105.60	80.00	52.80	160	180	200	225	250	280	315*			
PD 102 PM 102  W  156 + IEC - PAM  156-157	18.24	76.80	32000	200.00	132.00	100.00	66.00	250	280	315							
	15.19	92.20	32000	200.00	132.00	100.00	66.00	250	280	315							
	13.50	103.70	32000	200.00	132.00	100.00	66.00	250	280	315							
	11.63	120.40	32000	200.00	132.00	100.00	66.00	250	280	315							
	10.42	134.40	32000	200.00	132.00	100.00	66.00	250	280	315							
	9.20	152.20	30000	200.00	132.00	100.00	66.00	250	280	315							
	8.24	169.90	30000	200.00	132.00	100.00	66.00	250	280	315							
	7.58	184.70	19000	200.00	132.00	100.00	66.00	250	280	315							
	6.74	207.70	19000	200.00	132.00	100.00	66.00	250	280	315							
	5.80	241.40	19000	200.00	132.00	100.00	66.00	250	280	315							
5.20	269.20	19000	200.00	132.00	100.00	66.00	250	280	315								

IEC - PAM bağlantısı yoktur - No IEC - PAM assembling on empty fields

63 IEC - PAM bağlantısı yapılır - IEC - PAM assembling available on numbered fields

80* IEC - PAM bağlantısı yapılacaksa P_{1max} değerleri aşılmamalıdır - Do not exceed the P_{1max} values indicated on fields with asterisk

W - IEC - PAM





Tip Type	İges	4-pol. 50 Hz 1400 rpm n ₂ [min ⁻¹]	M _{amax} f _B =1 4 - pol. [Nm]	Max. Giriş Gücü / Max. Input Power P _{1max} W f _B ≥ 1				IEC - PAM		DIN 42677' ye göre IEC Adaptöre Bağlanacak Motor Boyutu						
				4 - pol. 1400 rpm [kW]	6 - pol. 930 rpm [kW]	8 - pol. 700 rpm [kW]	12 - pol. 465 rpm [kW]	f _B ⇔	69 - 108	The motor size that will be connected to IEC adapter according to DIN 42677.						
PD 113/52 PM 113/52 W   169 + IEC - PAM   168-171	4001.34	0.35	60000	2.20	1.46	1.10	0.73	90	100*	112*						
	3722.96	0.38	60000	2.36	1.57	1.18	0.78	90	100*	112*	132*	160*	180*			
	3062.69	0.46	60000	2.87	1.91	1.44	0.95	90	100*	112*	132*	160*	180*			
	2328.41	0.60	60000	3.78	2.51	1.89	1.25	90	100	112*	132*	160*	180*			
	1829.47	0.77	60000	4.81	3.19	2.40	1.60	90	100	112	132*	160*	180*			
	1382.74	1.00	60000	6.36	4.23	3.18	2.11	90	100	112	132*	160*	180*			
	1154.79	1.20	60000	7.62	5.06	3.81	2.53	90	100	112	132*	160*	180*			
	962.15	1.50	60000	9.14	6.07	4.57	3.04	90	100	112	132	160*	180*			
	731.47	1.90	60000	12.02	7.99	6.01	3.99	90	100	112	132	160*	180*			
	603.47	2.30	60000	14.58	9.68	7.29	4.84		100	112	132	160*	180*			
	479.85	2.90	60000	18.33	12.18	9.17	6.09					160	180*			
	363.21	3.90	50000	20.18	13.41	10.09	6.70					160	180*			
312.23	4.50	50000	22.00	14.52	11.00	7.26					160	180				
PD 113 PM 113 W   160 + IEC - PAM   160-161	224.76	6.20	69000	45.00	29.90	22.50	14.95	160	180							
	171.96	8.10	69000	58.82	39.08	29.41	19.54	160	180	200	225	250	280*			
	152.87	9.20	69000	66.17	43.95	33.08	21.98	160	180	200	225	250	280*	315*		
	130.73	10.70	69000	77.37	51.40	38.69	25.70	160	180	200	225	250	280*	315*		
	112.38	12.50	69000	90.01	59.79	45.00	29.90	160	180	200	225	250	280*	315*		
	92.07	15.20	65400	104.13	69.17	52.07	34.59	160	180	200	225	250	280	315*		
	77.01	18.20	62150	118.31	78.59	59.15	39.30	160	180	200	225	250	280	315*		
	63.44	22.10	60000	138.65	92.10	69.32	46.05	160	180	200	225	250	280	315*		
	54.26	25.80	60000	162.10	107.68	81.05	53.84	160	180	200	225	250	280	315*		
	46.64	30.00	60000	188.59	125.28	94.29	62.64	160	180	200	225	250	280	315*		
	38.21	36.60	60000	200.00	132.00	100.00	66.00	160	180	200	225	250	280	315		
	31.96	43.80	60000	200.00	132.00	100.00	66.00	160	180	200	225	250	280	315		
PD 112 PM 112 W   160 + IEC - PAM   160-161	34.85	40.20	42000	176.67	117.36	88.34	58.68	250	280	315*						
	29.92	46.80	42000	200.00	132.00	100.00	66.00	250	280	315						
	25.47	55.00	42000	200.00	132.00	100.00	66.00	250	280	315						
	21.42	65.40	42000	200.00	132.00	100.00	66.00	250	280	315						
	18.27	76.60	42000	200.00	132.00	100.00	66.00	250	280	315						
	16.33	85.70	42000	200.00	132.00	100.00	66.00	250	280	315						
	14.04	99.70	26600	200.00	132.00	100.00	66.00	250	280	315						
	11.96	117.10	26300	200.00	132.00	100.00	66.00	250	280	315						
	10.05	139.30	26000	200.00	132.00	100.00	66.00	250	280	315						
	8.58	163.20	24800	200.00	132.00	100.00	66.00	250	280	315						
	7.67	182.50	24000	200.00	132.00	100.00	66.00	250	280	315						

IEC - PAM bağlantısı yoktur - No IEC - PAM assembling on empty fields

63 IEC - PAM bağlantısı yapılır - IEC - PAM assembling available on numbered fields

80* IEC - PAM bağlantısı yapılacaksa P_{1max} değerleri aşılmamalıdır - Do not exceed the P_{1max} values indicated on fields with asterisk

W - IEC - PAM

Tip Type	İges	4-pol. 50 Hz 1400 rpm n ₂ [min ⁻¹]	M _{amax} f _B =1 4 - pol. [Nm]	Max. Giriş Gücü / Max. Input Power P _{1max} W f _B ≥ 1				IEC - PAM f _B ⇔ 69 - 108		DIN 42677* ye göre IEC Adaptöre Bağlanacak Motor Boyutu The motor size that will be connected to IEC adapter according to DIN 42677.							
				4 - pol. 1400 rpm [kW]	6 - pol. 930 rpm [kW]	8 - pol. 700 rpm [kW]	12 - pol. 465 rpm [kW]										
PD 123	201.75	6.90	90000	65.40	43.44	32.70	21.72	160	180	200	225						
PM 123	154.35	9.10	90000	85.48	56.78	42.74	28.39	160	180	200	225	250	280*				
 W 163	137.22	10.20	90000	96.15	63.87	48.08	31.94	160	180	200	225	250	280	315*			
 + 163	117.35	11.90	90000	112.43	74.69	56.22	37.34	160	180	200	225	250	280	315*			
IEC - PAM	100.88	13.90	90000	130.79	86.88	65.39	43.44	160	180	200	225	250	280	315*			
 W 163	82.65	16.90	90000	159.60	106.04	79.80	53.02	160	180	200	225	250	280	315*			
 W 163	69.12	20.30	90000	190.88	126.80	95.44	63.40	160	180	200	225	250	280	315*			

IEC - PAM bağlantısı yoktur - No IEC - PAM assembling on empty fields

63 IEC - PAM bağlantısı yapılır - IEC - PAM assembling available on numbered fields

80* IEC - PAM bağlantısı yapılacaksa P_{1max} değerleri aşılmamalıdır - Do not exceed the P_{1max} values indicated on fields with asterisk

TR

GENEL PARÇA LİSTESİ

EN

GENERAL PART LIST

PD/PM A02 - PD/PM 12...52

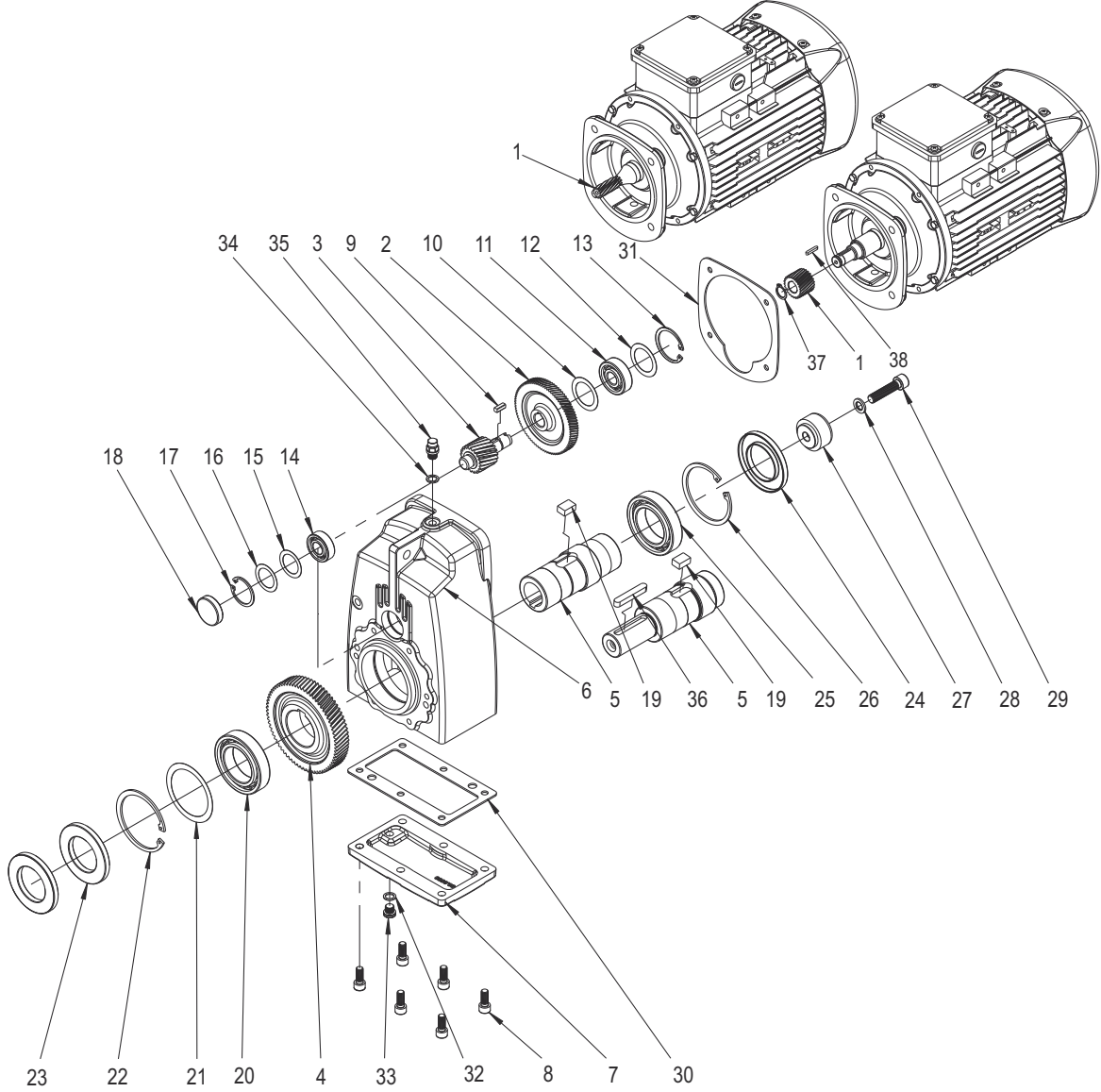

1. Z1 Dişlisi
2. Z2 Dişlisi
3. Z3 Dişlisi
4. Z4 Dişlisi
5. Çıkış Şaftı
6. Gövde
7. Gövde Kapağı
8. Alyan Başlı Civata
9. Kama
10. Rondela
11. Rulman
12. Layner
13. Segman
14. Rulman
15. Rondela
16. Layner
17. Segman
18. Yağ Kapağı
19. Kama

20. Rulman
21. Layner
22. Segman
23. Şaft Keçesi
24. Şaft Keçesi
25. Rulman
26. Segman
27. Çektirme Rondelası
28. Yaylı Rondela
29. Alyan Başlı Civata
30. Conta
31. Conta
32. Conta
33. Boşaltma Tapası
34. Conta
35. Havalandırma Tapası
36. Kama
37. Segman
38. Kama

1. Pinion
2. Driven Gear
3. Pinion
4. Driven Gear
5. Output Shaft
6. Gear Case
7. Gear Case Cover
8. Socket Head Screw
9. Key
10. Supporting Disc
11. Bearing
12. Shim
13. Circlip
14. Bearing
15. Supporting Disc
16. Shim
17. Circlip
18. Locking Cap
19. Key

20. Bearing
21. Shim
22. Circlip
23. Shaft Seal
24. Shaft Seal
25. Bearing
26. Circlip
27. Fixing Element
28. Spring Washer
29. Socket Head Screw
30. Gasket
31. Gasket
32. Gasket
33. Drain Plug
34. Gasket
35. Vent Plug
36. Key
37. Circlip
38. Key

PD/PM B02
PD/PM 62...112

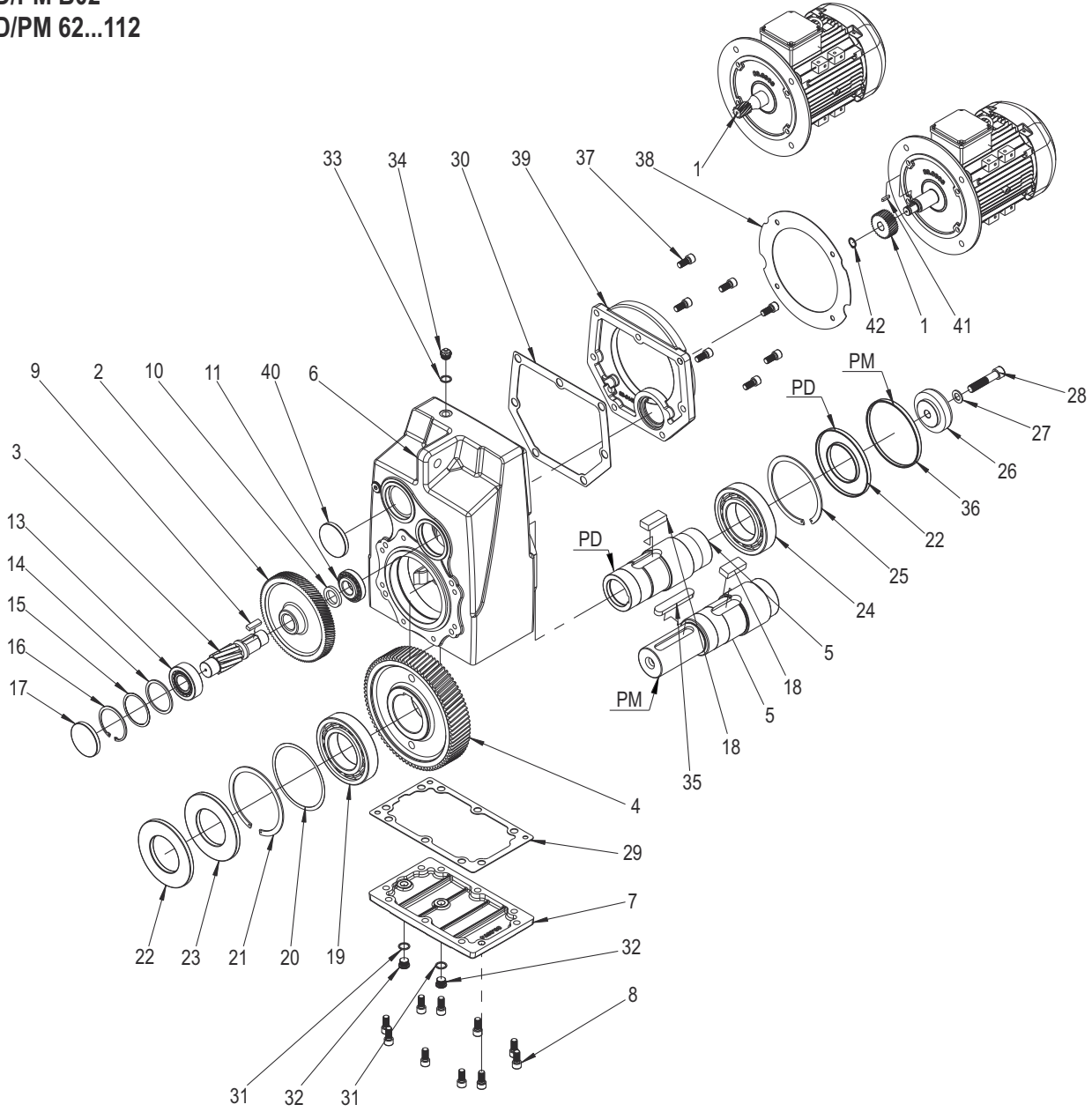

1. Z1 Dişlisi
2. Z2 Dişlisi
3. Z3 Dişlisi
4. Z4 Dişlisi
5. Çıkış Şaftı
6. Gövde
7. Gövde Kapağı
8. Alyan Başlı Civata
9. Kama
10. Rondela
11. Rulman
13. Rulman
14. Rondela
15. Layner
16. Segman
17. Yağ Kapağı
18. Kama
19. Rulman
20. Layner
21. Segman
22. Şaft Keçesi

23. Şaft Keçesi
24. Rulman
25. Segman
26. Çektirme Rondelası
27. Yayı Rondela
28. Alyan Başlı Civata
29. Conta
30. Conta
31. Conta
32. Boşaltma Tapası
33. Conta
34. Havalandırma Tapası
35. Kama
36. Yağ Kapağı
37. Alyan Başlı Civata
38. Conta
39. Ara Bağlantı Flanşı
40. Yağ Kapağı
41. Kama
42. Segman

1. Pinion
2. Driven Gear
3. Pinion
4. Driven Gear
5. Output Shaft
6. Gear Case
7. Gear Case Cover
8. Socket Head Screw
9. Key
10. Supporting Disc
11. Bearing
13. Bearing
14. Supporting Disc
15. Shim
16. Circlip
17. Locking Cap
18. Key
19. Bearing
20. Shim
21. Circlip
22. Shaft Seal

23. Shaft Seal
24. Bearing
25. Circlip
26. Fixing Element
27. Spring Washer
28. Socket Head Screw
29. Gasket
30. Gasket
31. Gasket
32. Drain Plug
33. Gasket
34. Vent Plug
35. Key
36. Locking Cap
37. Socket Head Screw
38. Gasket
39. Intermediate Flange
40. Locking Cap
41. Key
42. Circlip

TR

GENEL PARÇA LİSTESİ

PD/PM C13
PD/PM 63...113

EN

GENERAL PART LIST

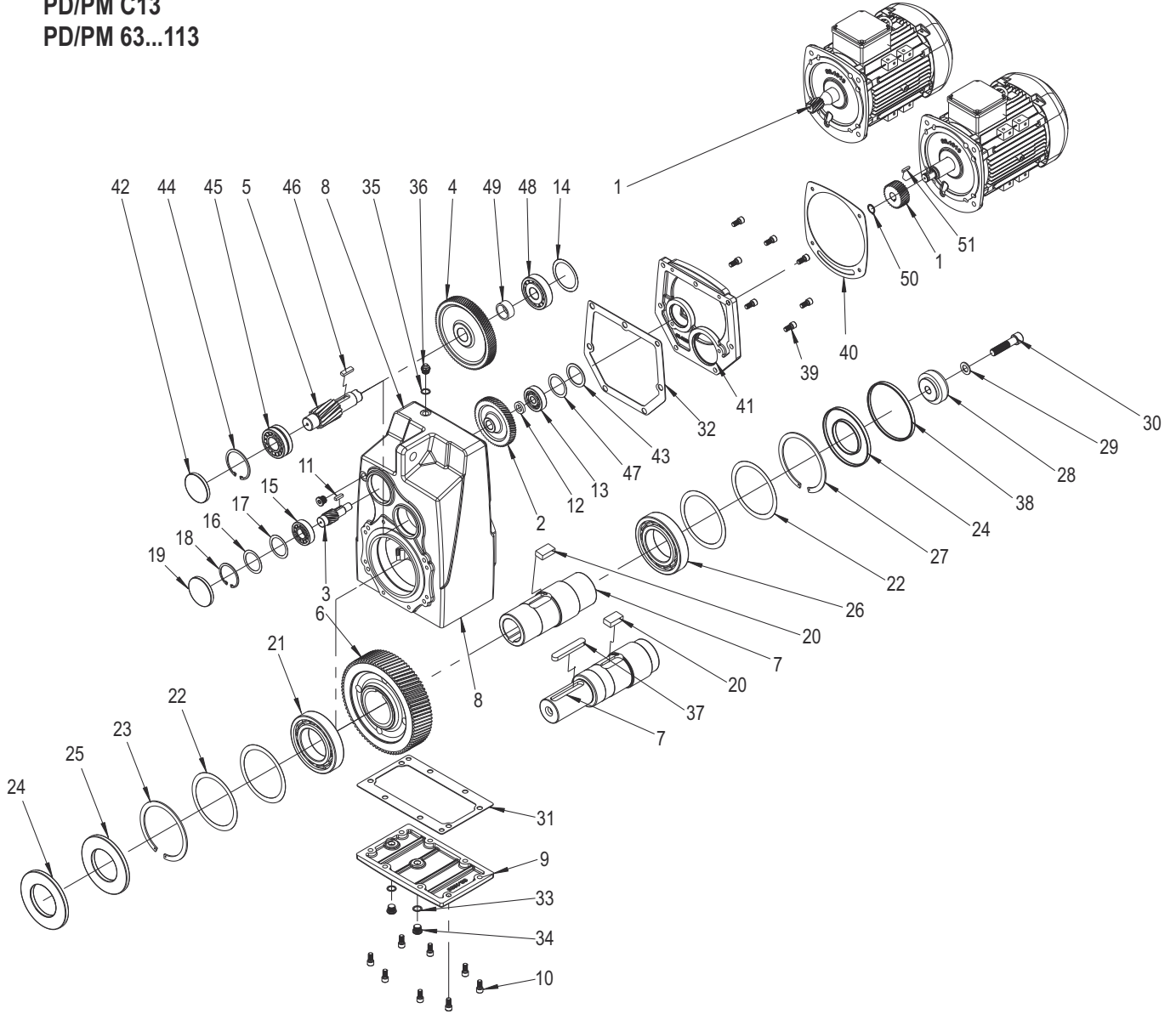

1. Z1 Dişlisi
2. Z2 Dişlisi
3. Z3 Dişlisi
4. Z4 Dişlisi
5. Z5 Dişlisi
6. Z6 Dişlisi
7. Çıkış Şaftı
8. Gövde
9. Gövde Kapağı
10. Alyan Başlı Civata
11. Kama
12. Rondela
13. Rulman
14. Layner
15. Rulman
16. Rondela
17. Layner
18. Segman
19. Yağ Kapağı
20. Kama
21. Rulman
22. Layner
23. Segman
24. Şaft Keçesi

25. Şaft Keçesi
26. Rulman
27. Segman
28. Çektirme Rondelası
29. Yaylı Rondela
30. Alyan Başlı Civata
31. Conta
32. Conta
33. Conta
34. Boşaltma Tapası
35. Conta
36. Havalandırma Tapası
37. Kama
38. Yağ Kapağı
39. Alyan Başlı Civata
40. Conta
41. Ara Bağlantı Flanşı
42. Yağ Kapağı
43. Rondela
44. Segman
45. Rulman
46. Kama
47. Layner
48. Rulman

1. Pinion
2. Driven Gear
3. Pinion
4. Driven Gear
5. Pinion
6. Driven Gear
7. Output Shaft
8. Gear Case
9. Gear Case Cover
10. Socket Head Screw
11. Key
12. Supporting Disc
13. Bearing
14. Shim
15. Bearing
16. Supporting Disc
17. Shim
18. Circlip
19. Locking Cap
20. Key
21. Bearing
22. Shim
23. Circlip
24. Shaft Seal

25. Shaft Seal
26. Bearing
27. Circlip
28. Fixing Element
29. Spring Washer
30. Socket Head Screw
31. Gasket
32. Gasket
33. Gasket
34. Drain Plug
35. Gasket
36. Vent Plug
37. Kama
38. Locking Cap
39. Socket Head Screw
40. Gasket
41. Intermediate Flange
42. Locking Cap
43. Supporting Disc
44. Circlip
45. Bearing
46. Key
47. Shim
48. Bearing

PD/PM 13...53

(İndirgeyici Gövde / Reduction Case)

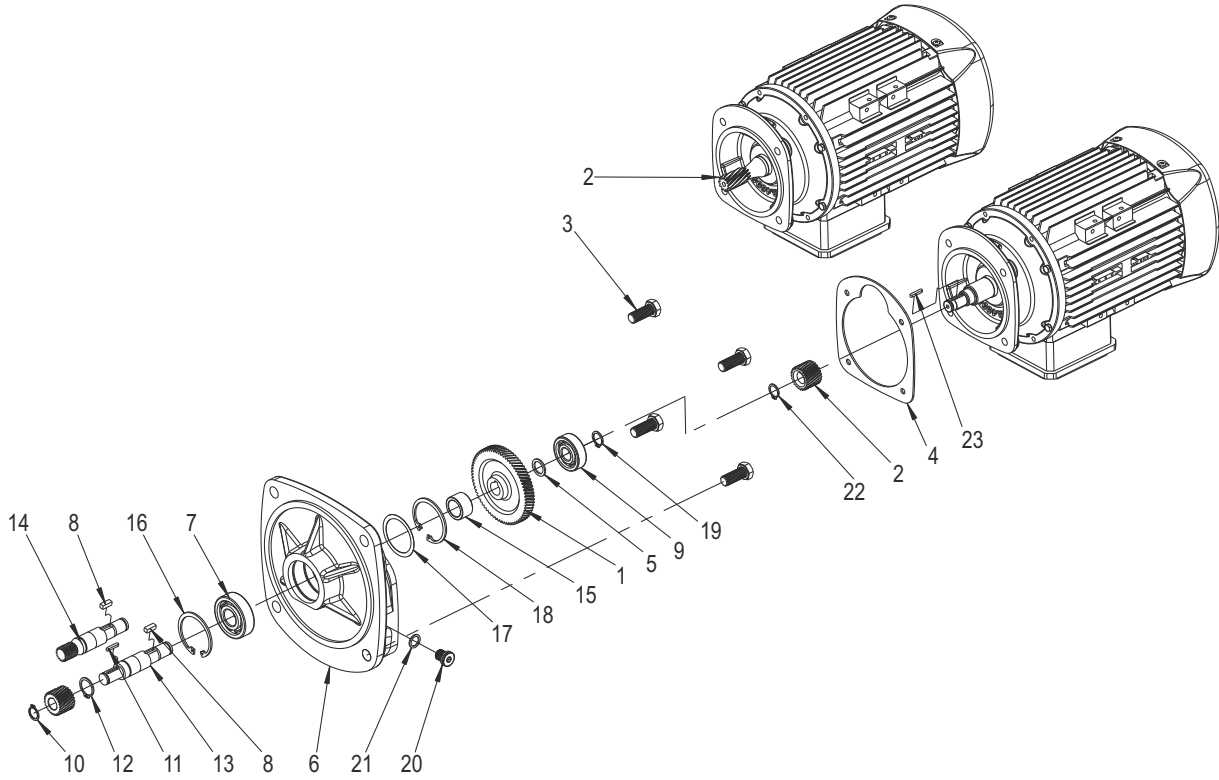

1. Z2 Dişlisi
2. Z1 Dişlisi
3. Civata
4. Conta
5. Rondela
6. İndirgeyici Gövdesi
7. Rulman
8. Segman
9. Rulman
10. Segman
11. Kama
12. Segman
13. İndirgeyici Mili Çakma
14. İndirgeyici Mili Yekpare
15. Burç
16. Segman
17. Layner
18. Segman
19. Segman
20. Tapa
21. Conta
22. Segman
23. Kama

1. Driven Gear
2. Pinion
3. Bolt
4. Gasket
5. Supporting Disc
6. Reduction Gear Case
7. Bearing
8. Key
9. Bearing
10. Circlip
11. Key
12. Circlip
13. Intermediate Shaft, Plain
14. Intermediate Shaft, Gearcut
15. Supporting Disc
16. Circlip
17. Shim
18. Circlip
19. Circlip
20. Plug
21. Gasket
22. Circlip
23. Key

TR

GENEL PARÇA LİSTESİ

EN

GENERAL PART LIST

PD/PM 12/02 ... PD/PM 113/52

(PF = 02 ... 52)

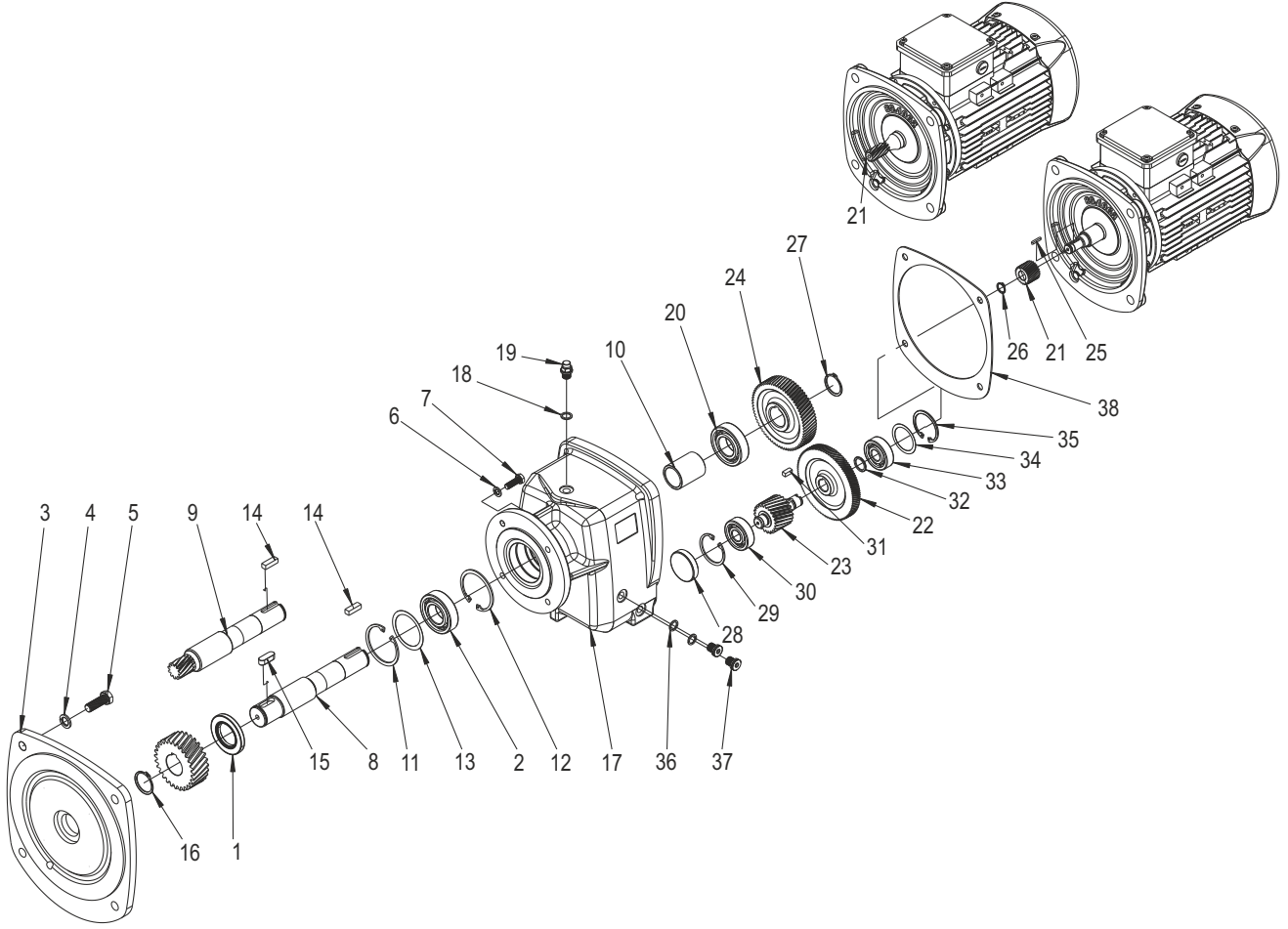

1. Şaft Keçesi
2. Rulman
3. Ara Flanşı
4. Yaylı Rondela
5. Cıvata
6. Yaylı Rondela
7. Cıvata
8. Ara Mil Çakma
9. Ara Mil Yekpare
10. Ara Burç
11. Segman
12. Segman
13. Layner
14. Kama
15. Kama
16. Segman
17. Gövde
18. Conta
19. Havalandırma Tapası

20. Rulman
21. Z1 Dişlisi
22. Z2 Dişlisi
23. Z3 Dişlisi
24. Z4 Dişlisi
25. Kama
26. Segman
27. Segman
28. Yağ Kapağı
29. Segman
30. Rulman
31. Kama
32. Rondela
33. Rulman
34. Layner
35. Segman
36. Conta
37. Boşaltma Tapası
38. Conta

1. Shaft Seal
2. Bearing
3. Intermediate Flange
4. Spring Washer
5. Bolt
6. Spring Washer
7. Bolt
8. Intermediate Shaft, Plain
9. Intermediate Shaft, Gearcut
10. Supporting Disc
11. Circlip
12. Circlip
13. Shim
14. Key
15. Key
16. Circlip
17. Gear Case
18. Gasket
19. Vent Plug

20. Bearing
21. Pinion
22. Driven Gear
23. Pinion
24. Driven Gear
25. Key
26. Circlip
27. Circlip
28. Locking Cap
29. Circlip
30. Bearing
31. Key
32. Supporting Disc
33. Bearing
34. Shim
35. Circlip
36. Gasket
37. Drain Plug
38. Gasket

PD/PM A02...112
PD/PM C13...123

(AKSESUARLAR / ACCESSORIES)

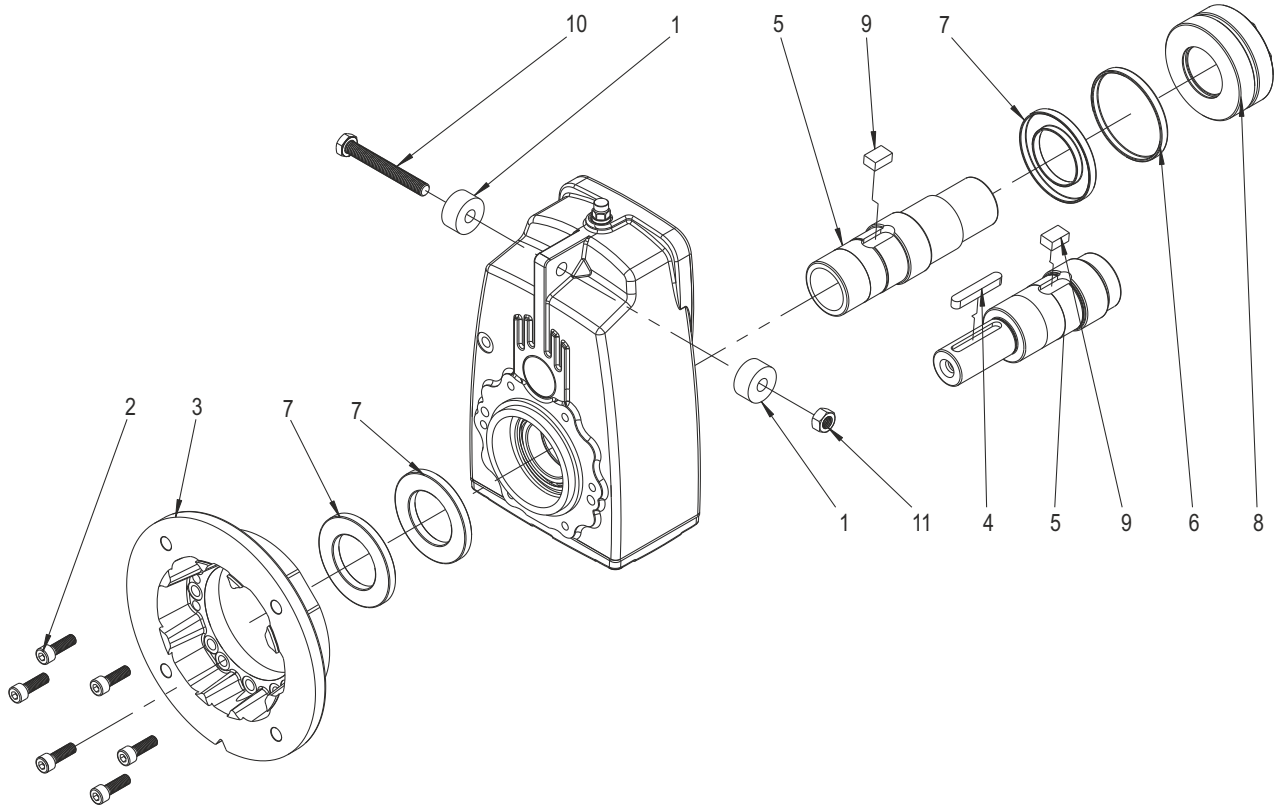

1. Lastik Takoz
2. Alıyan Başlı Civata
3. B5 Flanşı
4. Kama
5. Çıkış Şaftı
6. Yağ Kapağı
7. Şaft Keçesi
8. Konik Sıktırma
9. Kama
10. Civata
11. Somun

1. Rubber Buffer
2. Socket Head Screw
3. Flange B5
4. Key
5. Output Shaft
6. Locking Cap
7. Shaft Seal
8. Shrink Disc
9. Key
10. Bolt
11. Nut

TR

GENEL PARÇA LİSTESİ

EN

GENERAL PART LIST

IEC 63...112

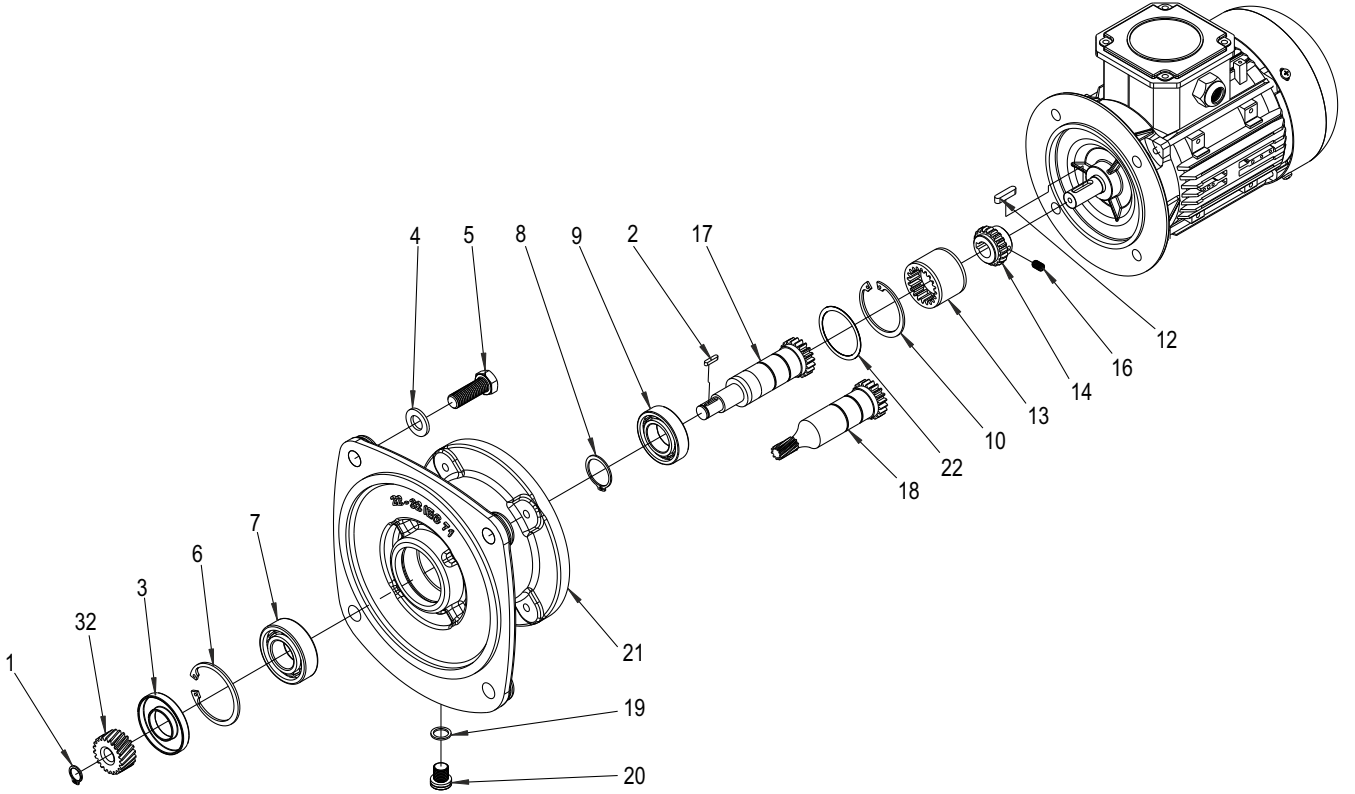

1. Segman
2. Kama
3. Şaft Keçesi
4. Yaylı Rondela
5. Altıköşe Başlı Civata
6. Segman
7. Rulman
8. Segman
9. Rulman
10. Segman
12. Kama
13. Kaplin
14. Kaplin
16. Setuskur Civata
17. IEC Mili Çakma
18. IEC Mili Yekpare
19. Conta
20. Yağ Tapası
21. IEC Gövde
22. Layner
32. Z1 Dişlisi

1. Circlip
2. Key
3. Shaft Seal
4. Spring Washer
5. Bolt
6. Circlip
7. Bearing
8. Circlip
9. Bearing
10. Circlip
12. Key
13. Coupling
14. Coupling
16. Set Screw
17. Input Shaft, Plain
18. Input Shaft, Gearcut
19. Gasket
20. Oil Plug
21. IEC Adapter
22. Shim
32. Pinion

IEC 132...180

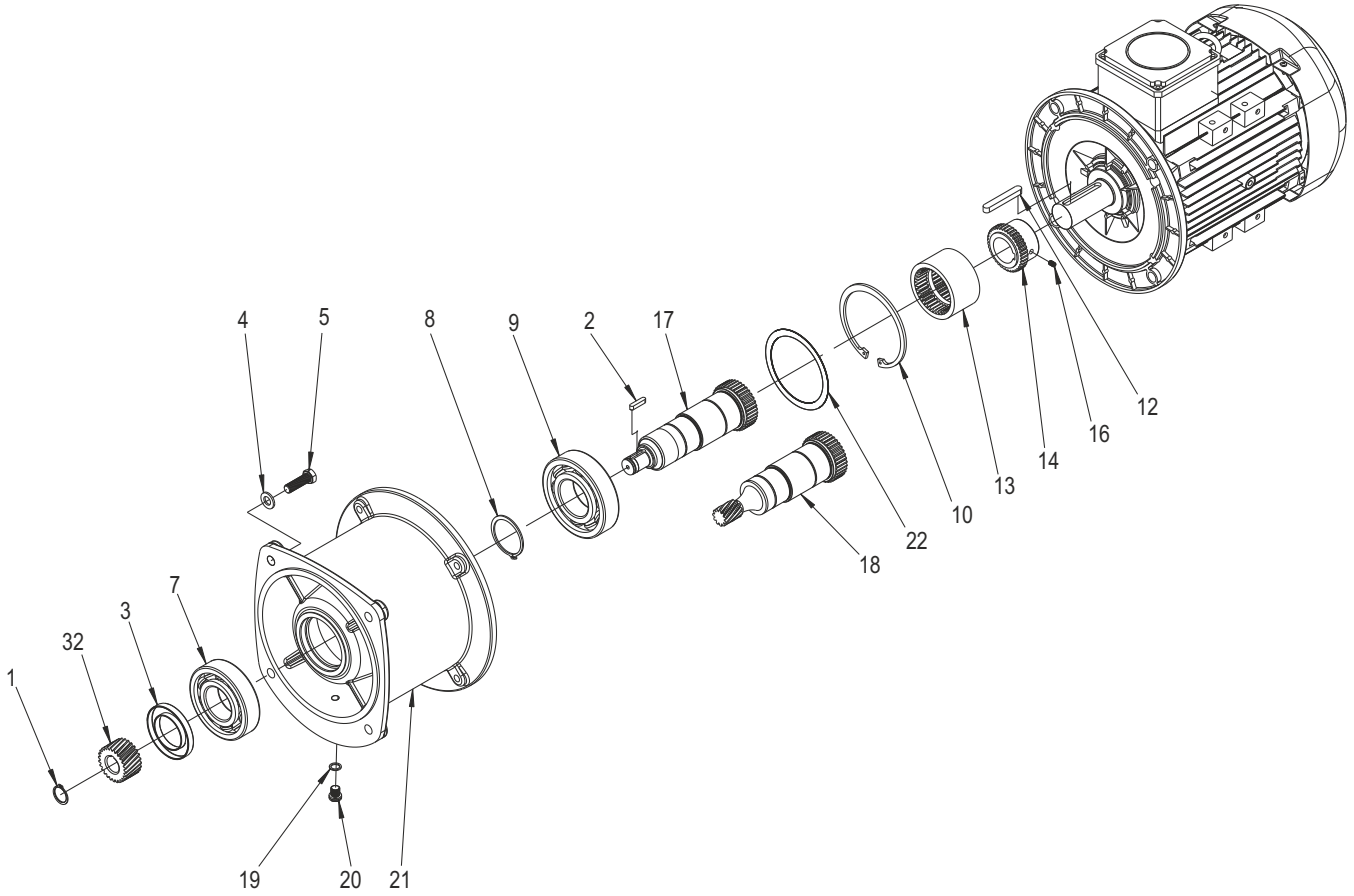

1. Segman
2. Kama
3. Şaft Keçesi
4. Yaylı Rondela
5. Altıköşe Başlı Civata
7. Rulman
8. Segman
9. Rulman
10. Segman
12. Kama
13. Kaplin
14. Kaplin
16. Setuskur Civata
17. IEC Mili Çakma
18. IEC Mili Yekpare
19. Conta
20. Yağ Tapası
21. IEC Gövde
22. Layner
32. Z1 Dişlisi

1. Circlip
2. Key
3. Shaft Seal
4. Spring Washer
5. Bolt
7. Bearing
8. Circlip
9. Bearing
10. Circlip
12. Key
13. Coupling
14. Coupling
16. Set Screw
17. Input Shaft, Plain
18. Input Shaft, Gearcut
19. Gasket
20. Oil Plug
21. IEC Adapter
22. Shim
32. Pinion

TR

GENEL PARÇA LİSTESİ

EN

GENERAL PART LIST

IEC 160...315

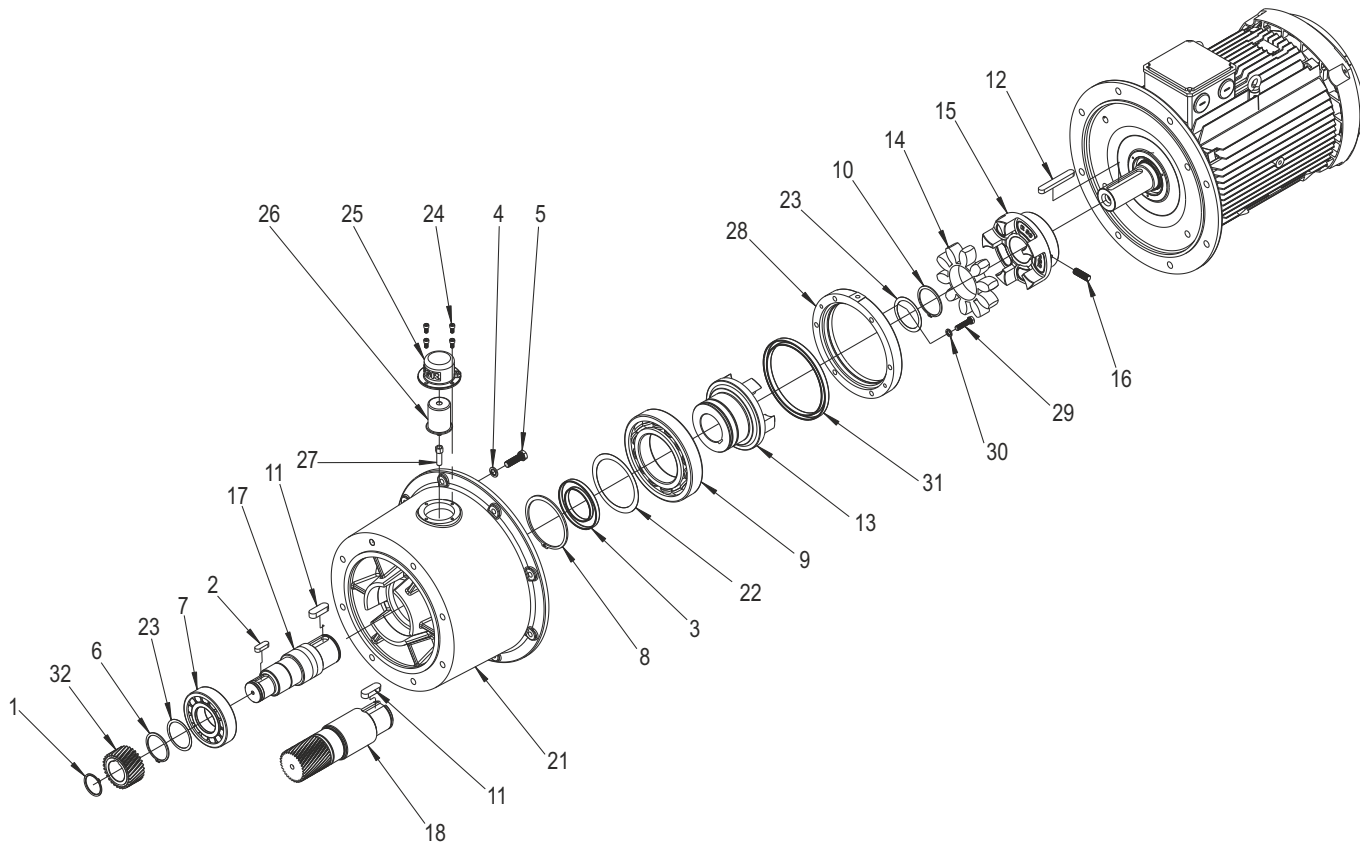

1. Segman
2. Kama
3. Şaft Keçesi
4. Yaylı Rondela
5. Altıköşe Başlı Civata
6. Segman
7. Rulman
8. Segman
9. Rulman
10. Segman
11. Kama
12. Kama
13. Kaplin
14. Kaplin
15. Kaplin
16. Setuskur Civata
17. IEC Mili Çakma
18. IEC Mili Yekpare
21. IEC Gövde
22. Layner
23. Layner
24. Alyan Başlı Civata
25. Kapak
26. Otomatik Yağlayıcı
27. Adaptör
28. Rulman Kapağı
29. Altıköşe Başlı Civata
30. Yağlı Rondela
31. Şaft Keçesi
32. Z1 Dişlisi

1. Circlip
2. Key
3. Shaft Seal
4. Spring Washer
5. Bolt
6. Circlip
7. Bearing
8. Circlip
9. Bearing
10. Circlip
11. Key
12. Key
13. Coupling
14. Coupling
15. Coupling
16. Set Screw
17. Input Shaft, Plain
18. Input Shaft, Gearcut
21. IEC Adapter
22. Shim
23. Shim
24. Socket Head Screw
25. Cover
26. Automatic Lubricator
27. Adapter
28. Bearing Cover
29. Bolt
30. Spring Washer
31. Shaft Seal
32. Pinion

PD/PM A02...C13
PD/PM 12...52
PD/PM 13...63

W

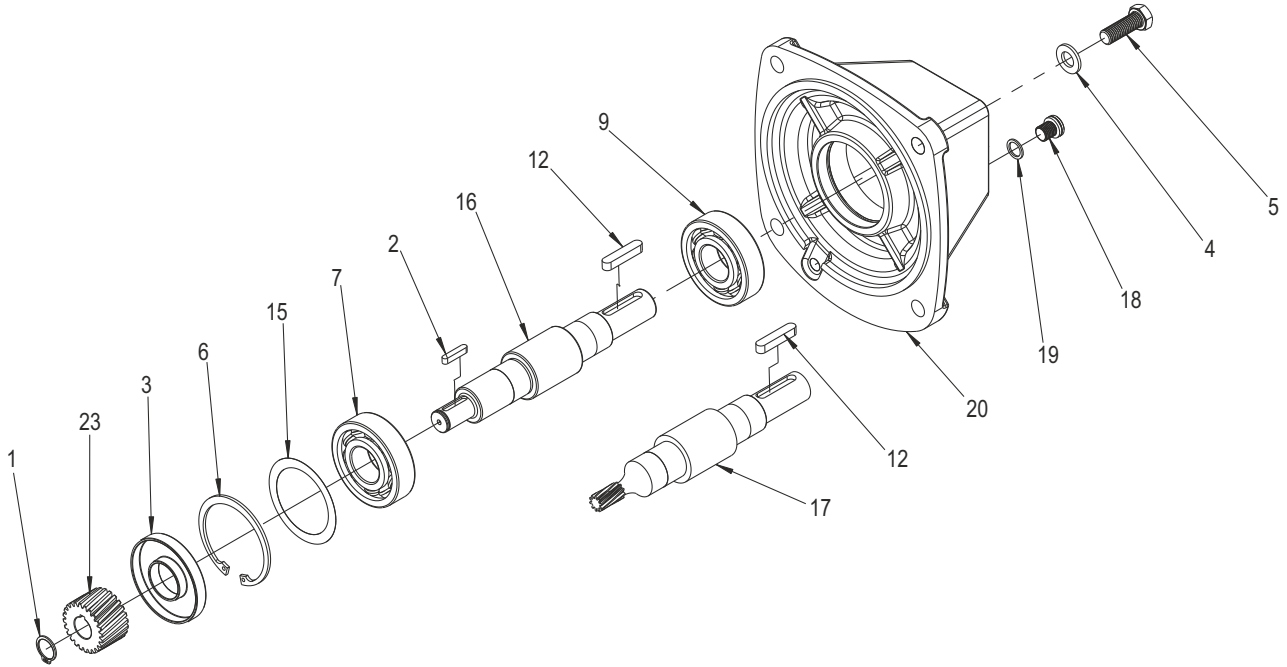

1. Segman
2. Kama
3. Şaft Keçesi
4. Yaylı Rondela
5. Altıköşe Başlı Civata
6. Segman
7. Rulman
9. Rulman
12. Kama
15. Layner
16. W Mili Çakma
17. W Mili Yekpare
18. Yağ Tapası
19. Conta
20. W Gövdesi
23. Z1 Dişlisi

1. Circlip
2. Key
3. Shaft Seal
4. Spring Seal
5. Hexagon Screw
6. Circlip
7. Bearing
9. Bearing
12. Key
15. Shim
16. Input Shaft, Plain
17. Input Shaft, Gearcut
18. Drain Plug
19. Gasket
20. W Input Housing
23. Pinion

TR

GENEL PARÇA LİSTESİ

EN

GENERAL PART LIST

PD/PM 62...72 - PD/PM 73...93

W

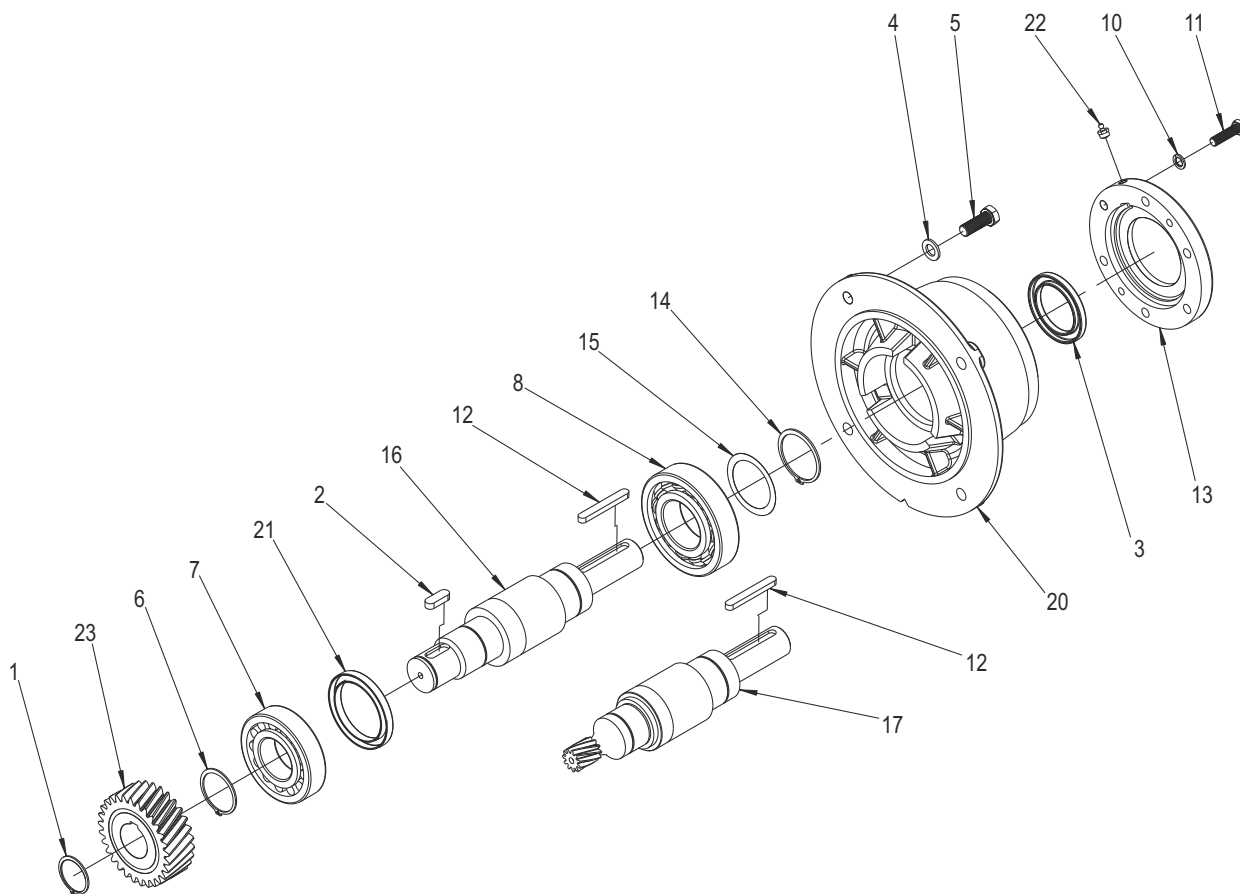

- | | |
|---------------------------|--------------------------|
| 1. Segman | 1. Circlip |
| 2. Kama | 2. Key |
| 3. Şaft Keçesi | 3. Shaft Seal |
| 4. Yaylı Rondela | 4. Spring Washer |
| 5. Altıköşe Başlı Civata | 5. Hexagon Screw |
| 6. Segman | 6. Circlip |
| 7. Rulman | 7. Bearing |
| 8. Rulman | 8. Bearing |
| 10. Yaylı Rondela | 10. Spring Washer |
| 11. Altıköşe Başlı Civata | 11. Hexagon Screw |
| 12. Kama | 12. Key |
| 13. Rulman Kapağı | 13. Bearing Cover |
| 14. Segman | 14. Circlip |
| 15. Layner | 15. Shim |
| 16. W Mili Çakma | 16. Input Shaft, Plain |
| 17. W Mili Yekpare | 17. Input Shaft, Gearcut |
| 20. W Gövdesi | 20. W Input Housing |
| 21. Şaft Keçesi | 21. Shaft Seal |
| 22. Gresörlük | 22. Grease Nipple |
| 23. Z1 Dişlisi | 23. Pinion |

TR

GENEL PARÇA LİSTESİ

PD/PM 82...92

EN

GENERAL PART LIST

W

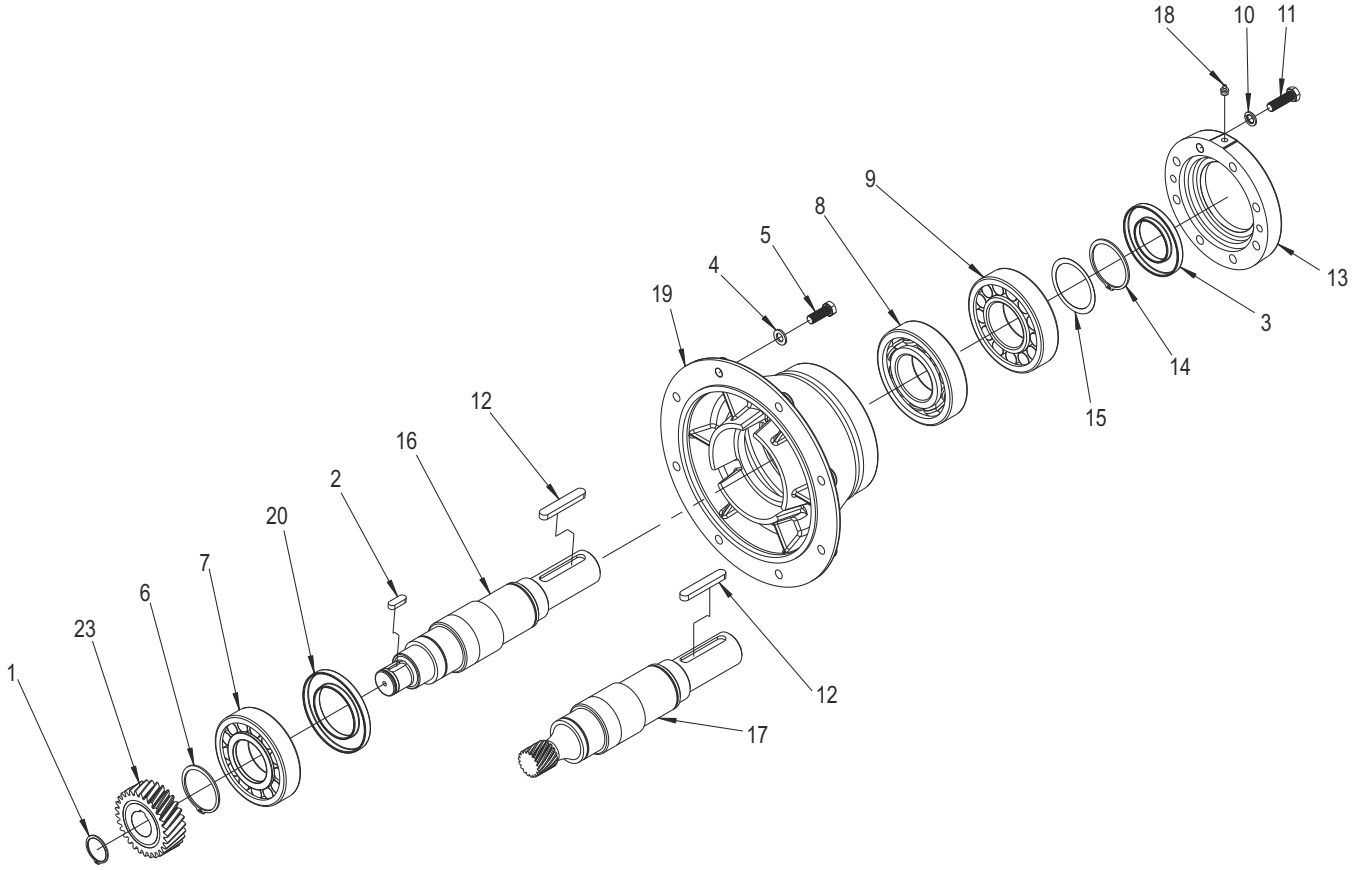

1. Segman
2. Kama
3. Şaft Keçesi
4. Yaylı Rondela
5. Altıköşe Başlı Civata
6. Segman
7. Rulman
8. Rulman
9. Rulman
10. Yaylı Rondela
11. Altıköşe Başlı Civata
12. Kama
13. Rulman Kapağı
14. Segman
15. Layner
16. W Mili Çakma
17. W Mili Yekpare
18. Gresörlük
19. W Gövdesi
20. Şaft Keçesi
23. Z1 Dişlisi

1. Circlip
2. Key
3. Shaft Seal
4. Spring Washer
5. Hexagon Screw
6. Circlip
7. Bearing
8. Bearing
9. Bearing
10. Spring Washer
11. Hexagon Screw
12. Key
13. Bearing Cover
14. Circlip
15. Shim
16. Input Shaft, Plain
17. Input Shaft, Gearcut
18. Grease Nipple
19. Input Bearing Housing
20. Shaft Seal
23. Pinion

TR

GENEL PARÇA LİSTESİ

EN

GENERAL PART LIST

PD/PM 102...123

W

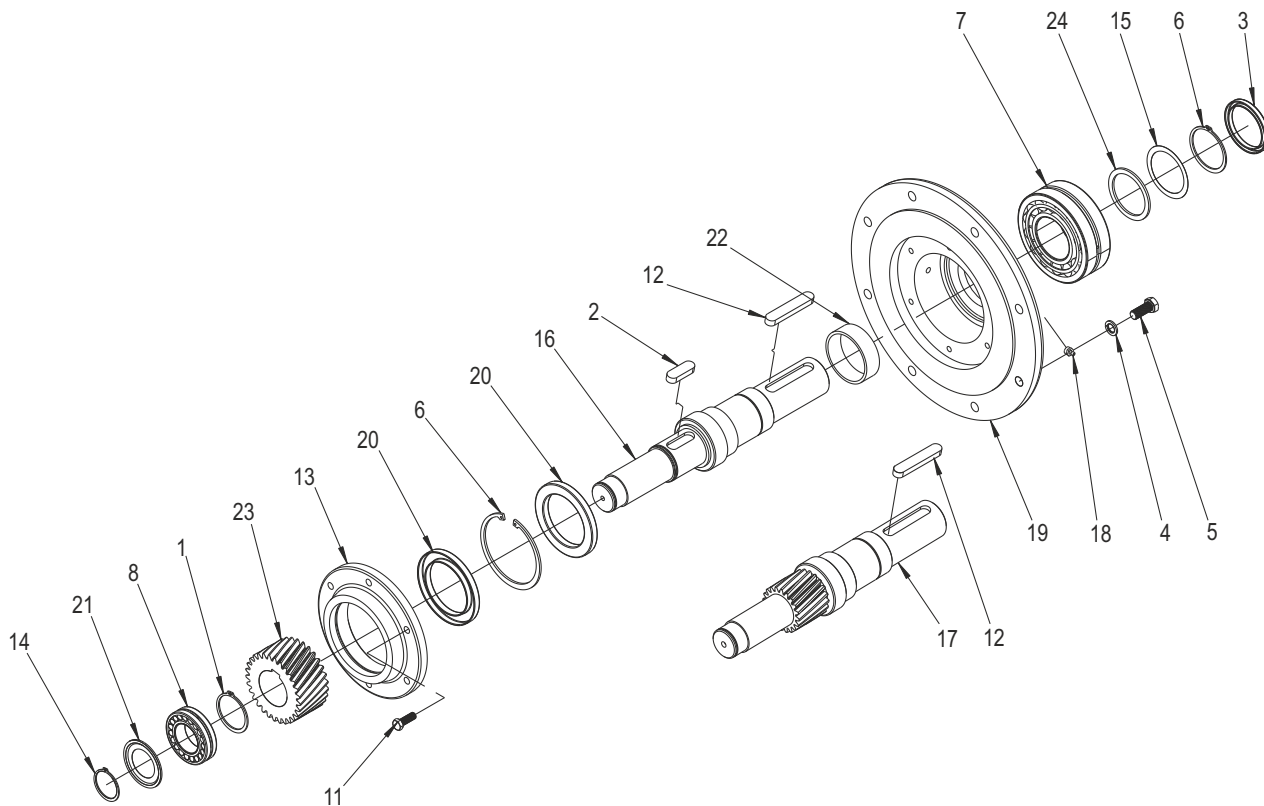

1. Segman
2. Kama
3. Şaft Keçesi
4. Yaylı Rondela
5. Altıköşe Başlı Civata
6. Segman
7. Rulman
8. Rulman
11. Altıköşe Başlı Civata
12. Kama
13. Rulman Kapağı
14. Segman
15. Layner
16. W Mili Çakma
17. W Mili Yekpare
18. Gresörlük
19. W Gövdesi
20. Şaft Keçesi
21. Nilosring
22. Rondela
23. Z1 Dişlisi
24. Rondela
25. Segman

1. Circlip
2. Key
3. Shaft Seal
4. Spring Washer
5. Hexagon Screw
6. Circlip
7. Bearing
8. Bearing
11. Hexagon Screw
12. Key
13. Bearing Cover
14. Circlip
15. Shim
16. Input Shaft, Plain
17. Input Shaft, Gearcut
18. Grease Nipple
19. Input Bearing Housing
20. Shaft Seal
21. Nilosring
22. Supporting Disc
23. Pinion
24. Supporting Disc
25. Circlip

PAM B5 : 63 - 71
PAM B5 : 100...315

PAM (B5/B14)

PAM B14 : 63 - 71
PAM B14 : 100 - 132

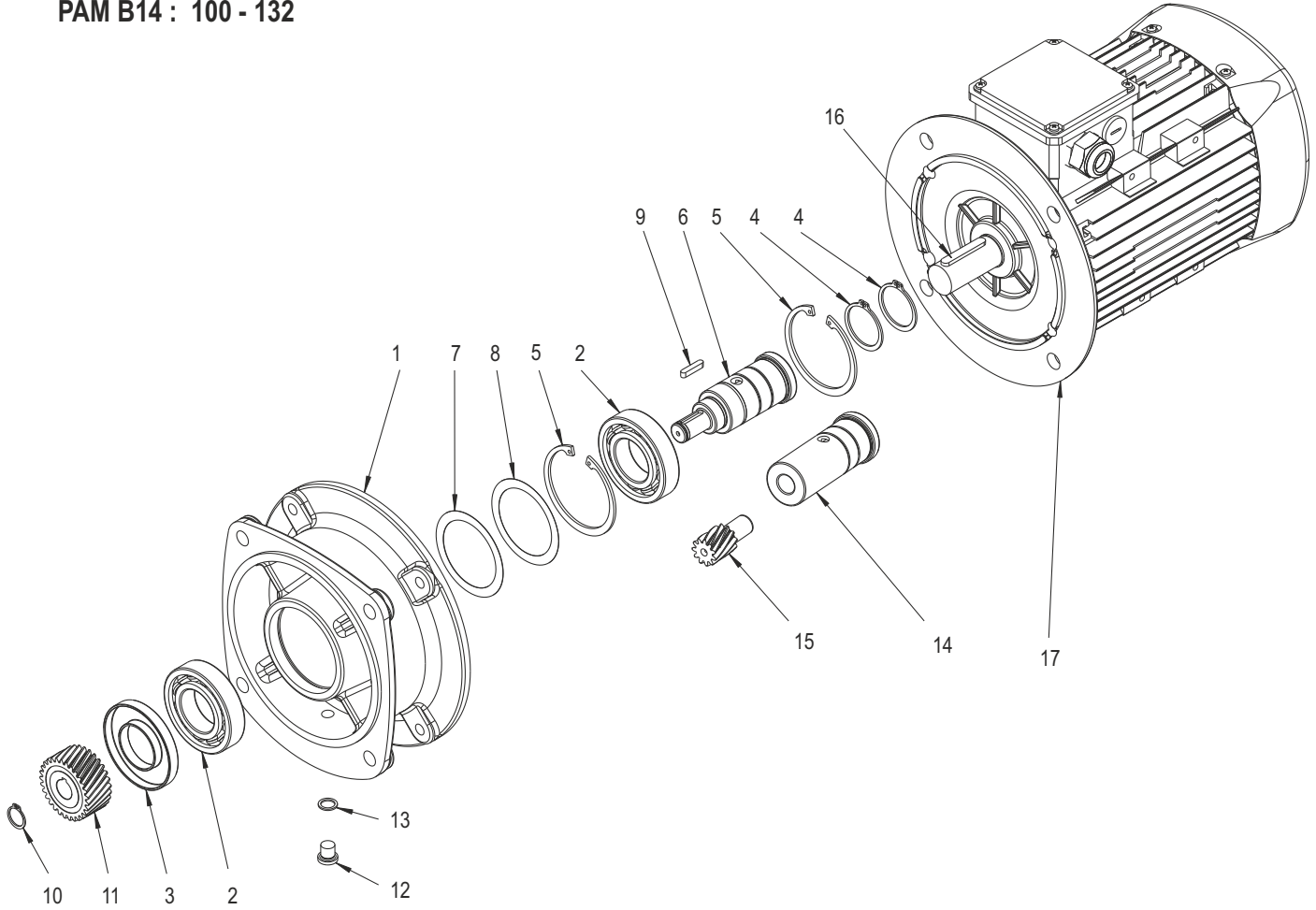

1. Pam Gövde (B5/B14)

2. Rulman
3. Keçe
4. Segman
5. Segman
6. Pam mili çakma
7. Layner
8. Layner
9. Kama
10. Segman
11. Z1 Dişlisi
12. Yağ Tapası
13. Conta
14. Pam mili yekpare çakma
15. Z1 Dişlisi
16. Motor Kaması
17. Motor

1. Pam Adapter (B5/B14)

2. Bearing
3. Seal
4. Circlip
5. Circlip
6. Input Shaft, Plain
7. Shim
8. Shim
9. Key
10. Circlip
11. Pinion
12. Oil plug
13. Gasket
14. Input Shaft, Gearcut
15. Pinion
16. Key
17. Motor

TR

GENEL PARÇA LİSTESİ

EN

GENERAL PART LIST

PAM B5 : 80 - 90

PAM (B5/B14)

PAM B14 : 80 - 90

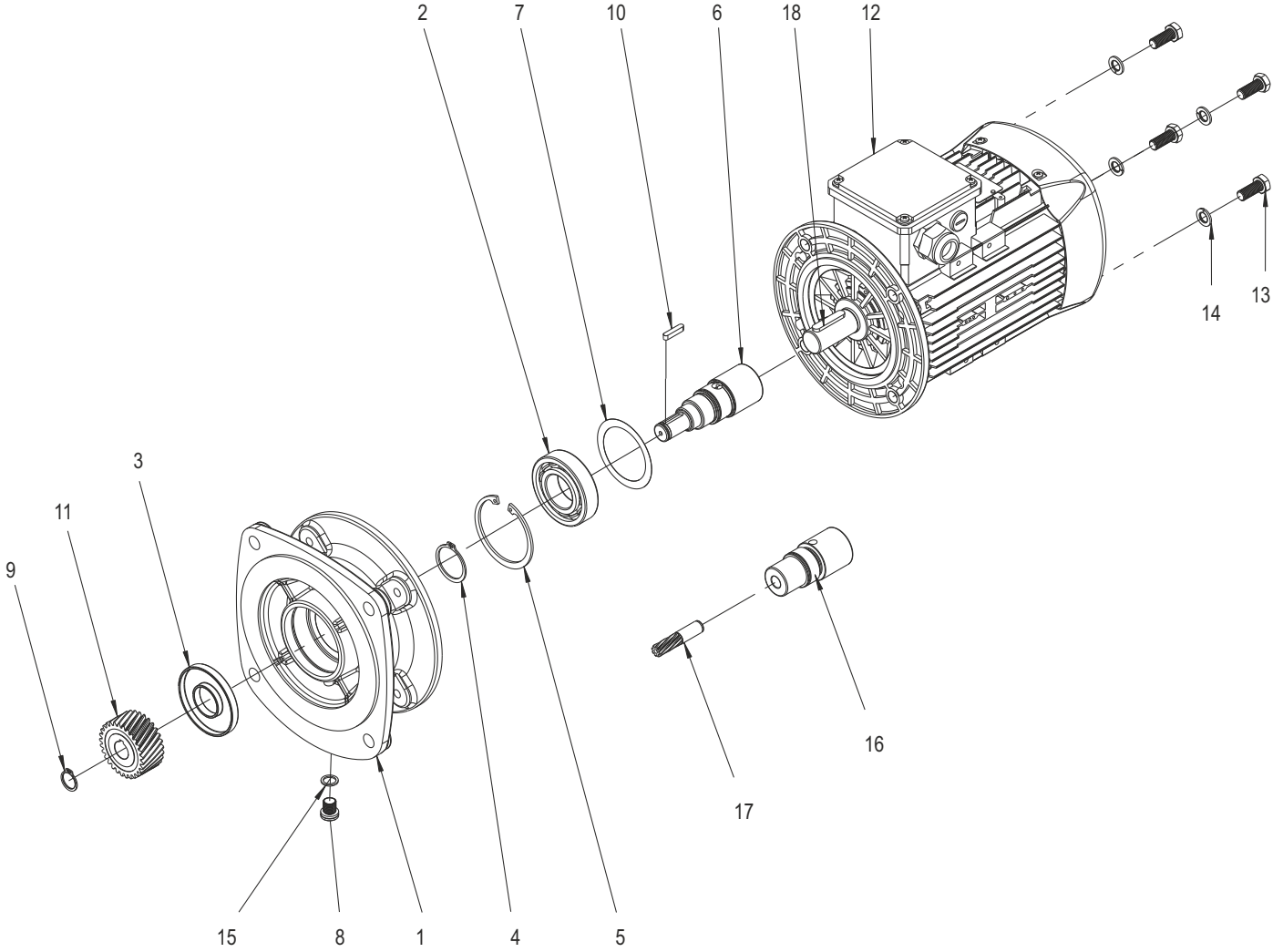

1. Pam Gövde (B5/B14)
2. Rulman
3. Keçe
4. Segman
5. Segman
6. Pam mili çakma
7. Layner
8. Yağ Tapası
9. Segman
10. Kama
11. Z1 Dişlisi
12. Motor
13. Cıvata
14. Yaylı Rondela
15. Conta
16. Pam mili yekpare çakma
17. Z1 Dişlisi
18. Motor Kaması

1. Pam Adapter (B5/B14)
2. Bearing
3. Seal
4. Circlip
5. Circlip
6. Input Shaft, Plain
7. Shim
8. Oil plug
9. Circlip
10. Key
11. Pinion
12. Motor
13. Bolt
14. Spring Washer
15. Gasket
16. Input Shaft, Gearcut
17. Pinion
18. Key

ELEKTRİKSEL ÖZELLİKLER - 50 Hz / ELECTRICAL CHARACTERISTICS AT 50 Hz

Motor Tipi Motor Type	Gövde Tipi Housing Type	Nominal / Rated Values					Kalkıştaki Değerler / Starting Values					Devirline Moment / Oran Brake/Down Torque Ratio Mk/Mn	Verim * Efficiency*			Cos φ	J kgm ²	Ağırlık (B3) Weight (B3) kg	Ses Seviyesi dB(A)** Sound Pressure Level dB(A)**
		Güç / Power kW	HP	Devir Speed d/d	Akım Current A	Moment Torque Nm	Akım Current I _A / A _N	Moment Torque M _A / M _N	η%	4/4	3/4		2/4						
2kutup3000d/d																			
220/380V	Q3E80M2C	Alüminyum	0,75	1,0	2880	1,7	2,5	7,4	-	4,0	-	4,8	80,7	79,1	77,4	0,86	0,00109	12,2	58
	Q3E80M2D	Alüminyum	1,1	1,5	2895	2,4	3,7	8,4	-	4,9	-	5,1	82,7	82,1	78,9	0,84	0,00150	13	58
	Q3E90L2C	Alüminyum	1,5	2,0	2910	3,2	4,9	8,9	-	4,2	-	4,9	84,2	84,7	82,3	0,86	0,00182	17,5	62
	Q3E90L2D	Alüminyum	2,2	3,0	2900	4,6	7,2	8,6	-	4,6	-	4,0	85,9	87,0	85,5	0,84	0,00182	18	62
	Q3E100L2D	Alüminyum	3,0	4,0	2920	5,6	9,8	9,8	-	4,1	-	4,4	87,1	86,9	84,5	0,89	0,00335	25	64
380/660V	Q3E112M2C	Alüminyum	4,0	5,5	2915	7,8	13,2	3,2	9,7	1,3	3,8	5,1	88,1	87,9	85,7	0,87	0,00489	31	67
	Q3E132S2C	Alüminyum	5,5	7,5	2900	10,4	18,0	3,6	10,8	1,0	3,0	3,5	89,2	88,9	86,7	0,91	0,01410	48	70
	Q3E132M2A	Alüminyum	7,5	10,0	2930	13,7	24,5	3,2	9,7	1,3	3,8	4,4	90,1	90,3	88,9	0,91	0,01596	51	70
	Q3E160L2A	Alüminyum	11,0	15,0	2940	19,8	35,9	2,9	8,8	1,0	3,0	5,1	91,2	91,4	90,3	0,93	0,03317	77	71
	Q3E160L2C	Alüminyum	15,0	20,0	2945	26,7	48,8	3,6	10,8	1,1	3,2	3,9	91,9	91,0	90,3	0,93	0,04075	91	71
	Q3E160L2D	Alüminyum	18,5	25,0	2940	33,4	60,0	2,9	8,8	1,3	3,8	4,1	92,4	92,0	90,9	0,91	0,04075	101	71
	Q3E180M2A	Alüminyum	22,0	30,0	2955	38,7	71,3	3,5	10,5	1,1	3,2	3,2	92,7	92,9	91,7	0,93	0,06193	139	77
	Q3E200L2C	Alüminyum	30,0	40,0	2950	52,9	97,4	3,0	9,1	0,8	2,4	3,5	93,3	93,8	93,4	0,93	0,11917	167	80
	Q3E200L2D	Alüminyum	37,0	50,0	2950	65,2	119,5	3,2	9,7	0,9	2,7	3,5	93,7	94,1	93,8	0,92	0,15010	179	80
	Q3E225M2C	Alüminyum	45,0	60,0	2965	80,3	145,2	2,7	8,0	0,8	2,4	3,4	94,0	94,0	93,2	0,91	0,23505	249	81
	Q3EP250M2C	Pik	55,0	75,0	2980	95,9	178,5	2,1	6,4	0,7	2,1	3,1	94,3	94,0	92,6	0,91	0,48707	488	82
	Q3EP280M2C	Pik	75,0	100,0	2975	125,4	240,8	2,7	8,0	0,6	1,9	4,0	94,7	94,0	92,7	0,92	0,54033	585	84
	Q3EP280M2D	Pik	90,0	125,0	2975	151,3	289,4	2,7	8,0	0,7	2,1	4,9	95,0	94,2	92,7	0,93	0,64510	587	84
400/690V	Q3EP315S2C	Pik	110,0	127,0	2.983	187	358	2,4	7,2	0,6	1,7	2,6	95,2	95,2	94,0	0,89	2,19900	963	83
	Q3EP315M2B	Pik	132,0	152,0	2.983	224	418	2,5	7,5	0,6	1,8	2,6	95,4	95,4	94,4	0,89	2,37790	1.007	83
	Q3EP315L2A	Pik	160,0	184,0	2.983	271	513	2,5	7,5	0,6	1,8	2,6	95,6	95,6	94,4	0,89	2,62170	1.065	83
	Q3EP315L2C	Pik	200,0	230,0	2.983	339	641	2,5	7,5	0,6	1,9	2,6	95,8	95,8	94,9	0,89	2,90860	1.180	83
	Q3EP355M2C	Pik	250,0	280,0	2.983	419	800	2,4	7,3	0,6	1,7	2,5	95,8	95,8	94,7	0,90	3,81300	1.612	91
	Q3EP355L2B	Pik	315,0	353,0	2.984	527	1.008	2,4	7,3	0,6	1,8	2,5	95,8	95,7	94,4	0,90	4,52000	1.771	91
	Q3EP355L2C	Pik	355,0	398,0	2.981	594	1.137	2,6	7,9	0,7	2,2	2,5	95,8	95,8	95,0	0,90	5,58000	2.002	91
4kutup1500d/d																			
220/380V	Q3E80M4D	Alüminyum	0,75	1,0	1430	1,8	5,0	6,1	-	3,0	-	3,1	82,5	81,2	78,0	0,77	0,00268	12	49
	Q3E90L4C	Alüminyum	1,1	1,5	1440	2,5	7,4	7,5	-	2,9	-	3,3	84,1	84,1	81,3	0,80	0,00365	18	54
	Q3E90L4D	Alüminyum	1,5	2,0	1440	3,5	10,0	7,9	-	3,2	-	3,6	85,3	84,9	82,0	0,76	0,00365	18	55
	Q3E100L4C	Alüminyum	2,2	3,0	1445	5,1	14,6	7,6	-	3,7	-	4,0	86,7	84,4	82,0	0,78	0,00545	26	56
	Q3E100L4D	Alüminyum	3,0	4,0	1435	7,1	19,9	8,2	-	3,8	-	4,1	87,7	87,3	85,5	0,73	0,00581	26	56
380/660V	Q3E112M4D	Alüminyum	4,0	5,5	1445	8,3	26,3	2,8	8,3	1,0	3,0	4,0	88,6	87,6	85,8	0,83	0,01123	31	58
	Q3E132M4B	Alüminyum	5,5	7,5	1465	11,4	36,2	2,3	6,8	1,1	3,2	3,9	89,6	89,0	86,8	0,80	0,02763	54	61
	Q3E132M4C	Alüminyum	7,5	10,0	1450	15,8	49,4	2,5	7,4	1,0	3,0	4,1	90,4	89,3	87,4	0,82	0,02980	57	61
	Q3E160L4A	Alüminyum	11,0	15,0	1470	23,0	71,9	2,4	7,1	1,0	3,0	3,6	91,4	90,7	89,4	0,81	0,06922	90	63
	Q3E160L4B	Alüminyum	15,0	20,0	1465	30,8	98,0	2,7	8,0	0,9	2,6	3,4	92,1	91,7	90,7	0,82	0,07991	107	63
	Q3E180M4B	Alüminyum	18,5	25,0	1470	35,3	120,7	2,8	8,3	0,8	2,4	3,1	92,6	92,5	92,2	0,86	0,11220	148	69
	Q3E180L4B	Alüminyum	22,0	30,0	1475	42,0	142,4	2,7	8,0	0,8	2,4	2,5	93,0	93,0	93,0	0,86	0,12773	157	69
	Q3E200L4D	Alüminyum	30,0	40,0	1480	54,3	193,6	2,4	7,1	0,7	2,2	2,5	93,6	93,6	93,7	0,86	0,26448	183	70
	Q3E225M4D	Alüminyum	37,0	50,0	1485	77,8	239,6	2,8	8,3	0,9	2,7	3,3	93,9	92,6	90,6	0,81	0,36429	280	71
	Q3E225M4DE	Alüminyum	45,0	60,0	1480	84,3	289,9	2,9	8,6	0,9	2,7	3,3	94,2	93,1	91,6	0,85	0,43513	282	71
	Q3EP250M4E	Pik	55,0	75,0	1450	100,0	356,1	2,6	7,7	0,9	2,7	3,2	94,6	94,0	92,8	0,87	0,90782	506	72
	Q3EP280M4C	Pik	75,0	100,0	1485	141,7	482,0	2,5	7,4	0,9	2,7	2,9	95,0	94,7	93,5	0,84	1,06114	624	73
	Q3EP280M4D	Pik	90,0	125,0	1485	163,5	584,2	2,5	7,4	0,9	2,7	2,9	95,2	94,5	93,7	0,86	1,14768	653	73
400/690V	Q3EP315S4C	Pik	110,0	127,0	1.489	194	705	2,5	7,5	0,7	2,0	2,5	95,4	95,4	94,7	0,86	3,46500	867	70
	Q3EP315M4B	Pik	132,0	152,0	1.489	232	846	2,5	7,6	0,7	2,1	2,5	95,6	95,6	95,0	0,86	3,96600	993	70
	Q3EP315L4A	Pik	160,0	184,0	1.489	274	1.026	2,5	7,6	0,7	2,2	2,5	95,8	95,8	95,4	0,88	4,88320	1.165	70
	Q3EP315L4C	Pik	200,0	230,0	1.489	346	1.282	2,7	8,2	0,7	2,2	2,5	96,0	96,0	95,5	0,87	5,23440	1.223	70
	Q3EP355M4C	Pik	250,0	280,0	1.491	422	1.601	2,5	7,5	0,6	1,9	2,4	96,0	96,0	95,5	0,89	9,30600	1.692	82
	Q3EP355L4B	Pik	315,0	353,0	1.491	532	2.017	2,5	7,5	0,6	1,9	2,4	96,0	96,0	95,5	0,89	10,06700	1.879	82
	Q3EP355L4C	Pik	355,0	398,0	1.491	600	2.273	2,5	7,5	0,7	2,0	2,3	96,0	96,0	95,5	0,89	11,90000	1.953	82

ELEKTRİKSEL ÖZELLİKLER - 50 Hz / ELECTRICAL CHARACTERISTICS AT 50 Hz

Motor Tipi Motor Type	Gövde Tipi Housing Type	Nominal / Rated Values					Kalkıştaki Değerler / Starting Values					Devirline Moment Oranı Brakedown Torque Ratio Mk/Mn	Verim * Efficiency*			Cos φ	J kgm ²	Ağırlık (B3) Weight (B3) kg	Ses Seviyesi dB(A)** Sound Pressure Level dB(A)**
		Güç / Power		Devir Speed d/d	Akım Current A	Moment Torque Nm	Akım Current I _A / A _N		Moment Torque M _A / M _N		η%								
		kW	HP				λ	Δ	λ	Δ	4/4		3/4	2/4					
6kutup1000d/d																			
220/380V	Q3E90L6C	Alüminyum	0,75	1,0	940	2,2	7,6	4,0	-	2,3	-	2,5	78,9	77,7	76,1	0,65	0,00365	18	54
	Q3E90L6D	Alüminyum	1,1	1,5	940	3,1	11,2	4,2	-	2,3	-	2,6	81,0	80,5	79,9	0,66	0,00451	20	55
	Q3E100L6D	Alüminyum	1,5	2,0	940	3,9	15,2	4,5	-	2,3	-	2,7	82,5	81,9	79,0	0,68	0,00570	26	56
	Q3E112M6D	Alüminyum	2,2	3,0	950	5,4	22,0	4,7	-	2,4	-	2,7	84,3	83,7	80,7	0,73	0,01107	32	58
380/660V	Q3E132M6B	Alüminyum	3,0	4,0	960	7,5	29,7	1,7	5,2	0,6	1,7	2,3	85,6	85,2	82,8	0,70	0,02709	58,5	61
	Q3E132M6C	Alüminyum	4,0	5,5	955	9,5	39,8	1,8	5,3	0,6	1,9	2,3	86,8	85,7	82,8	0,74	0,02921	67	61
	Q3E132M6D	Alüminyum	5,5	7,5	950	12,7	55,0	1,7	5,0	0,6	1,8	2,3	88,0	87,6	85,3	0,75	0,03347	76	61
	Q3E160L6C	Alüminyum	7,5	10,0	970	17,7	74,2	1,8	5,5	0,6	1,9	2,7	89,1	89,0	88,0	0,72	0,07663	96	63
	Q3E160L6D	Alüminyum	11,0	15,0	955	25,3	109,4	1,8	5,5	0,6	1,9	2,7	90,3	90,1	89,3	0,75	0,08129	100,5	63
	Q3E180L6B	Alüminyum	15,0	20,0	978	32,2	146,2	2,0	5,9	0,6	1,8	2,6	91,2	90,9	88,7	0,79	0,22951	155	69
	Q3E200L6C	Alüminyum	18,5	25,0	975	37,7	180,3	1,8	5,5	0,5	1,6	2,4	91,7	91,5	90,9	0,82	0,31281	165	70
	Q3E200L6D	Alüminyum	22,0	30,0	975	44,5	214,4	1,8	5,5	0,5	1,6	2,4	92,2	92,0	91,4	0,82	0,33078	170	70
	Q3E225M6C	Alüminyum	30,0	40,0	970	62,1	293,8	1,8	5,4	0,5	1,6	2,3	92,9	92,8	91,8	0,79	0,52901	237,5	71

BOYUTLAR / DIMENSIONS - B3

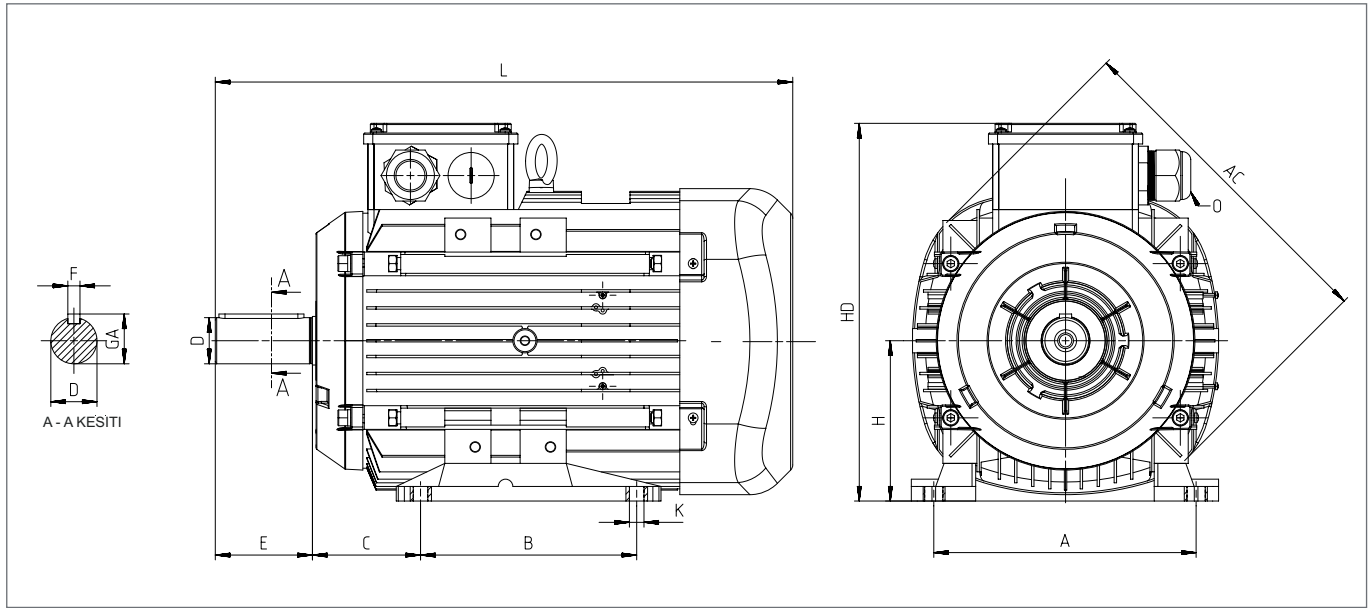

Güç Power (kW)	Kutup Sayısı Number of Poles	Motor Tipi Motor Type	Gövde Tipi Housing Type	Ana Boyutlar Main Dimensions			Ayaklı Motorlar / Foot Mounted Motors						Mil / Shaft			Rulman / Bearing		Keçe / Seal		
				AC	L	O	B	A	H	HD	K	C	D ⁽¹⁾	E	GA	F ⁽²⁾	Kasnak Tarafı Drive Side	Kasnak Tarafı Aksı Non Drive Side	Kasnak Tarafı Drive Side	Kasnak Tarafı Aksı Non Drive Side
0,75	2	Q3E80M2C	Alüminyum	158	283,5	1*M20	100	125	80	195	10	50	19	40	21,5	6	6204-2Z	6204-2Z	20*30*7	20*30*7
	4	Q3E80M4D	Alüminyum	158	283,5	1*M20	100	125	80	195	10	50	19	40	21,5	6	6204-2Z	6204-2Z	20*30*7	20*30*7
	6	Q3E90L6C	Alüminyum	193	316,5	1*M25	125	140	90	222	10	56	24	50	27	8	6305-2Z	6205-2Z	25*40*7	25*40*7
1,1	2	Q3E80M2D	Alüminyum	158	283,5	1*M20	100	125	80	195	10	50	19	40	21,5	6	6204-2Z	6204-2Z	20*30*7	20*30*7
	4	Q3E90L4C	Alüminyum	193	316,5	1*M25	100	140	90	222	10	56	24	50	27	8	6305-2Z	6205-2Z	25*40*7	25*40*7
	6	Q3E90L6D	Alüminyum	193	344,5	1*M25	125	140	90	222	10	56	24	50	27	8	6305-2Z	6205-2Z	25*40*7	25*40*7
1,5	2	Q3E90L2C	Alüminyum	193	316,5	1*M25	100	140	90	222	10	56	24	50	27	8	6305-2Z	6205-2Z	25*40*7	25*40*7
	4	Q3E90L4D	Alüminyum	193	344,5	1*M25	125	140	90	222	10	56	24	50	27	8	6305-2Z	6205-2Z	25*40*7	25*40*7
	6	Q3E100L6D	Alüminyum	217	352,0	1*M25	140	160	100	241	12	63	28	60	31	8	6306-2Z	6205-2Z	30*47*7	25*47*7
2,2	2	Q3E90L2D	Alüminyum	193	316,5	1*M25	125	140	90	222	10	56	24	50	27	8	6305-2Z	6205-2Z	25*40*7	25*40*7
	4	Q3E100L4C	Alüminyum	217	352,0	1*M25	140	160	100	241	12	63	28	60	31	8	6306-2Z	6205-2Z	30*47*7	25*40*7
	6	Q3E112M6D	Alüminyum	232	395,5	2*M25	140	190	112	261	12	70	28	60	31	8	6306-2Z	6206-2Z	30*47*7	30*47*7
3,0	2	Q3E100L2C	Alüminyum	217	352,0	1*M25	140	160	100	241	12	63	28	60	31	8	6306-2Z	6205-2Z	30*47*7	25*40*7
	4	Q3E100L4D	Alüminyum	217	377,0	1*M25	140	160	100	241	12	63	28	60	31	8	6306-2Z	6205-2Z	30*47*7	25*40*7
	6	Q3E132M6B	Alüminyum	260	481,0	2*M32	178	216	132	323	12	89	38	80	41	10	6208-2Z	6208-2Z	40*62*10	40*62*10
4,0	2	Q3E112M2C	Alüminyum	232	395,5	2*M25	140	190	112	261	12	70	28	60	31	8	6306-2Z	6206-2Z	30*47*7	30*47*7
	4	Q3E112M4C	Alüminyum	232	395,5	2*M25	140	190	112	261	12	70	28	60	31	8	6306-2Z	6206-2Z	30*47*7	30*47*7
	6	Q3E132M6C	Alüminyum	260	481,0	2*M32	178	216	132	323	12	89	38	80	41	10	6208-2Z	6208-2Z	40*62*10	40*62*10
5,5	2	Q3E132S2C	Alüminyum	279	440,5	2*M32	140	216	132	314	12	89	38	80	41	10	6208-2Z	6208-2Z	40*62*10	40*62*10
	4	Q3E132M4B	Alüminyum	279	475,5	2*M32	140	216	132	314	12	89	38	80	41	10	6208-2Z	6208-2Z	40*62*10	40*62*10
	6	Q3E132M6D	Alüminyum	260	481,0	2*M32	178	216	132	323	12	89	38	80	41	10	6208-2Z	6208-2Z	40*62*10	40*62*10
7,5	2	Q3E132M2A	Alüminyum	279	475,5	2*M32	140	216	132	314	12	89	38	80	41	10	6208-2Z	6208-2Z	40*62*10	40*62*10
	4	Q3E132M4C	Alüminyum	279	475,5	2*M32	178	216	132	314	12	89	38	80	41	10	6208-2Z	6208-2Z	40*62*10	40*62*10
	6	Q3E160L6C	Alüminyum	302	576,0	2*M32	254	254	160	360	15	108	42	110	45	12	6309-2Z	6209-2Z	45*72*10	45*72*10
11,0	2	Q3E160L2A	Alüminyum	302	576,0	2*M32	254	254	160	360	15	108	42	110	45	12	6309-2Z	6209-2Z	45*72*10	45*72*10
	4	Q3E160L4A	Alüminyum	302	576,0	2*M32	254	254	160	360	15	108	42	110	45	12	6309-2Z	6209-2Z	45*72*10	45*72*10
	6	Q3E160L6D	Alüminyum	302	576,0	2*M32	254	254	160	360	15	108	42	110	45	12	6309-2Z	6209-2Z	45*72*10	45*72*10
15,5	2	Q3E160L2C	Alüminyum	302	576,0	2*M32	254	254	160	360	15	108	42	110	45	12	6309-2Z	6209-2Z	45*72*10	45*72*10
	4	Q3E160L4B	Alüminyum	302	576,0	2*M32	254	254	160	360	15	108	42	110	45	12	6309-2Z	6209-2Z	45*72*10	45*72*10
	6	Q3E180L6B	Alüminyum	347	689,0	2*M40	279	279	180	452	15	121	48	110	51,5	14	6310-2Z	6310-2Z	50*80*10	50*80*10
18,5	2	Q3E160L2C	Alüminyum	302	576,0	2*M32	254	254	160	360	15	108	42	110	45	12	6309-2Z	6209-2Z	45*72*10	45*72*10
	4	Q3E180M4B	Alüminyum	370	629,0	2*M40	241	279	180	428	15	121	48	110	51,5	14	6310-2Z	6310-2Z	50*80*10	50*80*10
	6	Q3E200L6C	Alüminyum	415	665,0	2*M50	305	318	200	461	19	133	55	110	59	16	6312-2Z	6312-2Z	60*90*10	60*90*10

BOYUTLAR / DIMENSIONS - B3

Güç Power (kW)	Kutup Sayısı Number of Poles	Motor Tipi Motor Type	Gövde Tipi Housing Type	Ana Boyutlar Main Dimensions			Ayaklı Motorlar / Foot Mounted Motors						Mil / Shaft				Rulman / Bearing		Keçe / Seal	
				AC	L	O	B	A	H	HD	K	C	D ⁽¹⁾	E	GA	F ⁽²⁾	Kasnak Tarafı Drive Side	Kasnak Tarafı Aksi Non Drive Side	Kasnak Tarafı Drive Side	Kasnak Tarafı Aksi Non Drive Side
22,0	2	Q3E160L2D	Alüminyum	302	576,0	2*M32	210	254	160	360	15	108	42	110	45	12	6309-2Z	6209-2Z	45*72*10	45*72*10
	2	Q3E180M2A	Alüminyum	370	629,0	2*M40	241	279	180	428	15	121	48	110	51,5	14	6310-2Z	6310-2Z	50*80*10	50*80*10
	4	Q3E180L4B	Alüminyum	370	629,0	2*M40	279	279	180	428	15	121	48	110	51,5	14	6310-2Z	6310-2Z	50*80*10	50*80*10
30,0	6	Q3E200L6D	Alüminyum	415	665,0	2*M50	305	318	200	461	19	133	55	110	59	16	6312-2Z	6312-2Z	60*90*10	60*90*10
	2	Q3E200L2B	Alüminyum	415	665,0	2*M50	305	318	200	461	19	133	55	110	59	16	6312-2Z	6310-2Z	60*90*10	50*80*10
	4	Q3E200L4D	Alüminyum	415	665,0	2*M50	311	318	200	461	19	133	55	110	59	16	6312-2Z	6310-2Z	60*90*10	50*80*10
37,0	6	Q3E225M6C	Alüminyum	456	765,0	2*M40	311	356	225	485	19	149	60	140	64	18	6313-2Z	6313-2Z	65*100*13	65*100*13
	2	Q3E200L2C	Alüminyum	415	665,0	2*M50	305	318	200	461	19	133	55	110	59	16	6312-2Z	6310-2Z	60*90*10	50*80*10
	4	Q3E225M4C	Alüminyum	456	765,0	2*M50	286	356	225	504	19	149	60	140	64	18	6313-2Z	6313-2Z	65*100*13	65*100*13
45,0	2	Q3E225M2B	Alüminyum	456	735,0	2*M50	311	356	225	504	19	149	55	110	59	16	6313-2Z	6313-2Z	65*100*13	65*100*13
	4	Q3E225M4D	Alüminyum	456	765,0	2*M50	311	356	225	504	19	149	60	140	64	18	6313-2Z	6313-2Z	65*100*13	65*100*13
	2	Q3E225M2C	Pik	527	886,0	2*M50	349	406	250	615	24	168	60	140	64	18	6316	6316	80*100*10	80*100*10
55,0	4	Q3EP250M4E	Pik	527	886,0	2*M50	349	406	250	615	24	168	65	140	69	18	6316	6316	80*100*10	80*100*10
	2	Q3EP280M2C	Pik	527	1025,0	2*M50	419	457	280	647	24	190	65	140	69	18	6316	6316	80*100*10	80*100*10
	4	Q3EP280M4C	Pik	527	1025,0	2*M50	419	457	280	647	24	190	75	140	80	20	6316	6316	80*100*10	80*100*10
75,0	2	Q3EP280M2D	Pik	527	1025,0	2*M50	419	457	280	647	24	190	65	140	69	18	6316	6316	80*100*10	80*100*10
	4	Q3EP280M4D	Pik	527	1025,0	2*M50	419	457	280	647	24	190	75	140	80	20	6316	6316	80*100*10	80*100*10
	2	Q3EP315S2C	Pik	652	1176,0	2*M63	406	508	315	833	28	216	65	140	69	18	6316	6316	80*100*5,5	80*100*5,5
90,0	4	Q3EP315S4C	Pik	652	1206,0	2*M63	406	508	315	833	28	216	80	170	85	22	6319	6319	95*115*5,5	95*115*5,5
	2	Q3EP315M2B	Pik	652	1176,0	2*M63	457	508	315	833	28	216	65	140	69	18	6316	6316	80*100*5,5	80*100*5,5
	4	Q3EP315M4B	Pik	652	1206,0	2*M63	457	508	315	833	28	216	80	170	85	22	6319	6319	95*115*5,5	95*115*5,5
110,0	2	Q3EP315L2A	Pik	652	1287,0	2*M63	508	508	315	833	28	216	65	140	69	18	6316	6316	80*100*5,5	80*100*5,5
	4	Q3EP315L4A	Pik	652	1317,0	2*M63	508	508	315	833	28	216	80	170	85	22	6319	6319	95*115*5,5	95*115*5,5
	2	Q3EP315L2C	Pik	652	1287,0	2*M63	508	508	315	833	28	216	65	140	69	18	6316	6316	80*100*5,5	80*100*5,5
132,0	4	Q3EP315L4C	Pik	652	1317,0	2*M63	508	508	315	833	28	216	80	170	85	22	6319	6319	95*115*5,5	95*115*5,5
	2	Q3EP355M2C	Pik	762	1512,0	4*M63	560	610	355	997	28	254	75	140	80	20	6317	6317	85*105*5,5	85*105*5,5
	4	Q3EP355M4C	Pik	762	1542,0	4*M63	560	610	355	997	28	254	95	170	100	25	6322	6322	110*130*5,5	110*130*5,5
160,0	2	Q3EP355L2B	Pik	762	1512,0	4*M63	630	610	355	997	28	254	75	140	80	20	6317	6317	85*105*5,5	85*105*5,5
	4	Q3EP355L4B	Pik	762	1542,0	4*M63	630	610	355	997	28	254	95	170	100	25	6322	6322	110*130*5,5	110*130*5,5
	2	Q3EP355L2C	Pik	762	1512,0	4*M63	630	610	355	997	28	254	75	140	80	20	6317	6317	85*105*5,5	85*105*5,5
200,0	4	Q3EP355L4C	Pik	762	1542,0	4*M63	630	610	355	997	28	254	95	170	100	25	6322	6322	110*130*5,5	110*130*5,5
	2	Q3EP355M2C	Pik	762	1512,0	4*M63	560	610	355	997	28	254	75	140	80	20	6317	6317	85*105*5,5	85*105*5,5
	4	Q3EP355M4C	Pik	762	1542,0	4*M63	560	610	355	997	28	254	95	170	100	25	6322	6322	110*130*5,5	110*130*5,5
250,0	2	Q3EP355L2B	Pik	762	1512,0	4*M63	630	610	355	997	28	254	75	140	80	20	6317	6317	85*105*5,5	85*105*5,5
	4	Q3EP355L4B	Pik	762	1542,0	4*M63	630	610	355	997	28	254	95	170	100	25	6322	6322	110*130*5,5	110*130*5,5
	2	Q3EP355L2C	Pik	762	1512,0	4*M63	630	610	355	997	28	254	75	140	80	20	6317	6317	85*105*5,5	85*105*5,5
315,0	4	Q3EP355L4C	Pik	762	1542,0	4*M63	630	610	355	997	28	254	95	170	100	25	6322	6322	110*130*5,5	110*130*5,5
	2	Q3EP355L2C	Pik	762	1512,0	4*M63	630	610	355	997	28	254	75	140	80	20	6317	6317	85*105*5,5	85*105*5,5
	4	Q3EP355L4C	Pik	762	1542,0	4*M63	630	610	355	997	28	254	95	170	100	25	6322	6322	110*130*5,5	110*130*5,5
355,0	2	Q3EP355L2C	Pik	762	1512,0	4*M63	630	610	355	997	28	254	75	140	80	20	6317	6317	85*105*5,5	85*105*5,5
	4	Q3EP355L4C	Pik	762	1542,0	4*M63	630	610	355	997	28	254	95	170	100	25	6322	6322	110*130*5,5	110*130*5,5

BOYUTLAR / DIMENSIONS - B5, B35

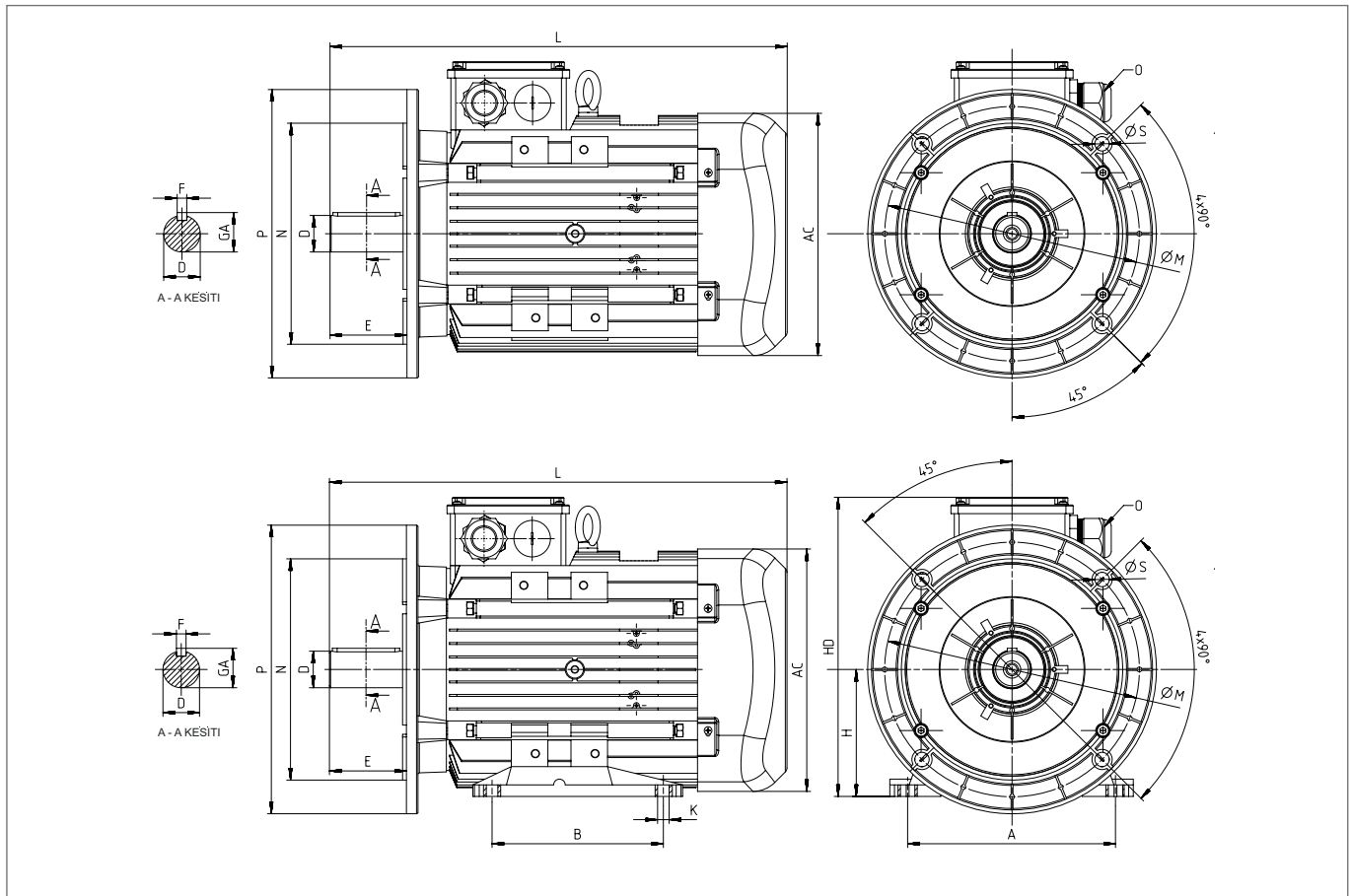

Güç Power (kW)	Kutup Sayısı Number of Poles	Motor Tipi Motor Type	Gövde Tipi Housing Type	Ana Boyutlar Main Dimensions			Ayaklı Motorlar Foot Mounted Motors					Mil / Shaft			Rulman / Bearing		Keçe / Seal		Flanş / Flange (FA) (B5)					
				AC	L	O	B	A	H	HD	K	D ⁽¹⁾	E	GA	F ⁽²⁾	Kasnak Tarafı Drive Side	Kasnak Tarafı Aksil Non Drive Side	Kasnak Tarafı Drive Side	Kasnak Tarafı Aksil Non Drive Side	P	N ⁽³⁾	M	R	S
0,75	2	Q3E80M2C	Alüminyum	158	283,5	1*M20	100	125	80	195	10	19	40	21,5	6	6204-2Z	6204-2Z	20*30*7	20*30*7	200	130	165	0	12
	4	Q3E80M4D	Alüminyum	158	283,5	1*M20	100	125	80	195	10	19	40	21,5	6	6204-2Z	6204-2Z	20*30*7	20*30*7	200	130	165	0	12
	6	Q3E90L6C	Alüminyum	193	316,5	1*M25	125	140	90	222	10	24	50	27	8	6305-2Z	6205-2Z	25*40*7	25*40*7	200	130	165	0	12
1,1	2	Q3E80M2D	Alüminyum	158	283,5	1*M20	100	125	80	195	10	19	40	21,5	6	6204-2Z	6204-2Z	20*30*7	20*30*7	200	130	165	0	12
	4	Q3E90L4C	Alüminyum	193	316,5	1*M25	100	140	90	222	10	24	50	27	8	6305-2Z	6205-2Z	25*40*7	25*40*7	200	130	165	0	12
	6	Q3E90L6D	Alüminyum	193	344,5	1*M25	125	140	90	222	10	24	50	27	8	6305-2Z	6205-2Z	25*40*7	25*40*7	200	130	165	0	12
1,5	2	Q3E90L2C	Alüminyum	193	316,5	1*M25	100	140	90	222	10	24	50	27	8	6305-2Z	6205-2Z	25*40*7	25*40*7	200	130	165	0	12
	4	Q3E90L4D	Alüminyum	193	344,5	1*M25	125	140	90	222	10	24	50	27	8	6305-2Z	6205-2Z	25*40*7	25*40*7	200	130	165	0	12
	6	Q3E100L6D	Alüminyum	217	352,0	1*M25	140	160	100	241	12	28	60	31	8	6306-2Z	6205-2Z	30*47*7	25*47*7	250	180	215	0	15
2,2	2	Q3E90L2D	Alüminyum	193	316,5	1*M25	125	140	90	222	10	24	50	27	8	6305-2Z	6205-2Z	25*40*7	25*40*7	200	130	165	0	12
	4	Q3E100L4C	Alüminyum	217	352,0	1*M25	140	160	100	241	12	28	60	31	8	6306-2Z	6205-2Z	30*47*7	25*40*7	250	180	215	0	15
	6	Q3E112M6D	Alüminyum	232	395,5	2*M25	140	190	112	261	12	28	60	31	8	6306-2Z	6206-2Z	30*47*7	30*47*7	250	180	215	0	15
3,0	2	Q3E100L2C	Alüminyum	217	352,0	1*M25	140	160	100	241	12	28	60	31	8	6306-2Z	6205-2Z	30*47*7	25*40*7	250	180	215	0	15
	4	Q3E100L4D	Alüminyum	217	377,0	1*M25	140	160	100	241	12	28	60	31	8	6306-2Z	6205-2Z	30*47*7	25*40*7	250	180	215	0	15
	6	Q3E132M6B	Alüminyum	260	481,0	2*M32	178	216	132	323	12	38	80	41	10	6208-2Z	6208-2Z	40*62*10	40*62*10	300	230	265	0	15
4,0	2	Q3E112M2C	Alüminyum	232	395,5	2*M25	140	190	112	261	12	28	60	31	8	6306-2Z	6206-2Z	30*47*7	30*47*7	250	180	215	0	15
	4	Q3E112M4C	Alüminyum	232	395,5	2*M25	140	190	112	261	12	28	60	31	8	6306-2Z	6206-2Z	30*47*7	30*47*7	250	180	215	0	15
	6	Q3E132M6C	Alüminyum	260	481,0	2*M32	178	216	132	323	12	38	80	41	10	6208-2Z	6208-2Z	40*62*10	40*62*10	300	230	265	0	15
5,5	2	Q3E132S2C	Alüminyum	279	440,5	2*M32	140	216	132	314	12	38	80	41	10	6208-2Z	6208-2Z	40*62*10	40*62*10	300	230	265	0	15
	4	Q3E132M4B	Alüminyum	279	475,5	2*M32	140	216	132	314	12	38	80	41	10	6208-2Z	6208-2Z	40*62*10	40*62*10	300	230	265	0	15
	6	Q3E132M6D	Alüminyum	260	481,0	2*M32	178	216	132	323	12	38	80	41	10	6208-2Z	6208-2Z	40*62*10	40*62*10	300	230	265	0	15
7,5	2	Q3E132M2A	Alüminyum	279	475,5	2*M32	140	216	132	314	12	38	80	41	10	6208-2Z	6208-2Z	40*62*10	40*62*10	300	230	265	0	15
	4	Q3E132M4C	Alüminyum	279	475,5	2*M32	178	216	132	314	12	38	80	41	10	6208-2Z	6208-2Z	40*62*10	40*62*10	300	230	265	0	15
	6	Q3E160L6C	Alüminyum	302	576,0	2*M32	254	254	160	360	15	42	110	45	12	6309-2Z	6209-2Z	45*72*10	45*72*10	350	250	300	0	19
11,0	2	Q3E160L2A	Alüminyum	302	576,0	2*M32	254	254	160	360	15	42	110	45	12	6309-2Z	6209-2Z	45*72*10	45*72*10	350	250	300	0	19
	4	Q3E160L4A	Alüminyum	302	576,0	2*M32	254	254	160	360	15	42	110	45	12	6309-2Z	6209-2Z	45*72*10	45*72*10	350	250	300	0	19
	6	Q3E160L6D	Alüminyum	302	576,0	2*M32	254	254	160	360	15	42	110	45	12	6309-2Z	6209-2Z	45*72*10	45*72*10	350	250	300	0	19

BOYUTLAR / DIMENSIONS - B5, B35

Güç Power (kW)	Kutup Sayısı Number of Poles	Motor Tipi Motor Type	Gövde Tipi Housing Type	Ana Boyutlar Main Dimensions			Ayaklı Motorlar Foot Mounted Motors					Mil / Shaft				Rulman / Bearing		Keçe / Seal		Flanş / Flange (FA) (B5)				
				AC	L	O	B	A	H	HD	K	D ⁽¹⁾	E	GA	F ⁽²⁾	Kasnak Tarafı Drive Side	Kasnak Tarafı Aksi Non Drive Side	Kasnak Tarafı Drive Side	Kasnak Tarafı Aksi Non Drive Side	P	N ⁽³⁾	M	R	S
15,0	2	Q3E160L2C	Alüminyum	302	576,0	2*M32	254	254	160	360	15	42	110	45	12	6309-2Z	6209-2Z	45*72*10	45*72*10	350	250	300	0	19
	4	Q3E160L4B	Alüminyum	302	576,0	2*M32	254	254	160	360	15	42	110	45	12	6309-2Z	6209-2Z	45*72*10	45*72*10	350	250	300	0	19
	6	Q3E180L6B	Alüminyum	347	689,0	2*M40	279	279	180	452	15	48	110	51,5	14	6310-2Z	6310-2Z	50*80*10	50*80*10	350	250	300	0	19
18,5	2	Q3E160L2C	Alüminyum	302	576,0	2*M32	254	254	160	360	15	42	110	45	12	6309-2Z	6209-2Z	45*72*10	45*72*10	350	250	300	0	19
	4	Q3E180M4B	Alüminyum	370	629,0	2*M40	241	279	180	428	15	48	110	51,5	14	6310-2Z	6310-2Z	50*80*10	50*80*10	350	250	300	0	19
	6	Q3E200L6C	Alüminyum	415	665,0	2*M50	305	318	200	461	19	55	110	59	16	6312-2Z	6312-2Z	60*90*10	60*90*10	400	300	350	0	19
22,0	2	Q3E160L2D	Alüminyum	302	576,0	2*M32	210	254	160	360	15	42	110	45	12	6309-2Z	6209-2Z	45*72*10	45*72*10	350	250	300	0	19
	2	Q3E180M2A	Alüminyum	370	629,0	2*M40	241	279	180	428	15	48	110	51,5	14	6310-2Z	6310-2Z	50*80*10	50*80*10	350	250	300	0	19
	4	Q3E180L4B	Alüminyum	370	629,0	2*M40	279	279	180	428	15	48	110	51,5	14	6310-2Z	6310-2Z	50*80*10	50*80*10	350	250	300	0	19
30,0	2	Q3E200L2B	Alüminyum	415	665,0	2*M50	305	318	200	461	19	55	110	59	16	6312-2Z	6310-2Z	60*90*10	50*80*10	400	300	350	0	19
	4	Q3E200L4D	Alüminyum	415	665,0	2*M50	305	318	200	461	19	55	110	59	16	6312-2Z	6310-2Z	60*90*10	50*80*10	400	300	350	0	19
	6	Q3E225M6C	Alüminyum	456	765,0	2*M40	311	356	225	485	19	60	140	64	18	6313-2Z	6313-2Z	65*100*13	65*100*13	450	350	400	0	19
37,0	2	Q3E200L2C	Alüminyum	415	665,0	2*M50	305	318	200	461	19	55	110	59	16	6312-2Z	6310-2Z	60*90*10	50*80*10	400	300	350	0	19
	4	Q3E225M4C	Alüminyum	456	765,0	2*M50	286	356	225	504	19	60	140	64	18	6313-2Z	6313-2Z	65*100*13	65*100*13	450	350	400	0	19
45,0	2	Q3E225M2B	Alüminyum	456	735,0	2*M50	311	356	225	504	19	55	110	59	16	6313-2Z	6313-2Z	65*100*13	65*100*13	450	350	400	0	19
	4	Q3E225M4D	Alüminyum	456	765,0	2*M50	311	356	225	504	19	60	140	64	18	6313-2Z	6313-2Z	65*100*13	65*100*13	450	350	400	0	19
55,0	2	Q3EP250M2C	Pik	527	886,0	2*M50	349	406	250	615	24	60	140	64	18	6316	6316	80*100*10	80*100*10	550	450	500	0	19
	4	Q3EP250M4E	Pik	527	886,0	2*M50	349	406	250	615	24	65	140	69	18	6316	6316	80*100*10	80*100*10	550	450	500	0	19
75,0	2	Q3EP280M2C	Pik	527	1025,0	2*M50	419	457	280	647	24	65	140	69	18	6316	6316	80*100*10	80*100*10	550	450	500	0	19
	4	Q3EP280M4C	Pik	527	1025,0	2*M50	419	457	280	647	24	75	140	80	20	6316	6316	80*100*10	80*100*10	550	450	500	0	19
90,0	4	Q3EP280M2D	Pik	527	1025,0	2*M50	419	457	280	647	24	65	140	69	18	6316	6316	80*100*10	80*100*10	550	450	500	0	19
	4	Q3EP280M4D	Pik	527	1025,0	2*M50	419	457	280	647	24	75	140	80	20	6316	6316	80*100*10	80*100*10	550	450	500	0	19
110,0	2	Q3EP315S2C	Pik	652	1176,0	2*M63	406	508	315	833	28	65	140	69	18	6316	6316	80*100*5,5	80*100*5,5	660	550	600	0	24
	4	Q3EP315S4C	Pik	652	1206,0	2*M63	406	508	315	833	28	80	170	85	22	6319	6319	95*115*5,5	95*115*5,5	660	550	600	0	24
132,0	2	Q3EP315M2B	Pik	652	1176,0	2*M63	457	508	315	833	28	65	140	69	18	6316	6316	80*100*5,5	80*100*5,5	660	550	600	0	24
	4	Q3EP315M4B	Pik	652	1206,0	2*M63	457	508	315	833	28	80	170	85	22	6319	6319	95*115*5,5	95*115*5,5	660	550	600	0	24
160,0	2	Q3EP315L2A	Pik	652	1287,0	2*M63	508	508	315	833	28	65	140	69	18	6316	6316	80*100*5,5	80*100*5,5	660	550	600	0	24
	4	Q3EP315L4A	Pik	652	1317,0	2*M63	508	508	315	833	28	80	170	85	22	6319	6319	95*115*5,5	95*115*5,5	660	550	600	0	24
200,0	2	Q3EP315L2C	Pik	652	1287,0	2*M63	508	508	315	833	28	65	140	69	18	6316	6316	80*100*5,5	80*100*5,5	660	550	600	0	24
	4	Q3EP315L4C	Pik	652	1317,0	2*M63	508	508	315	833	28	80	170	85	22	6319	6319	95*115*5,5	95*115*5,5	660	550	600	0	24
250,0	2	Q3EP355M2C	Pik	762	1512,0	4*M63	560	610	355	997	28	75	140	80	20	6317	6317	85*105*5,5	85*105*5,5	800	680	740	0	24
	4	Q3EP355M4C	Pik	762	1542,0	4*M63	560	610	355	997	28	95	170	100	25	6322	6322	110*130*5,5	110*130*5,5	800	680	740	0	24
315,0	2	Q3EP355L2B	Pik	762	1512,0	4*M63	630	610	355	997	28	75	140	80	20	6317	6317	85*105*5,5	85*105*5,5	800	680	740	0	24
	4	Q3EP355L4B	Pik	762	1542,0	4*M63	630	610	355	997	28	95	170	100	25	6322	6322	110*130*5,5	110*130*5,5	800	680	740	0	24
355,0	2	Q3EP355L2C	Pik	762	1512,0	4*M63	630	610	355	997	28	75	140	80	20	6317	6317	85*105*5,5	85*105*5,5	800	680	740	0	24
	4	Q3EP355L4C	Pik	762	1542,0	4*M63	630	610	355	997	28	95	170	100	25	6322	6322	110*130*5,5	110*130*5,5	800	680	740	0	24

BOYUTLAR / DIMENSIONS - B14a, B34a

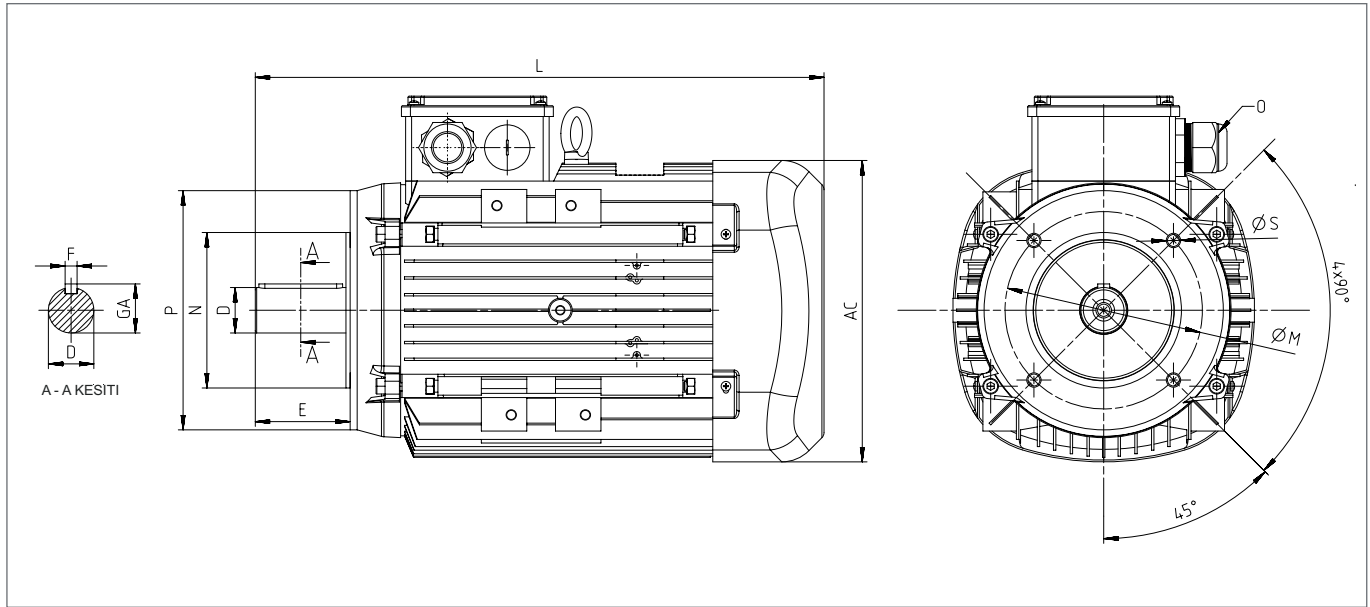

Güç Power (kW)	Kutup Sayısı Number of Poles	Motor Tipi Motor Type	Gövde Tipi Housing Type	Ana Boyutlar Main Dimensions			Ayaklı Motorlar Foot Mounted Motors							Mil / Shaft				Rulman / Bearing		Keçe / Seal		Flanş / Flange (FC) (B14a)				
				AC	L	O	B	A	H	HD	K	D ⁽¹⁾	E	GA	F ⁽²⁾	Kasnak Tarafı Drive Side	Kasnak Tarafı Aksil Non Drive Side	Kasnak Tarafı Drive Side	Kasnak Tarafı Aksil Non Drive Side	P	N ⁽³⁾	M	R	S		
0,75	2	Q3E80M2C	Alüminyum	158	283,5	1*M20	100	125	80	195	10	19	40	21,5	6	6204-2Z	6204-2Z	20*30*7	20*30*7	120	80	100	0	M6		
	4	Q3E80M4D	Alüminyum	158	283,5	1*M20	100	125	80	195	10	19	40	21,5	6	6204-2Z	6204-2Z	20*30*7	20*30*7	120	80	100	0	M6		
	6	Q3E90L6C	Alüminyum	193	316,5	1*M25	125	140	90	222	10	24	50	27	8	6305-2Z	6205-2Z	25*40*7	25*40*7	200	130	165	0	12		
1,1	2	Q3E80M2D	Alüminyum	158	283,5	1*M20	100	125	80	195	10	19	40	21,5	6	6204-2Z	6204-2Z	20*30*7	20*30*7	120	80	100	0	M6		
	4	Q3E90L4C	Alüminyum	193	316,5	1*M25	100	140	90	222	10	24	50	27	8	6305-2Z	6205-2Z	25*40*7	25*40*7	140	95	115	0	M8		
	6	Q3E90L6D	Alüminyum	193	344,5	1*M25	125	140	90	222	10	24	50	27	8	6305-2Z	6205-2Z	25*40*7	25*40*7	200	130	165	0	12		
1,5	2	Q3E90L2C	Alüminyum	193	316,5	1*M25	100	140	90	222	10	24	50	27	8	6305-2Z	6205-2Z	25*40*7	25*40*7	140	95	115	0	M8		
	4	Q3E90L4D	Alüminyum	193	344,5	1*M25	125	140	90	222	10	24	50	27	8	6305-2Z	6205-2Z	25*40*7	25*40*7	140	95	115	0	M8		
	6	Q3E100L6D	Alüminyum	217	352,0	1*M25	140	160	100	241	12	28	60	31	8	6306-2Z	6205-2Z	30*47*7	25*47*7	250	180	215	0	15		
2,2	2	Q3E90L2D	Alüminyum	193	316,5	1*M25	125	140	90	222	10	24	50	27	8	6305-2Z	6205-2Z	25*40*7	25*40*7	140	95	115	0	M8		
	4	Q3E100L4C	Alüminyum	217	352,0	1*M25	140	160	100	241	12	28	60	31	8	6306-2Z	6205-2Z	30*47*7	25*40*7	160	110	130	0	M8		
	6	Q3E112M6D	Alüminyum	232	395,5	2*M25	140	190	112	261	12	28	60	31	8	6306-2Z	6206-2Z	30*47*7	30*47*7	250	180	215	0	15		
3,0	2	Q3E100L2C	Alüminyum	217	352,0	1*M25	140	160	100	241	12	28	60	31	8	6306-2Z	6205-2Z	30*47*7	25*40*7	160	110	130	0	M8		
	4	Q3E100L4D	Alüminyum	217	377,0	1*M25	140	160	100	241	12	28	60	31	8	6306-2Z	6205-2Z	30*47*7	25*40*7	160	110	130	0	M8		
	6	Q3E132M6B	Alüminyum	260	481,0	2*M32	178	216	132	323	12	38	80	41	10	6208-2Z	6208-2Z	40*62*10	40*62*10	300	230	265	0	15		
4,0	2	Q3E112M2C	Alüminyum	232	395,5	2*M25	140	190	112	261	12	28	60	31	8	6306-2Z	6206-2Z	30*47*7	30*47*7	160	110	130	0	M8		
	4	Q3E112M4C	Alüminyum	232	395,5	2*M25	140	190	112	261	12	28	60	31	8	6306-2Z	6206-2Z	30*47*7	30*47*7	160	110	130	0	M8		
	6	Q3E132M6C	Alüminyum	260	481,0	2*M32	178	216	132	323	12	38	80	41	10	6208-2Z	6208-2Z	40*62*10	40*62*10	300	230	265	0	15		
5,5	2	Q3E132S2C	Alüminyum	279	440,5	2*M32	140	216	132	314	12	38	80	41	10	6208-2Z	6208-2Z	40*62*10	40*62*10	200	130	165	0	M10		
	4	Q3E132M4B	Alüminyum	279	475,5	2*M32	140	216	132	314	12	38	80	41	10	6208-2Z	6208-2Z	40*62*10	40*62*10	200	130	165	0	M10		
	6	Q3E132M6D	Alüminyum	260	481,0	2*M32	178	216	132	323	12	38	80	41	10	6208-2Z	6208-2Z	40*62*10	40*62*10	300	230	265	0	15		
7,5	2	Q3E132M2A	Alüminyum	279	475,5	2*M32	140	216	132	314	12	38	80	41	10	6208-2Z	6208-2Z	40*62*10	40*62*10	200	130	165	0	M10		
	4	Q3E132M4C	Alüminyum	279	475,5	2*M32	178	216	132	314	12	38	80	41	10	6208-2Z	6208-2Z	40*62*10	40*62*10	200	130	165	0	M10		

BOYUTLAR / DIMENSIONS - B14b, B34b

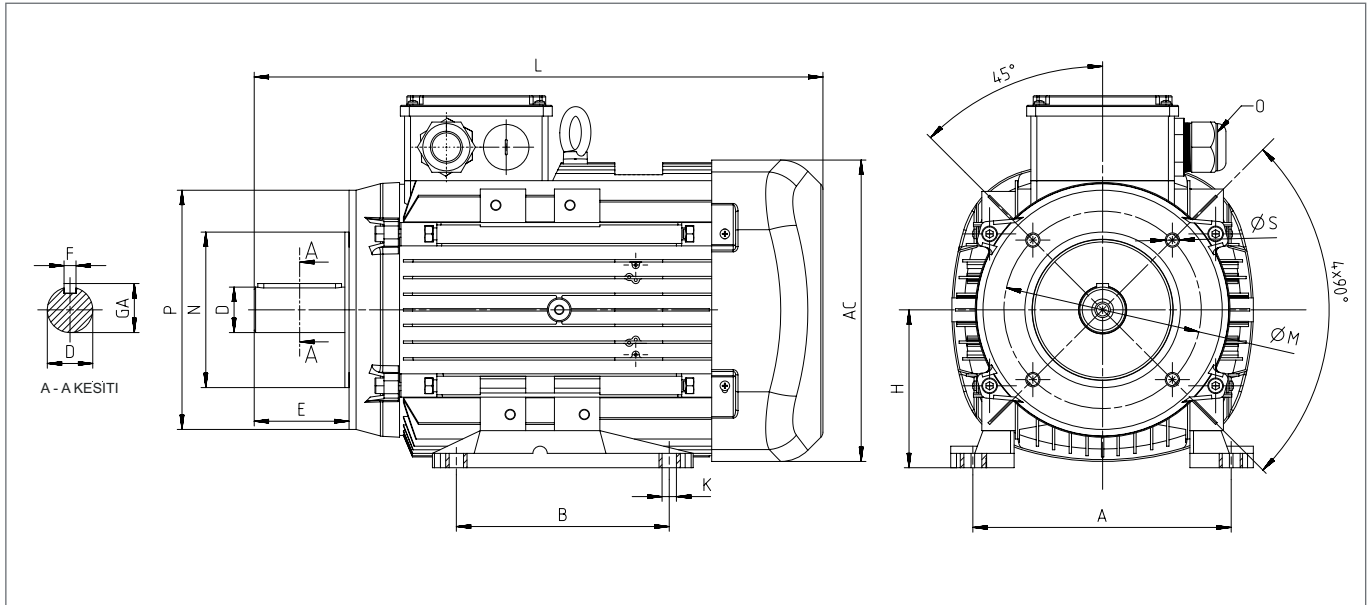

Güç Power (kW)	Kutup Sayısı Number of Poles	Motor Tipi Motor Type	Gövde Tipi Housing Type	Ana Boyutlar Main Dimensions			Ayaklı Motorlar Foot Mounted Motors						Mil / Shaft				Rulman / Bearing		Keçe / Seal		Flanş / Flange (FB) (B14b)				
				AC	L	O	B	A	H	HD	K	D ⁽¹⁾	E	GA	F ⁽²⁾	Kasnak Tarafı Drive Side	Kasnak Tarafı Aksil Non Drive Side	Kasnak Tarafı Drive Side	Kasnak Tarafı Aksil Non Drive Side	P	N ⁽³⁾	M	R	S	
0,75	2	Q3E80M2C	Alüminyum	158	283,5	1*M20	100	125	80	195	10	19	40	21,5	6	6204-2Z	6204-2Z	20*30*7	20*30*7	160	110	130	0	M8	
	4	Q3E80M4D	Alüminyum	158	283,5	1*M20	100	125	80	195	10	19	40	21,5	6	6204-2Z	6204-2Z	20*30*7	20*30*7	160	110	130	0	M8	
	6	Q3E90L6C	Alüminyum	193	316,5	1*M25	125	140	90	222	10	24	50	27	8	6305-2Z	6205-2Z	25*40*7	25*40*7	200	130	165	0	12	
1,1	2	Q3E80M2D	Alüminyum	158	283,5	1*M20	100	125	80	195	10	19	40	21,5	6	6204-2Z	6204-2Z	20*30*7	20*30*7	160	110	130	0	M8	
	4	Q3E90L4C	Alüminyum	193	316,5	1*M25	100	140	90	222	10	24	50	27	8	6305-2Z	6205-2Z	25*40*7	25*40*7	160	110	130	0	M8	
	6	Q3E90L6D	Alüminyum	193	344,5	1*M25	125	140	90	222	10	24	50	27	8	6305-2Z	6205-2Z	25*40*7	25*40*7	200	130	165	0	12	
1,5	2	Q3E90L2C	Alüminyum	193	316,5	1*M25	100	140	90	222	10	24	50	27	8	6305-2Z	6205-2Z	25*40*7	25*40*7	160	110	130	0	M8	
	4	Q3E90L4D	Alüminyum	193	344,5	1*M25	125	140	90	222	10	24	50	27	8	6305-2Z	6205-2Z	25*40*7	25*40*7	160	110	130	0	M8	
	6	Q3E100L6D	Alüminyum	217	352,0	1*M25	140	160	100	241	12	28	60	31	8	6306-2Z	6205-2Z	30*47*7	25*47*7	250	180	215	0	15	
2,2	2	Q3E90L2D	Alüminyum	193	316,5	1*M25	125	140	90	222	10	24	50	27	8	6305-2Z	6205-2Z	25*40*7	25*40*7	160	110	130	0	M8	
	4	Q3E100L4C	Alüminyum	217	352,0	1*M25	140	160	100	241	12	28	60	31	8	6306-2Z	6205-2Z	30*47*7	25*40*7	200	130	165	0	M10	
	6	Q3E112M6D	Alüminyum	232	395,5	2*M25	140	190	112	261	12	28	60	31	8	6306-2Z	6206-2Z	30*47*7	30*47*7	250	180	215	0	15	
3,0	2	Q3E100L2C	Alüminyum	217	352,0	1*M25	140	160	100	241	12	28	60	31	8	6306-2Z	6205-2Z	30*47*7	25*40*7	200	130	165	0	M10	
	4	Q3E100L4D	Alüminyum	217	377,0	1*M25	140	160	100	241	12	28	60	31	8	6306-2Z	6205-2Z	30*47*7	25*40*7	200	130	165	0	M10	
	6	Q3E132M6B	Alüminyum	260	481,0	2*M32	178	216	132	323	12	38	80	41	10	6208-2Z	6208-2Z	40*62*10	40*62*10	300	230	265	0	15	
4,0	2	Q3E112M2C	Alüminyum	232	395,5	2*M25	140	190	112	261	12	28	60	31	8	6306-2Z	6206-2Z	30*47*7	30*47*7	200	130	165	0	M10	
	4	Q3E112M4C	Alüminyum	232	395,5	2*M25	140	190	112	261	12	28	60	31	8	6306-2Z	6206-2Z	30*47*7	30*47*7	200	130	165	0	M10	
	6	Q3E132M6C	Alüminyum	260	481,0	2*M32	178	216	132	323	12	38	80	41	10	6208-2Z	6208-2Z	40*62*10	40*62*10	300	230	265	0	15	
5,5	2	Q3E132S2C	Alüminyum	279	440,5	2*M32	140	216	132	314	12	38	80	41	10	6208-2Z	6208-2Z	40*62*10	40*62*10	250	180	215	0	M12 veya 15	
	4	Q3E132M4B	Alüminyum	279	475,5	2*M32	140	216	132	314	12	38	80	41	10	6208-2Z	6208-2Z	40*62*10	40*62*10	250	180	215	0	M12 veya 15	
	6	Q3E132M6D	Alüminyum	260	481,0	2*M32	178	216	132	323	12	38	80	41	10	6208-2Z	6208-2Z	40*62*10	40*62*10	300	230	265	0	15	
7,5	2	Q3E132M2A	Alüminyum	279	475,5	2*M32	140	216	132	314	12	38	80	41	10	6208-2Z	6208-2Z	40*62*10	40*62*10	250	180	215	0	M12 veya 15	
	4	Q3E132M4C	Alüminyum	279	475,5	2*M32	178	216	132	314	12	38	80	41	10	6208-2Z	6208-2Z	40*62*10	40*62*10	250	180	215	0	M12 veya 15	

ELEKTRİKSEL ÖZELLİKLER - 50 Hz / ELECTRICAL CHARACTERISTICS AT 50 Hz

Motor Tipi Motor Type	Gövde Tipi Housing Type	Nominal / Rated Values					Kalkıştaki Değerler / Starting Values					Devirline Moment Oranı Brake/Down Torque Ratio Mk/Mn	Verim * Efficiency*			Cos φ	J kgm ²	Ağırlık (B3) Weight (B3) kg	Ses Seviyesi dB(A)** Sound Pressure Level dB(A)**
		Güç / Power kW	HP	Devir Speed d/d	Akım Current A	Moment Torque Nm	Akım Current I _A / A _N	Moment Torque M _A / M _N	η%	4/4	3/4		2/4						
2kutup3000d/d																			
220/380V	Q2E71M2C*	Alüminyum	0,37	1/2	2850	1,0	1,2	7,7	-	3,6	-	3,8	69,5	69,6	67,3	0,80	0,00067	8	54
	Q2E71M2D*	Alüminyum	0,55	3/4	2860	1,2	1,8	7,8	-	3,7	-	3,9	74,1	74,2	72,0	0,82	0,00086	9,7	54
	Q2E80M2B	Alüminyum	0,75	1,0	2860	1,7	2,5	7,7	-	3,7	-	4,0	77,4	77,0	73,6	0,84	0,00109	11	58
	Q2E80M2D	Alüminyum	1,1	1,5	2860	2,4	3,6	7,7	-	3,7	-	4,1	79,6	79,1	77,1	0,84	0,00150	13	58
	Q2E90L2C	Alüminyum	1,5	2,0	2900	3,2	5,0	7,8	-	3,4	-	4,0	81,3	80,8	77,7	0,83	0,00182	17	62
	Q2E90L2D	Alüminyum	2,2	3,0	2900	4,7	7,3	7,9	-	3,5	-	4,1	83,2	82,9	80,5	0,84	0,00182	18	62
	Q2E100L2C	Alüminyum	3,0	4,0	2875	6,0	9,9	9,1	-	3,9	-	4,6	84,6	84,5	83,1	0,90	0,00335	21	64
380/660V	Q2E112M2C	Alüminyum	4,0	5,5	2900	7,7	13,2	2,9	8,6	1,3	3,8	4,5	85,8	85,7	84,3	0,88	0,00489	31	67
	Q2E132S2C	Alüminyum	5,5	7,5	2900	10,4	18,0	3,0	8,9	1,1	3,2	4,2	87,0	86,9	85,2	0,91	0,01410	46	70
	Q2E132M2A	Alüminyum	7,5	10,0	2920	13,6	24,5	2,9	8,6	1,0	3,0	3,7	88,1	87,7	85,9	0,90	0,01596	53	70
	Q2E160M2B	Alüminyum	11,0	15,0	2930	20,3	35,9	3,1	9,4	1,0	3,0	3,8	89,4	89,3	87,5	0,91	0,02644	76	71
	Q2E160L2A	Alüminyum	15,0	20,0	2930	27,0	48,7	2,9	8,6	1,0	3,0	3,3	90,3	90,2	88,4	0,93	0,03317	82	71
	Q2E160L2C	Alüminyum	18,5	25,0	2930	32,8	60,0	3,3	10,0	0,5	1,4	4,3	90,9	90,8	89,0	0,91	0,04075	90	71
	Q2E180M2A	Alüminyum	22,0	30,0	2945	38,7	71,3	2,6	7,9	0,7	2,2	3,4	91,3	90,9	89,5	0,91	0,06193	114	77
	Q2E200L2B	Alüminyum	30,0	40,0	2955	56,6	97,1	2,6	7,9	0,6	1,9	4,1	92,0	91,4	89,6	0,86	0,11917	167	80
	Q2E200L2C	Alüminyum	37,0	50,0	2955	66,8	119,4	2,8	8,3	0,6	1,9	3,1	92,5	91,9	90,1	0,91	0,15010	167	80
	Q2E225M2B	Alüminyum	45,0	60,0	2965	85,7	145,2	2,8	8,3	0,7	2,2	3,4	92,9	92,6	91,1	0,86	0,23505	235	81
	Q2EP250M2B	Pik	55,0	75,0	2970	97,9	178,5	1,7	5,1	0,7	2,1	3,1	93,2	92,1	90,9	0,91	0,48707	486	82
	Q2EP280M2B	Pik	75,0	100,0	2970	135,0	241,1	3,0	9,1	0,7	2,1	2,6	93,8	93,7	92,5	0,90	0,54033	576	84
	Q2EP280M2C	Pik	90,0	125,0	2970	156,5	291,3	3,3	10,0	1,1	3,2	3,6	94,1	93,9	92,9	0,93	0,64510	585	84
400/690V	Q2EP315S2C	Pik	110,0	127,0	2.975	185	353	2,6	7,8	0,7	2,2	2,4	94,3	94,3	93,1	0,91	1,43600	920	87
	Q2EP315M2C	Pik	132,0	152,0	2.975	221	423	2,6	7,8	0,8	2,3	2,4	94,6	94,6	93,4	0,91	1,72300	970	87
	Q2EP315L2C	Pik	160,0	184,0	2.975	268	513	2,5	7,5	0,8	2,3	2,4	94,8	94,8	93,6	0,91	1,95300	1.170	87
	Q2EP315L2D	Pik	200,0	230,0	2.975	334	643	2,7	8,0	0,8	2,4	2,6	95,0	95,0	93,8	0,91	2,52700	1.200	87
	Q2EP355M2C	Pik	250,0	280,0	2.985	422	799	2,3	7,0	0,7	2,0	2,4	95,0	95,0	93,8	0,90	3,92000	1.690	87
	Q2EP355L2C	Pik	315,0	353,0	2.985	532	1.007	2,5	7,4	0,7	2,0	2,3	95,0	95,0	93,8	0,90	4,17000	1.870	87
	Q2EP355L2D	Pik	355,0	398,0	2.985	599	1.135	2,5	7,5	0,6	1,8	2,1	95,0	95,0	93,8	0,90	4,44000	1.953	87
4kutup1500d/d																			
220/380V	Q2E71M4C*	Alüminyum	0,25	1/3	1415	0,7	1,7	4,4	-	2,3	-	3,4	68,5	68,8	68,8	0,74	0,00095	9	45
	Q2E71M4D*	Alüminyum	0,37	1/2	1415	1,1	2,5	4,4	-	2,3	-	3,4	72,7	73,1	72,0	0,75	0,00095	8,5	45
	Q2E80M4B*	Alüminyum	0,55	3/4	1415	1,5	3,7	4,8	-	2,8	-	3,2	77,1	77,6	76,4	0,76	0,00205	10,5	49
	Q2E80M4D	Alüminyum	0,75	1,0	1435	2	5,1	5,2	-	2,9	-	3,2	79,6	78,9	75,3	0,7	0,00268	12	49
	Q2E90L4C	Alüminyum	1,1	1,5	1430	2,5	7,4	6,7	-	2,9	-	3,3	81,4	80,8	78,1	0,81	0,00365	18	54
	Q2E90L4D	Alüminyum	1,5	2,0	1430	3,5	10,0	7,0	-	3,2	-	3,6	82,8	82,0	79,3	0,76	0,00365	18	55
	Q2E100L4C	Alüminyum	2,2	3,0	1430	5,0	14,6	7,1	-	3,9	-	4,2	84,3	83,8	81,2	0,77	0,00545	26	56
	Q2E100L4D	Alüminyum	3,0	4,0	1440	6,4	20,0	7,1	-	3,4	-	3,8	85,5	85,1	83,0	0,75	0,00581	26	56
380/660V	Q2E112M4C	Alüminyum	4,0	5,5	1440	8,7	26,3	2,6	7,9	0,9	2,8	3,9	86,6	86,0	84,5	0,81	0,01123	31	58
	Q2E132M4B	Alüminyum	5,5	7,5	1450	11,7	36,2	2,4	7,1	1,1	3,2	3,9	87,7	87,6	85,2	0,81	0,02763	54	61
	Q2E132M4C	Alüminyum	7,5	10,0	1450	15,8	49,4	2,9	8,7	0,9	2,8	4,1	88,7	88,5	86,6	0,80	0,02980	57	61
	Q2E160M4B	Alüminyum	11,0	15,0	1460	22,5	72,5	2,0	6,0	0,7	2,2	2,7	89,8	89,7	88,2	0,83	0,05547	76	63
	Q2E160L4A	Alüminyum	15,0	20,0	1460	28,8	98,5	2,0	6,0	0,8	2,3	2,7	90,6	90,5	89,5	0,83	0,06922	92	63
	Q2E180M4B	Alüminyum	18,5	25,0	1465	36,5	121,4	2,5	7,4	1,0	3,0	4,1	91,2	91,1	90,2	0,84	0,11220	119	69
	Q2E180L4B	Alüminyum	22,0	30,0	1465	44,5	143,5	2,6	7,7	0,8	2,4	3,4	91,6	91,5	90,6	0,82	0,12773	127	69
	Q2E200L4D	Alüminyum	30,0	40,0	1465	57,3	195,6	2,4	7,3	0,8	2,5	3,2	92,3	92,1	91,1	0,86	0,26448	177	70
	Q2E225M4C	Alüminyum	37,0	50,0	1480	70,7	240,0	2,5	7,5	1,0	2,9	3,5	92,7	92,6	91,5	0,84	0,36429	260	71
	Q2E225M4D	Alüminyum	45,0	60,0	1470	85,9	292,3	2,6	7,7	1,0	2,9	3,5	93,1	93,0	91,9	0,85	0,43513	280	71
	Q2EP250M4D	Pik	55,0	75,0	1480	105,0	359,0	2,4	7,1	0,7	2,1	2,9	93,5	93,2	90,7	0,83	0,90782	506	72
	Q2EP280M4B	Pik	75,0	100,0	1475	147,0	485,7	2,5	7,4	0,7	2,1	3,1	94,0	93,9	93,2	0,85	1,06114	624	73
	Q2EP280M4C	Pik	90,0	125,0	1470	173,8	584,2	2,5	7,4	0,7	2,1	3,0	94,2	94,4	93,6	0,85	1,14768	638	73

ELEKTRİKSEL ÖZELLİKLER - 50 Hz / ELECTRICAL CHARACTERISTICS AT 50 Hz

Motor Tipi Motor Type	Gövde Tipi Housing Type	Nominal / Rated Values					Kalkıştaki Değerler / Starting Values					Devirline Moment / Oran Brakedown Torque Ratio Mk/Mn	Verim * Efficiency*			Cos φ	J kgm ²	Ağırlık (B3) Weight (B3) kg	Ses Seviyesi dB(A)** Sound Pressure Level dB(A)**
		Güç / Power kW HP	Devir Speed d/d	Akım Current A	Moment Torque Nm	Akım Current I _A / A _N	Moment Torque M _A / M _N	η %	4/4	3/4	2/4								
4kutup1500d/d																			
400/690V	Q2EP315S4C	Pik	110,0	127,0	1.480	191	709	2,4	7,2	0,7	2,2	2,5	94,5	94,5	93,9	0,88	3,03500	925	70
	Q2EP315M4C	Pik	132,0	152,0	1.480	229	851	2,3	7,0	0,7	2,1	2,4	94,7	94,7	94,1	0,88	3,41500	1.010	70
	Q2EP315L4C	Pik	160,0	184,0	1.480	273	1.032	2,5	7,5	0,7	2,2	2,5	94,9	94,9	94,3	0,89	4,11900	1.080	76
	Q2EP315L4D	Pik	200,0	230,0	1.480	341	1.290	2,5	7,5	0,8	2,3	2,5	95,1	95,1	94,5	0,89	5,20300	1.200	76
	Q2EP355M4C	Pik	250,0	280,0	1.485	426	1.607	2,6	7,9	0,8	2,3	2,5	95,1	95,1	94,5	0,89	8,79000	1.720	76
	Q2EP355L4C	Pik	315,0	353,0	1.485	531	2.025	2,5	7,4	0,7	2,0	2,3	95,1	95,1	94,5	0,90	10,13300	1.920	87
	Q2EP355L4D	Pik	355,0	398,0	1.485	605	2.283	2,9	8,8	0,6	1,8	2,0	95,1	95,1	94,5	0,89	10,67800	1.953	87
6kutup1000d/d																			
220/380V	Q2E90L6C	Alüminyum	0,75	1,0	940	2,6	7,7	4,0	-	2,3	-	2,5	75,9	74,7	73,2	0,68	0,00371	18	53
	Q2E90L6D	Alüminyum	1,1	1,5	940	3,2	11,3	4,0	-	2,6	-	2,6	78,1	77,6	74,8	0,65	0,00444	20	53
	Q2E100L6D	Alüminyum	1,5	2,0	940	4	15,3	4,5	-	2,4	-	2,7	79,8	79,3	76,4	0,71	0,00570	26	56
	Q2E112M6C	Alüminyum	2,2	3,0	950	5,4	22,1	5,0	-	2,3	-	2,7	81,8	81,2	78,3	0,71	0,00916	31	58
380/660V	Q2E132M6A	Alüminyum	3,0	4,0	945	7,3	29,8	1,7	5,2	1,0	3,0	3,0	83,3	82,3	79,4	0,64	0,02057	53	62
	Q2E132M6B	Alüminyum	4,0	5,5	965	10,5	39,8	1,8	5,3	0,6	1,9	2,3	84,6	83,5	80,7	0,65	0,02070	54	62
	Q2E132M6C	Alüminyum	5,5	7,5	945	13,1	54,7	1,6	4,9	0,8	2,4	2,6	86,1	85,7	83,9	0,76	0,02709	67	62
	Q2E160L6B	Alüminyum	7,5	10,0	965	18,7	74,6	2,0	6,0	1,1	3,2	3,4	87,2	84,3	81,7	0,66	0,07040	94	63
	Q2E160L6C	Alüminyum	11,0	15,0	960	25,1	109,4	1,6	4,9	0,9	2,7	2,8	88,7	88,5	86,3	0,74	0,07040	95,5	63
	Q2E180L6A	Alüminyum	15,0	20,0	960	31,8	147,7	2,0	5,9	0,6	1,8	2,6	89,7	89,5	87,3	0,80	0,18369	115	64
	Q2E200L6B	Alüminyum	18,5	25,0	970	38,0	182,2	1,8	5,5	0,5	1,6	2,4	90,4	90,2	89,6	0,83	0,27088	155	64
	Q2E200L6C	Alüminyum	22,0	30,0	970	45,6	216,6	1,8	5,5	0,5	1,6	2,4	90,9	90,7	90,1	0,83	0,31281	165	64
Q2E225M6B	Alüminyum	30,0	40,0	980	60,9	287,6	1,8	5,4	0,5	1,6	2,3	91,7	91,6	90,7	0,82	0,49334	221	65	

ELEKTRİKSEL ÖZELLİKLER - 50 Hz / ELECTRICAL CHARACTERISTICS AT 50 Hz

Motor Tipi Motor Type	Gövde Tipi Housing Type	Nominal / Rated Values					Kalkıştaki Değerler / Starting Values					Devirline Moment Oranı Brake-down Torque Ratio Mk/Mn	Verim * Efficiency*			Cos φ	J kgm ²	Ağırlık (B3) Weight (B3) kg	Ses Seviyesi dB(A)** Sound Pressure Level dB(A)**
		Güç / Power kW HP	Devir Speed d/d	Akım Current A	Moment Torque Nm	Akım Current I _A / A _N	Moment Torque M _A / M _N	η%	4/4	3/4	2/4								
2kutup3000d/d																			
220/380V	Q2E71M2DE	Alüminyum	0,75	1,0	2870	1,7	2,4	8,8	-	5,0	-	5,2	77,4	77,5	75,9	0,77	0,00110	11	56
	Q2E80M2DE	Alüminyum	1,5	2,0	2875	3,0	5,0	8,1	-	4,0	-	4,3	81,5	82,0	80,9	0,76	0,00150	13	58
	Q2E90L2DE	Alüminyum	3,0	4,0	2880	6,1	9,9	8,3	-	4,0	-	4,5	84,6	84,1	80,8	0,75	0,00182	18	62
380/660V	Q2E100L2DE	Alüminyum	4,0	5,5	2900	7,9	13,3	3,0	9,3	1,4	4,3	5,2	85,9	86,0	84,1	0,77	0,00335	27	64
	Q2E112M2CE	Alüminyum	5,5	7,5	2910	9,1	17,9	3,1	9,5	1,4	4,2	5,0	86,3	86,5	84,7	0,87	0,00489	31	67
	Q2E132M2AE	Alüminyum	11,0	15,0	2923	13,6	24,5	2,9	9,0	1,2	3,6	4,0	88,3	87,9	86,1	0,89	0,01596	53	70
	Q2E160L2DE	Alüminyum	22,0	30,0	2943	31,4	60,0	2,6	8,2	1,1	3,3	3,9	91,4	91,8	91,2	0,92	0,04075	92	71
	Q2EP250M2C	Pik	75,0	100,0	2975	125,4	241,1	2,5	7,5	0,8	2,8	3,3	93,8	93,7	92,5	0,92	0,54033	576	84
	Q2EP280M2D	Pik	110,0	150,0	2980	191,0	352,4	2,6	7,7	0,9	2,9	3,4	94,3	94,3	93,6	0,88	0,74111	640	84
4kutup1500d/d																			
220/380V	Q2E80M4DE	Alüminyum	1,1	1,5	1438	1,9	4,9	5,5	-	3,2	-	3,5	79,9	79,4	76,3	0,72	0,00268	12,5	49
	Q2E90L4DE	Alüminyum	2,2	3,0	1440	4,8	14,5	7,5	-	3,5	-	4,0	84,3	83,5	80,6	0,70	0,00365	18	54
380/660V	Q2E112M4DE	Alüminyum	5,5	7,5	1458	8,5	26,2	2,8	8,6	1,1	3,2	4,3	86,7	86,7	85,1	0,77	0,01123	34	58
	Q2EP250M4E	Pik	75,0	100,0	1485	134,2	485,7	2,6	7,8	0,8	2,9	3,4	94,0	93,9	93,2	0,86	1,06114	624	73
	Q2EP280M4D	Pik	110,0	150,0	1485	200,3	714,0	2,8	7,9	0,8	2,9	3,4	94,5	94,3	93,1	0,84	1,25586	654	73

BOYUTLAR / DIMENSIONS - B3

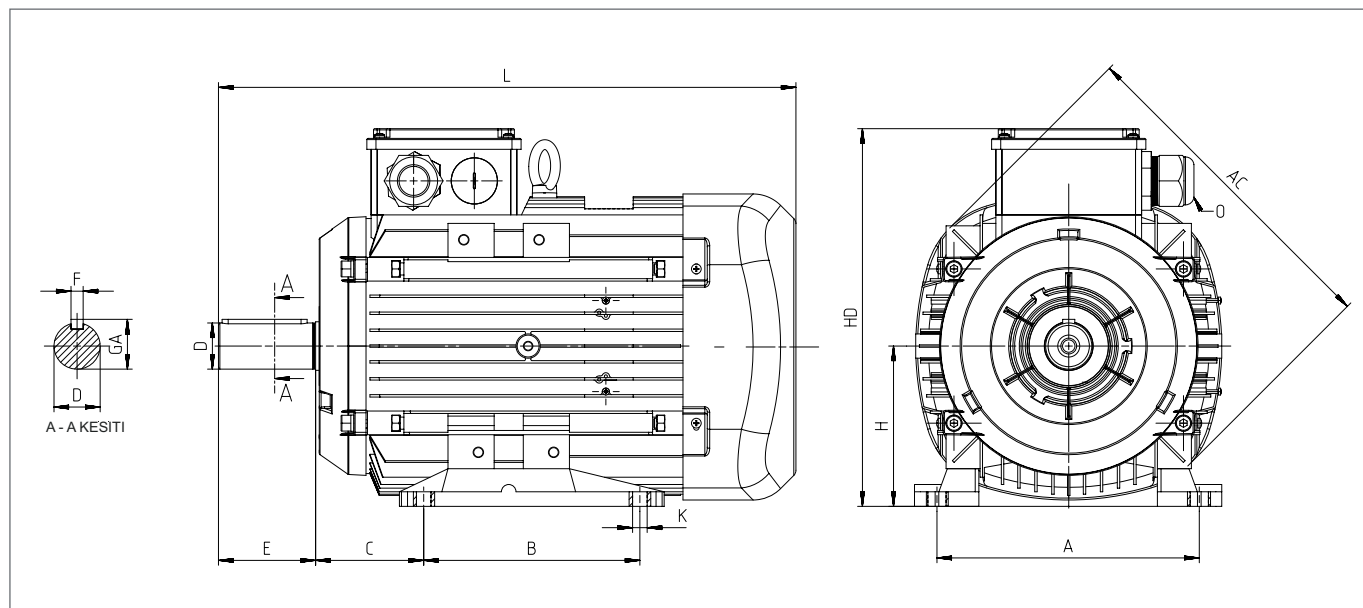

Güç Power (kW)	Kutup Sayısı Number of Poles	Motor Tipi Motor Type	Gövde Tipi Housing Type	Ana Boyutlar Main Dimensions			Ayaklı Motorlar / Foot Mounted Motors						Mil / Shaft				Rulman / Bearing		Keçe / Seal	
				AC	L	O	B	A	H	HD	K	C	D ⁽¹⁾	E	GA	F ⁽²⁾	Kasnak Tarafı Drive Side	Kasnak Tarafı Aksi Non Drive Side	Kasnak Tarafı Drive Side	Kasnak Tarafı Aksi Non Drive Side
0,25	4	Q2E71M4B	Alüminyum	138	252,5	1*M20	90	112	71	190	7	45	14	30	16	5	6202-2Z	6202-2Z	15*24*5	15*24*5
	2	Q2E71M2C	Alüminyum	138	252,5	1*M20	90	112	71	190	7	45	14	30	16	5	6202-2Z	6202-2Z	15*24*5	15*24*5
0,37	4	Q2E71M4B	Alüminyum	138	252,5	1*M20	90	112	71	190	7	45	14	30	16	5	6202-2Z	6202-2Z	15*24*5	15*24*5
	2	Q2E71M2D	Alüminyum	138	252,5	1*M20	90	112	71	190	7	45	14	30	16	5	6202-2Z	6202-2Z	15*24*5	15*24*5
0,55	4	Q2E80M4B	Alüminyum	158	283,5	1*M20	100	125	80	195	10	50	19	40	21,5	6	6204-2Z	6204-2Z	20*30*7	20*30*7
	2	Q2E71M2DE	Alüminyum	138	252,5	1*M20	90	112	71	190	7	45	14	30	16,0	5	6202-2Z	6202-2Z	15*24*5	15*24*5
0,75	2	Q2E80M2B	Alüminyum	158	283,5	1*M20	100	125	80	195	10	50	19	40	21,5	6	6204-2Z	6204-2Z	20*30*7	20*30*7
	4	Q2E80M4D	Alüminyum	158	283,5	1*M20	100	125	80	195	10	50	19	40	21,5	6	6204-2Z	6204-2Z	20*30*7	20*30*7
	6	Q2E90L6C	Alüminyum	193	316,5	1*M25	100	140	90	222	10	56	24	50	27	8	6305-2Z	6205-2Z	25*40*7	25*40*7
	2	Q2E80M2D	Alüminyum	158	283,5	1*M20	100	125	80	195	10	50	19	40	21,5	6	6204-2Z	6204-2Z	20*30*7	20*30*7
1,1	4	Q2E80M4DE	Alüminyum	158	283,5	1*M20	100	125	80	195	10	50	19	40	21,5	6	6204-2Z	6204-2Z	20*30*7	20*30*7
	4	Q2E90L4C	Alüminyum	193	316,5	1*M25	100	140	90	222	10	56	24	50	27	8	6305-2Z	6205-2Z	25*40*7	25*40*7
	6	Q2E90L6D	Alüminyum	193	344,5	1*M25	125	140	90	222	10	56	24	50	27	8	6305-2Z	6205-2Z	25*40*7	25*40*7
	2	Q2E80M2DE	Alüminyum	158	283,5	1*M20	100	125	80	195	10	50	19	40	21,5	6	6204-2Z	6204-2Z	20*30*7	20*30*7
1,5	2	Q2E90L2C	Alüminyum	193	316,5	1*M25	100	140	90	222	10	56	24	50	27	8	6305-2Z	6205-2Z	25*40*7	25*40*7
	4	Q2E90L4D	Alüminyum	193	316,5	1*M25	125	140	90	222	10	56	24	50	27	8	6305-2Z	6205-2Z	25*40*7	25*40*7
	6	Q2E100L6D	Alüminyum	217	352,0	1*M25	140	160	100	241	12	63	28	60	31	8	6306-2Z	6205-2Z	30*47*7	25*40*7
	2	Q2E90L2D	Alüminyum	193	316,5	1*M25	125	140	90	222	10	56	24	50	27	8	6305-2Z	6205-2Z	25*40*7	25*40*7
2,2	4	Q2E90L4DE	Alüminyum	193	344,5	1*M25	125	140	90	222	10	56	24	50	27	8	6305-2Z	6205-2Z	25*40*7	25*40*7
	4	Q2E100L4C	Alüminyum	217	352,0	1*M25	140	160	100	241	12	63	28	60	31	8	6306-2Z	6205-2Z	30*47*7	25*40*7
	6	Q2E112M6C	Alüminyum	232	395,5	2*M25	140	190	112	261	12	70	28	60	31	8	6306-2Z	6206-2Z	30*47*7	30*47*7
	2	Q2E90L2DE	Alüminyum	193	316,5	1*M25	125	140	90	222	10	56	24	50	27	8	6305-2Z	6205-2Z	25*40*7	25*40*7
3,0	2	Q2E100L2C	Alüminyum	217	352,0	1*M25	140	160	100	241	12	63	28	60	31	8	6306-2Z	6205-2Z	30*47*7	25*40*7
	4	Q2E100L4D	Alüminyum	217	352,0	1*M25	140	160	100	241	12	63	28	60	31	8	6306-2Z	6205-2Z	30*47*7	25*40*7
	6	Q2E132M6A	Alüminyum	279	475,5	2*M32	140	216	132	314	12	89	38	80	41	10	6208-2Z	6208-2Z	40*62*10	40*62*10

BOYUTLAR / DIMENSIONS - B3

Güç Power (kW)	Kutup Sayısı Number of Poles	Motor Tipi Motor Type	Gövde Tipi Housing Type	Ana Boyutlar Main Dimensions			Ayaklı Motorlar / Foot Mounted Motors						Mil / Shaft				Rulman / Bearing		Keçe / Seal	
				AC	L	O	B	A	H	HD	K	C	D ⁽¹⁾	E	GA	F ⁽²⁾	Kasnak Tarafı Drive Side	Kasnak Tarafı Aksi Non Drive Side	Kasnak Tarafı Drive Side	Kasnak Tarafı Aksi Non Drive Side
4,0	2	Q2E100L2DE	Alüminyum	217	352,0	1*M25	140	160	100	241	12	63	28	60	31	8	6306-2Z	6205-2Z	30*47*7	25*40*7
	2	Q2E112M2C	Alüminyum	232	395,5	2*M25	140	190	112	261	12	70	28	60	31	8	6306-2Z	6206-2Z	30*47*7	30*47*7
	4	Q2E112M4C	Alüminyum	232	395,5	2*M25	140	190	112	261	12	70	28	60	31	8	6306-2Z	6206-2Z	30*47*7	30*47*7
	6	Q2E132M6B	Alüminyum	279	475,5	2*M32	178	216	132	314	12	89	38	80	41	10	6208-2Z	6208-2Z	40*62*10	40*62*10
5,5	2	Q2E112M2CE	Alüminyum	232	395,5	2*M25	140	190	112	261	12	70	28	60	31	8	6306-2Z	6206-2Z	30*47*7	30*47*7
	4	Q2E112M4D	Alüminyum	232	395,5	2*M25	140	190	112	261	12	70	28	60	31	8	6306-2Z	6206-2Z	30*47*7	30*47*7
	2	Q2E132S2C	Alüminyum	279	440,5	2*M32	140	216	132	314	12	89	38	80	41	10	6208-2Z	6208-2Z	40*62*10	40*62*10
	4	Q2E132M4B	Alüminyum	279	475,5	2*M32	140	216	132	314	12	89	38	80	41	10	6208-2Z	6208-2Z	40*62*10	40*62*10
7,5	6	Q2E132M6C	Alüminyum	279	475,5	2*M32	178	216	132	314	12	89	38	80	41	10	6208-2Z	6208-2Z	40*62*10	40*62*10
	2	Q2E132M2A	Alüminyum	279	475,5	2*M32	140	216	132	314	12	89	38	80	41	10	6208-2Z	6208-2Z	40*62*10	40*62*10
	4	Q2E132M4C	Alüminyum	279	475,5	2*M32	178	216	132	314	12	89	38	80	41	10	6208-2Z	6208-2Z	40*62*10	40*62*10
11,0	6	Q2E160M6B	Alüminyum	302	576,0	2*M32	210	254	160	360	15	108	42	110	45	12	6309-2Z	6209-2Z	45*72*10	45*72*10
	2	Q2E132M2AE	Alüminyum	279	475,5	2*M32	140	216	132	314	12	89	38	80	41	10	6208-2Z	6208-2Z	40*62*10	40*62*10
	2	Q2E160M2B	Alüminyum	302	576,0	2*M32	210	254	160	360	15	108	42	110	45	12	6309-2Z	6209-2Z	45*72*10	45*72*10
15,0	4	Q2E160M4B	Alüminyum	302	576,0	2*M32	210	254	160	360	15	108	42	110	45	12	6309-2Z	6209-2Z	45*72*10	45*72*10
	2	Q2E160L2A	Alüminyum	302	576,0	2*M32	210	254	160	360	15	108	42	110	45	12	6309-2Z	6209-2Z	45*72*10	45*72*10
	6	Q2E180L6A	Alüminyum	370	629,0	2*M40	279	279	180	428	15	121	48	110	51,5	14	6310-2Z	6310-2Z	50*80*10	50*80*10
18,5	2	Q2E160L2C	Alüminyum	302	576,0	2*M32	254	254	160	360	15	108	42	110	45	12	6309-2Z	6209-2Z	45*72*10	45*72*10
	4	Q2E180M4B	Alüminyum	370	629,0	2*M40	241	279	180	428	15	121	48	110	51,5	14	6310-2Z	6310-2Z	50*80*10	50*80*10
	6	Q2E200L6B	Alüminyum	415	665,0	2*M50	305	318	200	461	19	133	55	110	59	16	6312-2Z	6312-2Z	60*90*10	60*90*10
22,0	2	Q2E160L2D	Alüminyum	302	576,0	2*M32	210	254	160	360	15	108	42	110	45	12	6309-2Z	6209-2Z	45*72*10	45*72*10
	2	Q2E180M2A	Alüminyum	370	629,0	2*M40	241	279	180	428	15	121	48	110	51,5	14	6310-2Z	6310-2Z	50*80*10	50*80*10
	4	Q2E180L4B	Alüminyum	370	629,0	2*M40	279	279	180	428	15	121	48	110	51,5	14	6310-2Z	6310-2Z	50*80*10	50*80*10
	6	Q2E200L6C	Alüminyum	415	665,0	2*M50	305	318	200	461	19	133	55	110	59	16	6312-2Z	6312-2Z	60*90*10	60*90*10
30,0	2	Q2E200L2B	Alüminyum	415	665,0	2*M50	305	318	200	461	19	133	55	110	59	16	6312-2Z	6312-2Z	60*90*10	60*90*10
	4	Q2E200L4D	Alüminyum	415	665,0	2*M50	305	318	200	461	19	133	55	110	59	16	6312-2Z	6312-2Z	60*90*10	60*90*10
	6	Q2E225M6B	Alüminyum	456	765,0	2*M50	311	356	225	504	19	149	60	140	64	18	6313-2Z	6313-2Z	65*100*13	65*100*13
37,0	2	Q2E200L2C	Alüminyum	415	665,0	2*M50	305	318	200	461	19	133	55	110	59	16	6312-2Z	6312-2Z	60*90*10	60*90*10
	4	Q2E225M4C	Alüminyum	456	765,0	2*M50	286	356	225	504	19	149	60	140	64	18	6313-2Z	6313-2Z	65*100*13	65*100*13
45,0	2	Q2E225M2B	Alüminyum	456	735,0	2*M50	311	356	225	504	19	149	55	110	59	16	6313-2Z	6313-2Z	65*100*13	65*100*13
	4	Q2E225M4D	Alüminyum	456	765,0	2*M50	311	356	225	504	19	149	60	140	64	18	6313-2Z	6313-2Z	65*100*13	65*100*13
55,0	2	Q2EP250M2B	Pik	527	886,0	2*M50	349	406	250	615	24	168	60	140	64	18	6316	6316	80*100*10	80*100*10
	4	Q2EP250M4D	Pik	527	886,0	2*M50	349	406	250	615	24	168	65	140	69	18	6316	6316	80*100*10	80*100*10
75,0	2	Q2EP250M2C	Pik	527	886,0	2*M50	349	406	250	615	24	168	60	140	64	18	6316	6316	80*100*10	80*100*10
	2	Q2EP280M2B	Pik	527	1025,0	2*M50	419	457	280	647	24	190	65	140	69	18	6316	6316	80*100*10	80*100*10
	4	Q2EP250M4E	Pik	527	886,0	2*M50	349	406	250	615	24	168	65	140	69	18	6316	6316	80*100*10	80*100*10
	4	Q2EP280M4B	Pik	527	1025,0	2*M50	419	457	280	647	24	190	75	140	80	20	6316	6316	80*100*10	80*100*10
90,0	2	Q2EP280M2C	Pik	527	1025,0	2*M50	419	457	280	647	24	190	65	140	69	18	6316	6316	80*100*10	80*100*10
	4	Q2EP280M4C	Pik	527	1025,0	2*M50	419	457	280	647	24	190	75	140	80	20	6316	6316	80*100*10	80*100*10
110,0	2	Q2EP280M2D	Pik	527	1025,0	2*M50	419	457	280	647	24	190	65	140	69	18	6316	6316	80*100*10	80*100*10
	4	Q2EP280M4D	Pik	527	1025,0	2*M50	419	457	280	647	24	190	75	140	80	20	6316	6316	80*100*10	80*100*10

BOYUTLAR / DIMENSIONS - B3

Güç Power (kW)	Kutup Sayısı Number of Poles	Motor Tipi Motor Type	Gövde Tipi Housing Type	Ana Boyutlar Main Dimensions			Ayaklı Motorlar / Foot Mounted Motors						Mil / Shaft				Rulman / Bearing		Keçe / Seal	
				AC	L	O	B	A	H	HD	K	C	D ⁽¹⁾	E	GA	F ⁽²⁾	Kasnak Tarafı Drive Side	Kasnak Tarafı Aksil Non Drive Side	Kasnak Tarafı Drive Side	Kasnak Tarafı Aksil Non Drive Side
110,0	2	Q2EP315S2C	Pik	630	1180,0	2*M63	406	508	315	845	28	216	65	140	69	18	6317	6317	85*105*5.5	85*105*5.5
	4	Q2EP315S4C	Pik	630	1210,0	2*M63	406	508	315	845	28	216	80	170	85	22	6319	6319	95*115*5.5	95*115*5.5
132,0	2	Q2EP315M2C	Pik	630	1290,0	2*M63	457	508	315	845	28	216	65	140	69	18	6317	6317	85*105*5.5	85*105*5.5
	4	Q2EP315M4C	Pik	630	1320,0	2*M63	457	508	315	845	28	216	80	170	85	22	6319	6319	95*115*5.5	95*115*5.5
160,0	2	Q2EP315L2C	Pik	630	1290,0	2*M63	508	508	315	845	28	216	65	140	69	18	6317	6317	85*105*5.5	85*105*5.5
	4	Q2EP315L4C	Pik	630	1320,0	2*M63	508	508	315	845	28	216	80	170	85	22	6319	6319	95*115*5.5	95*115*5.5
200,0	2	Q2EP315L2D	Pik	630	1290,0	2*M63	508	508	315	845	28	216	65	140	69	18	6317	6317	85*105*5.5	85*105*5.5
	4	Q2EP315L4D	Pik	630	1320,0	2*M63	508	508	315	845	28	216	80	170	85	22	6319	6319	95*115*5.5	95*115*5.5
250,0	2	Q2EP355M2C	Pik	710	1486,0	4*M63	560	610	355	956	28	254	75	140	80	20	6317	6317	85*105*5.5	85*105*5.5
	4	Q2EP355M4C	Pik	710	1517,0	4*M63	560	610	355	956	28	254	95	170	100	25	6322	6322	110*130*5.5	110*130*5.5
315,0	2	Q2EP355L2C	Pik	710	1486,0	4*M63	630	610	355	956	28	254	75	140	80	20	6317	6317	85*105*5.5	85*105*5.5
	4	Q2EP355L4C	Pik	710	1517,0	4*M63	630	610	355	956	28	254	95	170	100	25	6322	6322	110*130*5.5	110*130*5.5
355,0	2	Q2EP355L2D	Pik	710	1486,0	4*M63	630	610	355	956	28	254	75	140	80	20	6317	6317	85*105*5.5	85*105*5.5
	4	Q2EP355L4D	Pik	710	1517,0	4*M63	630	610	355	956	28	254	95	170	100	25	6322	6322	110*130*5.5	110*130*5.5

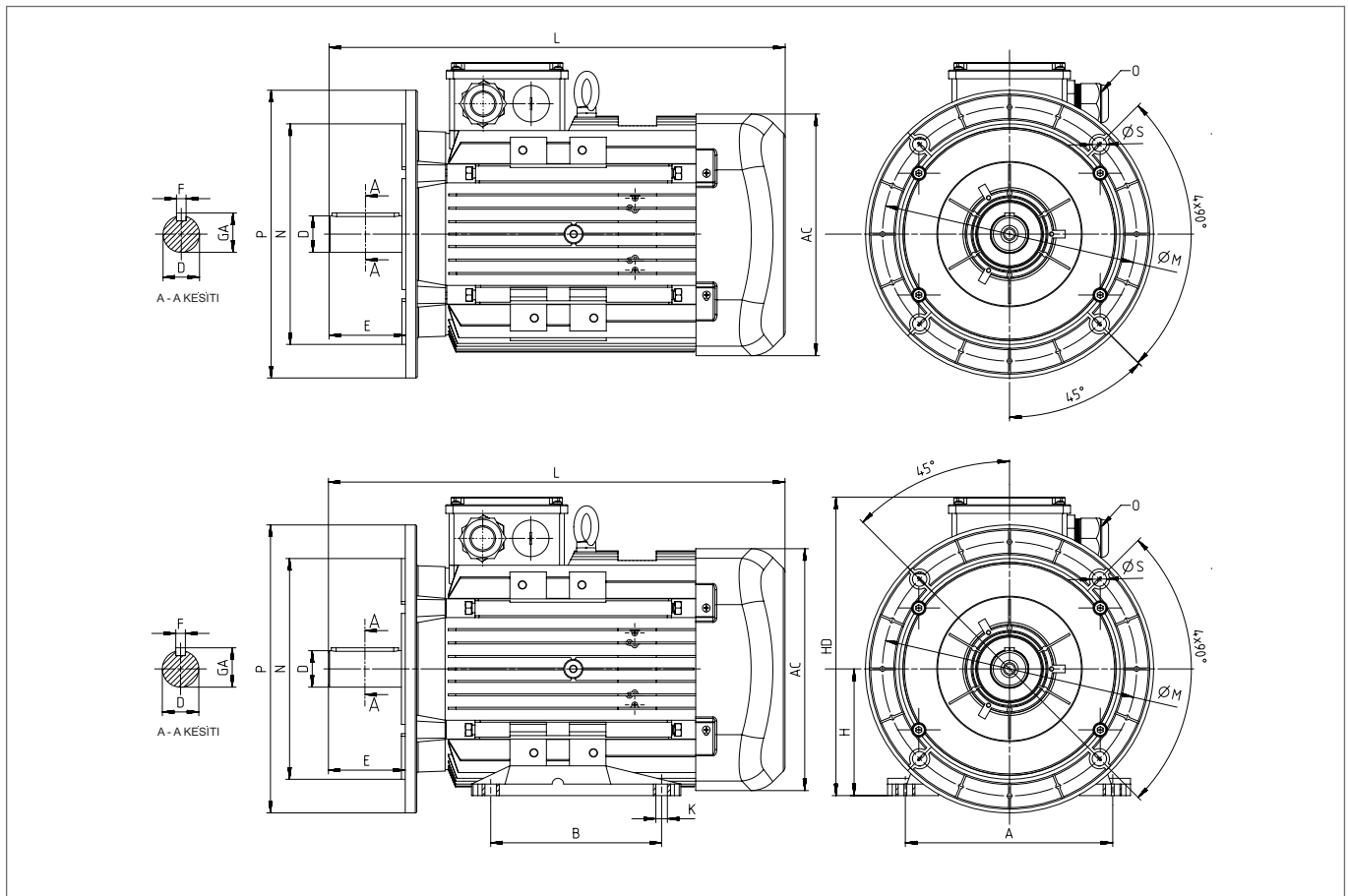
BOYUTLAR / DIMENSIONS - B5, B35

Güç Power (kW)	Kutup Sayısı Number of Poles	Motor Tipi Motor Type	Gövde Tipi Housing Type	Ana Boyutlar Main Dimensions			Ayaklı Motorlar Foot Mounted Motors							Mil / Shaft			Rulman / Bearing		Keçe / Seal		Flanş / Flange (FA) (B5)				
				AC	L	O	B	A	H	HD	K	D ⁽¹⁾	E	GA	F ⁽²⁾	Kasnak Tarafı Drive Side	Kasnak Tarafı Aksil Non Drive Side	Kasnak Tarafı Drive Side	Kasnak Tarafı Aksil Non Drive Side	P	N ⁽³⁾	M	R	S	
0,25	4	Q2E71M4B	Alüminyum	138	252,5	1*M20	90	112	71	190	7	14	30	16	5	6202-2Z	6202-2Z	15*24*5	15*24*5	160	110	130	0	10	
	2	Q2E71M2C	Alüminyum	138	252,5	1*M20	90	112	71	190	7	14	30	16	5	6202-2Z	6202-2Z	15*24*5	15*24*5	160	110	130	0	10	
0,37	4	Q2E71M4B	Alüminyum	138	252,5	1*M20	90	112	71	190	7	14	30	16	5	6202-2Z	6202-2Z	15*24*5	15*24*5	160	110	130	0	10	
	2	Q2E71M2D	Alüminyum	138	252,5	1*M20	90	112	71	190	7	14	30	16	5	6202-2Z	6202-2Z	15*24*5	15*24*5	160	110	130	0	10	
0,55	4	Q2E80M4B	Alüminyum	158	283,5	1*M20	100	125	80	195	10	19	40	21,5	6	6204-2Z	6204-2Z	20*30*7	20*30*7	200	130	165	0	12	
	2	Q2E71M2DE	Alüminyum	138	252,5	1*M20	90	112	71	190	7	14	30	16,0	5	6202-2Z	6202-2Z	15*24*5	15*24*5	160	110	130	0	10	
0,75	2	Q2E80M2B	Alüminyum	158	283,5	1*M20	100	125	80	195	10	19	40	21,5	6	6204-2Z	6204-2Z	20*30*7	20*30*7	200	130	165	0	12	
	4	Q2E80M4D	Alüminyum	158	283,5	1*M20	100	125	80	195	10	19	40	21,5	6	6204-2Z	6204-2Z	20*30*7	20*30*7	200	130	165	0	12	
	6	Q2E90L6C	Alüminyum	193	316,5	1*M25	100	140	90	222	10	24	50	27	8	6305-2Z	6205-2Z	25*40*7	25*40*7	200	130	165	0	12	
1,1	2	Q2E80M2D	Alüminyum	158	283,5	1*M20	100	125	80	195	10	19	40	21,5	6	6204-2Z	6204-2Z	20*30*7	20*30*7	200	130	165	0	12	
	4	Q2E80M4DE	Alüminyum	158	283,5	1*M20	100	125	80	195	10	19	40	21,5	6	6204-2Z	6204-2Z	20*30*7	20*30*7	200	130	165	0	12	
	4	Q2E90L4C	Alüminyum	193	316,5	1*M25	100	140	90	222	10	24	50	27	8	6305-2Z	6205-2Z	25*40*7	25*40*7	200	130	165	0	12	
1,5	6	Q2E90L6D	Alüminyum	193	344,5	1*M25	125	140	90	222	10	24	50	27	8	6305-2Z	6205-2Z	25*40*7	25*40*7	200	130	165	0	12	
	2	Q2E80M2DE	Alüminyum	158	283,5	1*M20	100	125	80	195	10	19	40	21,5	6	6204-2Z	6204-2Z	20*30*7	20*30*7	200	130	165	0	12	
	2	Q2E90L2C	Alüminyum	193	316,5	1*M25	100	140	90	222	10	24	50	27	8	6305-2Z	6205-2Z	25*40*7	25*40*7	200	130	165	0	12	
2,2	4	Q2E90L4D	Alüminyum	193	316,5	1*M25	125	140	90	222	10	24	50	27	8	6305-2Z	6205-2Z	25*40*7	25*40*7	200	130	165	0	12	
	6	Q2E100L6D	Alüminyum	217	352,0	1*M25	140	160	100	241	12	28	60	31	8	6306-2Z	6205-2Z	30*47*7	25*40*7	250	180	215	0	15	
	2	Q2E90L2D	Alüminyum	193	316,5	1*M25	125	140	90	222	10	24	50	27	8	6305-2Z	6205-2Z	25*40*7	25*40*7	200	130	165	0	12	
3,0	4	Q2E90L4DE	Alüminyum	193	344,5	1*M25	125	140	90	222	10	24	50	27	8	6305-2Z	6205-2Z	25*40*7	25*40*7	200	130	165	0	12	
	4	Q2E100L4C	Alüminyum	217	352,0	1*M25	140	160	100	241	12	28	60	31	8	6306-2Z	6205-2Z	30*47*7	25*40*7	250	180	215	0	15	
	6	Q2E112M6C	Alüminyum	232	395,5	2*M25	140	190	112	261	12	28	60	31	8	6306-2Z	6206-2Z	30*47*7	30*47*7	250	180	215	0	15	
3,0	2	Q2E90L2DE	Alüminyum	193	316,5	1*M25	125	140	90	222	10	24	50	27	8	6305-2Z	6205-2Z	25*40*7	25*40*7	200	130	165	0	12	
	2	Q2E100L2C	Alüminyum	217	352,0	1*M25	140	160	100	241	12	28	60	31	8	6306-2Z	6205-2Z	30*47*7	25*40*7	250	180	215	0	15	
	4	Q2E100L4D	Alüminyum	217	352,0	1*M25	140	160	100	241	12	28	60	31	8	6306-2Z	6205-2Z	30*47*7	25*40*7	250	180	215	0	15	
	6	Q2E132M6A	Alüminyum	279	475,5	2*M32	140	216	132	314	12	38	80	41	10	6208-2Z	6208-2Z	40*62*10	40*62*10	300	230	265	0	15	

BOYUTLAR / DIMENSIONS - B5, B35

Güç Power (kW)	Kutup Sayısı Number of Poles	Motor Tipi Motor Type	Gövde Tipi Housing Type	Ana Boyutlar Main Dimensions			Ayaklı Motorlar Foot Mounted Motors					Mil / Shaft				Rulman / Bearing		Keçe / Seal		Flanş / Flange (FA) (B5)				
				AC	L	O	B	A	H	HD	K	D ⁽¹⁾	E	GA	F ⁽²⁾	Kasnak Tarafı Drive Side	Kasnak Tarafı Aksi Non Drive Side	Kasnak Tarafı Drive Side	Kasnak Tarafı Aksi Non Drive Side	P	Ø ⁽³⁾	M	R	S
4,0	2	Q2E100L2DE	Alüminyum	217	352,0	1*M25	140	160	100	241	12	28	60	31	8	6306-2Z	6205-2Z	30*47*7	25*40*7	250	180	215	0	15
	2	Q2E112M2C	Alüminyum	232	395,5	2*M25	140	190	112	261	12	28	60	31	8	6306-2Z	6206-2Z	30*47*7	30*47*7	250	180	215	0	15
	4	Q2E112M4C	Alüminyum	232	395,5	2*M25	140	190	112	261	12	28	60	31	8	6306-2Z	6206-2Z	30*47*7	30*47*7	250	180	215	0	15
	6	Q2E132M6B	Alüminyum	279	475,5	2*M32	178	216	132	314	12	38	80	41	10	6208-2Z	6208-2Z	40*62*10	40*62*10	300	230	265	0	15
5,5	2	Q2E112M2CE	Alüminyum	232	395,5	2*M25	140	190	112	261	12	28	60	31	8	6306-2Z	6206-2Z	30*47*7	30*47*7	250	180	215	0	15
	4	Q2E112M4D	Alüminyum	232	395,5	2*M25	140	190	112	261	12	28	60	31	8	6306-2Z	6206-2Z	30*47*7	30*47*7	250	180	215	0	15
	2	Q2E132S2C	Alüminyum	279	440,5	2*M32	140	216	132	314	12	38	80	41	10	6208-2Z	6208-2Z	40*62*10	40*62*10	300	230	265	0	15
	4	Q2E132M4B	Alüminyum	279	475,5	2*M32	140	216	132	314	12	38	80	41	10	6208-2Z	6208-2Z	40*62*10	40*62*10	300	230	265	0	15
7,5	2	Q2E132M2A	Alüminyum	279	475,5	2*M32	140	216	132	314	12	38	80	41	10	6208-2Z	6208-2Z	40*62*10	40*62*10	300	230	265	0	15
	4	Q2E132M4C	Alüminyum	279	475,5	2*M32	178	216	132	314	12	38	80	41	10	6208-2Z	6208-2Z	40*62*10	40*62*10	300	230	265	0	15
	6	Q2E160M6B	Alüminyum	302	576,0	2*M32	210	254	160	360	15	42	110	45	12	6309-2Z	6209-2Z	45*72*10	45*72*10	350	250	300	0	19
	2	Q2E132M2AE	Alüminyum	279	475,5	2*M32	140	216	132	314	12	38	80	41	10	6208-2Z	6208-2Z	40*62*10	40*62*10	300	230	265	0	15
11,0	2	Q2E160M2B	Alüminyum	302	576,0	2*M32	210	254	160	360	15	42	110	45	12	6309-2Z	6209-2Z	45*72*10	45*72*10	350	250	300	0	19
	4	Q2E160M4B	Alüminyum	302	576,0	2*M32	210	254	160	360	15	42	110	45	12	6309-2Z	6209-2Z	45*72*10	45*72*10	350	250	300	0	19
	6	Q2E160L6B	Alüminyum	302	576,0	2*M32	254	254	160	360	15	42	110	45	12	6309-2Z	6209-2Z	45*72*10	45*72*10	350	250	300	0	19
	2	Q2E160L2A	Alüminyum	302	576,0	2*M32	210	254	160	360	15	42	110	45	12	6309-2Z	6209-2Z	45*72*10	45*72*10	350	250	300	0	19
15,0	4	Q2E160L4A	Alüminyum	302	576,0	2*M32	254	254	160	360	15	42	110	45	12	6309-2Z	6209-2Z	45*72*10	45*72*10	350	250	300	0	19
	6	Q2E180L6A	Alüminyum	370	629,0	2*M40	279	279	180	428	15	48	110	51,5	14	6310-2Z	6310-2Z	50*80*10	50*80*10	350	250	300	0	19
	2	Q2E160L2C	Alüminyum	302	576,0	2*M32	254	254	160	360	15	42	110	45	12	6309-2Z	6209-2Z	45*72*10	45*72*10	350	250	300	0	19
	4	Q2E180M4B	Alüminyum	370	629,0	2*M40	241	279	180	428	15	48	110	51,5	14	6310-2Z	6310-2Z	50*80*10	50*80*10	350	250	300	0	19
18,5	6	Q2E200L6B	Alüminyum	415	665,0	2*M50	305	318	200	461	19	55	110	59	16	6312-2Z	6312-2Z	60*90*10	60*90*10	400	300	350	0	19
	2	Q2E160L2D	Alüminyum	302	576,0	2*M32	210	254	160	360	15	42	110	45	12	6309-2Z	6209-2Z	45*72*10	45*72*10	350	250	300	0	19
	2	Q2E180M2A	Alüminyum	370	629,0	2*M40	241	279	180	428	15	48	110	51,5	14	6310-2Z	6310-2Z	50*80*10	50*80*10	350	250	300	0	19
	4	Q2E180L4B	Alüminyum	370	629,0	2*M40	279	279	180	428	15	48	110	51,5	14	6310-2Z	6310-2Z	50*80*10	50*80*10	350	250	300	0	19
22,0	6	Q2E200L6C	Alüminyum	415	665,0	2*M50	305	318	200	461	19	55	110	59	16	6312-2Z	6312-2Z	60*90*10	60*90*10	400	300	350	0	19
	2	Q2E200L2B	Alüminyum	415	665,0	2*M50	305	318	200	461	19	55	110	59	16	6312-2Z	6312-2Z	60*90*10	60*90*10	400	300	350	0	19
	4	Q2E200L4D	Alüminyum	415	665,0	2*M50	305	318	200	461	19	55	110	59	16	6312-2Z	6312-2Z	60*90*10	60*90*10	400	300	350	0	19
	6	Q2E225M6B	Alüminyum	456	765,0	2*M50	311	356	225	504	19	60	140	64	18	6313-2Z	6313-2Z	65*100*13	65*100*13	450	350	400	0	19
30,0	2	Q2E200L2C	Alüminyum	415	665,0	2*M50	305	318	200	461	19	55	110	59	16	6312-2Z	6312-2Z	60*90*10	60*90*10	400	300	350	0	19
	4	Q2E225M4C	Alüminyum	456	765,0	2*M50	286	356	225	504	19	60	140	64	18	6313-2Z	6313-2Z	65*100*13	65*100*13	450	350	400	0	19
	2	Q2E225M2B	Alüminyum	456	735,0	2*M50	311	356	225	504	19	55	110	59	16	6313-2Z	6313-2Z	65*100*13	65*100*13	450	350	400	0	19
	4	Q2E225M4D	Alüminyum	456	765,0	2*M50	311	356	225	504	19	60	140	64	18	6313-2Z	6313-2Z	65*100*13	65*100*13	450	350	400	0	19
55,0	2	Q2EP250M2B	Pik	527	886,0	2*M50	349	406	250	615	24	60	140	64	18	6316	6316	80*100*10	80*100*10	550	450	500	0	19
	4	Q2EP250M4D	Pik	527	886,0	2*M50	349	406	250	615	24	65	140	69	18	6316	6316	80*100*10	80*100*10	550	450	500	0	19
	2	Q2EP250M2C	Pik	527	886,0	2*M50	349	406	250	615	24	60	140	64	18	6316	6316	80*100*10	80*100*10	550	450	500	0	19
	2	Q2EP280M2B	Pik	527	1025,0	2*M50	419	457	280	647	24	65	140	69	18	6316	6316	80*100*10	80*100*10	550	450	500	0	19
75,0	4	Q2EP250M4E	Pik	527	886,0	2*M50	349	406	250	615	24	65	140	69	18	6316	6316	80*100*10	80*100*10	550	450	500	0	19
	4	Q2EP280M4B	Pik	527	1025,0	2*M50	419	457	280	647	24	75	140	80	20	6316	6316	80*100*10	80*100*10	550	450	500	0	19
	2	Q2EP280M2C	Pik	527	1025,0	2*M50	419	457	280	647	24	65	140	69	18	6316	6316	80*100*10	80*100*10	550	450	500	0	19
	4	Q2EP280M4C	Pik	527	1025,0	2*M50	419	457	280	647	24	75	140	80	20	6316	6316	80*100*10	80*100*10	550	450	500	0	19
90,0	2	Q2EP280M2D	Pik	527	1025,0	2*M50	419	457	280	647	24	65	140	69	18	6316	6316	80*100*10	80*100*10	550	450	500	0	19
	4	Q2EP280M4D	Pik	527	1025,0	2*M50	419	457	280	647	24	75	140	80	20	6316	6316	80*100*10	80*100*10	550	450	500	0	19

BOYUTLAR / DIMENSIONS - B5, B35

Güç Power (kW)	Kutup Sayısı Number of Poles	Motor Tipi Motor Type	Gövde Tipi Housing Type	Ana Boyutlar Main Dimensions			Ayaklı Motorlar / Foot Mounted Motors						Mil / Shaft				Rulman / Bearing		Keçe / Seal		Flanş / Flange (FA) (B5)				
				AC	L	O	B	A	H	HD	K	C	D ⁽¹⁾	E	GA	F ⁽²⁾	Kasnak Tarafı Drive Side	Kasnak Tarafı Aksi Non Drive Side	Kasnak Tarafı Drive Side	Kasnak Tarafı Aksi Non Drive Side	P	Ø ⁽³⁾	M	R	S
110,0	2	Q2EP315S2C	Pik	630	1180,0	2*M63	406	508	315	845	28	216	65	140	69	18	6317	6317	85*105*5,5	85*105*5,5	660	550	600	0	24
	4	Q2EP315S4C	Pik	630	1210,0	2*M63	406	508	315	845	28	216	80	170	85	22	6319	6319	95*115*5,5	95*115*5,5	660	550	600	0	24
132,0	2	Q2EP315M2C	Pik	630	1290,0	2*M63	457	508	315	845	28	216	65	140	69	18	6317	6317	85*105*5,5	85*105*5,5	660	550	600	0	24
	4	Q2EP315M4C	Pik	630	1320,0	2*M63	457	508	315	845	28	216	80	170	85	22	6319	6319	95*115*5,5	95*115*5,5	660	550	600	0	24
160,0	2	Q2EP315L2C	Pik	630	1290,0	2*M63	508	508	315	845	28	216	65	140	69	18	6317	6317	85*105*5,5	85*105*5,5	660	550	600	0	24
	4	Q2EP315L4C	Pik	630	1320,0	2*M63	508	508	315	845	28	216	80	170	85	22	6319	6319	95*115*5,5	95*115*5,5	660	550	600	0	24
200,0	2	Q2EP315L2D	Pik	630	1290,0	2*M63	508	508	315	845	28	216	65	140	69	18	6317	6317	85*105*5,5	85*105*5,5	660	550	600	0	24
	4	Q2EP315L4D	Pik	630	1320,0	2*M63	508	508	315	845	28	216	80	170	85	22	6319	6319	95*115*5,5	95*115*5,5	660	550	600	0	24
250,0	2	Q2EP355M2C	Pik	710	1486,0	4*M63	560	610	355	956	28	254	75	140	80	20	6317	6317	85*105*5,5	85*105*5,5	800	680	740	0	24
	4	Q2EP355M4C	Pik	710	1517,0	4*M63	560	610	355	956	28	254	95	170	100	25	6322	6322	110*130*5,5	110*130*5,5	800	680	740	0	24
315,0	2	Q2EP355L2C	Pik	710	1486,0	4*M63	630	610	355	956	28	254	75	140	80	20	6317	6317	85*105*5,5	85*105*5,5	800	680	740	0	24
	4	Q2EP355L4C	Pik	710	1517,0	4*M63	630	610	355	956	28	254	95	170	100	25	6322	6322	110*130*5,5	110*130*5,5	800	680	740	0	24
355,0	2	Q2EP355L2D	Pik	710	1486,0	4*M63	630	610	355	956	28	254	75	140	80	20	6317	6317	85*105*5,5	85*105*5,5	800	680	740	0	24
	4	Q2EP355L4D	Pik	710	1517,0	4*M63	630	610	355	956	28	254	95	170	100	25	6322	6322	110*130*5,5	110*130*5,5	800	680	740	0	24

BOYUTLAR / DIMENSIONS - B14a, B34a

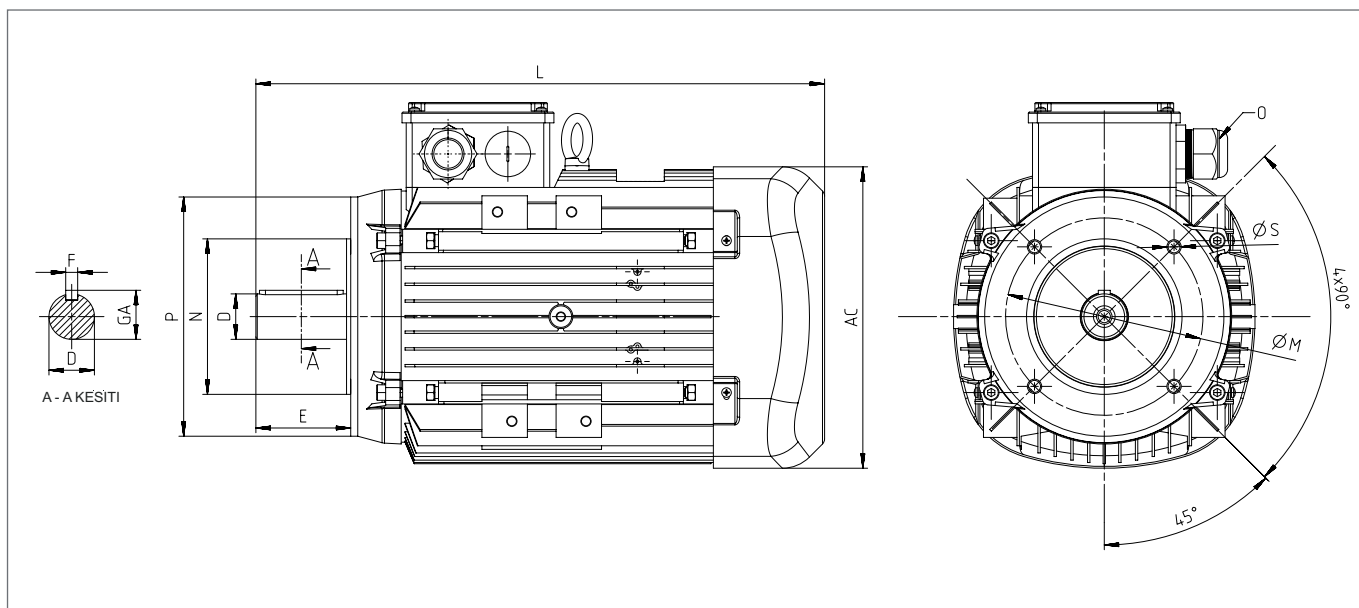

Güç Power (kW)	Kutup Sayısı Number of Poles	Motor Tipi Motor Type	Gövde Tipi Housing Type	Ana Boyutlar Main Dimensions			Ayaklı Motorlar Foot Mounted Motors						Mil / Shaft				Rulman / Bearing				Keçe / Seal					Flanş / Flange (FC) (B14a)				
				AC	L	O	B	A	H	HD	K	D ⁽¹⁾	E	GA	F ⁽²⁾	Kasnak Tarafı Drive Side	Kasnak Tarafı Non Drive Side	Kasnak Tarafı Drive Side	Kasnak Tarafı Non Drive Side	P	N ⁽³⁾	M	R	S						
0,25	4	Q2E71M4B	Alüminyum	138	252,5	1*M20	90	112	71	190	7	14	30	16	5	6202-2Z	6202-2Z	15*24*5	15*24*5	105	70	85	0	M6						
	2	Q2E71M2C	Alüminyum	138	252,5	1*M20	90	112	71	190	7	14	30	16	5	6202-2Z	6202-2Z	15*24*5	15*24*5	105	70	85	0	M6						
0,37	4	Q2E71M4B	Alüminyum	138	252,5	1*M20	90	112	71	190	7	14	30	16	5	6202-2Z	6202-2Z	15*24*5	15*24*5	105	70	85	0	M6						
	2	Q2E71M2D	Alüminyum	138	252,5	1*M20	90	112	71	190	7	14	30	16	5	6202-2Z	6202-2Z	15*24*5	15*24*5	105	70	85	0	M6						
0,55	4	Q2E80M4B	Alüminyum	158	283,5	1*M20	100	125	80	195	10	19	40	21,5	6	6204-2Z	6204-2Z	20*30*7	20*30*7	120	80	100	0	M6						
	2	Q2E71M2DE	Alüminyum	138	252,5	1*M20	90	112	71	190	7	14	30	16,0	5	6202-2Z	6202-2Z	15*24*5	15*24*5	105	70	85	0	M6						
0,75	2	Q2E80M2B	Alüminyum	158	283,5	1*M20	100	125	80	195	10	19	40	21,5	6	6204-2Z	6204-2Z	20*30*7	20*30*7	120	80	100	0	M6						
	4	Q2E80M4D	Alüminyum	158	283,5	1*M20	100	125	80	195	10	19	40	21,5	6	6204-2Z	6204-2Z	20*30*7	20*30*7	120	80	100	0	M6						
	6	Q2E90L6C	Alüminyum	193	316,5	1*M25	100	140	90	222	10	24	50	27	8	6305-2Z	6205-2Z	25*40*7	25*40*7	140	95	115	0	M8						
1,1	2	Q2E80M2D	Alüminyum	158	283,5	1*M20	100	125	80	195	10	19	40	21,5	6	6204-2Z	6204-2Z	20*30*7	20*30*7	120	80	100	0	M6						
	4	Q2E80M4DE	Alüminyum	158	283,5	1*M20	100	125	80	195	10	19	40	21,5	6	6204-2Z	6204-2Z	20*30*7	20*30*7	120	80	100	0	M6						
	4	Q2E90L4C	Alüminyum	193	316,5	1*M25	100	140	90	222	10	24	50	27	8	6305-2Z	6205-2Z	25*40*7	25*40*7	140	95	115	0	M8						
1,5	6	Q2E90L6D	Alüminyum	193	344,5	1*M25	125	140	90	222	10	24	50	27	8	6305-2Z	6205-2Z	25*40*7	25*40*7	140	95	115	0	M8						
	2	Q2E80M2DE	Alüminyum	158	283,5	1*M20	100	125	80	195	10	19	40	21,5	6	6204-2Z	6204-2Z	20*30*7	20*30*7	120	80	100	0	M6						
	2	Q2E90L2C	Alüminyum	193	316,5	1*M25	100	140	90	222	10	24	50	27	8	6305-2Z	6205-2Z	25*40*7	25*40*7	140	95	115	0	M8						
	4	Q2E90L4D	Alüminyum	193	316,5	1*M25	125	140	90	222	10	24	50	27	8	6305-2Z	6205-2Z	25*40*7	25*40*7	140	95	115	0	M8						
2,2	6	Q2E100L6D	Alüminyum	217	352,0	1*M25	140	160	100	241	12	28	60	31	8	6306-2Z	6205-2Z	30*47*7	25*40*7	160	110	130	0	M8						
	2	Q2E90L2D	Alüminyum	193	316,5	1*M25	125	140	90	222	10	24	50	27	8	6305-2Z	6205-2Z	25*40*7	25*40*7	140	95	115	0	M8						
	4	Q2E90L4DE	Alüminyum	193	344,5	1*M25	125	140	90	222	10	24	50	27	8	6305-2Z	6205-2Z	25*40*7	25*40*7	140	95	115	0	M8						
	4	Q2E100L4C	Alüminyum	217	352,0	1*M25	140	160	100	241	12	28	60	31	8	6306-2Z	6205-2Z	30*47*7	25*40*7	160	110	130	0	M8						
3,0	6	Q2E112M6C	Alüminyum	232	395,5	2*M25	140	190	112	261	12	28	60	31	8	6306-2Z	6206-2Z	30*47*7	30*47*7	160	110	130	0	M8						
	2	Q2E90L2DE	Alüminyum	193	316,5	1*M25	125	140	90	222	10	24	50	27	8	6305-2Z	6205-2Z	25*40*7	25*40*7	140	95	115	0	M8						
	2	Q2E100L2C	Alüminyum	217	352,0	1*M25	140	160	100	241	12	28	60	31	8	6306-2Z	6205-2Z	30*47*7	25*40*7	160	110	130	0	M8						
	4	Q2E100L4D	Alüminyum	217	352,0	1*M25	140	160	100	241	12	28	60	31	8	6306-2Z	6205-2Z	30*47*7	25*40*7	160	110	130	0	M8						
4,0	6	Q2E132M6A	Alüminyum	279	475,5	2*M32	140	216	132	314	12	38	80	41	10	6208-2Z	6208-2Z	40*62*10	40*62*10	200	130	165	0	M10						
	2	Q2E100L2DE	Alüminyum	217	352,0	1*M25	140	160	100	241	12	28	60	31	8	6306-2Z	6205-2Z	30*47*7	25*40*7	160	110	130	0	M8						
	2	Q2E112M2C	Alüminyum	232	395,5	2*M25	140	190	112	261	12	28	60	31	8	6306-2Z	6206-2Z	30*47*7	30*47*7	160	110	130	0	M8						
	4	Q2E112M4C	Alüminyum	232	395,5	2*M25	140	190	112	261	12	28	60	31	8	6306-2Z	6206-2Z	30*47*7	30*47*7	160	110	130	0	M8						
4,0	6	Q2E132M6B	Alüminyum	279	475,5	2*M32	178	216	132	314	12	38	80	41	10	6208-2Z	6208-2Z	40*62*10	40*62*10	200	130	165	0	M10						

BOYUTLAR / DIMENSIONS - B14a, B34a

Güç Power (kW)	Kutup Sayısı Number of Poles	Motor Tipi Motor Type	Gövde Tipi Housing Type	Ana Boyutlar Main Dimensions			Ayaklı Motorlar Foot Mounted Motors					Mil / Shaft				Rulman / Bearing		Keçe / Seal		Flanş / Flange (FC) (B14a)				
				AC	L	O	B	A	H	HD	K	D ⁽¹⁾	E	GA	F ⁽²⁾	Kasnak Tarafı Drive Side	Kasnak Tarafı Non Drive Side	Kasnak Tarafı Drive Side	Kasnak Tarafı Non Drive Side	P	N ⁽³⁾	M	R	S
5,5	2	Q2E112M2CE	Alüminyum	232	395,5	2*M25	140	190	112	261	12	28	60	31	8	6306-2Z	6206-2Z	30*47*7	30*47*7	160	110	130	0	M8
	4	Q2E112M4D	Alüminyum	232	395,5	2*M25	140	190	112	261	12	28	60	31	8	6306-2Z	6206-2Z	30*47*7	30*47*7	160	110	130	0	M8
	2	Q2E132S2C	Alüminyum	279	440,5	2*M32	140	216	132	314	12	38	80	41	10	6208-2Z	6208-2Z	40*62*10	40*62*10	200	130	165	0	M10
	4	Q2E132M4B	Alüminyum	279	475,5	2*M32	140	216	132	314	12	38	80	41	10	6208-2Z	6208-2Z	40*62*10	40*62*10	200	130	165	0	M10
7,5	6	Q2E132M6C	Alüminyum	279	475,5	2*M32	178	216	132	314	12	38	80	41	10	6208-2Z	6208-2Z	40*62*10	40*62*10	200	130	165	0	M10
	2	Q2E132M2A	Alüminyum	279	475,5	2*M32	140	216	132	314	12	38	80	41	10	6208-2Z	6208-2Z	40*62*10	40*62*10	200	130	165	0	M10
11,0	4	Q2E132M4C	Alüminyum	279	475,5	2*M32	178	216	132	314	12	38	80	41	10	6208-2Z	6208-2Z	40*62*10	40*62*10	200	130	165	0	M10
	2	Q2E132M2AE	Alüminyum	279	475,5	2*M32	140	216	132	314	12	38	80	41	10	6208-2Z	6208-2Z	40*62*10	40*62*10	200	130	165	0	M10

(1) Toleranslar 28 mm'ye kadar DIN EN 50347 "j6", 28 mm ve üzeri "k6"

(2) DIN 6885'e göre

(3) Tolerans DIN EN 50347 "j6"

(1) Tolerance DIN 50347 "j6" up to 28 mm "k6" above 28 mm

(2) According to DIN 6885

(3) Tolerance DIN EN 50347 "j6"

BOYUTLAR / DIMENSIONS - B14b, B34b

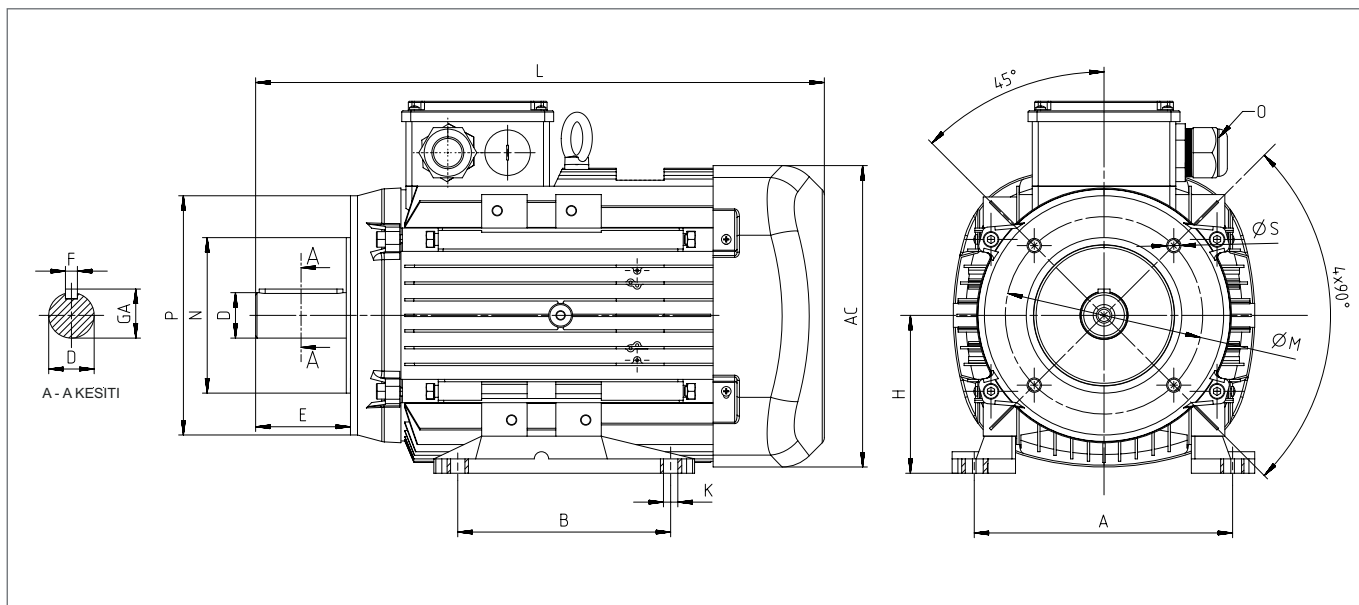

Güç Power (kW)	Kutup Sayısı Number of Poles	Motor Tipi Motor Type	Gövde Tipi Housing Type	Ana Boyutlar Main Dimensions			Ayaklı Motorlar Foot Mounted Motors						Mil / Shaft				Rulman / Bearing				Keçe / Seal					Flanş / Flange (FB) (B14b)				
				AC	L	O	B	A	H	HD	K	D ⁽¹⁾	E	GA	F ⁽²⁾	Kasnak Tarafı Drive Side	Kasnak Tarafı Non Drive Side	Kasnak Tarafı Drive Side	Kasnak Tarafı Non Drive Side	P	N ⁽³⁾	M	R	S						
0,25	4	Q2E71M4B	Alüminyum	138	252,5	1*M20	90	112	71	190	7	14	30	16	5	6202-2Z	6202-2Z	15*24*5	15*24*5	140	95	115	0	M8						
	2	Q2E71M2C	Alüminyum	138	252,5	1*M20	90	112	71	190	7	14	30	16	5	6202-2Z	6202-2Z	15*24*5	15*24*5	140	95	115	0	M8						
0,37	4	Q2E71M4B	Alüminyum	138	252,5	1*M20	90	112	71	190	7	14	30	16	5	6202-2Z	6202-2Z	15*24*5	15*24*5	140	95	115	0	M8						
	2	Q2E71M2D	Alüminyum	138	252,5	1*M20	90	112	71	190	7	14	30	16	5	6202-2Z	6202-2Z	15*24*5	15*24*5	140	95	115	0	M8						
0,55	4	Q2E80M4B	Alüminyum	158	283,5	1*M20	100	125	80	195	10	19	40	21,5	6	6204-2Z	6204-2Z	20*30*7	20*30*7	160	110	130	0	M8						
	2	Q2E71M2DE	Alüminyum	138	252,5	1*M20	90	112	71	190	7	14	30	16,0	5	6202-2Z	6202-2Z	15*24*5	15*24*5	140	95	115	0	M8						
0,75	2	Q2E80M2B	Alüminyum	158	283,5	1*M20	100	125	80	195	10	19	40	21,5	6	6204-2Z	6204-2Z	20*30*7	20*30*7	160	110	130	0	M8						
	4	Q2E80M4D	Alüminyum	158	283,5	1*M20	100	125	80	195	10	19	40	21,5	6	6204-2Z	6204-2Z	20*30*7	20*30*7	160	110	130	0	M8						
	6	Q2E90L6C	Alüminyum	193	316,5	1*M25	100	140	90	222	10	24	50	27	8	6305-2Z	6205-2Z	25*40*7	25*40*7	160	110	130	0	M8						
1,1	2	Q2E80M2D	Alüminyum	158	283,5	1*M20	100	125	80	195	10	19	40	21,5	6	6204-2Z	6204-2Z	20*30*7	20*30*7	160	110	130	0	M8						
	4	Q2E80M4DE	Alüminyum	158	283,5	1*M20	100	125	80	195	10	19	40	21,5	6	6204-2Z	6204-2Z	20*30*7	20*30*7	160	110	130	0	M8						
	4	Q2E90L4C	Alüminyum	193	316,5	1*M25	100	140	90	222	10	24	50	27	8	6305-2Z	6205-2Z	25*40*7	25*40*7	160	110	130	0	M8						
1,5	6	Q2E90L6D	Alüminyum	193	344,5	1*M25	125	140	90	222	10	24	50	27	8	6305-2Z	6205-2Z	25*40*7	25*40*7	160	110	130	0	M8						
	2	Q2E80M2DE	Alüminyum	158	283,5	1*M20	100	125	80	195	10	19	40	21,5	6	6204-2Z	6204-2Z	20*30*7	20*30*7	160	110	130	0	M8						
	2	Q2E90L2C	Alüminyum	193	316,5	1*M25	100	140	90	222	10	24	50	27	8	6305-2Z	6205-2Z	25*40*7	25*40*7	160	110	130	0	M8						
	4	Q2E90L4D	Alüminyum	193	316,5	1*M25	125	140	90	222	10	24	50	27	8	6305-2Z	6205-2Z	25*40*7	25*40*7	160	110	130	0	M8						
2,2	6	Q2E100L6D	Alüminyum	217	352,0	1*M25	140	160	100	241	12	28	60	31	8	6306-2Z	6205-2Z	30*47*7	25*40*7	200	130	165	0	M10						
	2	Q2E90L2D	Alüminyum	193	316,5	1*M25	125	140	90	222	10	24	50	27	8	6305-2Z	6205-2Z	25*40*7	25*40*7	160	110	130	0	M8						
	4	Q2E90L4DE	Alüminyum	193	344,5	1*M25	125	140	90	222	10	24	50	27	8	6305-2Z	6205-2Z	25*40*7	25*40*7	160	110	130	0	M8						
	4	Q2E100L4C	Alüminyum	217	352,0	1*M25	140	160	100	241	12	28	60	31	8	6306-2Z	6205-2Z	30*47*7	25*40*7	200	130	165	0	M10						
	6	Q2E112M6C	Alüminyum	232	395,5	2*M25	140	190	112	261	12	28	60	31	8	6306-2Z	6206-2Z	30*47*7	30*47*7	200	130	165	0	M10						
3,0	2	Q2E90L2DE	Alüminyum	193	316,5	1*M25	125	140	90	222	10	24	50	27	8	6305-2Z	6205-2Z	25*40*7	25*40*7	160	110	130	0	M8						
	2	Q2E100L2C	Alüminyum	217	352,0	1*M25	140	160	100	241	12	28	60	31	8	6306-2Z	6205-2Z	30*47*7	25*40*7	200	130	165	0	M10						
	4	Q2E100L4D	Alüminyum	217	352,0	1*M25	140	160	100	241	12	28	60	31	8	6306-2Z	6205-2Z	30*47*7	25*40*7	200	130	165	0	M10						
	6	Q2E132M6A	Alüminyum	279	475,5	2*M32	140	216	132	314	12	38	80	41	10	6208-2Z	6208-2Z	40*62*10	40*62*10	250	180	215	0	M12 veya 15						
4,0	2	Q2E100L2DE	Alüminyum	217	352,0	1*M25	140	160	100	241	12	28	60	31	8	6306-2Z	6205-2Z	30*47*7	25*40*7	200	130	165	0	M10						
	2	Q2E112M2C	Alüminyum	232	395,5	2*M25	140	190	112	261	12	28	60	31	8	6306-2Z	6206-2Z	30*47*7	30*47*7	200	130	165	0	M10						
	4	Q2E112M4C	Alüminyum	232	395,5	2*M25	140	190	112	261	12	28	60	31	8	6306-2Z	6206-2Z	30*47*7	30*47*7	200	130	165	0	M10						
	6	Q2E132M6B	Alüminyum	279	475,5	2*M32	178	216	132	314	12	38	80	41	10	6208-2Z	6208-2Z	40*62*10	40*62*10	250	180	215	0	M12 veya 15						

BOYUTLAR / DIMENSIONS - B14b, B34b

Güç Power (kW)	Kutup Sayısı Number of Poles	Motor Tipi Motor Type	Gövde Tipi Housing Type	Ana Boyutlar Main Dimensions			Ayaklı Motorlar Foot Mounted Motors					Mil / Shaft				Rulman / Bearing		Keçe / Seal		Flanş / Flange (FB) (B14b)				
				AC	L	O	B	A	H	HD	K	D ⁽¹⁾	E	GA	F ⁽²⁾	Kasnak Tarafı Drive Side	Kasnak Tarafı Non Drive Side	Kasnak Tarafı Drive Side	Kasnak Tarafı Non Drive Side	P	N ⁽³⁾	M	R	S
5,5	2	Q2E112M2CE	Alüminyum	232	395,5	2*M25	140	190	112	261	12	28	60	31	8	6306-2Z	6206-2Z	30*47*7	30*47*7	200	130	165	0	M10
	4	Q2E112M4D	Alüminyum	232	395,5	2*M25	140	190	112	261	12	28	60	31	8	6306-2Z	6206-2Z	30*47*7	30*47*7	200	130	165	0	M10
	2	Q2E132S2C	Alüminyum	279	440,5	2*M32	140	216	132	314	12	38	80	41	10	6208-2Z	6208-2Z	40*62*10	40*62*10	250	180	215	0	M12 veya 15
	4	Q2E132M4B	Alüminyum	279	475,5	2*M32	140	216	132	314	12	38	80	41	10	6208-2Z	6208-2Z	40*62*10	40*62*10	250	180	215	0	M12 veya 15
	6	Q2E132M6C	Alüminyum	279	475,5	2*M32	178	216	132	314	12	38	80	41	10	6208-2Z	6208-2Z	40*62*10	40*62*10	250	180	215	0	M12 veya 15
7,5	2	Q2E132M2A	Alüminyum	279	475,5	2*M32	140	216	132	314	12	38	80	41	10	6208-2Z	6208-2Z	40*62*10	40*62*10	250	180	215	0	M12 veya 15
	4	Q2E132M4C	Alüminyum	279	475,5	2*M32	178	216	132	314	12	38	80	41	10	6208-2Z	6208-2Z	40*62*10	40*62*10	250	180	215	0	M12 veya 15
11,0	2	Q2E132M2AE	Alüminyum	279	475,5	2*M32	140	216	132	314	12	38	80	41	10	6208-2Z	6208-2Z	40*62*10	40*62*10	250	180	215	0	M12 veya 15

(1) Toleranslar 28 mm'ye kadar DIN EN 50347 "j6", 28 mm ve üzeri "k6"

(2) DIN 6885'e göre

(3) Tolerans DIN EN 50347 "j6"

(1) Tolerance DIN EN 50347 "j6" up to 28 mm "k6" above 28 mm

(2) According to DIN 6885

(3) Tolerance DIN EN 50347 "j6"

MOTOR PARÇA LİSTESİ / MOTOR PART LIST

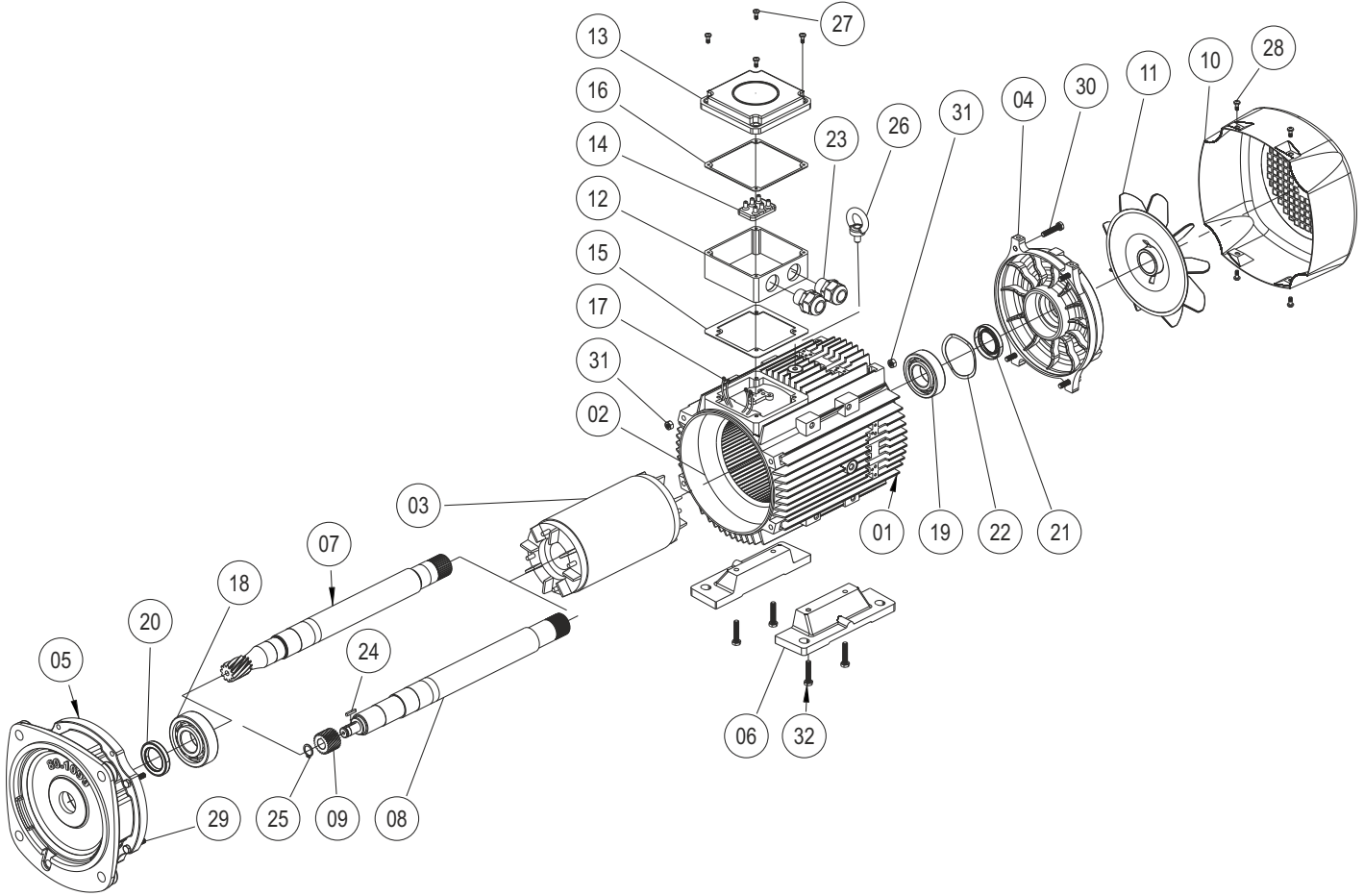

01	Gövde	01	Housing	17	Kablo Grubu	17	Lead Cables
02	Sargılı Stator	02	Wound Stator	18	Ön Rulman	18	Bal Bearing (Drive-Side)
03	Rotor	03	Rotor	19	Arka Rulman	19	Bal Bearing (Non-Drive-Side)
04	Motor Arka Kapağı	04	Nondrive - Endshield	20	Keçe (Ön)	20	Seal Ring (Front)
05	PGR Motor Bağlantı Flanşı	05	Moter Connection Flange	21	Keçe (Arka)	21	Seal Ring (Back)
06	Ayak	06	Foot	22	Rulman Gergi Yayı	22	Bearing Shim
07	Motor Mili (Yekpare)	07	Drive Shaft (Gearcut)	23	Rakor	23	Conduit
08	Motor Mili (Çakma)	08	Drive Shaft (Plain)	24	Kama	24	Key
09	Z1 Dişlisi	09	Z1 Gear	25	Segman	25	Circilip DIN 471
10	Fan Kapağı	10	Fan Cover	26	Mapa	26	Eye Bolt
11	Fan	11	Fan	27	Yıldız Başlı Civata	27	Pan Head Secrews
12	Terminal Kutusu	12	Terminal Box	28	Yıldız Başlı Civata	28	Pan Head Secrews
13	Terminal Kutu Kapağı	13	Terminal Box Cover	29	Civata DIN 933	29	Bolt
14	Klemens Plakası	14	Terminal Plate	30	Civata DIN 933	30	Bolt
15	Terminal Contası Alt	15	Terminal Gasket Down	31	Somun	31	Nut
16	Terminal Contası Üst	16	Terminal Gasket Up	32	Civata DIN 933	32	Bolt

FRENLİ MOTOR PARÇA LİSTESİ / BRAKE MOTOR PART LIST

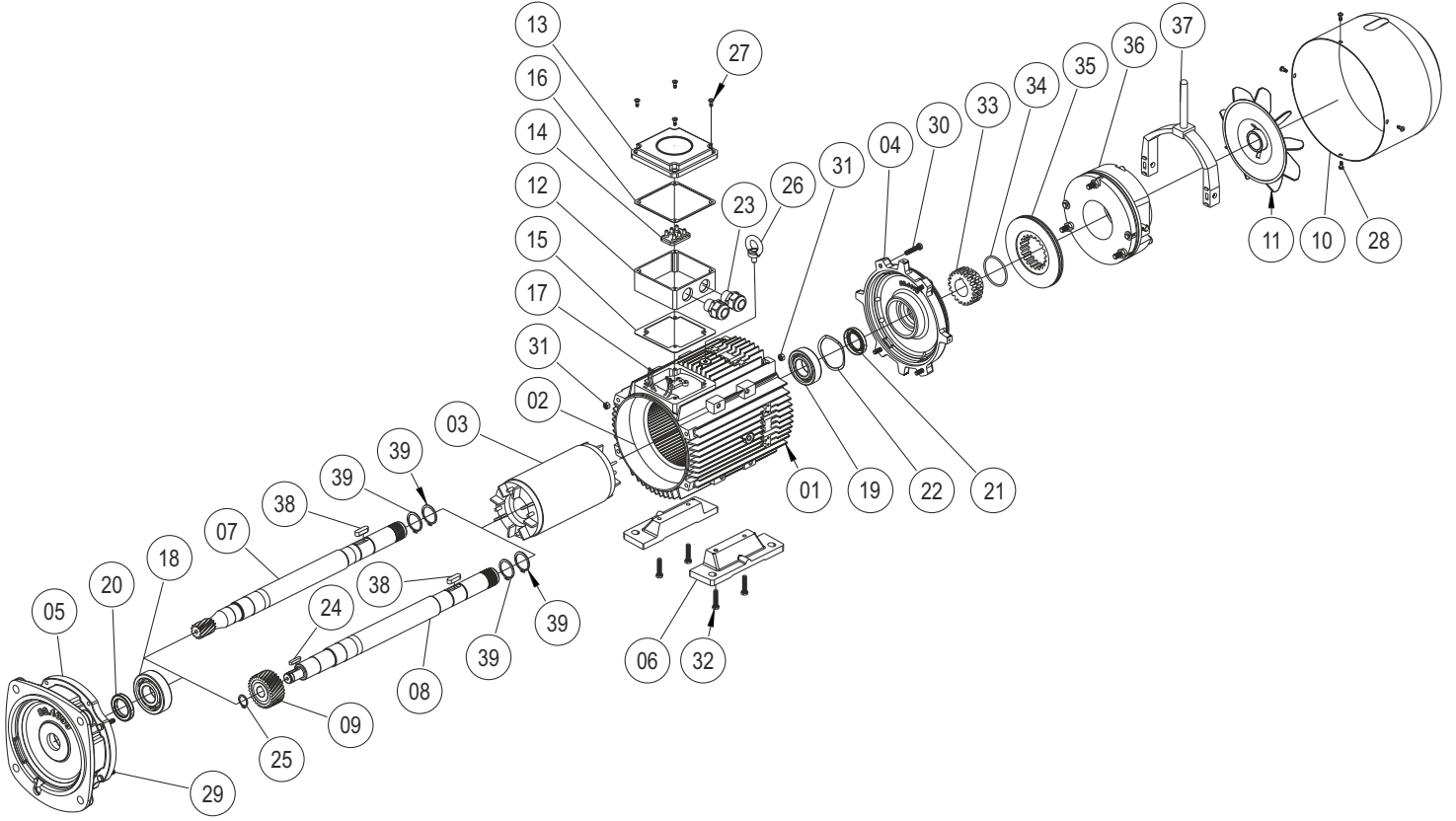

01	Gövde	01	Housing	21	Keçe (Arka)	21	Seal Ring (Back)
02	Sargılı Stator	02	Wound Stator	22	Rulman Gergi Yayı	22	Bearing Shim
03	Rotor	03	Rotor	23	Rakor	23	Conduit
04	Fren Flaşı	04	Brake Connection Flange	24	Kama	24	Key
05	PGR Motor Bağlantı Flaşı	05	Motor Connection Flange	25	Segman	25	Circilip DIN 471
06	Ayak	06	Foot	26	Mapa	26	Eye Bolt
07	Motor Mili (Yekpare)	07	Drive Shaft (Gearcut)	27	Yıldız Başlı Civata	27	Pan Head Secrews
08	Motor Mili (Çakma)	08	Drive Shaft (Plain)	28	Yıldız Başlı Civata	28	Pan Head Secrews
09	Z1 Dişlisi	09	Z1 Gear	29	Civata DIN 933	29	Bolt
10	Fan Kapağı	10	Fan Cover	30	Civata DIN 933	30	Bolt
11	Fan	11	Fan	31	Somun	31	Nut
12	Terminal Kutusu	12	Terminal Box	32	Civata DIN 933	32	Bolt
13	Terminal Kutu Kapağı	13	Terminal Box Cover	33	Fren Kaplini	33	Coupling
14	Klemens Plakası	14	Terminal Plate	34	O-Ring	34	O-Ring
15	Terminal Contası Alt	15	Terminal Gasket Down	35	Fren Balatası	35	Brake Lining
16	Terminal Contası Üst	16	Terminal Gasket Up	36	Fren	36	Brake
17	Kablo Grubu	17	Lead Cables	37	Manuel Kolu	37	Hand Release
18	Ön Rulman	18	Bal Bearing (Drive-Side)	38	Kama	38	Key
19	Arka Rulman	19	Bal Bearing (Non-Drive-Side)	39	Segman	39	Circilip DIN 471
20	Keçe (Ön)	20	Seal Ring (Front)				

B3-B5-B14 FLANŞLI MOTOR PARÇA LİSTESİ / B3-B5-B14 FLANGE MOTOR PART LIST

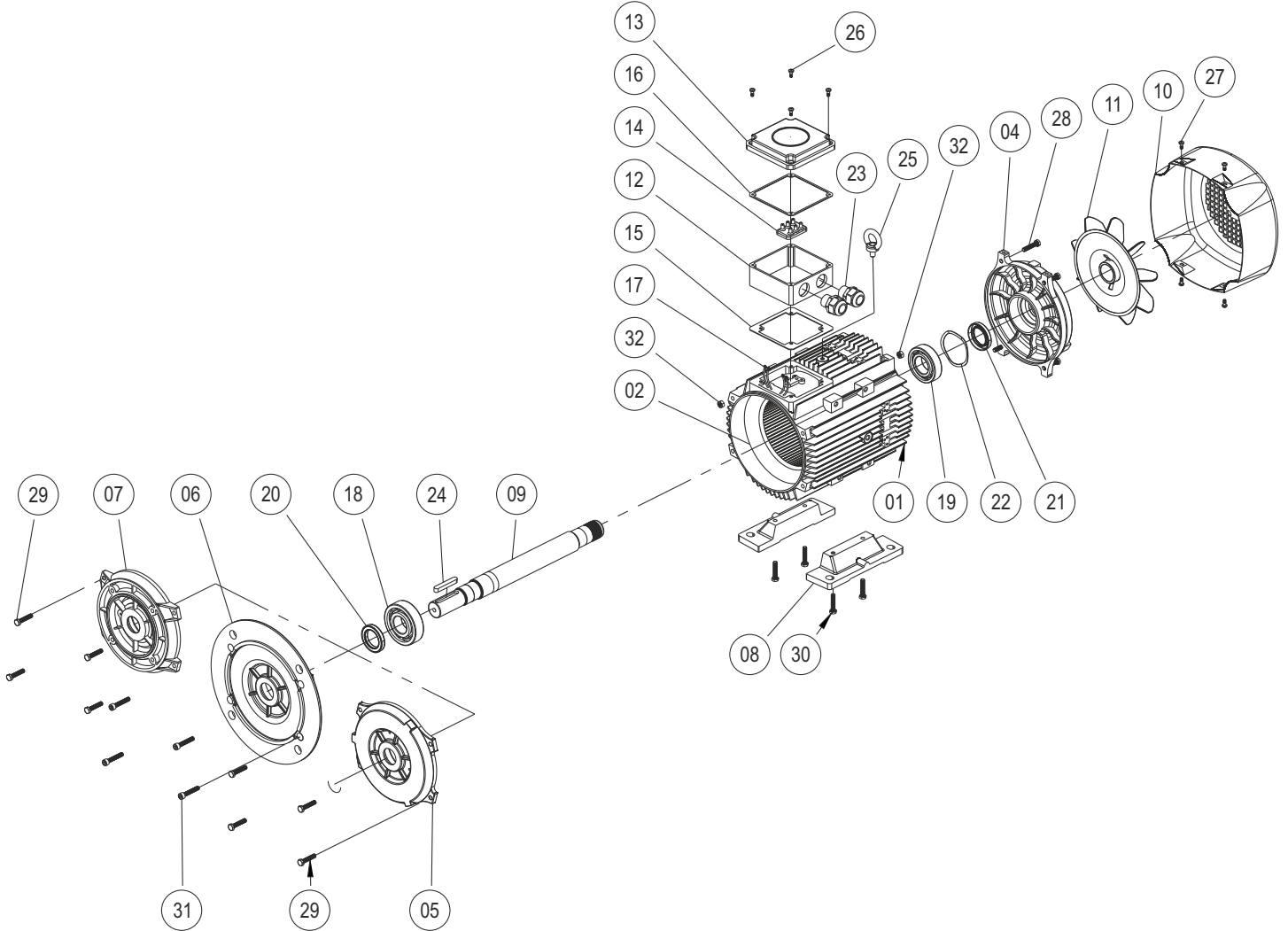

01	Gövde	01	Housing	17	Kablo Grubu /	17	Lead Cables
02	Sargılı Stator	02	Wound Stator	18	Ön Rulman /	18	Bal Bearing (Drive-Side)
03	Rotor	03	Rotor	19	Arka Rulman /	19	Bal Bearing (Non-Drive-Side)
04	Motor Arka Kapağı	04	Nondrive - Endshield	20	Keçe (Ön) /	20	Seal Ring (Front)
05	B3 Motor Bağlantı Flanşı	05	Flange	21	Keçe (Arka) /	21	Seal Ring (Back)
06	B5 Motor Bağlantı Flanşı	06	Flange	22	Rulman Gergi Yayı /	22	Bearing Shim
07	B14 Motor Bağlantı Flanşı	07	Flange	23	Rakor /	23	Conduit
08	Ayak	08	Foot	24	Kama /	24	Key
09	Motor Mili (Standart)	09	Drive Shaft (Gearcut)	25	Mapa /	25	Eye Bolt
10	Fan Kapağı	10	Fan Cover	26	Yıldız Başlı Civata /	26	Pan Head Secrews
11	Fan	11	Fan	27	Yıldız Başlı Civata /	27	Pan Head Secrews
12	Terminal Kutusu	12	Terminal Box	28	Civata DIN 933 /	28	Bolt
13	Terminal Kutu Kapağı	13	Terminal Box Cover	29	Civata DIN 933 /	29	Bolt
14	Klemens Plakası	14	Terminal Plate	30	Civata DIN 933 /	30	Bolt
15	Terminal Contası Alt	15	Terminal Gasket Down	31	Civata DIN 912 /	31	Bolt
16	Terminal Contası Üst	16	Terminal Gasket Up	32	Somun /	32	Nut

FRENLİ B3-B5-B14 FLANŞLI MOTOR PARÇA LİSTESİ / BRAKE B3-B5-B14 FLANGE MOTOR PART LIST

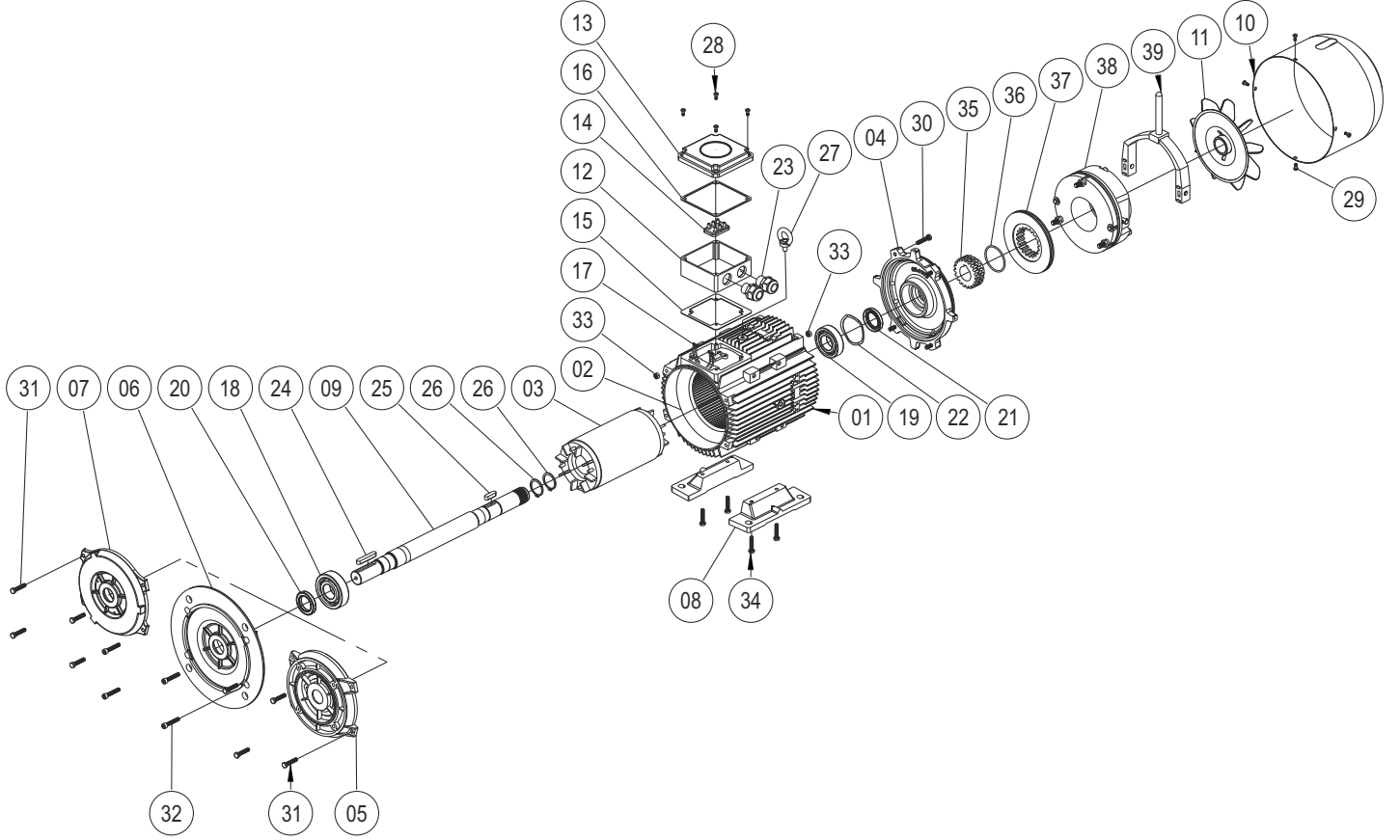

01	Gövde	01	Housing	21	Keçe (Arka)	21	Seal Ring (Back)
02	Sargılı Stator	02	Wound Stator	22	Rulman Gergi Yayı	22	Bearing Shim
03	Rotor	03	Rotor	23	Rakor	23	Conduit
04	Fren Flanşı	04	Brake Connection Flange	24	Kama	24	Key
05	B3 Motor Bağlantı Flanşı	05	Flange	25	Kama	25	Key
06	B5 Motor Bağlantı Flanşı	06	Flange	26	Segman	26	Circilip DIN 471
07	B14 Motor Bağlantı Flanşı	07	Flange	27	Mapa	27	Eye Bolt
08	Ayak	08	Foot	28	Yıldız Başlı Civata	28	Pan Head Secrews
09	Motor Mili (Standart)	09	Drive Shaft (Gearcut)	29	Yıldız Başlı Civata	29	Pan Head Secrews
10	Fan Kapağı	10	Fan Cover	30	Civata DIN 933	30	Bolt
11	Fan	11	Fan	31	Civata DIN 933	31	Bolt
12	Terminal Kutusu	12	Terminal Box	32	Civata DIN 912	32	Bolt
13	Terminal Kutu Kapağı	13	Terminal Box Cover	33	Somun	33	Nut
14	Klemens Plakası	14	Terminal Plate	34	Civata DIN 933	34	Bolt
15	Terminal Contası Alt	15	Terminal Gasket Down	35	Fren Kaplini	35	Brake Coupling
16	Terminal Contası Üst	16	Terminal Gasket Up	36	O-Ring	36	O-Ring
17	Kablo Grubu	17	Lead Cables	37	Fren Balatası	37	Brake Lining
18	Ön Rulman	18	Bal Bearing (Drive-Side)	38	Fren	38	Brake
19	Arka Rulman	19	Bal Bearing (Non-Drive-Side)	39	Manuel Kolu	39	Hand Release
20	Keçe (Ön)	20	Seal Ring (Front)				

MOTOR PARÇA LİSTESİ / THE MOTOR PART LIST

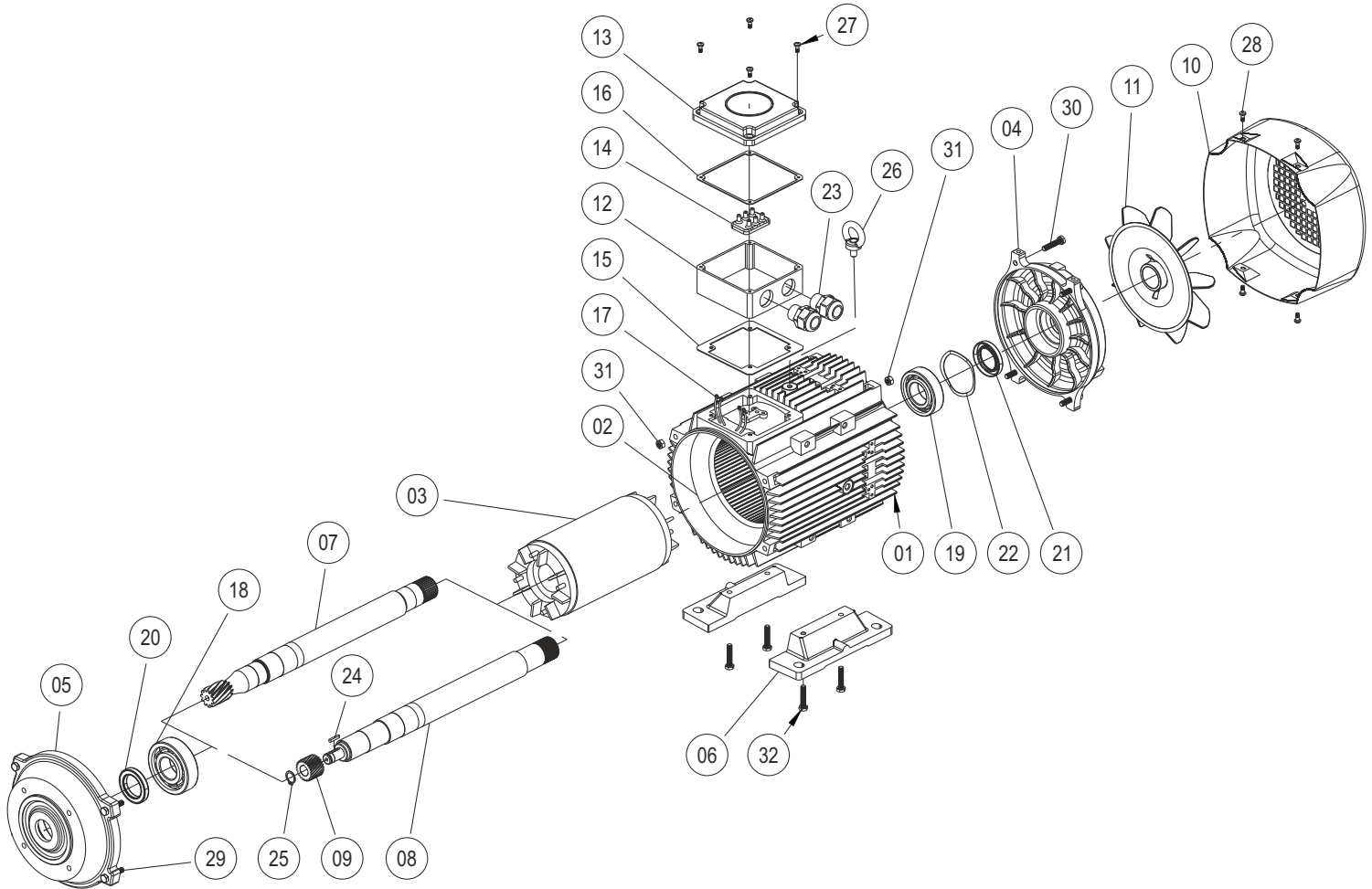

01	Gövde	01	Housing	17	Kablo Grubu	17	Lead Cables
02	Sargılı Stator	02	Wound Stator	18	Ön Rulman	18	Bal Bearing (Drive-Side)
03	Rotor	03	Rotor	19	Arka Rulman	19	Bal Bearing (Non-Drive-Side)
04	Motor Arka Kapağı	04	Nondrive - Endshield	20	Keçe (Ön)	20	Seal Ring (Front)
05	PGR Motor Bağlantı Flanşı	05	Moter Connection Flange	21	Keçe (Arka)	21	Seal Ring (Back)
06	Ayak	06	Foot	22	Rulman Gergi Yayı	22	Bearing Shim
07	Motor Mili (Yekpare)	07	Drive Shaft (Gearcut)	23	Rakor	23	Conduit
08	Motor Mili (Çakma)	08	Drive Shaft (Plain)	24	Kama	24	Key
09	Z1 Dişlisi	09	Z1 Gear	25	Segman	25	Circilip DIN 471
10	Fan Kapağı	10	Fan Cover	26	Mapa	26	Eye Bolt
11	Fan	11	Fan	27	Yıldız Başlı Civata	27	Pan Head Secrews
12	Terminal Kutusu	12	Terminal Box	28	Yıldız Başlı Civata	28	Pan Head Secrews
13	Terminal Kutu Kapağı	13	Terminal Box Cover	29	Civata DIN 933	29	Bolt
14	Klemens Plakası	14	Terminal Plate	30	Civata DIN 933	30	Bolt
15	Terminal Contası Alt	15	Terminal Gasket Down	31	Somun	31	Nut
16	Terminal Contası Üst	16	Terminal Gasket Up	32	Civata DIN 933	32	Bolt

FRENLİ MOTOR PARÇA LİSTESİ / THE MOTOR PART LIST WITH BRAKE

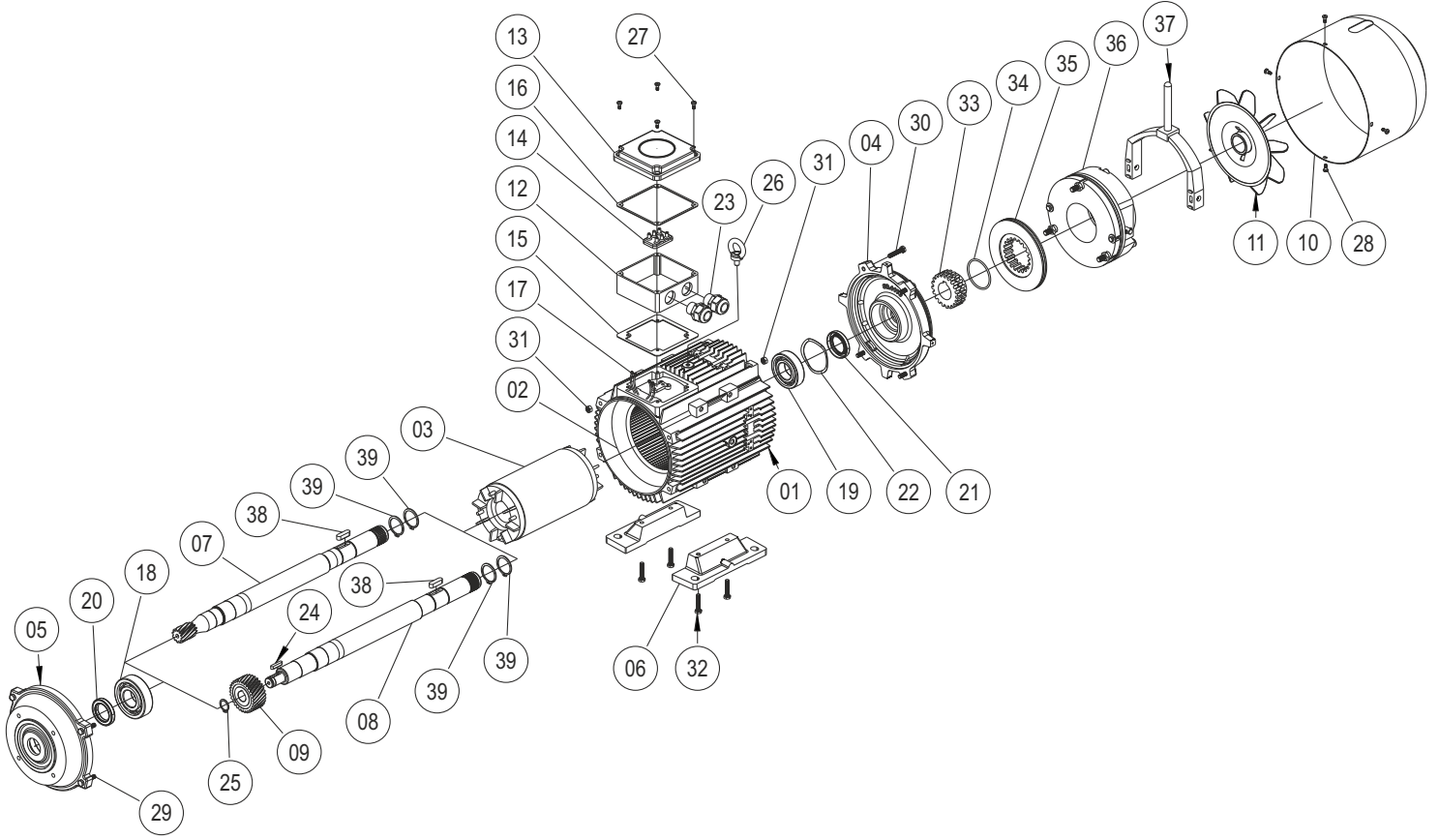

01	Gövde	01	Housing	21	Keçe (Arka)	21	Seal Ring (Back)
02	Sargılı Stator	02	Wound Stator	22	Rulman Gergi Yayı	22	Bearing Shim
03	Rotor	03	Rotor	23	Rakor	23	Conduit
04	Fren Flanşı	04	Brake Connection Flange	24	Kama	24	Key
05	PGR Motor Bağlantı Flanşı	05	Flange	25	Segman	25	Circilip DIN 471
06	Ayak	06	Foot	26	Mapa	26	Eye Bolt
07	Motor Mili (Yekpare)	07	Drive Shaft (Gearcut)	27	Yıldız Başlı Civata	27	Pan Head Secrews
08	Motor Mili (Çakma)	08	Drive Shaft (Plain)	28	Yıldız Başlı Civata	28	Pan Head Secrews
09	Z1 Dişlisi	09	Z1 Gear	29	Civata DIN 933	29	Bolt
10	Fan Kapağı	10	Fan Cover	30	Civata DIN 933	30	Bolt
11	Fan	11	Fan	31	Somun	31	Nut
12	Terminal Kutusu	12	Terminal Box	32	Civata DIN 933	32	Bolt
13	Terminal Kutu Kapağı	13	Terminal Box Cover	33	Fren Kaplini	33	Coupling
14	Klemens Plakası	14	Terminal Plate	34	O-Ring	34	O-Ring
15	Terminal Contası Alt	15	Terminal Gasket Down	35	Fren Balatası	35	Brake Lining
16	Terminal Contası Üst	16	Terminal Gasket Up	36	Fren	36	Brake
17	Kablo Grubu	17	Lead Cables	37	Manuel Kolu	37	Hand Release
18	Ön Rulman	18	Bal Bearing (Drive-Side)	38	Kama	38	Key
19	Arka Rulman	19	Bal Bearing (Non-Drive-Side)	39	Segman	39	Circilip DIN 471
20	Keçe (Ön)	20	Seal Ring (Front)				

- | | |
|-----------------------|------------------|
| 1 Elektro mıknatıs | 1 Electromagnet |
| 2 Endüvi plakası | 2 Armature plate |
| 3 Tork yayı | 3 Torque springs |
| 4 Disk | 4 Disc |
| 5 Kamalı burç | 5 Splined hub |
| 6 O-ring | 6 O-ring |
| 7 Ayar halkası | 7 Adjuster rings |
| 8 Ayar somunu | 8 Adjuster nuts |
| 9 Bağlantı civataları | 9 Fixing screws |

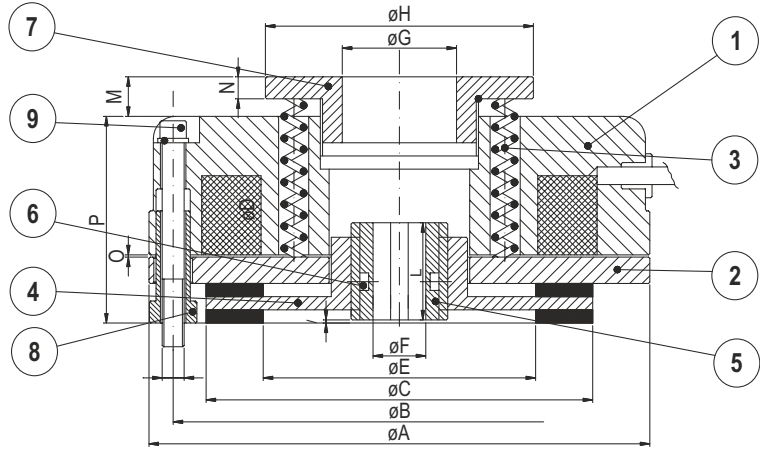

Tip / Type Fren Modeli / Brake Model	K1	K2	K3	K4	K5	K6	K7	K7/D	K8	K8/D	K9	K9/D	K9/T
Statik Fren Momenti Static Braking Torque (Nm)	5	12	16	20	40	60	90	180	200	400	300	600	900
Motorun Max. Hızı Max Speed of the motor (rpm)	3000	3000	3000	3000	3000	3000	3000	3000	1500	1500	1500	1500	1500
Giriş Gücü Input Power (W)	15	20	25	30	45	50	55	55	60	60	65	65	65
Max. Ses Max noisiness (≤dB-A)	68	69	68	69	70	70	70	70	70	69	69	69	70
Ağırlık Weight (Kg.)	1,1	1,85	2,55	2,84	4,8	7	12	15	14,3	18	23	28	34
A	84	104	114	124	148	159	189	189	218	218	248	248	248
B	72	90	103	112	132	145	170	170	196	196	230	230	230
C	61	77	88	98	119	128	151	151	176	176	204	204	204
D	3xM4	3xM5	3xM5	3xM6	3xM6	3xM8	3xM8	3xM8	6xM10	6xM10	6xM10	6xM10	9xM10
Delik toleransı K3'e kadar H7, diğerleri + 0,01/-0,01 Tolerance hole till size K3 H7, others + 0,01/-0,01	E	35	44	62	69	79	80	90	90	103	103	132	132
F	10-11 12	11-14 15	11-15	14-25	24-25 28	25-30 34	25-30 34	25 H40 34 H60	24-34	34 H60 48	44-45 48	44-45 48	44-45 48-50
G	20	26	26	42	60	60	60	60	60	60	60	60	60
H	50	61	61	79	104	104	104	104	104	104	104	104	104
I	1,5	1,5	1,5	1,5	1,5	1,5	1,5	1,5	1,5	1,5	1,5	1,5	1,5
L	18	20	20	20	25	30	30	60	40	60	40	60	80
M (max)	9	9	9	9,5	18	16	14	14	18	18	18	18	18
N	4	4	4	5,5	8	8	8	8	8	8	8	8	8
O	0,2	0,2	0,2	0,2	0,3	0,3	0,3	0,3	0,3	0,4	0,4	0,4	0,4±0,5
P	38,5	41,5	47	46,5	64	69,5	79	101,5	78	98	80	105	130

Not : Fren çalıştırılmadan önce statik fren momenti tabloda verilen değerlere göre ± % 20 değişiklik gösterebilir.
Note : The brake before running in, the static braking torque value could change by +20% from the reported value.