

Pressure Relief Valve

FIG. 1321-300

Specifications

- Pressure Relief Valve: Limits pipe line pressure by release excess pressure.
 - Pressure sustaining: Prevents pipe line pressure from rising to a maximum value.
 - Operates over a wide flow range.
 - Set pressure is adjustable with single screw.
 - Can be maintained without removal from the pipe line.
 - Flanged to EN1092-2 PN10/PN16, ANSI B16.1 Class125. (Other available on request)
 - Grooved ends to AWWA C606 Standard.
 - Adjustment range of set pressure: 65 to 180 psi.
- FM Approved.

Working Pressure and Temperature

- 300 psi @ 0°C to 87°C.

Corrosion Protection

- Fusion bonded coating interior and exterior meet or exceed all applicable of AWWA C550 standard.

Material Specifications

Part	Material	ASTM Specification
Body	Ductile Iron	A536 Grade 65-45-12
Bonnet	Ductile Iron	A536 Grade 65-45-12
Diaphragm	Nylon Reinforced Natural Rubber	
Spring Retainer	Ductile Iron	A536 Grade 65-45-12
Spring	Stainless Steel	A276 Grade 304
Galvanized Bolt	Carbon Steel	A307 Grade B
Galvanized Washer	Carbon Steel	A307 Grade B

Main Dimensions (mm/inch)

Size	2	2.5	3	4	5
L	233/9	290/11.5	310/12.2	356/14	370/14.5
Size	6	8	10	12	
L	436/17.2	530/20.8	636/25	835/32.8	

Schematic

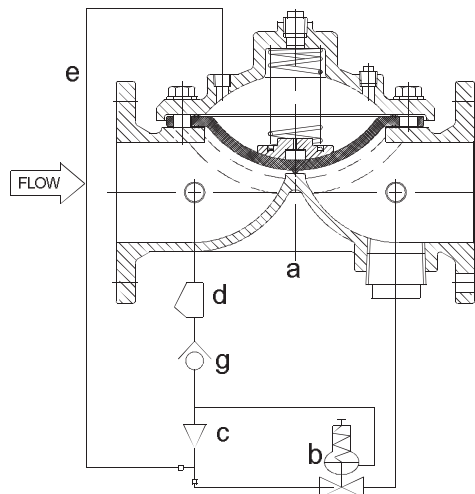

NO.	Components	NO.	Components
a	Main Valve	d	Y-Strainer
b	Pressure Reducing Pilot	e	Pipeline
c	Restriction Orifice	g	Check Valve

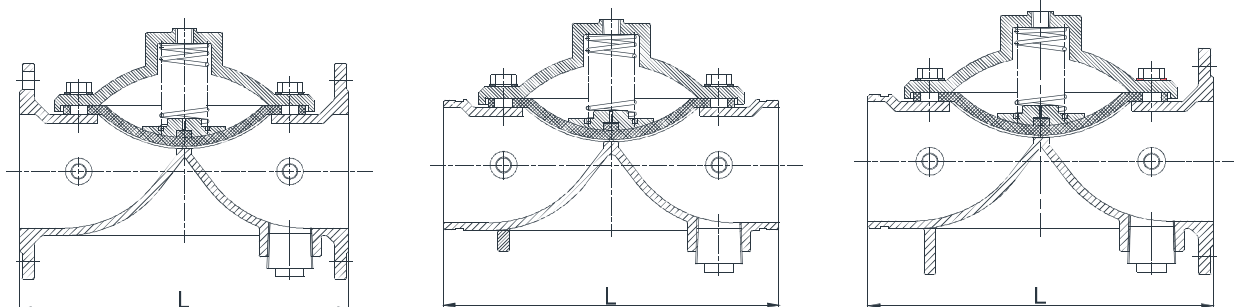

Notes

- Designs, materials and specifications shown are subject to change without notice due to the continuous development of our products.