

Picture is showing a SG600

## A perfect power package

You deserve a genset you can rely on. A dependable power plant delivering maximum uptime, low operational costs and long-term profitability.

The Scania Gensets are engineered with all this in mind. The result: A comprehensive range of extremely reliable and fuel efficient power packages. All of them built around the latest generation of Scania diesels; impressive engines having proven their skills and endurance in all kinds of climates and environments.

Every Scania Genset is an integrated, ready-to-run solution with true Scania quality in every detail – from the cutting-edge diesel engine and alternator, to the sophisticated digital control interface. All in all, our gensets are solid performers providing high efficiency, reduced emissions and low life-cycle-costs.

The Scania Genset comes in two types to perfect fit your application.

### PRP - Prime power

For continuous operation and unlimited yearly operation time at varying load. Max mean load factor of 70% of rated power over 24 h of operation. 1 hour/12 hours period of accumulated peak overload to 110%. Available for Fuel optimized gensets.

### ESP - Standby power

This rating is for the supply of continuous electrical power (at variable load) in the event of a reliable utility power failure. No overload is permitted.

Available for Fuel optimized gensets.

Genset type	SG715	SG715
Application	PRP	ESP
50Hz, 380-415 V	650 kVA 520 kW <sub>e</sub>	715 kVA 572 kW <sub>e</sub>
	Ratings at 0.8 pf	

Genset images may include optional extras.



# SCANIA GENSET SG715

Genset specification	Unit	50Hz, 1,500rpm Fuel optimized
Scania engine type		DC16 078A
Number of cylinders		V 8
Displacement	litre	16,4
Aspiration		Turbocharged
Alternator		Stamford
Frequency	Hz	50
Engine speed	rpm	1,500
Fuel tank capacity	litre	965

### Fuel consumption (PRP)

100%	L/h	144
75%	L/h	97
50%	L/h	65

### Technical data

Heat rejection to exhaust system	kW	382
Heat rejection to cooling system	kW	186
Exhaust temperature	°C	499
Combustion air flow	kg/min	42

### Dimensions

Length (A)	mm	3900
Width (B)	mm	1316
Height (C)	mm	2248

### Weight

Incl. coolant and oil, excl. batteries and fuel	kg	4155
---	----	------

### \*To be decided

**Test conditions** Air temperature +25°C. Barometric pressure 100 kPa (750 mmHg). Humidity 30%. Diesel fuel acc. to ECE R 24 Annex 6. Density of fuel 0.840 kg/dm<sup>3</sup>. Viscosity of fuel 3.0 cSt at 40°C. Energy value 42700 kJ/kg. **Power test code** ISO 3046. Power and fuel values ±3%.

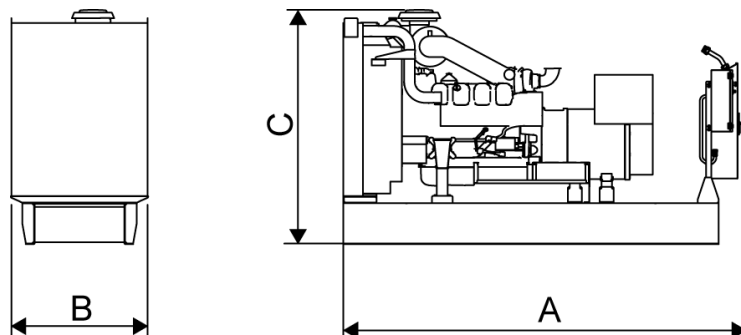

# SCANIA

SE 151 87 Södertälje, Sweden  
 Telephone +46 8 553 810 00  
 Telefax +46 8 553 829 93  
 www.scania.com  
 engines@scania.com



## A perfect power package

You deserve a genset you can rely on. A dependable power plant delivering maximum uptime, low operational costs and long-term profitability.

The Scania Gensets are engineered with all this in mind. The result: A comprehensive range of extremely reliable and fuel efficient power packages. All of them built around the latest generation of Scania diesels; impressive engines having proven their skills and endurance in all kinds of climates and environments.

Every Scania Genset is an integrated, ready-to-run solution with true Scania quality in every detail – from the cutting-edge diesel engine and alternator, to the sophisticated digital control interface. All in all, our gensets are solid performers providing high efficiency, reduced emissions and low life-cycle-costs.

The Scania Genset comes in two types to perfect fit your application.

### PRP - Prime power

For continuous operation and unlimited yearly operation time at varying load. Max mean load factor of 70% of rated power over 24 h of operation. 1 hour/12 hours period of accumulated peak overload to 110%. Available for Fuel optimized gensets.

### ESP - Maximum stand-by power

This rating is for the supply of continuous electrical power (at variable load) in the event of a reliable utility power failure. No overload is permitted.

Available for Fuel optimized gensets.

Genset type	SG715	SG715
Application	PRP	ESP
50Hz, 380-415 V	650 kVA 520 kW <sub>e</sub>	715 kVA 572 kW <sub>e</sub>
	Ratings at 0.8 pf	

Genset images may include optional extras.



# SCANIA GENSET SG715

Genset specification	Unit	50Hz, 1,500rpm Fuel optimized
Scania engine type		DC16 078A
Number of cylinders		V8
Displacement	litre	16.4
Aspiration		Turbocharged
Alternator		Stamford
Frequency	Hz	50
Engine speed	rpm	1,500
Fuel tank capacity	litre	1200

### Fuel consumption (PRP)

100%	L/h	132
75%	L/h	97
50%	L/h	65

### Technical data

Heat rejection to exhaust system	kW	382
Heat rejection to cooling system	kW	186
Exhaust temperature	°C	499
Combustion air flow	kg/min	42

### Dimensions

Length (A)	mm	5400
Width (B)	mm	1750
Height (C)	mm	2100
Total height of exhaust rain cap (D)	mm	2163
Max horizontal projection of end door (E)	mm	1108
Max horizontal projection of doors at each side (F)	mm	1108

### Weight

Incl. coolant and oil, excl. batteries and fuel	kg	6710
---	----	------

**Test conditions** Air temperature +25°C. Barometric pressure 100 kPa (750 mmHg). Humidity 30%. Diesel fuel acc. to ECE R 24 Annex 6. Density of fuel 0.840 kg/dm<sup>3</sup>. Viscosity of fuel 3.0 cSt at 40°C. Energy value 42700 kJ/kg. **Power test code** ISO 3046. Power and fuel values ±3%.

