

# VAMP 57

Protection IED

Publication version: V57/en QS/A007

Quick Start



Trace back information:  
Workspace Main version a123  
Checked in 2016-10-05  
Skribenta version 4.6.006

## Table of Contents

<b>1</b>	<b>Legal notice</b> .....	<b>5</b>
<b>2</b>	<b>Safety information and password protection</b> .....	<b>6</b>
<b>3</b>	<b>General</b> .....	<b>8</b>
3.1	EU directive compliance .....	8
3.2	Relay packing .....	8
3.3	Identification .....	9
3.4	Storage .....	9
3.5	Checking of the consignment .....	10
3.6	Warranty .....	10
3.7	Complaints .....	10
<b>4</b>	<b>Safety</b> .....	<b>11</b>
4.1	Electrical safety .....	11
4.2	Relay handling .....	11
4.3	Electrostatic discharge .....	11
<b>5</b>	<b>Wiring</b> .....	<b>12</b>
5.1	General .....	12
5.2	Connections .....	12
5.3	Checking the wiring .....	13
5.4	Electrical connections .....	13
<b>6</b>	<b>Energizing</b> .....	<b>14</b>
<b>7</b>	<b>Local HMI</b> .....	<b>15</b>
<b>8</b>	<b>VAMPSET</b> .....	<b>19</b>
8.1	VAMPSET setting and configuration tool .....	19
8.1.1	Folder view .....	19
8.2	Configuring the system with VAMPSET .....	20
8.2.1	Setting up the communication .....	21
8.2.2	Writing the settings to the IED .....	21
8.2.3	Saving the VAMPSET document file .....	22
<b>9</b>	<b>Relay features</b> .....	<b>23</b>
9.1	User interface .....	24
<b>10</b>	<b>Connections</b> .....	<b>25</b>
10.1	Rear panel .....	25
10.2	Local port (Front panel) .....	41
<b>11</b>	<b>Block diagram</b> .....	<b>42</b>

<b>12 Mounting .....</b>	<b>44</b>
<b>13 Related documents .....</b>	<b>45</b>

# 1 Legal notice

## **Copyright**

2016 Schneider Electric. All rights reserved.

## **Disclaimer**

No responsibility is assumed by Schneider Electric for any consequences arising out of the use of this document. This document is not intended as an instruction manual for untrained persons. This document gives instructions on device installation, commissioning and operation. However, the manual cannot cover all conceivable circumstances or include detailed information on all topics. In the event of questions or specific problems, do not take any action without proper authorization. Contact Schneider Electric and request the necessary information.

## **Contact information**

35 rue Joseph Monier

92506 Rueil-Malmaison

FRANCE

Phone: +33 (0) 1 41 29 70 00

Fax: +33 (0) 1 41 29 71 00

# 2

## Safety information and password protection

### Important Information

Read these instructions carefully and look at the equipment to become familiar with the device before trying to install, operate, service or maintain it. The following special messages may appear throughout this bulletin or on the equipment to warn of potential hazards or to call attention to information that clarifies or simplifies a procedure.



The addition of either symbol to a “Danger” or “Warning” safety label indicates that an electrical hazard exists which will result in personal injury if the instructions are not followed.



This is the safety alert symbol. It is used to alert you to potential personal injury hazards. Obey all safety messages that follow this symbol to avoid possible injury or death.

### **⚠ DANGER**

**DANGER** indicates an imminently hazardous situation which, if not avoided, **will result in** death or serious injury.

### **⚠ WARNING**

**WARNING** indicates a potentially hazardous situation which, if not avoided, **can result in** death or serious injury.

### **⚠ CAUTION**

**CAUTION** indicates a potentially hazardous situation which, if not avoided, **can result in** minor or moderate injury.

### **NOTICE**

**NOTICE** is used to address practices not related to physical injury.

### **User qualification**

Electrical equipment should be installed, operated, serviced, and maintained only by trained and qualified personnel. No responsibility is assumed by Schneider Electric for any consequences arising out of the use of this material. A qualified person is one who has skills and knowledge related to the construction, installation, and operation of electrical equipment and has received safety training to recognize and avoid the hazards involved.

### **Password protection**

Use IED's password protection feature in order to protect untrained person interacting this device.

<b>⚠ WARNING</b>
<b>WORKING ON ENERGIZED EQUIPMENT</b> Do not choose lower Personal Protection Equipment while working on energized equipment. <b>Failure to follow these instructions can result in death or serious injury.</b>

## 3 General

This manual contains instructions for unpacking, handling, mounting and wiring of VAMP protection relays.

For more details, please see from the latest user manual, V57\_EN\_M\_xxxx.

Carefully read through the handling instruction of this manual before undertaking any mounting or wiring work.

### 3.1 EU directive compliance

#### EMC compliance

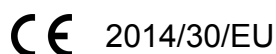

Compliance with the European Commission's EMC Directive. Product Specific Standards were used to establish conformity:

- EN 60255-26: 2013

#### Product safety

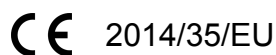

Compliance with the European Commission's Low Voltage Directive. Compliance is demonstrated by reference to generic safety standards:

- EN60255-27:2014

### 3.2 Relay packing

The relay packing can be stored and reused when needed. The packing itself is not a suitable transport package, but the relay must be further packed as required by the means of transportation to be used.

The packing material is recyclable and can be disposed of or recycled according to separate recycling instructions.



## 3.3 Identification

Each VAMP 57 unit is delivered in a separate package containing:

- 1 pc VAMP 57 unit
- Calibration and Test Report
- Terminal blocks are attached to terminals X2, X3, X4 and X5 of the VAMP 57 unit

Optional accessories are delivered in separate packages.

To identify a VAMP unit, inspect the labels which are visible in the package and on the side of the relay unit.

- Example of the label attached to the side of the unit



- |  |                          |                              |
|--|--------------------------|------------------------------|
| 1. Rated voltage $U_N$                   | 2. Rated frequency $f_N$ | 3. Rated phase current $I_N$ |
| 4. Rated residual current $I_0$          | 5. Power consumption     | 6. Rated voltage $U_{AUX}$   |
| 7. Type designation                      | 8. Serial number         | 9. Manufacturing date        |
| 10. MAC address for TCP/IP communication | 11. VAMP identification  |                              |

- Example of the label attached to the cartridge package

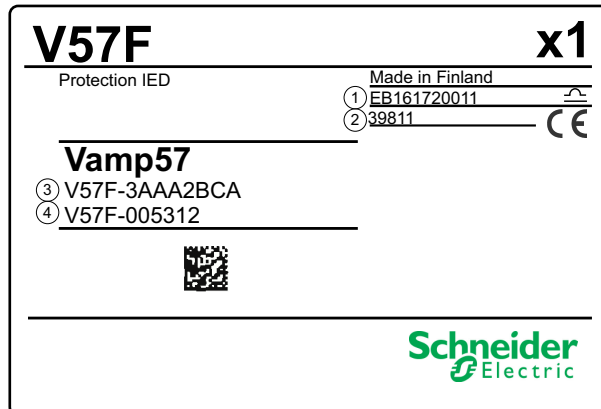

- |                     |                                  |
|---------------------|----------------------------------|
| 1. Serial number    | 2. Customer order code reference |
| 3. Type designation | 4. VAMP identification           |

## 3.4 Storage

To prevent the possible ingress of dirt, the packing should not be opened until the relay is to be used. Long time storage shall be made in dry place.

---

## 3.5 Checking of the consignment

1. Check the device visually for possible external damage or loose parts inside the device. If the device is found to be damaged, see section “Complaints”
2. Check that the device complies with the order and the Calibration and Test Report
  - relay type, serial number
  - other possible order-related structural matters.If found incomplete, see section “Complaints”

## 3.6 Warranty

For information on the warranty contact your sales representative.

## 3.7 Complaints

Complaints for manufacturing faults are directed in writing to the relay manufacturer or the authorized dealer, from which the product was acquired. Find more information from our customers care center

Complaints about transport damage must be sent to the accountable transport or insurance company.

## **4 Safety**

When mounted into the specific environment the relays express safety in operation. See details in the Technical description of the specific relay.

### **4.1 Electrical safety**

National electrical safety regulations must be observed, when work is carried out under live conditions. The relay manufacturer cannot be held responsible for accidents caused by incorrect working or protection practices.

### **4.2 Relay handling**

The correct handling of the relays under all mounting and operating conditions forms the foundation for a correct and safe use of the devices. All separately marked notes and warnings **MUST** be observed.

### **4.3 Electrostatic discharge**

The relays include components, which are liable to be damaged by electrostatic discharge (ESD). The relays must not be opened without permission from the manufacturer. If done, necessary protective measures against ESD should be taken.

---

# 5 Wiring

## 5.1 General

The wiring work must be performed according to national standards and possible requirements from the customer.

Incoming and outgoing wires are connected to the screw terminals on the rear panel of the relay. The terminals are detachable, except those of the voltage input and current inputs, terminal X1 on VAMP 57.

Configuration of and communication with the relay on the local level can be carried out with a PC connected to the LOCAL USB port of the relay.

The communication interface on rear panel (RS-485 interface or two RJ-45 Ethernet connectors) in terminal X4 is used for communication with higher-level systems, e.g. control systems.

## 5.2 Connections

1. Check that the rated values of the relay comply with those of the intended application.
  - The rated values of the relay can be found from the serial number sticker.
  - Check that the rated values of the voltage and current transformer secondaries comply with those of the relay.
  - Check that the load ability of the outputs is adequate.
2. Earth the relay by connecting an earthing wire (minimum cross section 2.5 mm<sup>2</sup>) to the relays earth terminal.
3. Wire the relay to the rest of the process according to the wiring diagrams of the application.
4. Connect the cable shields of shielded signal cables to the earth terminal of the relay.

## 5.3 Checking the wiring

Check the secondary wiring by visual inspection and, when needed, by measuring, to eliminate possible incorrect wirings, which may cause malfunction of the relay or associated devices.

### By visual inspection

1. Perform visual inspection of the wiring. Especially check the wire bunches for adequate slack where needed over hinges.
2. Check the screw terminals for correct tightness.
3. Check, that no wire strands are protruding from the terminals.

### By measuring

1. Check the connections between the relay and associated devices by using a circuit indicator lamp or buzzer.
2. Check other possible connections by using recognized and reliable working practices.

## 5.4 Electrical connections

**Table 5.1: Terminal number**

Terminal number	X1	X2	X3	X4	X5
Screw clamp:					
Maximum wire dimension, mm <sup>2</sup> (AWG)	4.0 (11 – 12)	2.5 (13 – 14)	2.5 (13 – 14)	2.5 (13 – 14)	2.5 (13 – 14)
Terminal type	Fixed	MSTB2.5 – 5.08	MSTB2.5 – 5.08	MSTB2.5 – 5.08	MSTB2.5 – 5.08
Wire type	Solid or stranded				
Ring-lug:					
Ring lug width (mm) and screw size	8.0, M3.5				7.0, M3.5
Wire type	Solid or stranded				

# 6 Energizing

The external auxiliary voltage  $U_{AUX}$  (40 – 265 V ac or V dc, or optionally 18 – 36V dc) for the relay is connected to the pins X2: 1 – 2.

**NOTE:** When optional 18 – 36 Vdc power module is used the polarity is as follows: X2:1 positive (+), X2:2 negative (-).

After VAMP 57 is switched on, it performs the following initialization sequence, which takes approximately 5 seconds:

- Power LED ON, “Starting ..” on screen
- Watchdog contact picks up

The first screen displayed at the end of the sequence is the Mimic view screen.

# 7 Local HMI

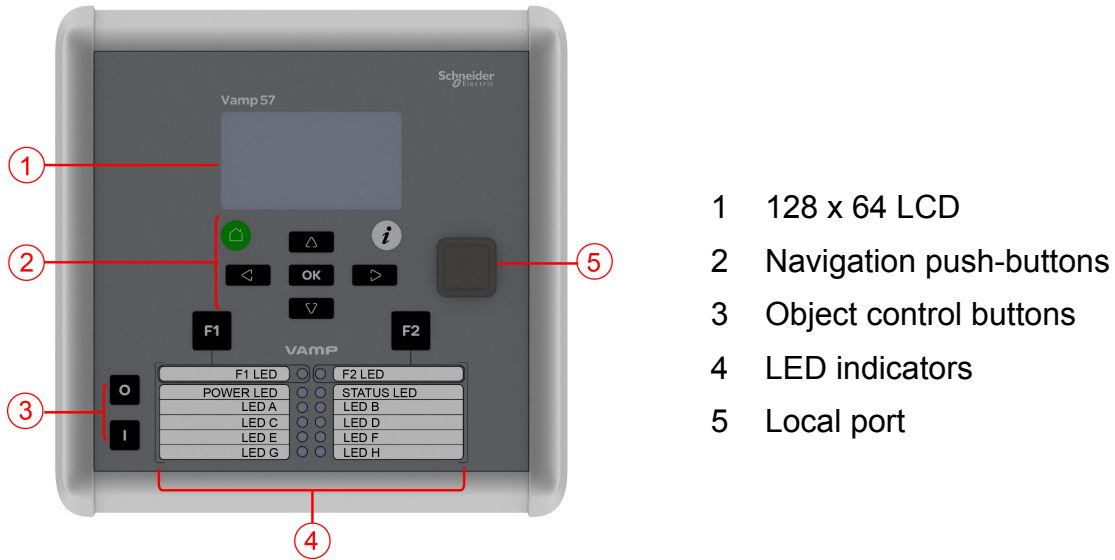

Figure 7.1: VAMP 57 local HMI

## Push-buttons

### Symbol Function



CANCEL push-button for returning to the previous menu. To return to the first menu item in the main menu, press the button for at least three seconds.



INFO push-button for viewing additional information, for entering the password view and for adjusting the LCD contrast.



Programmable function push-button.



Programmable function push-button.



ENTER push-button for activating or confirming a function.



UP navigation push-button for moving up in the menu or increasing a numerical value.



DOWN navigation push-button for moving down in the menu or decreasing a numerical value.



LEFT navigation push-button for moving backwards in a parallel menu or selecting a digit in a numerical value.



RIGHT navigation push-button for moving forwards in a parallel menu or selecting a digit in a numerical value.



Circuit Breaker ON push-button



Circuit Breaker OFF push-button



## LEDs

VAMP 57 IED has 12 LEDs on front. Two LEDs for function buttons (F1 & F2), two LEDs represents units general status (POWER and STATUS), and 8 user configurable LEDs (A - H). When the IED is powered the “ON” LED will lit as green. During normal use “Service” LED is not active, it activates only when error occurs or the IED is not operating correctly. Should this happen contact your local representative for further guidance. The Service LED and SF contact are assigned to work together. Manufacturer recommends that SF output is hardwired into the substation's automation system for alarm purposes.





LED can lit either green or red. The LEDs on the local HMI can be configured in VAMPSET. To customise the LED texts on the local HMI, the texts can be written on a template and then printed on a transparency. The transparencies can be placed to the pockets beside the LEDs.

LED indicator	Meaning	Measure/ Remarks
Power LED lit	The auxiliary power has been switched on	Normal operation state
Status LED lit	Internal fault, operates in parallel with the self supervision output relay	The relay attempts to reboot [REBOOT]. If the error LED remains lit, call for maintenance.  The Service LED and SF contact are assigned to work together. Manufacturer recommends that SF output is hardwired into the substation's automation system for alarm purposes.
A- H LED lit	Application-related status indicators.	Configurable
F1 / F2 LED lit	Corresponding function key pressed / activated	Depending of function programmed to F1 / F2

### Enter password

1. On the local HMI, press  and .
2. Enter the four-digit password and press .

### Adjusting LCD contrast (while correct password is enabled)

1. Press  and adjust the contrast.
  - To increase the contrast, press .
  - To decrease the contrast, press .
2. To return to the main menu, press .









**Release all latches (while correct password is enabled)**

1. Press 
  - To release the latches, press .
  - To release, choose "Release" parameter and press .



**Control object (while password and selective control is enabled)**

When selective control is enabled, control operation needs confirmation (select-execute)

1. Press  to close object.
  - Press  again to confirm.
  - Press  to cancel.
2. Press  to open object.
  - Press  again to confirm.
  - Press  to cancel.

**Control object (while password and direct control is enabled)**

When direct control is enabled, control operation is done without confirmation

1. Press  to close object.
2. Press  to open object.

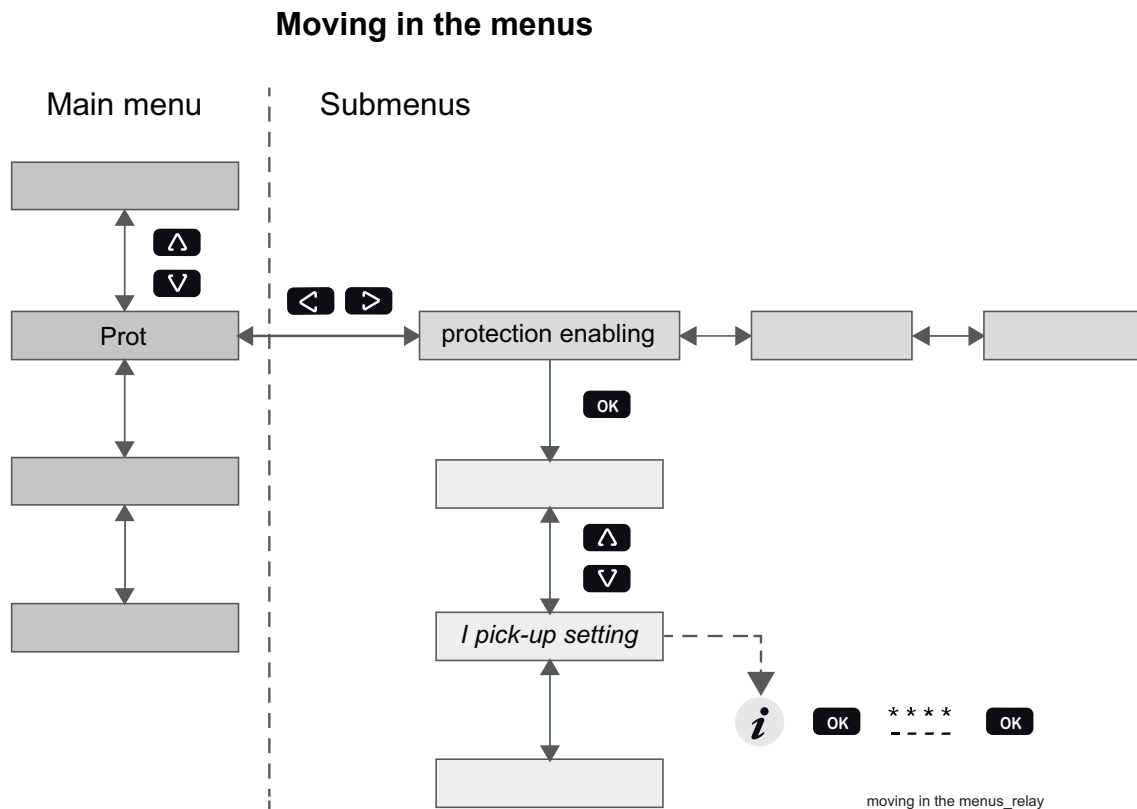

Figure 7.2: Moving in menus using local HMI

- To move in the main menu, press or .
- To move in submenus, press or .
- To enter a submenu, press and use or for moving down or up in the menu.
- To edit a parameter value, press and . Key in four-digit password and press .
- To go back to the previous menu, press .
- To go back to the first menu item in the main menu, press for at least three seconds.

**NOTE:** To enter the parameter edit mode, key in the password. When the value is in edit mode, its background is dark.

# 8 VAMPSET

## 8.1 VAMPSET setting and configuration tool

VAMPSET is a software tool for setting and configuring the VAMP IEDs. VAMPSET has a graphical interface, and the created documents can be saved and printed out for later use.

To use VAMPSET, you need

- PC with Windows XP (or newer) operating system installed
- VX052 or equivalent USB cable for connecting the IED to the PC (USB-cable provided by VAMP is recommended)
- Experience in using the Windows operating system

**NOTE:** Download the latest VAMPSET version at [m.vamp.fi](http://m.vamp.fi).

### 8.1.1 Folder view

In VAMPSET version 2.2.136, a feature called "Folder view" was introduced.

The idea of folder view is to make it easier for the user to work with relay functions inside VAMPSET. When folder view is enabled, VAMPSET gathers similar functions together and places them appropriately under seven different folders (GENERAL, MEASUREMENTS, INPUTS/OUTPUTS, MATRIX, LOGS and COMMUNICATION). The contents (functions) of the folders depend on the relay type and currently selected application mode.

Folder view can be enabled in VAMPSET via Program Settings dialog (Settings -> Program Settings), see Figure 8.1.

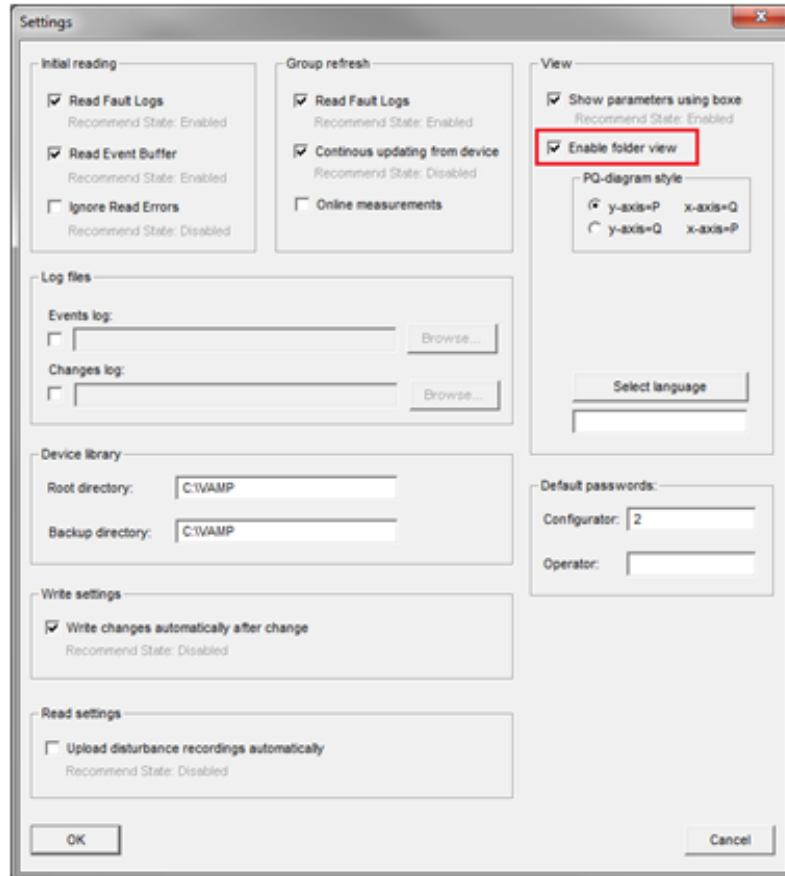

Figure 8.1: Enable folder view setting in Program Settings dialog

**NOTE:** It is possible to enable/ disable the folder view only when VAMPSET is disconnected from the relay and there is no configuration file opened.

When folder view is enabled, folder buttons become visible in VAMPSET, see Figure 8.2. Currently selected folder appears in bold.



Figure 8.2: Folder view buttons

## 8.2

## Configuring the system with VAMPSET

Before configuring the protection relay, you need

- PC with adequate user rights
- VAMPSET setting and configuration tool downloaded to the PC
- USB cable (VX052) for connecting the IED with the PC

## 8.2.1 Setting up the communication

- Connect the USB cable between the PC and the local port of the IED.

### Defining the PC serial port settings

**NOTE:** Ensure that the communication port setting on the PC corresponds to the IED setting.

1. Open the **Device Manager** on the PC and check the USB Serial Port number (COM) for the IED.
2. Open the VAMPSET setting and configuration tool on the PC.
3. On the VAMPSET **Settings** menu, select **Communication Settings**.
4. Select the correct port under the **Port** area and click **Apply**.

### Defining the VAMPSET communication settings

1. On the local HMI, go to the **CONF/ DEVICE SETUP** menu and check the local port bit rate.
2. On the VAMPSET **Settings** menu, select **Communication Settings**.
3. Under the **Local** area, select the corresponding speed (bps) from the drop-down list and click **Apply**.
4. In VAMPSET **Settings** menu, select **Program Settings**.

**NOTE:** If faster operation is needed, change the speed to 187500 bps both in VAMPSET and in the IED.

### Connecting the IED

1. On the VAMPSET **Communication** menu, select **Connect Device**.
2. Enter the password and click **Apply**. VAMPSET connects to the device.

**NOTE:** The default password for the configurator is 2.

## 8.2.2 Writing the settings to the IED

- In the VAMPSET **Communication** menu, select **Write All Settings To Device** to download the configuration to the IED.

**NOTE:** To save the IED configuration information for later use, also save the VAMPSET document file on the PC.

### 8.2.3 Saving the VAMPSET document file

Save the IED configuration information to the PC. The document file is helpful for instance if you need help in troubleshooting.

1. Connect the IED to the PC with an USB cable.
2. Open the VAMPSET tool on the PC.
3. On the **Communication** menu, select **Connect device**.
4. Enter the configurator password. The IED configuration opens.
5. On the **File** menu, click **Save as**.
6. Type a descriptive file name, select the location for the file and click **Save**.

**NOTE:** By default, the configuration file is saved in the VAMPSET folder.

# 9 Relay features

**Table 9.1: List of protection functions**

IEEE/ANSI code	IEC symbol	Function name
25	$\Delta f, \Delta U, \Delta \varphi$	Synchrocheck
27	$U<, U<<, U<<<$	Undervoltage protection
32	$P<, P<<$	Reverse power protection
37	$I<$	Undercurrent protection
46	$I_2 / I_1 >$	Current unbalance protection in feeder mode
46	$I_2 >$	Current unbalance protection in motor mode *
47	$I_2 >>$	Phase reversal / incorrect phase sequence protection *
48	$I_{ST} >$	Stall protection *
49	$T >$	Thermal overload protection
50/51	$I >, I >>, I >>>$	Overcurrent protection
50BF	CBFP	Circuit-breaker failure protection
50N/51N	$I_0 >, I_0 >>, I_0 >>>, I_0 >>>>, I_0 >>>>>$	Earth fault protection
59	$U >, U >>, U >>>$	Overvoltage protection
59N	$U_0 >, U_0 >>, U_0 >>>$	Zero sequence voltage protection
66	$N >$	Frequent start protection *
67	$I_\varphi >, I_\varphi >>, I_\varphi >>>, I_\varphi >>>>$	Directional overcurrent protection
67N	$I_{0\varphi} >, I_{0\varphi} >>, I_{0\varphi} >>>$	Directional earth-fault, low-set stage, sensitive, definite or inverse time (can be used as non directional)
67NI	$I_{0INT} >$	Intermittent transient earth fault protection
68F2	$I_{f2} >$	Magnetising inrush
68F5	$I_{f5} >$	Transformer overexcitation
81H/81L	$f ><, f >><<$	Overfrequency and underfrequency protection
81L	$f <, f <<$	Underfrequency protection
81R	$df/dt$	Rate of change of frequency (ROCOF) protection
99	Prg1 – 8	Programmable stages

\* Only available when application mode is motor protection

Further the relay includes a disturbance recorder.

The relay communicates with other systems using common protocols, such as the Modbus RTU, ModbusTCP, IEC 60870-5-103, IEC 60870-5-101, IEC 61850, SPA bus, Ethernet / IP and DNP 3.0.

## 9.1 User interface

The relay can be controlled in three ways:

- Locally with the push-buttons on the relay front panel
- Locally using a PC connected to the USB port on the front
- Via remote control over the optional remote control port on the relay rear panel.



# 10 Connections

## 10.1 Rear panel

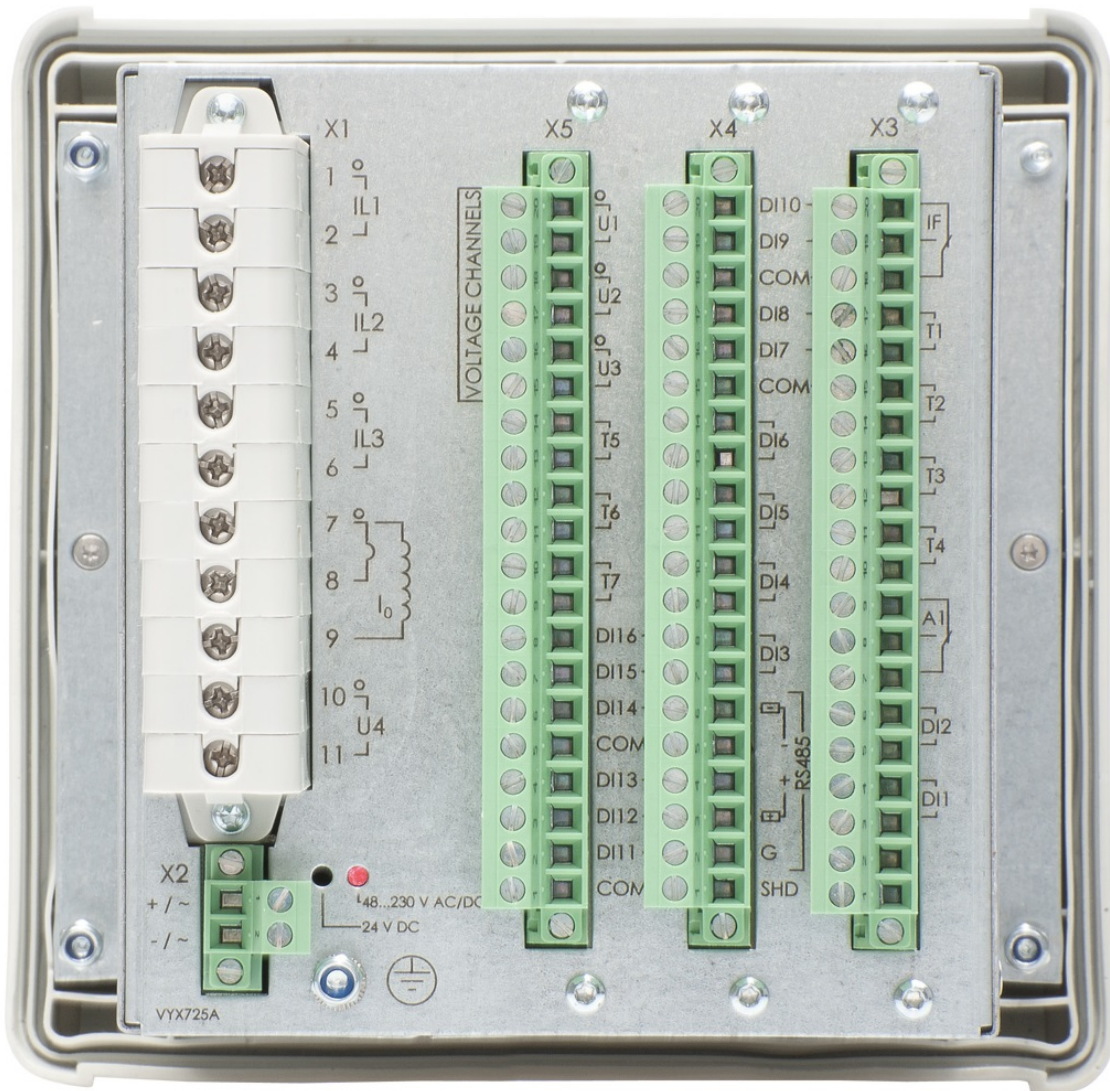

Figure 10.1: Connections on the rear panel of the V57F-3AAA1BBA with screw clamp connectors

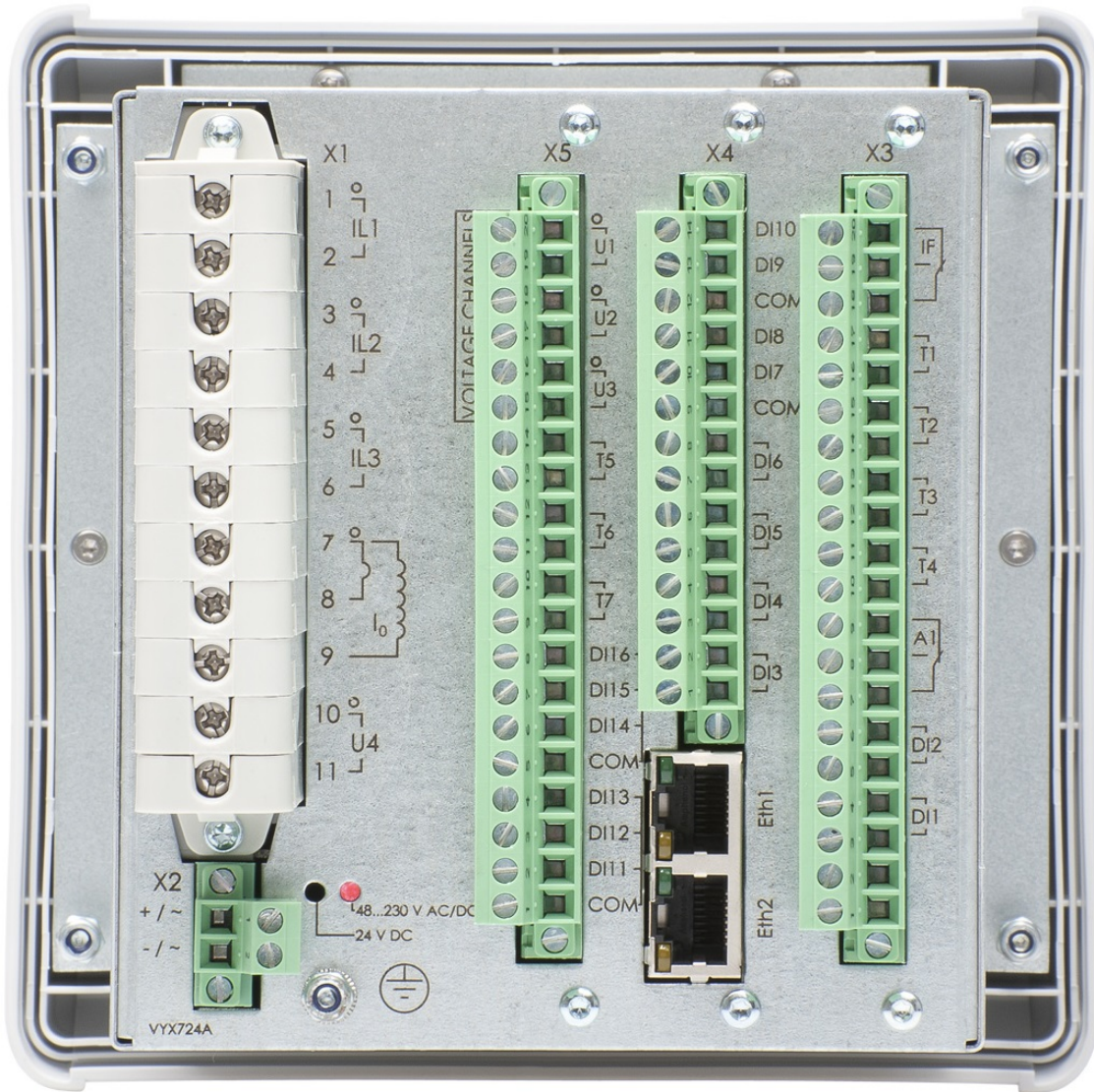

Figure 10.2: Connections on the rear panel of the V57F-3AAA1BCA with screw clamp connector

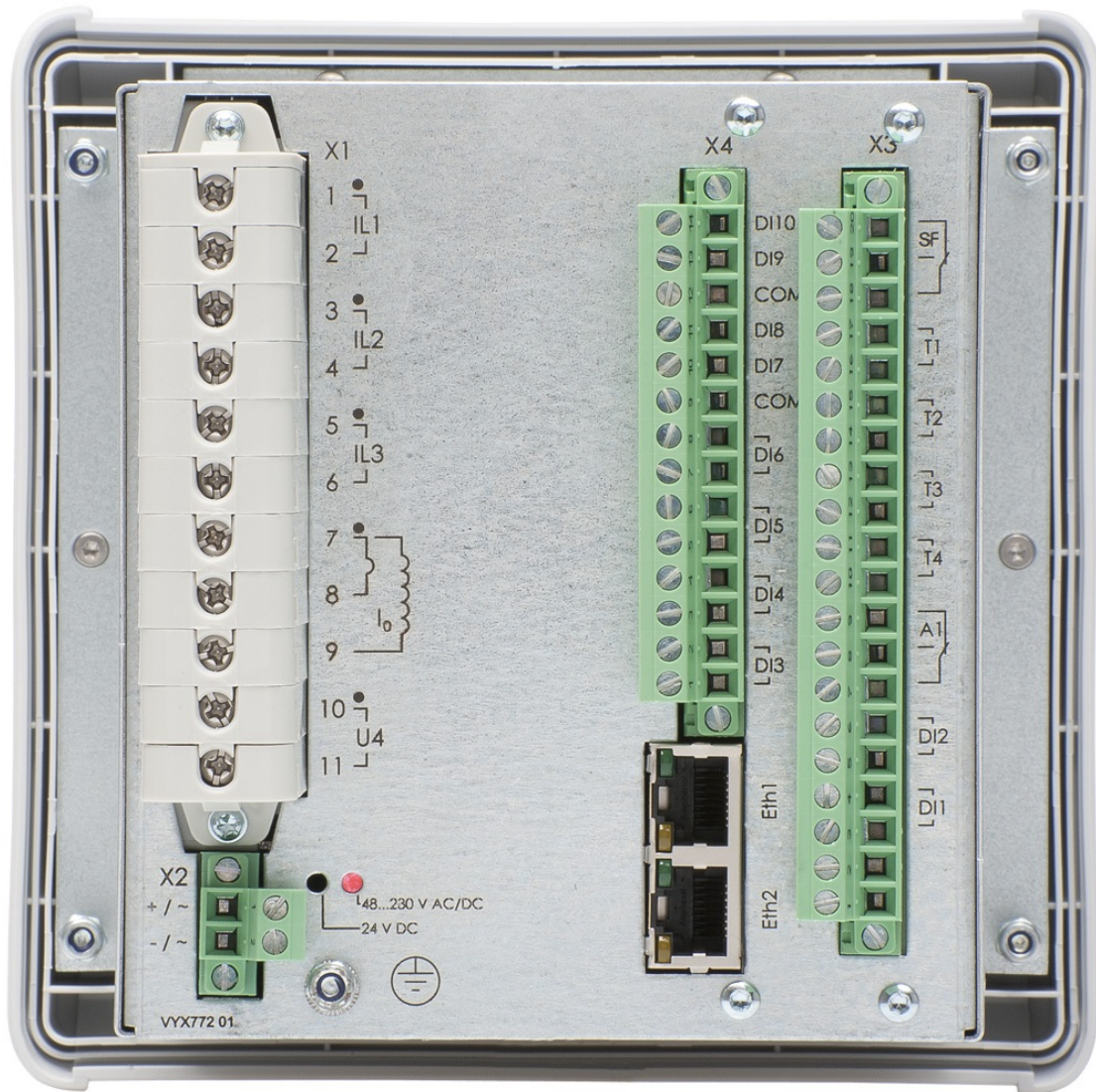

Figure 10.3: Connections on the rear panel of the V57F-3AAA1ACA with screw clamp connector. This model does not have X5 module hence the device has 3 x IL, 1xIo, 1xU, 10xDI, 4xDO (trip), 1 x Alarm, 1 x SF only.

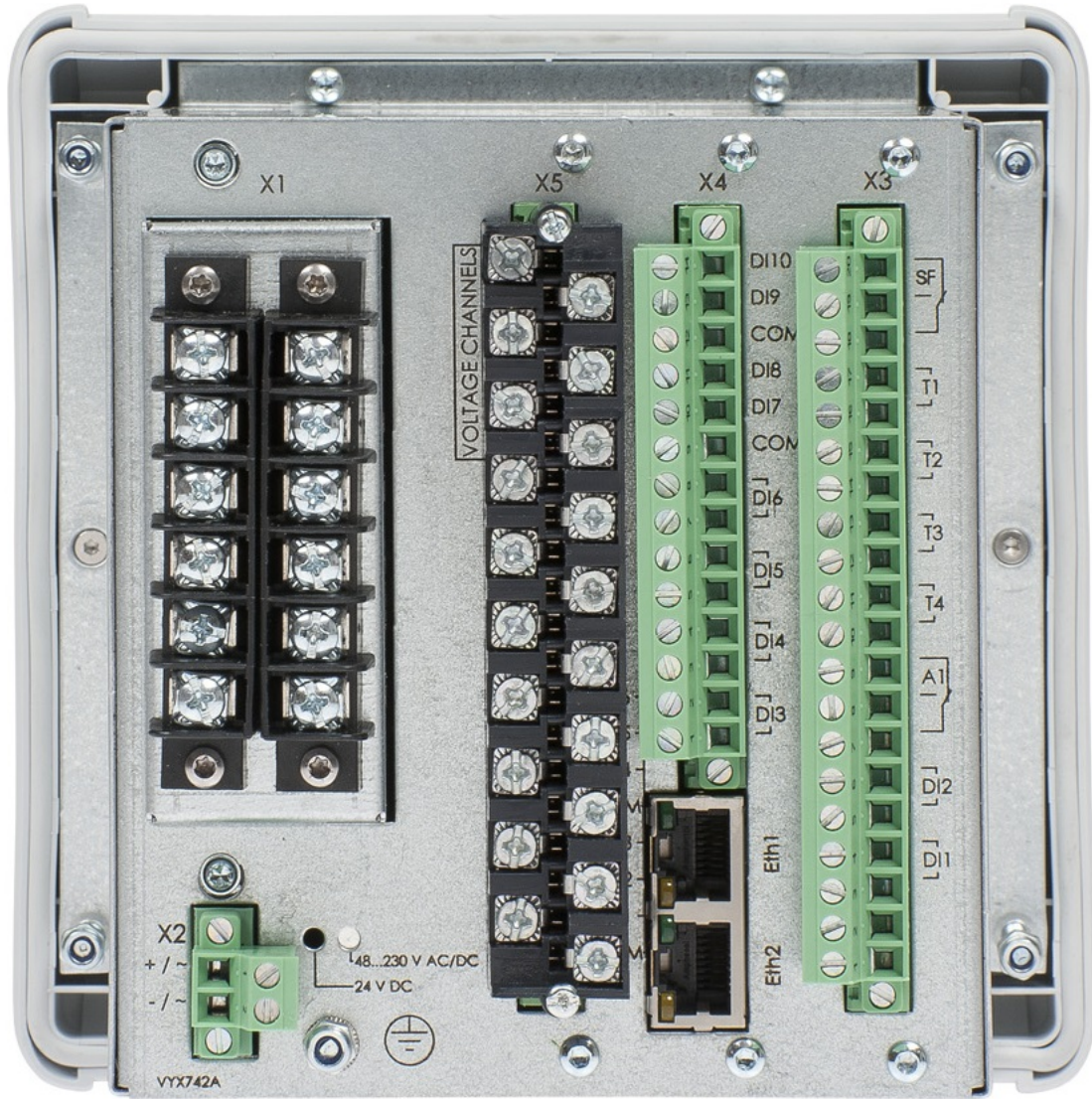

Figure 10.4: Connections on the rear panel of the V57F-4AAA1BCA with ring-lug connector

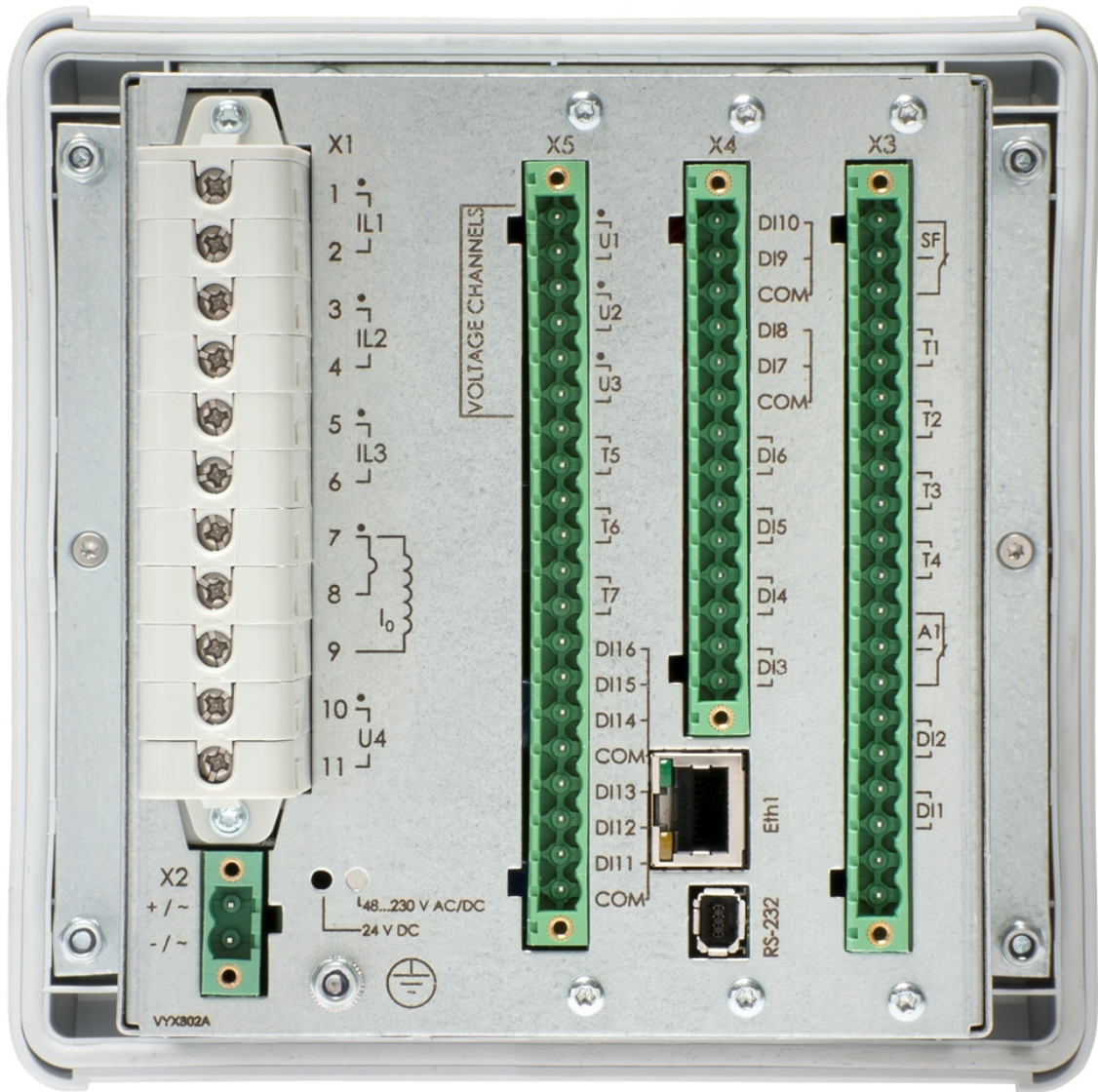

Figure 10.5: Connections on the rear panel of the V57F-3AAA1BEA with screw clamp connector containing RS-232 interface for serial protocols, external I/O communication, IRIG-B as well RJ-45 for Ethernet communication protocols.

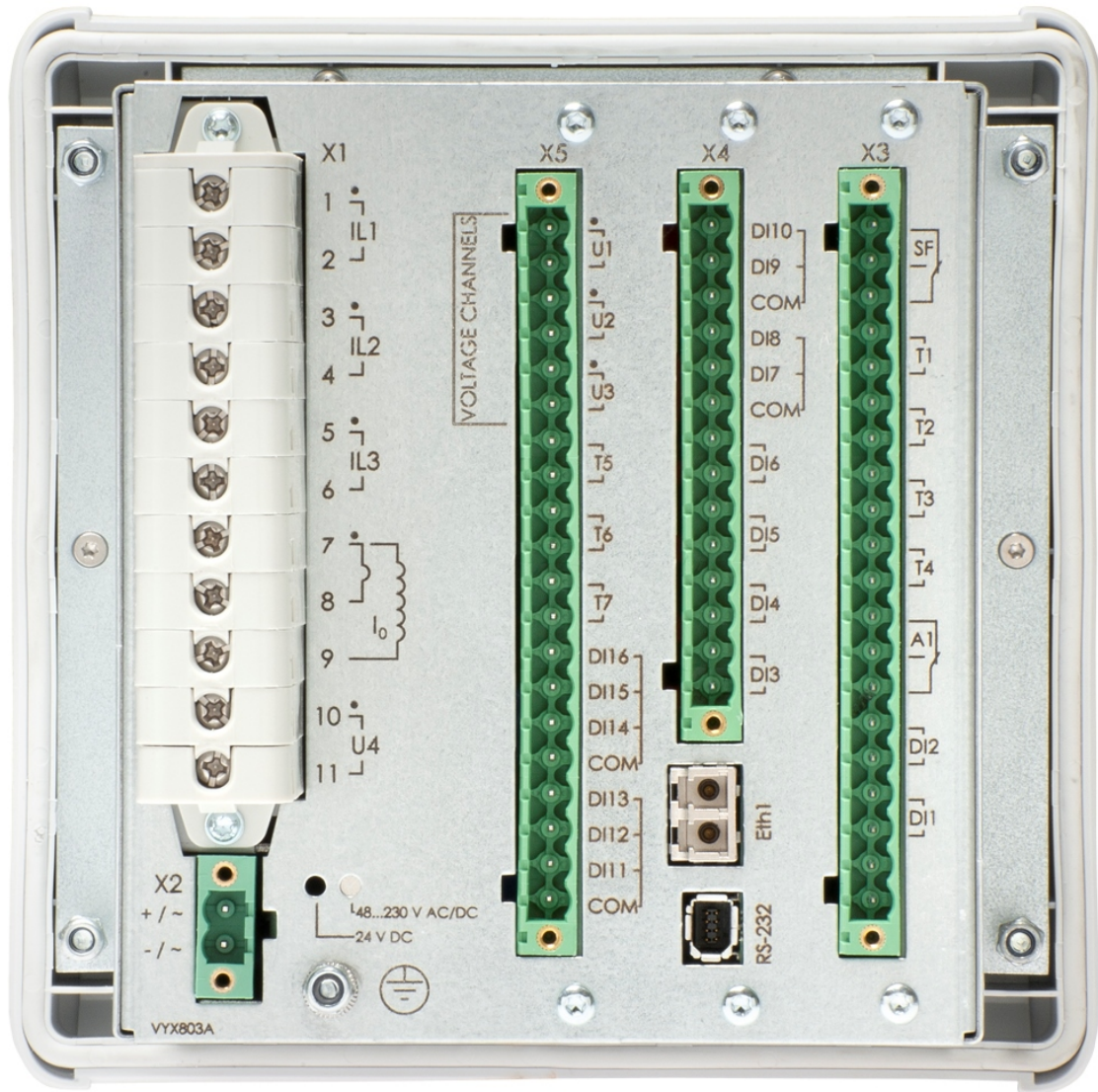

Figure 10.6: Connections on the rear panel of the V57F-3AAA1BFA with screw clamp connector containing RS-232 interface for serial protocols, external I/O communication, IRIG-B as well LC for Ethernet communication protocols.

**Table 10.1: Voltage measurement modes**

Terminal	X5						X1	
	20	19	18	17	16	15	10	11
Voltage channel	U1		U2		U3		U4	
<b>Mode / Used voltage</b>								
3LN	UL1		UL2		UL3		-	UL3
3LN+U <sub>0</sub>							U <sub>0</sub>	
3LN+LL <sub>y</sub>					UL3			
3LN+LN <sub>y</sub>								
2LL+U <sub>0</sub>	U12		U23		U <sub>0</sub>		-	U <sub>0</sub>
2LL+U <sub>0</sub> +LL <sub>y</sub>							U <sub>0</sub>	
2LL+U <sub>0</sub> +LN <sub>y</sub>					U <sub>0</sub>			
LL+U <sub>0</sub> +LL <sub>y</sub> +LL <sub>z</sub>						U12 <sub>y</sub>	U12 <sub>z</sub>	
LN+U <sub>0</sub> +LN <sub>y</sub> +LN <sub>z</sub>	UL1	UL1 <sub>y</sub>	UL1 <sub>z</sub>					

**Terminal X1 (screw clamp connector)**



No	Symbol	Description
1	IL1(S1)	Phase current L1 (S1)
2	IL1(S2)	Phase current L1 (S2)
3	IL2(S1)	Phase current L2 (S1)
4	IL2(S2)	Phase current L2 (S2)
5	IL3(S1)	Phase current L3 (S1)
6	IL3(S2)	Phase current L3 (S2)
7	Io1	Residual current Io1 common for 1 A and 5 A (S1)
8	Io1/5A	Residual current Io1 5A (S2)
9	Io1/1A	Residual current Io1 1A (S2)
10	U4	U <sub>0</sub> /ULN/ULL (da/a/a)
11	U4	U <sub>0</sub> /ULN/ULL (dn/n/b)

**NOTE:** Terminal X1 can be ring-lug type, too.

**Terminal X1 (ring-lug connector)**

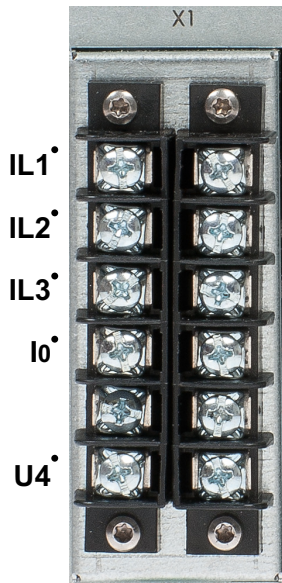

Symbol	Description
IL1•	Phase current L1 (S1)
IL1	Phase current L1 (S2)
IL2•	Phase current L2 (S1)
IL2	Phase current L2 (S2)
IL3•	Phase current L3 (S1)
IL3	Phase current L3 (S2)
Io•	Residual current Io1 common for 1 A and 5 A (S1)
Io5A	Residual current Io1 5A (S2)
Io1A	Residual current Io1 1A (S2)
U4•	Uo/U <sub>LN</sub> /U <sub>LL</sub> (da/a/a)
U4	Uo/U <sub>LN</sub> /U <sub>LL</sub> (dn/n/b)



### Terminal X2

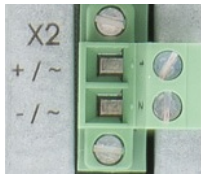

No	Symbol	Description
1	$U_{AUX}$	Auxiliary voltage
2	$U_{AUX}$	Auxiliary voltage

### Terminal X3

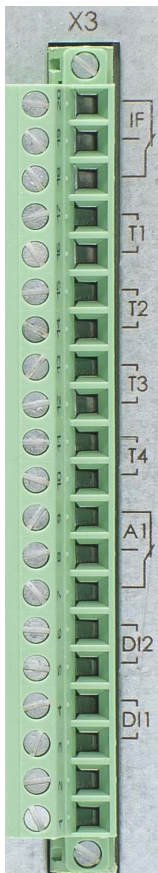

No	Symbol	Description
20	SF NO	Self-diagnostic relay, normal close
19	SF NC	Self-diagnostic relay, normal open
18	SF COM	Self-diagnostic relay, common terminal
17	T1	Trip relay 1
16	T1	Trip relay 1
15	T2	Trip relay 2
14	T2	Trip relay 2
13	T3	Trip relay 3
12	T3	Trip relay 3
11	T4	Trip relay 4
10	T4	Trip relay 4
9	A1 NC	Alarm relay 1, normal closed terminal
8	A1 NO	Alarm relay 1, normal open terminal
7	A1 COM	Alarm relay 1, common terminal
6	DI2 +	Digital input 2
5	DI2 -	Digital input 2
4	DI1 +	Digital input 1
3	DI1 -	Digital input 1
2	-	No connection
1	-	No connection

**NOTE:** Digital inputs are polarity free.

**Terminal X5 (screw clamp connector)**

No	Symbol	Description
20	U1	ULN/ULL (a/a)
19	U1	ULN/ULL (n/b)
18	U2	ULN/ULL (a/a)
17	U2	ULN/ULL (n/b)
16	U3	Uo/ULN/ULL (da/a/a)
15	U3	Uo/ULN/ULL (dn/n/b)
14	T5	Trip relay 5
13	T5	Trip relay 5
12	T6	Trip relay 6
11	T6	Trip relay 6
10	T7	Trip relay 7
9	T7	Trip relay 7
8	DI16	Digital input 16
7	DI15	Digital input 15
6	DI14	Digital input 14
5	COM	Common potential of digital inputs 14 – 16
4	DI13	Digital input 13
3	DI12	Digital input 12
2	DI11	Digital input 11
1	COM	Common potential of digital inputs 11 – 13

**NOTE:** Terminal X5 can be ring-lug type, too.

When the option A in the slot of "Voltage measurements + I/O, X5" is selected, Terminal X5's inputs and outputs are not available.

**Terminal X5 (ring-lug connector)**

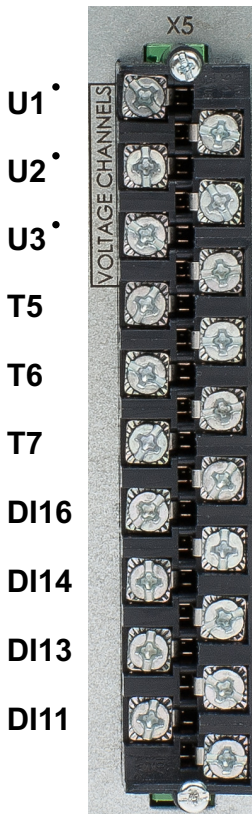

Symbol	Description
U1•	ULN/ULL (a/a)
U1	ULN/ULL (n/b)
U2•	ULN/ULL (a/a)
U2	ULN/ULL (n/b)
U3•	Uo/ULN/ULL (da/a/a)
U3	Uo/ULN/ULL (dn/n/b)
T5	Trip relay 5
T6	Trip relay 5
T7	Trip relay 6
T6	Trip relay 6
T7	Trip relay 7
T7	Trip relay 7
DI16	Digital input 16
DI15	Digital input 15
DI14	Digital input 14
DI13	Digital input 13
DI12	Digital input 12
DI11	Digital input 11
COM	Common potential of digital inputs 14 – 16
COM	Common potential of digital inputs 11 – 13

**NOTE:** When the option A in the slot of "Voltage measurements + I/O, X5" is selected, Terminal X5's inputs and outputs are not available.

**Terminal X4 (I/O Communication: model V57-3AAA1BBA)**

2 pair RS-485 with internal terminating resistor selection

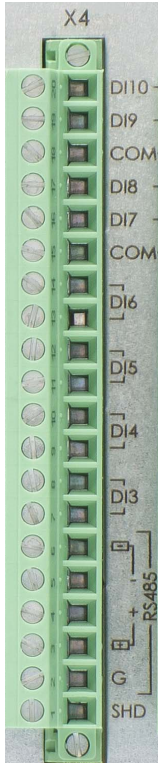

No	Symbol	Description
20	DI10	Digital input 10
19	DI9	Digital input 9
18	COM	Common potential of digital inputs 9 – 10
17	DI8	Digital input 8
16	DI7	Digital input 7
15	COM	Common potential of digital inputs 7 – 8
14	DI6	Digital input 6
13	DI6	Digital input 6
12	DI5	Digital input 5
11	DI5	Digital input 5
10	DI4	Digital input 4
9	DI4	Digital input 4
8	DI3	Digital input 3
7	DI3	Digital input 3
6*	RS-485 term	RS-485 interface termination resistor for “-” connection
5*	RS-485 -	RS-485 interface “-” connection
4*	RS-485 +	RS-485 interface “+” connection
3*	RS-485 term	RS-485 interface termination resistor for “+” connection
2	RS-485 G	RS-485 interface ground terminal
1	RS-485 SHD	RS-485 interface cable shield connection

**NOTE:** \* interconnect 3&4 and 5&6 when termination is needed.

### Terminal X4 (I/O Communication model: model V57-3AAA1BCA)

2 Ethernet RJ-45 connectors for daisy-chain or loop configuration using RSTP protocol



No	Symbol	Description
14	DI10	Digital input 10
13	DI9	Digital input 9
12	COM	Common potential of digital inputs 9 – 10
11	DI8	Digital input 8
10	DI7	Digital input 7
9	COM	Common potential of digital inputs 7 – 8
8	DI6	Digital input 6
7	DI6	Digital input 6
6	DI5	Digital input 5
5	DI5	Digital input 5
4	DI4	Digital input 4
3	DI4	Digital input 4
2	DI3	Digital input 3
1	DI3	Digital input 3

### Terminal X4 (I/O Communication model: model V57-3AAA1BDA)

2 Ethernet fibre interface for daisy-chain or loop configuration using RSTP protocol



No	Symbol	Description
14	DI10	Digital input 10
13	DI9	Digital input 9
12	COM	Common potential of digital inputs 9 – 10
11	DI8	Digital input 8
10	DI7	Digital input 7
9	COM	Common potential of digital inputs 7 – 8
8	DI6	Digital input 6
7	DI6	Digital input 6
6	DI5	Digital input 5
5	DI5	Digital input 5
4	DI4	Digital input 4
3	DI4	Digital input 4
2	DI3	Digital input 3
1	DI3	Digital input 3

**Terminal X4 (I/O Communication model: model V57F-3AAA1BEA)**

Ethernet RJ-45 and RS-232 serial interfaces

Cable VX082, VX083 or VX084 is needed for connecting external option modules to RS-232 connector of the VAMP 57.

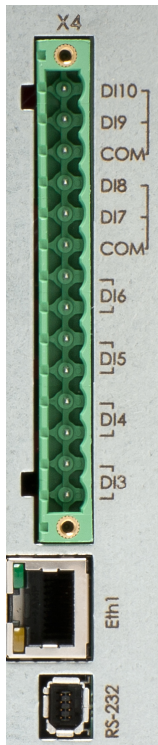

No	Symbol	Description
14	DI10	Digital input 10
13	DI9	Digital input 9
12	COM	Common potential of digital inputs 9 – 10
11	DI8	Digital input 8
10	DI7	Digital input 7
9	COM	Common potential of digital inputs 7 – 8
8	DI6	Digital input 6
7	DI6	Digital input 6
6	DI5	Digital input 5
5	DI5	Digital input 5
4	DI4	Digital input 4
3	DI4	Digital input 4
2	DI3	Digital input 3
1	DI3	Digital input 3

**Terminal X4 (I/O Communication model: model V57F-3AAA1BFA)**

Ethernet fibre and RS-232 serial interfaces

Cable VX082, VX083 or VX084 is needed for connecting external option modules to RS-232 connector of the VAMP 57.

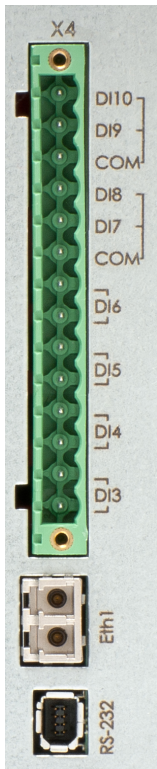

No	Symbol	Description
14	DI10	Digital input 10
13	DI9	Digital input 9
12	COM	Common potential of digital inputs 9 – 10
11	DI8	Digital input 8
10	DI7	Digital input 7
9	COM	Common potential of digital inputs 7 – 8
8	DI6	Digital input 6
7	DI6	Digital input 6
6	DI5	Digital input 5
5	DI5	Digital input 5
4	DI4	Digital input 4
3	DI4	Digital input 4
2	DI3	Digital input 3
1	DI3	Digital input 3



## 10.2 Local port (Front panel)

The relay has a USB-connector in the front panel

### Protocol for the USB port

The front panel USB port is always using the command line protocol for VAMPSET.

The protocol is an ASCII character protocol called "GetSet". The speed of the interface is defined in CONF/DEVICE SETUP menu from the local HMI. The default settings for the relay are 38400/8N1.

Connecting a cable between the PC and the relay will create a virtual com-port. The default settings for the relay are 38400/8N1. The communication parameter display on the local display will show the active parameter values for the local port.

### Physical interface

The physical interface of this port is USB.

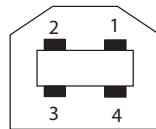

Figure 10.7: Pin numbering of the front panel USB type B connector

Pin	Signal name
1	VBUS
2	D-
3	D+
4	GND
Shell	Shield

It is possible to change the bit rate of front USB port. This setting is visible only on local display of the IED. Bit rate can be set between 1200 - 187500. This changes the bit rate of the IED, Vampset bit rate has to be set separately. If bit rate in setting tool is incorrect it takes longer time to establish the communication.

**NOTE:** Use same bit rate in the IED and VAMPSET -setting tool.

# 11

# Block diagram

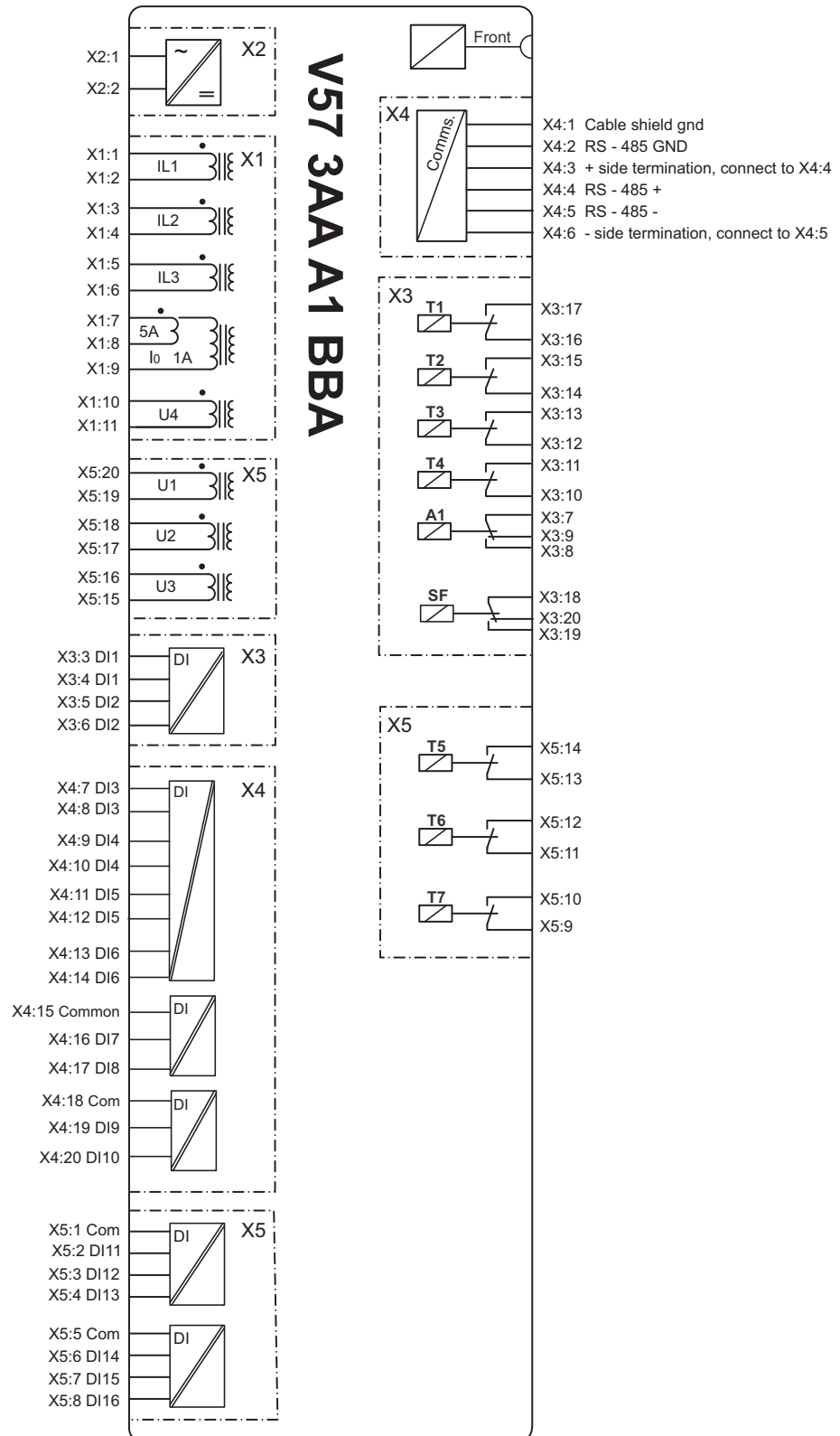

Figure 11.1: VAMP 57 3AA A1BBA block diagram

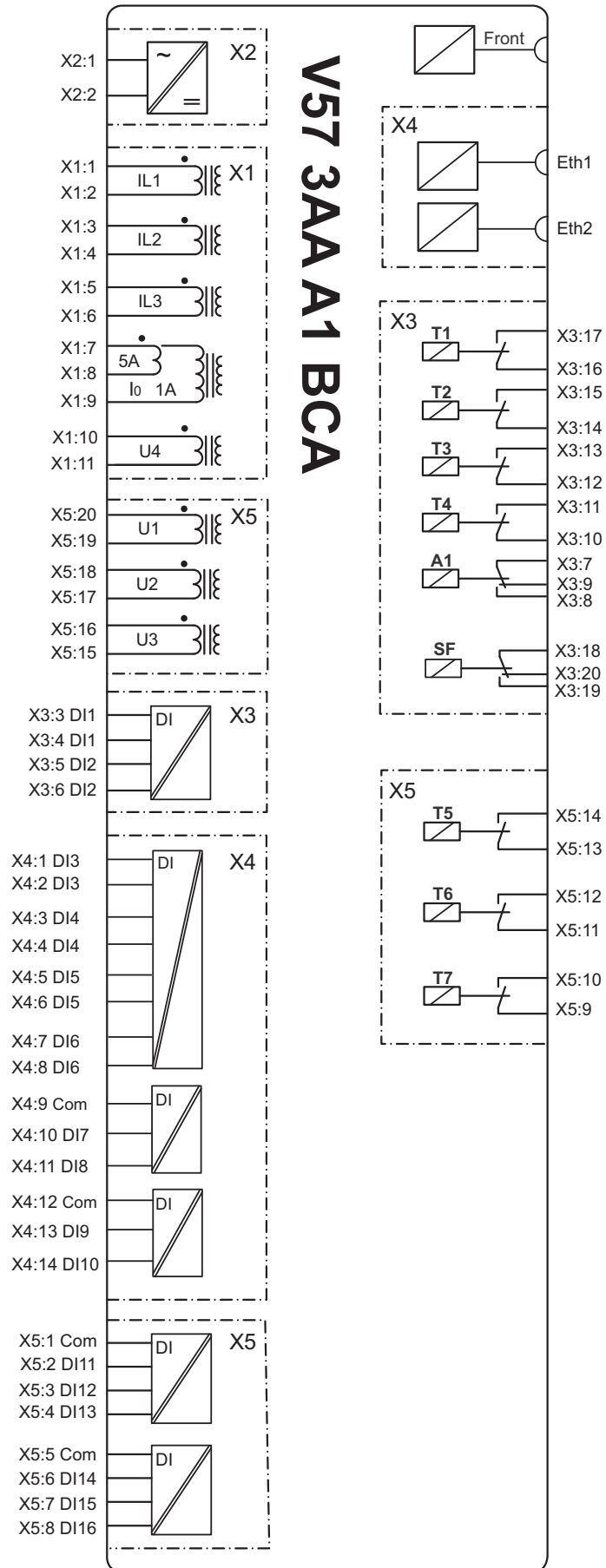
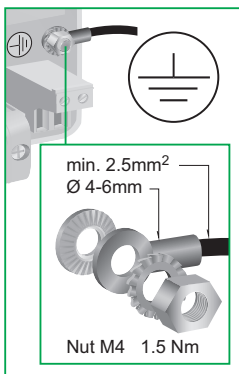
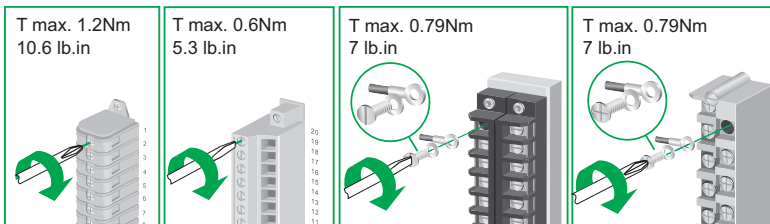
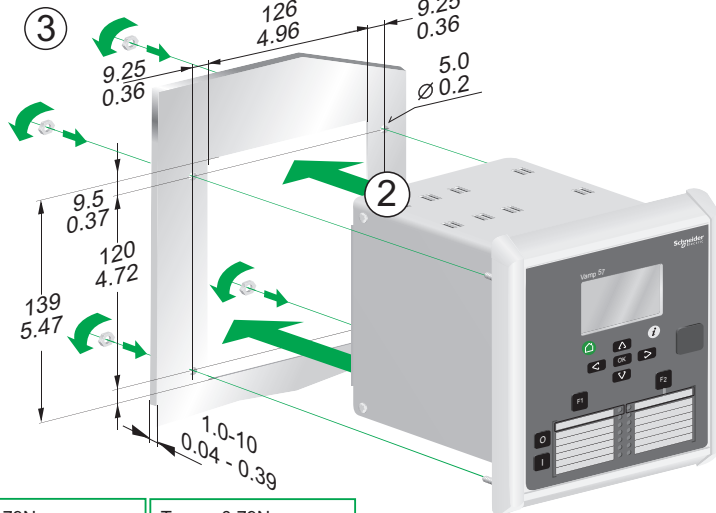
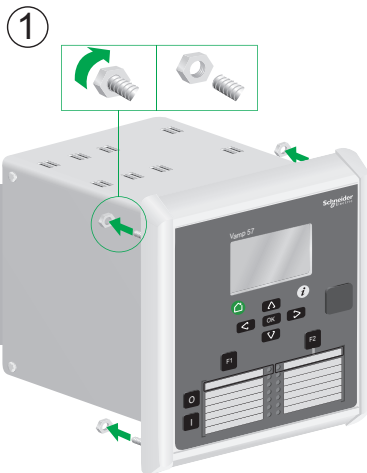
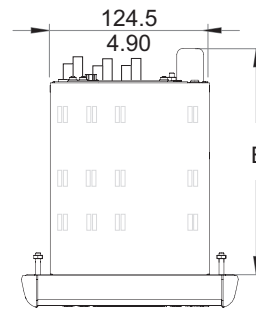
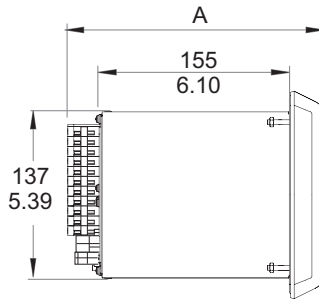
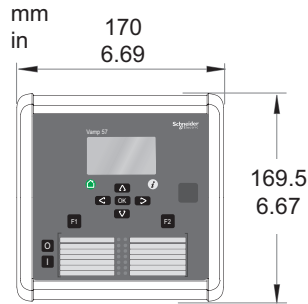

Figure 11.2: VAMP 57 3AA A1 BCA block diagram

# 12 Mounting

## PANEL MOUNTING VAMP 57

	A	B
V57F-3	205 mm / 8.07"	182 mm / 7.17"
V57F-4	206 mm / 8.11"	183 mm / 7.20"



---

# 13 Related documents

Document	Identification*)
VAMP 57 user manual	V57_EN_M_XXXX
VAMPSET Setting and Configuration Tool User Manual	VVAMPSET_EN_M_XXXX

\*) *XXXX = revision number*

Download the latest software and manual at [m.vamp.fi](http://m.vamp.fi).







Customer Care Centre

**Schneider Electric**

35 rue Joseph Monier  
92506 Rueil-Malmaison  
FRANCE

Phone: +33 (0) 1 41 29 70 00

Fax: +33 (0) 1 41 29 71 00

Publication version: V57/en QS/A007

Publishing:

10/2016

2016 Schneider Electric. All rights reserved.