

Stream Sign Of Quality



MOTOR
ALTERNATOR
2006



ISO9001

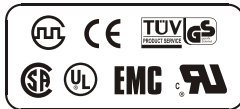

TIANJIN ELECMOTOR CO., LTD.

NO.78 SHIYIJING ROAD, HE DONG DISTRICT, TIANJIN 300171 CHINA
TEL: 0086 22 84180992; 84180993
FAX: 0086 22 84180998
http://www.streampumps.com
Email: sales@streampumps.com

Stream[®]
Sign of Quality

BRIEF Introduction

Over the years, *Stream* has specialized in designing, manufacturing, sourcing of different kinds of electric motors. Since 1997, *Stream* has established strategic, technological and commercial relationship with global companies from Europe, Asia and U.S. Today we have a range of motor to drive home appliances, Agriculture machinery, Industrial Machine, Civil Construction Machine etc. , from micro 6W up to High voltage industrial use 3000KW.

As *Stream* our goal is to provide the products with full scale services to our global customer, which could be measured by:

- The right quality of products
- Optimizing the total logistics costs
- Deliveries just in time
- Exchange of information concerning the products and technologies
- Securing a high degree of ethical and environmental consciousness.

Stream understand that to meet the challenge in the new millennium, the best is to align and continuously cooperate with its customers with qualified products, more competitive commercial conditions, more efficient service.

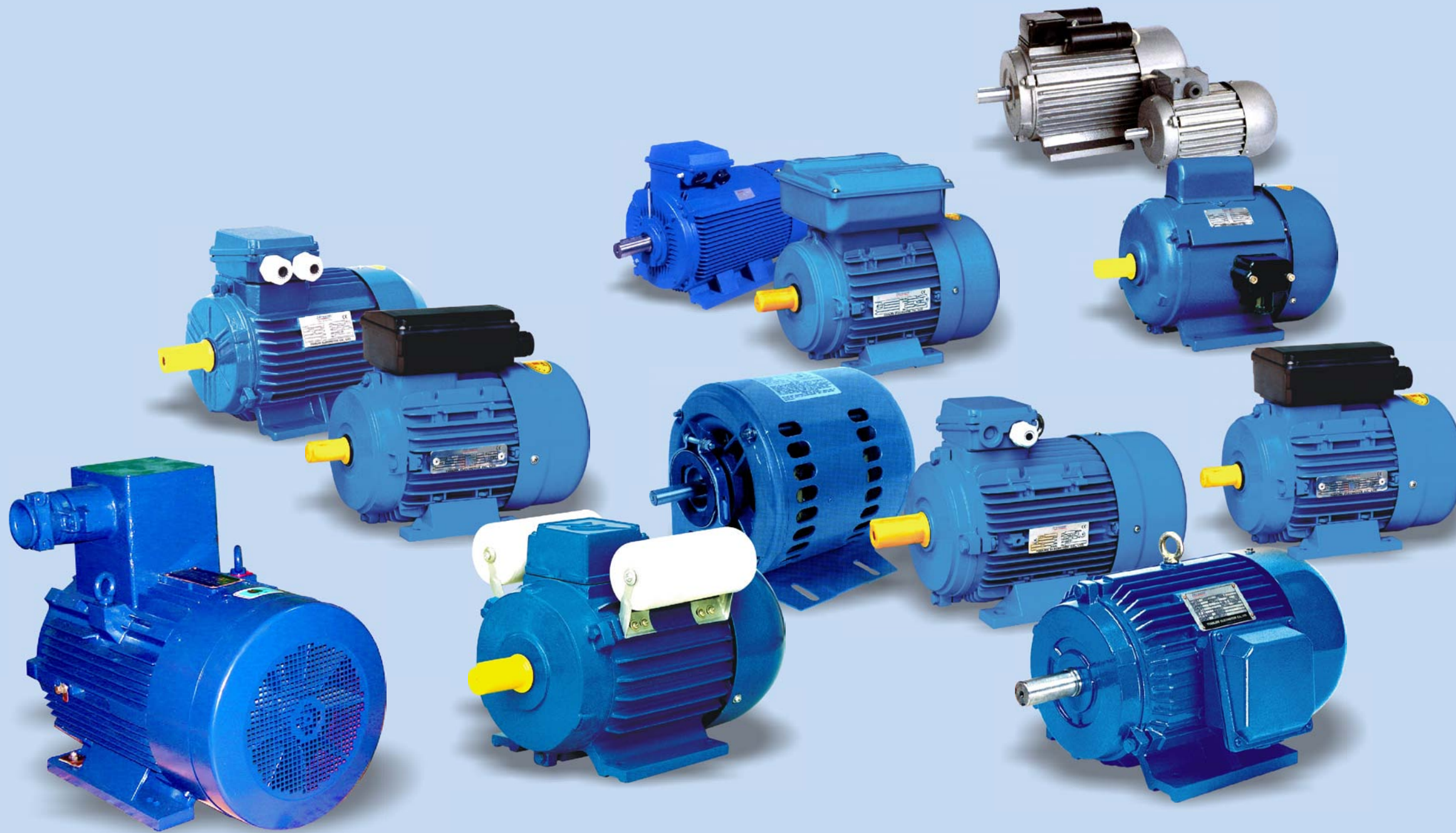

MS	Page 01
MC	Page 05
MY	Page 07
ML	Page 09
Y2	Page 11

Y	Page 14
YD	Page 17
YB	Page 19
YC	Page 20
YL	Page 21

JY	Page 23
YU	Page 24
CR	Page 24
YTF	Page 25

M/S

SERIES THREE-PHASE ASYNCHRONOUS MOTOR

ALUMINUM HOUSING

EFF2

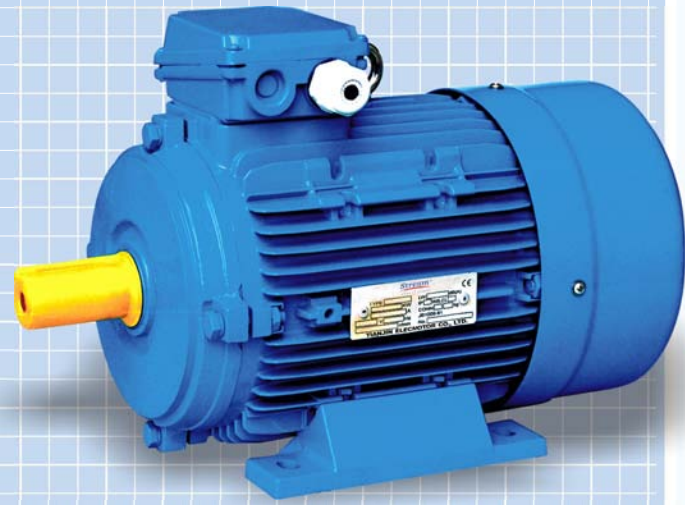

Conform to the IEC standard
Be made of selected quality materials, latest design in entirety.
Good performance, low noise, little vibration, and safety and reliable operation.
Nice appearance, light weight.
Be maintained very conveniently, simple construction.
Be used for general drive.
The Efficiency meet EFF2 standards.

MOTOR FEATURES

- Utilise IP54 enclosures, IP55 on request
- Multiple feet locations
- Aluminium frame, end shields and base
- High strength cable gland
- Shaft key and protector supplied
- Superior paint finish
- Motors made to heavy duty service factors
- Can be made with stainless steel shaft
- Motors made for continuous S1 duty
- Utilise Vacuum impregnated Class B insulation
- Class F insulation on request
- High performance and efficiency

CUSTOMER BENEFITS

- Water dust and vermin resistant
- Quiet operation
- Electricity saving
- Easy installation (bolt on feet or brackets as required)
- Corrosion resistant
- Dependable
- Superior life
- Reliable in country, city or factory environments

INSTALLATION DIMENSIONS

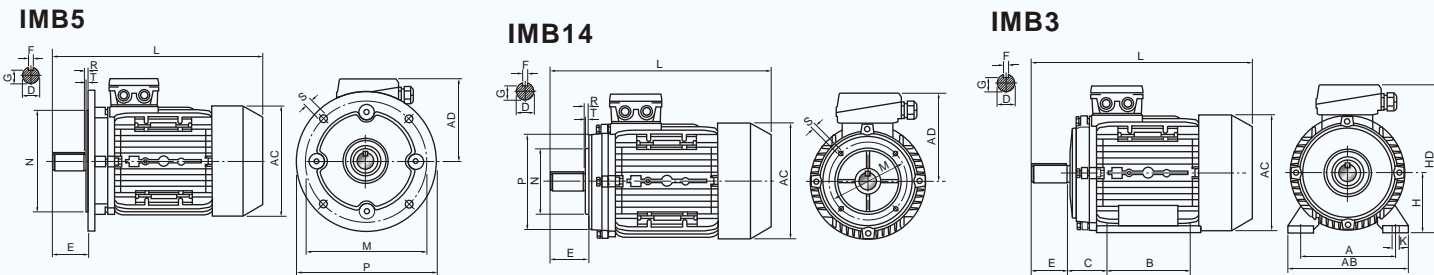

Frame Size	Mounting Dimensions (mm)																		Frame Dimensions (mm)							
	IMB3						IMB14						IMB5						AB	AC	AD	HD	L			
	A	B	C	D	E	F	G	H	K	M	N	P	R	S	T	M	N	P	R	S	T	AB	AC	AD	HD	L
56	90	71	36	9	20	3	7.2	56	5.8	65	50	80	0	M5	2.5	98	80	120	0	7	3.0	110	120	110	155	195
63	100	80	40	11	23	4	8.5	63	7	75	60	90	0	M5	2.5	115	95	140	0	10	3.0	130	130	115	165	230
71	112	90	45	14	30	5	11	71	7	85	70	105	0	M6	2.5	130	110	160	0	10	3.5	145	145	125	185	255
80	125	100	50	19	40	6	15.5	80	10	100	80	120	0	M6	3.0	165	130	200	0	12	3.5	160	165	135	215	295
90S	140	100	56	24	50	8	20	90	10	115	95	140	0	M8	3.0	165	130	200	0	12	3.5	180	185	145	235	335
90L	140	125	56	24	50	8	20	90	10	115	95	140	0	M8	3.0	165	130	200	0	12	3.5	180	185	145	235	360
100L	160	140	63	28	60	8	24	100	12	130	110	160	0	M8	3.5	215	180	250	0	15	4.0	205	215	170	255	380
112M	190	140	70	38	60	8	24	112	12	130	110	160	0	M8	3.5	215	180	250	0	15	4.0	245	240	180	285	400
132S	216	140	89	38	80	10	33	132	12	165	130	200	0	M10	4.0	265	230	300	0	15	4.0	280	275	195	325	475
132M	216	178	89	38	80	10	33	132	12	165	130	200	0	M10	4.0	265	230	300	0	15	4.0	280	275	195	325	515
160M	254	210	108	43	110	12	37	160	15	215	180	250	0	M12	4.0	300	250	350	0	15	5.0	320	330	255	420	615
160L	254	254	108	42	110	12	37	160	15	215	180	250	0	M12	4.0	300	250	350	0	15	5.0	320	330	255	420	670
180M	279	241	121	48	110	14	42.5	180	15	265	230	300	0	M15	4.0	300	250	350	0	19	5.0	355	380	280	455	700
180L	279	279	121	48	110	14	42.5	180	15	265	230	300	0	M15	4.0	300	250	350	0	19	5.0	355	380	280	455	740

TECHNICAL DATA (EFF2)

Model	Power (kW)	Voltage (V)	Current (A)	Speed (r/min)	Eff. (%)	Power factor	Locked rotor torque Rated torque	Locked rotor current Rated current	Max torque Rated torque
Synchronous Speed 3000r/min(2p)50Hz									
MS-802-2	1.1	220/380	4.24/2.45	2825	≥76.2	0.84	2.2	7.0	2.2
MS-90S-2	1.5	220/380	5.76/3.68	2840	≥78.5	0.85	2.2	7.0	2.2
MS-90L-2	2.2	220/380	8.26/4.85	2840	≥81.0	0.85	2.2	7.0	2.2
MS-100L-2	3.0	220/380	10.6/6.23	2880	≥82.6	0.87	2.2	7.0	2.2
MS-112M-2	4.0	380/660	7.8/4.5	2890	≥84.2	0.90	2.2	8.0	2.2
MS-132S1-2	5.5	380/660	10.5/6.1	2900	≥85.7	0.90	2.2	8.0	2.2
MS-132S2-2	7.5	380/660	14.4/8.4	2900	≥87.0	0.90	2.2	8.0	2.2
MS-160M1-2	11.0	380/660	19.6/11.5	2930	≥88.4	0.90	2.2	8.0	2.2
MS-160M2-2	15.0	380/660	26.5/15.6	2930	≥89.4	0.90	2.2	8.0	2.2
MS-160L-2	18.5	380/660	32.7/19.2	2930	≥90.0	0.90	2.2	8.0	2.2
MS-180M-2	22.0	380/660	39.1/23.1	2940	≥90.5	0.90	2.2	8.0	2.2
Synchronous Speed 1500r/min(4p)50Hz									
MS-90S-4	1.1	220/380	4.55/2.67	1400	≥76.2	0.75	2.2	6.0	2.2
MS-90L-4	1.5	220/380	6.05/3.55	1400	≥78.5	0.77	2.2	6.0	2.2
MS-100L1-4	2.2	220/380	8.3/4.8	1420	≥81.0	0.78	2.2	6.5	2.2
MS-100L2-4	3.0	220/380	11.2/6.5	1420	≥82.6	0.78	2.2	6.5	2.2
MS-112M-4	4.0	380/660	8.4/4.9	1440	≥84.2	0.81	2.2	7.0	2.2
MS-132S-4	5.5	380/660	11.5/6.7	1440	≥85.7	0.82	2.2	7.0	2.2
MS-132M-4	7.5	380/660	14.6/8.6	1440	≥87.0	0.82	2.2	7.0	2.2
MS-160M-4	11.0	380/660	20.8/12.2	1460	≥88.4	0.83	2.2	7.0	2.2
MS-160L-4	15.0	380/660	28.2/16.6	1460	≥89.4	0.85	2.2	7.0	2.2
MS-180M-4	18.5	380/660	33.7/19.8	1470	≥90.0	0.85	2.2	7.5	2.2
MS-180L-4	22.0	380/660	40.1/23.5	1470	≥90.5	0.85	2.2	7.5	2.2

TECHNICAL DATA (HIGH POWER WITH SMALL FRAME)

Model	Power (kW)	Voltage (V)	Current (A)	Speed (r.p.m.)	Eff (%)	Power factor	Tstart/Tn	Tmax/Tn	Ist/In	Net weight (kg)
MS633-2	0.37	220/380	2.0/1.15	2800	68	0.74	2.5	2.7	6	5.6
MS713-2	0.75	220/380	3.6/2.1	2800	73	0.8	2.6	2.9	6	8.1
MS803-2	1.5	220/380	5.87/3.4	2800	77	0.85	2.8	3.1	6	12
MS90L2-2	3	220/380	11.64/6.74	2800	80	0.83	3	3.2	6	19.5
MS100L2-2	4	220/380	13.6/7.87	2850	82	0.87	2.5	2.7	7	28.8
MS112M2-2	5.5	380/660	12.5/7.3	2890	84	0.88	2.5	2.7	7	36
MS112M3-2	7.5	380/660	15.4/8.9	2890	85	0.88	2.5	2.7	7.5	39
MS132M1-2	11	380/660	23/13.3	2900	85	0.89	2.5	2.7	7.5	60.5
MS132M2-2	15	380/660	30/17.4	2900	85	0.89	2.5	2.7	7.5	68
MS633-4	0.25	220/380	1.52/0.88	1360	60	0.69	2.2	2.4	3.5	5.4
MS713-4	0.55	220/380	2.73/1.58	1355	68	0.72	2.2	2.4	5	8.1
MS803-4	1.1	220/380	5/2.9	1400	75	0.76	2.3	2.5	5	13.2
MS90L2-4	1.85	220/380	7.77/4.5	1400	77	0.79	2.5	2.7	5.5	18
MS100L3-4	4	220/380	15.5/9	1400	81	0.8	2.5	2.7	6	29.1
MS112M2-4	5.5	380/660	12.2/7.06	1410	82	0.81	2.7	3	7	36.7
MS132M2-4	9.2	380/660	19.5/11.3	1420	85	0.83	2.7	3	7	61.5
MS132M3-4	11	380/660	22/12.7	1420	85	0.85	2.5	2.7	7.5	67

M/S

SERIES THREE-PHASE ASYNCHRONOUS MOTOR

ALUMINUM HOUSING



Conform to the IEC standard
Be made of selected quality materials, latest design in entirety.
Good performance, low noise, little vibration, and safety and reliable operation.
Nice appearance, light weight.
Be maintained very conveniently, simple construction.
Be used for general drive.

MOTOR FEATURES

- Utilise IP54 enclosures, IP55 on request
- Multiple feet locations
- Aluminium frame, end shields and base
- High strength cable gland
- Shaft key and protector supplied
- Superior paint finish
- Motors made to heavy duty service factors
- Can be made with stainless steel shaft
- Motors made for continuous S1 duty
- Utilise Vacuum impregnated Class B insulation
- Class F insulation on request
- High performance and efficiency

CUSTOMER BENEFITS

- Water dust and vermin resistant
- Quiet operation
- Electricity saving
- Easy installation (bolt on feet or brackets as required)
- Corrosion resistant
- Dependable
- Superior life
- Reliable in country, city or factory environments

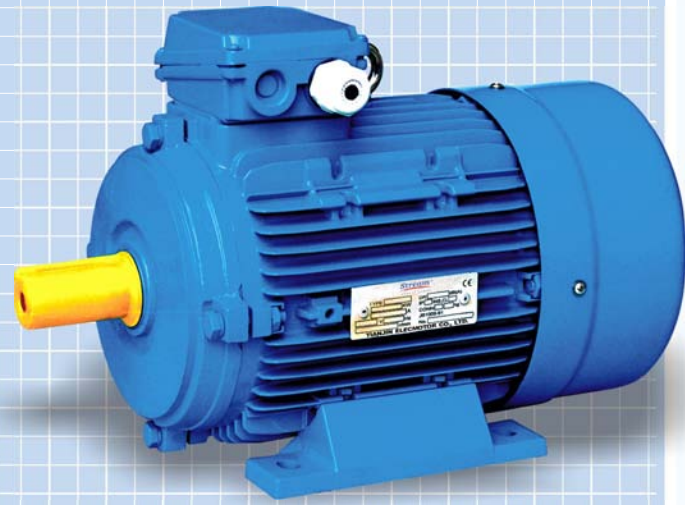

INSTALLATION DIMENSIONS

IMB3

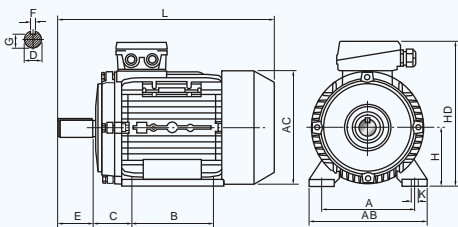

IMB14

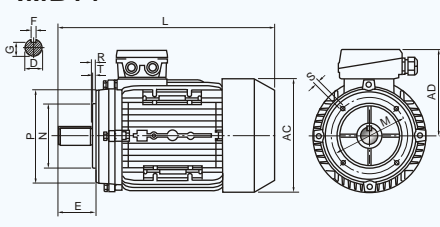

IMB5

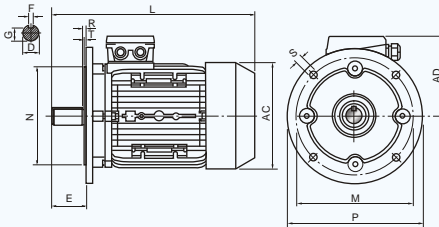

Frame Size	Mounting Dimensions (mm)																Frame Dimensions (mm)									
	IMB3				IMB14				IMB5								AB	AC	AD	HD	L					
	A	B	C	D	E	F	G	H	K	M	N	P	R	S	T	M	N	P	R	S	T	AB	AC	AD	HD	L
56	90	71	36	9	20	3	7.2	56	5.8	65	50	80	0	M5	2.5	98	80	120	0	7	3.0	110	120	110	155	195
63	100	80	40	11	23	4	8.5	63	7	75	60	90	0	M5	2.5	115	95	140	0	10	3.0	130	130	115	165	230
71	112	90	45	14	30	5	11	71	7	85	70	105	0	M6	2.5	130	110	160	0	10	3.5	145	145	125	185	255
80	125	100	50	19	40	6	15.5	80	10	100	80	120	0	M6	3.0	165	130	200	0	12	3.5	160	165	135	215	295
90S	140	100	56	24	50	8	20	90	10	115	95	140	0	M8	3.0	165	130	200	0	12	3.5	180	185	145	235	335
90L	140	125	56	24	50	8	20	90	10	115	95	140	0	M8	3.0	165	130	200	0	12	3.5	180	185	145	235	360
100L	160	140	63	28	60	8	24	100	12	130	110	160	0	M8	3.5	215	180	250	0	15	4.0	205	215	170	255	380
112M	190	140	70	28	60	8	24	112	12	130	110	160	0	M8	3.5	215	180	250	0	15	4.0	245	240	180	285	400
132S	216	140	89	38	80	10	33	132	12	165	130	200	0	M10	4.0	265	230	300	0	15	4.0	280	275	195	325	475
132M	216	178	89	38	80	10	33	132	12	165	130	200	0	M10	4.0	265	230	300	0	15	4.0	280	275	195	325	515
160M	254	210	108	43	110	12	37	160	15	215	180	250	0	M12	4.0	300	250	350	0	15	5.0	320	330	255	420	615
160L	254	254	108	42	110	12	37	160	15	215	180	250	0	M12	4.0	300	250	350	0	15	5.0	320	330	255	420	670
180M	279	241	121	48	110	14	42.5	180	15	265	230	300	0	M15	4.0	300	250	350	0	19	5.0	355	380	280	455	700
180L	279	279	121	48	110	14	42.5	180	15	265	230	300	0	M15	4.0	300	250	350	0	19	5.0	355	380	280	455	740

Model	Power (kW)	Voltage (V)	Current (A)	Speed (r.p.m.)	Eff (%)	Power factor	Tstart/Tn	Tmax/Tn	Ist/In
MS561-2	0.09	220/380	0.57/0.33	2800	62	0.68	2.3	2.4	6
MS562-2	0.12	220/380	0.67/0.38	2800	67	0.71	2.3	2.4	6
MS631-2	0.18	220/380	0.91/0.53	2800	69	0.75	2.2	2.4	6
MS632-2	0.25	220/380	1.17/0.68	2800	72	0.78	2.2	2.4	6
MS711-2	0.37	220/380	1.65/0.95	2800	73.5	0.80	2.2	2.4	6
MS712-2	0.55	220/380	2.33/1.35	2800	75.5	0.82	2.2	2.4	6
MS801-2	0.75	220/380	3.03/1.75	2800	76.5	0.85	2.2	2.4	6
MS802-2	1.1	220/380	4.42/2.55	2800	77	0.85	2.2	2.4	6
MS90S-2	1.5	220/380	6.01/3.84	2800	77	0.85	2.2	2.4	6
MS90L-2	2.2	220/380	8.61/4.98	2800	78	0.86	2.2	2.4	6
MS100L-2	3.0	220/380	11.1/6.4	2870	82	0.87	2.2	2.3	7
MS112M-2	4.0	380/660	8.2/4.7	2890	85.5	0.87	2.2	2.3	7
MS132S1-2	5.5	380/660	11/6.3	2900	85.5	0.88	2.0	2.2	7
MS132S2-2	7.5	380/660	15/8.6	2900	86.2	0.88	2.0	2.2	7
MS160M1-2	11.0	380/660	21.3/12.2	2930	88	0.88	2.0	2.2	7
MS160M2-2	15.0	380/660	28.7/16.4	2930	89	0.89	2.0	2.2	7
MS160L-2	18.5	380/660	34.6/19.8	2930	90	0.90	2.0	2.2	7
MS180M-2	22.0	380/660	40.9/23.4	2930	90.5	0.90	2.0	2.2	7
MS561-4	0.06	220/380	0.49/0.28	1400	56	0.58	2.3	2.4	6
MS562-4	0.09	220/380	0.67/0.39	1400	58	0.61	2.3	2.4	6
MS631-4	0.12	220/380	0.84/0.48	1400	60	0.63	2.2	2.4	6
MS632-4	0.18	220/380	1.12/0.65	1400	64	0.66	2.2	2.4	6
MS711-4	0.25	220/380	1.44/0.83	1400	67	0.68	2.2	2.4	6
MS712-4	0.37	220/380	1.94/1.12	1400	69.5	0.72	2.2	2.4	6
MS801-4	0.55	220/380	2.69/1.56	1400	73.5	0.73	2.2	2.4	6
MS802-4	0.75	220/380	3.48/2.01	1400	75.5	0.75	2.2	2.4	6
MS90S-4	1.1	220/380	4.74/2.75	1400	78	0.78	2.2	2.4	6
MS90L-4	1.5	220/380	6.31/3.65	1400	79	0.79	2.2	2.4	6
MS100L1-4	2.2	220/380	8.6/5.0	1430	81	0.82	2.2	2.3	7
MS100L2-4	3.0	220/380	11.7/6.8	1430	82.5	0.81	2.2	2.3	7
MS112M-4	4.0	380/660	8.8/5.1	1440	84.5	0.82	2.2	2.3	7
MS132S-4	5.5	380/660	12/6.9	1440	85.5	0.84	2.2	2.2	7
MS132M-4	7.5	380/660	15/8.6	1440	87	0.85	2.2	2.2	7
MS160M-4	11	380/660	22.3/12.7	1460	88	0.85	2.0	2.2	7
MS160L-4	15	380/660	30/17.1	1460	89	0.85	2.0	2.2	7
MS180M-4	18.5	380/660	36.4/20.8	1470	90.5	0.85	2.2	2.2	7.5
MS180L-4	22	380/660	43.1/24.6	1470	91	0.85	2.2	2.2	7.5
MS90S-6	0.75	220/380	4.0/2.3	910	72.5	0.70	2.2	2.2	5.5
MS90L-6	1.1	220/380	5.5/3.2	910	73.5	0.72	2.2	2.2	5.5
MS100L-6	1.5	220/380	6.9/4.0	940	77.5	0.74	2.2	2.2	6
MS112M-6	2.2	220/380	9.7/5.6	940	80.5	0.74	2.2	2.2	6
MS132S-6	3.0	220/380	12.4/7.2	960	83	0.76	2.0	2.0	6.5
MS132M1-6	4.0	380/660	9.4/5.4	960	84	0.77	2.0	2.0	6.5
MS132M2-6	5.5	380/660	13/7.5	960	85.3	0.78	2.0	2.0	6.5
MS160M-6	7.5	380/660	16.5/9.43	970	86	0.80	2.0	2.0	6.5
MS160L-6	11.0	380/660	24.1/13.8	970	87.5	0.79	2.0	2.0	6.5
MS180L-6	15.0	380/660	31.5/18	970	89	0.81	2.0	2.0	7.0
MS132S-8	2.2	220/380	10/5.8	710	85.5	0.71	2.0	2.0	5.5
MS132M-8	3.0	220/380	13.3/7.7	710	82	0.72	2.0	2.0	5.5
MS160M1-8	4.0	380/660	10.2/5.8	720	81	0.73	2.0	2.0	6.0
MS160M2-8	5.5	380/660	13.6/7.8	720	83	0.74	2.0	2.0	6.0
MS160L-8	7.5	380/660	17.7/10.1	720	85.5	0.75	2.0	2.0	6.0
MS180L-8	11	380/660	25.1/14.3	730	87.5	0.76	2.0	2.0	6.5

MC

SERIES SING-PHASE CAPACITOR START ASYNCHRONOUS MOTOR

ALUMINUM HOUSING



Conform to the IEC standard
Be made of selected quality materials, latest design in entirety.
Good performance, low noise, little vibration, and safety and reliable operation.
Nice appearance, light weight.
Be maintained very conveniently, simple construction.
Higher starting torque, 2.5 times more than the rated torque.
Be used in a multitude of application where the higher starting torque is demanded, such as air-compressors, pumps, refrigerators, medical apparatus, instruments, and many other machines needing full-load start.

MOTOR FEATURES

- Utilise IP54 enclosures, IP55 on request
- Multiple feet locations
- Aluminium frame, end shields and base
- High strength cable gland
- Shaft key and protector supplied
- Superior paint finish
- Motors made to heavy duty service factors
- Can be made with stainless steel shaft
- Motors made for continuous S1 duty
- Utilise Vacuum impregnated Class B insulation
- Class F insulation on request
- High performance and efficiency

CUSTOMER BENEFITS

- Water dust and vermin resistant
- Quiet operation
- Electricity saving
- Easy installation (bolt on feet or brackets as required)
- Corrosion resistant
- Dependable
- Superior life
- Reliable in country, city or factory environments

TECHNICAL DATA

Model	Power (kW)	Voltage (V)	Current (A)	Speed (r.p.m.)	Eff (%)	Power factor	Tstart/Tn	Tmax/Tn	Start current (A)	Net weight (kg)
MC711-2	0.18	220	1.89	2800	60	0.72	3.0	1.8	12	6.5
MC712-2	0.25	220	2.40	2800	64	0.74	3.0	1.8	15	6.8
MC801-2	0.37	220	3.36	2800	65	0.77	2.8	1.8	21	8.3
MC802-2	0.55	220	4.65	2800	68	0.79	2.8	1.8	29	9
MC90S-2	0.75	220	6.09	2800	70	0.80	2.5	1.8	37	12.5
MC90L-2	1.10	220	8.68	2800	72	0.80	2.5	1.8	60	14
MC100L1-2	1.50	220	11.38	2900	74	0.81	2.5	1.8	80	22.5
MC100L2-2	2.20	220	16.46	2900	75	0.81	2.2	1.8	120	25.5
MC112M-2	3.00	220	21.88	2900	76	0.82	2.2	1.8	150	26
MC711-4	0.12	220	1.88	1400	50	0.58	3.0	1.8	9	6.5
MC712-4	0.18	220	2.49	1400	53	0.62	2.8	1.8	12	6.7
MC801-4	0.25	220	3.11	1400	58	0.63	2.8	1.8	15	8.9
MC802-4	0.37	220	4.24	1400	62	0.64	2.5	1.8	21	9.6
MC90S-4	0.55	220	5.49	1400	66	0.69	2.5	1.8	29	12.5
MC90L-4	0.75	220	6.87	1400	68	0.73	2.5	1.8	37	15
MC100L1-4	1.10	220	9.52	1450	71	0.74	2.5	1.8	60	23
MC100L2-4	1.50	220	12.45	1450	73	0.75	2.5	1.8	80	27
MC112M-4	2.20	220	17.78	1450	74	0.76	2.2	1.8	120	35

INSTALLATION DIMENSIONS

IMB3

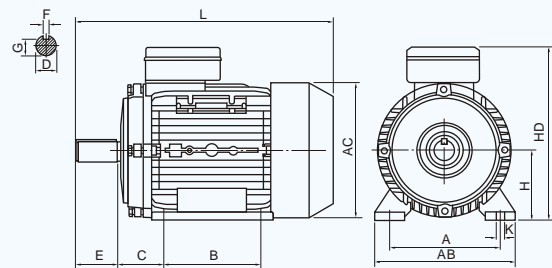

IMB14

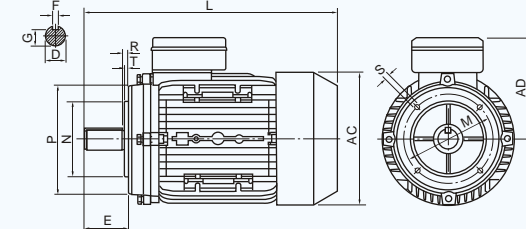

IMB5

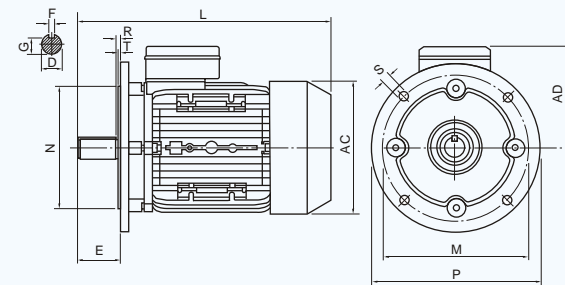

INSTALLATION DIMENSIONS

Frame Size	Mounting Dimensions (mm)																			Frame Dimensions (mm)						
	IMB3									IMB14						IMB5				AB	AC	AD	HD	L		
	A	B	C	D	E	F	G	H	K	M	N	P	R	S	T	M	N	P	R						S	T
71	112	90	45	14	30	5	11	71	7	85	70	105	0	M6	2.5	130	110	160	0	10	3.5	145	145	125	205	255
80	125	100	50	19	40	6	15.5	80	10	100	80	120	0	M6	3.0	165	130	200	0	12	3.5	160	165	135	235	295
90S	140	100	56	24	50	8	20	90	10	115	95	140	0	M8	3.0	165	130	200	0	12	3.5	180	185	145	265	335
90L	140	125	56	24	50	8	20	90	10	115	95	140	0	M8	3.0	165	130	200	0	12	3.5	180	185	145	265	360
100L	160	140	63	28	60	8	24	100	12	-	-	-	-	-	-	215	180	250	0	15	4.0	205	215	170	280	380
112M	190	140	70	28	60	8	24	112	12	-	-	-	-	-	-	215	180	250	0	15	4.0	245	240	180	310	400

MY

SERIES SING-PHASE CAPACITOR RUN ASYNCHRONOUS MOTOR

ALUMINUM HOUSING



Conform to the IEC standard
Be made of selected quality materials, latest design in entirety.
Good performance, low noise, little vibration, and safety and reliable operation.
Nice appearance, light weight.
Be maintained very conveniently, simple construction.
Lower starting torque, 0.3 to 0.7 times more than the rated torque.
Be used in a multitude of application where the lower starting torque is demanded, such as home electric appliances, pumps, fans and recording meters, etc.

MOTOR FEATURES

- Utilise IP54 enclosures, IP55 on request
- Multiple feet locations
- Aluminium frame, end shields and base
- High strength cable gland
- Shaft key and protector supplied
- Superior paint finish
- Motors made to heavy duty service factors
- Can be made with stainless steel shaft
- Motors made for continuous S1 duty
- Utilise Vacuum impregnated Class B insulation
- Class F insulation on request
- High performance and efficiency

CUSTOMER BENEFITS

- Water dust and vermin resistant
- Quiet operation
- Electricity saving
- Easy installation (bolt on feet or brackets as required)
- Corrosion resistant
- Dependable
- Superior life
- Reliable in country, city or factory environments

TECHNICAL DATA

Model	Power (kW)	Voltage (V)	Current (A)	Speed (r.p.m.)	Eff (%)	Power factor	Tstart/Tn	Tmax/Tn	Start current (A)	Net weight (kg)
MY631-2	0.18	220	1.48	2800	60	0.92	0.4	1.7	5	3.9
MY632-2	0.25	220	1.96	2800	63	0.92	0.4	1.7	7	4.4
MY711-2	0.37	220	2.73	2800	67	0.92	0.35	1.7	10	6.2
MY712-2	0.55	220	3.88	2800	70	0.92	0.35	1.7	15	6.5
MY801-2	0.75	220	5.15	2800	72	0.92	0.33	1.7	20	8.3
MY802-2	1.10	220	7.02	2800	75	0.95	0.33	1.7	30	9
MY90S-2	1.50	220	9.44	2800	76	0.95	0.3	1.7	45	13
MY90L-2	2.20	220	13.67	2800	77	0.95	0.3	1.7	65	15
MY631-4	0.12	220	1.10	1400	55	0.90	0.4	1.7	3.5	4
MY632-4	0.18	220	1.62	1400	56	0.90	0.4	1.7	5	4.5
MY711-4	0.25	220	2.02	1400	61	0.92	0.35	1.7	7	6.1
MY712-4	0.37	220	2.95	1400	62	0.92	0.35	1.7	10	7
MY801-4	0.55	220	4.25	1400	64	0.92	0.35	1.7	15	9.5
MY802-4	0.75	220	5.45	1400	68	0.92	0.32	1.7	20	10
MY90S-4	1.10	220	7.45	1400	71	0.95	0.32	1.7	30	13
MY90L-4	1.50	220	9.83	1400	73	0.95	0.3	1.7	45	16

INSTALLATION DIMENSIONS

IMB3

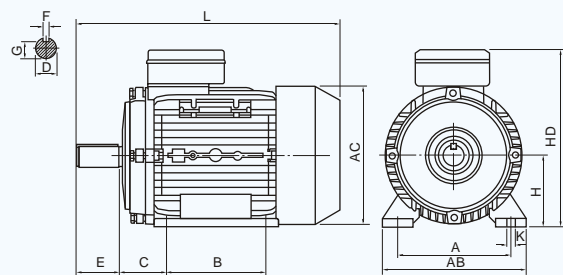

IMB14

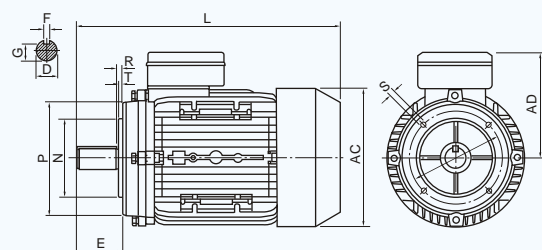

IMB5

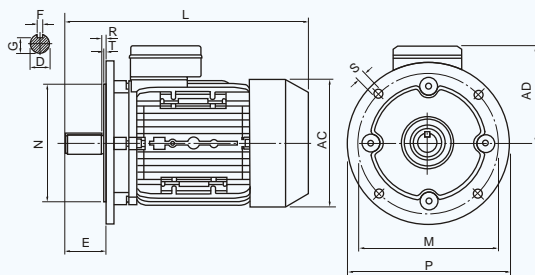

INSTALLATION DIMENSIONS

Frame Size	Mounting Dimensions (mm)																Frame Dimensions (mm)									
	IMB3								IMB14				IMB5				AB	AC	AD	HD	L					
	A	B	C	D	E	F	G	H	K	M	N	P	R	S	T	M						N	P	R	S	T
63	100	80	40	11	23	4	8.5	63	7	75	60	90	0	M5	2.5	115	95	140	0	10	3.0	130	130	115	185	230
71	112	90	45	14	30	5	11	71	7	85	70	105	0	M6	2.5	130	110	160	0	10	3.5	145	145	125	205	255
80	125	100	50	19	40	6	15.5	80	10	100	80	120	0	M6	3.0	165	130	200	0	12	3.5	160	165	135	235	295
90S	140	100	56	24	50	8	20	90	10	115	95	140	0	M8	3.0	165	130	200	0	12	3.5	180	185	145	265	335
90L	140	125	56	24	50	8	20	90	10	115	95	140	0	M8	3.0	165	130	200	0	12	3.5	180	185	145	265	360

MIL

SERIES SING-PHASE DUAL-CAPACITOR ASYNCHRONOUS MOTOR

ALUMINUM HOUSING



Conform to the IEC standard
Be made of selected quality materials, latest design in entirety.
Good performance, low noise, little vibration, and safety and reliable operation.
Nice appearance, light weight.
Be maintained very conveniently, simple construction.
Good general performance, 1.8 to 2.5 times more than the rated torque.

MOTOR FEATURES

- Utilise IP54 enclosures, IP55 on request
- Multiple feet locations
- Aluminium frame, end shields and base
- High strength cable gland
- Shaft key and protector supplied
- Superior paint finish
- Motors made to heavy duty service factors
- Can be made with stainless steel shaft
- Motors made for continuous S1 duty
- Utilise Vacuum impregnated Class B insulation
- Class F insulation on request
- High performance and efficiency

CUSTOMER BENEFITS

- Water dust and vermin resistant
- Quiet operation
- Electricity saving
- Easy installation (bolt on feet or brackets as required)
- Corrosion resistant
- Dependable
- Superior life
- Reliable in country, city or factory environments

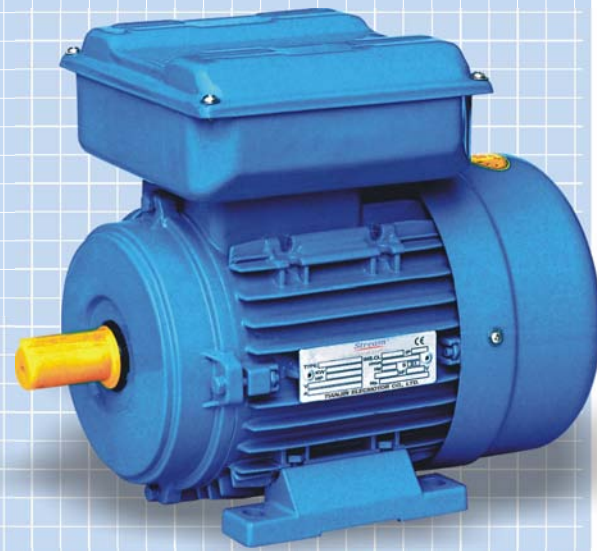

TECHNICAL DATA

Model	Power (kW)	Voltage (V)	Current (A)	Speed (r.p.m.)	Eff (%)	Power factor	Tstart/Tn	Tmax/Tn	Start current (A)	Net weight (kg)
ML711-2	0.37	220	2.73	2800	67	0.92	2.3	1.8	16	7
ML712-2	0.55	220	3.88	2800	70	0.92	2.5	1.8	21	8
ML801-2	0.75	220	5.15	2800	72	0.92	2.5	1.8	30	8.5
ML802-2	1.10	220	7.02	2800	75	0.95	2.5	1.8	40	9.5
ML90S-2	1.50	220	9.44	2800	76	0.95	2.5	1.8	55	12.5
ML90L-2	2.20	220	13.67	2800	77	0.95	2.5	1.8	80	14
ML100L-2	3.00	220	18.2	2800	79	0.95	2.5	1.8	110	20.5
ML711-4	0.25	220	1.99	1400	62	0.92	2.5	1.8	12	6.9
ML712-4	0.37	220	2.81	1400	65	0.92	2.5	1.8	16	8.1
ML801-4	0.55	220	4.0	1400	68	0.92	2.5	1.8	21	8.9
ML802-4	0.75	220	5.22	1400	71	0.92	2.5	1.8	30	9.6
ML90S-4	1.10	220	7.2	1400	73	0.95	2.5	1.8	40	13
ML90L-4	1.50	220	9.57	1400	75	0.95	2.5	1.8	55	16
ML100L1-4	2.20	220	13.9	1400	76	0.95	2.5	1.8	80	23
ML100L2-4	3.00	220	18.6	1400	77	0.95	2.5	1.8	110	27

INSTALLATION DIMENSIONS

IMB3

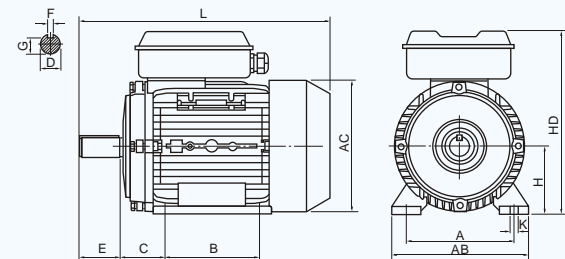

IMB14

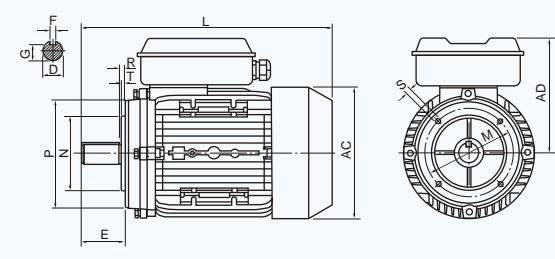

IMB5

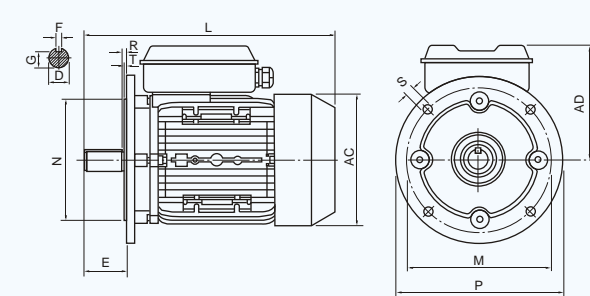

INSTALLATION DIMENSIONS

Frame Size	Mounting Dimensions (mm)																				Frame Dimensions (mm)					
	IMB3										IMB14					IMB5					AB	AC	AD	HD	L	
	A	B	C	D	E	F	G	H	K	M	N	P	R	S	T	M	N	P	R	S						T
71	112	90	45	14	30	5	11	71	7	85	70	105	0	M6	2.5	130	110	160	0	10	3.5	145	145	125	210	255
80	125	100	50	19	40	6	15.5	80	10	100	80	120	0	M6	3.0	165	130	200	0	12	3.5	160	165	135	240	295
90S	140	100	56	24	50	8	20	90	10	115	95	140	0	M8	3.0	165	130	200	0	12	3.5	180	185	145	270	335
90L	140	125	56	24	50	8	20	90	10	115	95	140	0	M8	3.0	165	130	200	0	12	3.5	180	185	145	270	360
100L	160	140	63	28	60	8	24	100	12	-	-	-	-	-	-	215	180	250	0	15	4.0	205	215	170	280	380

Y2

SERIES THREE-PHASE ASYNCHRONOUS MOTOR



These three phase motors are made to IEC standards. These are superior motors having excellent power factors efficiencies and starting torques. These motors are widely used in the agricultural, pumping, manufacturing and building service industries.

MOTOR FEATURES

- IP54 enclosure, IP55 available on request
- Class F insulation, Class H available on request
- 380/415 Volt 50/60 Hz windings
- High quality magnet wire
- Vacuum varnish impregnation for superior tropic proof insulation
- Continuous SI operation
- Industrial type service factors
- Heavy duty ball bearings
- High strength cast iron frame
- Balanced rotors

CUSTOMER BENEFITS

- Water dust and vermin resistant
- Quiet operation
- Corrosion resistant
- Reliable in country, city or factory environments
- Very low vibration
- Very low power consumption
- Superior life



INSTALLATION DIMENSIONS

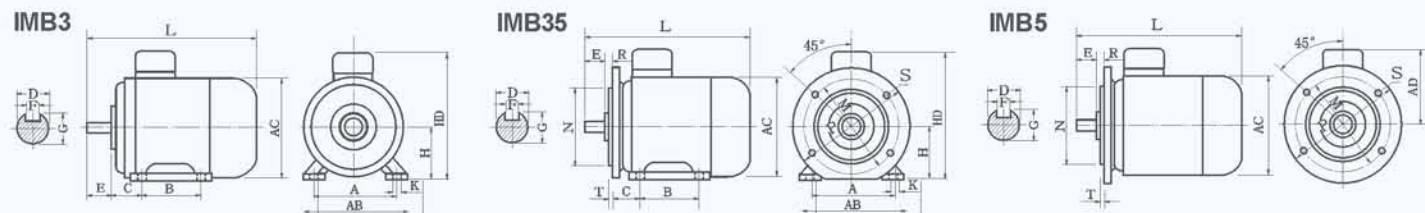

Frame Size	Mounting Dimensions(mm)													Frame Dimensions(mm)										
	A	B	C	D		E		F		G		H	K	M	N	P	R	S	T	AB	AC	AD	HD	L
				2P	4,6,8,10P	2P	4,6,8,10P	2P	4,6,8,10P	2P	4,6,8,10P												2P	4,6,8,10P
63	100	80	40	11	23	4	8.5	63	7	115	95	140	0	10	3	135	130	70	180				230	
71	112	90	45	14	30	5	11	71	7	130	110	160	0	10	3	150	145	80	195				255	
80	125	100	50	19	40	6	15.5	80	10	165	130	200	0	12	3.5	165	175	145	220				295	
90S	140	100	56	24	50	8	20	90	10	165	130	200	0	12	3.5	180	195	155	250				320	
90L	140	125	56	24	50	8	20	90	10	165	130	200	0	12	3.5	180	195	155	250				345	
100L	160	140	63	28	60	8	24	100	12	215	180	250	0	15	4	205	215	180	270				385	
112M	190	140	70	28	60	8	24	112	12	215	180	250	0	15	4	230	240	190	300				400	
132S	216	140	89	38	80	10	33	132	12	265	230	300	0	15	4	270	275	210	345				470	
132M	216	178	89	38	80	10	33	132	12	265	230	300	0	15	4	270	275	210	345				510	
160M	254	210	108	42	110	12	37	160	15	300	250	350	0	19	5	320	330	255	420				615	
160L	254	254	108	42	110	12	37	160	15	300	250	350	0	19	5	320	330	255	420				670	
180M	279	241	121	48	110	14	42.5	180	15	300	250	350	0	19	5	355	380	280	455				700	
180L	279	279	121	48	110	14	42.5	180	15	300	250	350	0	19	5	355	380	280	455				740	
200L	318	305	133	55	110	16	49	200	19	350	300	400	0	19	5	395	420	305	505				770	
225S	356	286	149	60	140	18	53	225	19	400	350	450	0	19	5	435	470	335	560				820	
225M	356	311	149	55	140	16	49	225	19	400	350	450	0	19	5	435	470	335	560			815	845	
250M	406	349	168	60	140	18	53	250	24	500	450	550	0	19	5	490	510	370	615				910	
280S	457	368	190	65	140	18	58	280	24	500	450	550	0	19	5	550	580	410	680				985	
280M	457	419	190	65	140	18	58	280	24	500	450	550	0	19	5	550	580	410	680				1035	
315S	508	406	216	65	170	18	67.5	315	28	600	550	660	0	24	6	635	645	440	845			1185	1215	
315M	508	457	216	65	170	18	67.5	315	28	600	550	660	0	24	6	635	645	440	845			1295	1325	
315L	508	508	216	65	170	18	67.5	315	28	600	550	660	0	24	6	635	645	440	845			1295	1325	
355M	610	560	254	75	140	20	75	355	28	740	680	800	0	24	6	730	710	655	1010			1500	1530	
355L	610	630	254	75	140	20	75	355	28	740	680	800	0	24	6	730	710	655	1010			1500	1530	

TECHNICAL DATA

Model	Power (kW)	Current at 380Vt (A)	Speed (r/min)	Eff. (%)	Power factor	Locked rotor torque / Rated torque	Locked rotor current / Rated current	Max torque / Rated torque
Synchronous Speed 3000r/min(2 poles)50Hz								
Y2-631-2	0.18	0.52	2825	65	0.80	2.2	5.5	2.2
Y2-632-2	0.25	0.69	2840	68	0.81	2.2	5.1	2.2
Y2-711-2	0.37	0.99	2840	70	0.81	2.2	6.0	2.2
Y2-712-2	0.55	1.4	2880	73	0.82	2.2	6.0	2.2
Y2-801-2	0.75	1.8	2890	75	0.83	2.2	6.0	2.2
Y2-802-2	1.1	2.6	2900	77	0.84	2.2	7.0	2.2
Y2-90S-2	1.5	3.4	2900	79	0.84	2.2	7.0	2.2
Y2-90L-2	2.2	4.8	2930	81	0.85	2.2	7.0	2.2
Y2-100L-2	3.0	6.3	2930	83	0.87	2.2	7.0	2.2
Y2-112M-2	4.0	8.1	2930	85	0.88	2.2	8.0	2.2
Y2-132S1-2	5.5	11	2940	86	0.88	2.2	8.0	2.2
Y2-132S2-2	7.5	15	2950	87	0.88	2.2	8.0	2.2
Y2-160M1-2	11.0	21.3	2950	88	0.88	2.0	8.0	2.2
Y2-160M2-2	15.0	28.7	2970	89	0.89	2.0	8.0	2.2
Y2-160L-2	18.5	34.6	2970	90	0.90	2.0	8.0	2.2
Y2-180M-2	22.0	40.9	2970	90.5	0.90	2.0	8.0	2.2
Y2-200L1-2	30.0	55.4	2970	91.2	0.90	2.0	8.0	2.2
Y2-200L2-2	37.0	67.7	2980	92	0.90	2.0	8.0	2.2
Y2-225M-2	45.0	82.3	2980	92.3	0.90	1.8	8.0	2.2
Y2-250M-2	55	101	2980	92.5	0.90	1.8	7.0	2.2
Y2-280S-2	75	134	2980	93.0	0.90	1.8	7.0	2.2
Y2-280M-2	90	160	2980	93.8	0.91	1.8	7.0	2.2
Y2-315S-2	110	195	2980	94.0	0.91	1.8	6.8	2.2
Y2-315M-2	132	233	2980	94.5	0.91	1.8	6.8	2.2
Y2-315L1-2	160	279	2980	94.6	0.92	1.8	6.8	2.2
Y2-315L2-2	200	348	2980	94.8	0.92	1.8	6.8	2.2
Y2-355M-2	250	433	2980	95.3	0.92	1.6	7.0	2.2
Y2-355L-2	315	544	2980	95.6	0.92	1.6	7.1	2.2
Synchronous Speed 1500r/min(4 poles)50Hz								
Y2-631-4	0.12	0.44	1400	57	0.72	2.2	4.5	2.2
Y2-632-4	0.18	0.62	1400	60	0.73	2.2	4.5	2.2
Y2-711-4	0.25	0.79	1400	65	0.74	2.2	5.5	2.2
Y2-712-4	0.37	1.12	1400	67	0.75	2.2	5.5	2.2
Y2-801-4	0.55	1.6	1400	71	0.75	2.2	5.5	2.2
Y2-802-4	0.75	2.0	1400	73	0.77	2.2	6.0	2.2
Y2-90S-4	1.1	2.9	1400	75	0.77	2.2	6.0	2.2
Y2-90L-4	1.5	3.7	1400	78	0.79	2.2	6.0	2.2
Y2-100L1-4	2.2	5.1	1420	80	0.81	2.2	7.0	2.2
Y2-100L2-4	3.0	6.8	1420	82	0.82	2.2	7.0	2.2
Y2-112M-4	4.0	8.8	1440	84	0.82	2.2	7.0	2.2
Y2-132S-4	5.5	11.8	1440	85	0.83	2.2	7.0	2.2
Y2-132M-4	7.5	15.5	1440	87	0.84	2.0	7.0	2.0
Y2-160M-4	11.0	22.3	1460	88	0.85	2.0	7.0	2.2
Y2-160L-4	15.0	30	1460	89	0.85	2.0	7.0	2.2
Y2-180M-4	18.5	36.4	1470	90.5	0.85	2.2	7.5	2.2
Y2-180L-4	22.0	43.1	1470	91	0.85	2.2	7.5	2.2
Y2-200L-4	30.0	57.4	1470	92	0.86	2.2	7.5	2.2
Y2-225S-4	37.0	69.9	1480	92.5	0.87	2.2	7.5	2.2
Y2-225M-4	45.0	84.7	1480	92.8	0.87	2.2	7.5	2.2
Y2-250M-4	55	103	1480	93.0	0.89	2.2	7.0	2.2
Y2-280S-4	75	140	1480	93.8	0.86	2.2	7.0	2.2
Y2-280M-4	90	167	1490	94.2	0.86	2.2	7.0	2.2
Y2-315S-4	110	201	1490	94.5	0.87	2.1	6.9	2.2
Y2-315M-4	132	240	1490	94.8	0.87	2.1	6.9	2.2
Y2-315L1-4	160	287	1490	94.9	0.88	2.1	6.9	2.2
Y2-315L2-4	200	359	1490	95.0	0.88	2.3	6.9	2.2
Y2-355M-4	250	443	1485	95.3	0.88	2.3	6.8	2.2
Y2-355L-4	315	556	1485	95.6	0.89	2.2	6.9	2.2

TECHNICAL DATA

Model	Power (kW)	Current at 380Vt (A)	Speed (r/min)	Eff. (%)	Power factor	Locked rotor torque Rated torque	Locked rotor current Rated current	Max torque Rated torque
Synchronous Speed 1000r/min(6 poles)50Hz								
Y2-711-6	0.18	0.74	900	56	0.66	2.2	4.0	2.2
Y2-712-6	0.25	0.94	900	59	0.68	2.0	4.0	2.2
Y2-801-6	0.37	1.3	900	62	0.70	2.0	5.0	2.2
Y2-802-6	0.55	1.8	900	65	0.72	2.0	5.0	2.2
Y2-90S-6	0.75	2.3	910	69	0.72	2.0	5.5	2.2
Y2-90L-6	1.1	3.2	910	72	0.73	2.0	5.5	2.2
Y2-100L-6	1.5	3.9	940	76	0.76	2.0	5.5	2.2
Y2-112M-6	2.2	5.6	940	79	0.76	2.0	6.5	2.2
Y2-132S-6	3.0	7.4	960	81	0.76	2.0	6.5	2.2
Y2-132M1-6	4.0	9.7	960	82	0.76	2.0	6.5	2.2
Y2-132M2-6	5.5	12.9	960	84	0.77	2.0	6.5	2.0
Y2-160M	7.5	16.5	970	86	0.80	2.0	6.5	2.0
Y2-160L-6	11.0	24.1	970	87.5	0.79	2.0	6.5	2.0
Y2-180L-6	15.0	31.5	970	89	0.81	2.0	7.0	2.0
Y2-200L1-6	18.5	38.5	970	90	0.81	2.0	7.0	2.0
Y2-200L2-6	22.0	44.6	970	90	0.83	2.0	7.0	2.0
Y2-225M-6	30.0	59.3	980	91.5	0.84	2.0	7.0	2.1
Y2-250M-6	37.0	71.0	980	92.0	0.86	2.0	7.0	2.1
Y2-280S-6	45.0	86.0	980	92.5	0.86	2.0	7.0	2.0
Y2-280M-6	55	105	980	92.8	0.86	2.0	7.0	2.0
Y2-315S-6	75	141	990	93.5	0.86	2.0	7.0	2.0
Y2-315M-6	90	169	990	93.8	0.86	2.0	7.0	2.0
Y2-315L1-6	110	206	990	94.0	0.86	2.0	6.7	2.0
Y2-315L2-6	132	244	990	94.2	0.87	2.0	6.7	2.0
Y2-355M1-6	160	292	990	94.5	0.88	1.9	6.7	2.0
Y2-355M2-6	200	365	990	94.7	0.88	1.9	6.7	2.0
Y2-355L-6	250	455	990	94.9	0.88	1.9	6.7	2.0
Synchronous Speed 750r/min(8 poles)50Hz								
Y2-801-8	0.18	0.88	680	51	0.61	1.8	3.3	1.9
Y2-802-8	0.25	1.15	680	54	0.61	1.8	3.3	1.9
Y2-90S-8	0.37	1.5	680	62	0.61	1.8	4.0	1.9
Y2-90L-8	0.55	2.2	700	63	0.61	1.8	4.0	2.2.0
Y2-100L1-8	0.75	2.4	700	71	0.67	1.8	4.0	2.0
Y2-100L2-8	1.1	3.3	700	73	0.69	1.8	5.0	2.0
Y2-112M-8	1.5	4.5	700	75	0.68	1.8	5.0	2.0
Y2-132S-8	2.2	6.0	710	78	0.71	2.0	6.0	2.0
Y2-132M-8	3.0	7.9	710	79	0.73	2.0	6.0	2.0
Y2-160M1-8	4.0	10.2	720	81	0.73	2.0	6.0	2.0
Y2-160M2-4	5.5	13.6	720	83	0.74	2.0	6.0	2.0
Y2-160L-8	7.5	17.7	720	85.5	0.75	2.0	6.0	2.0
Y2-180L-8	11.0	25.1	730	87.5	0.76	2.0	6.5	2.0
Y2-200L-8	15.0	34.0	730	88	0.76	2.0	6.5	2.0
Y2-225S-8	18.5	40.6	740	90.0	0.76	1.9	6.6	2.0
Y2-225M-8	22.0	47.4	740	90.5	0.78	1.9	6.6	2.0
Y2-250M-8	30.0	64.0	740	91.0	0.79	1.9	6.6	2.0
Y2-280S-8	37.0	78.0	740	91.5	0.79	1.9	6.6	2.0
Y2-280M-4	45.0	94.0	740	92.0	0.79	1.9	6.6	2.0
Y2-315S-8	55	111	740	92.8	0.81	1.8	6.6	2.0
Y2-315M-8	75	151	740	93.0	0.81	1.8	6.6	2.0
Y2-315L1-8	90	178	740	93.8	0.82	1.8	6.6	2.0
Y2-315L2-8	110	217	740	94.0	0.82	1.8	6.4	2.0
Y2-355M1-8	132	261	740	93.7	0.82	1.8	6.4	2.0
Y2-355M2-8	160	313	740	94.2	0.82	1.8	6.4	2.0
Y2-355L-8	200	388	740	94.5	0.83	1.8	6.4	2.0
Synchronous Speed 600r/min(10 poles)50Hz								
Y2-315S-10	45	100	590	91.5	0.75	1.5	6.2	2.0
Y2-315M-10	55	121	590	92	0.75	1.5	6.2	2.0
Y2-315L1-10	75	162	590	92.5	0.76	1.5	6.2	2.0
Y2-315L2-10	90	191	590	93	0.77	1.5	6.2	2.0
Y2-355M1-10	110	230	590	93.2	0.78	1.3	6.0	2.0
Y2-355M2-10	132	275	590	93.5	0.78	1.3	6.0	2.0
Y2-355L-10	160	334	590	93.5	0.78	1.3	6.0	2.0

SERIES THREE-PHASE
ASYNCHRONOUS MOTOR



This range of motors are made to IEC standards and incorporate many fine features. These are superior motors that can be used in a multitude of applications in the commercial industrial building service and water treatment fields where superior service quality and reliability is demanded.

MOTOR FEATURES

- Utilise IP44 enclosure, IP54 and IP55 is available on request
- Class B insulation with class F on request
- Motors are made with IC0141 cooling
- Motors are made for continuous S1 duty
- Motors have high start torque
- Motors have high efficiency
- Y connection to 3 Kw
- ▲ connection from 4 to 315 KW
- Voltages on request (220/380V, 380/660V, 220/340V, 220/440, 400/415V)
- Frequency 50 or 60 Hz
- Speed can be single double or multi speed on request
- Tropic proof motors supplied on request
- Flame proof motor supplied on request

CUSTOMER BENEFITS

- Water dust and vermin resistant
- Quiet operation
- Corrosion resistant
- Reliable in country, city or factory environments
- Very low vibration
- Very low power consumption
- Superior life

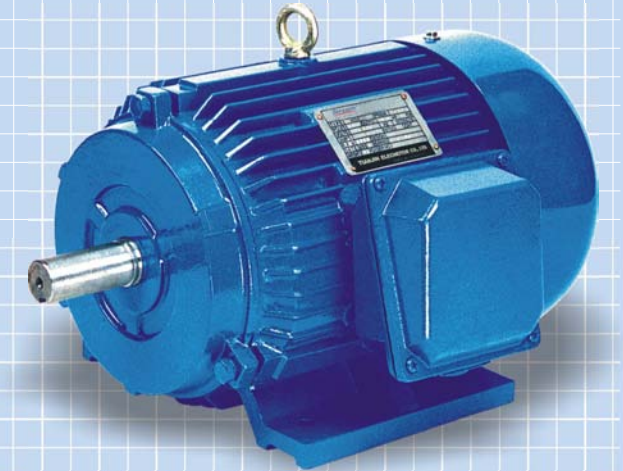

INSTALLATION DIMENSIONS

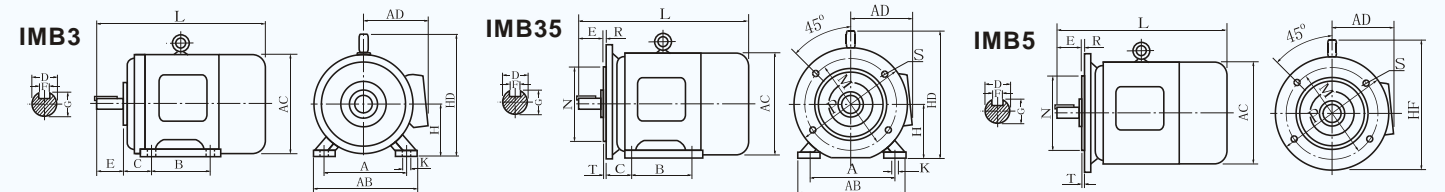

Frame Size	Mounting Dimensions(mm)														Frame Dimensions(mm)										
	A	B	C	D		E		F		G		H	K	M	N	P	R	S	T	AB	AC	AD	HD	L	
				2P	4,6,8,10P	2P	4,6,8,10P	2P	4,6,8,10P	2P	4,6,8,10P														
80	125	100	50	19	40	6	15.5	80	10	165	130	200	0	12	3.5	165	175	150	-	-	-	-	285		
90S	140	100	56	24	50	8	20	90	10	165	130	200	0	12	3.5	180	195	160	-	-	-	-	311		
90L	140	125	56	24	50	8	20	90	10	165	130	200	0	12	3.5	180	195	160	-	-	-	-	335		
100L	160	140	63	28	60	8	24	100	12	215	180	250	0	15	4	205	215	180	245	-	-	-	380		
112M	190	140	70	28	60	8	24	112	12	215	180	250	0	15	4	245	240	190	265	-	-	-	400		
132S	216	140	89	38	80	10	33	132	12	265	230	300	0	15	4	280	275	210	315	-	-	-	475		
132M	216	178	89	38	80	10	33	132	12	265	230	300	0	15	4	280	275	210	315	-	-	-	515		
160M	254	210	108	42	110	12	37	160	15	300	250	350	0	19	5	325	325	255	385	-	-	-	600		
160L	254	254	108	42	110	12	37	160	15	300	250	350	0	19	5	325	325	255	385	-	-	-	645		
180M	279	241	121	48	110	14	42.5	180	15	300	250	350	0	19	5	355	360	285	430	-	-	-	670		
180L	279	279	121	48	110	14	42.5	180	15	300	250	350	0	19	5	355	360	285	430	-	-	-	710		
200L	318	305	133	55	110	16	49	200	19	350	300	400	0	19	5	395	420	315	475	-	-	-	775		
225S	356	286	149	60	140	18	53	225	19	400	350	450	0	19	5	435	450	345	530	-	-	-	820		
225M	356	311	149	55	60	110	140	16	18	49	53	225	19	400	350	450	0	19	5	435	450	345	530	815	845
250M	406	349	168	60	65	140	18	53	58	250	24	500	450	550	0	19	5	490	515	385	575	-	-	930	
280S	457	368	190	65	75	140	18	58	67.5	280	24	500	450	550	0	19	5	550	585	410	640	-	-	1100	
280M	457	419	190	65	75	140	18	58	67.5	280	24	500	450	550	0	19	5	550	585	410	640	-	-	1050	
315S	508	406	216	65	80	140	170	18	22	58	71	315	28	600	550	660	0	24	6	744	645	576	865	1270	
315M	508	457	216	65	80	140	170	18	22	58	71	315	28	600	550	660	0	24	6	744	645	576	865	1340	
315L	508	508	216	65	80	140	170	18	22	58	71	315	28	600	550	660	0	24	6	744	645	576	865	1340	
355M	610	560	254	75	95	140	170	20	25	67.5	86	355	28	740	680	800	0	24	6	730	750	680	860	1515	1545
355L	610	630	254	75	95	140	170	20	25	67.5	86	355	28	740	680	800	0	24	6	730	750	680	860	1515	1545

TECHNICAL DATA

Model	Rated Output		Full Load				Ist/IN Locked current	Tst/TN Locked torque	TM/IN max torque	Net weight (B3) Kg
	KW	HP	Speed (r.p.m.)	Current (A)	Eff. (%)	Power factor (cosn)	Rated current	Rated current	Rated current	
380V 50Hz Synchronous Speed 3000r/min(2poles)										
Y801-2	0.75	1	2830	1.81	75	0.84	6.5	2.2	2.3	17
Y802-2	1.1	1.5	2830	2.52	77	0.86	7.0	2.2	2.3	18
Y90S-2	1.5	2	2840	3.44	78	0.85	7.0	2.2	2.3	22
Y90L-2	2.2	3	2840	4.83	80.5	0.86	7.0	2.2	2.3	26
Y100L-2	3.0	4	2870	6.39	82	0.87	7.0	2.2	2.3	35
Y112M-2	4.0	5.5	2890	8.17	85.5	0.88	7.0	2.2	2.3	45
Y132S1-2	5.5	7.5	2900	11.1	85.5	0.88	7.0	2.0	2.3	67
Y132S2-2	7.5	10	2900	15.0	86.2	0.88	7.0	2.0	2.3	71
Y160M1-2	11	15	2930	21.8	87.2	0.88	7.0	2.0	2.3	118
Y160M2-2	15	20	2930	29.4	88.2	0.89	7.0	2.0	2.3	130
Y160L-2	18.5	25	2930	35.5	89	0.89	7.0	2.0	2.2	150
Y180M-2	22	30	2940	42.2	89	0.89	7.0	2.0	2.2	175
Y200L1-2	30	40	2950	56.9	90	0.89	7.0	2.0	2.2	227
Y200L2-2	37	50	2950	69.8	90.5	0.89	7.0	2.0	2.2	255
Y225M-2	45	60	2970	83.9	91.5	0.89	7.0	2.0	2.2	320
Y250M-2	55	75	2970	103	91.5	0.89	7.0	2.0	2.2	389
Y280S-2	75	100	2970	139	92	0.89	7.0	2.0	2.2	520
Y280M-2	90	125	2970	166	92.5	0.89	7.0	2.0	2.2	577
Y315S-2	110	150	2980	203	92.5	0.89	6.8	1.8	2.2	980
Y315M-2	132	180	2980	242	93	0.89	6.8	1.8	2.2	1080
Y315L1-2	160	220	2980	292	93.5	0.89	6.8	1.8	2.2	1160
Y315L2-2	200	270	2980	365	93.5	0.89	6.8	1.8	2.2	1210
Y355M-2	250	340	2980	444	94.5	0.90	7.0	1.2	2.2	1760
Y355L-2	315	430	2980	556	95	0.90	7.1	1.2	2.2	1900
380V 50Hz Synchronous Speed 1500r/min(4poles)										
Y801-4	0.55	0.75	1390	1.51	73	0.76	6.0	2.4	2.3	17
Y802-4	0.75	1	1390	2.01	74.5	0.76	6.0	2.3	2.3	18
Y90S-4	1.1	1.5	1400	2.75	78	0.78	6.5	2.3	2.3	23
Y90L-4	1.5	2	1400	3.65	79	0.79	6.5	2.3	2.3	27
Y100L1-4	2.2	3	1430	5.03	81	0.82	7.0	2.2	2.3	35
Y100L2-4	3.0	4	1430	6.82	82.5	0.81	7.0	2.2	2.3	38
Y112M-4	4.0	5.5	1440	8.77	84.5	0.82	7.0	2.2	2.3	49
Y132S-4	5.5	7.5	1440	11.6	85.5	0.84	7.0	2.2	2.3	67
Y132M-4	7.5	10	1440	15.4	87	0.85	7.0	2.2	2.3	80
Y160M-4	11	15	1460	22.6	88	0.84	7.0	2.2	2.3	124
Y160L-4	15	20	1460	30.3	88.5	0.85	7.0	2.2	2.3	147
Y180M-4	18.5	25	1470	35.9	91	0.86	7.0	2.0	2.2	169
Y180L-4	22	30	1470	42.5	91.5	0.86	7.0	2.0	2.2	184
Y200L-4	30	40	1470	56.8	92.2	0.87	7.0	2.0	2.2	241
Y225S-4	37	50	1480	70.4	91.8	0.87	7.0	1.9	2.2	300
Y225M-4	45	60	1480	84.2	92.3	0.88	7.0	1.9	2.2	330
Y250M-4	55	75	1480	103	92.6	0.88	7.0	2.0	2.2	400
Y280S-4	75	100	1480	140	92.7	0.88	7.0	1.9	2.2	546
Y280M-4	90	125	1480	164	93.5	0.89	7.0	1.9	2.2	620
Y315S-4	110	150	1480	201	93.5	0.89	6.8	1.8	2.2	1000
Y315M-4	132	180	1490	240	94	0.89	6.8	1.8	2.2	1100
Y315L1-4	160	220	1490	289	94.5	0.89	6.8	1.8	2.2	1140
Y315L2-4	200	270	1490	361	94.5	0.89	6.8	1.8	2.2	1190
Y355M-4	250	340	1485	459	94.7	0.87	6.8	1.4	2.2	1800
Y355L-4	315	430	1485	576	95.2	0.87	6.9	1.4	2.2	1940

TECHNICAL DATA

Model	Rated Output		Full Load				Ist/IN Locked current	Tst/TN Locked torque	TM/IN max torque	Net weight (B3) Kg
	KW	HP	Speed (r.p.m.)	Current (A)	Eff. (%)	Power factor (cosn)	Rated current	Rated current	Rated current	
380V 50Hz Synchronous Speed 1000r/min(6poles)										
Y90S-6	0.75	1	910	2.25	72.5	0.70	5.5	2.0	2.2	23
Y90L-6	1.1	1.5	910	3.16	73.5	0.72	5.5	2.0	2.2	25
Y100L-6	1.5	2	940	3.97	77.5	0.74	6.0	2.0	2.2	33
Y112M-6	2.2	3	940	5.61	80.5	0.74	6.0	2.0	2.2	45
Y132S-6	3.0	4	960	7.23	83	0.76	6.5	2.0	2.2	63
Y132M1-6	4.0	5.5	960	9.40	84	0.77	6.5	2.0	2.2	73
Y132M2-6	5.5	7.5	960	12.6	85.3	0.78	6.5	2.0	2.2	84
Y160M-6	7.5	10	970	17.0	86	0.78	6.5	2.0	2.0	119
Y160L-6	11	15	970	24.6	87	0.78	6.5	2.0	2.0	147
Y180L-6	15	20	970	31.4	89.5	0.81	6.5	1.8	2.0	181
Y200L1-6	18.5	25	970	37.7	89.8	0.83	6.5	1.8	2.0	215
Y200L2-6	22	30	970	44.6	90.2	0.83	6.5	1.8	2.0	235
Y225M-6	30	40	980	59.5	92	0.85	6.5	1.7	2.0	294
Y250M-6	37	50	980	72	90.8	0.86	6.5	1.8	2.0	390
Y280S-6	45	60	980	85.4	92	0.87	6.5	1.8	2.0	506
Y280M-6	55	75	980	104	92	0.87	6.5	1.8	2.0	553
Y315S-6	75	100	990	141	92.8	0.87	6.5	1.6	2.0	990
Y315M-6	90	125	990	169	93.2	0.87	6.5	1.6	2.0	1080
Y315L1-6	110	150	990	206	93.5	0.87	6.5	1.6	2.0	1150
Y315L2-6	132	180	990	246	93.8	0.87	6.5	1.6	2.0	1210
Y355M1-6	160	220	990	300	94.1	0.86	6.7	1.3	2.0	1620
Y355M2-6	200	270	990	374	94.3	0.86	6.7	1.3	2.0	1750
Y355L-2	250	340	990	465	94.7	0.86	6.7	1.3	2.0	1990
380V 50Hz Synchronous Speed 750r/min(8poles)										
Y132S-8	2.2	3	710	5.85	80.5	0.71	5.5	2.0	2.0	63
Y132M-8	3.0	4	710	7.72	82	0.72	5.5	2.0	2.0	79
Y160M1-8	4.0	5.5	720	9.91	84	0.73	6.0	2.0	2.0	118
Y160M2-8	5.5	7.5	720	13.3	85	0.74	6.0	2.0	2.0	119
Y160L-8	7.5	10	720	17.7	86	0.75	5.5	2.0	2.0	145
Y180L-8	11	15	730	24.8	87.5	0.77	6.0	1.7	2.0	172
Y200L-8	15	20	730	34.1	88	0.76	6.0	1.8	2.0	220
Y225S-8	18.5	25	730	41.3	89.5	0.76	6.0	1.7	2.0	263
Y225M-8	22	30	730	47.6	90	0.78	6.0	1.8	2.0	292
Y250M-8	30	40	740	63.0	90.5	0.80	6.0	1.8	2.0	390
Y280S-8	37	50	740	78.2	91	0.79	6.0	1.8	2.0	508
Y280M-8	45	60	740	93.2	91.7	0.80	6.0	1.8	2.0	533
Y315S-8	55	75	740	114	92	0.80	6.5	1.6	2.0	1000
Y315M-8	75	100	740	152	92.5	0.81	6.5	1.6	2.0	1100
Y315L1-8	90	125	740	179	93	0.82	6.5	1.6	2.0	1160
Y315L2-8	110	150	740	218	93.3	0.82	6.3	1.6	2.0	1230
Y355M1-8	132	180	740	260	93.8	0.81	6.3	1.3	2.0	1700
Y355M2-8	160	220	740	314	94.0	0.81	6.3	1.3	2.0	1780
Y355L-8	200	270	740	392	94.3	0.81	6.3	1.3	2.0	2000
380V 50Hz Synchronous Speed 600r/min(10poles)										
Y315S-10	45	60	590	101	91.5	0.74	6.0	1.4	2.0	990
Y315M-10	55	75	590	123	92	0.74	6.0	1.4	2.0	1150
Y315L2-10	75	100	590	164	92.5	0.75	6.0	1.4	2.0	1220
Y355M1-10	90	120	590	190	93	0.77	6.0	1.2	2.0	1530
Y355M2-10	110	150	590	230	93.2	0.78	6.0	1.2	2.0	1640
Y355L-10	132	180	590	275	93.5	0.78	6.0	1.2	2.0	1690

YD

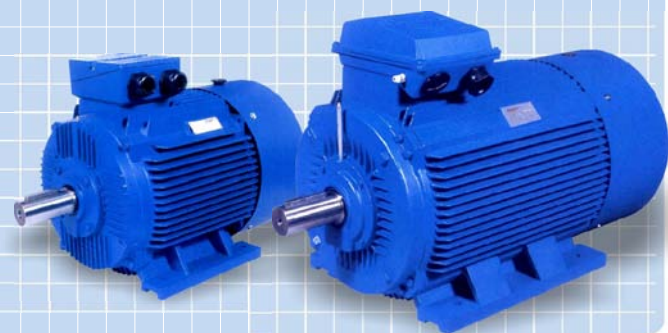

THREE-PHASE MULTI-SPEED MOTORS

YD series three-phase multi-speed induction motors are one of the derived series of Y2 series induction motors of our national uniform design, it has following features: excellent performance, attractive appearance and good interchangeability for the same kind of products abroad. The protection class is IP.

The motors are designed in three types: double speed, three speed and four speed. These speed rates can be changed in stages. The motors are widely used on applications in the equipments where the changed rates in stages are needed, such as mechanism, mine, metallurgy, textiles, printing and dyeing, chemical industry, agricultural machinery, etc. They can also simplify or take the place of reduction gearbox in the mechanical drive lines.

ENVIRONMENT CONDITIONS

- Ambient temperature: $-15^{\circ}\text{C} < \theta < 40^{\circ}\text{C}$ Altitude: not exceed 1000m
- Rated voltage: $380(1 \pm 5\%)\text{V}$

Model	Speed (r/min)	Output (kW)	Current (A)	Eff (%)	Power Fator	Ist/In	Tstar/Tn	Tmax/Tn
YD132M	8	720	3	9	78	0.65	5.5	1.5
YD160M	4	1440	4.5	9.4	82	0.88	6.5	1.5
YD160L	8	730	5	13.9	83	0.66	5.5	1.5
YD180L	4	1450	7.5	15.2	84	0.89	6.5	1.5
YD200L1	8	730	7	19	85	0.66	5.5	1.5
YD200L2	4	1450	11	21.8	86	0.89	6.5	1.5
YD225M	8	730	11	26	86	0.74	6	1.5
YD250M	4	1470	17	31.5	87	0.92	7	1.5
YD280S	8	740	14	33	86	0.74	6	1.5
YD280M	4	1470	22	41.3	88	0.92	7	1.5
YD90S	8	740	17	40.1	87	0.74	6	1.5
YD90L	4	1470	16	48.8	88	0.92	7	1.5
YD90L	8	740	24	53.2	89	0.77	6	1.4
YD90L	4	1470	34	66.7	88	0.88	7	1.3
YD90L	8	740	30	64.9	90	0.78	6	1.4
YD90L	4	1480	42	78.8	89	0.91	7	1.3
YD90L	8	740	40	83.5	91	0.8	6	1.4
YD90L	4	1480	55	102	90	0.91	7	1.3
YD90L	8	740	47	96.9	91	0.81	6	1.4
YD90L	4	1480	67	122.9	90	0.92	7	1.3
YD90S	8	680	0.35	1.6	56	0.6	5	1.5
YD90S	6	930	0.45	1.4	70	0.72	6	1.5
YD90L	8	680	0.45	1.9	59	0.6	5	1.5
YD90L	6	930	0.65	1.9	71	0.73	6	1.5
YD100L	8	710	0.75	2.9	65	0.6	5	1.5
YD100L	6	950	1.1	3.1	75	0.73	6	1.5
YD112M	8	710	1.3	4.5	72	0.61	5	1.5
YD112M	6	950	1.8	4.8	78	0.73	6	1.5
YD132S	8	730	1.8	5.8	75	0.62	5	1.5
YD132M	6	970	2.4	6.2	80	0.73	6	1.5
YD132M	8	730	2.6	8.2	78	0.62	5	1.5
YD160M	6	970	3.7	9.4	82	0.73	6	1.5
YD160M	8	930	4.5	13.3	83	0.62	5	1.5
YD160L	6	980	6	14.7	85	0.73	6	1.5
YD160L	8	930	6	17.5	84	0.62	5	1.5
YD180M	6	980	8	19.4	86	0.73	6	1.5
YD180M	8	930	7.5	21.9	84	0.62	5	1.5
YD180L	6	980	10	24.2	86	0.73	6	1.5
YD180L	8	730	9	24.8	85	0.65	5	1.5
YD200L1	6	980	12	28.3	86	0.75	6	1.5
YD200L1	8	730	12	32.5	86	0.65	5	1.5
YD200L2	6	980	17	39.1	87	0.76	6	1.5
YD200L2	8	730	15	40.3	87	0.65	5	1.5
YD100L	6/4/2	940/1420/2880	0.75/1.3/1.8	2.62/3.66/4.53	67/72/71	0.65/0.75/0.85	5.5/6/7	1.8/1.6/1.6
YD112M	6/4/2	940/1440/2890	1.1/2/2.4	3.52/5.14/5.80	73/74/74	0.65/0.81/0.85	5.5/6/7	1.7/1.4/1.6
YD132S	6/4/2	940/1440/2900	1.8/2/6.3	5.14/6.10/7.38	75/78/71	0.71/0.83/0.87	5.5/6/7	1.4/1.3/1.7
YD132M1	6/4/2	940/1440/2900	2.2/3.3/4	6.03/7.46/8.79	77/80/76	0.72/0.84/0.91	5.5/6/7	1.3/1.3/1.7
YD132M2	6/4/2	940/1440/2900	2.6/4/5	6.86/9.04/10.8	80/80/77	0.72/0.84/0.91	5.5/6/7	1.5/1.4/1.7
YD160M	6/4/2	970/1490/2930	3.7/5/6	9.52/11.2/13.2	81/81/76	0.72/0.84/0.91	5.5/6/7	1.5/1.3/1.4
YD160L	6/4/2	910/1460/2930	4.5/7/9	11.4/15.1/18.8	83/83/79	0.72/0.84/0.91	5.5/6/7	1.5/1.2/1.3
YD112M	8/4/2	710/1440/2900	0.65/2/2.4	2.66/5.14/5.80	59/74/74	0.63/0.81/0.85	4.5/6/7	1.4/1.3/1.2
YD132S	8/4/2	710/1440/2900	1/2.6/3	3.16/6.10/7.08	69/78/74	0.61/0.83/0.87	4.5/6/7	1.4/1.2/1.4
YD132M	8/4/2	710/1440/2900	1.3/3.7/4.5	4.56/8.37/10.0	71/80/75	0.61/0.84/0.91	4.5/6/7	1.5/1.3/1.4
YD160M	8/4/2	720/1460/2930	2.2/5/6	7.55/11.2/13.2	75/81/76	0.59/0.84/0.91	4.5/6/7	1.4/1.3/1.4
YD160L	8/4/2	720/1460/2930	2.8/7/9	9.21/15.10/18.80	77/83/79	0.60/0.85/0.92	5.5/6/7	1.3/1.2/1.3
YD112M	8/6/4	710/940/1400	0.85/1/1.5	3.72/3.06/3.53	62/68/75	0.56/0.73/0.86	5.5/6.5/7	1.4/1.2/1.4
YD132S	8/6/4	710/940/1440	1.1/1.5/1.8	4.10/4.22/4.03	68/74/78	0.60/0.73/0.87	5.5/6.5/7	1.4/1.3/1.3
YD132M1	8/6/4	710/940/1440	1.5/2/2.2	5.18/5.14/4.87	71/77/79	0.62/0.73/0.87	5.5/6.5/7	1.3/1.5/1.4
YD132M2	8/6/4	710/940/1440	1.8/2/6.3	6.13/6.84/6.55	72/78/80	0.62/0.74/0.87	5.5/6.5/7	1.5/1.5/1.5
YD160M	8/6/4	720/970/1460	3.3/4/5.5	10.2/9.87/11.6	79/81/83	0.62/0.76/0.87	5.5/6.5/7	1.7/1.4/1.5
YD160L	8/6/4	720/970/1460	4.5/6/7.5	13.8/14.5/15.6	80/83/84	0.62/0.76/0.87	5.5/6.5/7	1.6/1.6/1.5

Model	Speed (r/min)	Output (kW)	Current (A)	Eff (%)	Power Fator	Ist/In	Tstar/Tn	Tmax/Tn
YD801	4	1420	0.45	1.4	66	0.74	6.5	1.5
YD801	2	2860	0.55	1.5	65	0.85	7	1.6
YD802	4	1420	0.55	1.7	68	0.74	6.5	1.5
YD802	2	2860	0.75	2	66	0.85	7	1.6
YD90S	4	1430	0.85	2.3	74	0.77	6.5	1.5
YD90S	2	2850	1.1	2.8	73	0.84	7	1.6
YD90L	4	1430	1.3	3.3	76	0.78	6.5	1.5
YD90L	2	2850	1.8	4.3	74	0.84	7	1.6
YD100L1	4	1430	2	4.8	78	0.81	6.5	1.5
YD100L1	2	2850	2.4	5.6	76	0.86	7	1.6
YD100L2	4	1430	2.4	5.6	79	0.83	6.5	1.5
YD100L2	2	2850	3	6.7	77	0.89	7	1.6
YD112M	4	1450	3.3	7.4	81	0.83	6.5	1.5
YD112M	2	2860	4	8.6	80	0.88	7	1.6
YD132S	4	1450	4.5	9.8	83	0.85	6.5	1.5
YD132S	2	2860	5.5	11.9	79	0.89	7	1.6
YD132M	4	1450	6.5	13.8	84	0.85	6.5	1.5
YD132M	2	2880	8	17.1	80	0.89	7	1.6
YD160M	4	1460	9	18.5	87	0.86	6.5	1.5
YD160M	2	2920	11	22.9	82	0.9	7	1.6
YD160L	4	1460	11	22.3	87	0.87	6.5	1.5
YD160L	2	2920	14	28.8	82	0.9	7	1.6
YD180M	4	1470	15	29.4	89	0.88	6.5	1.5
YD180M	2	2940	18.5	36.7	85	0.91	7	1.6
YD180L	4	1470	18.5	35.9	89	0.89	6.5	1.5
YD180L	2	2940	22	42.7	86	0.92	7	1.6
YD200L	4	1470	26	49.9	89	0.89	6.5	1.4
YD200L	2	2950	30	58.3	85	0.92	7	1.4
YD225S	4	1480	32	60.7	90	0.89	6.5	1.4
YD225S	2	2960	37	71.7	86	0.92	7	1.4
YD225M	4	1480	37	69.4	91	0.9	6.5	1.4
YD225M	2	2960	45	86.4	87	0.92	7	1.4
YD250M	4	1480	45	84.4	91	0.9	6.5	1.4
YD250M	2	2960	55	103.2	88	0.93	7	1.4
YD280S	4	1480	60	111.3	91	0.7	6.5	1.4
YD280S	2	2970	72	135.1	88	0.79	7	1.4
YD280M	4	1480	72	133.6	91	0.7	6.5	1.4
YD280M	2	2970	82	152.2	88	0.79	7	1.4
YD90S	6	920	0.65	2.2	64	0.7	6	1.4
YD90S	4	1420	0.85	2.3	70	0.8	6.5	1.3
YD90L	6	930	0.85	2.8	66	0.7	6	1.4
YD90L	4	1420	1.1	3	71	0.8	6.5	1.3
YD100L1	6	940	1.3	3.8	74	0.75	6	1.4
YD100L1	4	1440	1.8	4.4	77	0.82	6.5	1.3
YD100L2	6	940	1.5	4.3	75	0.7	6	1.4
YD100L2	4	1440	2.2	5.4	77	0.82	6.5	1.4
YD112M	6	960	2.2	5.7	77	0.76	6	1.4
YD112M	4	1440	2.8	6.7	77	0.85	6.5	1.3
YD132S	6	960	3	7.7	79	0.78	6	1.4
YD132S	4	1440	4	9.5	80	0.85	6.5	1.3
YD132M	6	960	4	9.8	81	0.78	6	1.4
YD132M	4	1440	5.5	12.3	80	0.85	6.5	1.3
YD160M	6	970	6.5	15.1	84	0.78	6	1.3
YD160M	4	1460	8	17.4	83	0.85	6.5	1.4
YD160L	6	970	9	20.6	85	0.78	6	1.3
YD160L	4	1460	11	23.4	84	0.85	6.5	1.4
YD180M	6	980	11	25.9	85	0.78	6	1.3
YD180M	4	1470	14	29.8	85	0.85	6.5	1.3
YD180L	6	980	13	29.4	86	0.78	6	1.4
YD180L	4	1470	16	33.6	85	0.85	6.5	1.3
YD200L	6	980	18.5	41.4	87	0.78	6	1.4
YD200L	4	1460	22	44.7	87	0.86	6.5	1.3
YD225S	6	980	22	44.2	88	0.86	6.5	1.3
YD225S	4	1470	28	56.2	87	0.87	7	1.4
YD225M	6	980	26	52.2	88	0.86	6.5	1.3
YD250M	4	1470	34	66	87	0.9	7	1.4
YD250M	6	980	32	62.1	90	0.87	6.5	1.3
YD280S	4	1470	42	74.7	88	0.91	7	1.3
YD280S	6	980	42	81.5	90	0.87	6.5	1.4
YD280M	4	1470	55	104.2	89	0.9	7	1.3
YD280M	6	990	55	106.7	90	0.87	6.5	1.4
YD90L	8	680	0.45	1.9	58	0.63	6.5	1.5
YD90L	4	1420	0.75	1.92	65	0.87	6.5	1.5
YD100L	8	700	0.85					

YB

SERIES FLAMEPROOF ELECTRIC MOTORS

YB series flameproof three-phase induction electric motors have such characteristics as high efficiency, low noise, slight vibration, high locked-rotor torque and reliable operation. The rated voltage of YB series electric motor is 220V, 380V, 660V, 220/380V or 380/660V. The rated frequency of this series electric motor is 50Hz or 60Hz. The power grade and mounting dimensions of this series electric motors are the same as those of Y series electric motors, up to the IEC standard. The degree of protection by enclosure of YB series electric motors is IP44 and cooling form IC0141. Class F insulation is adopted. This series electric motor can operate constantly at environmental temperature of not higher than 40 C. The electric property index of YB series electric motors are the same as that of Y series electric motors.

FEATURE

- Frame size of YB series electric motor: H80-280mm.
- Power range of YB series electric motor: 0.55-90KW.
- Synchronous speed of YB series electric motor: 3000, 1500, 750r/min.
- Explosion protection marking of YB series electric motor: d I, d II AT4, d II Bt4.

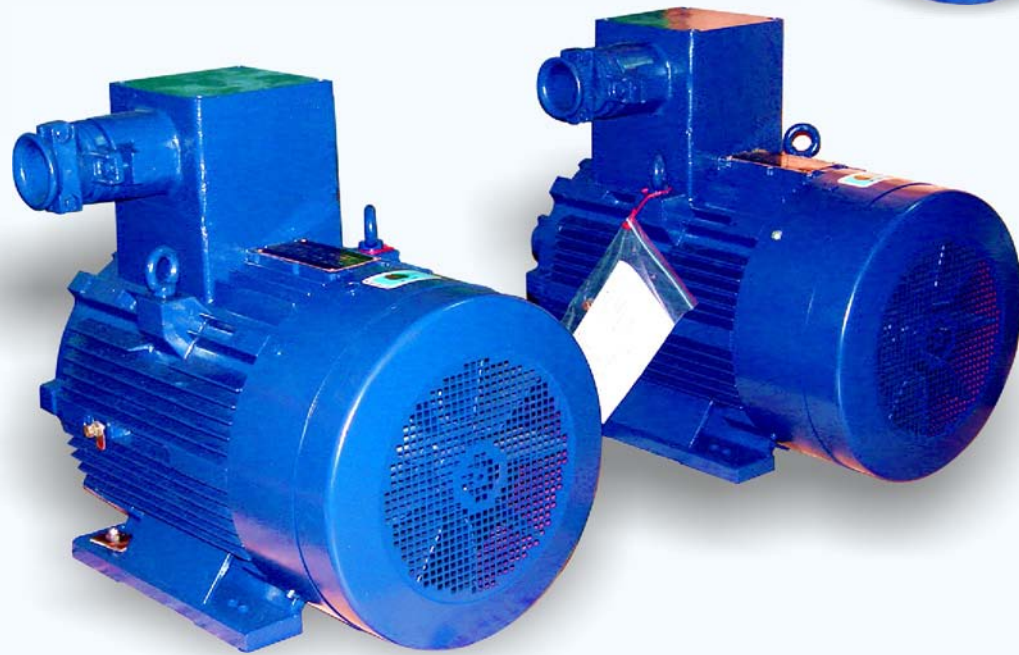
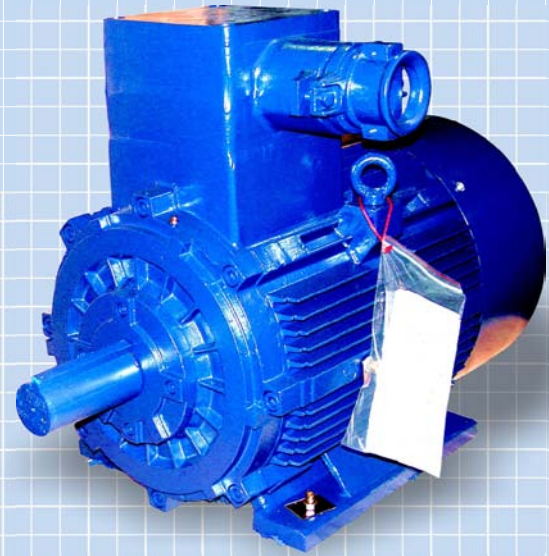

YC

HEAVY DUTY SERIES SINGLE-PHASE CAPACITOR START ASYNCHRONOUS MOTOR

These Single-Phase Heavy-Duty Capacitor Start Motors are made to IEC Standards. These are superior motors delivering excellent torque enabling the toughest jobs to be handled with dependable ease. They perform well in high voltage fluctuating regions and are commonly used in the pumping, compressor, agriculture, farming, building service and manufacturing industry.

MOTOR FEATURES

- IP44 Enclosure
- Class B Insulation, Class F available on request
- Low operating temperature
- Continuous S1 operation
- Industrial type service factors
- Cool running motors

CUSTOMER BENEFITS

- Water dust and vermin resistant
- Quiet operation
- Corrosion resistant
- Reliable in country, city or factory environments
- Suitable for hot environments
- Low start current and EMC interference

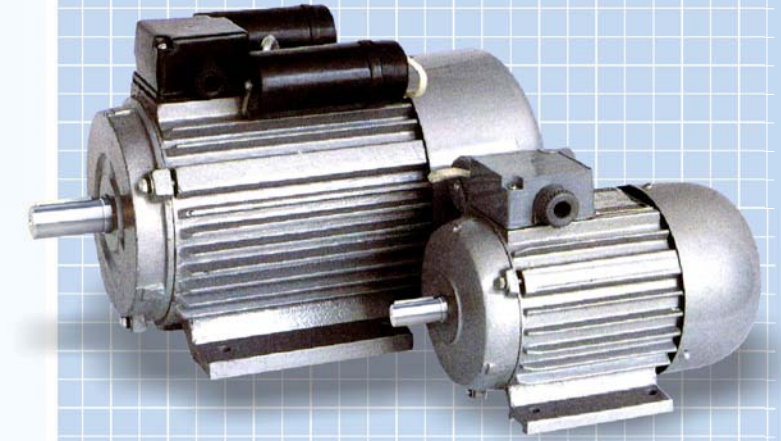

TECHNICAL DATA

Model	Rated Output		RPM	Full Load		
	KW	HP		Current 220V (A)	Eff. (%)	Power factor (cosE)
YC7112	0.18	1/4	2800	1.9	60	0.72
YC7122	0.25	1/3	2800	2.4	64	0.74
YC8012	0.37	1/2	2800	3.4	65	0.77
YC8022	0.55	3/4	2800	4.7	68	0.79
YC90S-2	0.75	1	2800	6.1	70	0.80
YC90L1-2	1.1	1.5	2800	8.7	72	0.80
YC90L2-2	1.5	2	2800	11.4	74	0.81
YC100L2-2	2.2	3	2800	16.5	75	0.81
YC112M-2	3	4	2800	21.9	76	0.82
YC132S-2	3.7	5	2800	26.6	77	0.82
YC7124	0.18	1/4	1400	2.5	53	0.62
YC8014	0.25	1/3	1400	3.1	58	0.63
YC8024	0.37	1/2	1400	4.2	62	0.64
YC90S-4	0.55	3/4	1400	5.5	66	0.69
YC90L1-4	0.75	1	1400	6.9	68	0.73
YC90L2-4	1.1	1.5	1400	9.5	71	0.74
YC100L2-4	1.5	2	1400	12.5	73	0.75
YC112M-4	2.2	3	1400	17.8	74	0.76
YC132S-4	3	4	1400	23.6	75	0.77
YC132M-4	3.7	5	1400	28	76	0.79

YL

SERIES SINGLE-PHASE DUAL-CAPACITOR ASYNCHRONOUS MOTOR

These single-phase dual capacitor motors are made to IEC standards. These are superior motors delivering excellent torque enabling the toughest jobs to be handled with dependable ease. They perform well in high voltage fluctuating regions and are commonly used in the pumping, compressor, agriculture, farming, building service and manufacturing industry.



MOTOR FEATURES

- IP44 enclosure
- Class B insulation, Class F available on request
- Low operating temperature
- High quality magnet wire
- Vacuum varnish impregnation for superior tropic proof insulation
- Continuous S1 operation
- Industrial type service factors
- Heavy duty ball bearings
- Balanced rotors

CUSTOMER BENEFITS

- Water dust and vermin resistant
- Quiet operation
- Corrosion resistant
- Reliable in country, city or factory environments
- Low vibration
- Low power consumption
- Superior life
- High strength cast iron frame

INSTALLATION DIMENSIONS

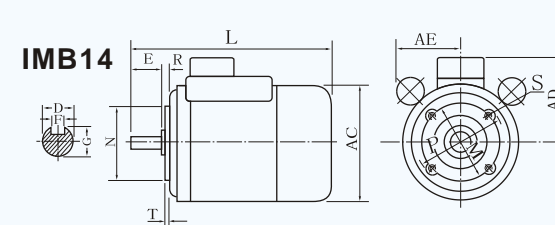
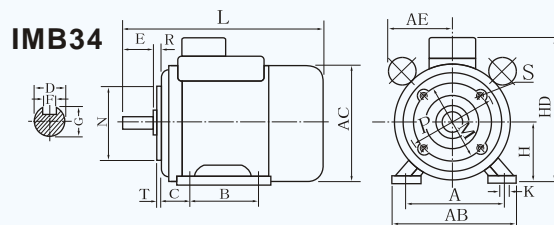
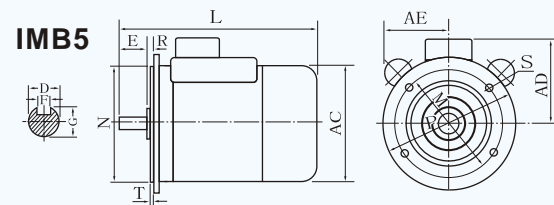
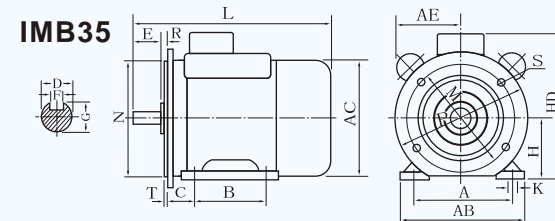
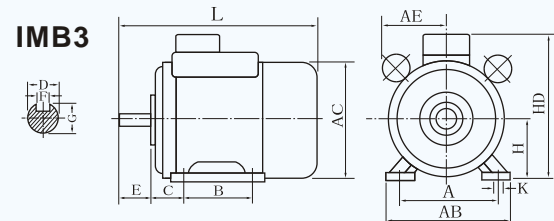

TECHNICAL DATA

Model	Power		Volt (V)	Current (A)	Speed (r.p.m.)	Eff. (%)	Power factor	Starting Torque Rated Torque	Starting Current (A)	Max Torque Rated torque	Weight (kg)
	HP	kW									
YL711-2	1/2	0.37	220	2.73	2800	67	0.92	1.8	16	1.8	8
YL712-2	3/4	0.55	220	3.88	2800	70	0.92	1.8	21	1.8	9
YL801-2	1	0.75	220	5.15	2800	72	0.92	1.8	29	1.8	11
YL802-2	1.5	1.1	220	7.02	2800	75	0.95	1.8	40	1.8	12
YL90S-2	2	1.5	220	9.44	2820	76	0.95	1.7	55	1.8	13
YL90L-2	3	2.2	220	13.7	2820	77	0.95	1.7	80	1.8	17
YL711-4	1/3	0.25	220	1.99	1400	62	0.92	1.8	12	1.8	8
YL712-4	1/2	0.37	220	2.81	1400	65	0.92	1.8	16	1.8	9
YL801-4	3/4	0.55	220	4.0	1400	68	0.92	1.8	21	1.8	11
YL802-4	1	0.75	220	5.22	1400	71	0.92	1.8	29	1.8	12
YL90S-4	1.5	1.1	220	7.21	1420	73	0.95	1.7	40	1.8	13
YL90L-4	2	1.5	220	9.57	1420	75	0.95	1.7	55	1.8	17
YL100L1-4	3	2.2	220	13.9	1420	76	0.95	1.7	80	1.8	26
YL100L2-4	4	3	220	18.6	1420	77	0.95	1.7	110	1.8	28
YL112M-4	3	2.2	220	13.9	1440	76	0.95	1.7	80	1.8	31
YL112M1-4	4	3	220	18.6	1440	77	0.95	1.7	110	1.8	34
YL112M2-4	5	3.7	220	23	1440	78	0.95	1.7	138	1.8	38
YL132SA-4	4	3	220	18.6	1440	77	0.95	1.7	110	1.8	55
YL132SB-4	5	3.7	220	23	1440	78	0.95	1.7	138	1.8	60

Frame Size	Mounting Dimensions (mm)																				Frame Dimensions (mm)						
	IMB3										IMB14		IMB34		IMB5		IMB35		AB	AC	AD	AE	HD	L			
	A	B	C	D	E	F	G	H	K	M	N	P	R	S	T	M	N	P							R	S	T
71	112	90	45	14	30	5	11	71	7	85	70	105	0	M6	2.5	-	-	-	-	-	-	145	145	140	105	180	255
80	125	100	50	19	40	6	15.5	80	10	100	80	120	0	M6	2.5	-	-	-	-	-	-	160	165	150	120	200	295
90S	140	100	56	24	50	8	20	90	10	115	95	140	0	M8	3	-	-	-	-	-	-	180	185	160	130	240	370
90L	140	125	56	24	50	8	20	90	10	115	95	140	0	M8	3	-	-	-	-	-	-	180	185	160	130	240	400
100L	160	140	63	28	60	8	24	100	12	-	-	-	-	-	215	180	250	0	15	4	205	220	180	130	260	430	
112M	190	140	70	28	60	8	24	112	12	-	-	-	-	-	215	180	250	0	15	4	245	250	190	140	300	455	
132S	216	140	89	38	80	10	33	132	12	-	-	-	-	-	265	230	300	0	15	4	280	290	210	155	350	525	

JY



SERIES SINGLE-PHASE CAPACITOR START ASYNCHRONOUS MOTOR

These single-phase capacitor start motors are made to IEC standards. These are superior motors delivering excellent torque while keeping the starting current low enabling them to be used where the power supply is limited. They are commonly used in the pumping, compressor, agriculture, farming, building service and the manufacturing industry.

MOTOR FEATURES

- IP44 enclosure
- Class B insulation, Class F available on request
- Low operating temperature
- High quality magnet wire
- Vacuum varnish impregnation for superior tropic proof insulation
- Continuous S1 operation
- Industrial type service factors
- Heavy duty ball bearings
- Balanced rotors
- Low start current
- Can be made with cast iron or aluminium motor body

CUSTOMER BENEFITS

- Water dust and vermin resistant
- Quiet operation
- Corrosion resistant
- Reliable in country, city or factory environments
- Low vibration
- Low power consumption
- Superior life
- High strength frame
- Starts in low voltage areas

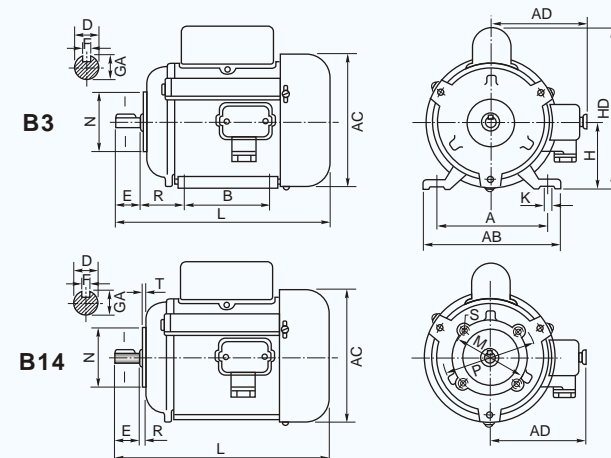

INSTALLATION DIMENSIONS

TECHNICAL DATA

Frame Size	Model	Output		Speed (r.p.m.)	Power Factor	Eff (%)	Max torque Rated torque	Starting torque Rated torque	Weight (kg)
		W	HP						
09	JY09A-2	250	1/3	2800	0.72	63	1.8-2	2-3.5	21.7
	JY09B-2	180	1/4	2800	0.72	60	1.8-2	2-3.5	21.7
	JY09A-4	180	1/4	1400	0.62	56	1.8-2	2-3.5	20
1	JY1A-2	550	3/4	2800	0.72	66	1.8-2	2-3.5	14
	JY1B-2	370	1/2	2800	0.72	66	1.8-2	2-3.5	14
	JY1A-4	370	1/2	1400	0.62	64	1.8-2	2-3.5	13
	JY1B-4	250	1/3	1400	0.62	60	1.8-2	2-3.5	23
2	JY2A-2	1100	1.5	2850	0.77	71	1.8-2	2-3.5	11.5
	JY2B-2	750	1	2850	0.75	70	1.8-2	2-3.5	10.2
	JY2A-4	750	1	1400	0.68	69	1.8-2	2-3.5	10.2
	JY2B-4	550	3/4	1400	0.68	67	1.8-2	2-3.5	16

Note: The motor is designed according to power supplies 220V/110V,50Hz, Special design may be accommodated with the customers, particular requirements as 230V,50Hz or 220V/110V,60Hz,etc.

INSTALLATION DIMENSIONS

Frame Size	Mounting Dimensions (mm)														Frame Dimensions (mm)					
	A	B	C	D	E	F	GA	H	K	M	N	P	R	S	T	AB	AC	AD	HD	L
09	125	100	50	14	30	4	15.5	80	10	85	70	105	0	M6	3	156	156	108	190	258
1	140	100	56	16	40	5	18	90	10	100	80	120	0	M8	3	176	176	121	220	286
2	160	112	63	19	40	6	21.5	100	12	115	95	140	0	M8	3	190	190	128	246	330

YU SERIES SINGLE-PHASE RESISTANCE START DOUBLE-SPEED, STEEL HOUSING MOTOR

This motor is with double speed (4/6Pole), without capacitor and with special type of centrifugal switch. Starting performance is acted between capacitor start and capacitor running type motor. It is designed for driving fan, cooling system, water pumps etc, which need speed to be adjusted. It has good features of low noise, low vibration

Model	YU90-4/6-1/4	YU90-4/6-1/3	YU90-4/6-1/2
Power (W)	180/60	250/80	370/120
Current (A)	2.6 / 1.9	3.0 / 2.1	3.7 / 2.8
Speed (RPM)	1425/925	1425/925	1425/925
T start / T n	0.9 / 2.0	0.9 / 2.0	0.9 / 2.0
T max. / T n	1.5 / 1.8	1.5 / 1.8	1.5 / 1.8
I st (A)	13.0	13.0	16.5
Insulation	B	B	B
Rot. Direction	CW	CW	CW

YU



CR SERIES STEEL CASING MOTOR FOR COOLANT PUMP

Main features

- Compact design
- Low noise
- Low vibration
- Self-lubrication bushing bearing system
- Different voltage & Frequency available

Model	CR-7	CR-9	CR-11	CR-18	CR-25
Voltage (V)	127 / 220	127 / 220	127 / 220	127 / 220	127 / 220
Frequency (Hz)	60 / 50	60 / 50	60 / 50	60 / 50	60 / 50
Speed (RPM)	2400/3000	2400/3000	2400/3000	2400/3000	2400/3000
Rot. Direction	CW/CCW	CW/CCW	CW/CCW	CW/CCW	CW/CCW
Insulation	B	B	B	B	B
Duty	S1	S1	S1	S1	S1
Lift Head (m)	2	2	2	2	2

CR



YTF

SERIES INDUCTION MOTOR FOR FAN

YTF Series motor is a new kind patent electrical motor,As its salient poles are hided in its stator,this motor presents very soft operation characteristic and easy for speed control,This series motor is very economy,safety and credibility running,no pollution for environment in electro-magnetic interference and noise,It is a ideal driving motor for electrical appliance for domestic use.

FEATURE

- Higher power factor up to 0.92-0.98%.
- More efficient 5-10% higher than common capacitor starting motor.
- With simple and reasonable construction and smaller its occupant,it is with very high reliably and easy to use,economic and pragmatic.
- Using powder-brass oil-retaining bearing and excellence against wearing, it has a very long-life (more than 15000 hours),operating at lower noise of about 30db,without Electro-magnetic interference.
- Insulation: class B,small starting current which only 1.1 times of its rated current,and lower rocked current of 1.1-1.2 time its rated current,So this motor can stay safe on operating.
- Easy for speed control by changing different capacitor,save energy greatly for fan and small pump using.

INSTALLATION DIMENSIONS

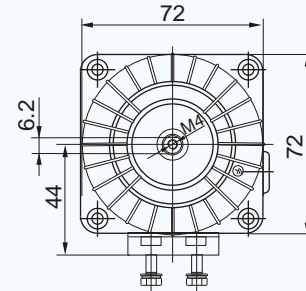
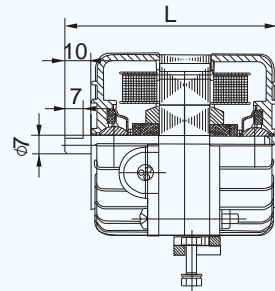
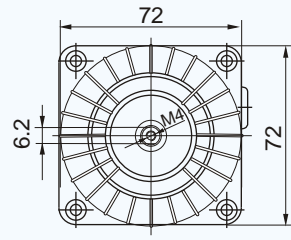
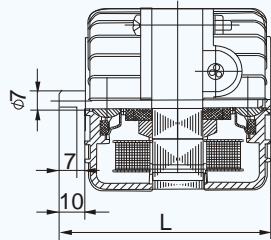

TYPE	Input	Rated Voltage(V)	Rated Current(A)	Power Factor	Frequency(Hz)	Speed(r/min)	Starting Current	Stall Current	Noise(dB)
YTF-16	16	220V	0.08A	0.91	50Hz	700-2800	1.15-1.2	1.1-1.2	≤ 30
YTF-25	25	220V	0.12A	0.93	50Hz	700-2800	1.15-1.2	1.1-1.2	≤ 30
YTF-30	30	220V	0.15A	0.91	50Hz	700-2800	1.15-1.2	1.1-1.2	≤ 30
YTF-40	40	220V	0.20A	0.92	50Hz	700-2800	1.15-1.2	1.1-1.2	≤ 30
YTF-50	50	220V	0.24A	0.94	50Hz	700-2800	1.15-1.2	1.1-1.2	≤ 30
YTF-60	60	220V	0.30A	0.93	50Hz	700-2800	1.15-1.2	1.1-1.2	≤ 30
YTF-70	70	220V	0.34A	0.92	50Hz	700-2800	1.15-1.2	1.1-1.2	≤ 30
YTF-90	90	220V	0.44A	0.93	50Hz	700-2800	1.15-1.2	1.1-1.2	≤ 30
YTF-120	120	220V	0.59A	0.93	50Hz	700-2800	1.15-1.2	1.1-1.2	≤ 30
YTF-150	150	220V	0.47A	0.92	50Hz	700-2800	1.15-1.2	1.1-1.2	≤ 30
YTF-180	180	220V	0.89A	0.92	50Hz	700-2800	1.15-1.2	1.1-1.2	≤ 30
YTF-200	200	220V	0.98A	0.93	50Hz	700-2800	1.15-1.2	1.1-1.2	≤ 30
YTF-220	220	220V	1.06A	0.94	50Hz	700-2800	1.15-1.2	1.1-1.2	≤ 30
YTF-250	250	220V	1.20A	0.94	50Hz	700-2800	1.15-1.2	1.1-1.2	≤ 30
YTF-280	280	220V	1.37A	0.93	50Hz	700-2800	1.15-1.2	1.1-1.2	≤ 30
YTF-350	350	220V	1.73A	0.92	50Hz	700-2800	1.15-1.2	1.1-1.2	≤ 30

SINGLE-PHASE / THREE PHASE AC ALTERNATOR



ALTERNATOR

ST



SERIES SINGLE-PHASE A.C. SYNCHRONOUS GENERATOR

ST series generators are mainly designed to serve as power generating unit for lighting purpose in ships, towns or villages and house-hold electric appliances. The construction of the generators is drip-proof type, IP21, salient-pole rotating field self excitation and constant voltage type. The generator interior is made of high quality magnetic and electrical materials. Insulation for stator and rotor is class B or F.

The generators are elegant in appearance, tight in construction and easy maintenance. IEC standard are adopted on dimension, which are suitable for using in Australia, Europe, America and other countries with the end covers to be model B. The generators are made as per standard JB/T3320.2-2000. And in conformity to IEC34-1.

ENVIRONMENT CONDITIONS

Under the following environment, the generator could run continuously:

- Altitude: not exceed 1000m.
- Cooling air temperature: 25~313K (-15°C~40°C).
- Relative air humidity: not exceed 90%.

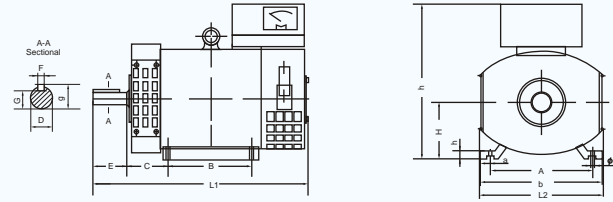

INSTALLATION DIMENSIONS

Type	Output(kw)	Current(A)		Voltage(V)		Power Factor(cos)	Pole Numbei	Speed (r.p.m)	Freq. (hz)
		Series Connection	Parallel Connection	Series Connection	Parallel Connection				
ST-1	1	4.35	8.7	230	115	1.0	4	1500/1800	50/60
ST-2	2	8.7	17.4	230	115	1.0	4	1500/1800	50/60
ST-3	3	13	26	230	115	1.0	4	1500/1800	50/60
ST-5	5	21.8	43.5	230	115	1.0	4	1500/1800	50/60
ST-7.5	7.5	32.6	65.2	230	115	1.0	4	1500/1800	50/60
ST-10	10	43.5	87	230	115	1.0	4	1500/1800	50/60
ST-12	12	52.2	104	230	115	1.0	4	1500/1800	50/60
ST-15	15	65.3	130	230	115	1.0	4	1500/1800	50/60
ST-20	20	87	174	230	115	1.0	4	1500/1800	50/60
ST-24	24	104	208	230	115	1.0	4	1500/1800	50/60

Type	Output (kw)	Installing Dimensions(mm)										Overall Dimensions(mm)					
		H	A	B	C	D	E	F	G	g	K	a	b	H1	h	L1	L2
ST-1	1	132	216	178	89	32	80	10	27	34.8	12	34	250	18	384	480	270
ST-2	2	132	216	178	89	32	80	10	27	34.8	12	34	250	18	385	480	270
ST-3	3	132	216	178	89	32	80	10	27	34.8	12	34	250	18	384	480	270
ST-5	5	160	254	254	108	38	80	10	33	40.8	15	50	310	25	440	580	325
ST-7.5	7.5	160	254	254	108	38	80	10	33	40.8	15	50	310	25	440	580	325
ST-10	10	180	279	203	121	42	110	12	37	44.8	15	60	339	25	480	610	365
ST-12	12	180	279	203	121	42	110	12	37	44.8	15	60	339	25	480	610	365
ST-15	15	200	318	228	133	48	110	14	42.5	51.2	19	60	378	30	540	660	400
ST-20	20	200	318	228	133	48	110	14	42.5	51.2	19	60	378	30	540	660	400
ST-24	24	200	318	228	133	48	110	14	42.5	51.2	19	60	378	30	540	660	400

STC

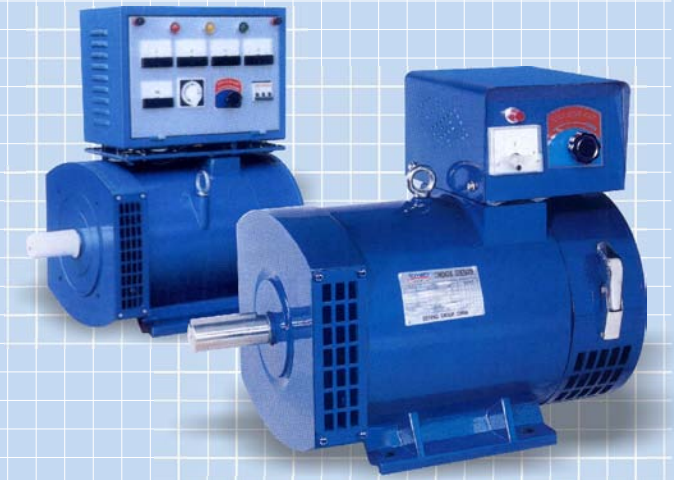

SERIES THREE-PHASE A.C. SYNCHRONOUS GENERATOR

STC series generators are used in town, countryside, worksites, villages and pastures as emergence power source. The generators are drip-proof with rotary field type, IP23, Insulation Class: B or F, adopting harmonic excitation system, safe and reliable using, easy operation and maintenance.

The generators are three-phase, four-wire type, adopting star connection with neutral point. The rated line voltage is 400V, phase voltage 230V, frequency 50Hz, power factor 0.8(lag). We can provide 60Hz and the other voltage's generator according to the customer's request.

They can be coupled with a prime mover directly or through v-belt making right or reverse continuous rotation at the rated speed. When the rotation speed of prime mover changes 3% or so and load varies in the range of 0-100% Cosφ 0.8-1.0, the generators offer constant voltage, when sudden change (increase or decrease) of load, the generator will soon return to their normal working state, at the same time, without any starting device the generator can directly start an unloaded squirrel cage induction motor. The generators are made as per standard JB/T8981-1999. And in conformity to IEC34-1.

ENVIRONMENT CONDITIONS

Under the following environment, the generator could run continuously:

- Altitude: not exceed 1000m.
- Cooling air temperature: 25~313K (-15°C~40°C).
- Relative air humidity: not exceed 90%.

INSTALLATION DIMENSIONS

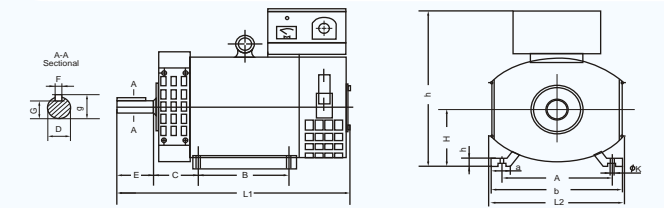

Type	Output		Voltage(V)	Current(A)	Power factor(cos)	Speed(r/min)	Freq.(Hz)	Pole Numbei
	KVA	KW						
STC-3	3.8	3	400/230	5.4	0.8	1500	50	4
STC-5	6.3	5	400/230	9	0.8	1500	50	4
STC-7.5	9.4	7.5	400/230	13.5	0.8	1500	50	4
STC-8	10	8	400/230	14.4	0.8	1500	50	4
STC-10	12.5	10	400/230	18.1	0.8	1500	50	4
STC-12	15	12	400/230	21.7	0.8	1500	50	4
STC-15	18.8	15	400/230	27.1	0.8	1500	50	4
STC-20	25	20	400/230	36.1	0.8	1500	50	4
STC-24	30	24	400/230	43.3	0.8	1500	50	4
STC-30	37.5	30	400/230	54.1	0.8	1500	50	4
STC-40	50	40	400/230	72.2	0.8	1500	50	4
STC-50	62.5	50	400/230	90.2	0.8	1500	50	4

Type	Output		Installing dimensions(mm)										Overall dimensions(mm)					
	kVA	kW	H	A	B	C	D	E	F	G	g	K	a	b	H1	h	L1	L2
STC-3	3.8	3	132	216	178	89	32	80	10	27	34.8	12	34	250	18	400	480	270
STC-5	6.3	5	160	254	254	108	38	80	10	33	40.8	15	50	310	25	455	580	325
STC-7.5	9.4	7.5	160	254	254	108	38	80	10	33	40.8	15	50	310	25	455	580	325
STC-8	10	8	160	254	254	108	38	80	10	33	40.8	15	50	310	25	455	580	325
STC-10	12.5	10	180	279	203	121	42	110	12	37	44.8	15	60	339	25	495	610	365
STC-12	15	12	180	279	203	121	42	110	12	37	44.8	15	60	339	25	495	610	365
STC-15	18.8	15	200	318	228	133	48	110	14	42.5	51.5	19	60	378	30	540	660	400
STC-20	25	20	200	318	228	133	48	110	14	42.5	51.5	19	60	378	30	540	660	400
STC-24	30	24	200	318	228	133	48	110	14	42.5	51.5	19	60	378	30	540	660	400
STC-30	37.5	30	225	356	286	149	60	140	18	53	64	19	65	421	32	610	770	452
STC-40	50	40	225	356	286	149	60	140	18	53	64	19	65	421	32	610	770	452
STC-50	62.5	50	225	356	311	149	60	140	18	53	64	19	65	421	32	610	810	452

TZH



SERIES THREE-PHASE COMPOUND EXCITATION A.C. SYNCHRONOUS GENERATOR

TZH series generators are made as per standard JB/T8981-1999. And in conformity to IEC34-1. Protection class: IP21, Insulation class B or F, The rotor structure is Concealed type, Performance is more reliable.

TZH series generators have five advantages comparing with STC series generators. Compound excitation, simple circuit, high reliability, easy maintenance. Excellent dynamic characteristics, when load or unload suddenly, the circuit's light will not twinkle. Strong starting system, even the motors only with its 70% capacity volume can be directly started and the switch will not trip.

Approaching sine voltage wave and regulated power supply, output voltage can be safely used on computers. The deviation of the 3-phase line voltage will be less than 3% when the generators undertake unbalanced loading.

ENVIRONMENT CONDITIONS

Under the following environment, the generator could running continuously:

- Altitude: not exceed 1000m.
- Cooling air temperature: 258-313K (-15C-40C).
- Relative air humidity: not exceed 90%.

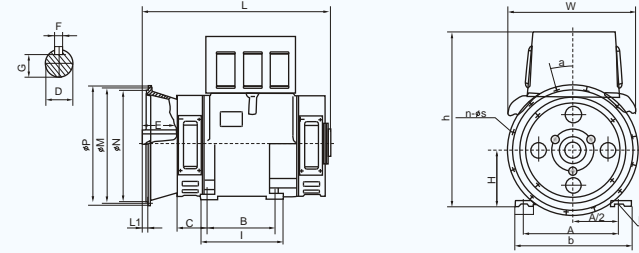

INSTALLATION DIMENSIONS

Type	Frame number	Rated power		Rated current(A)	Rated voltage(V)	Rated speed(r/min)	Freq.(Hz)	COS	Bearibg Type		Pole Eff(%)
		KW	KVA						DE	NDE	
TZH-30	225S	30	37.5	54.1	400/230	1500	50	0.8	2312	311	88.0
TZH-40	225M	40	50	72.2	400/230	1500	50	0.8	2312	311	89.0
TZH-50	225L	50	62.5	90.2	400/230	1500	50	0.8	2312	311	89.5
TZH-64	250M	64	80	115	400/230	1500	50	0.8	2315	313	90.5
TZH-75	250L	75	93.75	135	400/230	1500	50	0.8	2315	313	90.8
TZH-90	280S	90	112.5	162	400/230	1500	50	0.8	2317	316	91.0
TZH-120	280L	120	150	217	400/230	1500	50	0.8	2317	316	91.5
TZH-150	355S	150	187.5	271	400/230	1500	50	0.8	2319	318	92.0
TZH-200	355M	200	250	361	400/230	1500	50	0.8	2319	318	92.3
TZH-250	355L	250	312.5	451	400/230	1500	50	0.8	2319	318	92.5

Type	Mounting Dimensins(mm)													Overall Dimensions							
	H	A	A/2	B	C	D	E	F	G	K	N	M	a	n-s	P	L	I	L1	W	b	h
TZH-30	225	356	178	286	163	60	140	18	53	19	532	552	15	12-12	572	770	346	18	530	421	700
TZH-40	225	356	178	311	163	60	140	18	53	19	532	552	15	12-12	572	810	346	18	530	421	700
TZH-50	225	356	178	356	163	60	140	18	53	19	532	552	15	12-12	572	870	371	18	530	421	700
TZH-64	250	406	203	349	168	70	140	20	62.5	24	532	552	15	12-12	572	905	453	18	560	560	800
TZH-75	250	406	203	406	168	70	140	20	62.5	24	532	552	15	12-12	572	945	490	18	560	560	800
TZH-90	280	475	228.5	368	190	80	170	22	71	24	532	552	15	12-12	572	1040	438	18	640	580	885
TZH-120	280	475	228.5	457	190	80	170	22	71	24	532	552	15	12-12	572	1120	517	18	640	580	885
TZH-150	355	610	305	500	254	90	170	25	81	28	605	625	15	12-14	645	1270	585	22	860	720	1020
TZH-200	355	610	305	500	254	90	170	25	81	28	605	625	15	12-14	645	1270	585	22	860	720	1020
TZH-250	355	610	305	560	254	90	170	25	81	28	605	625	15	12-14	645	1385	645	22	860	720	1020

FD

FD SERIES SELF-EXCITED, SELF-REGULATING, BRUSHLESS GENERATOR

This new series of alternators is the result of our long experience in this sector and of diligent studies and researches aiming to keep pace with the technological development of an era where technology is the winning card.

The entire series is manufactured according to and complies with the most common specifications such as CEI 2-3, IEC 34-1, EN 60034-1, VDE 0530, BS 4999-5000, CAN/CSA-C22.2N 14-95; Special versions are available on request to meet specific specifications and regulations.

APPLICATIONS

The new FD series has been designed to meet both the traditional requirements of the industry and the more technological requirements of applications such as telecommunications, co-generation, army, aeronautics and marine sectors

RANGE

The FD generators are available with 50/60Hz frequency, with 4poles ranging from 8.1 to 1200KVA with single or double supports.

In order to couple them with the prime mover it is possible to choose among a wide range of flanges and couplings.

STANDARD FEATURE















- Advanced Designed / Reliable Quality / High Configuration Parts Adopted
- Cooperation with American Basler, the leader in electrical excitation system field.
- Install with original American Basler AVC63 series AVR
- Adopted high-efficient single-direction rotated fan
- Single or double bearings are available, options for all kinds of adaptors and disc plates
- Standard "H" Class Insulation
- convenient installation and maintenance for lead-end rotated bodies and adaptor connected bolts
- With full sealed free-maintenance bearing
- Auxiliary winding in excitation system as option
- Conform with BS5000, IEC34, VDE050, CSAC22.2-100 Standard

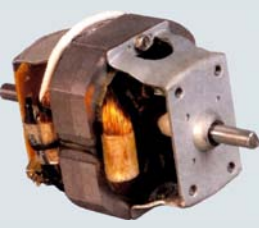

Model	Rrime power	
	KVA	KW
FD1A	8.1	6.5KW
FD1B	11.0	8.8KW
FD1C	13.5	10.8KW
FD1D	16.0	12.8KW
FD1E	22.5	18KW
FD1F	27.5	22KW
FD1G	31.3	25KW
FD2A	37.5	30KW
FD2B	50.0	40KW
FD2C	62.5	50KW
FD2D	87.5	70KW
FD3A	100.0	80KW
FD3B	112.5	90KW
FD3C	125.0	100KW
FD3D	150.0	120KW
FD3E	187.5	150KW
FD3F	200.0	160KW
FD4S	250.0	200KW

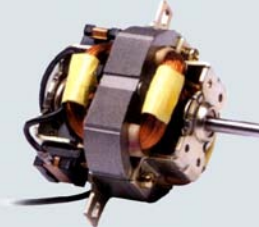
Model	Rrime power	
	KVA	KW
FDMS	293.8	235KW
FD4M	312.5	250KW
FD4LS	343.8	275KW
FD4L	375.0	300KW
FD5S	450.0	360KW
FD5M	500.0	400KW
FD5L	625.0	500KW
FD6A	800.0	640KW
FD6B	912.5	730KW
FD6C	1025.0	820KW
FD6D	1137.5	910KW

MICRO MOTOR

YJ58 Series AC Shaded Pole Motor	YJ58 Series AC Shaded Pole Motor	YJ61 Series AC Shaded Pole Motor	YJ62 Series AC Shaded Pole Motor
			
Exhaust-fan,Fan-heater.	Exhaust-fan,Fan-heater.	Microwave Oven,Fan-heater.	Microwave Oven,Fan-heater.
YJ58 Series AC Shaded Pole Motor	YJ82 Series AC Shaded Pole Motor	YJ48 Series AC Shaded Pole Motor	YJ48 Series AC Shaded Pole Motor
			
Sterilizing Cupboard.	Refrigerator,Exhaust-fan.	Water pump motor specially for air-conditioner.	Humidifier,Dishwasher,Air-conditioner,Fan-heater.
HC88 Series AC Universal Motor	HC88 Series AC Universal Motor	HC55 Series AC Universal Motor	HC70 Series AC Universal Motor
			
Lawn mower,edge trimmer,blower.	Lawn mower,edge trimmer,blower.	Edge trimmer,grass trimmer.	Polisher,Mixer,Juicer and vacuum cleaner.
HC55 Series AC Universal Motor	HC55 Series AC Universal Motor	HC66 Series AC Vacuum Cleaner Motor	HC82 Series AC Vacuum Cleaner Motor
			
Hair dryer,Polisher,Mixer,Juicer, Vacuum cleaner,Food processor.	Hair dryer,Polisher,Mixer,Juicer, Vacuum cleaner,Food processor.	Vacuum cleaner	Vacuum cleaner

MOTOR SELECTION

To determine the type of motor suitable for any particular single-phase application, it is necessary to know the advantages and disadvantages of each type. Some typical applications and reasons for using a particular type are given below.

Duty	Motor	Reason
Compressor	Cap Start	— High Starting torque
High Inertia Blower	Cap. St. & Run	— Low run-up period
Centrifugal Pumps	Split Phase	— Low starting torque
	Cap. St. & Run	— acceptable & in low HP, shaded pole may be satisfactory. Split-phase is normal. Cap st. Run may be used where stg. Is critical. Use Cap. St. & run if there are objections to C.F. gear. Necessary above 370 watt Advantage of lower starting currents than split-phase.
Fan	Shaded Pole	— The remarks above against Centrifugal Pumps apply equally to fans.
Centrifugal or Axial	Split-Phase	
Fans	Cap. St. & Run	— See paragraph on Speed Variation.
Variable Speed	Cap. St. & Run	— Generally acceptable.
Geared Units	Split-Phase	— Necessary above 370 watts.
	Cap Start	— Normally acceptable but high torque or special characteristics sometimes necessary.
Washing Machines	Split-Phase	— Usual on automatics.
	Cap. Start	— Normally acceptable up to 370 watts. Capacitor Start above 370 watts.
Oil Burners	Split-Phase	
Office Machinery	Split Phase	

ENCLOSURES I.P. NUMBERS

Designation	1st Numeral	2st Numeral	General Description
	Protection against contact and against ingress of foreign bodies	Protection against water	
I.P.21	Protection against contact by finger with electrically live or moving parts inside the enclosure. Protection against ingress of solid foreign bodies with a diameter greater than 12 mm	Dripping water falling vertically	Drip proof
I.P.22		Dripping water falling at an angle up to 15° from the vertical	Drip proof
I.P.23		Water falling as spray at an angle up to 60° from the vertical	Drip proof
I.P.44	Protection against contact with live or moving parts by tools, wires or other objects of thickness greater than 1 mm. Protection against the ingress of solid foreign bodies with a diameter greater than 1 mm	Water splashed against the machine from any direction shall have no harmful effect	T.E.F.V. or T.E.N.V.
I.P.55	Complete protection against contact with live or moving parts. Protection against harmful deposits of dust. The ingress of dust is not totally prevented, but does not accumulate in an amount sufficient to impair operation of the machine	Water projected by a nozzle against the machine from any direction shall have no harmful effect	T.E.F.V. or T.E.N.V. Weatherproof or Dustproof or Hoseproof
I.P.56		Machine protected against conditions on a ship's deck	T.E.N.V. Deck Watertight

TROUBLE SHOOTING

SYMPTOMS YOU CAN SEE		
Symptom	Possible Causes	Cure
1 Motor won't start	Usually power trouble-single-phasing at starter perhaps a fuse blown.	Check source of power supply DON'T merely try to make it go, while motor sits there and "fries" .
	Load too heavy. Disconnect motor to see if it starts without load.	Reduce load-or replace with motor of greater horse power.
SYMPTOMS YOU CAN HEAR		
2 Excessive hum	Uneven air-gap. Measure with feelers.	Replace bearings-before introduction of scraping noise indicates rotor is rubbing against stator.
	Winding fault, short circuit.	Check, and repair if necessary by electrical rewinder.
	Unbalanced rotor.	Re-balance rotor-dynamically if possible.
3 Regular clicking	Foreign matter in air gap.	Take out rotor, remove matter.
4 Rapid knocking (Oil bearings)	Misalignment - probably causing shoulder of shaft to pound periodically against bearing end. Worn bearing.	Re-align and re-level set until knocking disappears. Fit new bearing.
5 Knocking Rumbling (Ball bearings)	Bearing worn due to lack of lubrication or excessive mechanical overload.	Replace bearings and put in new grease of recommended grade.
	Severe thrust.	(as above).
	Double location if two ball bearings are fitted.	Check cap spigots and reduce at one end if necessary, so that only one bearing is located to take end thrust.
	Bearings slack in housings.	Fit new end-shield.
	Bearing moving on shaft.	Change bearing for one with tighter bore.
	Foreign matter in grease or bearing housing.	Wash in diesel oil or equal and put in new grease.
(Roller bearings)	Bearing worn due to lack of lubrication. Outer race of bearing scored.	Replace bearing. If old bearing, replace, if bearing is new or recently fitted, check fitting of the race into the end-shield and of the end-shield into the stator.
SYMPTOMS YOU CAN FEEL		
6 Vibration	Misalignment.	Re-align set.
	Vibration in driven machine. Run motor disconnected for check.	Eliminate source in machine, if possible A change to a flexible belt drive may help.
7 Vibration-following motor repair	Rotor out of balance, due to holes drilled or weights shifted due to new rotor coil or coils.	Re-balance rotor-dynamically if possible.
8 Motor over-heating. (Check with thermometer -do not depend on hand).	Overload. Measure load; compare with nameplate rating.	Check for excessive friction in motor, drive or machine. Reduce load, or replace with motor of greater capacity.
	Dirt in motor. Check flow of ventilating air.	Blow out motor. Use harmless cleaning solvent on wound section if necessary.
	Rotor rubbing on stator.	Replace bearings.
	Shorted star or windings.	Test with ammeter and correct.
9 Bearing overheating (Ball and roller bearings).	Earth (ground).	Locate with test lamp or insulation tester and repair.
	Misalignment of bearing	Check all machined faces for correct seating of bearings.
	Bearing on verge of collapse.	Inspect and replace if necessary.
(Oil bearings)	Over-greasing of bearings.	Sufficient grease should be placed in the bearing to allow easy running, but not packed so tightly that bearing has to plough through. Avoid packing grease too tightly into motor bearings where speed is 3,000 r.p.m. Or higher.
	Misalignment.	Re-align. In all cases of bearings overheating-keep shaft turning until bearing is cooled. . . To prevent "freezing" .
	Too much tension in chain or belt drive.	Reduce tension
	Excessive end thrust.	Reduce thrust from drive or machine. (Shaft should be permitted reasonable "axial" float). Or if motor is off level, shim-up lower end to take thrust off its bearing.

TYPES OF MOTOR BURNOUTS

- (1) **One coil only of one phase burnt out.** This could possibly be a fault in manufacture; the failure occurs within weeks of installation.
- (2) **One phase completely burnt out.** This is the usual failure on a Star-Delta or Delta connected motor and is invariably due to an external fault, for instance, a 'blown' fuse. This is described in detail in the diagram below.
- (3) **Two phases completely burnt out.** This can be traced to the same fault as 2, if the motor is Star connected.
- (4) **Motor completely burnt out.** This is almost invariably due to severe and sustained overload. If the motor is burnt out when stalled, this can be traced by the burning marks which appear on the slots of the rotor.

FLICKERING LIGHTS

Should a fairly large three-phase motor be connected in the Works, and the lights commence to flicker, suspect the rotor of the motor. The effect of one phase out of circuit on a three-phase motor on load is to generate a frequency different from that of the supply, and this can be easily noted by its effect on the lighting system. A fault on a rotor can usually be traced to one of the following-loose rotor lead, faulty rotor contact, dirty slip ring, or poor connection on short circuiting gear.

MOTOR BURNOUTS

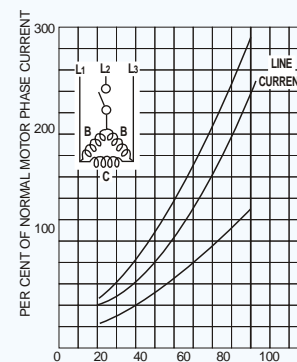

The accompanying diagram shows the circuit conditions in a normal three-phase Star-Delta wound motor, with one phase open, such as could be caused by a 'blown' fuse-this incidentally being the usual cause of a burnout. It will be observed that even at half-loading under these conditions, the circuit 'C' is carrying full load current. Full load with an open phase means that circuit 'C' has to carry nearly three times normal current, and under these conditions would be burnt out in a short time. The two phases 'B' would then be in series and actually carry little more than full load current.

EFFECT OF SPEED ON MOTOR CHARACTERISTICS

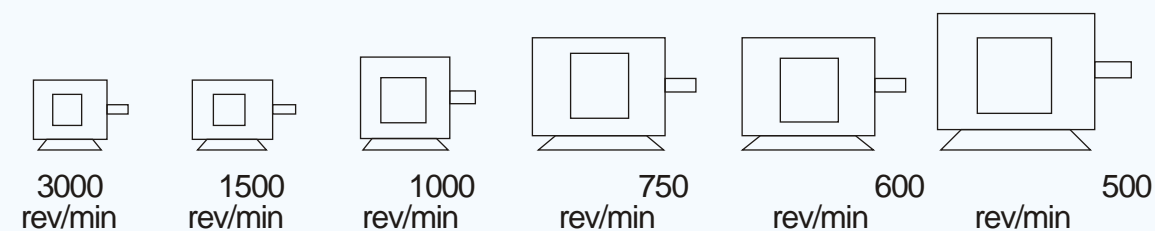

Relative sizes of a 4kW motor wound for various synchronous speeds.

Motor Speeds	3000	1500	1000	750	600	500
Frame Size	D112M	D112M	D132M	D160M	D160M	D180M
No. of Poles	2p	4p	6p	8p	10p	12p
Efficiency	82%	83%	83%	82%	81%	80%
Power Factor	86	81	80	74	67	68
Weight	1.0	1.0	1.2	1.9	2.1	3.2

EFFECTS OF VOLTAGE VARIATION

Electrical design aims at obtaining the optimum performance figures at rated voltage. Changes in voltage affect the following motor characteristics, speed, torque, current, efficiency, power factor and temperature rise. The statutory supply voltage regulations allow the voltage to vary $\pm 6\%$ from the declared voltage. The effects of these changes in voltage on the motor characteristics when operating at the extremes of the voltage are shown in the following table. These figures are quoted for guidance only since they can be affected by the polarity and kW rating of the motor.

Characteristic	Voltage +6%	Voltage -6%
Full Load Speed	0.5% increase	0.75% decrease
Locked Rotor Torque	12% "	11% "
Locked Rotor Current	6% "	5.5% "
Full Load Current	4% decrease	5% increase
Efficiency 1/2 F.L.	1.5% "	2% "
1/3 F.L.	1% "	Negligible Change
1/4 F.L.	Negligible Change	1% decrease
Power Factor 1/2 F.L.	4% decrease	4% increase
3/4 F.L.	3% decrease	2% increase
1/4 F.L.	2% "	1% "
Winding Temp. Rise	4% "	6% "

EFFICIENCY, POWER FACTOR AND FULL LOAD CURRENTS OF A.C. MOTORS

The figures given below are approximate only and based on Four Pole Motors running at 1500 rev/min. As the speed lowers the Power Factor and Efficiency for a given horse power tends to fall also.

The figures given should be easily obtainable on any good commercial machine. The Efficiency of a well designed Induction Motor is approximately constant between 75 per cent and 100 per cent of Full Load.

The current required for any Alternating Current Motor can be obtained from the following equations.

kW	FULL LOAD AMPS		EFFICIENCY F.L.		POWER FACTOR F.L.	
	3 Ph 415 V	1 Ph 240 V	3 Phase	1 Phase	3 Phase	1 Phase
0.75	1.93	7.7	77	67	.70	.61
1.1	2.7	10.5	77	70	.74	.63
1.5	3.5	13.0	80	65	.74	.74
2.2	4.9	14.4	80	75	.79	.85
3.0	6.6	18.4	80	78	.79	.87
4.0	8.3	32.0	83	83	.81	.85
5.5	11.0	-	85	-	.82	-
7.5	15.0	-	86	-	.83	-
11.0	21.0	-	88	-	.83	-
15.0	28.0	-	89	-	.83	-
22.0	40.0	-	89	-	.87	-
30.0	54.0	-	91	-	.84	-
37.0	66.0	-	91	-	.85	-
45.0	79.0	-	92	-	.87	-
55.0	96.0	-	92	-	.87	-
75.0	132.0	-	92	-	.87	-
110.0	180.0	-	92.5	-	.92	-
150.0	244.0	-	93	-	.92	-

AVOIDING BREAKDOWNS

Electric motors are reliable machines, but the following hints may prove of service. Avoid where possible-

- (1) Damp and falling moisture.
- (2) Dirt, especially fluff, which may cause blocked ventilation.
- (3) Inaccessible positions in case anything does go wrong.
- (4) Excessive heat. The permissible temperature rise of a motor with Class B insulation is 80 °C (measured by resistance). Surrounding air (ambient) temperature must not exceed 40 °C. A motor may overheat if it is over-loaded or if it is located in an area where the ambient temperature exceeds 40 °C. Other causes of overheating include blocked ventilation and duties which impose frequent or prolonged starting periods.

B.S. METRIC MOTORS—SHAFT DIMENSIONS

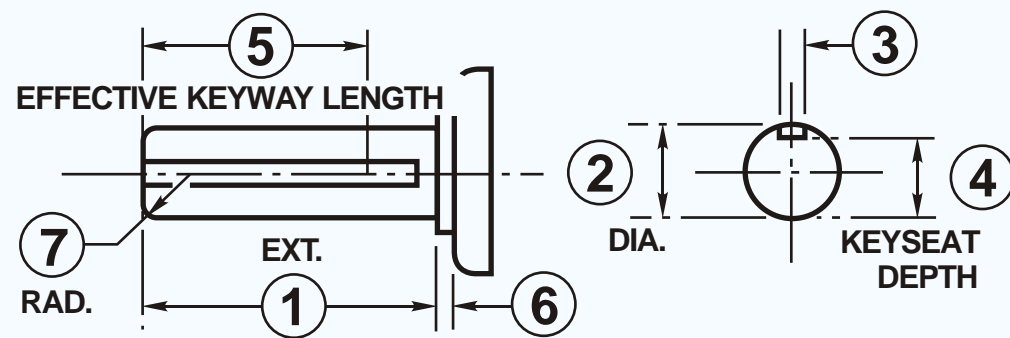

MILLIMETRES

Frame	1		2		3		4		5		6		7	
	2Pole	4,6,8 P	2Pole	4,6,8 P	2Pole	4,6,8 P	2Pole	4,6,8 P	2Pole	4,6,8 P	2Pole	4,6,8 P	2Pole	4,6,8 P
D.71	30		14		5X5		11		14		1.5		1.5875	
D.80	40		19		6X6		15.5		25		1.5		1.5875	
D.90	50		24		8X7		20.0		32		1.5		1.5875	
D.100	60		28		8X7		23.9		40		1.6		1.5875	
D.112	60		28		8X7		23.9		40		1.6		1.5875	
D.132	80		38		10X8		33.0		56		1.6		1.5875	
D.160	110		42		12X8		37.0		80		3.2		1.5875	
D.180	110		48		14X9		42.5		80		4.8		1.5875	
D.200	110		55		16X10		48.8		80		4.8		1.5875	
D.225	110		55		16X10		48.8		80		12.0		1.5875	
D.250	140	140	60	60	18X11	18X11	53	53	110	110	11.0		1.5875	
D.280	140	140	65	70	18X11	20X12	58	62.5	110	110	3.0		1.5875	
D.315S-M	140	170	65	80	18X11	20X12	58	71	110	140	3.0		1.5875	
D.315L		170		85		22X14		76		140	3.0		1.5875	
		170		90		25X14		81		140				

NOTICE:

Every endeavour has been made to publish correct information in this catalogue but no responsibility will be taken for errors, omissions or changes.

TRADING CONDITIONS

All sales are subject to our conditions of sale.

We reserve the right to change product prices, specification and conditions of sale without notice at any time.

Note: _____

