

SF300

Conventional fire alarm outdoor sounder

EN54-3

Description

SF300 is a conventional fire alarm outdoor sounder with two built-in piezo type sounders. It has a flat plastic cover, suitable for branding or placing of a logo sticker with dimensions up to 220x160mm. The siren is equipped with 2 LED flash indicators.



Technical and Environmental Specifications

Operating Voltage Range	20-30VDC
Consumption	<28mA@24VDC
Sound output	95dB@1m
Sounder Type	B
Built-in sounders	2, piezo
LED Indication	2 LEDs
Wire Gauge for Terminals	0.4mm ² - 2.0mm ²
Operating Temperature	-40°C to +85°C
Relative Humidity Resistance	(93 ± 3)% @ 40°C
Protection (for electronics)	IP44
Weight	~1.03kg
Dimensions	310x230x60mm
Materials (plastic), color	ABS, red



DoP No: 064
1293-CPR-0648
Tested by EVPU

Packing Information

- **Single packing box** - 1 unit SF300, dimensions 316x236x66mm
- **Carton packing box** - 5 units SF300, dimensions 360x345x252mm

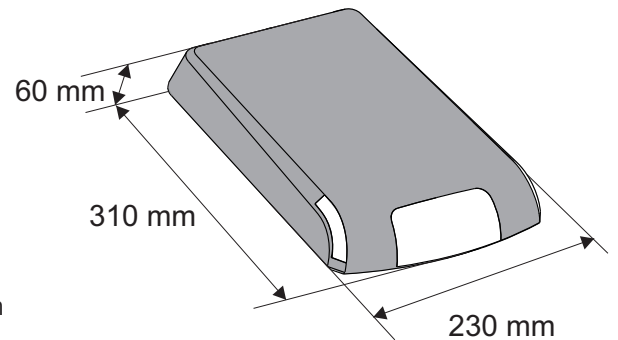

Compatible Product Range

- **MAG Series** - Conventional panels, 2/4/8/16 zones
- **IVY** - Extinguishing panel
- **IRIS and IRIS PRO** - Addressable panels, up to 4 loops, indication for 96 zones
- **SIMPO** - Addressable panel, up to 2 loops, 48 zones