

## SensoMAG S30

### Optical-Smoke Fire Alarm Detector

## EN54-7

### Description

SensoMAG S30 is an optical-smoke detector with digital processing algorithm. The detector is designed to detect smoke in the very early stage of the fire situation. SensoMAG S30 is suitable for installing in any conventional fire alarm system designed with fire alarm panel with fire alarm threshold between 10mA and 15mA.



### Technical and Environmental Specifications

Operating Voltage Range . . . . .	9 - 30 V DC (Nom. 12/24VDC)
Average current consumption in quiescent state . .	< 50µA
Alarm state current:	
- with base type B24 and B24D . . . . .	20 mA / 12÷30V
- with base type B24RD . . . . .	33 mA / 12V; 49mA/24V; 57mA/30V
- with base type B12L/U . . . . .	18 mA / 9V; 29mA/12V; 32mA/15V
Output in alarm state at terminal RI . . . . .	20mA (max)/ -3.3V (Towards terminals +IN /+OUT)
Degree of protection . . . . .	IP30
Wire Gauge for terminals . . . . .	0.4mm <sup>2</sup> ÷ 2.0mm <sup>2</sup>
Operational temperature range . . . . .	-10°C ÷ +60°C
Relative humidity resistance . . . . .	(93 ± 3)% @ 40°C
Dimensions (incl. base) . . . . .	ø102mm, h 42mm
Weight (incl. base) . . . . .	160g



DoP No: 089

1293-CPR-0637

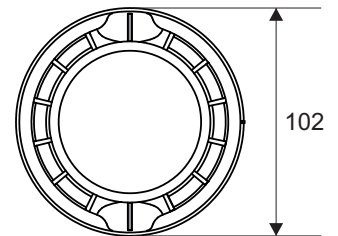
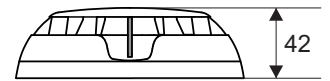

### Application

SensoMAG S30 is a high sensitive optical smoke detector. It is suitable for applications where early detection of smoke or fire is with great importance, for example office buildings, supermarkets, schools, etc.

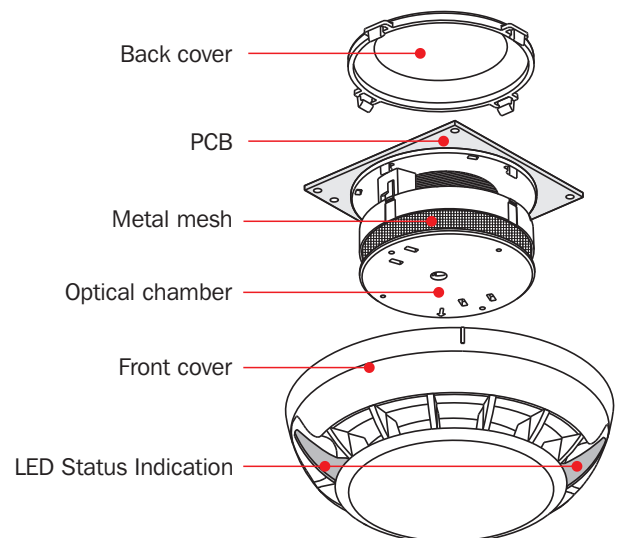

### Contact Information:

## SensoMAG S30 Optical-Smoke Fire Alarm Detector

**EN54-7**

### Packing Information

• **Master box** - 10 units SensoMAG S30, no bases included, dimensions 335 x 109 x 109 mm.  
All detectors are protected with a plastic cap.

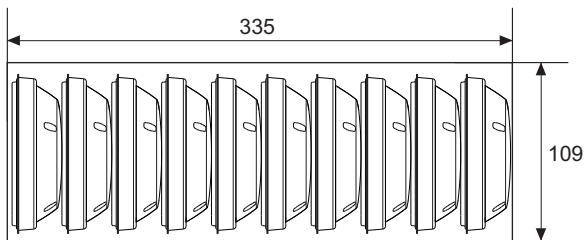

• **Carton box** - 100 units SensoMAG S30, (10 master boxes), no bases included, dimensions 556 x 345 x 231 mm.  
All detectors are protected with a plastic cap.

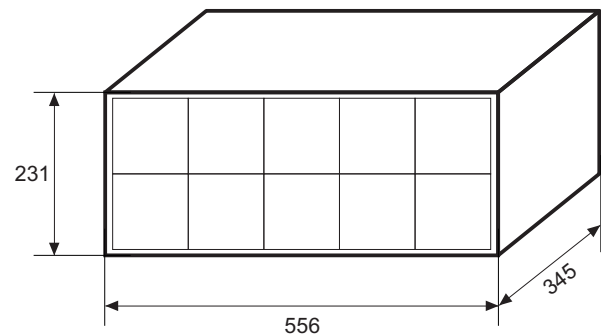

### Compatible Product Range

- **MAG2, MAG2P** - Conventional Fire Alarm Panel, 2 fixed zones
- **MAG4, MAG4P** - Conventional Fire Alarm Panel, 4 fixed zones
- **MAG8** - Conventional Fire Alarm Panel, 8 fixed zones
- **MAG8Plus** - Conventional Fire Alarm Panel, 8 fixed zones, expandable to 16
- **FRL-1** - Remote Fire Indicator
- **SensoMAG B24** - Standard Base
- **SensoMAG B24D** - Standard Base with Schottky diode
- **SensoMAG B24RD** - Standard Base with Schottky diode and increased alarm state current
- **SensoMAG B12L/U** - Base with relay output, 12V
- **Gasket ring** - Rubber gasket ring for extra protection of the smoke chamber
- **Deep Base** - Accessory for mounting on rough surfaces, outdoor pipelines, etc.