

TAD1346GE

12.78 liter, in-line 6 cylinder

FAMCO
هایپرمنعت

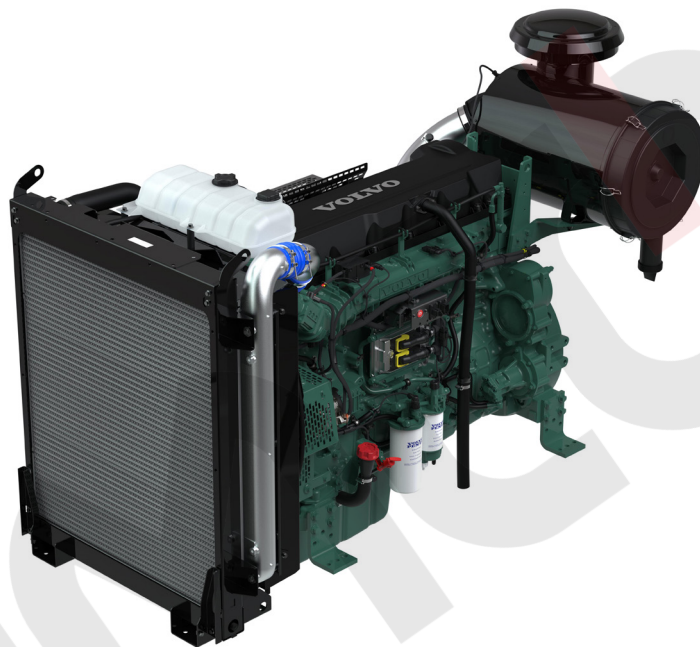

TAD1346GE is powerful, reliable and economical Generating Set Diesel Engines built on the dependable in-line six design.

Durability and low noise

Designed for easiest, fastest and most economical installation. Field tested to ensure highest standard of durability and long life. Well-balanced to produce smooth and vibration-free operation with low noise level.

To maintain a controlled working temperature in cylinders and combustion chambers, the engine is equipped with piston cooling. The engine is also fitted with replaceable cylinder liners and valve seats/guides to ensure maximum durability and service life of the engine.

Low exhaust emission

The state of the art, high-tech injection and charging system with low internal losses contributes to excellent combustion and low fuel consumption.

The emission levels for TAD1346GE equal to EU Stage 2. An electronically controlled viscous fan drive is available giving substantially lower noise and fuel consumption.

Easy service and maintenance

Easily accessible service and maintenance points contribute to the ease of service of the engine.

- Excellent load acceptance
- Highly efficient cooling system
- RoHS2 compliant
- Dual Speed 1500/1800 rpm
- EMS 2.4
- Wide range of optional equipment including visco fan

50 Hz / 1500 rpm

60 Hz / 1800 rpm

	Continuous power			Prime power			Standby power			Continuous power			Prime power			Standby power		
	kWm	kWe	kVA	kWm	kWe	kVA	kWm	kWe	kVA	kWm	kWe	kVA	kWm	kWe	kVA	kWm	kWe	kVA
TAD1346GE	320	301	377	427	402	502	470	442	552	327	307	384	436	409	512	479	450	563

Generator efficiency (typical): 94%

kWm = kiloWatt mechanical, net with fan*; kWe = kiloWatt electrical = kWm x Generator eff.; kVA = kiloVoltAmpere calculations based on a 0.8 power factor = kWe / 0.8

1 kW = 1 hp x 1.36; 1 hp = 1 kW x 0.7355

*) According to technical data

www.famcocorp.com

E-mail: info@famcocorp.com

@famco_group

Tel: ۰۲۱-۴۸۰۰۰۰۴۹

Fax: ۰۲۱-۴۴۹۹۴۶۴۲

تهران، کیلومتر ۲۱ بزرگراه لشگری (جاده مخصوص کرج)

روبروی پالایشگاه نفت پارس، پلاک ۱۲

TAD1346GE

12.78 liter, in-line 6 cylinder

FAMCO
هایپر صنعت

EN SAVOIR PLUS

Technical data

Configuration and no. of cylinders	in-line 6
Method of operation	4-stroke
Bore, mm (in.)	131 (5.16)
Stroke, mm (in.)	158 (6.22)
Displacement, l (in ³)	12.78 (780)
Compression ratio	17.8:1
Wet weight, kg (lb)	1243 (2470)
Wet weight with Gen Pac, kg (lb)	1455 (3208)

Performance

	1500 rpm	1800 rpm
Prime Power, kW (hp)	427 (581)	436 (593)
Standby Power, kW (hp)	470 (639)	479 (651)

Fuel consumption

Prime Power, g/kWh (lb/hph)

	1500 rpm	1800 rpm
25%	213 (0.345)	224 (0.363)
50%	199 (0.323)	201 (0.326)
75%	198 (0.320)	200 (0.323)
100%	191 (0.310)	196 (0.318)

Standby Power, g/kWh (lb/hph)

	1500 rpm	1800 rpm
25%	210 (0.341)	221 (0.359)
50%	198 (0.321)	202 (0.328)
75%	197 (0.319)	201 (0.326)
100%	191 (0.309)	196 (0.318)

Dimensions

Not for installation. Dimensions in mm.

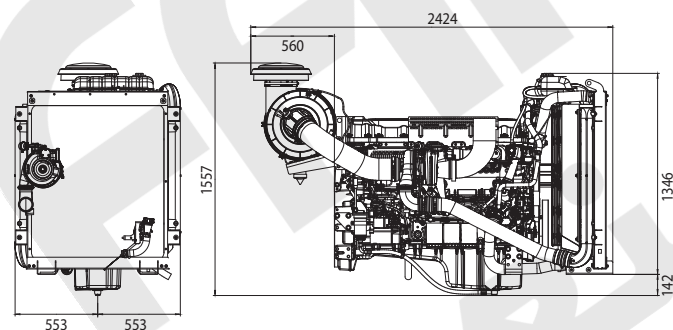

Please note that products illustrated may differ from production models. Not all models and accessories are available in all markets, and standard equipment may vary between different markets. Every effort has been made to ensure that facts and figures are correct at the time of publication. However, Volvo Penta reserves the right to make changes without prior notice at any time.

Rating guidelines

CONTINUOUS POWER is defined as being the maximum power which the generating set is capable of delivering continuously while supplying a constant electrical load when operated for an unlimited number of hours per year under the agreed operating conditions with the maintenance intervals and procedures being carried out as prescribed by the manufacturer.

PRIME POWER rating corresponds to ISO Standard Power for continuous operation. It is applicable for supplying electrical power at variable load for an unlimited number of hours instead of commercially purchased power. A10 % overload capability for governing purpose is available for this rating.

STAND-BY POWER rating corresponds to ISO Standard Fuel Stop Power. It is applicable for supplying stand-by electrical power at variable load in areas with well established electrical networks in the event of normal utility power failure. No overload capability is available for this rating.

Technical description

Engine and block

- Optimized cast iron cylinder block with optimum distribution of forces without the block being unnecessary heavy.
- Wet, replaceable cylinder liners
- Piston cooling for low piston temperature and reduced ring temperature
- Tapered connecting rods for increased piston lifetime
- Crankshaft induction hardened bearing surfaces and fillets with seven main bearings for moderate load on main and high-end bearings
- Case hardened and Nitrocarburized transmission gears for heavy duty operation
- Keystone top compression rings for long service life
- Viscous type crankshaft vibration damper to withstand single bearing alternator torsional vibrations
- Replaceable valve guides and valve seats
- Over head camshaft and four valves per cylinder

Lubrication system

- Full flow oil cooler
- Full flow disposable spin-on oil filters, for extra high filtration
- The lubricating oil level can be measured during operation
- Gear type lubricating oil pump, gear driven by the transmission

Fuel system

- Electronic high pressure unit injectors
- Fuel prefilter with water separator and water-in-fuel indicator / alarm
- Gear driven low-pressure fuel pump
- Fine fuel filter with manual feed pump and fuel pressure switch

Cooling system

- Efficient cooling with accurate coolant control through a water distribution duct in the cylinder block. Reliable sleeve thermostat with minimum pressure drop
- Belt driven coolant pump with high degree of efficiency
- Electronically controlled viscous fan drive provides lower noise and fuel consumption (optional).

Turbo charger

- Efficient and reliable turbo charger
- Extra oil filter for the turbo charger

Electrical system

- Engine Management System 2 (EMS 2.4), an electronically controlled processing system which optimizes engine performance. It also includes advanced facilities for diagnostics and fault tracing.
- The instruments and controls connect to the engine via the CAN SAE J1939 interface, either through the Control Interface Module (CIM) or the Digital Control Unit (DCU). The CIM converts the digital CAN bus signal to an analog signal, making it possible to connect a variety of instruments. The DCU2 is a control panel with display, engine control, monitoring, alarm, parameter setting and diagnostic functions. The DCU2 also presents error codes in clear text.
- Sensors for oil pressure, oil temp, boost pressure, boost temp, coolant-temp, fuel temp, water in fuel, fuel pressure and two speed sensors.

Power standards

The engine performance corresponds to ISO 3046, BS 5514 and DIN 6271. The technical data applies to an engine without cooling fan and operating on a fuel with calorific value of 42.7 MJ /kg (18360 BTU/lb) and a density of 0.84 kg/liter (7.01 lb/US gal), also where this involves a deviation from the standards. Power output guaranteed within 0 to +2% at rated ambient conditions at delivery. Ratings are based on ISO 8528. Engine speed governing in accordance with ISO 8528-5 G3.

Please contact your local Volvo Penta dealer for further information.



AB Volvo Penta