

## Overview

### Applicable scope

NXR thermal overload relays (hereinafter abbreviated as thermal relays) are suitable for overload and phase loss protection for uninterrupted or intermittent AC motors with AC frequency of 50 Hz/60 Hz, a voltage up to 690 V, and a current of (0.1-630)A.

The thermal relays also provide temperature compensation, action indication, automatic and manual reset, stop, and testing functions. The products are characterized by stable and reliable performance. The thermal relays can be plugged into contactors or installed independently.

Compliant standards: IEC/EN 60947-4-1, IEC/EN 60947-5-1.

### Structural characteristics

- Three-phase bi-metal sheet type or electronic type (NXR-200, NXR-630), with a tripping level of 10A
- With phase loss protection
- With a device for continuous adjustment of setting current
- With temperature compensation
- With action indication
- With testing mechanism
- With stop bottom
- With manual and automatic reset button (NXR-200 and NXR-630 only have manual reset)
- With one NO contact and one NC contact that are electrically separable
- Installation method: Plugged into contactor (NXR-12, 25, 38, 100) or installed independently (NXR-200, 630)
- Protection characteristics

### Operation environment

Type	Operation and installation conditions
Installation type	III
Pollution degree	3
Compliant standards	IEC/EN 60947-4-1, IEC/EN 60947-5-1
Certification mark	CE
Enclosure protection degree	IP20 (NXR-12, 25, 38, 100)
Ambient temperature	Operation temperature limits: -35°C~+70°C. Normal operation temperature range: -5°C~+40°C. The 24-hour average temperature should not exceed +35°C. For use beyond the normal operation temperature range, see "Instructions for use in abnormal conditions" in the annex.
Altitude	Not exceeding 2000m above sea level
Atmospheric conditions	The relative humidity should not exceed 50% at the upper temperature limit of +70°C. A higher relative humidity is allowed at a lower temperature, e.g. 90% at +20°C. Special precautions should be taken against occasional condensation due to humidity variations.
Installation conditions	The angle between the installation surface and the vertical surface should not exceed ±5°.
Shock and vibration	The product should be installed in places without significant shaking, shock, and vibration.



## Description

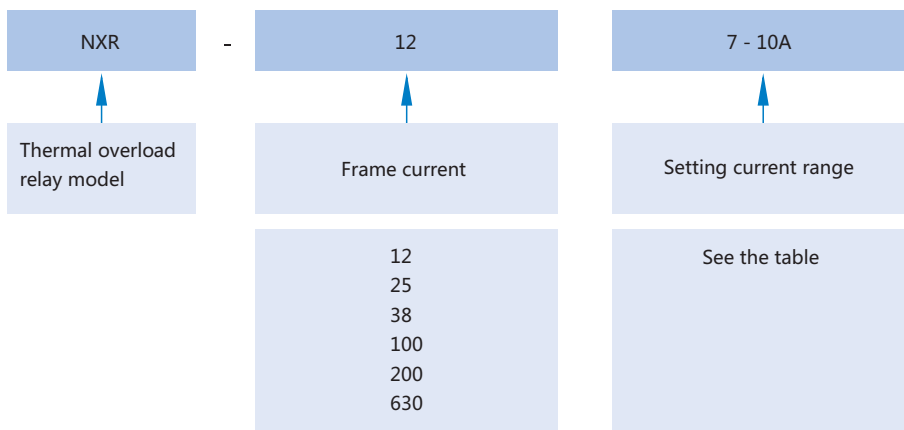
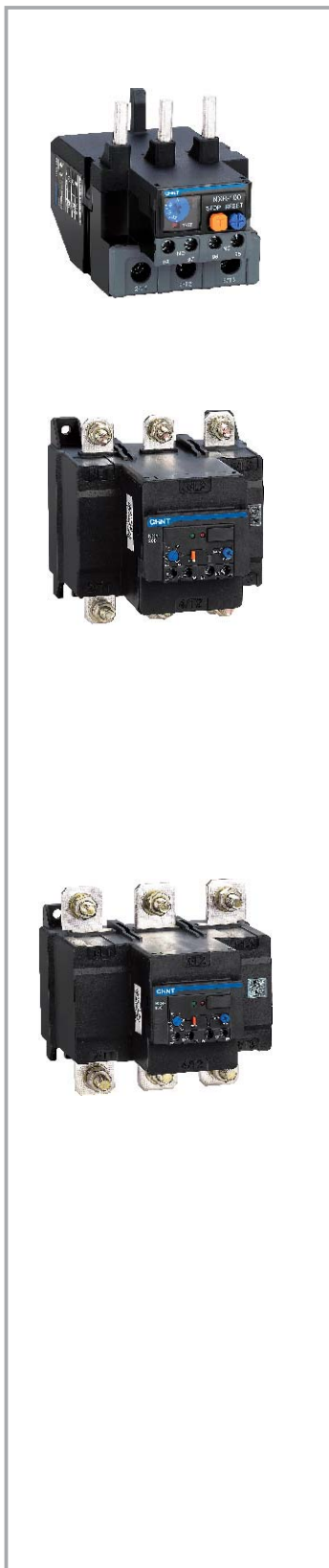

Frame	Setting current
12	0.1-0.16A
	0.16-0.25A
	0.25-0.4A
	0.4-0.63A
	0.63-1A
	1-1.6A
	1.25-2A
	1.6-2.5A
	2.5-4A
	4-6A
	5.5-8A
	7-10A
9-12A	

Frame	Setting current
25	0.1-0.16A
	0.16-0.25A
	0.25-0.4A
	0.4-0.63A
	0.63-1A
	1-1.6A
	1.25-2A
	1.6-2.5A
	2.5-4A
	4-6A
	5.5-8A
	7-10A
9-13A	
12-18A	
17-25A	

Frame	Setting current
38	23-32A
	30-38A
	23-32A
100	30-40A
	37-50A
	48-65A
	55-70A
200	63-80A
	80-93A
	80-100A
630	80-160A
	100-200A
	125-250A
630	200-400A
	315-630A

Selection example:

"NXR-25 7-10A" represents a NXR 3P thermal overload relay with a frame current class of 25 and a setting current range between 7A and 10A.

## MB mounting base

	Type	Application
	MB-1	Incorporate with NXR-12 to be an independant mounted product
	MB-2	Incorporate with NXR-25 to be an independant mounted product
	MB-3	Incorporate with NXR-38 to be an independant mounted product
	MB-4	Incorporate with NXR-100 to be an independant mounted product

## Quick selection and matching table

Product appearance	Rated current A	Specification of matching fuse (RT16 recommended) A	Model of matching contactor
		gG	
 NXR-12	0.1~0.16	2	 NXC-06M, 09M, 12M
	0.16~0.25	2	
	0.25~0.4	2	
	0.4~0.63	2	
	0.63~1	4	
	1~1.6	4	
	1.25~2	6	
	1.6~2.5	6	
	2.5~4	10	
	4~6	16	
	5.5~8	20	
	7~10	20	
9~12	25		
 NXR-25	0.1~0.16	2	 NXC-06, 09, 12, 16, 18, 22, 25, 32, 38
	0.16~0.25	2	
	0.25~0.4	2	
	0.4~0.63	2	
	0.63~1	4	
	1~1.6	4	
	1.25~2	6	
	1.6~2.5	6	
	2.5~4	10	
	4~6	16	
	5.5~8	20	
	7~10	20	
9~13	25		
12~18	35		
17~25	50		
 NXR-38	23~32	63	 NXC-25, 32, 38
	30~38	80	
 NXR-100	23~32	63	 NXC-40, 50, 65, 75, 85, 100
	30~40	100	
	37~50	100	
	48~65	100	
	55~70	125	
	63~80	125	
	80~93	160	
80~100	160		
 NXR-200	80~160	315	 NXC-120, 160, 185, 225
	125~200	315	
 NXR-630	125~250	800	 NXC-225, 265, 330, 400, 500, 630
	200~400	800	
	315~630	800	

## Parameters

Item	NXR-12	NXR-25	NXR-38	NXR-100	NXR-200	NXR-630		
Current level	12	25	38	100	200	630		
Rated insulation voltage V	690	690	690	690	690	690		
Rated impulse withstand voltage V	6000	6000	6000	6000	6000	6000		
Enclosure protection degree	IP20	IP20	IP20	IP20	-	-		
Phase loss protection	Yes	Yes	Yes	Yes	Yes	Yes		
Manual and automatic reset	Yes	Yes	Yes	Yes	Manual	Manual		
Temperature compensation	Yes	Yes	Yes	Yes	Yes	Yes		
Trip indication	Yes	Yes	Yes	Yes	Yes	Yes		
Test button	Yes	Yes	Yes	Yes	Yes	Yes		
Stop button	Yes	Yes	Yes	Yes	Yes	Yes		
Installation method	Plugged	Plugged	Plugged	Plugged	Independent	Independent		
Integrated auxiliary contact	1NO+1NC	1NO+1NC	1NO+1NC	1NO+1NC	1NO+1NC	1NO+1NC		
AC-15 380V/400V/415V rated current A	1.5	1.5	1.5	1.5	1.5	1.5		
DC-13 220V rated current A	0.2	0.2	0.2	0.2	0.2	0.2		
Conductor cross section mm <sup>2</sup>	Main circuit	Single-core or stranded wire	1~4	1~6	4~10	4~35	25~95	50~2×185
		Wiring screw	M3.5	M4	M4	M10	M8	M10
		Tightening torque (N·m)	0.8	0.8	0.8	0.8	1.2	1.2
	Auxiliary circuit	Single-core or stranded wire	1~2.5	1~2.5	1~2.5	1~2.5	1~2.5	1~2.5
		Wiring screw	M3.5	M3.5	M3.5	M3.5	M3.5	M3.5
		Tightening torque (N·m)	1.2	1.7	1.7	10	10	20

## Protection characteristics

Item	No.	Multiples of setting current		Action time	Test conditions
Overload protection	1	1.05		Without action in 2 hours	Start from cold state
	2	1.2		Act within 2 hours	Start from hot state (after No. 1)
	3	1.5		Act within 2 minutes	Start after thermal equilibrium is reached under setting current
	4	7.2		2s < T <sub>p</sub> ≤ 10s	Start from cold state
Phase loss protection	5	Any two phases	The other phase	Without action in 2 hours	Start from cold state
		1.0	0.9		
	6	1.15	0	Act within 2 hours	Start from hot state (after No. 5)

## Trip characteristics

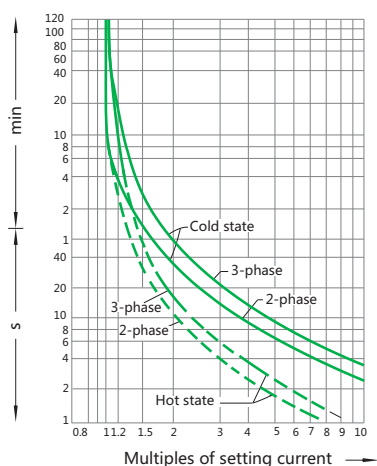

Thermal relay time Vs current characteristics curve (+20°C)

## Product front view

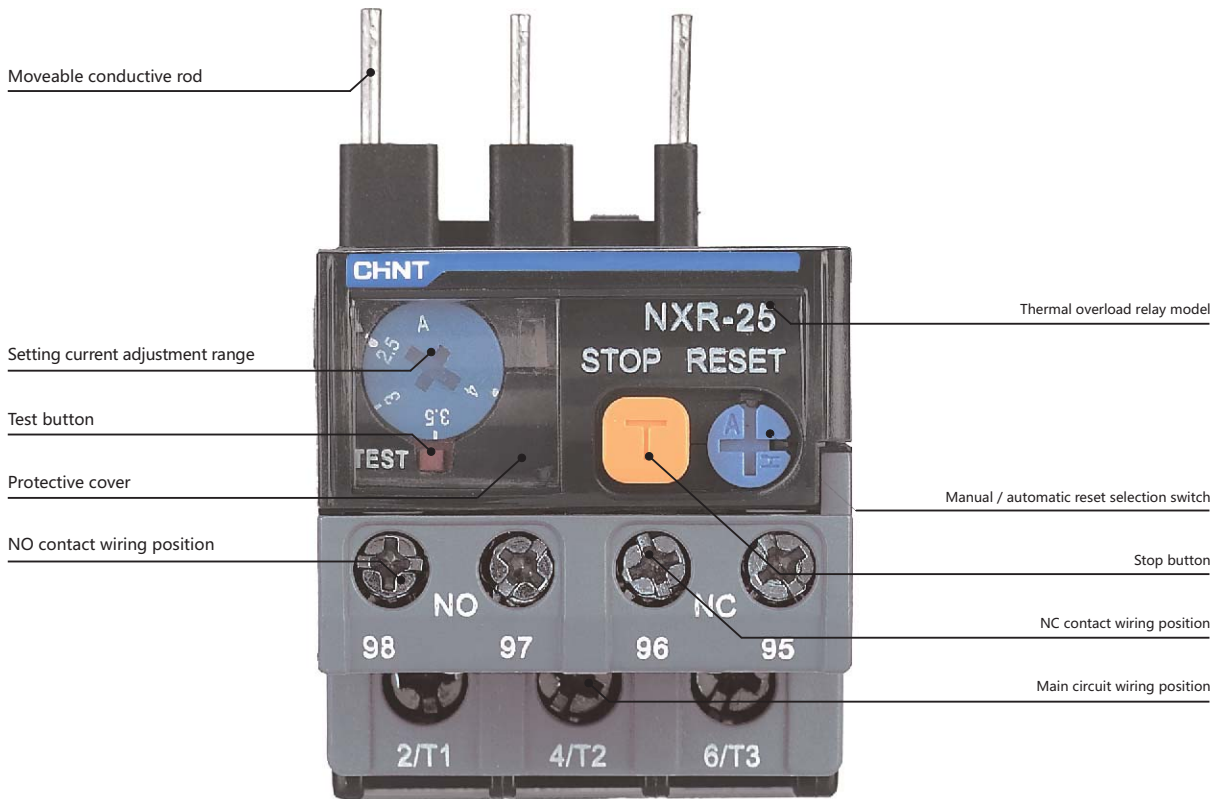

## Dimensions and installation

NXR-12

Dimensions and installation

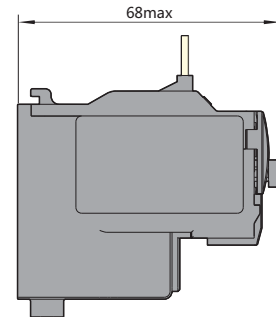
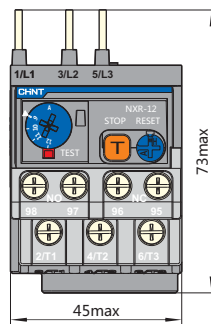

NXR-25

Dimensions and installation

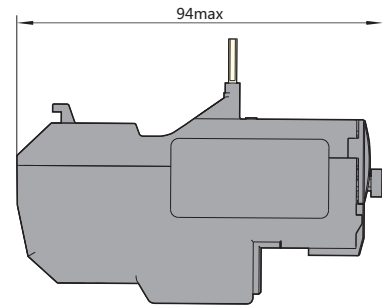
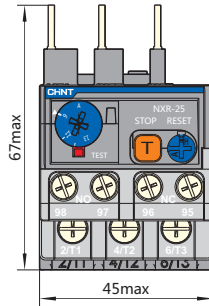

NXR-38

Dimensions and installation

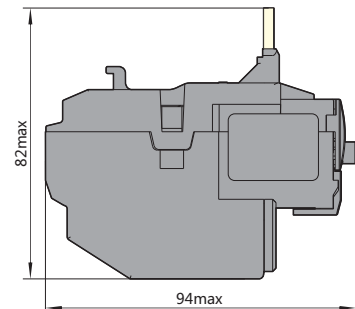
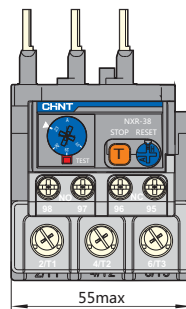

NXR-100

Dimensions and installation

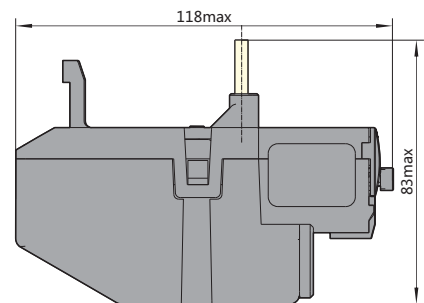
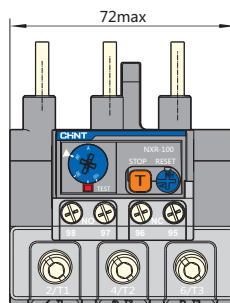

NXR-200

Dimensions and installation

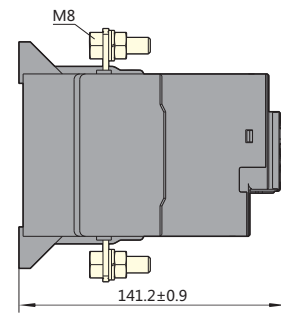
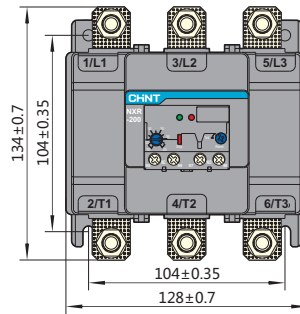

NXR-630

Dimensions and installation

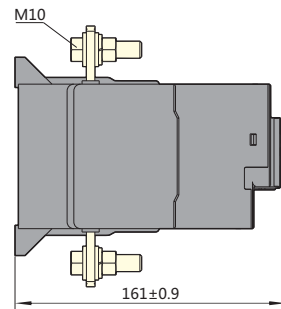
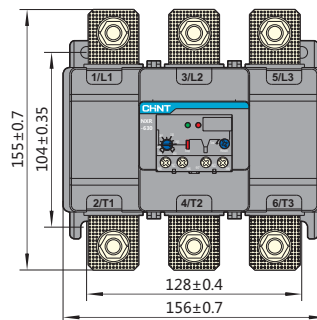

### Sizes of combination with contactors

NXC-06M + NXR-12

Dimensions and installation

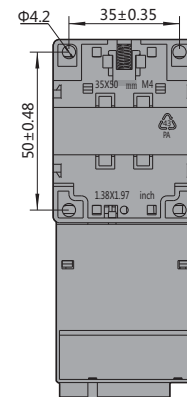
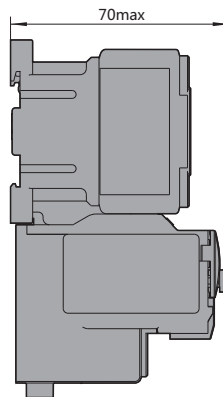
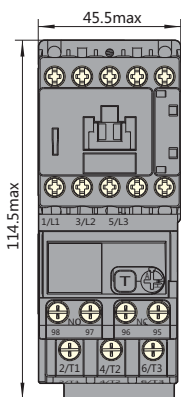

NXC-09 + NXR-25

Dimensions and installation

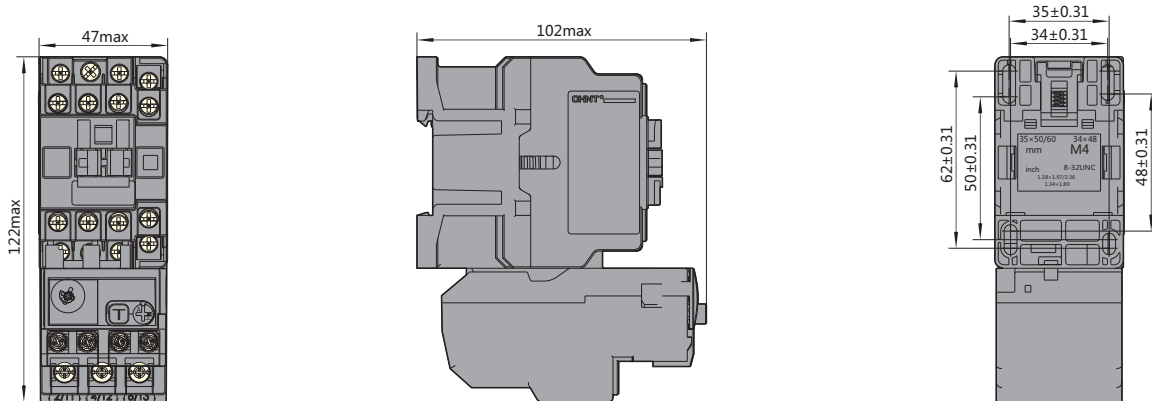

NXC-18 + NXR-25

Dimensions and installation

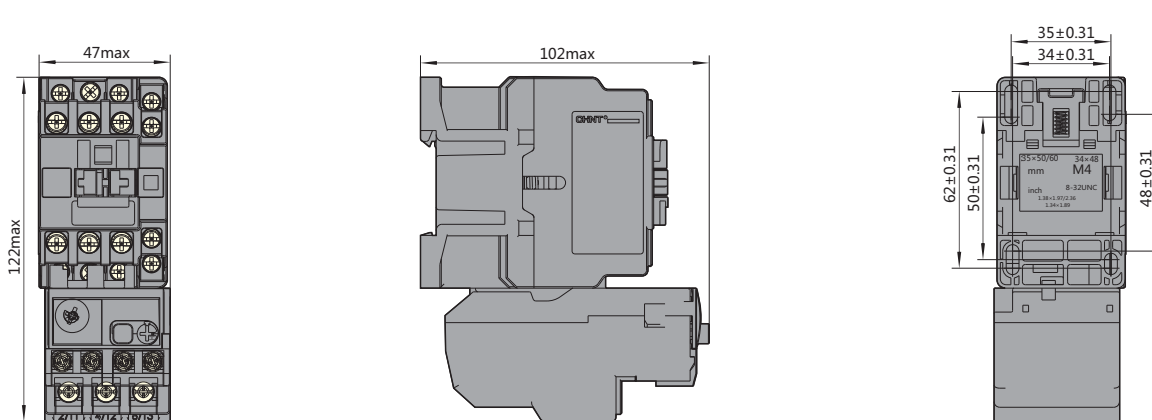

NXC-38 + NXR-25

Dimensions and installation

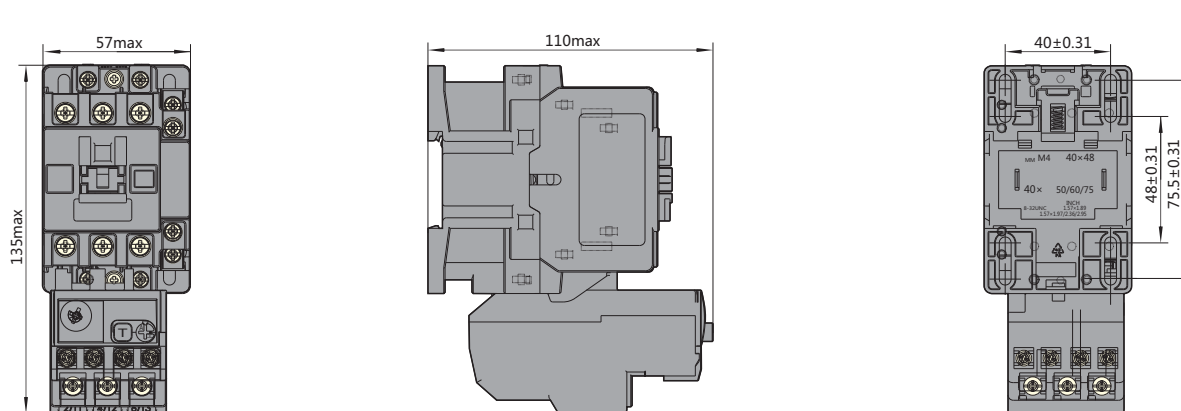



NXC-38 + NXR-38

Dimensions and installation

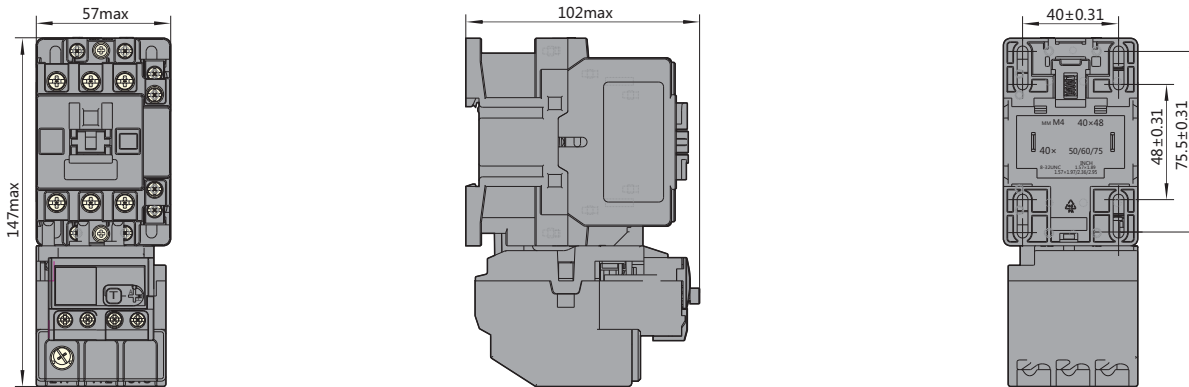

NXC-40 + NXR-100

Dimensions and installation

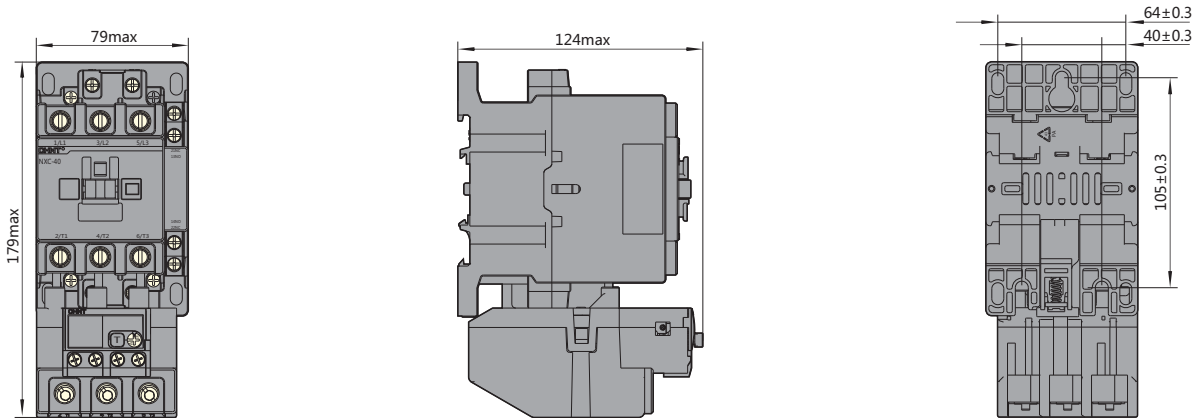

NXC-75 + NXR-100

Dimensions and installation

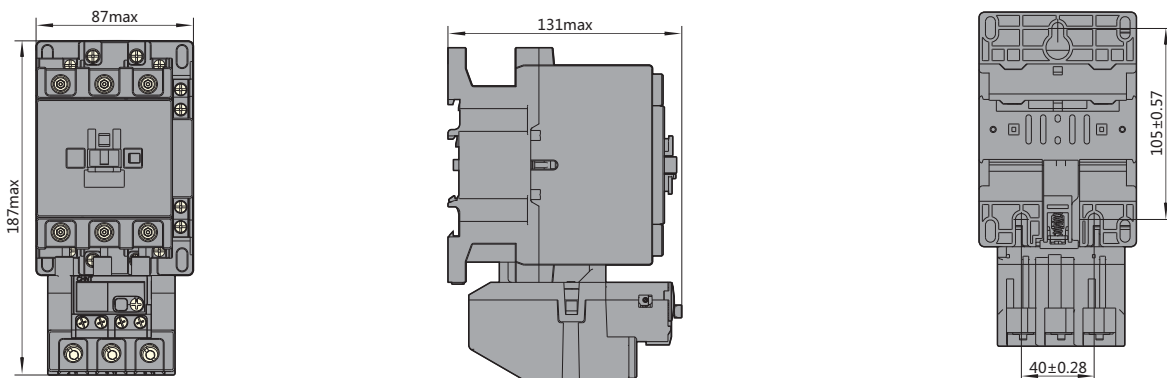

## Wiring diagrams

NXR-12~100

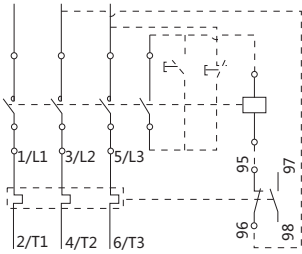

NXR-200~630

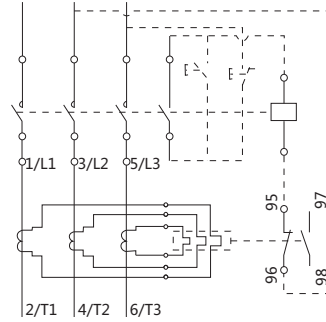

## Annex I: Instructions for use in abnormal conditions

- IEC/EN 60947-4-1 standard defines normal operation temperature range for products. Use of products in the normal range will not cause significant impact on their performance.
- At an operation temperature higher than +40°C, the tolerable temperature rise of products needs to be reduced. The rated operation current should be adjusted to prevent product damage, shortened service life, lower reliability, or impact on action characteristics. At a temperature lower than -5°C, impact of changes to the heat dissipation system on the action characteristics of the products should be considered.
- The temperature compensation coefficients at an ambient temperature higher than +40°C and lower than -5°C are given below. The compensation coefficients corresponding to -35°C and +70°C environments are given in the table below. No corrections are required for NXR-200 and NXR-630.

Operation ambient temperature		-35°C	+70°C
Temperature compensation coefficients for NXR-12, 25, 38, 100	Multiple of stable current	1.05	0.9
	Multiple of trip current	1.4	1.2

NXR-12, 25, 38, 100

Temperature compensation curve

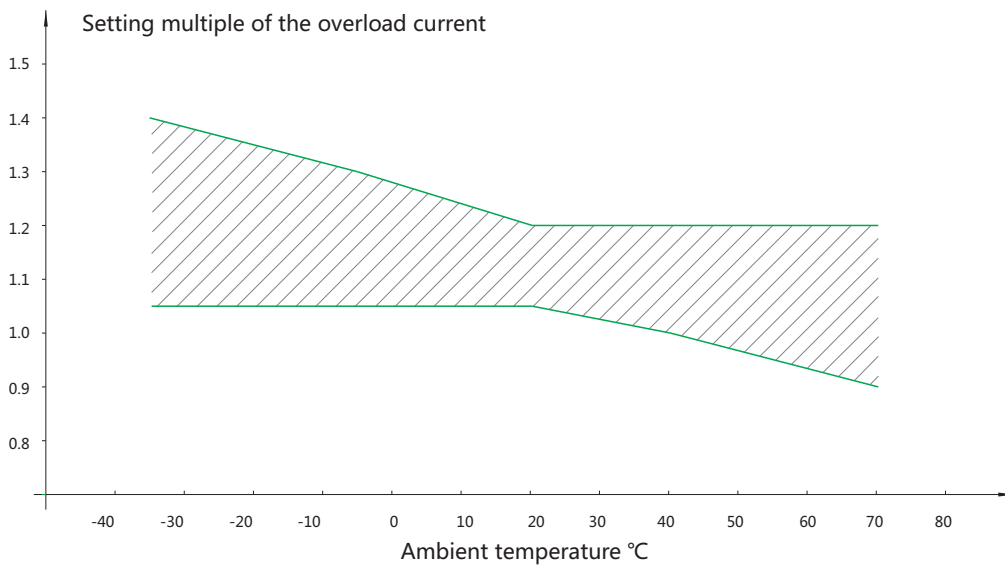



## NR2 Thermal Overloa

### 1. General

1.1 Certificates: CE, KEMA, UkrSEPRO, EAC, RCC, UL;

1.2 Electric ratings: AC 50/60Hz, 690V, 0.1A~630A;

1.3 Tripping class: 10A;

1.4 Mounting version:

- a. Plug-in: Available for NR2-11.5, 25, 36, 93, 150;
- b. Independent: Available for NR2-200, 630;

1.5 Standard: IEC/EN 60947-4-1

### 2. Type designation

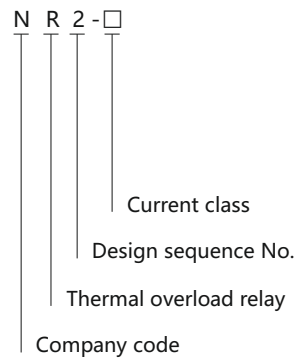

### 3. Features

- 3.1 3-phase bimetal
- 3.2 Continuously readjustable current settings
- 3.3 Temperature compensation
- 3.4 Tripping indicator
- 3.5 Test button
- 3.6 Stop button
- 3.7 Manual and automatic reset button
- 3.8 Electrically separated 1N/O plus 1N/C contact

#### 4. Technical data

##### 4.1 Protection properties

Item	Series No.	I/In	Operating time Tp	Test condition	
Overload protection	1	1.05	>2 h	Start from cold status	
	2	1.2	≤2 h	Start from heat status, right after item No.1	
	3	1.5	≤2 min	Start from heat status, right after item No.1	
	4	7.2	2s < Tp ≤ 10s	Start from cold status	
Phase failure protection	5	Any two phases	Another phase	>2 h	Start from cold status
		1.0	0.9		
	6	1.15	0	≤2 h	Start from heat status, right after item No.5

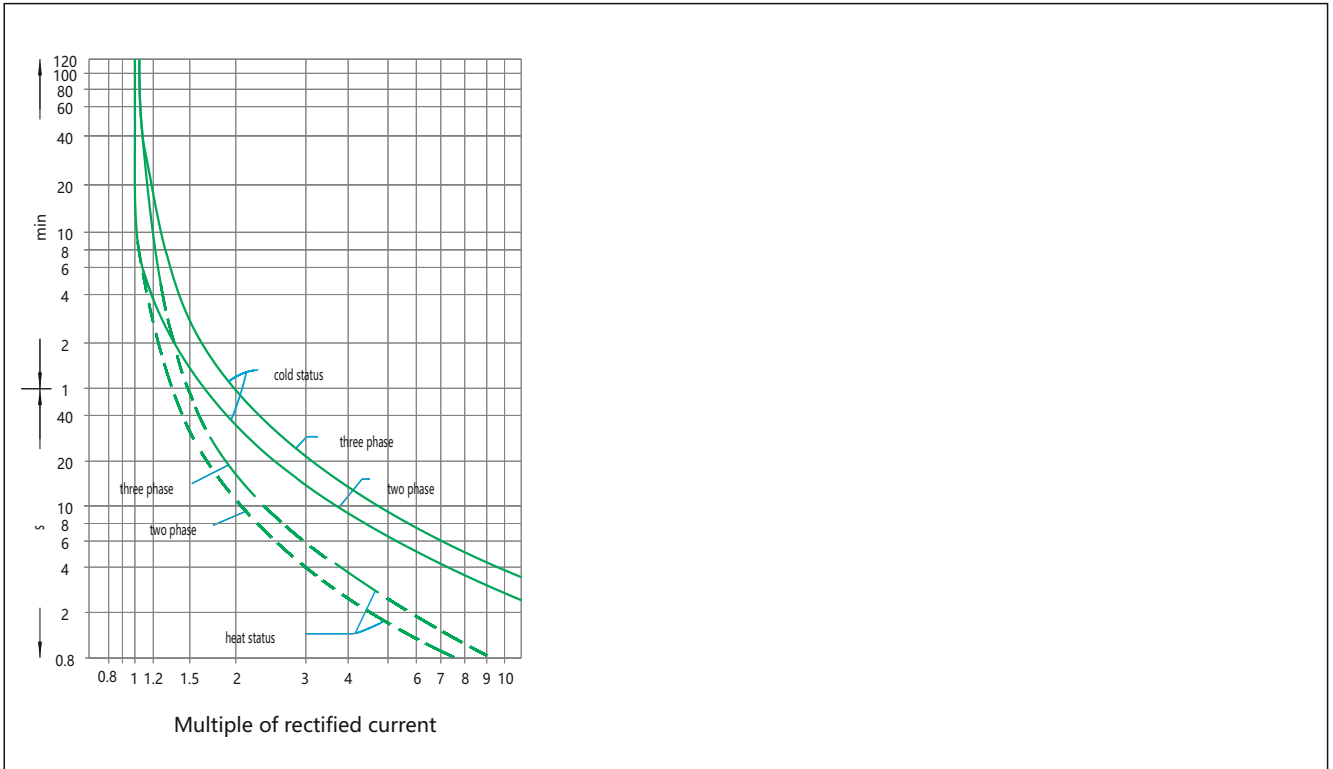

##### Curves







## 4.2 Main Technical Parameters

Model		NR2-11.5							
Picture									
Current class(A)		13							
Phase failure protection function		Yes							
Automatic & manual reset		Yes							
Temperature compensation		Yes							
Tripping indicator		Yes							
Test & stop pushbutton		Yes							
Mounting mode	Plug-in	Yes							
	Independent	Yes							
Auxiliary contacts	No. of contacts	1N/O+1N/C							
	Rated current (A) (AC-15 220V)	2.73							
	Rated current (A) (AC-15 380V)	1.58							
	Rated current (A) (DC-13 220V)	0.2							
Rated operational current(A)		Current setting range							
Matched fuse	aM(A)	0.1~0.16	0.16~0.25	0.25~0.40	0.40~0.63	0.63~1	1~1.6	1.25~2	
	gG(A)	2	2	2	2	4	4	6	

Model		NR2-93							
Picture									
Current class(A)		93							
Phase failure protection function		Yes							
Automatic & manual reset		Yes							
Temperature compensation		Yes							
Tripping indicator		Yes							
Test & stop pushbutton		Yes							
Mounting mode	Plug-in	Yes							
	Independent	Yes							
Auxiliary contacts	Configuration of contacts	1N/O+1N/C							
	Rated current (A) (AC-15 220V)	2.73							
	Rated current (A) (AC-15 380V)	1.58							
	Rated current (A) (DC-13 220V)	0.2							
Rated operational current(A)		Current setting range							
Matched fuse	aM(A)	23~32	30~40	37~50	48~65	55~70	63~80	80~93	
	gG(A)	40	40	63	63	80	80	100	
		63	100	100	100	125	125	160	

NR2-25								NR2-36	
									
25								36	
Yes								Yes	
Yes								Yes	
Yes								Yes	
Yes								Yes	
Yes								Yes	
Yes								Yes	
Yes								Yes	
1N/O+1N/C								1N/O+1N/C	
2.73								2.73	
1.58								1.58	
0.2								0.2	
Current setting range								Current setting range	
1.6~2.5	2.5~4	4~6	5.5~8	7~10	9~13	12~18	17~25	23~32	28~36
4	6	8	12	12	16	20	25	40	40
6	10	16	20	20	25	35	50	63	80

NR2-150			NR2-200			NR2-630					
											
150			200			630					
Yes			Yes			Yes					
Yes			Yes			Yes					
Yes			Yes			Yes					
Yes			Yes			Yes					
Yes			Yes			Yes					
Yes			No			No					
No			Yes			Yes					
1N/O+1N/C			1N/O+1N/C			1N/O+1N/C					
2.73			2.73			2.73					
1.58			1.58			1.58					
0.2			0.2			0.2					
Current setting range			Current setting range			Current setting range					
80~104	95~120	110~150	80~125	100~160	125~200	160~250	200~315	250~400	315~500	400~630	
125	125	160	125	160	200	250	315	400	500	630	
200	224	250	200	250	315	400	500	630	800	800	

5. Overall and mounting dimensions (mm)

NR2-11.5

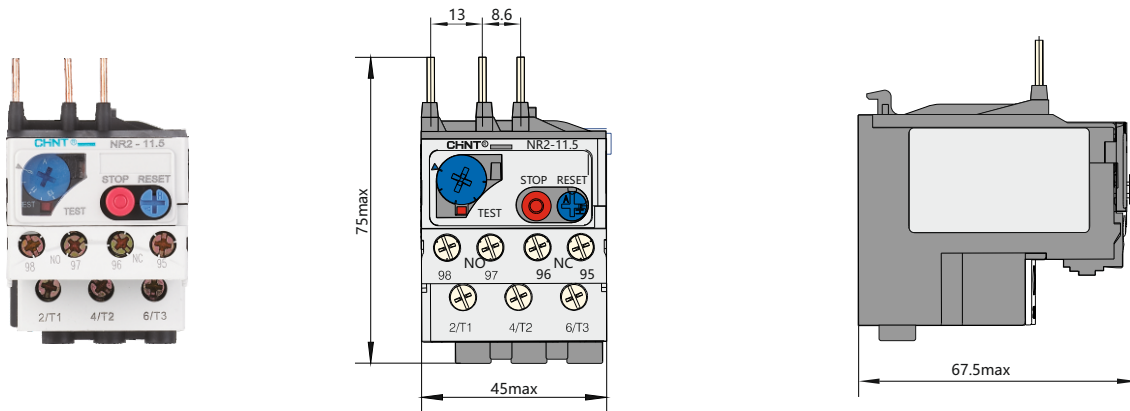

NR2-11.5 with MB-1

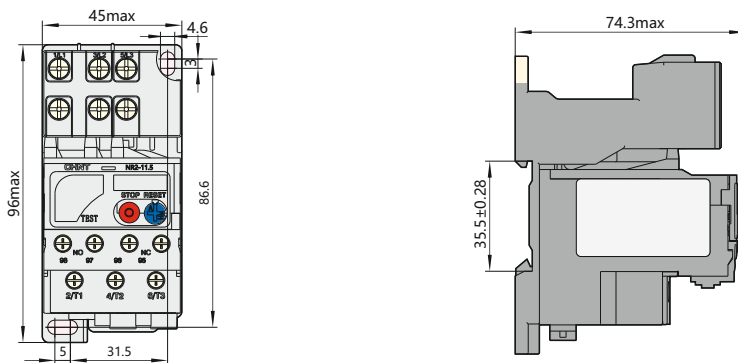

NR2-25

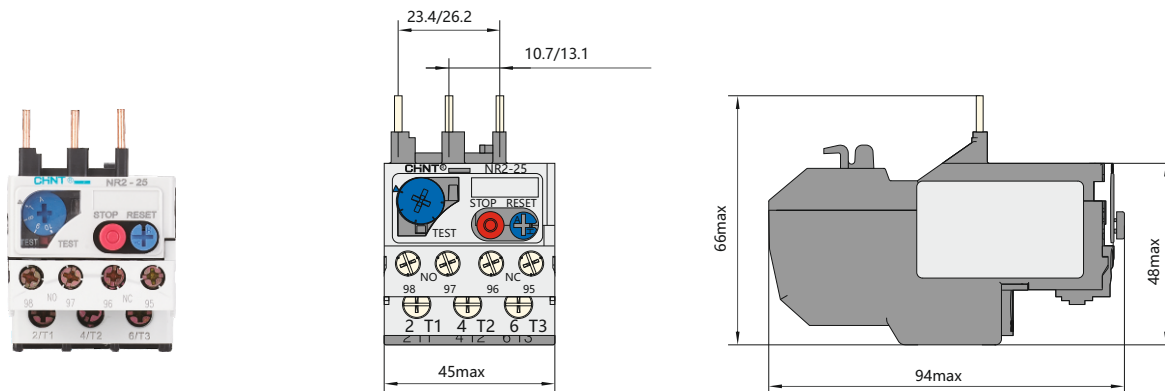

NR2-25 with MB-2

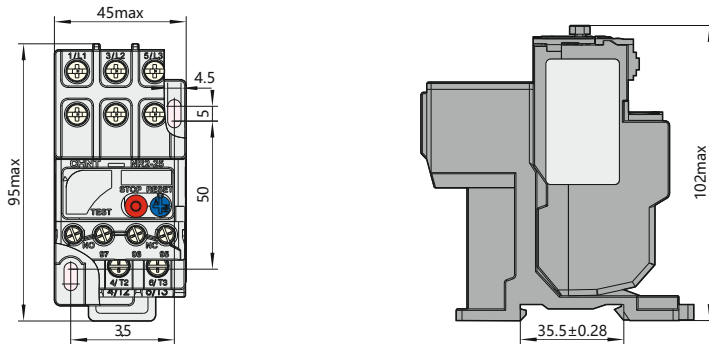

NR2-36

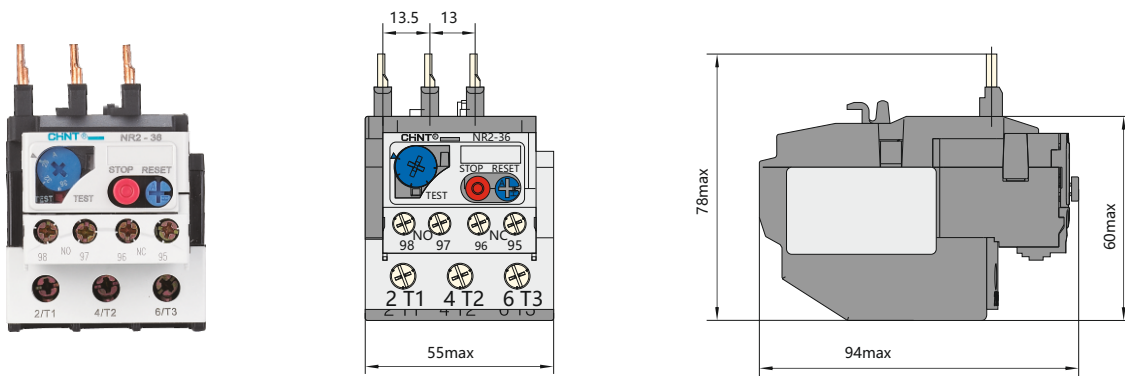

NR2-36 with MB-3

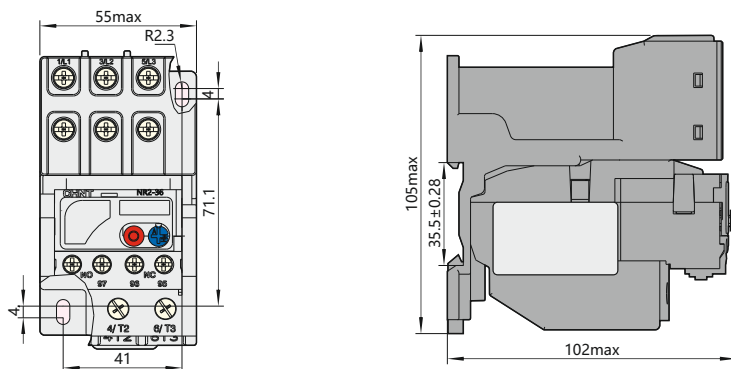



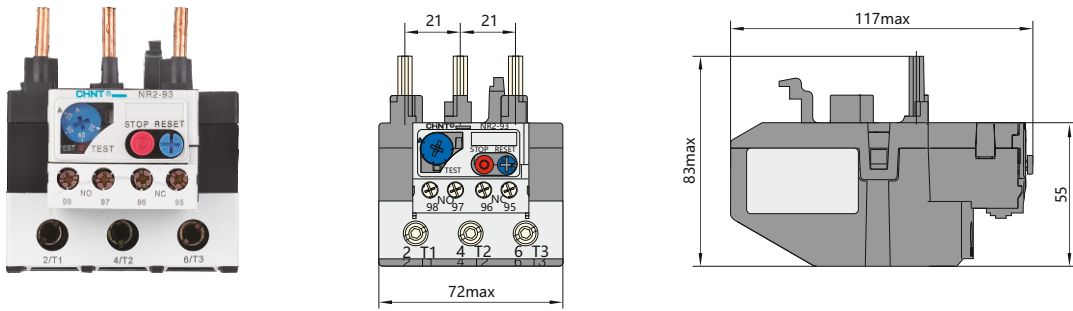

NR2-93 with MB-4

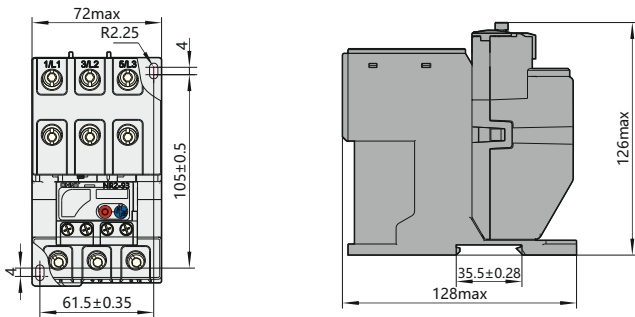

NR2-150 (matched with NC2)

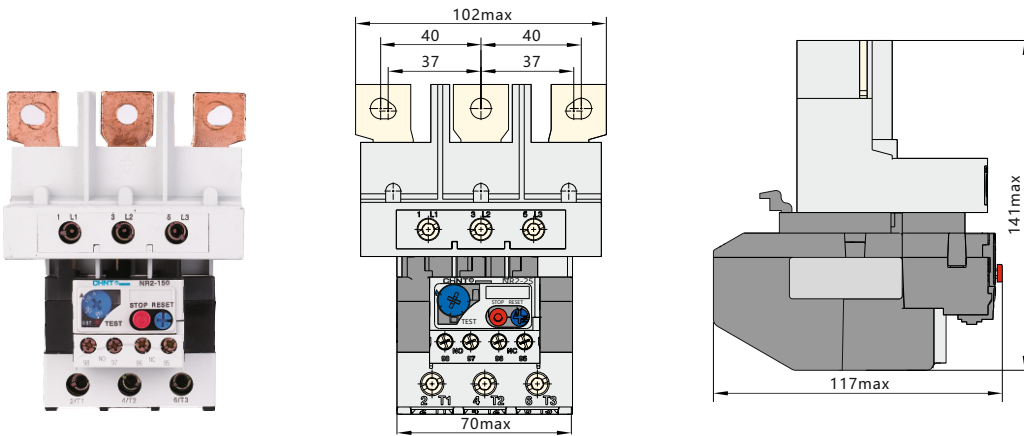

NR2-150 (matched with NC7)

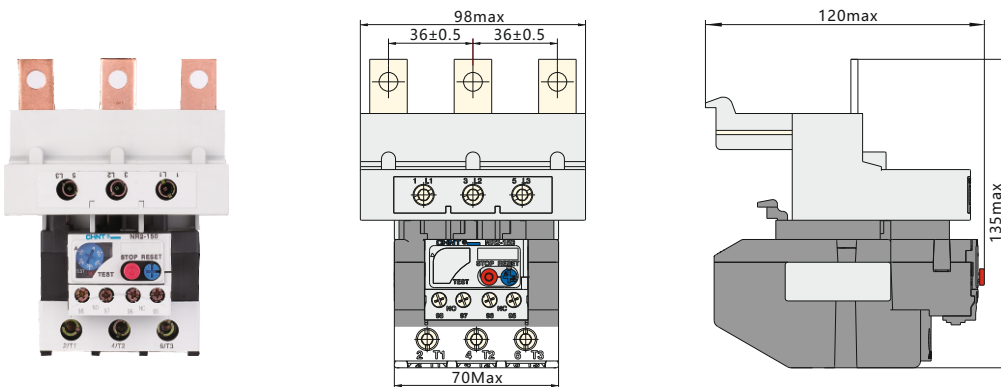

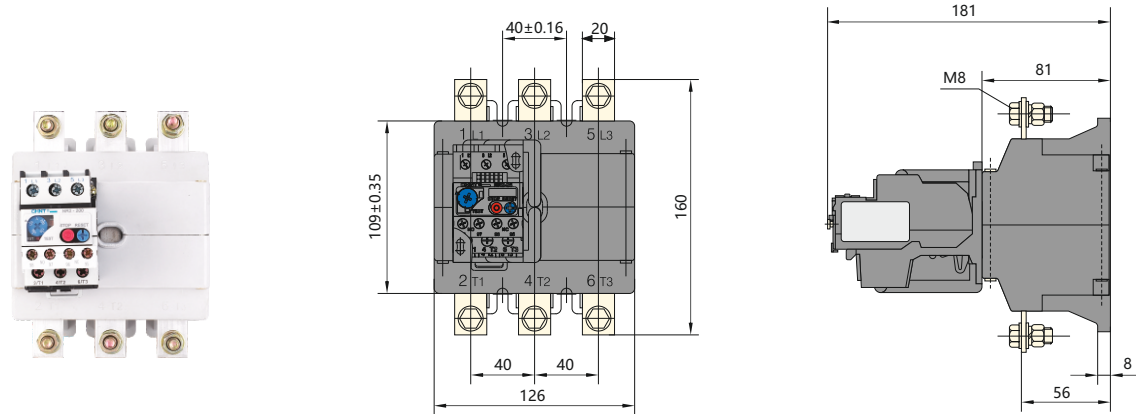

NR2-630

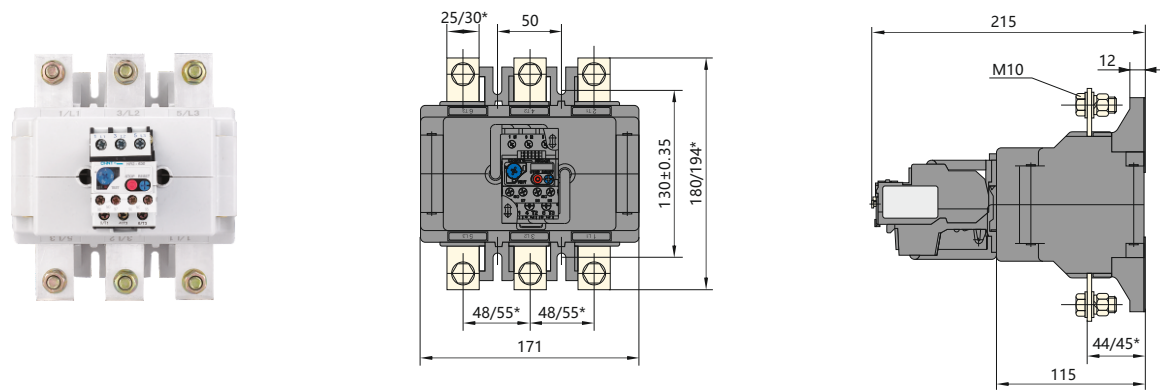





Note: Dimension with "\*" for the product over 400A.



## 6. Wiring







Items			NR2-11.5	NR2-25	NR2-36	NR2-93	NR2-150	NR2-200	NR2-630
Cross section area of conductor mm <sup>2</sup>	Main circuit	Single core or stranded wire	1~4	1~4	4~10	4~35	25~95	25~95	70~2×240
		Wiring screw	M3.5	M4	M4	M10	M6/M8	M8	M10
	Auxiliary circuit	Single core or stranded wire	1~2.5	1~2.5	1~2.5	1~2.5	1~2.5	1~2.5	1~2.5
		Wiring screw	M3.5	M3.5	M3.5	M3.5	M3.5	M3.5	M3.5

### 7. Accessories

No.		Description	Application
1		MB-1	Incorporate with NR2-11.5 relay to form an independently mounted product
2		MB-2	Incorporate with NR2-25 relay to form an independently mounted product
3		MB-3	Incorporate with NR2-36 relay to form an independently mounted product
4		MB-4	Incorporate with NR2-93 relay to form an independently mounted product

### 8. Assembly with contactor

Model of overload relay	Rated current (A)	Recommended fuse type (RT16 is recommended)		Model of contactor
		aM	gG	
 NR2-11.5	0.1~0.16	0.25	2	NC6-09
	0.16~0.25	0.5	2	
	0.25~0.4	1	2	
	0.4~0.63	1	2	
	0.63~1	2	4	
	1~1.6	2	4	
	1.25~2	4	6	
	1.6~2.5	4	6	
	2.5~4	6	10	
	4~6	8	16	
	5.5~8	12	20	
	7~10	12	20	
9~13	16	25		
 NR2-25	0.1~0.16	0.25	2	NC1-09 NC1-12 NC1-18 NC1-25 NC1-32 NC7-09~18 NC7-25~32
	0.16~0.25	0.5	2	
	0.25~0.4	1	2	
	0.4~0.63	1	2	
	0.63~1	2	4	
	1~1.6	2	4	
	1.25~2	4	6	
	1.6~2.5	4	6	
	2.5~4	6	10	
	4~6	8	16	
	5.5~8	12	20	
	7~10	12	20	
9~13	16	25		
12~18	20	35		
17~25	25	50		

Model of overload relay	Rated current (A)	Recommended fuse type (RT16 is recommended)		Model of contactor
		aM	gG	
 NR2-36	23~32	40	63	NC1-32 NC7-32~38
	28~36	40	80	
 NR2-93	23~32	40	63	NC1-40 NC1-50 NC1-65 NC1-80 NC1-95 NC7-40~65 NC7-80~95
	30~40	40	100	
	37~50	63	100	
	48~65	63	100	
	55~70	80	125	
	63~80	80	125	
 NR2-150 (matched with NC2)	80~104	125	200	NC2-115 NC2-150
	95~120	125	224	
	110~150	160	250	
 NR2-150 (matched with NC7)	80~104	125	200	NC7-115 NC7-150 NC7-170
	95~120	125	224	
	110~150	160	250	
 NR2-200	80~125	125	200	NC2-115 NC2-150 NC2-185 NC2-225 NC7-115~170 NC7-205
	100~160	160	250	
	125~200	200	315	
 NR2-630	160~250	250	400	NC2-185 NC2-225 NC2-265 NC2-330 NC2-400 NC2-500 NC2-630 NC7-205~300 NC7-410~475 NC7-620
	200~315	315	500	
	250~400	400	630	
	315~500	500	800	
	400~630	630	800	