

Rodless Pneumatic Cylinder



How to order

ZF	32	B50	FB	SQ	1
Rodless pneumatic cylinder	Bore size	Stroke	Accessories	Sensor type	Number of sensor
ZS : Standard type	18 : φ 18		Blank : W/O accessories	Blank : W/O sensor	1 pc
ZF : Guiding type	25 : φ 25		FB : Mounting bracket	SQ : Square type	2 pcs
ZK : Short type	32 : φ 32		MB : Middle support		
	40 : φ 40		AST : Stop adjustment (shiftable)		
	50 : φ 50		ASF : Stop adjustment (fix)		
	63 : φ 63				









*Please refer to P3-184

Stroke table

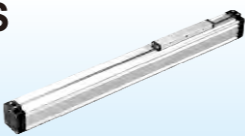
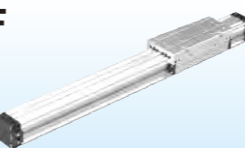
Bore size	Standard stroke (mm)
φ 18~ φ 63	50~6000

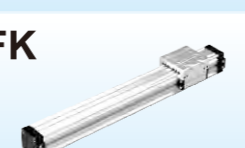
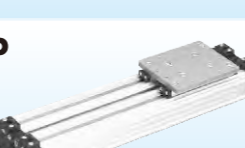
Specifications

Bore size	φ 18	φ 25	φ 32	φ 40	φ 50	φ 63
Port size	M5	G1/8"		G1/4"		G3/8"
Carrying force	140N	270N	440N	680N	1060N	1680N
Cushioning	15mm	18mm	24mm	34mm	40mm	49mm
Cushion	Adjustable					
Stroke	Variable up to 6000mm, option for longer than 6000mm					
Acting	Double acting					
Fluid	Filtered compressed air without lubricant, or slightly lubricated only					
Operating pressure range	2 ~ 8 kgf/cm ²					
Max operating pressure	8 kgf/cm ²					
Lubrication	Not required or few					
Barrel material	Aluminum alloy					
Magnet	Built-in					
Ambient temperature	-20℃ ~ 80℃					
Piston speed	2000mm/Sec(Max)					
Weight of ZS carriage	0.3kg	0.6kg	1.1kg	1.8kg	3.2kg	5.6kg
Weight of ZK carriage	0.2kg	0.4kg	0.7kg	1.2kg	2.0kg	3.2kg
Weight of ZF carriage	0.4kg	0.9kg	1.5kg	2.8kg	4.9kg	8.0kg
Weight of stroke 1000mm barrel	1.5kg	2.6kg	4.8kg	6kg	7.4kg	10kg

Model	Summary	Order
ZS 	ZS Standard cylinder With identical fitting length as existing cylinders without piston. 0-stroke compatible.	Standard
ZF 	ZF Guiding cylinder With external and adjustable slide guide. For high loads.	Standard
ZK 	ZK Short cylinder With extremely shortened fitting length. 0-stroke up to 42% shorter.	Standard
ZFF 	ZFF Guiding cylinder With external and adjustable slide guide. For high loads.	Option
ZFK 	ZFK Guiding cylinder With external and adjustable slide guide. For high loads.	Option
ZP 	ZP Parallel cylinder For high loads and movements in every direction double action force central port.	Option
ZG 	ZG Gripping cylinder Gripping and clamping functions. Opening & closing function.	Option
ZT 	ZT Tandem cylinder For high movements in longitudinal direction.	Option
ZD 	ZD Double action cylinder Double action force pressing, embossing, punching...etc.	Option

Z Series ZS Standard Cylinder

Features

1. High-strength aluminum-extruded section to reduce deflection and increase the slot width.
2. Front and side wipers on the yoke.
3. Grooves in tube profile for fixing various additional components.
4. Fixation at the front can be turned by 4 x 90°.
5. New pin type cushioning.
6. Large clamping surface on the yoke.
7. Guiding over the entire stroke length.
8. One-side connections possible.
9. Torsion-proof.
10. Exchangeable wear parts.
11. High section modulus in all load directions.
12. Adjustable slide guides save additional guiding systems.
13. Carriage can be installed at a later date.

Dimensions

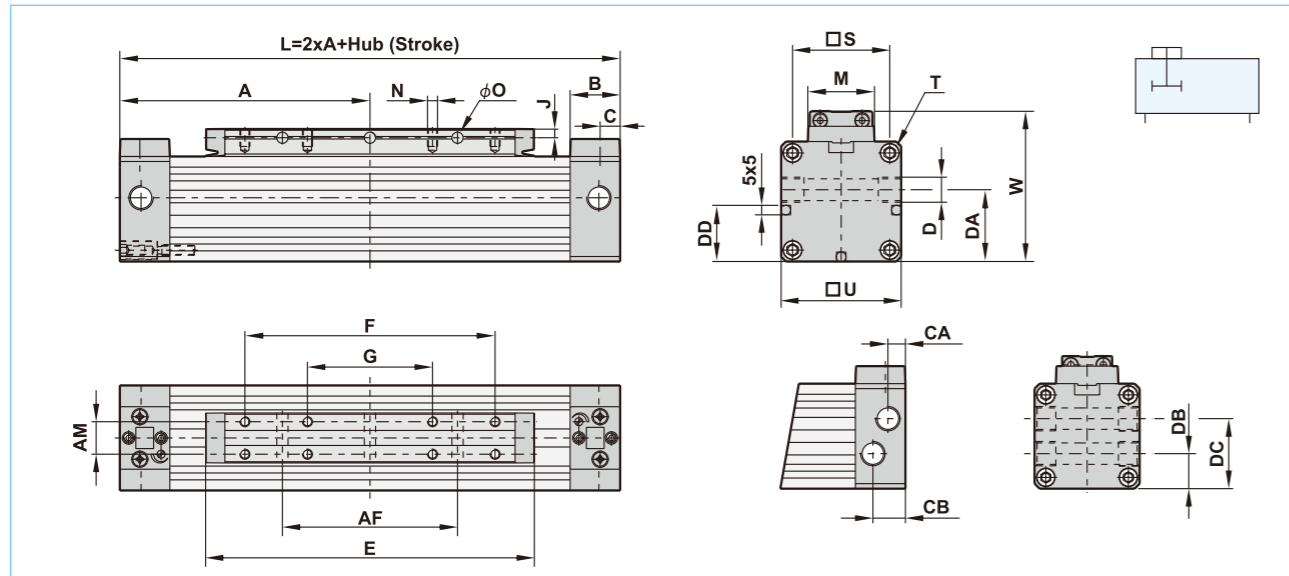

(Unit: mm)

Bore size	A	AF	AM	B	C	CA	CB	D	DA	DB	DC	DD
φ 18	80	50	10	16.5	6.5	—	—	M7x1/6	15.5	—	—	—
φ 25	100	70	13	20	8.5	7	13	G1/8x8	25.5	14	28	18.5
φ 32	120	100	16	20	8.5	7	13	G1/8x8	32	16	34.5	21
φ 40	150	140	22	23	13	11	14.5	G1/4x12	37.5	18.5	41	29.5
φ 50	180	180	29	23	13	12	14	G1/4x12	47.5	22.5	47.5	37
φ 63	215	230	40	29	13	12.5	15.5	G3/8x12	59.5	24.5	59.5	44.5

Bore size	E	F	G	J	M	N	O	S	T	U	W
φ 18	103	75	—	3	15.5	M3x6	3.5	23.5	M3x7	30	39
φ 25	131	100	50	3.5	20	M4x7	4.5	33	M4x9	42	53
φ 32	171	140	70	4.5	25	M5x9	5.5	41	M5x10	52	65
φ 40	220	180	90	5	33	M6x10	7	51	M6x12	63	79
φ 50	280	220	110	6.5	42	M8x12.5	7	63	M8x12	78	96
φ 63	333	280	140	8	54	M8x15	9	78	M8x12	93	113.5

ZF Guiding Cylinder

Features

1. Accuracy and high loading capacity.
2. The cylinder provides V-guide grooves on outer side which support the guide carriage by means of slide bars, the guide carriage is fitted to the sides of the cylinder tube, which means that the increase of the slot width has no influence and can almost be adjusted without backlash.
3. As the guide grooves are integrated into the cylinder tube, the generally complicated and expensive installation of additional guide profiles is eliminated.
4. The adjustable slide bars are made of high-strength plastic. In combination with the anodized surface of the cylinder, these plastic gibs ensure a very favorable sliding effect.
5. Exceptionally compact and space saving.
6. Suitable for lower end supports, center supports, solenoid switch systems.
7. Utilizing cross supports, two guiding cylinders can be connected to form portal support systems with infinitely chosen stroke, which is applicable to variety of applications.
8. Provide highly versatile linear drive element which allows all designers and machine makers to implement future-oriented concepts at reasonable prices.

Dimensions

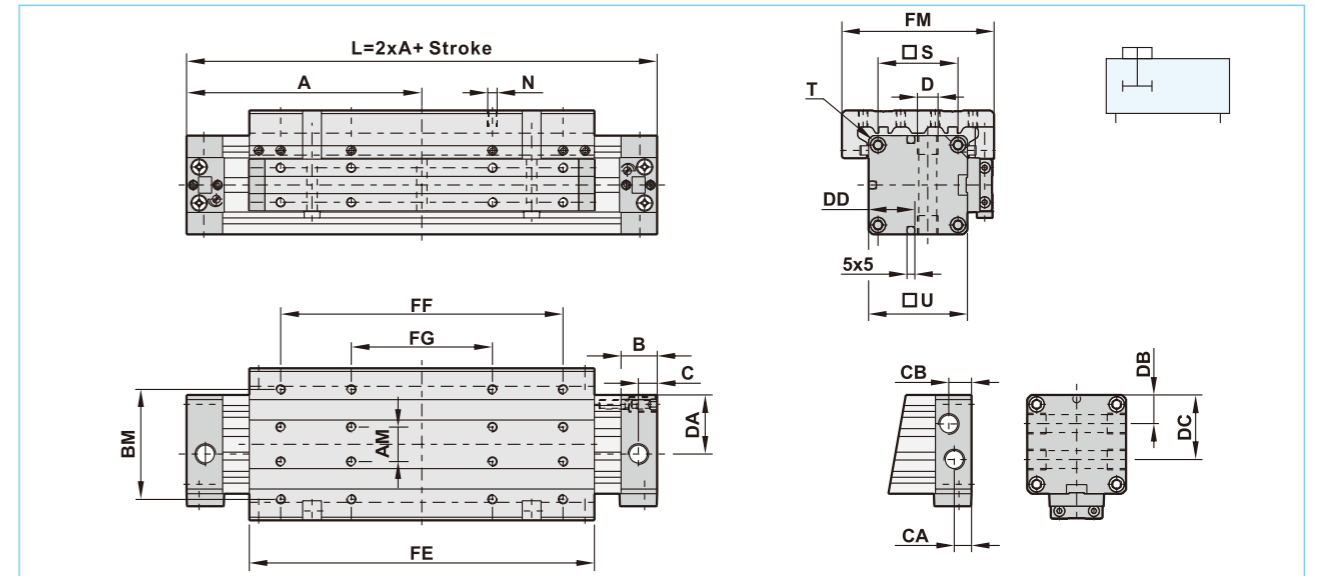

(Unit: mm)

Bore size	A	AM	B	BM	C	CA	CB	D	DA	DB	DC
φ 18	80	10	16.5	35	6.5	—	—	M7x1/6	17.5	—	—
φ 25	100	13	20	45	8.5	7	13	G1/8x8	25.5	14	28
φ 32	120	16	20	55	8.5	7	13	G1/8x8	32	17.5	34.5
φ 40	150	22	24	70	13	9.5	14.5	G1/4x12	37.5	20	42
φ 50	180	29	24	85	13	9.5	14	G1/4x12	47.5	26	52
φ 63	215	40	30	105	13	11	18.5	G3/8x12	59.5	30	62

Bore size	DD	FE	FF	FG	FM	FW	N	S	T	U
φ 18	—	103	75	—	50	39	M4x7.5	23.5	M3x7	30
φ 25	18.5	131	100	50	66	53	M4x8	33	M4x9	42
φ 32	21	171	140	70	80	65	M5x10	41	M5x10	52
φ 40	29.5	220	180	90	97	79	M6x12	51	M6x12	63
φ 50	37	280	220	110	116	96	M8x16	63	M8x12	78
φ 63	44.5	333	280	140	136	113.5	M8x16	78	M8x12	93

Z Series Rodless Pneumatic Cylinder

ZK Standard Cylinder

Features

1. Basic length (0-stroke) up to 42% shorter.
2. Space-saving also in comparison to short-stroke standard cylinders with piston rod.
3. Shorter total fitting length.
4. Money-saving compact construction.



Dimensions

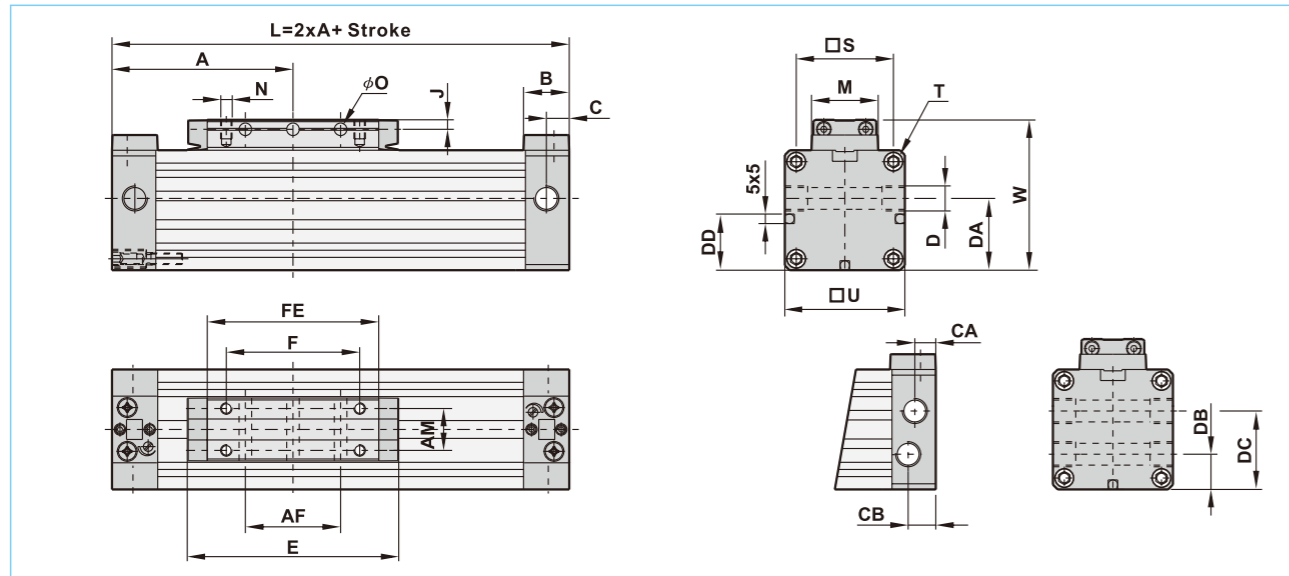

(Unit: mm)

Bore size	A	AF	AM	B	C	CA	CB	D	DA	DB	DC	DD	E
φ 18	57.5	15	10	16.5	6.5	—	—	M7x1/6	17.5	—	—	—	58
φ 25	67.5	19	13	20	8.5	7	13	G1/8x8	25.5	14	28	18.5	66
φ 32	77.5	35	16	20	8.5	7	13	G1/8x8	32	17.5	34.5	21	86
φ 40	95	50	22	24	13	9.5	14.5	G1/4x12	37.5	20	42	29.5	110
φ 50	105	46	29	24	13	9.5	14.5	G1/4x12	47.5	26	52	37	130
φ 63	125	70	40	30	13	11	18.5	G3/8x12.5	59.5	30	62	44.5	153

Bore size	F	FE	J	M	N	O	S	T	U	W
φ 18	30	45	3	15.5	M3x6	3.5	23.5	M3x7	30	39
φ 25	35	51	3.5	20	M4x7	4.5	33	M4x9	42	53
φ 32	55	73	4.5	25	M5x9	5.5	41	M5x10	52	65
φ 40	70	92	5	33	M6x10	7	51	M6x12	63	79
φ 50	70	101	6.5	42	M8x12.5	7	63	M8x12	78	96
φ 63	100	130	8	54	M8x15	9	78	M8x12	93	113.5

Dimension of mounting parts

FB Mounting bracket

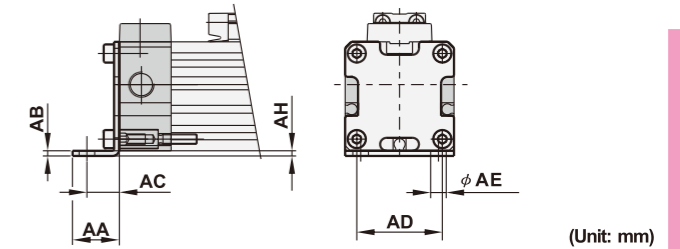
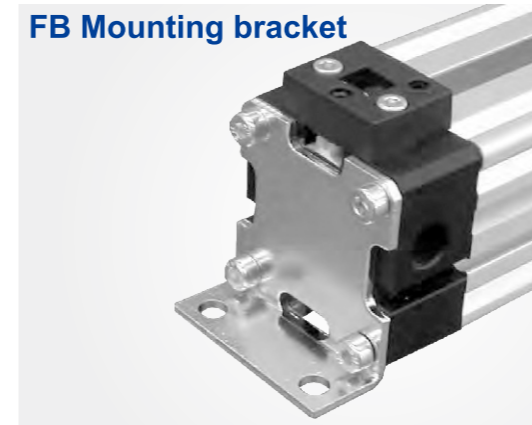

(Unit: mm)

Bore size	Order code	AA	AB	AC	AD	AE	AH
φ 18	1182-0001	15	2	10	20	6	2
φ 25	1252-0001	18	2	12.5	30	6	2
φ 32	1322-0001	20	2.5	13.5	40	7	3
φ 40	1402-0001	30	3	17.5	50	9	3.5
φ 50	1502-0001	28	3	20	60	9	3
φ 63	1632-0001	30	3	21	75	11	4.5

MB Middle support

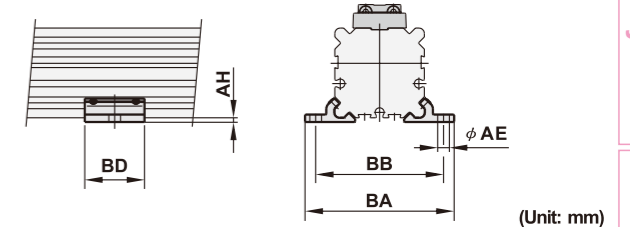

(Unit: mm)

Bore size	Order code	AE	AH	BA	BB	BC	BD	BE	BF
φ 18	1183-0001	6	2	56	46	36.5	23	2.5	8.25
φ 25	1253-0001	6	2	70	60	50	28	3.5	11
φ 32	1323-0001	7	3	85	73	61.5	33	4	13.8
φ 40	1403-0001	9	3	105	90	75	38	4.5	16
φ 50	1503-0001	9	3	122	106	91	43	5	19
φ 63	1633-0001	11	4.5	144	125	107	48	6	22

Mounting example for MB middle support

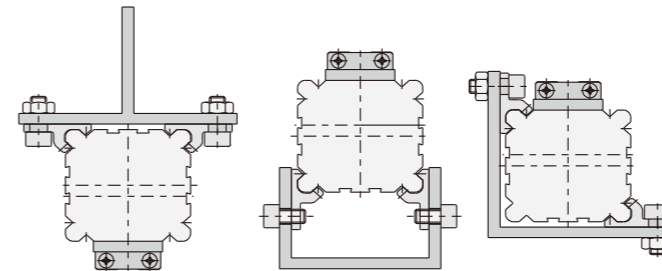

Deflection diagram

When using very long cylinders or applying heavy loads, the tube deflection is to be taken into consideration. One or more middle supports are to be used according to the admissible deflection.

Example:
A cylinder φ 25 should deflect by a maximum of 0.5mm when applying a force Fz of 500N. According to the diagram the cylinder can be 750mm long. Longer cylinders must have a middle support.

Other possibilities
In case very long cylinders are installed without supports, and additional profile can be used as a support.

Examples: all versions with middle support and standard profiles.

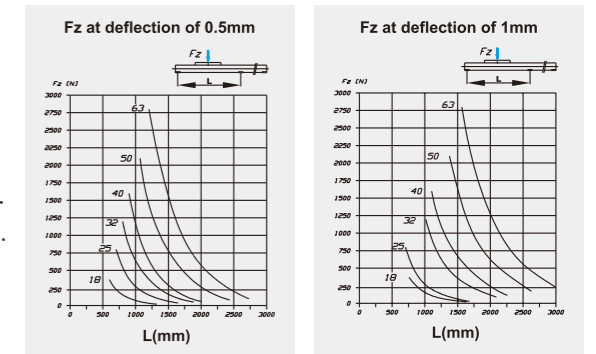

Z Series Rodless Pneumatic Cylinder

AS Stop adjustment

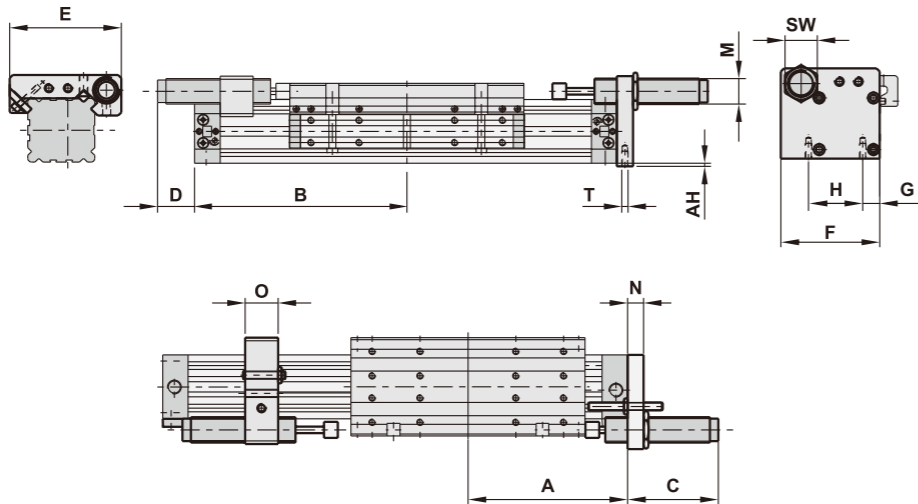
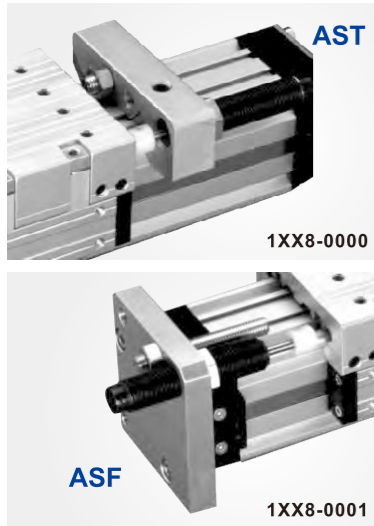

(Unit: mm)

Bore size	Order code	A		B		C	D	E	F	G	H	M	N	O	SW	T	Shock absorber	
		ZF	ZFK	AH	ZF													ZFK
φ 18	1188-0000 1188-0001	80	57.5	2	113	90.5	32	Max25	57	43.5	8	23.5	M10x1.0	8	15	13	M3x10	DA1008-HP
φ 25	1258-0000 1258-0001	100	67.5	2	117.5	85	37	Max40	72	57	12.5	33	M14x1.5	10	20	17	M4x10	DA1415-HP
φ 32	1328-0000 1328-0001	120	77.5	3	135.5	90	70	Max30	84	70	14.5	41	M14x1.5	12	20	17	M5x12	DA1415-HP
φ 40	1408-0000 1408-0001	150	95	3	165	110	65	Max50	105	93	16	51	M25x1.5	15	30	32	M6x15	DA2525-HP
φ 50	1508-0000 1508-0001	180	105	3	195	140	80	Max65	126	102	22.5	63	M25x1.5	15	30	32	M8x20	DA2525-HP
φ 63	1638-0000 1638-0001	215	125	4.5	250	160	80	65	140	118.5	20	78	M25x1.5	15	40	32	M8x20	DA2525-HP

Shock absorber is available in case of enquiry.

Repair kits

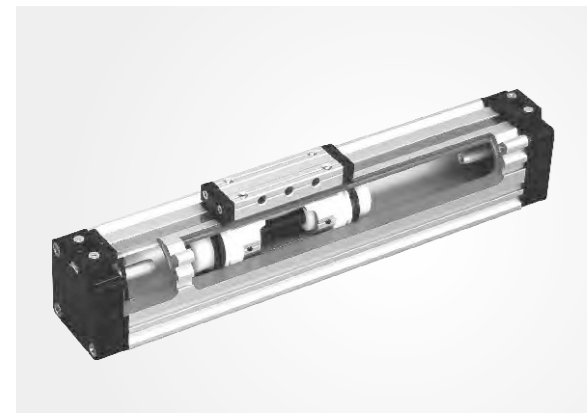

Bore size	ZS	ZK	ZF
φ 18	ZS-1189-0000-□□□□	ZS-2189-0000-□□□□	ZS-3189-0000-□□□□
φ 25	ZS-1259-0000-□□□□	ZS-2259-0000-□□□□	ZS-3259-0000-□□□□
φ 32	ZS-1329-0000-□□□□	ZS-2329-0000-□□□□	ZS-3329-0000-□□□□
φ 40	ZS-1409-0000-□□□□	ZS-2409-0000-□□□□	ZS-3409-0000-□□□□
φ 50	ZS-1509-0000-□□□□	ZS-2509-0000-□□□□	ZS-3509-0000-□□□□
φ 63	ZS-1639-0000-□□□□	ZS-2639-0000-□□□□	ZS-3639-0000-□□□□

How to order

ZS — **1189-0000** — **0100**

ZS Standard cylinder	Bore size	Stroke
	φ 18 φ 40	
	φ 25 φ 50	
	φ 32 φ 63	

Details included

No.	Description	Qty.
1	Round profile/m	1
2	Sealing strip/m	1
3	Cover strip(Steel)/m	1
4	Head wiper	2
5	Wiper	2
6	Guiding bar	2
7	Piston seal	2
8	Cushion ring	2
9	End cap O-ring	2
10	Cushion pin O-ring	2
11	Cylinder head screw plain ISO4762	4

Loads

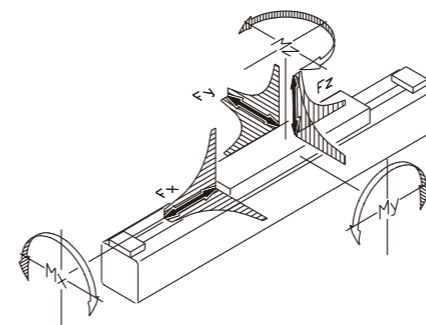

$$\Sigma F = F_{zul} = \sqrt{F_x^2 + F_y^2 + F_z^2}$$

Note:

All data concerning forces and torques refer to a speed of $V < 0.35m/s$.
Observation keeping the indicated values ensures maximum service life, minimum noise and optimum noise and optimum operating results.
Higher speeds reduce the admissible forces.

ZS Standard cylinder

Piston	$V_{max} \leq 0.35m/s$			Admissible loading force (Fzul)			Torques		
	Fx(N) Acting force of 6 bar	Fy(N)	Fz(N)	0.75 m/s	1 m/s	1.5 m/s	Mx(Nm) Fy/Fz	My(Nm) Fx/Fz	Mz(Nm) Fx/Fy
φ 18	140	80	300	80	40	20	1	3	3
φ 25	270	110	480	155	90	40	2	13	13
φ 32	440	165	650	280	155	70	3.5	25	25
φ 40	680	225	800	500	290	125	5.5	40	40
φ 50	1060	325	1060	790	420	195	10	65	65
φ 63	1680	435	1680	1500	850	370	16	100	100

ZK Short cylinder

Piston	$V_{max} \leq 0.35m/s$			Admissible loading force (Fzul)			Torques		
	Fx(N) Acting force of 6 bar	Fy(N)	Fz(N)	0.75 m/s	1 m/s	1.5 m/s	Mx(Nm) Fy/Fz	My(Nm) Fx/Fz	Mz(Nm) Fx/Fy
φ 18	140	40	300	80	40	20	0.4	0.7	0.7
φ 25	270	55	230	90	50	25	0.7	2.7	2.7
φ 32	440	70	320	200	110	45	1	5	5
φ 40	680	100	400	420	240	110	2	8.5	8.5
φ 50	1060	140	480	750	440	190	3.5	13	13
φ 63	1680	180	590	1500	850	380	50	18	18

ZF Guiding cylinder

Piston	$V_{max} \leq 0.35m/s$			Admissible loading force (Fzul)			Torques		
	Fx(N) Acting force of 6 bar	Fy(N)	Fz(N)	0.75 m/s	1 m/s	1.5 m/s	Mx(Nm) Fy/Fz	My(Nm) Fx/Fz	Mz(Nm) Fx/Fy
φ 18	140	370	370	100	58	26	3.5	6	6
φ 25	270	800	800	280	160	65	10	20	20
φ 32	440	200	200	510	300	140	25	45	45
φ 40	680	1600	1600	1000	550	250	40	75	75
φ 50	1060	2100	2100	1500	850	380	80	150	150
φ 63	1680	2800	2800	2500	1400	610	110	250	250

Controls

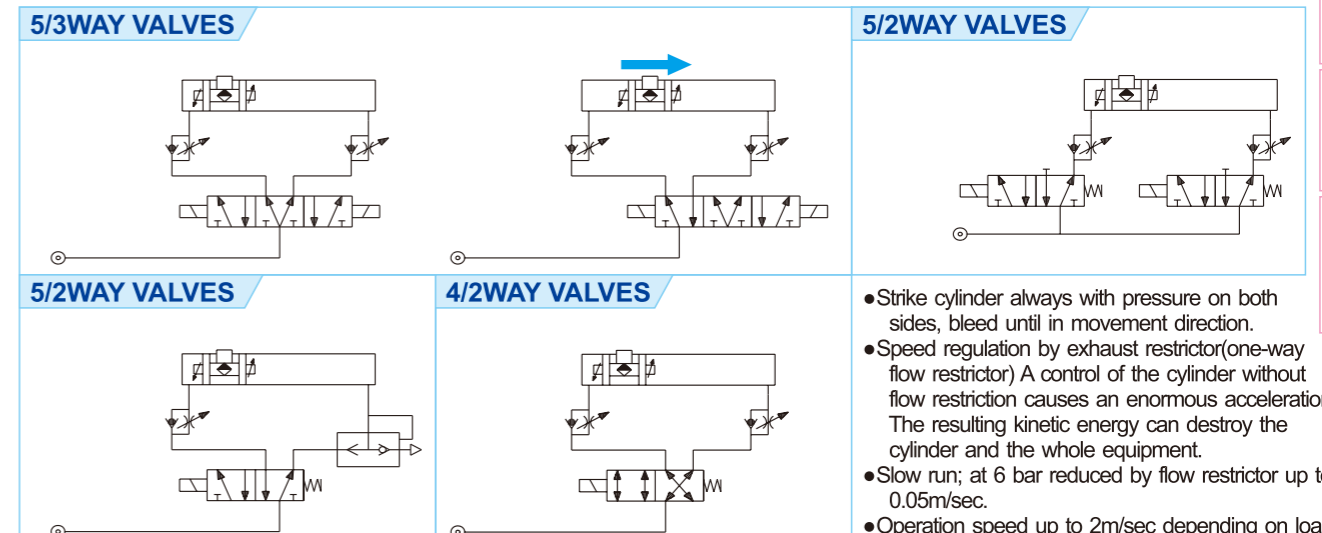

Z Series *Rodless Pneumatic Cylinder*
Sensor Switch

Material of parts

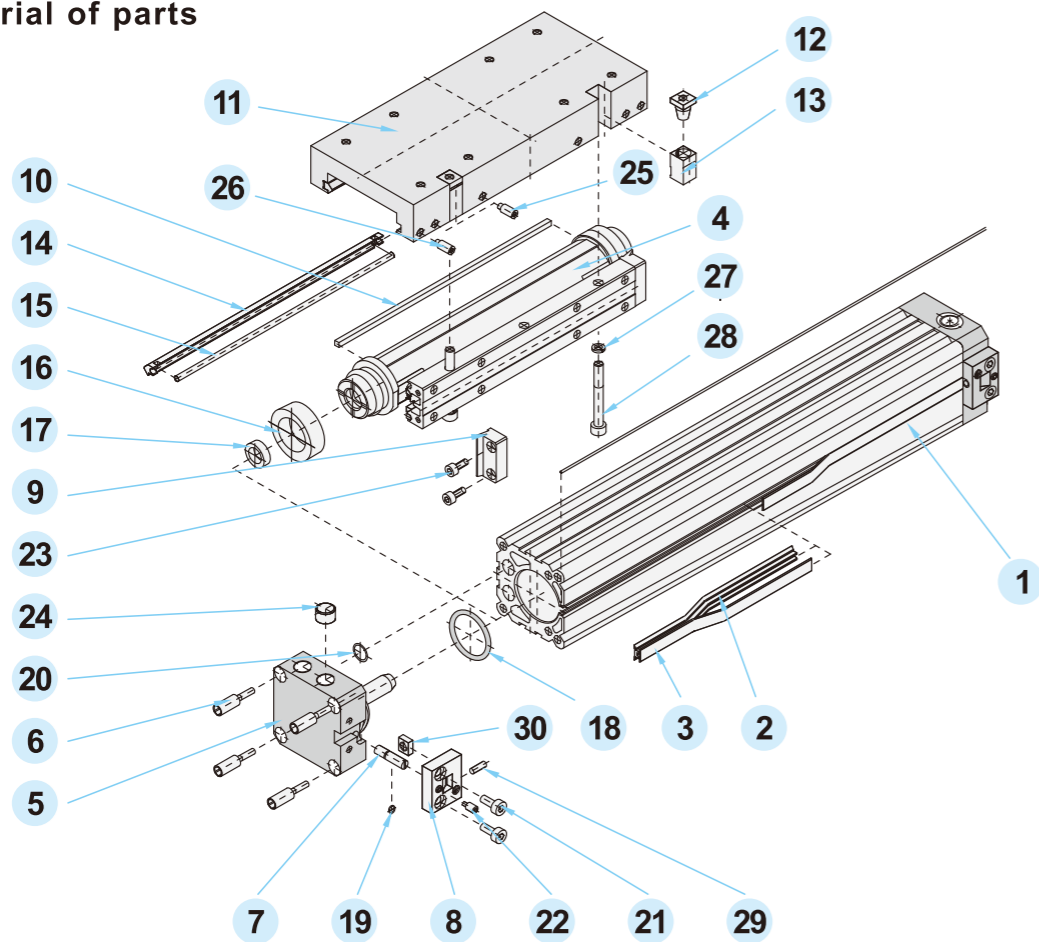

No.	Description	Material	No.	Description	Material
1	Tube	Al anodized	16	Piston seal	PU
2	Sealing strip	PU	17	Cushion ring	NBR
3	Cover strip	Stainless steel	18	O-ring	NBR
4	Yoke	Al anodized/POM	19	O-ring	NBR
5	End cap	Al anodized	20	Flat seal	NBR
6	Special screw	Zinc-plated steel	21	Countersink screw	Zinc-plated steel
7	Cushioning pin	Stainless steel	22	Grub screw with pin	Zinc-plated steel
8	Strip cover	POM	23	Cylinder head screw	Zinc-plated steel
9	Head wiper	POM	24	Plug screw	Zinc-plated steel
10	Wiper	POM	25	Grub screw	Browned steel
11	Carriage	Al anodized	26	Grub screw with pin	Browned steel
12	Cone nut	Zinc-plated steel	27	Plain washer	Zinc-plated steel
13	Clamp wedge	Al anodized	28	Cylinder head screw	Zinc-plated steel
14	Guiding bar	POM	29	Grub screw	Browned steel
15	Press bar	Stainless steel	30	Square nut	Zinc-plated steel

Memo...

Blank area for notes with horizontal dashed lines.

