

# ES series cluster driver Hardware manual

F0 serial driver module(0.37 to 4.0 kW)

F1 and the above series driver module(380V~series0.37to630 kW)  
(660/690V~ series4.0to1250 kW)

Other series in accordance with the machine model



**CUMARK**

## ✓ Quick operation guide

In the process of installation and debugging, Please be sure to follow the quick guide operate, And complete the following steps operate. If there be any problem, Please contact your local dealer or our representative.

### Steps are as follows:

1. Check for drive size and shape model, check the nameplate labels are consistent with the order, see page 16 nameplate interpretations.
2. Before you do any debugging, please read the safety procedures in the first chapter, see 2- 4 pages.
3. Mechanical before installation, please check the drive according to chapter 3 page 14 shows the external environment condition and minimum space around.
4. According to chapter 8 page 34, install the motor cable, main power cable, the specifications of the mains fuse and cable connection.
5. According to the instructions in chapter 3, installed cabinet put oneself in another's position and mechanical design and implementation.
6. According to the instructions in chapter 4 installed in electrical design and implementation.
7. If the startup wizard is activated, you should select the panel language and apply the macro and confirm it.
8. All the parameters have the default factory set value. In order to ensure the correct operation, please check the following parameter value data on the nameplate and the corresponding parameters in the group:
  - ✓ Motor rated voltage
  - ✓ Motor rated frequency
  - ✓ Motor rated speed
  - ✓ Motor rated current
  - ✓ Motor rated power
9. According to chapter 6 on page 29 of the checklist check up, in accordance with the instructions manual firmware to debug.
10. At this point, you can start using this driver.

**Shall not be responsible for any loss caused by the violation of the above-mentioned operation procedures and the requirements of the relevant standards.**

©2017Shenzhen cumark new technology co,ltd.  
Copyright

## ■ About this manual

Congratulations and thank you for choosing the motor drive control provided by the CUMARK series drive!

This manual will provide you with the necessary information about the installation, commissioning and operation of the drive. It is applicable to the design, installation, commissioning, use and maintenance of the engineering and technical personnel.

This series driver is our company's latest high reliability, high performance, multi function, intelligent AC motor drive.

The drive has the characteristics of stable, reliable, intelligent, easy usage and so on. This manual contains the basic technical parameters of the drive, mechanical & electrical installation, wiring, maintenance, the content related operating methods and matters needing attention. On the control and drive function operation and its parameter setting, please refer to the **【Firmware Manual】**.

In order to ensure that you are able to use this series, getting the full excellent performance of the product and ensure the safety of the user and equipment. Please read this manual carefully before starting the operation of the drive. At the same time, the reader should have basic knowledge of electrical, wiring, electrical components and electrical schematic symbols, etc. Incorrect use may cause the drive to run an exception, a failure, even equipment damage, personal injury and other accidents!

This manual is an accessory in package. Please properly keep. As strong product features, in order to enhance the applicability of the drive, in this paper, the drive instead of frequency converter and other common words are described.

As we always focus on the continuous progress and improvement of products and related information, Therefore, the information provided by the company if there is any change, Without prior notice.

The latest changes and more content, Please contact our local representative office or visit our website directly.

## ■ 1. Safety instruction

This chapter describes the safety instructions for the installation, operation, and maintenance of the drive. Ignoring these safety instructions may cause personal injury or damage to the motor and its drive. Please read the safety instructions before you do any operation on the device.

### Warnings and pay attention to the instructions

This manual contains 5 types of safety instructions:



**Dangerous voltage warning:** used to warn of the presence of high voltage, which may cause personal injury and / or damage to equipment.



**Dangerous voltage warning:** Used to warn the device within 10 minutes after the main power cut will continue to exist in the presence of high voltage, may cause personal injury and / or damage to equipment.



**General warning:** Used to warn of non electrical factors that may cause personal injury and / or damage to equipment.



**Electrostatic discharge warning:** Used to warn of electro static discharge that can cause damage to equipment.

**Surface high temperature warning:** Used to warn the parts of the surface temperature, exposure will cause burns.

### Electrical installation must be completed by professional personnel

## Installation and maintenance

The following warnings apply to people who need to install and maintain a motor cable or motor.



**Warning !** Ignore these safety instructions may cause personal injury or damage to the equipment Only a qualified electrical engineer is allowed to install and maintain the drive.

In the case of main power on, it is not allowed to maintain drive, motor cable or motor. After disconnecting the power, must wait at least 10 minutes before operating the drive, the electric motor or the electric cable, so that the DC circuit capacitor is discharged.

### Confirm by the universal meter measurement (The resistance is at least 1 MΩ):

1. For the three-phase of the drive, input terminals R, S and T or ( L1/L2/L3), there is no voltage between either of the three and the ground.
2. DC bus UDC+ and UDC- is Zero voltage to ground.
3. PB, + and – is Zero voltage to ground.

● **Drive for control of permanent magnet motor:** The rotating permanent magnet motor feeds the power supply to the driver, even when the motor stops and cut off the power supply, the drive will be charged. Before carrying out maintenance work on the drive, please

- Disconnect the motor from the drive by a safety switch.
- Prevent any other motor starting from the same mechanical system
- Lock motor spindle
- Measurement of the motor to confirm that it has no electricity, and then drive the U, V and W terminals connected to each other and connected to the PE.

● When the driver or external control circuit is powered, do not operate on the control cable. Even if the power supply has been cut off, the control circuit which is supplied by the external power supply will also introduce the dangerous voltage into the drive.

● Do not carry on any insulation or the withstand voltage test to the drive or the drive module.

● For the IT power supply system (ungrounded power system or with high resistance (more than 30 ohms) grounding power system) installed on the drive, if the piezoresistor or the internal EMC filters does not disconnected, then the drive will be grounded by the piezoresistor / filter. This may cause damage to the drive.

● For a drive installed on the TN system with an angle to the ground, the drive will be damaged if the piezoresistor or or internal EMC filter is not disconnected.

## Pay attention to the dangerous voltage

- Even if the motor has been stopped, the circuit terminals R, S, T and V, U, W, and UDC-, UDC+, and PB are still possible with a dangerous voltage.
- Depending on the external connection, the drive control unit on the relay output terminal may be dangerous voltage (115V, 220 V or 230 V).
- Drive support for "security torque interrupt" function. See **firmware manual** for details.



### **Warning! Ignore these safety instructions may cause personal injury or equipment damage.**

- Can not directly repair the drive. Do not attempt to repair a faulty drive on the spot; please contact the local representative office or authorized repair center for replacement.
- At the time of installation, must ensure that the conductive dust produced by drilling did not enter inside the drive. The conductive dust cabinet may cause damage or drive failure.
- Ensure that the drive is fully cooled.



### **warning! The printed circuit board contains elements that are sensitive to the electrostatic discharge. When processing the circuit board, make sure to wear the ground bracers to avoid the unnecessary contact to the circuit board.**

## Start and run



These warnings are applicable to the engineering and technical personnel s who design the operating procedures of the drive, start or operate the drive.

### **Warning! Ignore these safety instructions may cause personal injury or equipment damage.**

- Before you debug or use the drive, you must ensure that the motor and its drive device can operate normally within the entire speed range of the drive. The drive can be adjusted to allow the motor to run at a speed higher or less than the rotation speed obtained from connecting the motor directly to the power grid.
- If there is a danger, do not activate the standard application of automatic fault reset function. Active this function if fault occurs, the drive will be reset and run.
- Do not use the AC contactor or circuit breaker (open circuit) to control the motor. Instead, use the control panel or the control command of the drive I/O board or the field bus adapter to control the drive. The maximum number of charging cycles (i.e., by applying a power supply) to the DC capacitor is once every two minutes. For the size of the F0-F3 series models, the total maximum charge is 100000 times, for the size of F4 and above series models the figure is around 50000 times.
- **Control of the permanent magnet motor:** Do not exceed the rated speed to run the motor. Excessive motor speed may lead to over voltage, thereby permanently damage the drive.

### **attention:**

- If choose the external signal source as start command, and the signal source in ON (start) status, the driver will start immediately after the fault reset unless the drive configured into 3 lines (pulse) macro start / stop.
- When the drive control position is not set in local, the stop button on the keyboard will not stop the drive.



### **Warning! When the system is in use, the surface of the drive system components (e.g. the exposed radiator, the input reactor and the braking resistance in use) will produce high temperature. Do not touch, otherwise there is a risk of burns!**

## Catalog

■ About this manual .....	1
■ 1.Safety instruction .....	2
Installation and maintenance .....	3
Pay attention to the dangerous voltage.....	4
Start and run.....	4
■ 2.The Operating Principle and Hardware Description .....	7
Product Overview and Layout.....	8
The Control Unit Interface and Layout.....	9
Introduction to the Control Keyboard Layout and the Interface.....	10
【The firmware manual】 . .....	10
F1 and the above Series Standard System Wiring Diagram(Sample) .....	11
F0 Series Standard System Wiring Diagram (sample) .....	12
■ 3.Cabinet and Mechanical Installation Design .....	13
Cooling and Protection Grade .....	14
Configuration and Mechanical Installation Size .....	15
Preparation work before the installation.....	16
Installation steps .....	16
■ 4.Electrical installation design.....	17
Thermal Overload and Short Circuit Protection .....	18
Power Cable Selection.....	19
Control Cable Selection .....	22
cabling .....	22
■ 5.Electrical Installation .....	24
Check insulation.....	25
Connection procedure .....	26
Schematic and installation instructions for each type of structure .....	28
DC Bus Connection .....	29
■ 6.Installation Check list .....	30
Mechanical installation check list .....	30
Electrical installation check list .....	30
■ 7.Maintenancec.....	31
Summary of daily maintenance and maintenance.....	31
Sink maintenance and cleaning.....	32
Cooling Fan .....	33

6----- Hardware manual----

Capacitor Charging.....	34
Other maintenance operations .....	34
■ 8.Technical Data .....	35
Rated Value/Codenserfanflowrete/ noise level .....	35
Derating .....	36
Main technical data and specifications .....	37
Power cable size and fuse.....	40
Material introduction .....	41
■ 9.EMCElectromagnetic Compatibility Guide andCE mark .....	42
Electromagnetic compatibility definition .....	42
EMCfilters.....	44
■ 10.Input reactor .....	45
■ 11.du/dt and common mode filtering .....	46
■ 12.Resistance Brake .....	47
Brake chopper and resistor .....	47
Resistance installation and connection .....	48
Driver the Contactor Protection .....	49
Brake Circuit Debugging.....	49
■ 13.Dimensional Drawing.....	50
Control keyboard and bracket shape and the installation dimensions .....	50
F0 Outline and Size Chart .....	51
F1,F2,F3 Outline and Size Chart.....	52
F4 Outline and Size Chart .....	53
F5 Outline and Size Chart .....	54
F6 Outline and Size Chart .....	55
F7 Outline and Size Chart .....	56
F8 Outline and Size Chart .....	57
F9 Outline and Size Chart .....	58
■ More Information.....	61
Product and Service Consulting .....	61
Provide Feedback on this Manual .....	61



## ■ 2.The Operating Principle and Hardware Description

The hardware principle of the drive peripheral and ontology is summarized as: The three-phase AC reactor at the side of the main power supply or a built-in DC reactor and DC link capacitor together, constitute the LC filter, coupled with the diode bridge constitutes the DC voltage source required by an IGBT inverter bridge module. Another function of the AC reactor is to suppress the high frequency disturbances from the power supply to the drive or from the internal of the drive to the power side. At the same time improve the input current waveform of the drive. This makes the power absorbed from the power side by the drive is almost active power. The IGBT bridge produces a symmetrical three-phase AC PWM voltage acting on the motor. The built-in microprocessor controls the motor according to the test signal, the parameter setting value and the command from the control I/O module and the control keyboard. The control unit module in the drive sends a command to the motor control customized integrated circuit, which calculates the IGBT switch position, and the gate drive amplifies the signals to drive the IGBT inverter bridge. In order to express with more details for the general requirements for the design and implementation of an automatic drive and control system for the protection, efficiency and reliability of the drive, now will this drive and its peripheral standard configuration and connection relationship mapping indicated as below:

Figure2-1 Standard Connection Diagram of the Drive and Its Periphey

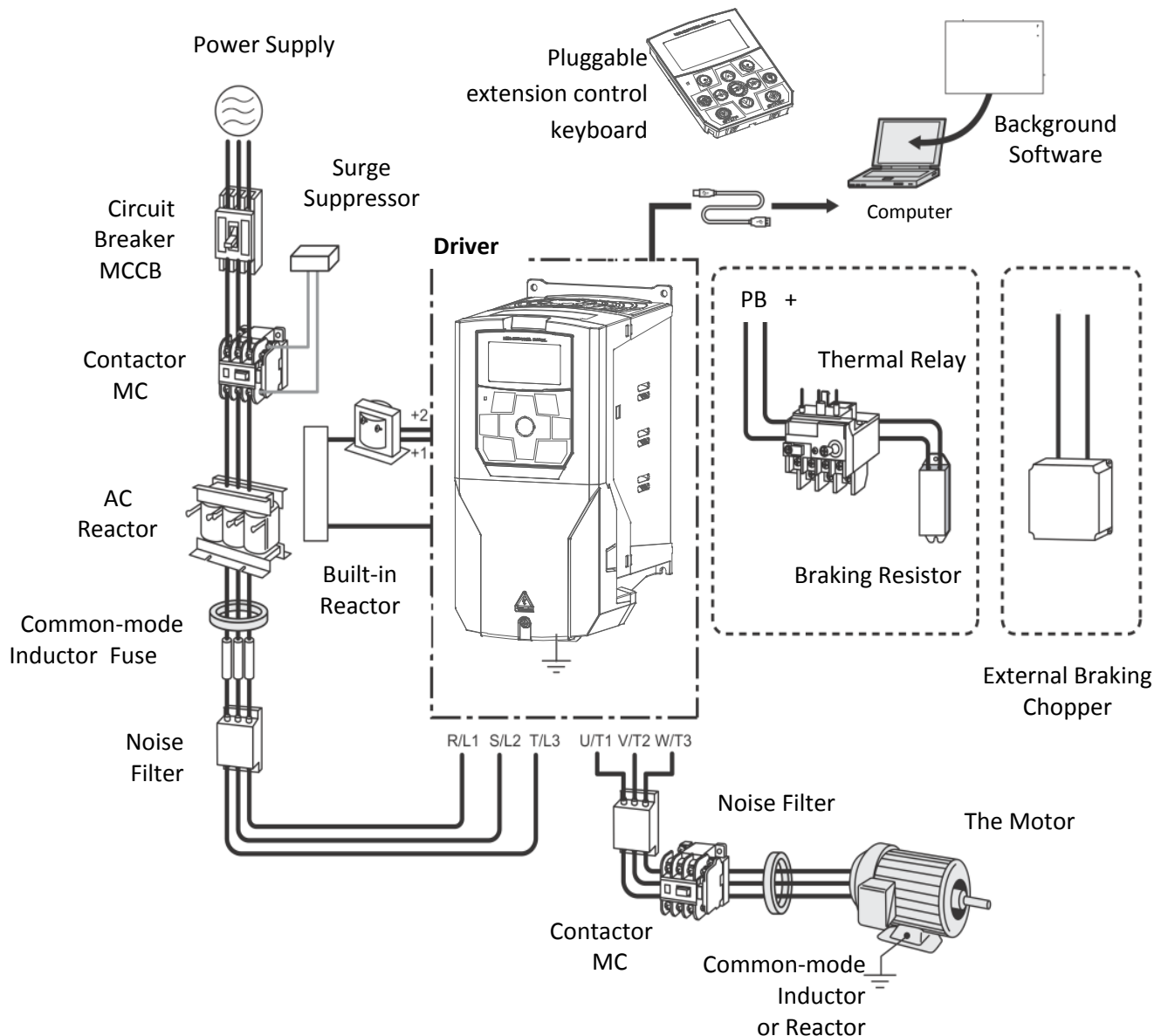

## 2. The Operating Principle and Hardware Description

## Product Overview and Layout

The below figure takes F1 shape and volume and its terminal part as example for introduction (other shapes and volumes please refer to the size chart and products in kind)

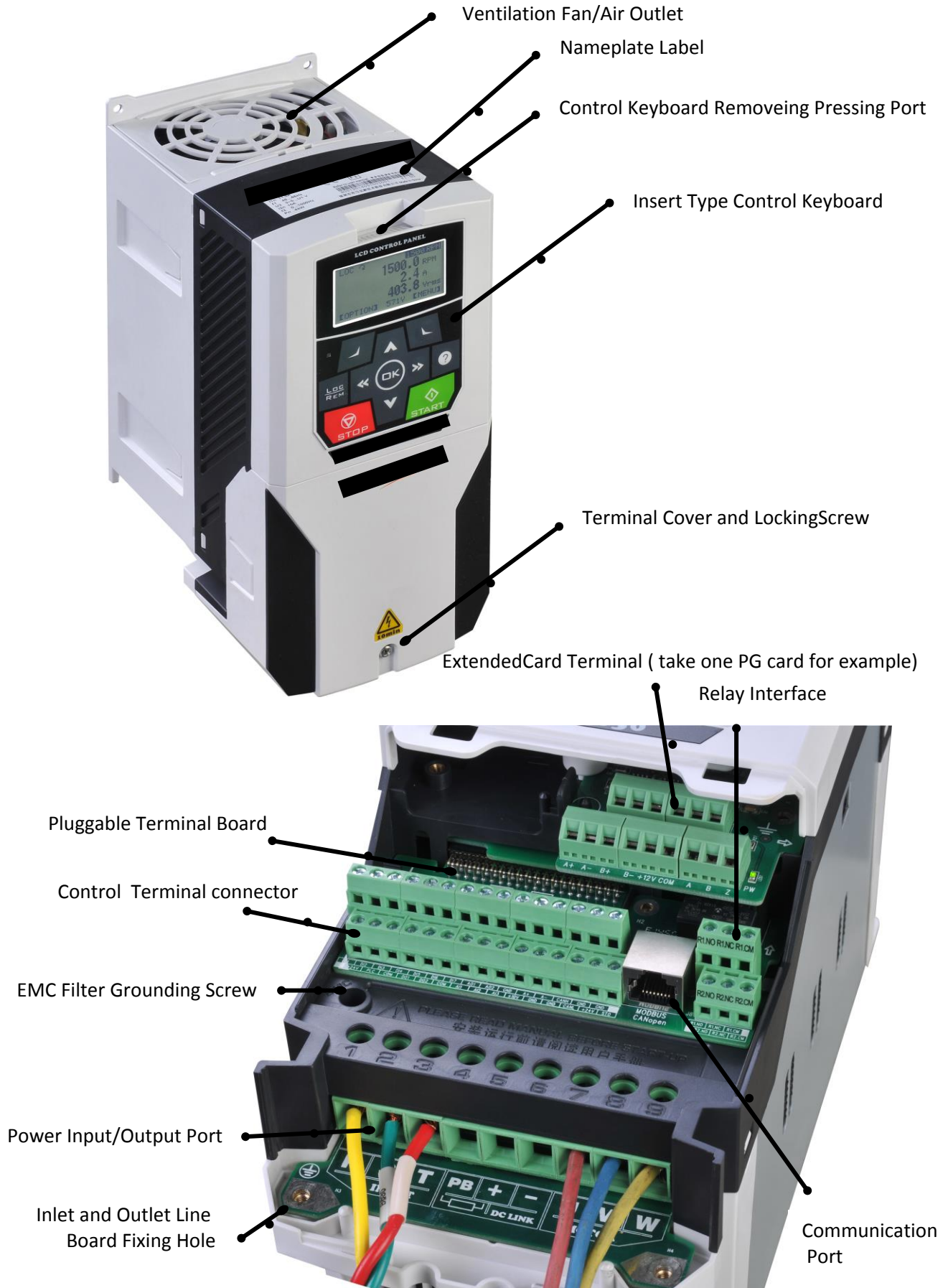

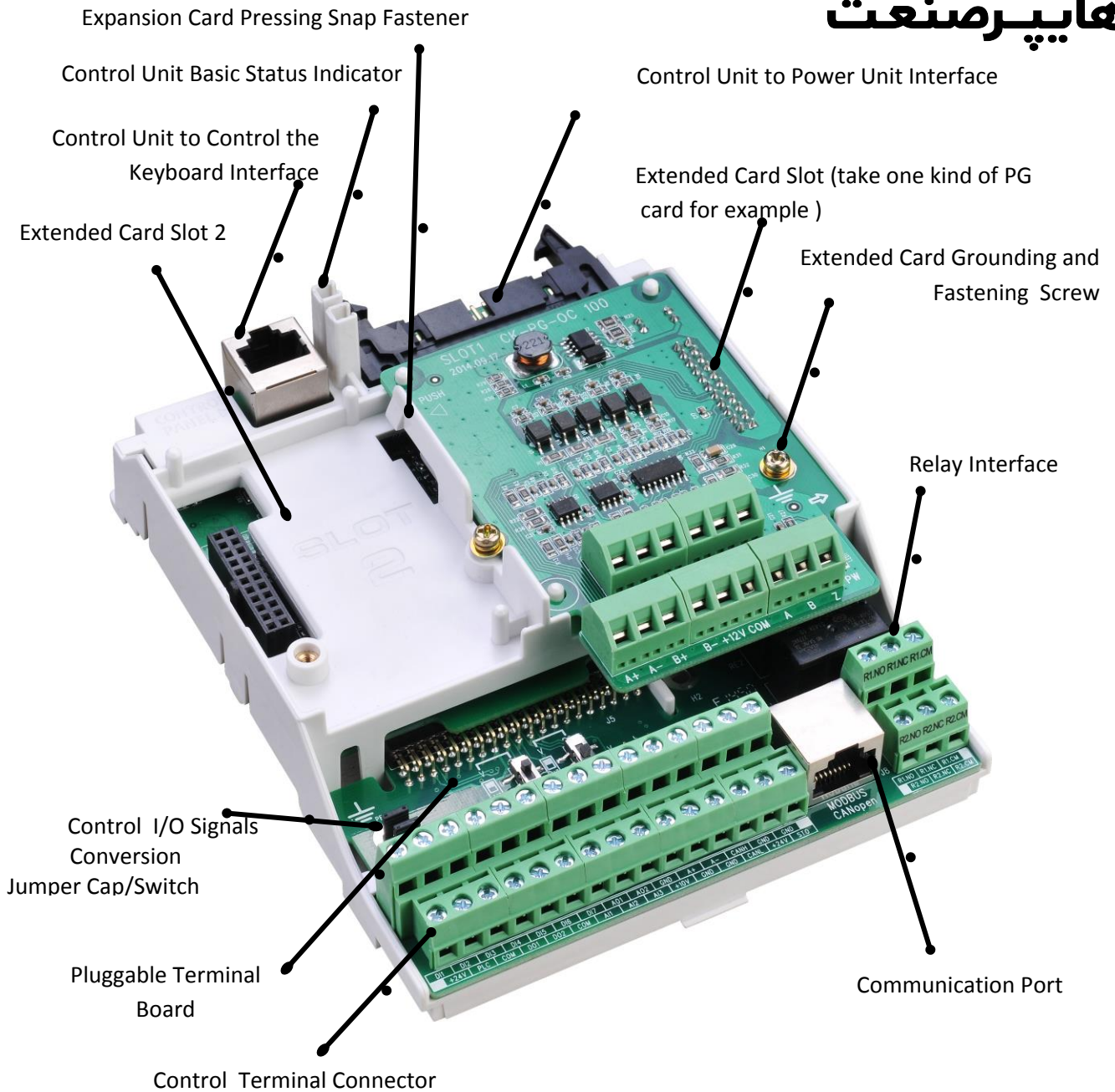

## 2. The Operating Principle and Hardware Description

# The Control Unit Interface and Layout



 [www.famcocorp.com](http://www.famcocorp.com)  
 E-mail: [info@famcocorp.com](mailto:info@famcocorp.com)  
 @famco\_group

 Tel: ۰۲۱-۴۸۰۰۰۰۴۹  
 Fax: ۰۲۱-۴۴۹۹۴۶۴۲

تهران، کیلومتر ۲۱ بزرگراه لشگری (جاده مخصوص کرج)  
 رو بروی پالایشگاه نفت پارس، پلاک ۱۳

## Introduction to the Control Keyboard Layout and the Interface

The control keyboard can be used to control the drive, read the status data and parameters. Below is a brief introduction of the most widely used LCD control keyboard functions and operations. For LED keyboard and more functions and operation instructions, please refer to

【The firmware manual】.

### Characteristics

- Control keyboard equipped with LCD display text, digital and graphic multiple display.
- Parameters can be copied to the control keyboard memory, so that these parameters can be transmitted to other drivers in the future, or for a specific system backup.
- Rich text tips and help.
- Real-time monitoring of the driver DC bus voltage.

### Layout Diagram

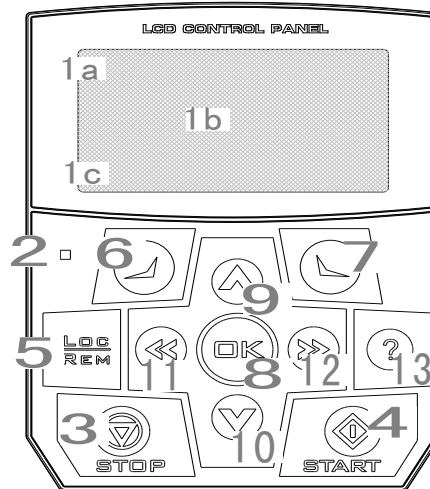

### Basic Status Information Drive displayed on the Top of the LCD



Serial Number	Field	Options	Implications
①	The Controlling Position	LOC	Drive is in local control mode, that is, control by controlling the keyboard.
		REM	Drive is in remote control mode, control via the I/O port or field bus.
②	Status	↻	Drive to stop, the starting direction is positive.
		↺	Drive to stop, the starting direction is reverse.
		Rotation Arrow	Drive runs, the output equals to the given range.
		Dotted Line Rotation Arrow	Drive runs, the output differs from the given range.
		Static Arrow	Drive runs, the output equals to 0.
Empty	Running is prohibited, e.g. drive under voltage, no start signals, etc.		
③	Control Keyboard Operation Mode		<ul style="list-style-type: none"> <li>• Name of the Current Mode.</li> <li>• Name of the displayed menu, list, or text</li> </ul>
④	Number of a Given Value or Selected Item		<ul style="list-style-type: none"> <li>• Display the given value after returning to the main interface.</li> <li>• Showing the number of selected items after entering the menu, for example, the code of menu and so on.</li> </ul>

## 2. The Operating Principle and Hardware Description

### F1 and the above Series Standard System Wiring Diagram( Sample)

### Standard Wiring Diagram 1 (Applicable to F1 and above)

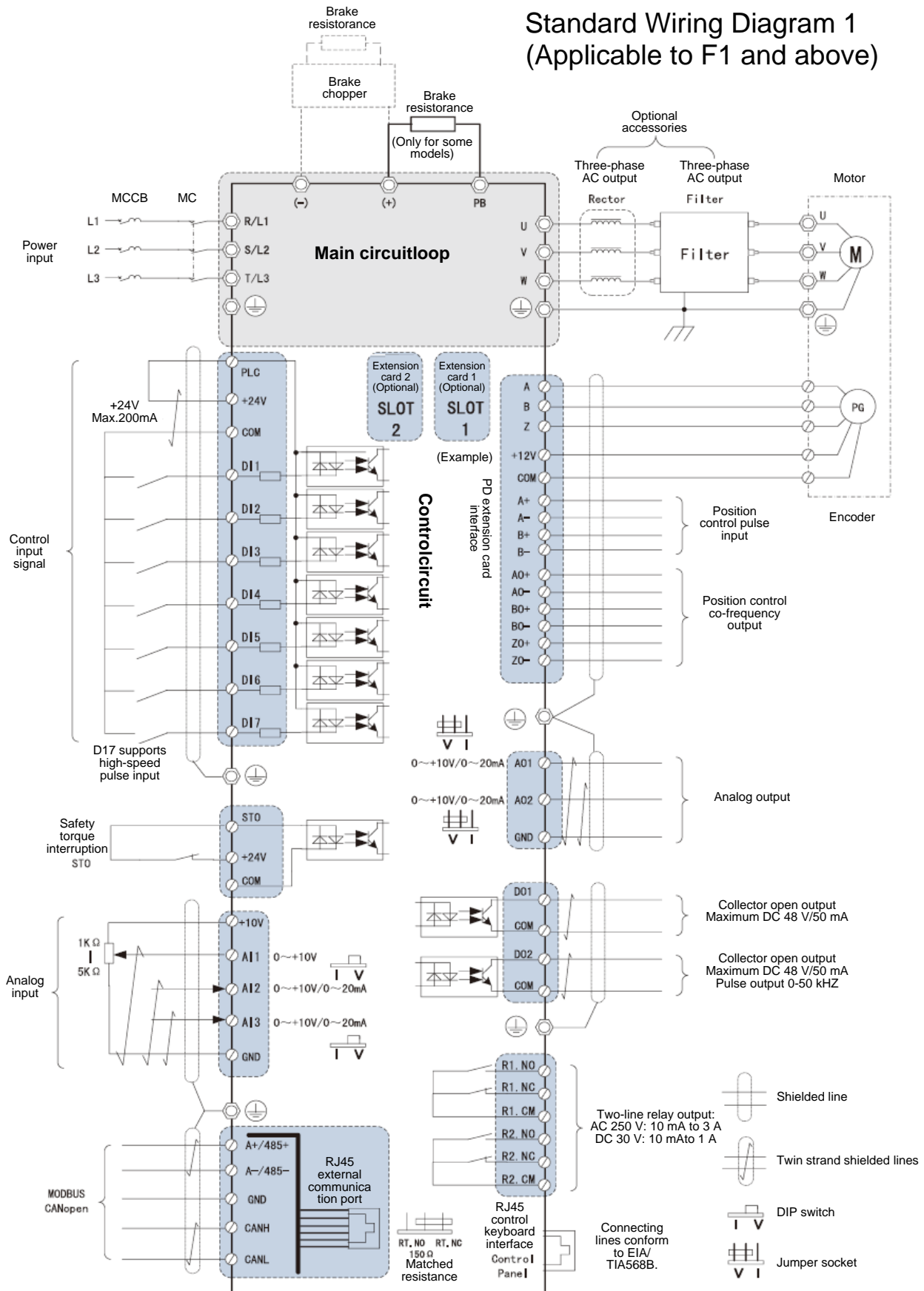

**F0 Series Standard System Wiring Diagram (sample)**

**Standard Wiring Diagram 2**  
 (Applicable to F0)

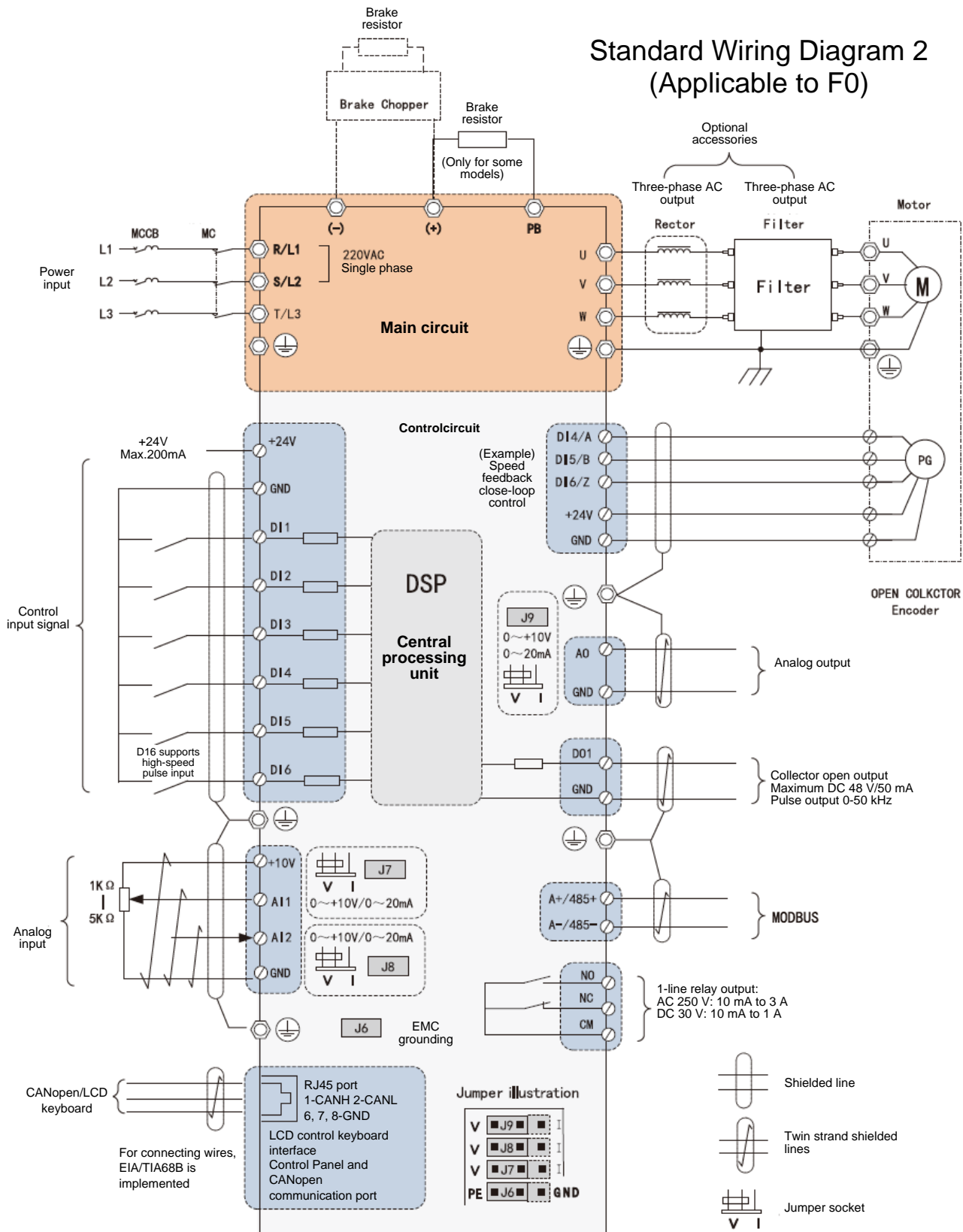

## 3. Cabinet and Mechanical Installation Design

Chapter Content	This chapter will guide how to plan the drive module to be installed in the user defined cabinet. Issues discussed are very necessary for the safe operation of the drive system.
-----------------	---



Note: The installation sample of this manual is only for providing installation design help for installation personnel. Please note that the installation design of the drive must be comply with the provisions of the relevant laws and regulations of the installation. If the drive is installed in violation of local laws/regulations, our company does not assume any responsibility.

### Cabinet Structure

Cabinet frame must be strong, capable of carrying the drive components, the control circuit and the weight of other equipments installed inside the cabinet. Cabinet must provide protection against touch drive module, and meet the requirements of dust and moisture (Please refer to the [Technical data](#) Chapter 1).

#### Equipment Layout

In order to facilitate the installation and maintenance, it is recommended to carry out the space layout. Adequate cooling air flow, mandatory intervals, cable and cable support structures are required for space.

If need to know about sample layout, please refer to the following [Cooling and Protection Grade](#)Section.

#### Grounding of Installation Structure

Ensure that all connections or shelves that in the drive system components are properly grounded, and the connection surface not coated with paint.



**Note:** Make sure all components are properly grounded through the fastening point on the base.

**Note:** It is recommended that the EMC filter (if any) and the drive module are installed on the same mounting panel.

## Cooling and Protection Grade

The cabinet must provide enough free space for the components to ensure for sufficient cooling. Please comply with the minimum clearance requirements of each components.

Air inlet and outlet must be equipped with the grille, which used for

- Direction of airflow direction
- Avoid of touch
- Avoid of splashing water droplets sputter into the cabinet

The amount of the cooling air required for the cabinet should be determined by reference to the corresponding values of the rated power and technical data and the calculation of the total installed capacity in the cabinet.

The cabinet system shall have the measures to prevent the circulation of hot air, to avoid the hot air circulating outside the cabinet by guiding the hot air leave the air inlet area. Following are possible solutions:

- Use the grille to guide the air flow of the air inlet and outlet area
- Air inlet and outlet are placed on different sides of the cabinet.
- The cold air inlet is located in the lower part of the front door, and an additional exhaust fan is installed at the top of the cabinet.

The cabinet can avoid the hot air circulation in the internal cabinet by using the leakproof wind shield.

If the cabinet has the risk of condensation water, then use the cabinet heater. Although the main function of the heater is to keep the air dry, it may also be used to heat it at low temperatures. Please follow the instructions provided by the manufacturer when placing the heater.

Among them the space around the drive can ensure the circulation of certain amount of the cooling air and the maintenance to the drive. The specific data are detailed in the table below.

If there are more than one drives need to be installed in up and down arrangement, the spacing should be equal to C+D (see below). And the outlet air flow of the lower device can not be opposite to the air inlet of the upper device. And shall ensure that the temperature of the cooling air must not exceed the maximum ambient temperature limit of the drive.

Minimum space requirements for the drive of cooling and installation

Drive volume size	Space minimum interval size(mm)			
	A	B	C	D
F0*(Two side non pass)	0	0	30	20
F0**( Two side band )	10	15	30	20
F1,F2	20	20	50	30
F3,F4,F5	10	20	100	50
F6,F7	15	30	150	80
F8,F9,	30	60	250	100

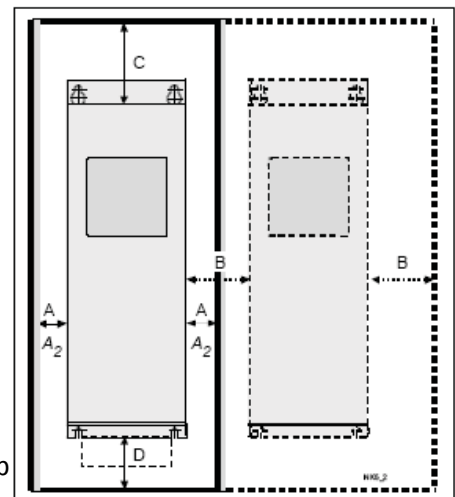

Table 3-1 installation space size map 3-1 installation space sketch map

- A** =Free space around the drive (see A2 and B)
- B** =The distance between the drives or between the drive and the wall of the cabinet
- C** =Free space on the drive
- D** =Free space below the drive

### 3. Cabinet and Mechanical Installation Design



## Configuration and Mechanical Installation Size

The drive can be vertical (for better cooling the drive, should be preferred) or horizontally mounted on the wall or the backboard of the control cabinet.

In order to ensure the adequate cooling of the drive, there should be enough space around it, as shown in Figure 3 -1, table 3-1, and note that the mounting plate should be relatively flat.

Drive the application of 4 screws (or bolts, depending on the size of the drive) fixed. Installation size refers to Figure 3-2 and table 3-2.

If you need to hang out the drive with size greater than F5 out of the packing box, you should use the jib crane, please inquire the factory or local vendors how to hang out the drive safely.

Wall type as the main application and installation form, the installation size see Figure 3-2

Flange mounting installation type, and F6 and the above drives adapt the vertical landing fixed hole installation, the size of its installation required can consult our representative to reconfirm.

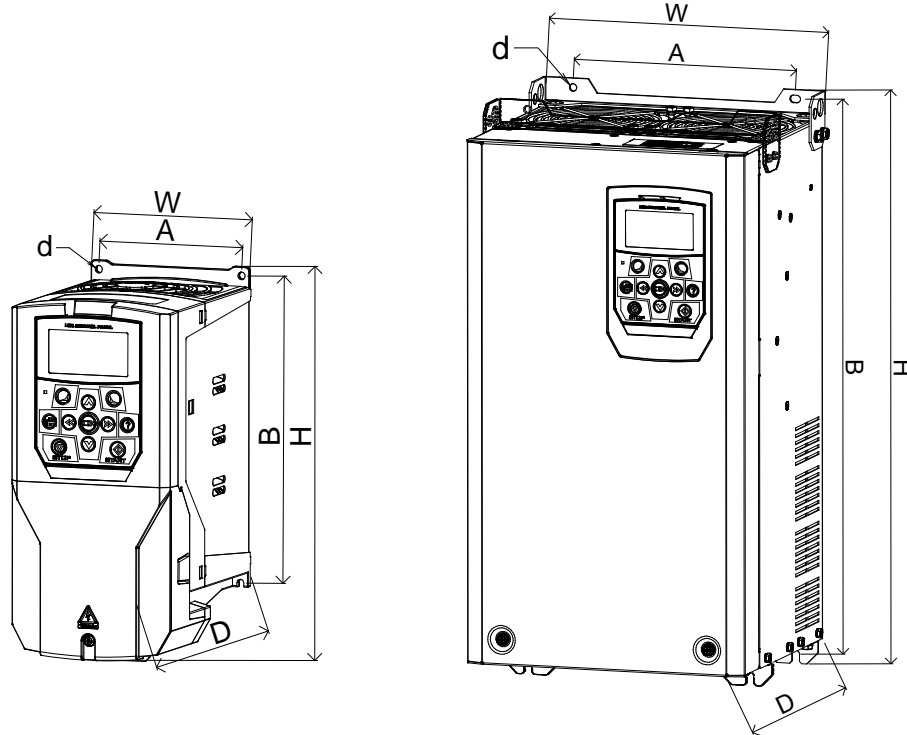

Figure 3-2. Configuration and wall mounted installation size diagram

Outline dimension	Installation Hole Width Spacing A (mm)	Installation Hole Height Spacing B (mm)	Installation Hole Sized (mm)	Appearance Width W (mm)	Appearance Height H (mm)	Appearance Thickness D (mm)	Net weight approximately (Kg)
F0	65	168	5.0	82	176	131	1.3
F1	110	222	5.5	122	276	172	2.9
F2	140	238	6.0	155	292	172	3.7
F3	150	368	7.0	180	420	216	10.7
F4	200	479	6.5	255	495	221	21
F5	250	650	12.0	355	670	260	61
F6	357/75**	761	11.0	390	790	278	90
F7	357/115**	973/977	11.0	390	1001	295	≈110*
F8	490/200**	1280	13.0	537	1305	340	≈190*
F9	490/240**	1420	13.0	537	1455	380	≈220*

\* Indicates the estimated drive net weight, more accurate value to be updated or please consult our company.

\* Please refer to the end of the book for the outline dimensions and mechanical installation dimensions, to learn more graphics and textures details.

\*\*Indicates the book type mounting hole spacing / blade type lateral mounting direction hole spacing. For the mechanical dements for the installation and the shapes of the industry dedicated derivative models not listed in the above table, please refer to the physical or contact our company's representatives.

### 3. Cabinet and Mechanical Installation Design

## Preparation work before the installation

### Delivery inspection and drive module identification

Check whether the delivered product is damaged or not. Before starting the installation and operation, please carefully check the type plate on the delivered drive module to confirm whether the product model of the delivered product is the same as that of the ordered product. The type plate is located on the top of the drive module or at the top of the left side. Typical examples are as follows (Other applications and models please consult our company):

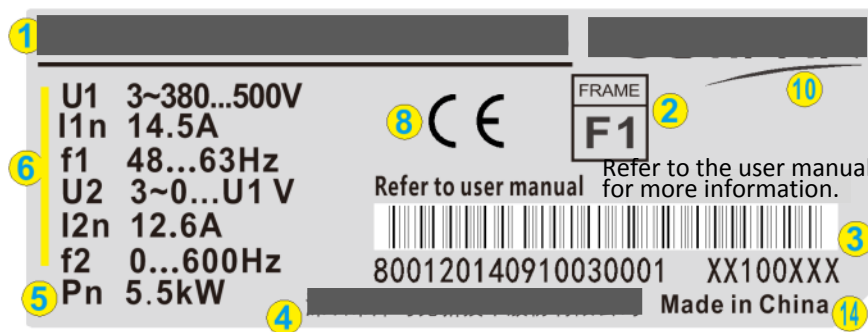
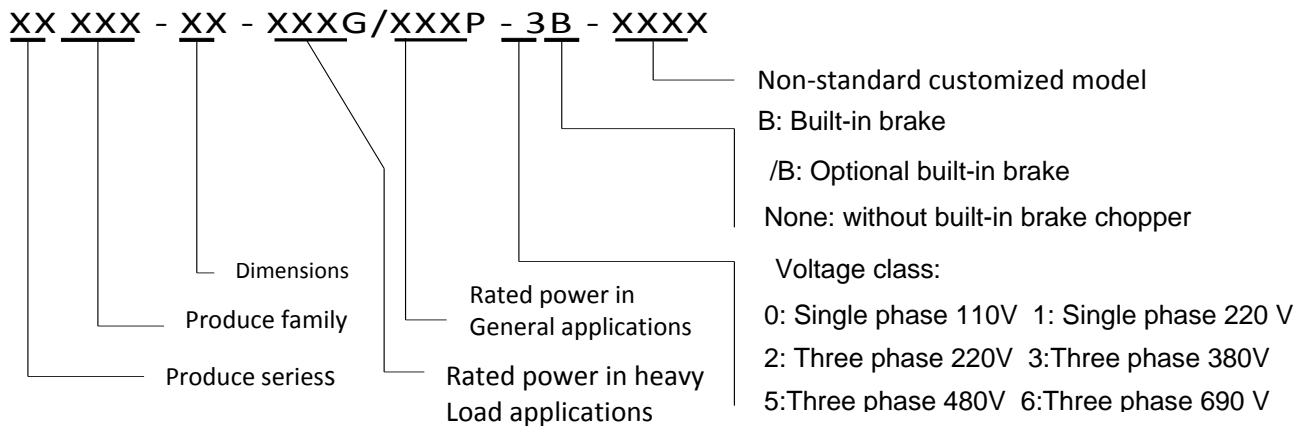

1=Model number, 2=Shapes and volumes, 3= Serial number, 4= Enterprise name, 5=Power, 6=Voltage/Electricity/Frequency, 8=Certification mark

### Installation location requirements

Information about the operating conditions that are allowed by the drive, Please refer to [technical data](#). Installation according to the upright direction. The walls of the installation are to be as flat as possible, using flame retardant materials, and there is enough strength to carry the weight of the drive. The floor below the drive should be flame retardant.

## Installation steps

### Direct wall mounting type installation

1. Mark the position of the four holes. The mounting points is shown in the diagram.
2. Fix the screws or bolts to the marked position.
3. Put the drive on the screws on the wall. **Pay attention to:** Only can pick up the drive by the base, otherwise there is a risk of shedding.
4. Fasten the screws.

### Floor mounting type (Only for the outline dimension is F6 and the above)

1. In accordance with the installation size of the base to burrow or lay buried studs in the target installation ground.
2. Place the drive on the mounting surface and lock it with anti - loose combination nuts.

## 3. Cabinet and Mechanical Installation Design

## ■4. Electrical installation design

### Contents of this chapter

This chapter introduces the principle to be observed on the selection of the motor, the cable, the protector, the cable wiring and the operation method of the drive. If the user does not comply with the recommendations, the drive may trip which is not in the scope of the warranty range of the fault.



**Pay attention to:** The installation and the design of the drive shall comply with the relevant laws and regulations of the installation. If the installation of the drive is in violation of the requirements of the local laws and regulations, we shall not assume any responsibility.

### Motor selection

According to the rating table of the chapter of **technical data** to select (the three phase AC induction type) electrical motor, the motor rating of each drive type is listed in the table.

Only one permanent magnet synchronous motor can be connected to the drive. It is recommended to install a safety switch between the permanent magnet motor and the drive output. In the process of maintenance of the drive, you can disconnect the permanent magnet synchronous motor from the drive by this switch.

### Power connection

Use a fixed connection among the AC power lines.



**Warning!** According to the requirement of IEC 61800-5-1, need to use the fixed installation as the leakage current of the device may exceed 3.5 mA

### Power circuit breaker

A manually operated input isolation device (isolation means) shall be installed between the AC power supply and the drive, which must be locked in the open position for easy installation and maintenance.

**Europe** If the driver used in the application must meet the “EU machinery safety instructions” required by the criteria of EN 60204-1 “Machinery and equipment safety”, and then the circuit breaker must be one of the following types:

- AC-23B (EN 60947-3) category load switch
- A circuit breaker with an auxiliary contactor. The auxiliary contactor disconnects the load circuit before the main contactor of the breaker is disconnected.

(EN 60947-3)

- Circuit breaker suitable for isolating as per the requirements of EN60947-2.

#### Other areas

Circuit breaker measures must meet the requirements of safety regulations.

## Thermal Overload and Short Circuit Protection

**Thermal overload protection:** If the cable is selected according to the rated current of the drive, then the drive can be self protect and protect the motor cable to prevent thermal overload. Additional thermal overload protection equipment is not required.



**Warning !** If the drive is connected to a plurality of motors, you must use a separate thermal overload switch or circuit breaker to protect the cable and the motor. These devices may need to use a fuse to cut short circuit current.

**Motor cable short circuit protection:** When the motor cable is selected according to the rated current of the drive, the drive can protect the motor cable and the motor when it is in short circuit. Other protective equipment is not required.

**Short circuit protection in power cable or drive:** Use a fuse or circuit breaker to protect the power supply cable. The recommended value of the fuse is given in the chapter of **technical data**. When the standard IEC gG or UL type T fuse is located on the distribution board, will be able to provide protection to the input cable under short-circuit conditions, reducing drive damage, avoid damage to adjacent equipment when short circuit occurs in the internal drive.

**Working time of fuse and circuit breaker: Check whether the fuse action time is less than 0.5 seconds.** The action time depends on the type, the impedance of the grid, the cross-sectional area of the cable, the material and the length of the fuse. The United States fuses must be "No Time Delay" type.

**Circuit breaker:** The protection characteristic of the circuit breaker depends on the power supply voltage and the circuit breaker type and structure. Meanwhile there are restrictions on short-circuit capacity of the power grid. In the condition of the known grid characteristics, our representative at your local can help you choose the type of circuit breaker.

**Motor thermal protection:** In accordance with the regulations, the motor must be protected to prevent thermal overload, and the current must be cut off when the motor is detected. The driver is equipped with thermal overload protection of motor, which can protect the motor and cut off the current when necessary. Depending on the parameter values of the drive, the function monitors the calculated values of the temperature (based on the thermal model of motor) or the actual temperature indication provided by the temperature sensor of the motor. The user can fine tune the thermal model by inputting additional motor and load data. PTC sensor can be directly connected to the drive. Please refer to the corresponding firmware manual for the parameter settings related to the thermal protection of the motor.

### Ground Fault Protection

The drive has an internal ground fault protection function, which can protect the equipment when the motor and the motor are connected to the ground fault. This is not a personal safety or fire protection function. Grounding fault protection function can be disabled by parameters, please refer to the corresponding firmware manual.

An optional EMC filter is a capacitor which is connected between the main circuit and the driver. These capacitors and longer motor cable increase the ground leakage current. Circuit breaker may make the wrong action.

### Emergency Stop Equipment

For safety reasons, an emergency stop device is required at each station and other stations requiring emergency stop.



**Be careful:** Press the stop key on the drive control keyboard will not produce a motor emergency stop, and the drive will not be isolated from the dangerous voltage.

### Safety Torque interrupt

The safety torque interrupt function will cut off the control voltage of the drive power semiconductor device; thereby preventing the voltage generated by inverter which motor rotation required. With this function, user can perform short - term operation of non - electric components (such as cleaning) and / or maintenance work without cutting off the power supply of the drive.

**Be careful:** The contact of the activation switch must be opened / closed within 200 ms. The maximum cable length between the drive and the active switch is 25 m (82 ft).



**Warning!** The safety torque interrupt function does not disconnect the voltage of the main circuit and the auxiliary circuit from the drive.

Therefore, only after the drive system is isolated from the main power supply can the maintenance of the electrical components of the drive or motor be performed.

**Be careful:** If the running drive is stopped by the safety torque interrupt function, the drive will cut off the power supply voltage of the motor and the motor will be free to stop.

## Power Cable Selection



**General principles :** The specification of the grid side and motor cable shall comply with the requirements of the local regulations:

- The cable must be able to carry the load current of the drive. Please refer to the chapter of the **technical data** to learn the current rating. Meanwhile, the size of the the general recommended power cable is given.

- The rated value of the cable must be up to the maximum allowable temperature for continuous use. 70 °C (U.S.A: 75 °C [167 °F]).

- The impedance of the PE conductor / cable (ground wire) must be able to meet the requirement of a possible contact voltage when a fault occurs (to ensure that the voltage of the fault point will not rise sharply when a ground fault occurs).

- 600 VAC cable is suitable for system below 500 VAC.

- Please refer to the chapter of **technical data** to learn the EMC requirements.

In order to meet the EMC marking requirements of CE and C-tick, a symmetric shielding motor cable must be adapted (see figure below). The input cable can be used for four core cables, but the use of shielded symmetric cable still recommended. When the protective wire made of the same metal phase, to play a role in protecting the conductor, the conductive shielding must be achieved the following requirements:

The cross-sectional area of a line(S)	Minimum sectional area of protective conductor(S <sub>p</sub> )
$S \leq 16 \text{ mm}^2$	S
$16 \text{ mm}^2 < S \leq 35 \text{ mm}^2$	16 mm <sup>2</sup>
$35 \text{ mm}^2 < S$	S/2

Compared with the four wire system, using the symmetric shield cables apart from the electromagnetic radiation and the current of the motor bearing can reduce the whole system. A motor cable and PE shielding wire (twisted shielding) should be as short as possible to reduce the electromagnetic radiation, as well as the external cable stray current and the capacitive current.

## Power Cable Type For Selection

The following describes the type of power cable drive available.

### Motor Cable

(Also recommended for power cable)

**Symmetric shielded cable:** Three phase conductors and a concentric or symmetrical PE conductor, and a shielding layer

**Be careful:** If the electrical conductivity of the motor cable shield can not meet the requirements, it is necessary to use a separate PE wire. Please refer to the [general principles](#) section above.

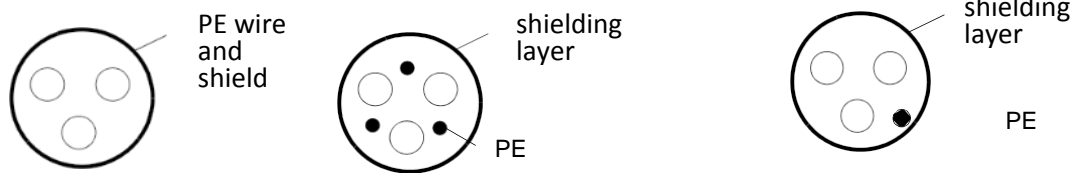

### Power Cable For Use

**Four conductor system:** Three phase conductors and a protective conductor.

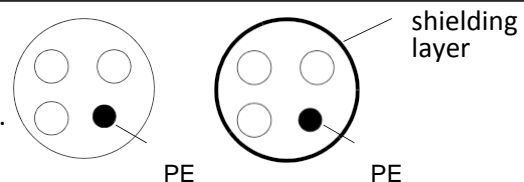

### Motor Cable Shield

In order to protect the conductor, when the shielding wire and the phase conductor adopt the same material, the cross-sectional area of the shield wire must be the same as that of the phase conductor.

In order to effectively suppress the RF interference emission and transmission, the performance of conductive shielding wire must be at least 1/10 of the phase conductors. For copper or aluminum shielding layer, this requirement is very easy to meet. The minimum requirements for the drive motor cable are shown below. Composed of coaxial copper braid, the tighter the shielding layer is, the electromagnetic interference through the launch of the current is smaller.

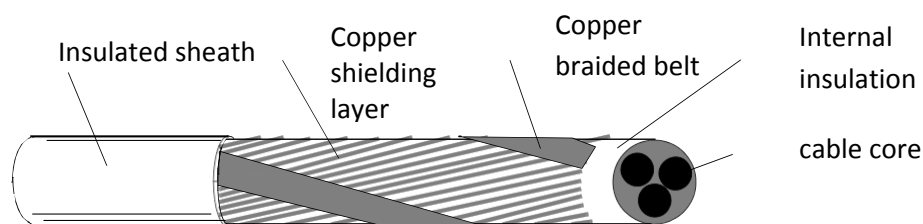

### Protect the output contact of the relay, suppress the interference caused by inductive load

When the inductive load (relays, contactors, motors) is disconnected, may cause voltage mutations. The relay output on the drive is protected by a voltage sensitive resistor (250 V) to eliminate the effect of the overvoltage peak. In addition, in order to minimize the perceptual load of the electromagnetic radiation generated in power, using electromagnetic attenuation circuit [Voltage sensitive resistor, RC filter (AC) Or diode (DC)] is recommended. If it does not suppress the electromagnetic interference, such interference may be controlled by controlling the cable compatibility or inductive transmission to other conductors, the function of the other parts of the system failure.

## 4. Electrical installation design

Install protective components as close to the inductive load as possible, not close to the relay output.

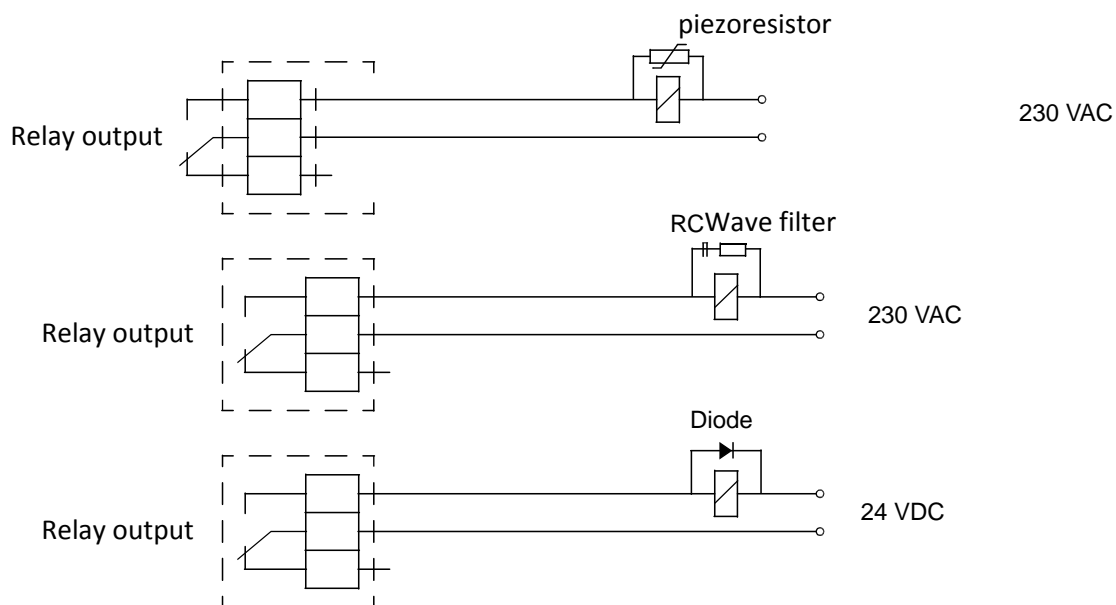

### Consideration of PELV requirements at sites above 2,000 m (6562 ft)

In the installation sites above 4000 meters (13123 ft), if the voltage used is more than 48 V, the relay output of the driver can not meet the requirements of protective extra low voltage (PELV). Installation site at 2000 m (6562 ft) to 4000 m (13123 ft), If one or two relay outputs are used with a voltage of more than 48 V and the rest of the relay output is less than 48 V, can not meet the PELV requirements.

## Control Cable Selection

**It is recommended that all control cables be shielded.** For analog signals, it is recommended to use a double shielded twisted pair. For the pulse encoder to walk the line, please follow the instructions provided by the manufacturer of the encoder. Each signal is paired with a pair of separate shielded pairs. Different analog signals do not share the route. For low voltage digital signals, it is best to use a double shielded cable, but also can use single layer shield (See Figure *b*).

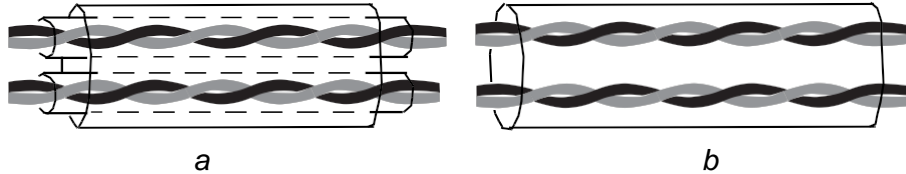

*a*  
Twisted pair shielded cable

*b*  
A single twisted pair shielded cable

Analog signals and digital signals are separated by different cables.

For signal relay control, If its voltage is not more than 48 V, then the relay cable and the digital input signal cable can be arranged in the same cable. The proposed relay control signal uses twisted pair. 24 VDC and 115 / 230 VAC signals are not arranged in the same cable.

### Relay cable

Cable with braided metal shield (Such as Germany Lapp Kabel the LFLEX) has passed the test, and has been recognized by the industry.

### Control keyboard cable

Control keyboard port using RJ45 interface, the extension of the line is a common standard for straight line (Plug in connector EIA/TIA568B standard). The cable length of the connection control keyboard and driver is not longer than 3m. Such as the use of more than five kinds of wires and has a good electromagnetic environment, extension of the line up to 15m.

### Communication cable

The drive comes with the communication RJ45 terminal definition as below table and figure. Other forms of communication port, please refer to the corresponding expansion card of each specification

Line number	Channel name	Target communication
1	CANH	CANopen
2	CANL	
3	NC	
4	GND	CANopen
5	GND	
6	GND	MODBUS
7	A-	
8	A+	



RJ45 plug contact



**Be careful:** Do not connect the two terminals in shield layer of the cable which is from motor temperature sensor to drive directly to the ground. If one terminal can not install 3.3nF capacitor between the shielding layer and the ground, only other one terminal grounded.

## Cabling

The cable of the motor must be far away from the other cables. Several motor cables can be arranged in side by side. It is proposed that the motor cable, the input power cable and the control cable are distributed in different wire slot. In order to avoid the electromagnetic interference caused by the fast change of the output voltage of the driver, the long distance from the motor cable and other cables should be avoided by walking the line side by side.

When the control cable must pass through the power cable, ensure that the included angle between the two cables as far as possible to maintain 90 degrees. Do not put other cables across the drive.

Keep good connection between cable slots and good grounding. Aluminum wire slot can be used to improve the potential bonding.

## 4. Electrical installation design

Tel: ۰۲۱- ۴ ۸ ۰ ۰ ۰ ۰ ۴ ۹

Fax: ۰۲۱ - ۴ ۴ ۹ ۹ ۴ ۶ ۴ ۲

تهران، کیلومتر ۲۱ بزرگراه لشگری (جاده مخصوص کرج)

روبروی پالایشگاه نفت پارس، پلاک ۱۲



Cable wiring diagram see figure below

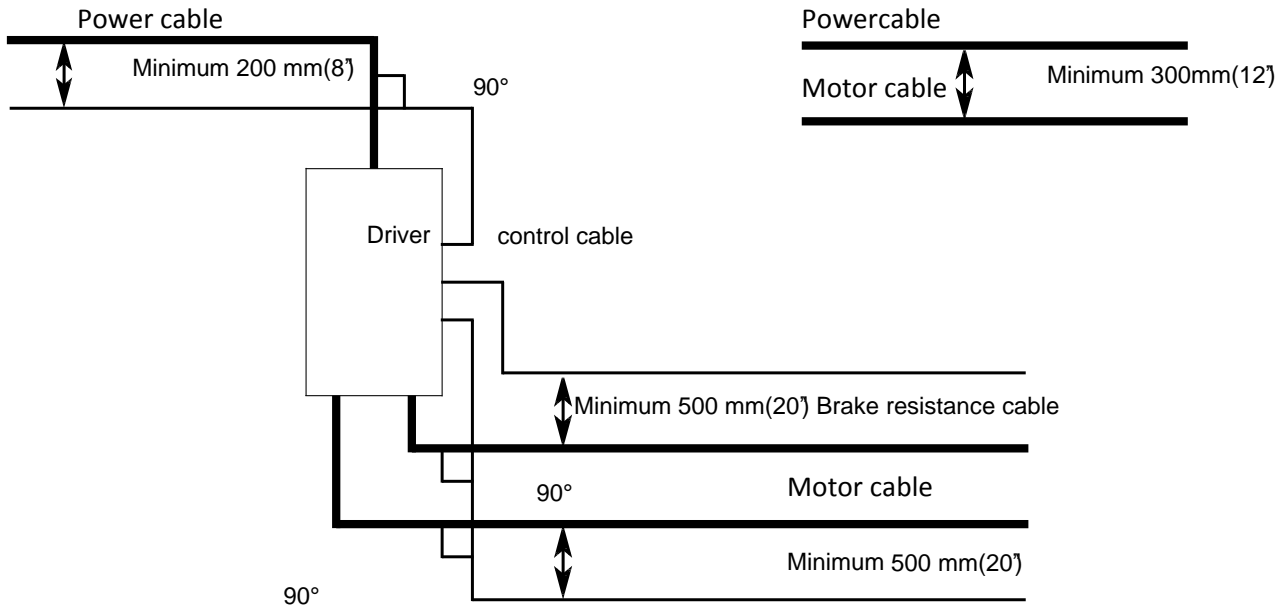

**Control cable trough**

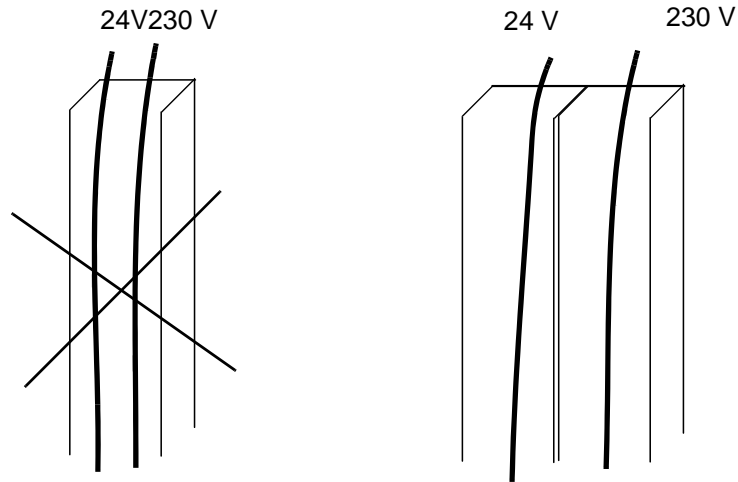

**On the left:**

If 24 V for 230 V is not insulated or not through the insulating sleeve on the 230 V insulation, the 24 V cable and the 230 V cable are not allowed to be discharged in a conduit.

**On the right:**

Different slot will be 24 V and 230 V control cable arranged in the cabinet.

## ■ 5. Electrical Installation

Contents of

this chapter This chapter describes the drive of the electrical installation process.



**Warning!** Only a qualified electrical engineer can carry out the work described in this chapter. Please observe the first page of this manual. Ignore these safety instructions may cause personal injury or equipment damage.

In the installation process must ensure that the drive power supply (input power) has been disconnected. If the drive has been powered. After the power off, please wait for at least 10 minutes.

**The series drive's case is structure designed with high protection ability. In general terms, the basic procedure for the connection is:**

1. Loose the safety screw in front of cover (door), and remove the cover (door).
2. With a sharp cut into the wire on the board (the O ring shaped rubber ring) or partial resection of the spire to the appropriate aperture (applied to the rubber ring), F0-F2 models will be skinned (length 8-10mm) of the power cable, For F3 and above models will have good power cable terminal after pressure through the hole into the rubber ring on the board after the insertion of a power connecting terminal, According to the torque in **Table 5-1** fastening screws can be. And the ground wire is connected to the machine shell.
3. Re install the cover plate in accordance with the above steps.

 www.famcocorp.com

 E-mail: info@famcocorp.com

 @famco\_group

 Tel: ۰۲۱-۴۸۰۰۰۰۴۹

 Fax : ۰۲۱ - ۴۴۹۹۴۶۴۲

تهران، کیلومتر ۲۱ بزرگراه لشگری (جاده مخصوص کرج)

روبروی پالایشگاه نفت پارس، پلاک ۱۲

#### Driver

Withstand voltage or insulation resistance testing of the drive and its components is not required (For example high voltage insulation test or test insulation resistance with a gauge). Before leaving the factory, each driver has been tested for the insulation of the casing by the main circuit. And driver internal finite voltage circuit, Can automatically cut off the test voltage. Therefore, it is not necessary to carry out any Withstand voltage or insulation resistance test for the driver and its components. (For example high voltage insulation test or test insulation resistance with a gauge).

#### Power cable

Before connecting the drive to the power cable, check the insulation of the power (input) cable in accordance with local rules.

The steps of the motor and motor cable insulation inspection are as follows:

1. Ensure that the motor cable is connected to the motor, And then the motor cable from the driver's output terminal U、V and W.

2. Measure the insulation resistance between each phase conductor and the ground conductor with a 500 DC V. The insulation resistance of the typical motor must be more than 10 MB (25 °C or 77 °F When the given value). For other specific motor insulation resistance, Please refer to the manufacturer's instructions. Be careful: If the motor is damp, the insulation resistance will decrease. If you suspect that there is moisture, the motor should be dried and re measured.

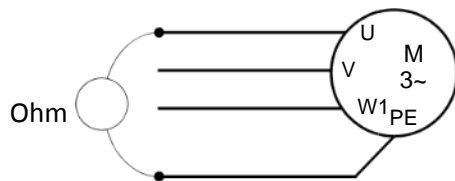

#### Braking resistance device

Check the brake resistor assembly (if any) of the insulation in the following manner:

1. Check that the resistance cable has been connected to the resistance, and disconnect from the driver's output terminal + and PB.
2. At the drive side, the resistance cable is connected to the + and PB wire. Using measured voltage 1 kV DC, measurement of the connection between the wire and the PE wire insulation. The value of insulation resistance must be higher than 1 Mohm.

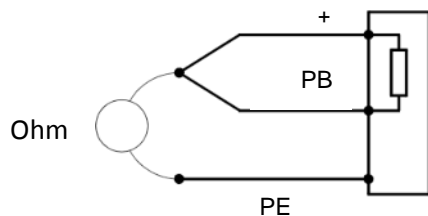

## Connection procedure

According to the wiring diagram and the next table is given the fastening torque of the connection operation:

1. According to the following example of the outline size, open the wiring cover.
2. In IT (floating ground) system and angle ground TN system, Remove the following screw to disconnect the internal piezoresistor and EMC filter:
  - VAR (shape F3, located at the power terminal left)
  - EMC (shape F1-F3, located near the power supply terminal. F4-F9 is located inside structure, and can see the mark after removing the front cover.



**Warning !** If the drive is installed into the IT system (a non grounded power system or a power supply system with a high resistance ground (more than 30 Ohm), when piezoresistor / filter connect to ground, this may cause damage to the drive. If the drive is connected to the angle ground of TN system, when not disconnected piezoresistor/ filter, the drive will be damaged.

3. Cut or cut the line terminal protection ring, some models need to sort the protection network.
4. Peel the cable, removing the cable clamping position shielding layer.
5. Lay the end of the cable shield wire to the braided wire. The end of the line peel cable.
6. Connect the power cable line to drive R, S and T or L1 and L2 terminals. Connect the cable of motor to U, V and W terminals. Connect the resistance cable (if any) to the + and PB terminals.
7. Clean the exposed cable shielding layer and connect to wire plate.
8. The cable shield layer is fixed to the ground terminal.

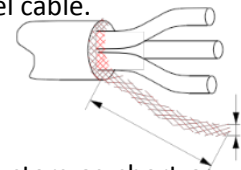

- Be careful:** To peel the shielding layer and the length of strip phase conductors as short as possible.
9. Please cover the exposed and braided wire with insulation tape.
  10. Fix the external cable of drive by tool.
  11. Connect the power cable shield or the other end of the PE cable to the power distribution board. If the input reactor or EMC filter is installed, make sure that the PE wire is connected from the distribution board to the drive.

### At the motor end, the motor cable is grounded

In order to minimize the RF interference, please put the cable shield in the 360 degree grounding at the hole of motor terminal box. Or through the twisted shielding layer to the grounding. Making the flattening of the shield width as 1/5 of its length.

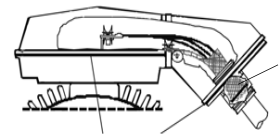

Table 5-1 terminal form and tightening torque

Dimension	terminal screw Size	tightening torque [Nm]	Terminal structure	Terminal symbol identification and description	Connection capacity
Control and relay terminals	M3	0.8-1.2	European square hole type compression joint terminal*	Refer to the wiring diagram	30-14AWG
F0	M3	0.8-1.2	European square hole type compression joint terminal*	Refer to the wiring diagram	30-10AWG
F1, F2	M4	1.5—1.8	European square hole type compression joint terminal*	PE, R, S, T, PB, +, -, U, V, W, PE*	20-6AWG
F3	M5	3.0—3.5	Fence pressing type terminal*	PE, R, S, T, PB, +, -, U, V, W, PE	22-6AWG
F4	M6	4.0-5.0	Fence pressing type terminal*	PE, R, S, T, PB, +, -, U, V, W, PE	10-22mm <sup>2</sup>
F5	M10	9.0-10.0	Fence pressing type terminal*	PE, R, S, T, PB, +, -, U, V, W, PE	25-75mm <sup>2</sup>
F6, F7	M10	17.0-22.0*	Fence piece type single terminal*	R, S, T, +, -, U, V, W, PE	36-90mm <sup>2</sup>
F8 <sup>1)</sup>	M12	35.0-55.0*	With M12 hole copper	R, S, T, +, -, U, V, W, PE	2*M12 Copper

F9 <sup>1)</sup>	M12	35.0-55.0*	With M12 hole copper	R、S、T、+、-、U、V、W、PE	3*M12Copper
F8 <sup>2)</sup>	M12	35.0-55.0*	With M12 hole	R(R1/R2)、S(S1/S2)、T(T1/T2)、	2*M12Copper
F9 <sup>2)</sup>	M12	35.0-55.0*	With M12 hole copper	R(R1/R2)、S(S1/S2)、T(T1/T2)、+、-、U、V、W、PE	3*M12Copper

Note: 1. The main power on the European type hole shaped crimp terminals can be peeled bare about 8-10 mm directly into the lock, the fence type terminal needs to press the connecting pin to lock tightly. 2. Some models have no built-in brake chopper function without PB terminals.

<sup>1)</sup>=380V~Enter a series of models when the terminal name, <sup>2)</sup>=660/690V Terminal name of series models, Where R/S/T is the 6 pulse rectifier input connection, R1/S1/T1, R2/S2/T2 for the 12 pulse rectifier input when the packet access to the previous stage of the two windings of the transformer 1、2.

## Schematic and installation instructions for each type of structure

Picture 5-1 F1-F3 series models to remove the terminal cover after the wiring port diagram

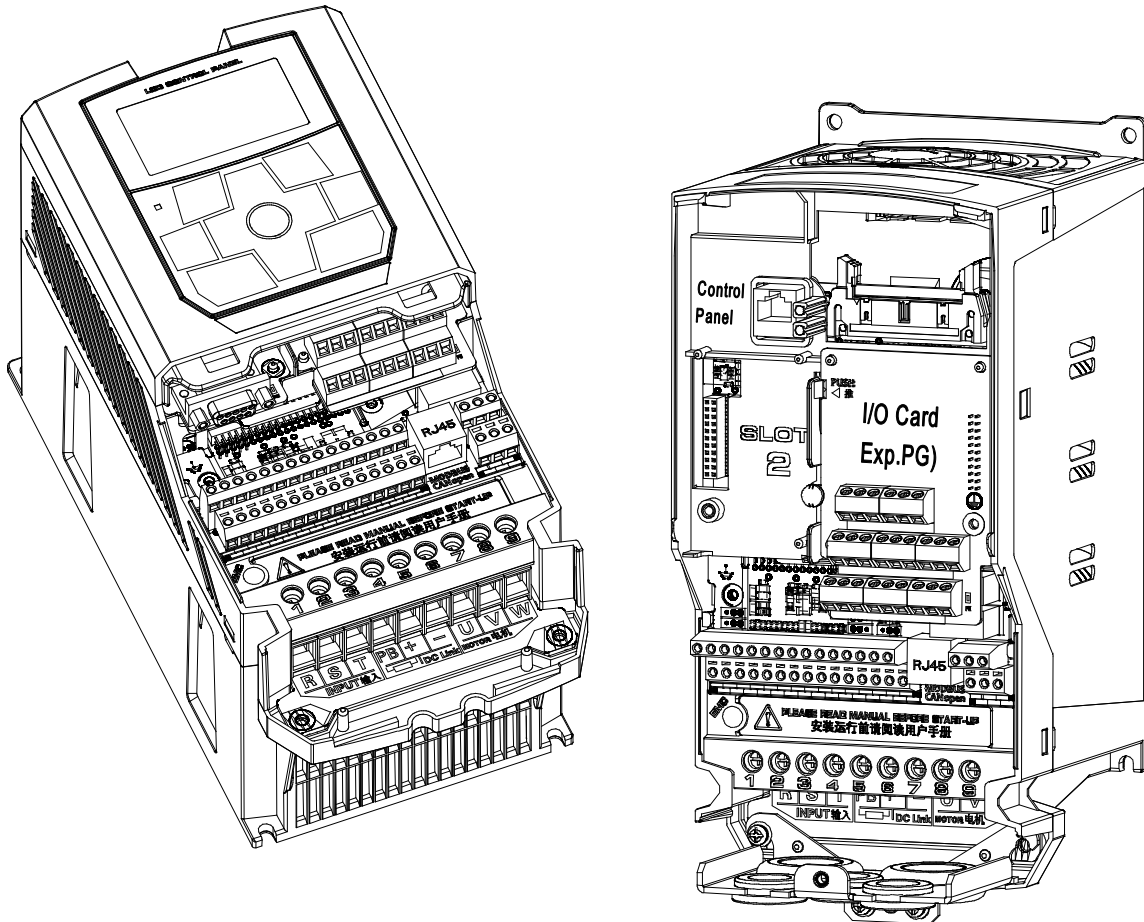

The casing of this series is a structure design with high protection ability. In general terms, the basic procedure of wiring is as below:

- 1) . Screw loose connection terminals cover (door) board, and remove the cover (door)
- 2) .With a sharp cut the inline ring on the board (for O shaped rubber ring) or partial resection of the spire to the appropriate aperture (applied to the rubber ring). F1-F2 models will be skinned (length 8-10mm) of the power cable. The pressed power cable terminal of F3 models insert through the hole into the rubber ring on the board and connect to power terminal, according to the torque in Table 5-1 fastening screws. And the ground wire is connected to the machine shell.
- 3) .Control cable in the reference line connecting terminal (or the appropriate pressed terminal) connect to drive
- 4) .Installation of expansion cards:  
With the hand from the top to pull off the control keyboard, loosening the screw at the bottom and remove the top cover, insert the expansion card into the corresponding card slot above the control panel. Connect the striped (or pressed) cable to drive's terminals.
- 5) .The cooling fan is positioned on the top of the drive ventilation. When changing, the protective cover of the fan is used as a tool (such as a word screwdriver). Take out of Fan and take off the power cable, Please note that when installed fan outlet should be outward (general fan body with an air of arrow).
- 6) .According to the opposite steps to install back the casing (cover), To ensure that the machine has a design protection.

### 5. Electrical installation

Tel: ۰۲۱-۴۸۰۰۰۰۴۹

Fax: ۰۲۱-۴۴۹۹۴۶۴۲

تهران، کیلومتر ۲۱ بزرگراه لشگری (جاده مخصوص کرج)

روبروی پالایشگاه نفت پارس، پلاک ۱۲

DC-Linkmesne UDC+ and UDC-Terminal is suitable for the common DC configuration of all series drives,Can be used in a drive to generate renewable energy supply to other drives in the motor mode.

According to the different power requirements,One or more drives can be connected to an AC power supply.

If only one or a few drivers are connected to the power supply to evaluate the power of its soft start module and the rectifier module is capable of supporting a total of DC bus network all the drive of the entire DC busCapacitor charging and output power rectifier,Otherwise, it will cause damage,Standard design for the same input voltage level of theF0-F3Standard design for the same input voltage level of the.For more information please consult a professional or call our representative.

If there are two or more drives connected to the AC power supply,Input reactor must be installed for each AC connection,In order to ensure the current distribution of the bridge between the bridge.For more information please consult a professional or call our representative.

**The following figure shows two example configuration.**

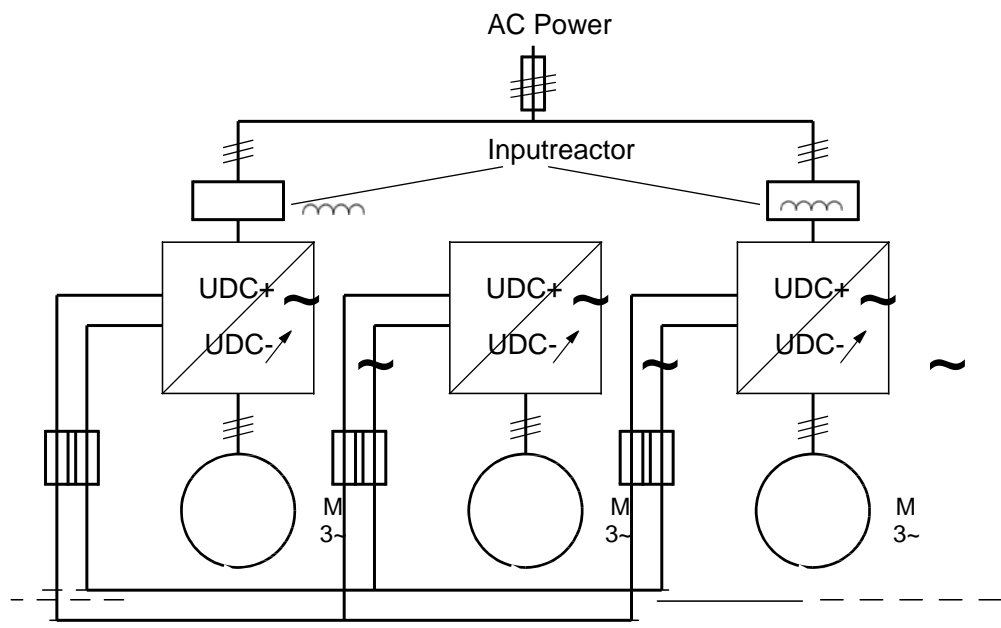
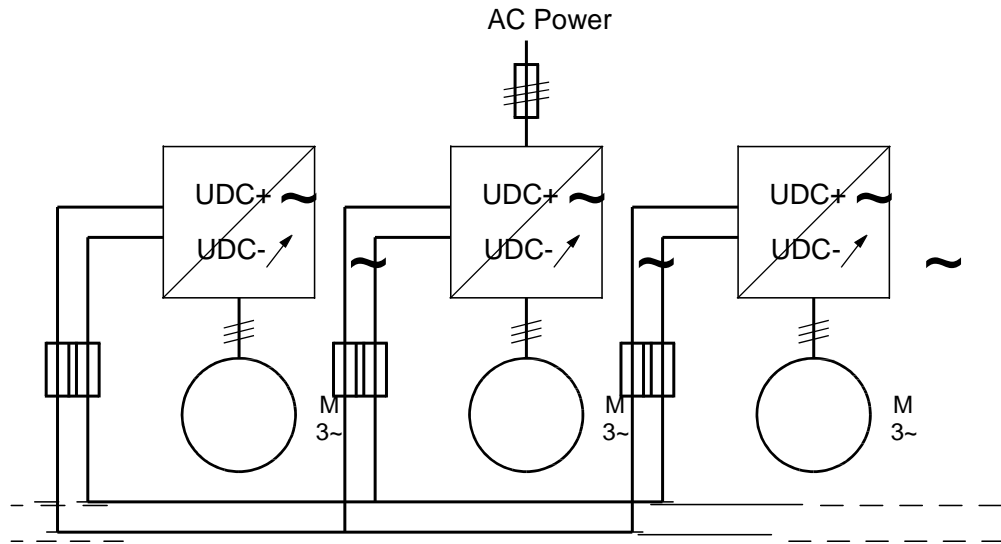

#### 5. Electrical installation

Tel: ۰۲۱- ۴ ۸ ۰ ۰ ۰ ۰ ۴ ۹

Fax: ۰۲۱ - ۴ ۴ ۹ ۹ ۴ ۶ ۴ ۲

تهران، کیلومتر ۲۱ بزرگراه لشگری (جاده مخصوص کرج)

روبروی پالایشگاه نفت پارس، پلاک ۱۲

## ■ 6. Installation Check list

### Check list



Carefully check the mechanical and electrical installation of the drive before starting the drive. Requires more than two engineering and technical personnel in accordance with the table below to check installation. Start working on the device before, Please read the manual of the first page of the safety instructions carefully.

### Scope of examination

#### Mechanical installation check list

- Ambient conditions must conform to the requirements. ( Please refer to mechanical installation, technical data: Rated value, environment condition .)
- Equipment properly fixed on the rack. (Please refer to the cabinet design and installation of machinery installation.)
- Cooling air flow is smooth, Cabinet put change draught fan air quantity whether or not enough.
- Motor and actuator installation is completed. (Please refer to the electrical installation design, technical data: Motor connection.)
- On dust, drops splash water, damp air, corrosive gases whether there is sufficient assessment and take corresponding measures.

#### Electrical installation check list

Please refer to the electrical installation design and electrical installation chapters' content and complete the steps. Then enter the following key process to confirm the inspection.

- If the drive is connected to the IT (floating) power grid, VAR (Dimension F3) and EMC (else Dimension) To loosen the screw.
- If the storage period is more than one year, The reforming capacitor is required. (Please refer to our local representative for more information).
- Drive properly grounded.
- Power supply (input power) voltage and the match rated input voltage of the drive.
- Power supply (input power) connected to R/S/T or L1/L2/L3 (For DC power supply UDC+/UDC-) upper, Terminals are tightened to the specified torque.
- Installed a suitable power supply (input power) fuses and circuit breakers.
- Motor is connected to the U/V/W, Terminals are tightened to the specified torque.
- Brake resistance (if any) connected to +/PB, Terminals are tightened to the specified torque.
- Motor cable (As well as the braking resistance cable, If there) Separate from other cables.
- There is no power factor compensation capacitor in the motor cable.
- External control of the control unit is connected.
- There is no tools left in the drive, Foreign bodies and borehole produce conductive dust.
- Power supply (input power) voltage can not through the bypass connection applied to the input terminals of the drive.
- Motor junction boxes and other covers are installed in place.



## 7. Maintenance

### Summary of daily maintenance

This chapter introduces the description of relevant preventive maintenance. Due to changes in drive usage environment, as temperature, humidity, smoke, dust, etc factors and drives' aging of the internal components of the factors etc may cause the drive to produce various kinds of faults. Therefore, in the storage, the usage of process must be carried out daily check and regular maintenance.

- Drive through the transport, before the use, should check whether the element in good condition, If screw fastening.
- Drive in the normal use of the period should be regularly cleaned up dust, And check whether the screw is loose.
- If drive is not used in long-term, proposed electricity charging once in the half year. Charging half hour is appropriate in order to prevent the failure of electronic devices.
- Drive should be avoided in wet and metal dust environment to use. Must be placed in electrical cabinets with protective measures or protecting room in the field.

### In normal operation of the drive, please confirm the following matters:

- Whether the motor has abnormal sound and vibration.
- Whether drives and motors are fever abnormality.
- Whether ambient temperature is too high.
- Whether the output current value is normal.
- Whether drive's cooling fan is functioning properly.



**Warning!** Before any maintenance work is carried out on the drive. Please read the safety instructions on the first page of this manual. Ignore these safety instructions may cause personal injury or equipment damage.

### Maintenance cycle

The following table shows the routine maintenance cycle recommended by our company. For more understand detailed information, please contact the local service representative office.

Maintenance cycle	Maintenance	Explai006E
Each year (storage)	DC capacitor reforming	see also <a href="#">Capacitor charging</a>
Each 6 to 12 months, depending on the amount of dust in the environment	Sink temperature inspection and cleaning	see also <a href="#">sink</a> .
Each year	Power connection fastening degree check	
	Cooling fan visual inspection	see also <a href="#">cooling fan</a> .
Each 3 years, if the ambient temperature is higher than 40 °C (104 °F). Otherwise Each 6 years.	Replace cooling fan	see also <a href="#">cooling fan</a> .
Each 3 years, if the ambient temperature is higher than 40 °C (104 °F). Or the drive is suffered to periodic heavy load or continuous rated load. Otherwise each 9 years.	DC capacitor replacement	Contact our local service representative.

## Sink maintenance and cleaning

The fins of the sink may accumulate the dust in the air. If the sink is not clean, drive will occur overheat warning and failure. In normal environment, the sink should carry out inspection once a year. In dusty environment inspection is more frequent.

Clean the radiator in the following manner (When needed ):

### F0-F5 models

1. Remove the cooling fan.
2. With a clean compressed air to blow (arid) from bottom to top, at the same time the vacuum cleaner is used to collect the dust at the air outlet.

Be careful: If the dust may enter the adjacent equipment, please clean it in the other room. The F4, F5 models have the cleaning hole designed which cleaning can be used fine drill insert. (See schematic left 2 figure)

3. Re install the cooling fan.

**F6 and above models the special design back with a clear window cover structure. Users can remove the back or side cleaning window cover, Clean the sink directly with the cleaning equipment. (Schematic diagram to see right one , 2 figure)**

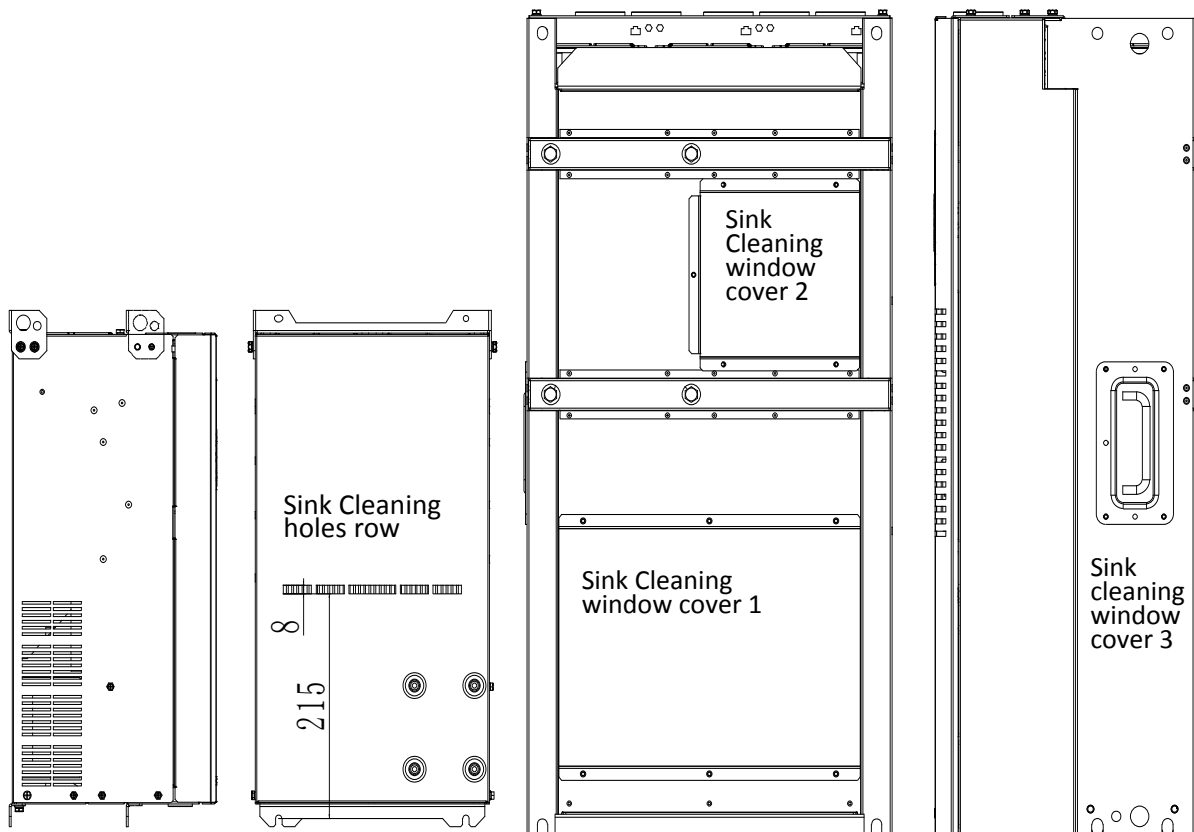

## 6. Maintenance

Tel: ۰۲۱- ۴ ۸ ۰ ۰ ۰ ۰ ۴ ۹

Fax : ۰۲۱ - ۴ ۴ ۹ ۹ ۴ ۶ ۴ ۲

تهران ، کیلومتر ۲۱ بزرگراه لشگری (جاده مخصوص کرج)

روبروی پالایشگاه نفت پارس ، پلاک ۱۲

### Cooling Fan

Fan's actual life depending on the use of drive as well as the ambient temperature. From the noise of fan bearings and the gradual rise of the heat sink temperature (Although the sink has been cleaned) upper, it can be predicted Fan failure. If driver used in key positions, user have to replace the fan when the fan is just beginning to make an abnormal noise.

#### How to remove the fan:

OnF0-F3: With a small – screwdriver, open the fan cover and take out of the fan

OnF4-F9: Using a screwdriver to remove the fixed air frame from the top of the drive and take out the fan or directly from the bottom of drive taking out the fan.



**Be careful!** The airflow direction is from the bottom up. When installing the fan, the air flow direction is upward. General fan has its steering and wind direction indicator arrow on the body. At the same time pay attention to arrange fan power cord, Avoid fan extrusion and blowing straight shaking the line

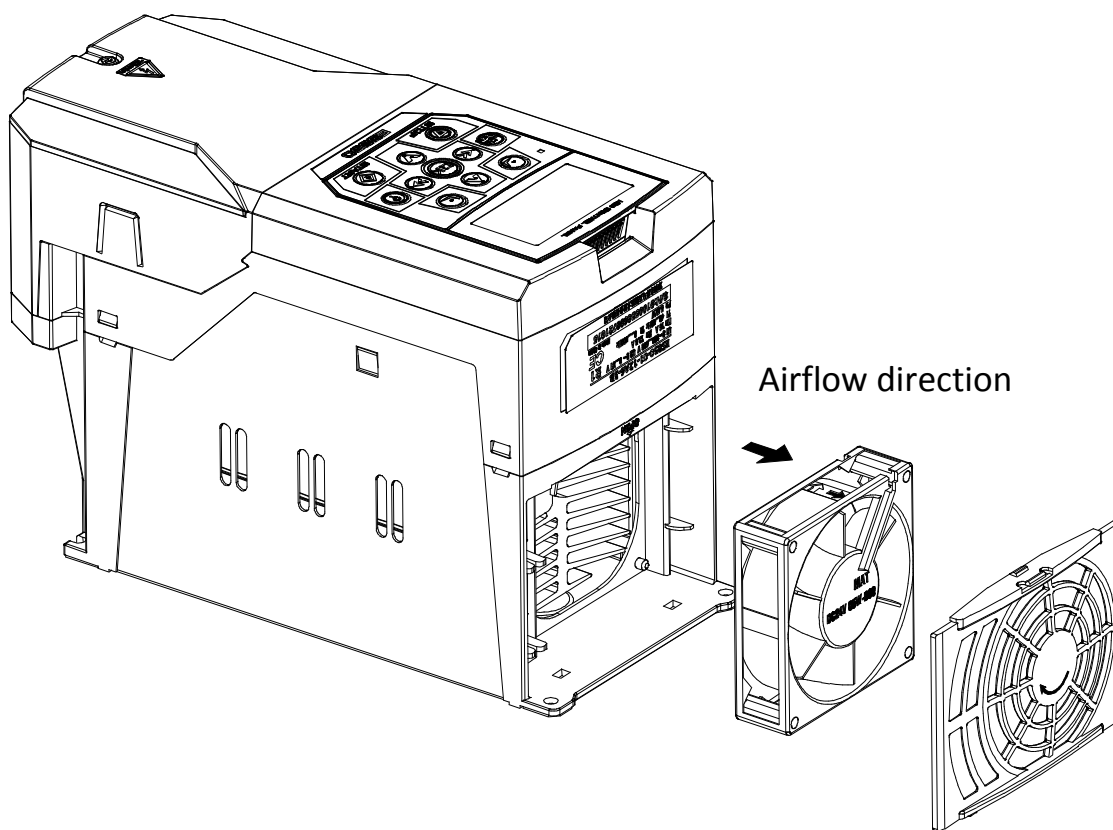

## Capacitor Charging

After a long storage time, capacitors need to be charged, in order to avoid damage of capacitance and limit the possibility of the high current leakage of the capacitor. The best way to achieve this goal is to use a DC power that can regulate the current limit.

- 1) According to the size of the drive, in 300...800mA range set current limit.
- 2) Then the DC power supply is connected to the terminals of DC-Link +/- terminals, Or directly connected to a capacitance. In a series of model drive without the DC-Link of +/- terminal, user can connect to the 2 input phases (R/L1 and S/L2) DC power supply.
- 3) And then set the DC voltage to the rated voltage of the drive ( $1.35 \cdot U_n$  AC) Charging for at least 1 hour. If the DC voltage is not available, drive has been stored for more than 12 months without power supply, please consult us before power on.

## Other maintenance operations

### Transfer user parameter settings to the new drive module (The selected models if there is this function)

When replacing the drive module, the parameters copy function of the control keyboard can be used to transfer the user parameters from the fault driver module.

By using pluggable type control terminal board can not dismantle the original control wiring of faulty drive and fast transfer under the condition of the terminal connectivity.

## 8. Technical Data

**Chapter Content:** Introduces technical parameters, rating, Dimension, technical requirements, complying to CE and other tags related description.

Rated Value		General Load Application		Heavy Load Application		Noise Level	Heat Radiation	Air Volume	Model Code	Dimension
IN A	I <sub>max</sub> A	IL <sub>d</sub> A	PL <sub>d</sub> KW	I <sub>Hd</sub> A	PH <sub>d</sub> KW	dBA	W	m <sup>3</sup> /h		
4.8	6	4.5	<b>0.75</b>	2.5	<b>0.37</b>	40	40	25	XXXXX-F0-0K4G/0K7P-1B	<b>F0</b>
7.5	10	7	<b>1.5</b>	4.5	<b>0.75</b>	40	65	25	XXXXX-F0-0K7G/1K5P-1B	
9	11.5	8.5	<b>2.2</b>	7	<b>1.5</b>	40	80	25	XXXXX-F0-1K5G/2K2P-1B	
10	12	-	-	9	<b>2.2</b>	40	92	25	XXXXX-F0-2K2G-1B	
3	6	4.5	<b>0.75</b>	2.5	<b>0.37</b>	45	40	53	XXXXX-01-0K4G/0K7P-1B	<b>F1</b>
5	10	7	<b>1.5</b>	4.5	<b>0.75</b>	45	94	53	XXXXX-01-0K7G/1K5P-1B	
8	15	10	<b>2.2</b>	7	<b>1.5</b>	45	172	53	XXXXX-01-1K5G/2K2P-1B	
11	20	-	-	10	<b>2.2</b>	45	232	53	XXXXX-01-2K2G-1B	

### Rated Value/Cooling fan flow rate/ Noise level

**Rated voltage 220V series**(table above)Note: This series of models in the table of theXXXXX representative product series, Specific to the real products.

**Rated voltage 380/400V series** (following table)

Rated Value		General Load Application		Heavy Load Application		Noise Level	Heat Radiation	Air Volume	Model Code	Dimension
IN A	I <sub>max</sub> A	IL <sub>d</sub> A	PL <sub>d</sub> KW	I <sub>Hd</sub> A	PH <sub>d</sub> KW	dBA	W	m <sup>3</sup> /h		
5.2	6	5	<b>1.5</b>	2.5	<b>0.75</b>	40	40	25	XXXXX-F0-0K7G/1K5P-3B	<b>F0</b>
6.3	7.5	6	<b>2.2</b>	4	<b>1.5</b>	40	76	25	XXXXX-F0-1K5G/2K2P-3B	
9.5	11	9	<b>4</b>	5	<b>2.2</b>	40	97	25	XXXXX-F0-2K2G/4K0P-3B	
10	12	-	-	8	<b>4</b>	40	125	25	XXXXX-F0-4K0G-3B	
5.2	7	5	<b>1.5</b>	2.5	<b>0.75</b>	45	40	53	XXXXX-01-0K7G/1K5P-3B	<b>F1</b>
6.3	9	6	<b>2.2</b>	4.2	<b>1.5</b>	45	76	53	XXXXX-01-1K5G/2K2P-3B	
10.5	15	9.8	<b>4</b>	5.6	<b>2.2</b>	45	97	53	XXXXX-01-2K2G/4K0P-3B	
14	20	13.5	<b>5.5</b>	10.5	<b>4</b>	45	172	53	XXXXX-01-4K0G/5K5P-3B	
18.2	25	17.5	<b>7.5</b>	14.5	<b>5.5</b>	45	210	53	XXXXX-01-5K5G/7K5P-3B	<b>F2</b>
26	36	25	<b>11</b>	17.6	<b>7.5</b>	45	325	55	XXXXX-02-7K5G/011P-3B	
28	35	26	<b>15</b>	25	<b>11</b>	45	420	55	XXXXX-02-011G-3B	<b>F3</b>
41	57	38.6	<b>18.5</b>	35	<b>15</b>	57	550	145	XXXXX-03-015G/018P-3B	
48	67	46	<b>22</b>	41	<b>18.5</b>	57	660	145	XXXXX-03-018G/022P-3B	
63.5	89	61	<b>30</b>	48	<b>22</b>	57	890	145	XXXXX-03-022G/030P-3B	
78	109	75	<b>37</b>	66	<b>30</b>	60	1114	290	XXXXX-04-030G/037P-3/B	<b>F4</b>
95	133	91	<b>45</b>	79	<b>37</b>	60	1140	290	XXXXX-04-037G/045P-3/B	
120	168	115	<b>55</b>	94	<b>45</b>	60	1200	290	XXXXX-04-045G/055P-3/B	<b>F5</b>
162	227	155	<b>75</b>	116	<b>55</b>	60	1440	350	XXXXX-05-055G/075P-3/B	
185	222	178	<b>90</b>	160	<b>75</b>	60	1940	350	XXXXX-05-075G/090P-3/B	
225	270	215	<b>110</b>	179	<b>90</b>	67	2200	570	XXXXX-05-090G/110P-3/B	
272	326	261	<b>132</b>	215	<b>110</b>	68	3300	685	XXXXX-06-110G/132P-3	<b>F6</b>
320	384	310	<b>160</b>	259	<b>132</b>	68	3850	685	XXXXX-06-132G/160P-3	
375	450	360	<b>200</b>	314	<b>160</b>	68	4100	720	XXXXX-07-160G/200P-3	<b>F7</b>
450	540	430	<b>220</b>	387	<b>200</b>	68	4600	720	XXXXX-07-200G/220P-3	
487	584	470	<b>250</b>	427	<b>220</b>	68	5100	720	XXXXX-07-220G/250P-3	
546	628	525	<b>280</b>	481	<b>250</b>	68	5782	1200	XXXXX-08-250G/280P-3	
624	718	600	<b>315</b>	550	<b>280</b>	68	6252	1200	XXXXX-08-280G/315P-3	<b>F8</b>
686	789	660	<b>355</b>	616	<b>315</b>	68	7866	1200	XXXXX-08-315G/355P-3	
760	874	730	<b>400</b>	671	<b>355</b>	68	9100	1300	XXXXX-09-355G/400P-3	<b>F9</b>
865	995	830	<b>450</b>	759	<b>400</b>	68	9900	1300	XXXXX-09-400G/450P-3	
950	1093	920	<b>500</b>	850	<b>450</b>	68	10500	1680	XXXXX-09-450G/500P-3	
1100	1265	1080	<b>560</b>	950	<b>500</b>	68	11500	1680	XXXXX-09-500G/560P-3	
1200	1380	1150	<b>630</b>	1060	<b>560</b>	68	12600	1680	XXXXX-09-560G/630P-3	

**Rated voltage 660/690V series**(following table)

Rated Value		General Load Application		Heavy Load Application		Noise Level	Heat Radiation	Air Volume	Model Code	Dimension
IN A	Imax A	ILd A	PLd KW	IHD A	PHd KW	dBA	W	m <sup>3</sup> /h		
22	44	21	<b>18.5</b>	18	<b>15</b>	57	550	290	XXXXX-04-015G/018P-6	<b>F4</b>
26	54	25	<b>22</b>	22	<b>18.5</b>	57	660	290	XXXXX-04-018G/022P-6	
35	64	33	<b>30</b>	27	<b>22</b>	57	890	290	XXXXX-04-022G/030P-6	
44	70	41	<b>37</b>	35	<b>30</b>	60	1114	290	XXXXX-04-030G/037P-6	
49	71	48	<b>45</b>	45	<b>37</b>	60	1140	290	XXXXX-04-037G/045P-6	
61	104	58	<b>55</b>	52	<b>45</b>	60	1200	290	XXXXX-04-045G/055P-6	
80	124	80	<b>75</b>	65	<b>55</b>	60	1440	290	XXXXX-04-055G/075P-6	
98	168	93	<b>90</b>	86	<b>75</b>	60	1940	350	XXXXX-05-075G/090P-6	<b>F5</b>
119	198	113	<b>110</b>	100	<b>90</b>	67	2200	350	XXXXX-05-090G/110P-6	
142	200	142	<b>132</b>	121	<b>110</b>	68	3300	350	XXXXX-05-110G/132P-6	
175	220	165	<b>160</b>	150	<b>132</b>	68	3850	350	XXXXX-05-132G/160P-6	
220	240	215	<b>200</b>	175	<b>160</b>	68	4100	720	XXXXX-06-160G/200P-6	<b>F6</b>
271	320	245	<b>220</b>	220	<b>200</b>	68	4600	720	XXXXX-06-200G/220P-6	
290	350	265	<b>250</b>	250	<b>220</b>	68	5100	720	XXXXX-06-220G/250P-6	
300	360	295	<b>280</b>	270	<b>250</b>	68	5782	1000	XXXXX-07-250G/280P-6	<b>F7</b>
330	360	325	<b>315</b>	300	<b>280</b>	68	6252	1000	XXXXX-07-280G/315P-6	
370	480	360	<b>355</b>	330	<b>315</b>	68	7866	1000	XXXXX-07-315G/355P-6	
430	520	420	<b>400</b>	385	<b>355</b>	68	9100	1300	XXXXX-08-355G/400P-6	<b>F8<sup>1)</sup></b>
470	655	455	<b>450</b>	430	<b>400</b>	68	9900	1300	XXXXX-08-400G/450P-6	
522	700	505	<b>500</b>	470	<b>450</b>	68	10500	1300	XXXXX-08-450G/500P-6	
590	800	571	<b>560</b>	555	<b>500</b>	68	11500	1300	XXXXX-08-500G/560P-6	
721	820	710	<b>630</b>	600	<b>560</b>	68	12600	1300	XXXXX-08-560G/630P-6	
900	1350	880	<b>800</b>	680	<b>630</b>	68	16000	1680	XXXXX-09-630G/800P-6	<b>F9<sup>1)</sup></b>
1160	1750	1115	<b>1100</b>	900	<b>800</b>	68	20000	1680	XXXXX-09-800G/1100P-6	<b>F10<sup>1)</sup></b>
1250	2000	1250	<b>1250</b>	1114	<b>1100</b>	68	26000	1680	XXXXX-09-1100G/1250P-6	
1350	2200	1400	<b>1400</b>	1250	<b>1250</b>	68	32000	1680	XXXXX-09-1250G/1400P-6	

**G** –Constant torque load application, **P** - (Square torque load application) ,/indicate apolegamy,- indicate that the item is not supported.

**Rated Value:** IN=Continuous and available rated current without load at 40°C. Imax=Maximum output current. Ten seconds are allowable at startup. Under other circumstances, the time depends on temperature.

**General load application:** ILdContinuous rated output current of P converters at ≤ 40°C. The overload current value is allowed to reach 120% of ILd in 1 minute out of every 5 minutes. The time depends on the drive temperature under other circumstances.

**Heavy Load Application:** IHDContinuous rated output current of G converters at ≤ 40°C. The overload current value is allowed to reach 150% of IHD in 1 minute out of every 5 minutes. The time depends on the drive temperature under other circumstances.

PLd=Typical motor power in the light load application. PHd=Typical motor power in the heavy load application.

1)= Contains 6 or 12 pulse rectifier power circuit, Specific to the order kind prevail.

## Derating

If there is any exist following conditions, the above continuous output current must be reduced (this process should be considered in the selection of design, Run at the same time can through the internal intelligent control in the process of operation under the condition of guarantee provides maximum output drive automatic optimization capacity reduction) :

1). Ambient temperature exceeded +40 °C (+104°F), 2). The drive is installed in more than 1000 m above sea level.

**Be careful:** The final reduction coefficient is the product of all the applicable reduction capacity coefficients.

### environment temperature drop

If the temperature range is +40...55 °C (+104...131 °F), Each increase of 1 °C (1.8 °F), The rated output current is reduced by 1% .

### Elevation drop capacity

Altitude at 1000 to 4000 m Height in(3300 to 13123 ft), Elevation of per elevation 100 m (328 ft), derating 1%.

To know more accurate derating, Please consult our professional staff.

**Be careful:** If the installation is higher than sea level 2000 m (6600 ft) above, The drive is not allowed to be

connected to the floating ground (IT) or to the power grid of the earth.

### Main technical data and specifications

Item		Specification and Technical Data	
Main power connection	Input voltage U1	220 ... 240V;380 ... 500V;660 ... 690V;220V/380V/660V ± 20%;signal/three-phase power	
	Input frequency f1	50...60Hz ±5%	
	Input voltage U2	0...U1(V)(The maximum output voltage equals the input	
	Input frequency f2	0-1000Hz(V/Fcontrol);0-500Hz (vector control)	
	Carrier frequency	2-12KHz(The device can intelligently and automatically make optimal adjustment according to load characteristics and drive temperature.)	
	Input voltage unbalance degree	Maximum: ±3% of rated inter-phase input voltage	
	Efficiency	≈98%(when operating at rated power)	
Basic functions	Input frequency resolution	Digital setting: 1RPM Analog setting: 0.025% of maximum RPM	
	Control mode	Open-loop V/Fcontrol Open-loop vector control (SVC)/close-loop vector control	
	Startup torque	150% @ 0.25Hz @ OpenLoop(open-loop control) 200% @ 0Hz @ CloseLoop(close-loop control)	
	Speed range	1:200 @ OpenLoop(open-loop control) 1:3000 @ CloseLoop(close-loop control)	
	Steady-speed precision	±0.5% @ OpenLoop(open-loop control) ±0.01% @ CloseLoop(close-loop control)	
	Overload capacity	Heavy load application: 60s at 150% rated current @40°C. The time depends on the drive temperature under other conditions. Light load application:60s at 110% rated current @40°C. The time depends on the drivetemperature under other conditions.	
	Torque boost	Automatic torque boost. Manual torque boost 0.1%-30%	
	V/Fcurve	Intelligent adaptive	
	V/Fseparation	Two methods: full separation, half separation	
	Acceleration and deceleration curves	straight-line or S-curve acceleration and deceleration method Two acceleration time values. The acceleration and deceleration time range:0.0s-650.00s	
	Simple PLCfunction	Achieve operationof up-to-16-stages speed(via built-in PLC or control terminals)	
	Built-in PID	Conveniently achieve the process control close-loop control	
	Automatic voltage regulation (AVR)	When the grid voltage changes, the device automatically maintainsconstant output voltage.	
	Overvoltage and overcurrent stall control	The current and voltage are automatically limited during running to avoid jump faults due to frequent overcurrent and overvoltage	
	Fast current limiting	Overcurrent faults are minimized to guarantee normal operation of the frequency converter.	
	Enhancements	Torque limiting and control	The torque is automatically limited operating (to avoid frequent overcurrent jumping fault due to too large torque).
		Protection function	Output shortcircuit protection, input & output phase loss protection, overcurrent protection, overvoltage protection,undervoltage protection, overheat protection, overload protection, brake chopper overload protection, brake chopper shortcircuit protection, brake resistor overload protection
Non-stop during transient interruption		Keep the frequency converteroperating in a short time (by reducing feedback energy compensation voltageat the moment of power outage). The duration depends on the mechanical inertia of the load at that time.	

Timing control	Timing control function. The time range and precision is 0.0-6500.0(min).
Switching multiple motors	Support switching among four groups of motor parameters.
Bus communication	The standard configuration uses the built-in Modbus/CANopen communication, which can be extended to Profibus-DP bus communication.
Intelligent temperature control	Full cover system temperature testing, intelligent real-time IGBT chip temperature monitoring, and intelligent and optimized adjustment of the carrier and current based on drive temperature changes
Type of encoders supported	Support differential encoders, collector open encoders, UVW encoders, rotary transformer encoders and Sin-Cos Encoders



Item		Specification and Technical Data
I/O Input/Output Interface	Command input mode	Control keyboard input, control terminal input, bus communication input, which can be switched mutually.
	Speed giving mode	Digital giving, analog voltage (current) giving, pulse giving, bus communication giving and PID giving, which are mutually switched.
	Input terminal (input)	<p>The followings are included in standard configuration:</p> <p>6(F0) / 7 (F1 and above) digital input terminals. where DI6 (F0) DI7 (F1 and above) supports the maximum of 50 kHz high-speed pulse input.</p> <p>2(F0) /3 (F1 and above) analog input terminals (where, at least 2 supports 0-10V voltage input or 0-20mA voltage input).</p> <p>The followings are extended as cards:</p> <p>5 digital input terminals</p> <p>2 analog input terminals, supporting input of -10V to +10V voltage</p>
	Output terminal (output)	<p>The followings are included in standard configuration:</p> <p>1 high-speed pulse output terminal (supporting 0-50 kHz square signal output)</p> <p>1(F0) /2(F1 and above) digital output terminals</p> <p>1 (F0) /2(F1 and above) relay output terminals</p> <p>1 (F0) /2 (F1 and above) analog output terminals (supporting 0-10V voltage output or 0-20mA voltage output)</p> <p>The followings are extended as cards:</p> <p>3 digital output terminals</p> <p>3 relay output terminals</p> <p>3 analog output terminals, supporting 0-10V voltage output or 0-20mA voltage output.</p>
Display and contro006C	Man-machine interface	5-bit 8-shape digital tube (F0), intelligent sealed LCD control keyboard (F1 and above)
	Parameters duplicating	Rapidly duplicating parameters via the LCD control keyboard
Application environment	Application site	Indoor, free of direct sunshine, dusts, corrosive gases, flammable gases, oil mist, water vapor, drip or salts.
	Altitude	At 0-1000m; When the altitude is 1000-4000m, the capacity is reduced by 1% as the altitude rises by 100m. (consult professionals for more accurate values).
	Operation ambient temperature	-10°C to +40°C (when the ambient temperature is 40°C-55°C, the drive is automatically derated to achieve self-protection).
	Relative humidity	Less than 95%RH. No droplets condensed (condensation)
	Sinusoidal vibration	(IEC 60068-2/-6. Test Fc) Max. 0.1mm (5 to 13.2Hz); max. 7m/s <sup>2</sup> (13.2 to 100Hz) sinusoidal vibration (F0-F7) Max. 0.1mm (10 to 57Hz); max. 10m/s <sup>2</sup> (57 to 150Hz) sinusoidal vibration (F8-F9)
	Impact	Not allowed (during operation); maximum 100m/s <sup>2</sup> , 11ms (during storage and transportation with packing).
	Free fall (Max.)	Not allowed (during operation); with packing: 100cm @ F0-2, 76cm @ F3-4, 46cm @ F5-7, 15cm @ F8-9.
	Storage & transportation temperature	-40°C to +70°C (-40 to +158°F).
Protection grade	IP20 (UL open type), full closed design for small- and medium-power models. Top/Left and right sides can reach IP41 (the medium cavity with air vents on two sides for some F0** models).	
Cooling mode	Forced air cooling of the interior fan. The air flows from bottom to top. Air-cooled radiator.	
Application standard	IEC 61800-3(2004); IEC 61800-5-1(2007); GB 12668; (see the nameplate for details).	

## Power cable size and fuse

Fuses for short circuit protection of power supply are shown in table below. In the presence of a short circuit, Fuse can also protect the adjacent equipment of the drive, Check the fuse action time is less than 0.5 seconds. The action time is determined by the power supply network's impedance as well as the cross-sectional area and length of the power supply cable. Please also refer to the electrical installation design Chapter. **Be careful: The use of a higher current rating of the fuse is strictly prohibited.** Fuse current as well as recommended suggest cable sizes are in the following table shown. Final choice should refer to the actual field application and fuse or cable installation conditions.

Dimension	Drive model single phase 220V~	Drivr rated current	Fuse rated current	Power supply and motor wire diameter (mm <sup>2</sup> )
		I <sub>N</sub> (A)	I <sub>E</sub> (A)	
F0,F1	0K4G/0K7P-1B	3	10	2.5
F0,F1	0K7G/1K5P-1B	4.8	10	4
F0,F1	1K5G/2K2P-1B	8	16	4
F0,F1	2K2G/4K0P-1B	10.5	20	6

Dimension	Drive model single phase 380V~	Drivr rated current	Fuse rated current	Power supply and motor wire diameter (mm <sup>2</sup> )
		I <sub>N</sub> (A)	I <sub>E</sub> (A)	
F0,F1	0K7G/1K5P-3B	3	10	2.5
F0,F1	1K5G/2K2P-3B	5	10	4
F0,F1	2K2G/4K0P-3B	6	16	4
F0,F1	4K0G/5K5P-3B	10	20	6
F1	5K5G/7K5P-3B	13	25	6
F2	7K5G/011P-3B	17	35	10
F2	011G-3B	25	35	10
F3	015G/018P-3B	32	50	10
F3	018G/022P-3B	37	50	16
F3	022G/030P-3B	45	63	25
F4	030G/037P-3/B	60	80	25
F4	037G/045P-3/B	76	100	35
F4	045G/055P-3/B	90	125	35
F5	055G/075P-3/B	110	160	60
F5	075G/090P-3/B	150	200	60
F5	090G/110P-3/B	176	250	90
F6	110G/132P-3	210	315	90
F6	132G/160P-3	260	315	120
F7	160G/200P-3	305	400	180
F7	200G/220P-3	380	500	2*120
F7	220G/250P-3	426	500	2*120
F8	250G/280P-3	480	630	2*150
F8	280G/315P-3	520	630	2*150
F8	315G/355P-3	600	800	2*150
F9	355G/400P-3	650	800	2*180
F9	400G/450P-3	720	1000	2*270
F9	450G/500P-3	820	1000	2*270
F9	500G/560P-3	900	1250	2*270
F9	560G/630P-3	1100	1250	2*270

Notes: For the above-mentioned guidelines about 660/690V series machines, please refer to the general professional electrician manual, People or consulting our representative to get support.

## Material introduction

---

- Drive structure**
- ABS/PA66, colour RAL 9002(light gray) / RAL9004(black)
  - Hot dip galvanized steel sheet / cold rolled steel plate + Spray
  - Stamping aluminum Al/6063
  - red copper T2
  - PC chip/ epoxy glass cloth plate / high performance PP chip

**packaging** Corrugated box / glued wood, EPE cushion, PP bandage/ adhesive tape

**disposal** The raw materials used are recyclable, This can save energy and natural resources. Packaging materials are biodegradable and recyclable. All metal parts can be recycled.

Plastic parts can be recycled or according to local laws and regulations in a controlled environment destroyed. Most recyclable parts have a marked that can be recycled. If can't carry out recycle, All components except the electrolytic capacitor and the printed circuit board can be treated with the method of burying. Electrolyte contained in a DC capacitor, EU The standard is inside classified as hazardous waste. The electrolytic capacitor and the printed circuit board must be processed in accordance with the local regulations.

To learn more about environmental conditions and waste recovery aspect For more information, please contact our local representative office.

## ■ 9. EMC Electromagnetic Compatibility Guide and CE mark

If there are CE mark on drive, Indicates that the drive is in compliance with the provisions of the European low voltage and EMC directive.

**Follow the EMC international standard:** The cabinet manufacturer is responsible for the drive system to meet the requirements of the European EMC directive. Relevant items to be considered, see also: Standard EN 61800-3 (2004), C2 Class, satisfying criteria EN 61800-3 (2004), C3 C3 class and satisfying criteria EN 61800-3 (2004), C4 Class section.

### Electromagnetic compatibility definition

Electromagnetic compatibility is the limited time for the use of electrical equipment, Space and spectrum resources can coexist under the conditions, Does not cause performance degradation. equipment, subsystem, System should not generate more than the electromagnetic emission requirements stipulated in the specification or standard, And can meet the requirements of immunity. EMC Represents an electromagnetic compatibility. Electromagnetic compatibility is used to indicate the ability of the electrical and electronic equipment to work properly in electromagnetic environment. conversely, Equipment also does not respond to local other devices or systems to release electromagnetic interference.

The first environment includes civilian facilities. Also not through intermediate transformer connected directly to the facilities for civil building power supply of low voltage power grid. Second environment includes in addition to the direct connection to the power supply of low voltage power grid for civilian buildings outside the facility.

C2 class driver. The rated voltage of electric drive system is lower than 1000 V, Can be a plug-in device or mobile device, When used in the first environment can only be used by professionals to carry on install and debug.

C3 class driver. The rated voltage of electric drive system is lower than 1000 V, Applicable to the second environment, Does not apply to the first environment.

C4 class driver. The rated voltage of electric drive system is lower than 1000 V, Or the rated current is not less than 400 A, Or suitable for complex systems with second environments

### Introduction of EMC standard in China

According to the requirements of China national standard GB/T12668.3, The driver needs to meet the requirements of electromagnetic interference and electromagnetic interference in two aspects. We existing products perform are the latest international standards: IEC/EN61800-3: 2004 (Adjustable speed electrical power drive systems part 3: EMC requirements and specific test methods) Equivalent national standard GB/T12668.3.

IEC/EN61800-3 Mainly from two aspects of electromagnetic interference and electromagnetic interference on the drive to investigate, Electromagnetic interference mainly to drive radiated interference, Test of conducted interference and harmonic interference (The corresponding drive for civil use has this requirement.). Anti electromagnetic interference is the main driver of the conductive immunity, radiated immunity, Surge immunity, Fast mutation impulse group immunity, ESD immunity and low frequency power supply noise immunity (Specific test items are: 1、 Input voltage sag, Disruption and variation of immunity test; 2、 The Phase change commutation gap test; 3、 Harmonic input immunity test; 4、 Input frequency variation test; 5、 Input voltage unbalance test; 6、 Input voltage fluctuation test) carry testing. According to the above IEC/EN61800-3's strict requirements for carry testing, Our products as shown in below carry guidance for installation, In the general industrial environment will have good electromagnetic compatibility.

### EMC guide

#### Influence of harmonics

High order harmonics of the power supply may cause damage to the driver and its peripheral electrical equipment, Where the power quality is poor The proposed installation of AC input reactor or current harmonic filter.

Due to the influence of harmonics, Input leakage circuit breakers are selected with reference to the main circuit input side connection description.

Drive motor power cable contains higher harmonic current, So it may cause the thermal relay malfunction due to resonance, Need to reduce the carrier frequency or the installation of output reactor. It is recommended to use the drive motor before don't add thermal relay, While the use of the drive over current protection function.

#### Electromagnetic interference and installation considerations

1. Other electrical products be grounded line should be good grounding. When using EMC filter, Must permanent fixed ground connection must be used, This kind of connector is not transferred through the connector.

2. Drive input and motor power cable and weak current signal (Such as control signal cable) As far as possible separated from each other. If there is potential weak signal line using the metal wire cable slot separate wiring.

3. Drive input and motor power cables are recommended for use in shielded cables, Or use armored cable. Both ends of the cable shielding layer or armored need reliable grounding. The shielding twisted pair is recommended for the weak signal line which is easy to be disturbed, Reliable grounding and shielding layer.

## 9. EMC Electromagnetic Compatibility Guide with CE markers

4. For the motor cable length of more than 100 m, Requires the installation of an output filter or reactor.

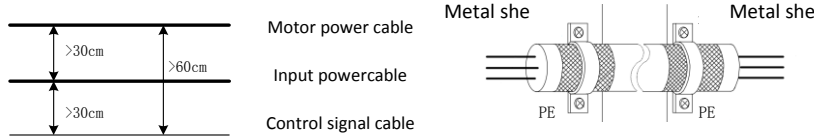

## Wiring requirements and shielding grounding method

### Ground

1. Drives and other equipment are recommended to be grounded separately; If you need any common ground, Need a single point grounding. Do not recommend a common ground wire.
2. The grounding cable of the section, should choose as far as possible big, To ensure that the grounding impedance is as low as possible. Due to the same cross-sectional area of the cable, The high frequency impedance of the flat conductor is smaller than that circular conductor is smaller, So choose flat cable is better. Earthing cable should be as short as possible, The ground should be as close to the drive as possible.
3. Motor power cable, such as the use of 4 core cable, The ground wire in the 4 core cable must be grounded on the drive side, On the other side is connected to the ground terminal of the motor; If the motor and drive each have a dedicated access location the best grounding effect can be obtained.
4. If the control system of the various components of the grounding end together, The formation of the earth leakage current noise source will affect other peripheral device driver control system in and abroad. So in the same control system, Drives and weak devices such as computers, Sensor or audio and other equipment to the ground to be separated, Can't be connected together.
5. In order to obtain a lower high frequency impedance, The fixing bolt of each device can be used as the high frequency terminal connected with the rear panel of the cabinet, When installing, please pay attention to the insulation paint to remove the fixed point.
6. Laying the grounding cable should be far away from the wiring of the I/O part of the noise sensitive equipment, At the same time pay attention to the ground wire should be shortened.

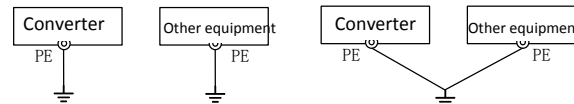

### Drive and other devices in a proper grounding mode

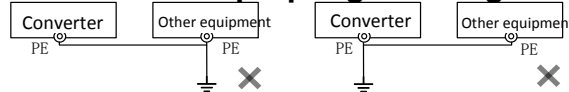

### Drive and other devices are not recommended in the ground mode

### Method for processing the electromagnetic interference generated by the peripheral electric equipment to the driver

Relay in drive peripheral environment, Contactor、 Electromagnetic brake, etc. may produce electromagnetic interference. When there is electromagnetic interference misoperation of drive , Suggested using the following method:

1. Produce surge suppressor device with interference;
2. Drive input power cable to add EMC filter;
3. Drive control signal and detection circuit using shielded wire or twisted pair, For shielding the shielding layer of the need for reliable grounding (360 degree ring).

### Processing method for electromagnetic interference generated by the driver to peripheral equipment

Drive on the peripheral equipment can be divided into two types of electromagnetic interference, A class of conduction interference, A class of radiation interference. According to different interference conditions, Reference to the following methods:

1. Used for measuring instruments, Meter、 Receiver and sensor signal is generally weak signal, If the and drive distance is near or in the same control cabinet, Is prone to interference and produce false action. Suggested that weak current signal away from disturbance sources as far as possible; Don't weak current signal wire and power cable tied together; Signal lines using shielded wire or twisted pair, shielded wire the Shielding layer needs a good grounding (As far as possible 360 degree ring); Power cable increase ferrite beads (nickel zinc copper, restrain frequency interference in more than 30MHz) And around 2~3 turns, In order to get better results can also be used EMC filter.
2. When the interference device and the driver use the same power supply, Easily lead to conductive interference, It is recommended to drive the input port increases EMC filter;

3. Peripheral equipment alone ground , Common mode interference caused by common ground impedance can be reduced.

### Leakage current and treatment

Distributed capacitance between power cable and earth, The longer the power cable is, the larger the distributed capacitance between the earth and the earth, The bigger the leakage current; The higher the carrier frequency, the greater the leakage current. Can shorten the power cable length and reduce the carrier frequency to reduce leakage current. But reducing the carrier frequency can lead to the increase of motor noise, Need to seek balance between the two.

### Power input EMCfilter to add attention

1. Please use the filter strictly in accordance with the rated value; Because the filter is a kind of I electrical equipment, The metal case must be large area and install ark metal to good contact, And the requirements of a good grounding continuity, Otherwise there is a risk of electric shock and a serious impact on the effect of EMC.
2. PE filter must and drive side received the same common ground, Otherwise it will seriously affect the EMC effect.
3. In the cabinet, The installation position of the filter should be close to the entrance end of the input power cable, And the power input line of the filter should be as short as possible in the control cabinet.
4. If the filter input line and output line laying too close, The high frequency interference will bypass the filter, Directly through the filter of input line and output line directly coupling, Make the power filter out of action.
5. The outer shell of the filter usually has a special ground terminal. But if the filter is connected to the control cabinet with a wire,

For the high frequency interference is equal to the dummy. This is because the high frequency impedance of long wire is very large, Can not play an effective bypass role. The correct installation method is a large area of the filter housing is pasted on the conductive plane of the metal casing, Please pay attention to the removal of insulation paint, Ensure reliable connection.

## EMCfilters

### When do you need the EMCfilter?

EMC product standard (61800-3 EN + all revised (2000)) Covered within the eu to drive (test with electric motors and cables) Describes the specific EMC requirements. 61800-3 (2004) A new version of the product standard can be used from now on, But at least since October 1, 2007. EMC standards such as EN 55011 or 61000-6-3/4 EN are applicable to industrial and civil equipment and systems containing drive components. The drive equipment which meets the requirements of 61800-3 EN is consistent with the requirements of EN 55011 and 61000-6-3/4 EN, But otherwise it may not be consistent. EN 55011 and EN 61000-6-3/4 was prescribed length of cable, Also do not need to connect the motor as the load. The following table is a comparison of the standard radiation limits.

EMC General standard		
EN61800-3/A11 (2000), Product standards	EN 61800-3(2004), Product standards	EN55011, Industrial, scientific and medical (ISM) Equipment product family standard
First environment, nonlimiting sales	C1class	Group1 categoryB
First environment, Limited sales	C2class	Group1 categoryA
Second environment, non limitingsales	C3class	Group2 categoryA
Second environment, Limited sales	C4class	not applicable



**Warning!** If the drive is connected to the IT system (i.e., ungrounded, or high resistance grounding (more than 30 Ohm) Power supply system), Is prohibited to install EMC filter.

### Installation guide

- The filter is directly connected to the input terminal of the driver.
- In order to achieve the working best performance, the drive and the filter must be mounted on the same conductive surface.

### How to disconnect the built-in EMC filter with ground screw

When the system needs to reduce the EMC protection grade or reduce to ground leakage current, user can choose to disconnect the built-in EMC filter of the grounding screw, the specific method for:

**F1-F3 series models:** Unscrew the EMC position screw on the drive body as shown.

**F4 and above models:** Find EMC capacitor location mark After open cover, Remove the earthing short connection cap.

**be careful!** After changing the EMC level, please use glue to stick mark on the drive frame, And record the date. Tag suggestions posted on the nameplate side.

**be careful!** F4 and more models to change the driver's EMC protection level due to the need to open some of the chassis, So the proposal is completed by the professional service personnel.

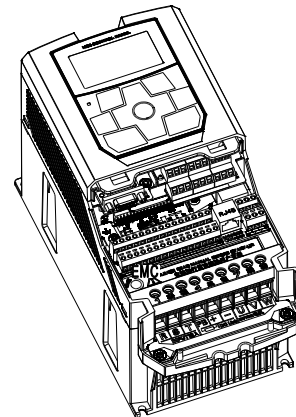

## 9. EMC Electromagnetic Compatibility Guide with CE markers

## ■ 10.Input reactor

Contents of this chapter

This chapter describes how to select and install the input reactor.

### When needs to input reactor?

The Dimension as F3-F9 driver module has a built-in input reactor. For the dimensions F0 and F2, whether to need external reactor should accord to particular case. Input reactor is mainly used to

- Reducing harmonic in input current
- Reduced RMS input current
- Reducing power supply interference and low frequency interference
- Increase the allowable DC bus continuation power
- The average current distribution in the common DC bus is guaranteed.

### Input reactor type selection recommended value can refer to the next section [du/dt or common mode filter] Table data.

#### Installation guide

- If you need to install EMC, the input reactor is connected between the power supply and the EMC filter. Please refer following picture.
- In order to achieve the best effect of the reactor work, The drive and the reactor must be installed on the same conductive base plate.
- Make sure that the reactor does not block the flow of air through the drive, and the hot air produced by the reactor should separate from the air inlet of the drive module.
- Keep the cable between the drive and the reactor as short as possible.



**Warning !** In this condition using, the surface of the reactor will be hot

#### Wiring diagram AC power

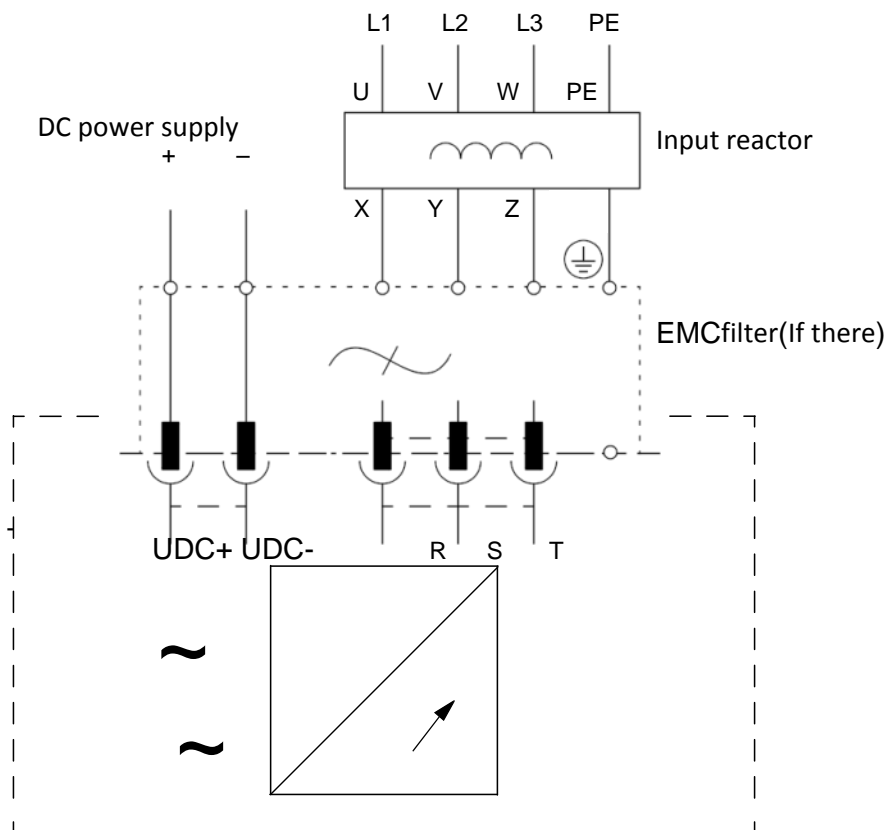

## ■ 11.du/dt and common mode filtering

### When do we need du/dt or common mode filtering?

No matter how much the output frequency is, the output of the drive contains a very short rise time, about 1.35 times pulse the equal supply voltage. This is all the characteristics of the drive using IGBT inverter technology. The pulse voltage is two times of the voltage at the terminal of the motor, which is related to the attenuation and reflection characteristics of the motor cable and terminal. It puts forward higher requirements for the insulation of the motor and its cable. A fast rising voltage pulse and high switching frequency are the features of the modern drive speed control unit produced by the current pulse flowing through the motor bearing. It will gradually damage the bearing ring and rotating parts. The use of du/dt filter can reduce the requirements of the motor insulation. Du/dt filter can also reduce the bearing current. Common mode filter is mainly used to reduce the bearing current. The input reactor can suppress the high order harmonics of the input current of the driver, significantly improving the drive power factor, reducing RMS input current, Reduce power supply interference and low frequency interference. The output reactor can increase the output high frequency impedance, reducing high frequency leakage current, protecting drive, effectively reducing the high IGBT output of du/dt, prolonging motor life, suppressing the harmonic current of the output of the drive, compensating long line distribution capacitance, extending the output output distance, reducing the noise of the motor.

The following is an AC input / output reactor recommended selection table:

Drive model	AC input reactor		AC output reactor	
	Electriccurrent(A)	inductance(mH)	Electriccurrent(A)	inductance(mH)
0K7G/1K5P-3B	4.8	4.8	6	3.4
1K5G/2K2P-3B	6.2	3.2	6	3.4
2K2G/4K0P-3B	9.6	2	10	1.2
4K0G/5K5P-3B	14	1.5	18	0.5
5K5G/7K5P-3B	18	1.2	18	0.5
7K5G/011P-3B	27	0.8	26	0.35
011G/015P-3B	34	0.6	34	0.25
015G/018P-3B	41	0.5	47	0.2
018G/022P-3B	52	0.42	47	0.2
022G/030P-3B	65	0.32	60	0.25
030G/037P-3/B	80	0.26	75	0.23
037G/045P-3/B	96	0.21	90	0.16
045G/055P-3/B	128	0.18	112	0.16
055G/075P-3/B	165	0.13	150	0.11
075G/090P-3/B	195	0.11	176	0.01
090G/110P-3/B	224	0.09	210	0.01
110G/132P-3	262	0.08	250	0.08
132G/160P-3	302	0.06	305	0.07
160G/200P-3	340	0.06	377	0.056
200G/220P-3	420	0.05	415	0.053
220G/250P-3	470	0.04	520	0.038
250G/280P-3	530	0.04	520	0.038
280G/315P-3	605	0.04	630	0.031
315G/355P-3	660	0.03	800	0.03
355G/400P-3	750	0.03	800	0.03
400G/450P-3	1000	0.025	1000	0.025
450G/500P-3	1000	0.025	1000	0.025
500G/560P-3	1200	0.011	1200	0.011
560G/630P-3	1200	0.011	1200	0.011

Notes : Refer to the general professional electrical manual for the 660/690V series models, People or consulting our representative to get support.

### 11.du/dt and common mode filtering



## ■ 12. Resistance Brake

Contents of  
 this chapter

This chapter describes how to select, protect and connect the brake chopper and resistance.

### Brake chopper and resistor

#### Brake chopper

This series (dimension F0-F5) has brake chopper driver with built-in or optional built. Used for consume the energy motor slowdown produced.

When the brake chopper is activated and connected to the resistance, the brake chopper will start the action since the DC circuit voltage of the driver reaches the brake voltage.

#### Braking resistor selection:

1. The maximum power of calculation in the process of braking motor.
2. The continuous power is calculated according to the duty ratio of the brake.
3. Calculate the work cycle of generated braking energy.
4. Can choose to customize the resistance, meeting the built-in brake chopper caused by some of the restrictions requirement. rules are as follows:

The following table is only for the guidance data, user can choose according to working condition of field using different resistance tolerance and power (But the value can not less than the recommended value shown in the table, power can be large). The selection of braking resistance is based on the greater inertia of the system, the shorter deceleration time, the greater braking rate, the resistance should be small, Power should be take big

The selection of resistance

According to the formula:  $R=U^2/P$

U: Brake action voltage:

**380/400VAC System default settings 750VDC,**  
**660/690VAC System default settings 1150VDC,**  
**220VAC System default settings 375VDC**

P: For the braking power

Selection of resistance power

In order to ensure the safe use of brake resistance, It needs to reduce the amount of 70% to use.

According to the formula:  $Pr=P*D/0.7$

D: Brake rate (braking process accounts for the proportion of the whole system work cycle)

D reference selection of value

General working conditions: 10%-15%

Elevator: 25%-35%

Lifting or centrifugation: 50%-60%



**Warning!** For a particular type of drive, do not use the brake resistance that is less than the specified resistance value. The drive and chopper can not be protected against the over current of the small resistance.

- The braking energy shall not exceed the energy dissipation capacity of the selected resistance
- It is strongly recommended that the resistance is protected against thermal overload.

**Chopper data / resistance selection guidance data sheet**, the rated value is applicable to ambient temperature 40°C (104°F) situation .

The models and applications are not listed here. Please consult the professional or a representative of our company.

Driver model	Braking frequency of 20% recommended braking resistance tolerance (Ω) general applications	Braking frequency of 20% recommended braking resistance power (W) general applications	Connecting resistance wire diameter(mm <sup>2</sup> )
0K4G/0K7P-1B	≥200	≥100	1
0K7G/1K5P-1B	≥150	≥200	1.5
1K5G/2K2P-1B	≥100	≥400	1.5
2K2G/4K0P-1B	≥75	≥500	2.5

Driver model	Braking frequency Of 20% recommended braking resistance tolerance(Ω)general applications	Braking frequency of 20% recommended braking resistance power (W)general applications	Braking frequency of 50% recommended braking resistance power and tolerance(W/Ω) Heavy load application such as Hoist	Connecting resistance wire diameter(mm <sup>2</sup> )
0K7G/1K5P-3B	≥300	≥200		1
1K5G/2K2P-3B	≥150	≥400		1.5
2K2G/4K0P-3B	≥150	≥400		1.5
4K0G/5K5P-3B	≥100	≥800	2000W/100 Ω	2.5
5K5G/7K5P-3B	≥75	≥800	3000W/75 Ω	4
7K5G/011P-3B	≥75	≥1000	4000W/75 Ω	4
011G/015P-3B	≥40	≥1000	6KW/50 Ω	6
015G/018P-3B	≥40	≥1500	7.5KW/40 Ω	6
018G/022P-3B	≥30	≥1500	9KW/30 Ω	6
022G/030P-3B	≥25	≥1500	11KW/30 Ω	10
030G/037P-3/B	≥22	≥3000	15KW/14 Ω	10
037G/045P-3/B	≥14	≥4000	18KW/14 Ω	16
045G/055P-3/B	≥14	≥5500	22KW/7 Ω	16
055G/075P-3/B	≥8	≥8000	28KW/4.8 Ω	35
075G/090P-3/B	≥8	≥12000	38KW/4.8 Ω	35
090G/110P-3/B	≥8	≥16000	46KW/4.8 Ω	35

Notes: For the above-mentioned guidelines about 660/690 v series drive manual, please refer to the general professional electrician. People or consulting our representative to get support.

## Resistance installation and connection

All resistors must be installed outside of the drive module, installation position to ensure that the full cooling. Don't block the flow of other equipment. Do not let the hot air distributed to other equipment in the air inlet either.



**Warning!** The material near the brake resistance must be flame retardant. Resistance of the surface temperature may raise to 200 °C (400°F) above. The airflow through the resistance temperature can reach several hundred degrees Celsius. The material must be prevented from contacting resistance.

The maximum length of the brake resistance cable is 20 meters (65 ft).

## 12. resistance braking

## Drive's contactor Protection

For security reasons, it is strongly recommended to install a main contactor for the drive. Contactor can be uncoupled when the resistance overheats. This is very important for security. If the chopper is still conducting in the case of a fault, the drive cannot be disconnected from the main power supply in other ways.

## Brake Circuit Debugging

For more information, please refer to the corresponding firmware manual.

- Enable brake chopper function. Please note that, After the chopper is enabled, the brake resistance must be connected
- Close the over voltage control of the drive



**Warning!** If the drive is fitted with a brake chopper and the chopper is not set up by the parameter settings, braking resistor must be disconnected. Because this time there is no protection of resistance overheating.

## ■ 13. Dimensional Drawing

Contents of this chapter

The dimensions of the series and related accessories are shown below.

The unit in the drawings is mm.

### Control keyboard and bracket shape and the installation dimensions

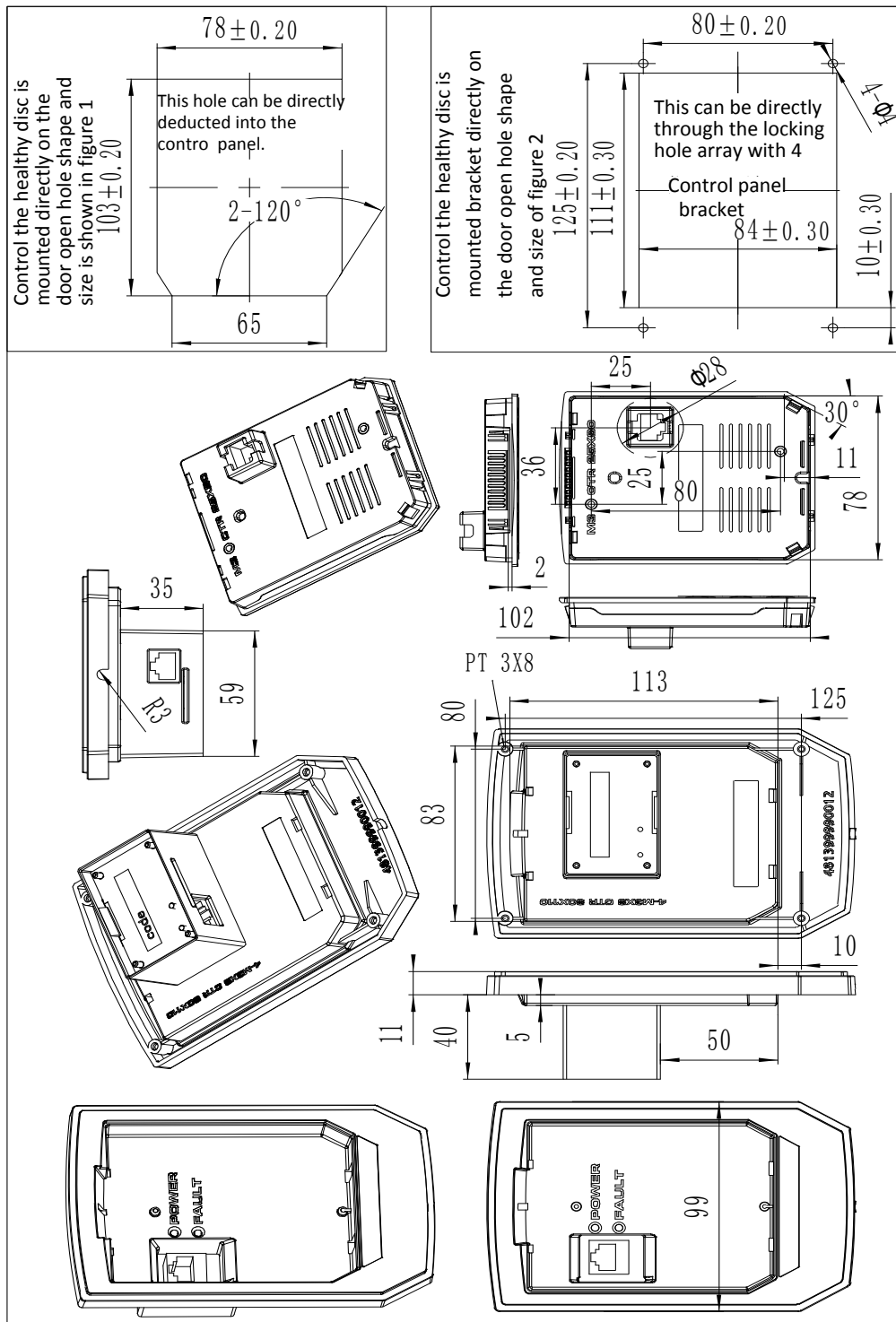

### 13. dimensional drawing

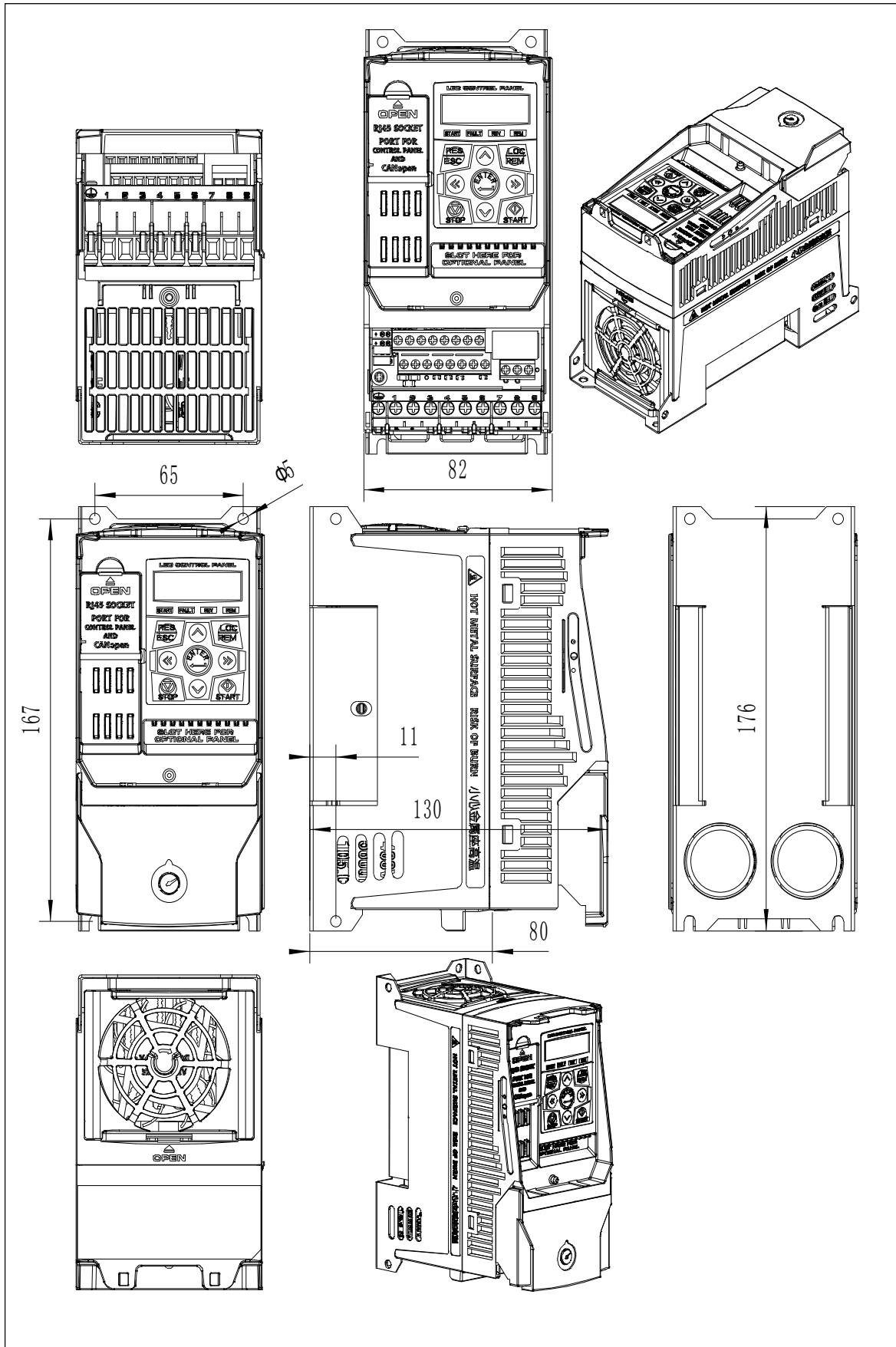

### 13. dimensional drawing

**F1,F2,F3 Outline and Size Chart**

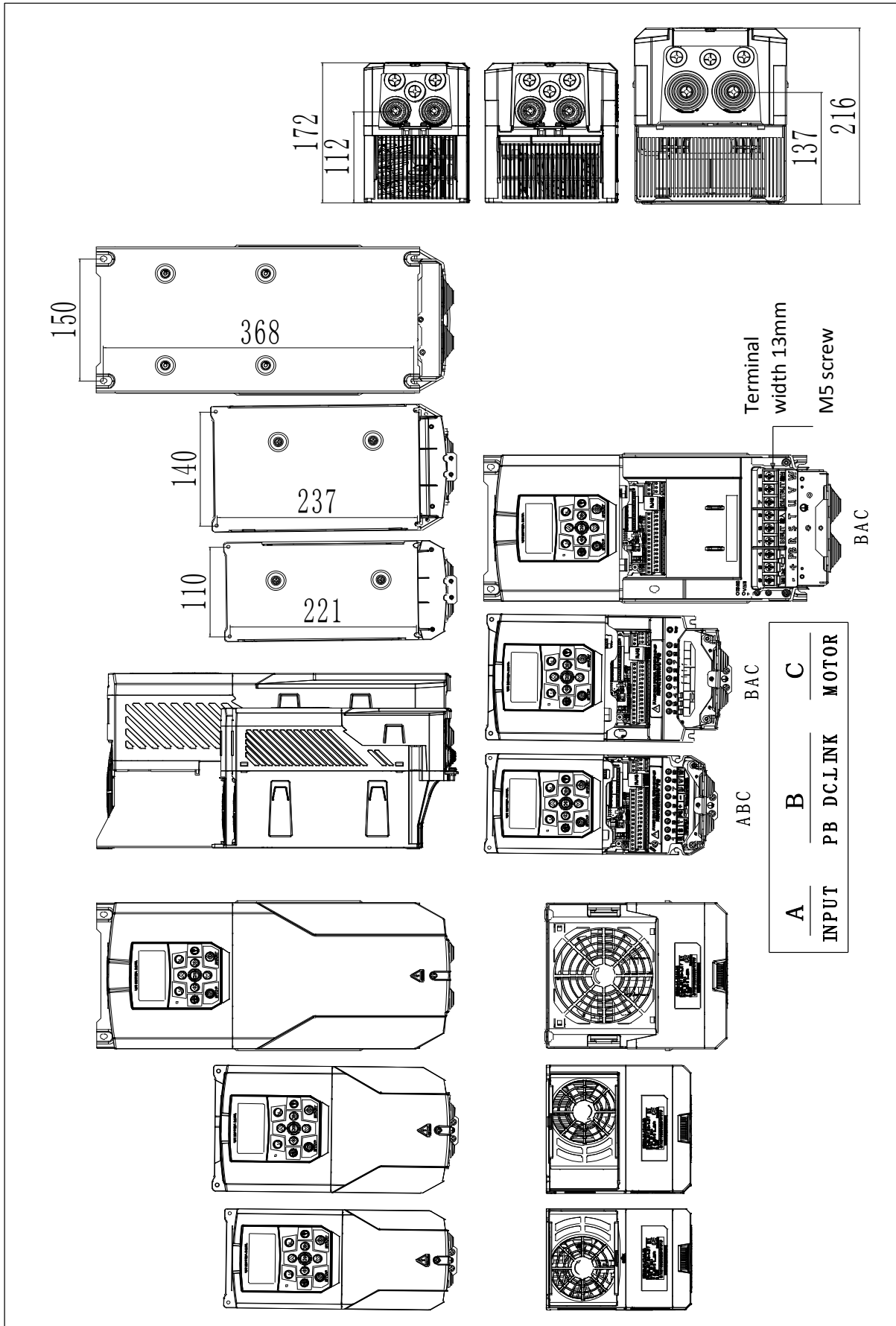

**F4 Outline and Size Chart**

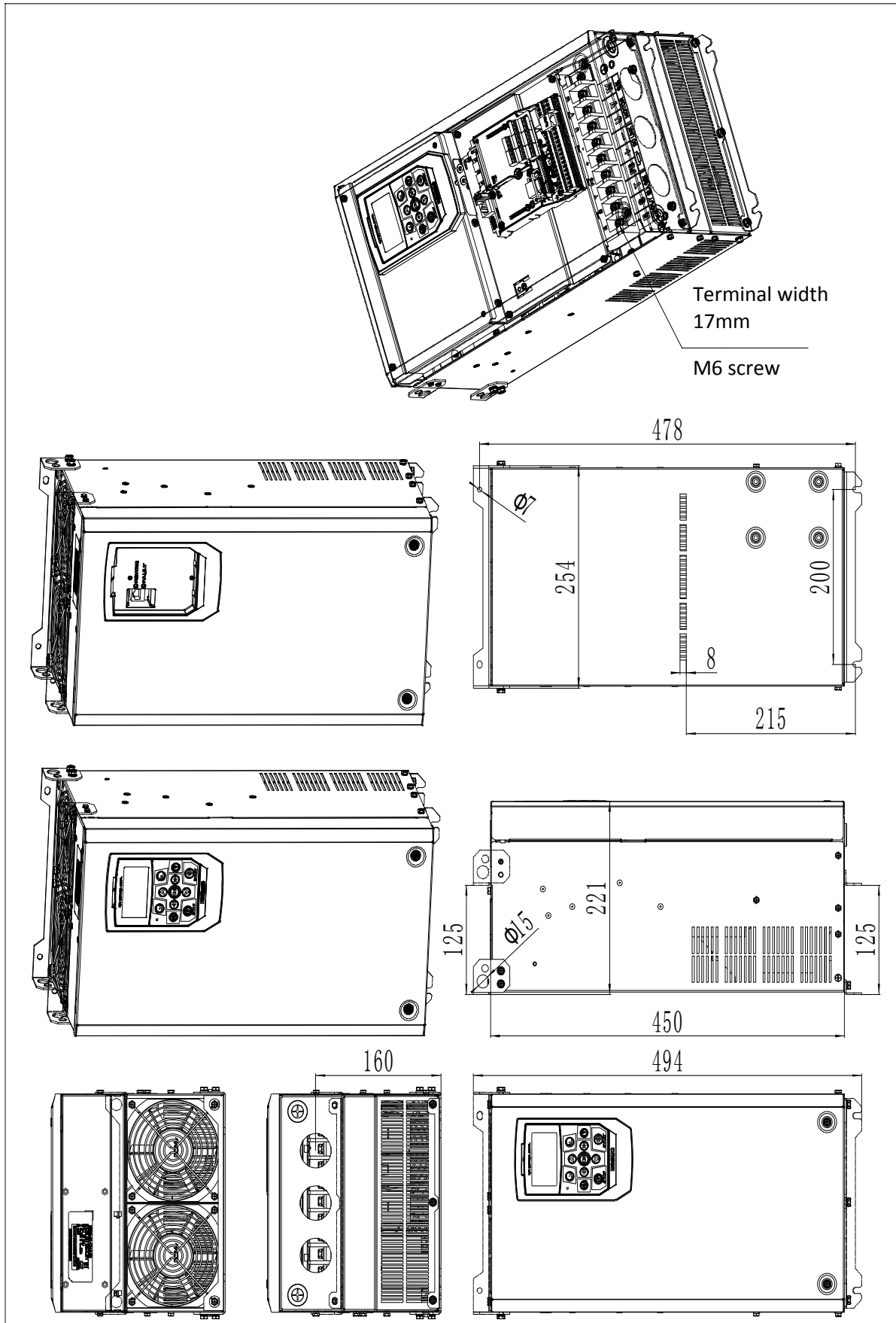

**13. dimensional drawing**

**F5 Outline and Size Chart**

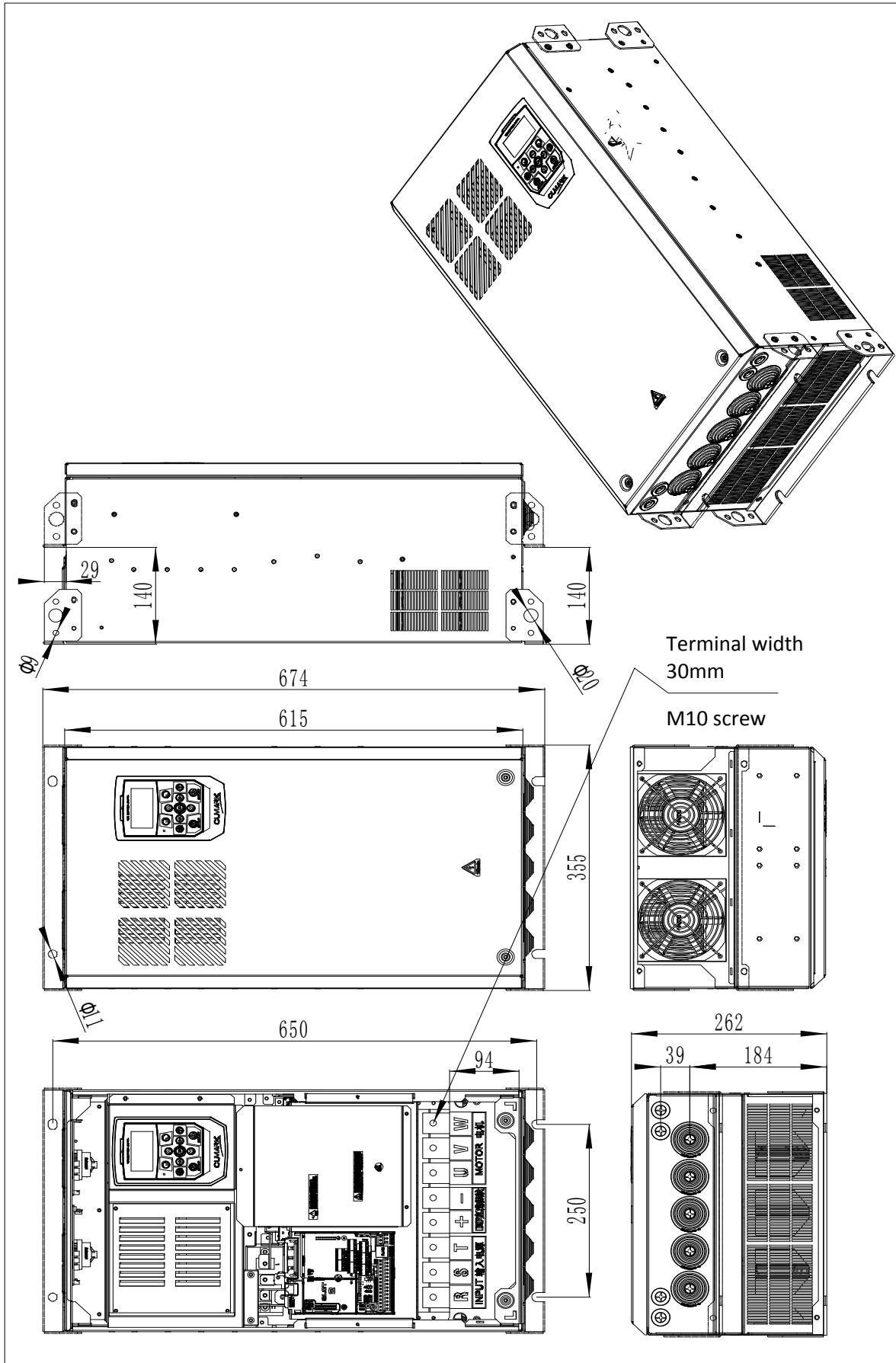

**13. dimensional drawing**





## F7 Outline and Size Chart

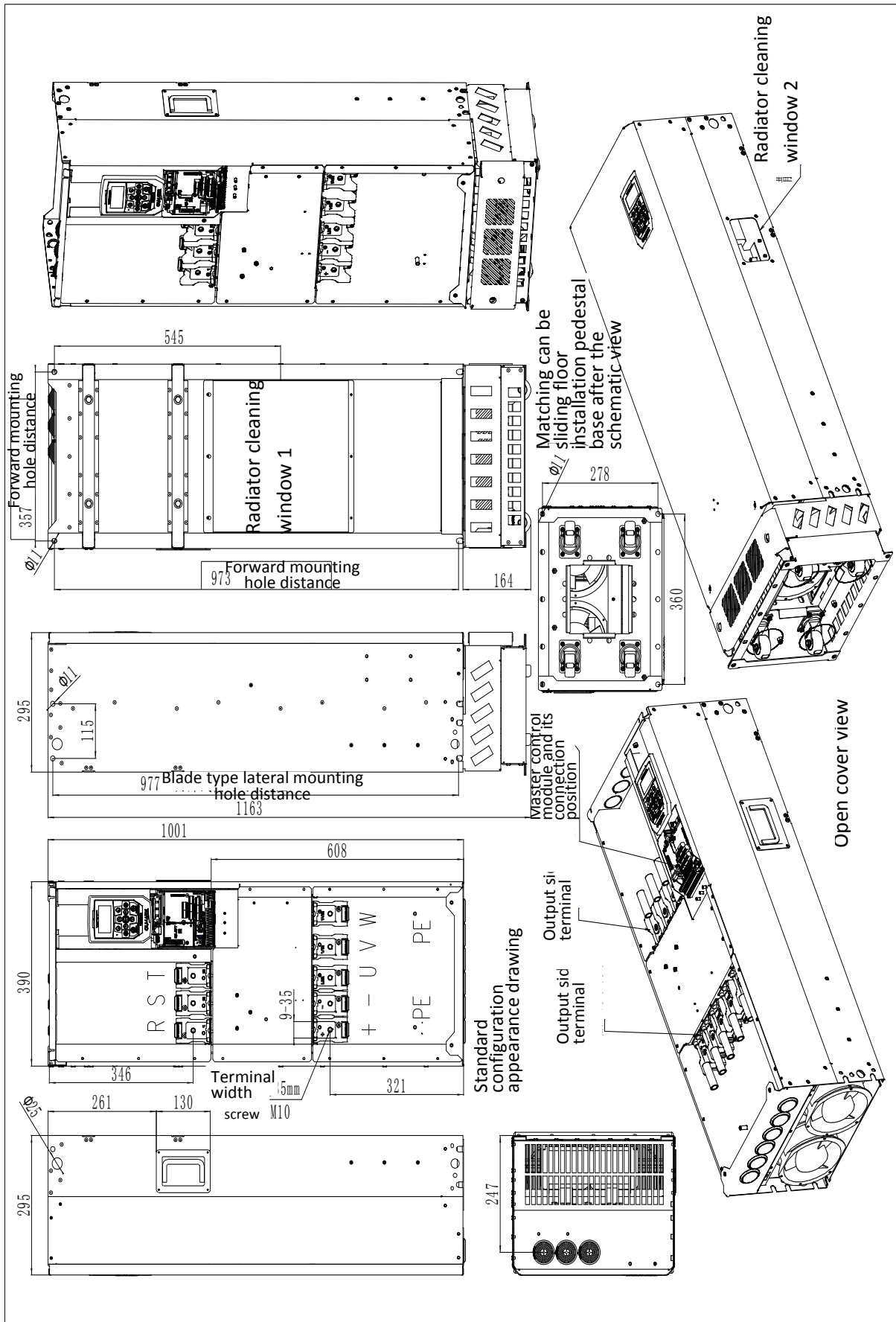

### 13. dimensional drawing

## F8 Outline and Size Chart

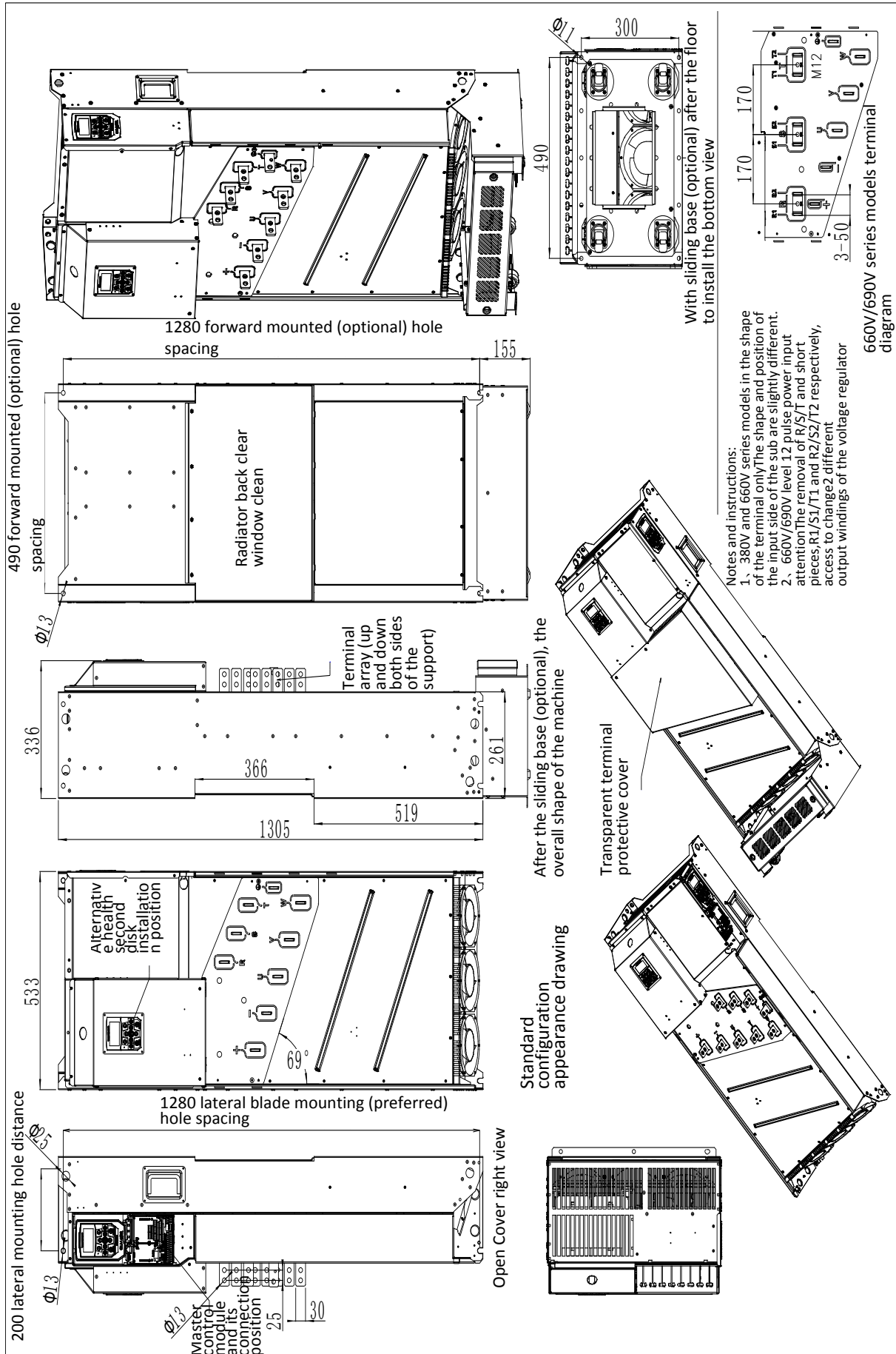

### 13. dimensional drawing

## F9 Outline and Size Chart

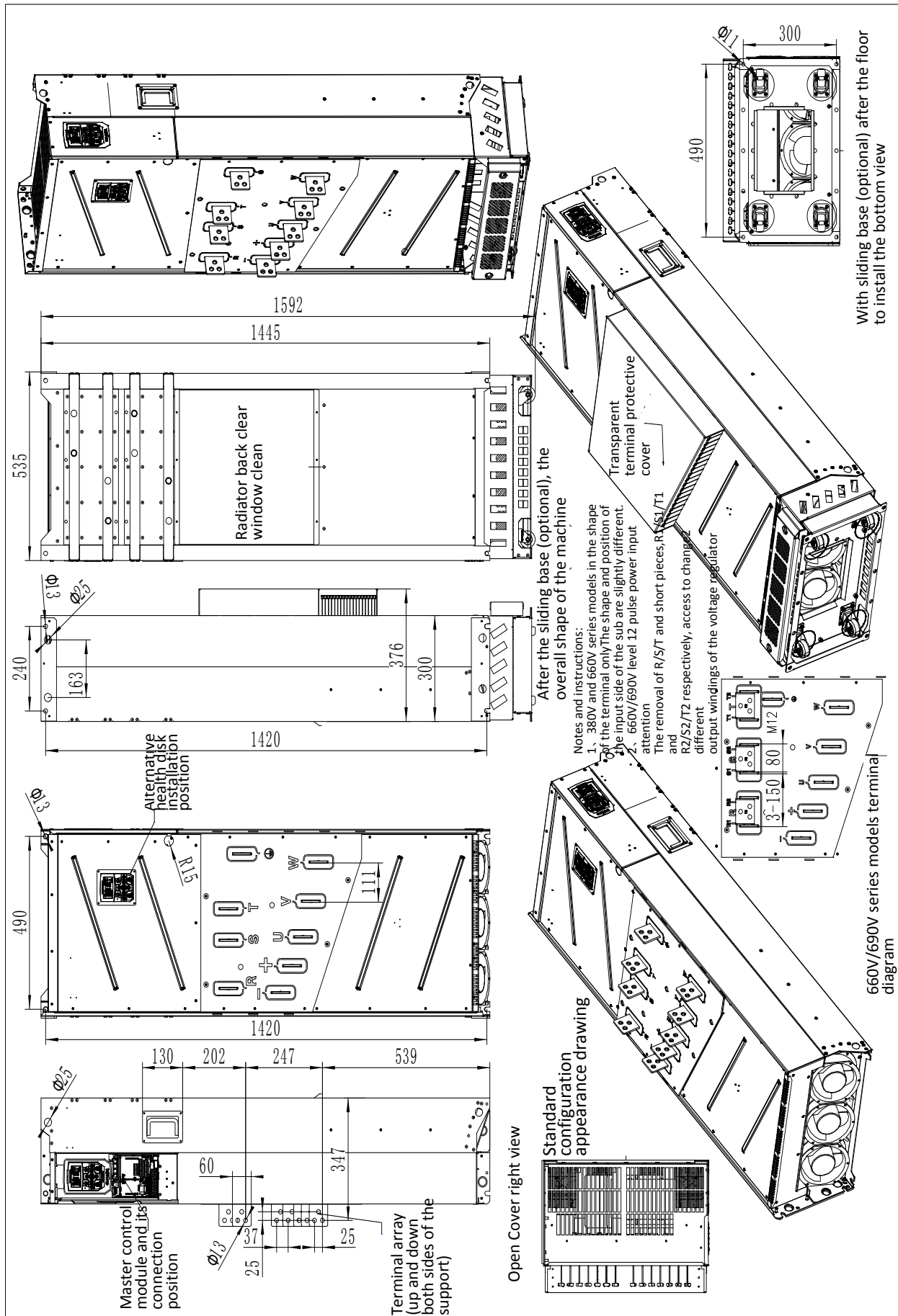

### 13. dimensional drawing



## Product Warranty Card

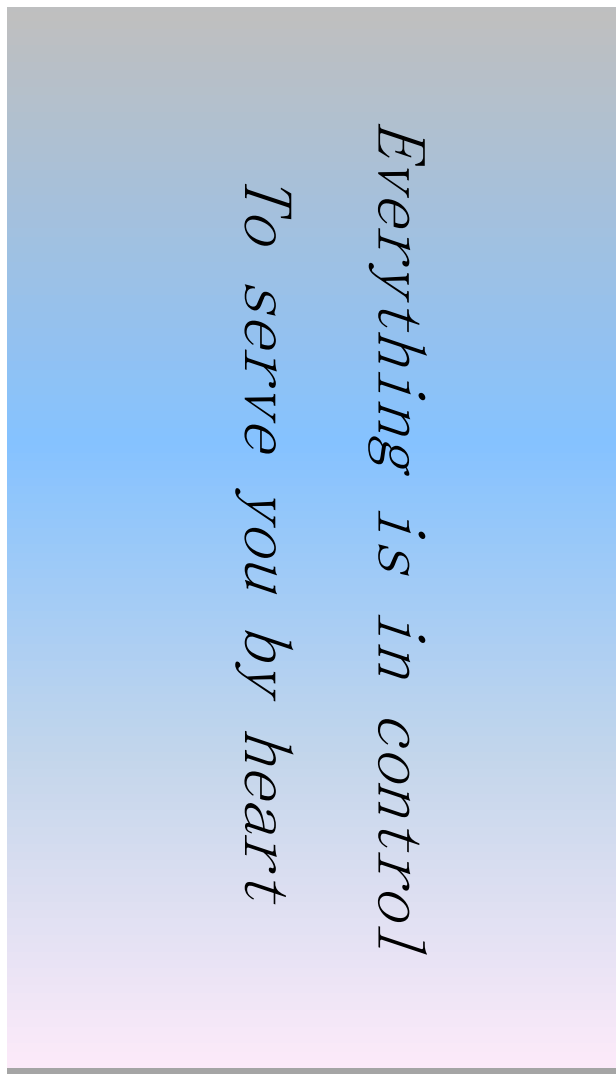

User Info	User address:	
	Name of user:	Contacts:
	Contact number:	Zip code:
On-product Information	Product model:	
	Product barcode:	
	Distributor:	
Fault Information	Fault description:	
	Fill in person:      date:      year    month    day	
Service Quality Evaluation	<input type="checkbox"/> good <input type="checkbox"/> preferably <input type="checkbox"/> general <input type="checkbox"/> difference More evaluation content:	
	Fill in person:      date:      year    month    day	

**Certificate (OQC Card)**

**Inspection conclusion :** This product has passed the inspection, leave the factory is permitted

**Remarks:**  
This product is qualified according to the delivery inspection.

**Surveyor:**

Approved by:

Shenzhen Cumark New Technology Co.,Ltd

**matters need attention**

- 一、 The product warranty period is 18 months from the factory product,Or 12 months from the product debugging,To expire first the shall prevail.Customer is a guarantee of products stipulated by the local vendors may be related to the above terms,In its sales and warranty provisions are described in detail.Our company does not assume any liability beyond the warranty terms.
- 二、 The fuselage bar code is the only basis for the judge warranty period.
- 三、 Warranty period,Under the condition of normal use, users according to the manual,Product failure or damage,Division I is responsible for free maintenance.On the transport process,Open the package、 installation、 Commissioning and use of the resulting damage is not responsible for the drive.For collateral damage our company does not undertake any responsibility.
- 四、 Warranty period,By the following causes lead to product failure or damage,Maintenance costs will be charged according to the regulations.
  - 1) Incorrect use、 Improper installation or maintenance of the transformation.
  - 2) earthquake、 thunder and lightning、 Voltage abnormality、 fire、 Floods and other natural disasters or two hypo-disasters.
  - 3) Buy the arrival of the later generations to fall or handling damage.
  - 4) The product itself outside of the disorder,Factors such as external equipment, etc.
  - 5) In excess of specified in the manual product technical indicators or its rated range application under the condition of bad environment,Such as excessive ambient temperature,corrosion、 Dust pollution, etc.
- 五、 Product failure or damage occurs,Would you please fill in the right «product warranty card» items in the content.
- 六、 Service charge is calculated according to the actual cost,If there is a contract,According to the principle of contract priority processing.
- 七、 Please be sure to keep this card,And the warranty is presented to the maintenance unit.
- 八、 If there is any doubt about this agreement,Please contact your dealer first.The company reserves the right of final interpretation of the above terms and conditions.

Shenzhen cumark new technology co.,ltd

Address:Hongfa Industrial Park, Tangtou Community, Shiyan Town, Bao'an District, Shenzhen

Postal code: 518108Service hotline: (+86) 400 619 2001 Tel: 0755-81785111

Fax: 0755-81785108

## ■ More Information

### Product and Service Consulting

Users want to know more information about this product are welcomed to contact with the local representative office, please provide the product model and the serial number of the product to be consulted in the consultation.

### Provide Feedback on this Manual

We would to invite you to give us valuable advice on our manual. Please contact our local representative office or call our customer service line directly.

# CUMARK

Data coding: 36010003  
Chinese version Hardware manual  
Edition: A.04  
Effective date: 2017-04-13

### ShenZhen Cumark New Technology Co.,Ltd

Address: Hongfa Industrial Park, Tangtou Community, Shiyan Town, Bao'an District, Shenzhen

Postal code: 518108

Tel : 0755-81785111

Fax: 0755-81785108

Hotline : (+86)400 619 2001

 [www.famcocorp.com](http://www.famcocorp.com)

 E-mail: [info@famcocorp.com](mailto:info@famcocorp.com)

 @famco\_group

 Tel: ۰۲۱-۴۸۰۰۰۰۴۹

 Fax: ۰۲۱ - ۴۴۹۹۴۶۴۲

تهران، کیلومتر ۲۱ بزرگراه لشگری (جاده مخصوص کرج)

روبروی پالایشگاه نفت پارس، پلاک ۱۲