

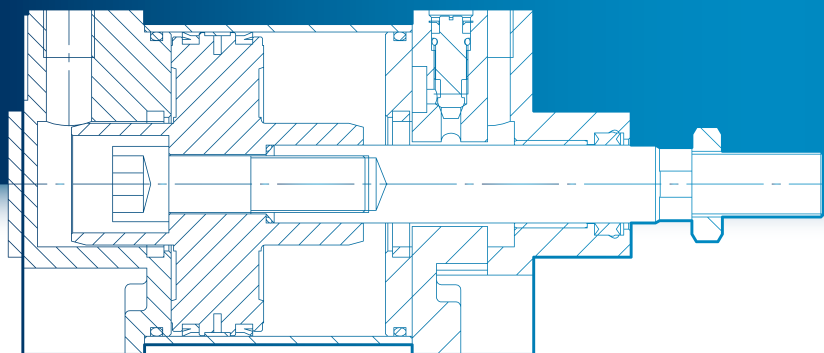

FAMCO
هایپر صنعت

Pneumatic Cylinders

ISO 1552 SERIES (ISO 6431)



aircontrol

www.aircontrol.es

www.famcocorp.com

E-mail: info@famcocorp.com

@famco_group

Tel: ۰۲۱-۴۸۰۰۰۰۴۹

Fax: ۰۲۱-۴۴۹۹۴۶۴۲

تهران، کیلومتر ۲۱ بزرگراه لشگری (جاده مخصوص کرج)

روبروی پالایشگاه نفت پارس، پلاک ۱۲

Lifelong

1962... We have already been manufacturing pneumatic cylinders for half a century now. We can say that this is a lifetime's work. Time flies, as does innovation, and we never tire of manufacturing pneumatic cylinders and continuously improving our products; it's part of us, of our identity, impossible to erase. It's in our history, in our present and our future. We are "the cylinder company".

We could give a boring speech to introduce our "lifelong" product, but we don't want to, nor need to. We all know that pneumatic cylinders exist and we know their basic functions; like all pneumatic cylinder manufacturers, we know how to make them. Some do it better than others, but we all know how to do it. It's like learning to ride a bike... or to swim. You learn it and never forget. Some go to the pool on occasions and dare to take a dip in the sea on their holidays. Others go further, driven by their passion for water... They swim deeper, they last longer under water, swim faster, in different styles and catch the waves that take them further... We are this last type of swimmer.

As we have explained before, the difference between one swimmer and the other lies particularly in their passion. That passion that we also have for the will to supply products of the best quality, for promoting what a "good service" really is... For achieving the recognition of our clients that makes us continue innovating and working with even more passion and motivation. Because it feels good when you are acknowledged for your good work. At the end of the day, it's yours... "lifelong".

AirControl, passion for cylinders...



Index

Profile cylinders

A705 Series

ISO 15552 (ISO 6431) · VDMA 24562
Ø 32 ... 100mm
Double acting



Page
6*

* Fixing elements
Pages 16-23

Tie rod cylinders

A701 Series

ISO 15552 (ISO 6431) · VDMA 24562
Ø 32 ... 320 mm
Double acting

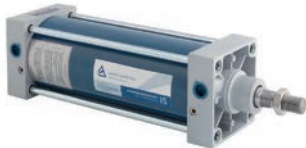

Page
9*

AQ70 Series

All steel

ISO 15552 (ISO 6431) · VDMA 24562
Ø 32 ... 320 mm
Double acting



Page
10*

AT70 Series

Stainless steel

ISO 15552 (ISO 6431) · VDMA 24562
Ø 32 ... 200 mm
Double acting



Page
24

Technical information

Fluid

AirControl cylinders are designed to work with non-lubricated air, which means that the cylinder components are lubricated in order to guarantee a correct operation. If you decide to use lubricated air, it's important that the use is continuous, since this lubrication removes the one applied in the assembly phase.

Parameters

Bore: inside diameter of the cylinder liner (mm)
 Stroke: working travel (mm)
 Working pressure: (bar)
 Working temperature: (°C)
 Travel speed: (m/s)
 Damping force: (Nm)
 Air consumption: (nl/min)
 Theoretical force: (N)

Strokes

All strokes available upon request.

Force calculation

Bore mm	Available area cm ²	Force (N) at pressure (bar)										
		1	2	3	4	5	6	7	8	9	10	
8	Outward stroke	50	4.93	9.86	15	20	25	30	35	39	44	49
	Return stroke	38	3.73	7.46	11	15	19	22	26	30	34	37
10	Outward stroke	79	7.70	15.41	23	31	39	46	54	62	69	77
	Return stroke	66	6.47	12.94	19	26	32	39	45	52	58	65
12	Outward stroke	113	11.09	22.19	33	44	55	67	78	89	100	111
	Return stroke	85	8.32	16.64	25	33	42	50	58	67	75	83
16	Outward stroke	201	20	39	59	79	99	118	138	158	178	197
	Return stroke	173	17	34	51	68	85	102	119	136	153	170
20	Outward stroke	314	31	62	92	123	154	185	216	247	277	308
	Return stroke	264	26	52	78	104	129	155	181	207	233	259
25	Outward stroke	491	48	96	144	193	241	289	337	385	433	482
	Return stroke	412	40	81	121	162	202	243	283	324	364	404
32	Outward stroke	804	79	158	237	316	394	473	552	631	710	789
	Return stroke	691	68	136	203	271	339	407	475	542	610	678
40	Outward stroke	1257	123	247	370	493	616	740	863	986	1109	1233
	Return stroke	1056	104	207	311	414	518	621	725	828	932	1036
50	Outward stroke	1963	193	385	578	770	963	1156	1348	1541	1734	1926
	Return stroke	1649	162	324	485	647	809	971	1133	1294	1456	1618
63	Outward stroke	3117	306	612	917	1223	1529	1835	2141	2446	2752	3058
	Return stroke	2803	275	550	825	1100	1375	1650	1925	2200	2475	2750
80	Outward stroke	5027	493	986	1479	1972	2466	2959	3452	3945	4438	4931
	Return stroke	4536	445	890	1335	1780	2225	2670	3115	3560	4005	4449
100	Outward stroke	7854	770	1541	2311	3082	3852	4626	5393	6164	6934	7705
	Return stroke	7363	722	1445	2167	2889	3612	4334	5056	5779	6501	7223
125	Outward stroke	12272	1204	2408	3612	4815	6019	7223	8427	9631	10835	12039
	Return stroke	11468	1125	2250	3375	4500	5625	6750	7875	9000	10125	11250
160	Outward stroke	20106	1972	3945	5917	7890	9862	11835	13807	15779	17752	19724
	Return stroke	18850	1849	3698	5547	7397	9246	11095	12944	14793	16642	18491
200	Outward stroke	31416	3082	6164	9246	12328	15410	18491	21573	24655	27737	30819
	Return stroke	30159	2959	5917	8876	11835	14793	17752	20710	23669	26628	29586
250	Outward stroke	49087	4815	9631	14446	19262	24077	28893	33708	38524	43339	48155
	Return stroke	47124	4623	9246	13869	18491	23114	27737	32360	36983	41606	46229
320	Outward stroke	80425	7890	15779	23669	31559	39448	47338	55228	63117	71007	78897
	Return stroke	77308	7584	15168	22752	30335	37919	45503	53087	60671	68255	75839

Air consumption calculation

Bore (mm)	Air pressure (bar)									
	1	2	3	4	5	6	7	8	9	10
10	0.002	0.002	0.003	0.004	0.005	0.005	0.006	0.007	0.008	0.008
12	0.002	0.003	0.004	0.006	0.007	0.008	0.009	0.010	0.011	0.0121
16	0.004	0.006	0.008	0.010	0.012	0.014	0.016	0.018	0.020	0.021
20	0.006	0.009	0.012	0.015	0.018	0.021	0.024	0.027	0.031	0.034
25	0.010	0.014	0.019	0.024	0.029	0.033	0.038	0.043	0.048	0.052
32	0.016	0.024	0.031	0.039	0.047	0.055	0.063	0.070	0.078	0.086
40	0.025	0.037	0.049	0.061	0.073	0.086	0.098	0.110	0.122	0.134
50	0.039	0.058	0.077	0.096	0.115	0.134	0.153	0.172	0.191	0.210
63	0.061	0.092	0.122	0.152	0.182	0.212	0.242	0.273	0.303	0.333
80	0.099	0.148	0.196	0.245	0.294	0.342	0.391	0.440	0.488	0.537
100	0.155	0.231	0.307	0.383	0.459	0.535	0.611	0.687	0.763	0.839
125	0.242	0.360	0.479	0.598	0.717	0.836	0.954	1.073	1.192	1.311
160	0.396	0.590	0.785	0.980	1.174	1.369	1.564	1.758	1.953	2.147
200	0.618	0.922	1.227	1.531	1.835	2.139	2.443	2.747	3.051	3.355
250	0.966	1.441	1.916	2.392	2.867	3.342	3.817	4.292	4.768	5.243
320	1.583	2.361	3.140	3.918	4.697	5.476	6.254	7.033	7.811	8.590

Air consumption in outward/return stroke in NI/min by cms. of stroke, according to the pressure (bar) at 20°C.

Load to damp

For a correct operation of the cylinder, it's necessary to damp the mass in motion, in order to reduce its kinetic energy gradually. The highest possible mass to damp varies, depending on the travel speed and the capacity of the shock absorber. The diagram shows these values for the different bore sizes of the cylinder.

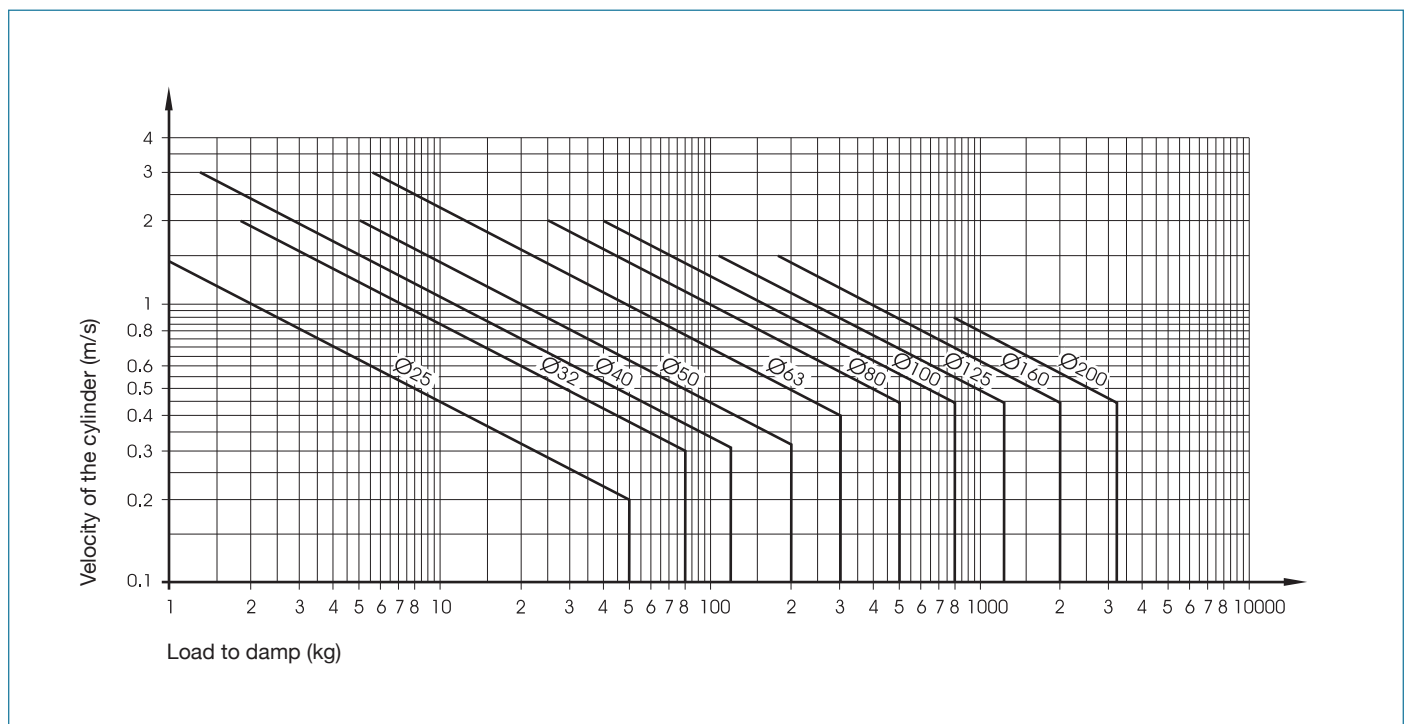

A705 Series

Profile cylinders







► ISO 15552 (ISO 6431) · VDMA 24562

AirControl's ISO 15552 (ISO 6431) cylinders are double effect cylinders manufactured according to European standard ISO 15552 and have bores between 32 and 125 mm. All these cylinders are cushioned and magnetic. It is possible to use a special design, which includes Viton seals for high temperatures.

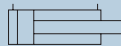

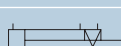
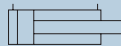
* A * 705 A * * * A * * * * *

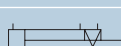
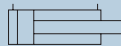
Codification

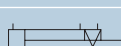
-	No detector	<table border="1"> <thead> <tr> <th colspan="2">Version</th> </tr> </thead> <tbody> <tr> <td>-</td> <td></td> </tr> <tr> <td>4</td> <td></td> </tr> <tr> <td>6</td> <td></td> </tr> </tbody> </table>	Version		-		4		6	
Version										
-										
4										
6										
M1	With one detector									
M2	With two detectors									
	Stroke (mm)									
	Internal bore (mm)									
A	High temperature (HT)									
F	Bellow									
K	Stainless steel piston rod									
L	Stainless steel piston rod + HT seals									
4	Through rod									
6	Rod lock (contact our technical department for dimensions)									

For other versions, please contact our technical department.

Strokes

All strokes available according to the customer's needs.

Technical specifications

Fluid	Lubricated or non lubricated air
Operating temperature range	-20°C → +80°C (-20°C → +150°C with Viton seals)
Maximum operating pressure	10 bar
Forces	Page 4
Air consumption	Page 5

A705 Series
Profile cylinders

ISO 15552 (ISO 6431) · VDMA 24562 ◀

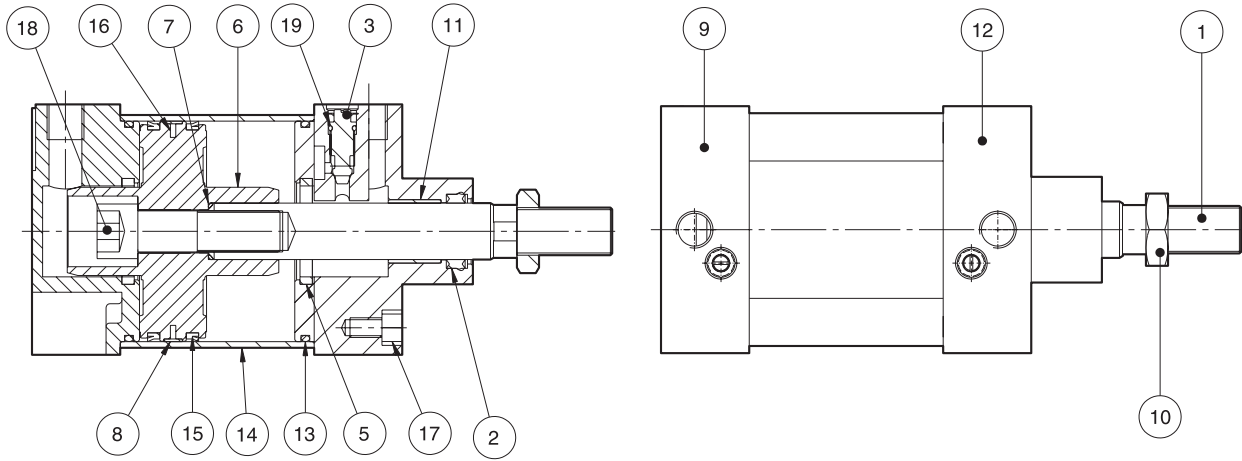

Pos.	Description	Pcs	Material
1	Piston rod	1	Chrome-plated C45 steel
*2	Scraper ring	1	NBR
3	Cushion screw	2	Nickel-plated copper
*5	Cushioning seal	2	NBR
6	Piston	1	Aluminium
*7	O-Ring	1	NBR
*8	Slipping segment	1	Graphite Teflon
9	Rear cover	1	Aluminium die-casting
10	Locknut	1	Zinc-plated steel
11	Guide bush	1	PTFE Ø32-63 Bronze Ø80-125
12	Front cover	1	Aluminium die-casting
*13	O-Ring	2	NBR
14	Cylinder barrel	1	Anodized aluminium
*15	Collar	2	NBR
16	Magnetic ring	1	Plastoferrite
17	End cover screw	8	Zinc-plated steel
18	Piston rod nut	1	Zinc-plated steel
*19	O-Ring	2	NBR

* Spare part kit

Spare part kit	Bore					
	32	40	50	63	80	100
Standard	701KR032	701KR040	701KR050	701KR063	701KR080	701KR100
High temperature	A701KR032	A701KR040	A701KR050	A701KR063	A701KR080	A701KR100

A705 Series Profile cylinders

► ISO 15552 (ISO 6431) · VDMA 24562

Double acting

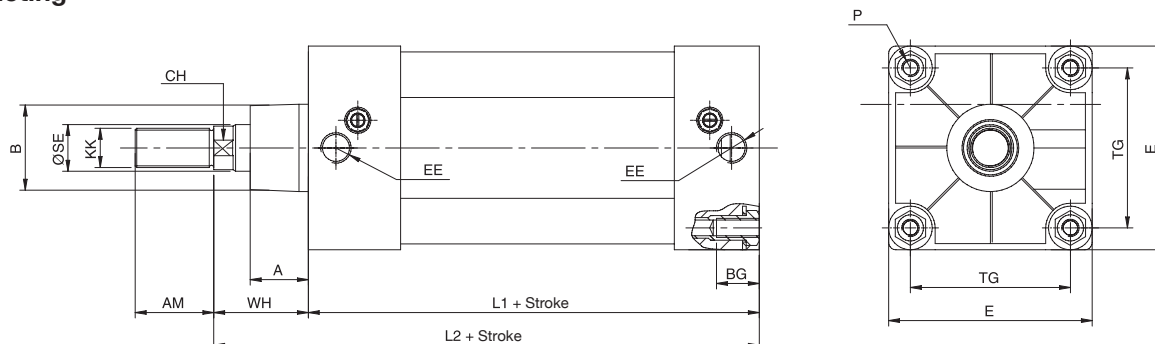

Ø	A	AM(2)	B ^{e11}	E	EE	KK	L1	L2	P	SEØ	TG	WH	CH	BG
32	20	22	30	47	G1/8"	M10x1.25	94 ±0.4	120	M6	12	32.5	26	10	16
40	22	24	35	53	G1/4"	M12x1.25	105 ±0.7	135	M6	16	38	30	13	16
50	28	32	40	65	G1/4"	M16x1.5	106 ±0.7	143	M8	20	46.5	37	16	16
63	28	32	45	75	G3/8"	M16x1.5	121 ±0.8	158	M8	20	56.5	37	16	16
80	34	40	45	95	G3/8"	M20x1.5	128 ±0.8	174	M10	25	72	46	21	16
100	38	40	55	115	G1/2"	M20x1.5	138 ±1	189	M10	25	89	51	21	16

Through rod

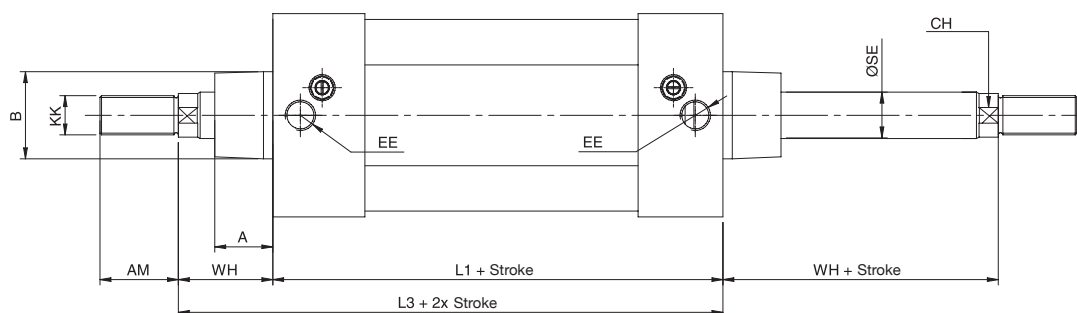

Ø	A	AM(2)	B ^{e11}	EE	KK	L1	L3	SEØ	WH	CH
32	20	22	30	G1/8"	M10x1.25	94 ± 0.4	146 ± 0.4	12	26	10
40	22	24	35	G1/4"	M12x1.25	105 ± 0.7	165 ± 0.7	16	30	13
50	28	32	40	G1/4"	M16x1.5	106 ± 0.7	180 ± 0.7	20	37	16
63	28	32	45	G3/8"	M16x1.5	121 ± 0.8	195 ± 0.8	20	37	16
80	34	40	45	G3/8"	M20x1.5	128 ± 0.8	220 ± 0.8	25	46	21
100	38	40	55	G1/2"	M20x1.5	138 ± 1	240 ± 1	25	51	21

With bellows

See page 13

A701 Series

Tie rod cylinders

► ISO 15552 (ISO 6431) · VDMA 24562

A701 Series are double acting cylinders, manufactured according to ISO 15552 (ISO 6431) Standards. They are available in bores from 32 to 320 mm. All these cylinders are magnetic as standard in all possible strokes.

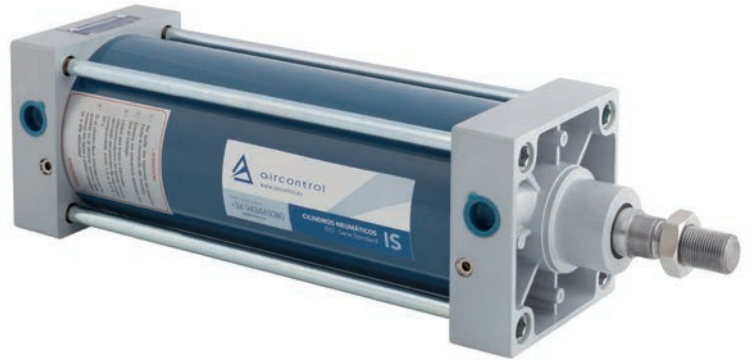

★ A ★ 701 A ★ ★ ★ A ★ ★ ★ ★ ★ ★

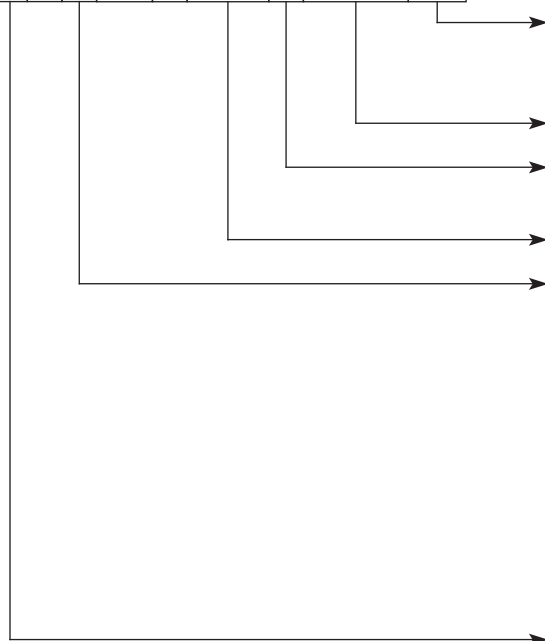

Codification

-	No detector	Version	-	
M1	With one detector		4	
M2	With two detectors			
Stroke (mm)				
A	Cushioned			
N	Non cushioned			
Internal bore (mm)				
A	High temperature (HT)			
B	Bellows + HT seals			
C	Chrome-plated steel tube			
D	Chrome-plated steel tube + HT seals			
F	Bellows			
H	Chrome-plated steel tube + Bellows			
K	Stainless steel piston rod			
L	Stainless steel piston rod + HT seals			
M	Stainless steel piston rod + HT seals + Chrome-plated steel tube			
N	Stainless steel piston rod + Chrome-plated steel tube			
P	Steel tube			
U	Steel tube + HT seals			
4	Through rod			
6	Rod lock up to Ø125 mm (contact our technical department for dimensions)			

For other versions, please contact our technical department.

Strokes

All strokes available according to the customer's needs.

Technical specifications

Cylinder covers	Aluminium alloy
Piston rod	Chrome-plated steel (stainless steel on request)
Tie rods	Zinc-plated steel
Tube	Anodized aluminium
Seals	NBR
Cushioning	Micrometric control
Environmental temperature range	-10°C → +80°C
Fluid temperature range	0°C → +40°C (-20°C → +150°C with Viton seals)
Lubrication	Not required
Fluid	Filtered air
Maximum operating pressure	10 bar
Forces	Page 4
Air consumption	Page 5

AQ70 Series

Tie rod cylinders. All steel.

► ISO 15552 (ISO 6431) · VDMA 24562

AQ70 Series are double acting cylinders, manufactured according to ISO 15552 (ISO 6431) Standards. They are available in bores from 32 to 320 mm. Covers, tube, piston, piston rod and tie rods are made in steel.



★ A Q 70 A ★★ ★ A ★★ ★ ★

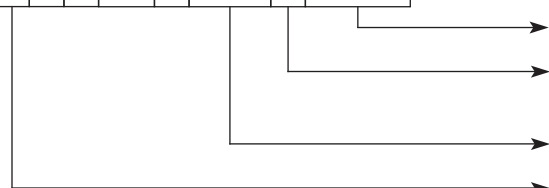

Codification

Stroke (mm)	Version
A Cushioned	-
N Non cushioned	
Internal bore (mm)	
4 Through rod	4
6 Rod lock up to Ø125 mm (contact our technical department for dimensions)	

For other versions (piston rod in stainless steel, high temperature seals, chromed plated steel tube, bellow...), please, contact our technical departmente.

Strokes

All strokes available according to the customer's needs.

Technical specifications

Covers	Steel
Piston rod	Chromed plated steel (stainless steel is possible)
Tie rods	Zinc-plated steel
Tube	Steel
Seals	NBR
Cushioning	Micrometric control
Environment temperatura range	-10°C → +80°C
Fluid temperatura range	0°C → +40°C (-30°C → +200°C with Viton seals)
Lubrication	Not required
Fluid	Filtered air
Máximum operating pressure	10 bar
Forces	Page 4
Air consumption	Page 5

A701 and AQ70 Series Tie rod cylinders

► ISO 15552 (ISO 6431) · VDMA 24562

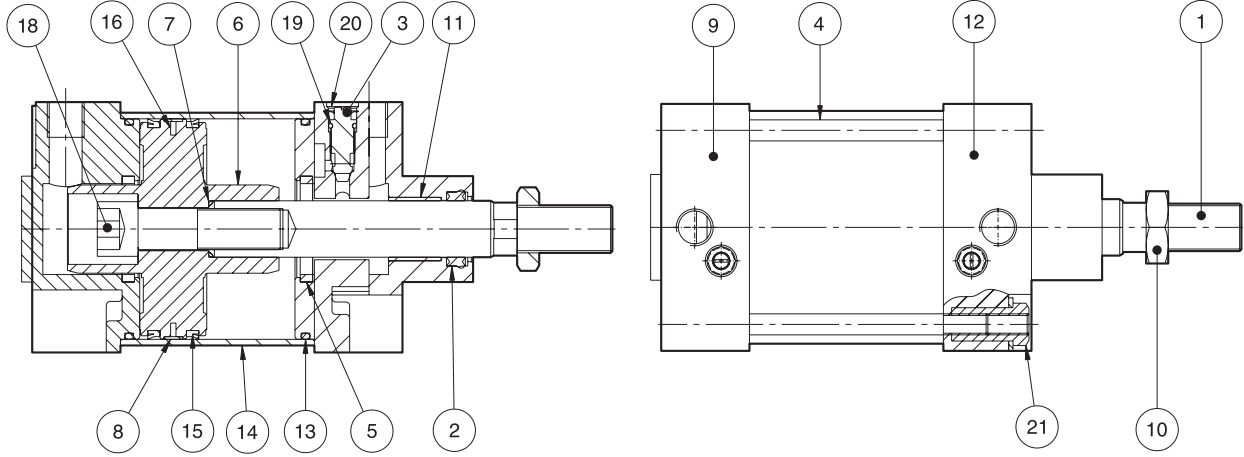

Pos.	Description	A701 Series		AQ70 Series	
		Pcs	Material	Pcs	Material
1	Piston rod	1	Chrome-plated C45 steel	1	Chrome-plated C45 steel
*2	Scraper ring	1	NBR	1	NBR
3	Regulator	2	Nickel plated brass	2	Nickel plated brass
4	Tie rod	4	Zinc plated steel	4	Zinc plated steel
*5	Cushioning seal	2	NBR	2	NBR
6	Piston	1	Aluminium	1	Steel
*7	O-Ring	1	NBR	1	NBR
*8	Slipping segment	1	PTFE 561	1	PTFE 561
9	Rear cover	1	Aluminium	1	Steel
10	Locknut	1	Zinc plated steel	1	Zinc plated steel
11	Guide bush	1	PTFE Ø32-63 Bronze Ø80-320	1	PTFE Ø32-63 Bronze Ø80-320
12	Front cover	1	Aluminium	1	Steel
*13	O-Ring	2	NBR	2	NBR
14	Cylinder barrel	1	Anodized aluminium	1	Steel
*15	Collar	2	NBR	2	NBR
16	Magnetic ring	1	Plastoferrite	-	-
18	Piston rod screw	1	Steel	1	Steel
*19	O-Ring	2	NBR	2	NBR
20	Lock washer	2	Plastic	2	Steel
21	Tie rod nut	8	Zinc plated steel	8	Zinc plated steel

* Spare part kit

Spare part kit A701 Series	Bore										
	32	40	50	63	80	100	125	160	200	250	320
Standard	701KR032	701KR040	701KR050	701KR063	701KR080	701KR100	701KR125	701KR160	701KR200	701KR250	701KR320
High temperature	A701KR032	A701KR040	A701KR050	A701KR063	A701KR080	A701KR100	A701KR125	A701KR160	A701KR200	A701KR250	A701KR320

Spare part kit AQ70 Series	Bore										
	32	40	50	63	80	100	125	160	200	250	320
Standard	70KR032	70KR040	70KR050	70KR063	70KR080	70KR100	70KR125	70KR160	70KR200	70KR250	70KR320
High temperature	A70KR032	A70KR040	A70KR050	A70KR063	A70KR080	A70KR100	A70KR125	A70KR160	A70KR200	A70KR250	A70KR320

A701 and AQ70 Series

Tie rod cylinders

► ISO 15552 (ISO 6431) · VDMA 24562

Double acting

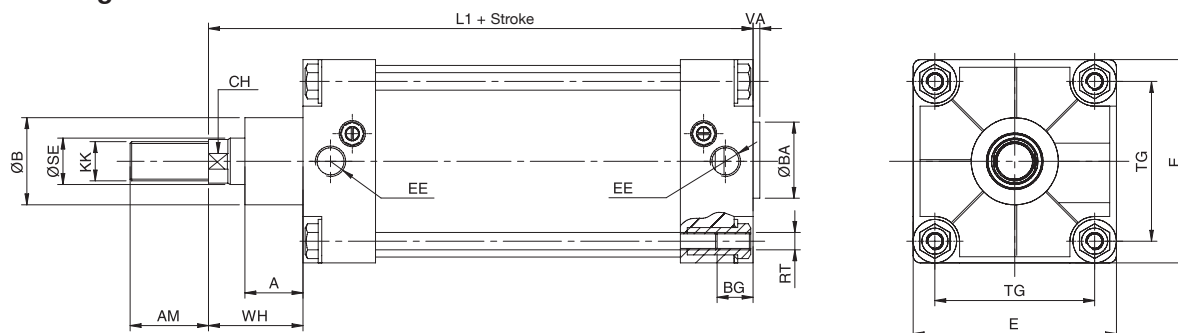

Ø	A	AM($_{-2}^0$)	B ^{e11}	E	EE	KK	L1	SE	TG	WH	CH	RT	BG	VA*	BA*
32	15	22	30	47	G1/8"	M10x1,25	120 ^{+0.4}	12	32,5	26	10	M6	16		
40	18	24	35	53	G1/4"	M12x1,25	135 ^{+0.7}	16	38	30	13	M6	16		
50	25	32	40	65	G1/4"	M16x1,5	143 ^{+0.7}	20	46,5	37	16	M8	16		
63	24	32	40	75	G3/8"	M16x1,5	158 ^{+0.8}	20	56,5	37	16	M8	16		
80	30	40	45	95	G3/8"	M20x1,5	174 ^{+0.8}	25	72	46	21	M10	16		
100	32	40	45	115	G1/2"	M20x1,5	189 ⁺¹	25	89	51	21	M10	16		
125	45	54	60	140	G1/2"	M27x2	225 ⁺¹	32	110	65	28	M12	20	6	60
160	60	72	60	180	G3/4"	M36x2	260 ^{+1.7}	40	140	80	34	M16	21	6	65
200	70	72	67	220	G3/4"	M36x2	275 ^{+1.7}	40	175	95	34	M16	22	6	75
250	70	84	90	275	G1"	M42x2	305 ⁺²	50	220	105	46	M20	25	9	90
320	83	96	110	344	G1"	M48x2	340 ⁺²	63	270	120	55	M24	28	9	110

*Dimensions only for A701 Series

Through rod

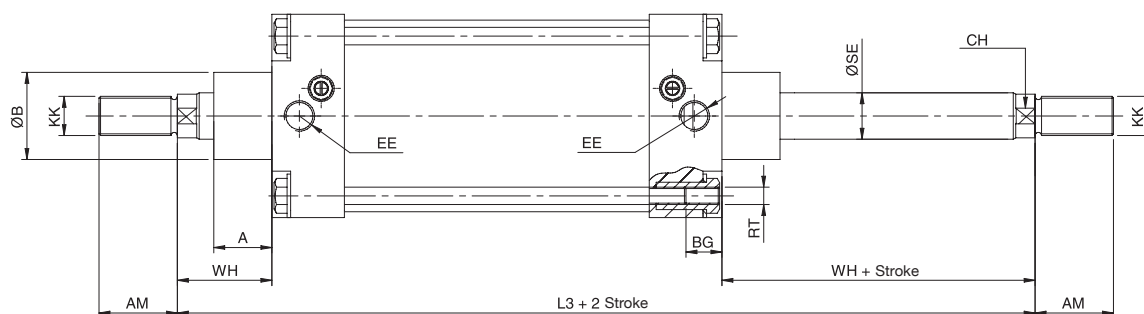

Ø	A	AM($_{-2}^0$)	B ^{e11}	EE	KK	L3	SEØ	WH	CH	RT	BG
32	20	22	30	G1/8"	M10x1,25	146 ^{+0.4}	12	26	10	M6	16
40	22	24	35	G1/4"	M12x1,25	165 ^{+0.7}	16	30	13	M6	16
50	28	32	40	G1/4"	M16x1,5	180 ^{+0.7}	20	37	16	M8	16
63	28	32	40	G3/8"	M16x1,5	195 ^{+0.8}	20	37	16	M8	16
80	34	40	45	G3/8"	M20x1,5	220 ^{+0.8}	25	46	21	M10	16
100	38	40	45	G1/2"	M20x1,5	240 ⁺¹	25	51	21	M10	16
125	40	54	60	G1/2"	M27x2	290 ⁺¹	32	65	28	M12	20
160	45	72	60	G3/4"	M36x2	340 ^{+1.7}	40	80	34	M16	21
200	47	72	67	G3/4"	M36x2	370 ^{+1.7}	40	95	34	M16	22
250	63	84	90	G1"	M42x2	410 ⁺²	50	105	46	M20	25
320	63	96	110	G1"	M48x2	460 ⁺²	63	120	55	M24	28

A701 y AQ70 Series
Tie rod cylinders
ISO 15552 (ISO 6431) · VDMA 24562 ◀

With bellows

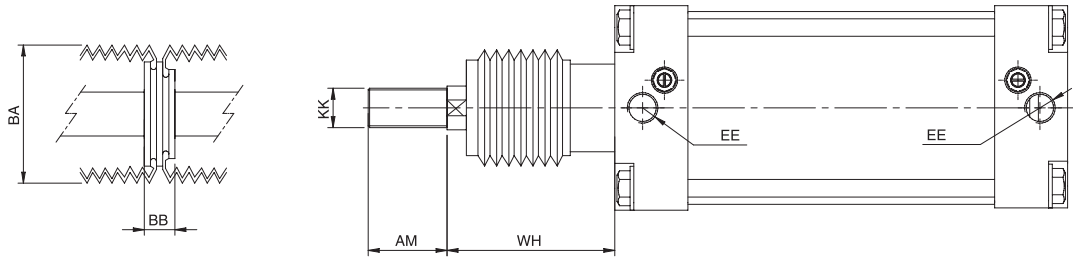

Ø	Piston rod	BA	BB	AM	EE	KK	WH	Each additional bellows	Max. Stroke per bellows	Bellow ref.	Front bellow ref.	Connecting piece ref.	Front cap ref.
32	12	48	15	22	G1/8"	M10x1,25	106	90	200	26 04 52	701FY03A	701FZ03A	701FX03A
40	16	48	15	24	G1/4"	M12x1,25	110	90	200	26 04 52	701FY04A	701FZ04A	701FX04A
50	20	48	15	32	G1/4"	M16x1,5	117	90	200	26 04 52	701FY05A	701FZ05A	701FX05A
63	20	48	15	32	G3/8"	M16x1,5	120	90	200	26 04 52	701FY05A	701FZ05A	701FX05A
80	25	48	15	40	G3/8"	M20x1,5	126	90	200	26 10 52	701FY08A	701FZ08A	701FX08A
100	25	85	20	40	G1/2"	M20x1,5	127	90	300	26 10 52	701FY08A	701FZ08A	701FX08A
125	32	85	20	54	G1/2"	M27x2	130	90	300	26 10 52	701FY12A	701FZ12A	701FX12A
160	40	85	20	72	G3/4"	M36x2	146	90	300	26 10 52	701FY16A	701FY16A	701FX16A
200	40	85	20	72	G3/4"	M36x2	150	90	300	26 10 52	701FY16A	701FY16A	701FX20A

ISO 15552 Cylinders

Magnetic switches for A705 Series and A701 Series up to Ø 200 mm

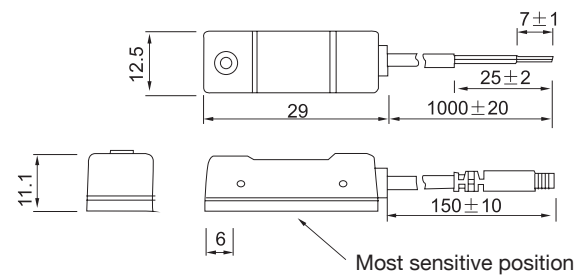
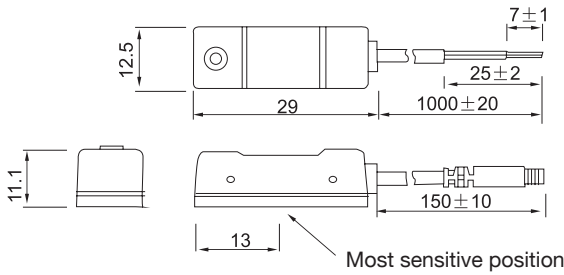

Type	300DSM21R	300DSM21N	300DSM21P
Connect diagram			
Parameter			
Wiring method	2 Wire Type		3 Wire Type
Sensor type	Reed	NPN input	PNP output
Operating voltage	5-240V DC/AC		5-30V DC
Max. switching current	100mA max.		20mA max.
Contact rating	10W max.		6W max.
Indicator	Red LED	Red LED	Green LED
Max. exchange frequency	200 Hz		1000 Hz
Temperature range	10~70°C		10~70°C
Enclosure classification	IEC 529 IP67 (NEMA 6)		IEC 529 IP67 (NEMA 6)
Protection circuit	No		With protection
Cable	Ø4.0,2C PVC		Ø4.0,2C PVC
Cable length: 1m	Gray color, oil resistance PVC		Black color, oil resistance PVC

Magnetic switches for A701 Series Ø 250 mm y Ø 320 mm

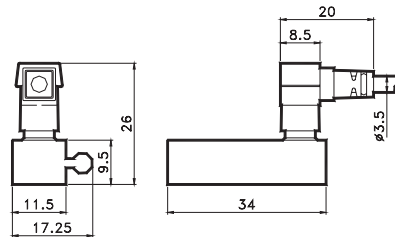

DSM2C525 - 2 Wires

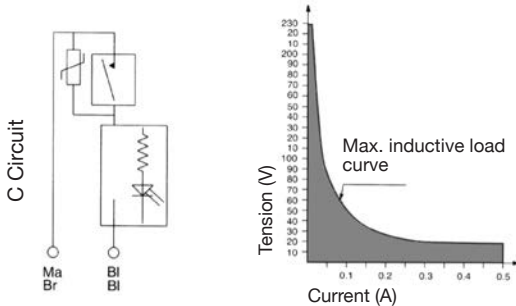

DSM3N225 - 3 Wires

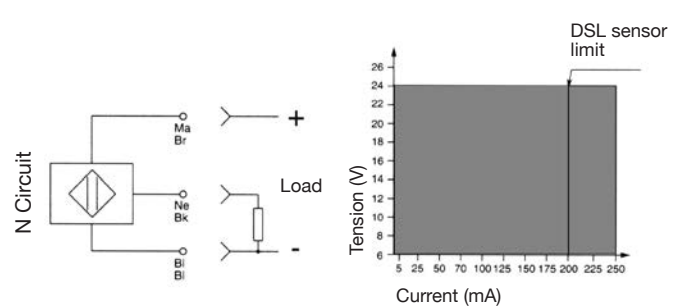

Code	Voltage range	Switching current	Switching capacity	Protection degree	Working temperature	ON time	OFF time	Electric life	Contact resistance	Contact function
	V	A	VA/W		°C	ms/µs	ms/µs	impulses	Ω	
DSM2C525	3-230 AC-DC	0.5	10 VA	IP67	-20 / +85	0.5 ms	0.01 ms	10 ⁷	0.1	
DSM3N225	6-30 DC	0.25	6 W	IP67	-20 / +85	0.8 µs	0.3 µs	10 ⁹	-	

ISO 15552 Cylinders Brackets for magnetic switches

A705 Series / Profile cylinders

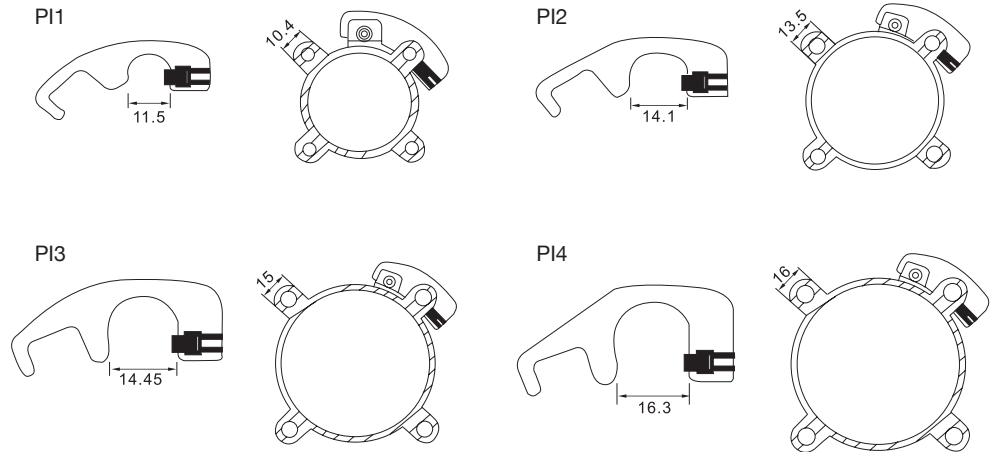

A701 Series / Tie rod tube up to Ø 200 mm

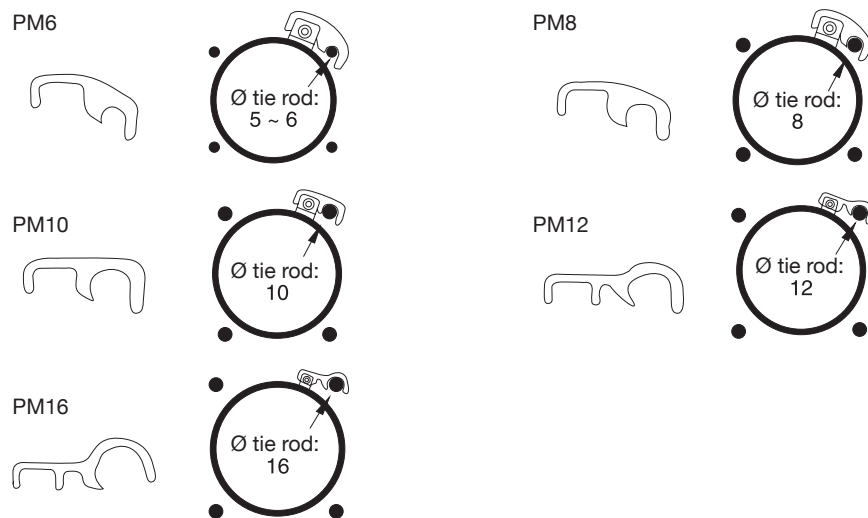

A701 Series / Tie rod tube Ø 250 mm y Ø 320 mm

DST82 (Ø 250 mm)

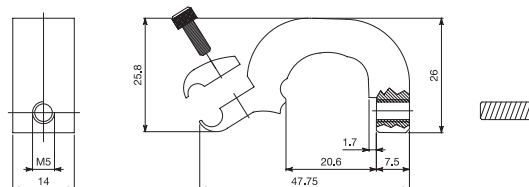

DST52 (Ø 320 mm)

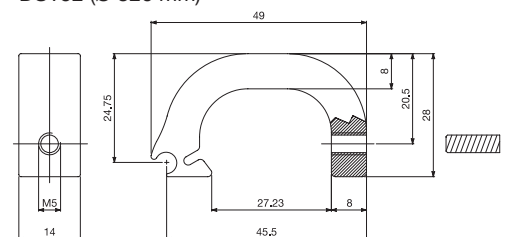

ISO 1552 Cylinders

Cylinder mountings

Foot bracket - AB

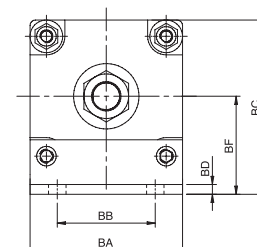
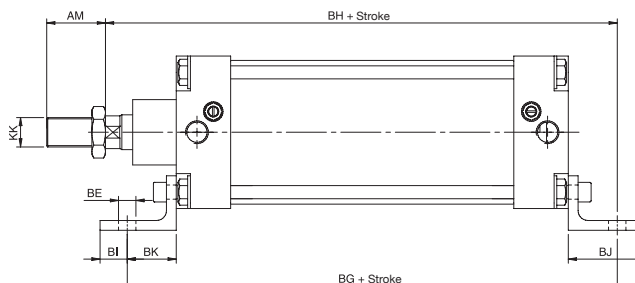
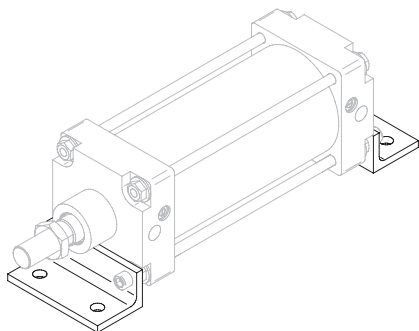

Ø	BA	BB	BC	BD	BE	BF	BG	BH	BI	BJ	BK	AM	KK	COD.	Ø
32	45	32 ^{±0,3}	55,5	5	7 ^{H14}	32 ^{JS15}	142 ^{±1,25}	144 ^{±1,25}	11	35	24	22 ^{0/-2}	M10X1,25	G70AB032	32
40	52	36 ^{±0,3}	63	5	9 ^{H14}	36 ^{JS15}	161 ^{±1,25}	163 ^{±1,25}	15	43	28	24 ^{0/-2}	M12X1,25	G70AB040	40
50	65	45 ^{±0,3}	78,25	6	9 ^{H14}	45 ^{JS15}	170 ^{±1,25}	175 ^{±1,25}	15	47	32	32 ^{0/-2}	M16X1,5	G70AB050	50
63	75	50 ^{±0,3}	88,25	6	9 ^{H14}	50 ^{JS15}	185 ^{±1,6}	190 ^{±1,6}	15	47	32	32 ^{0/-2}	M16X1,5	G70AB063	63
80	95	63 ^{±0,3}	110,5	7	12 ^{H14}	63 ^{JS15}	210 ^{±1,6}	215 ^{±1,6}	20	61	41	40 ^{0/-2}	M20X1,5	G70AB080	80
100	115	75 ^{±0,3}	128,5	7	14 ^{H14}	71 ^{JS15}	220 ^{±1,6}	230 ^{±1,6}	25	66	41	40 ^{0/-2}	M20X1,5	G70AB100	100
125	140	90 ^{±0,4}	160	9	16 ^{H14}	90 ^{JS15}	250 ^{±2}	270 ^{±2}	25	60	45	54 ^{0/-2}	M27X2	G70AB125	125
160	180	115 ^{±0,4}	205	10	18 ^{H14}	115 ^{JS15}	300 ^{±2}	323 ^{±2}	20	80	60	72 ^{0/-2}	M36X2	G70AB160	160
200	220	135 ^{±0,5}	245	10	22 ^{H14}	135 ^{JS15}	320 ^{±2}	345 ^{±2}	30	100	70	72 ^{0/-2}	M36X2	G70AB200	200
250	275	165 ^{±1}	302,5	20	28 ^{H14}	165 ^{JS15}	350 ^{±2}	380 ^{±2}	40	115	75	84 ^{0/-2}	M42X2	G70AB250	250
320	353	200 ^{±1}	372,5	23	35 ^{H14}	200 ^{JS15}	390 ^{±2,5}	425 ^{±2,5}	45	130	85	96 ^{0/-2}	M48X2	G70AB320	320

Flange - AA

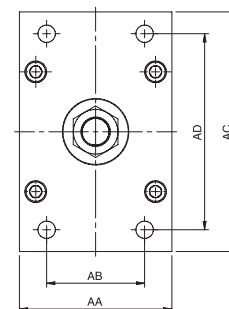
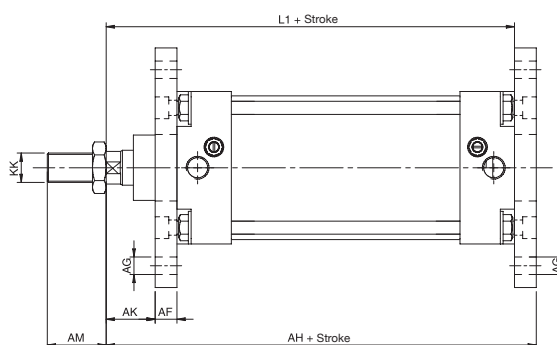
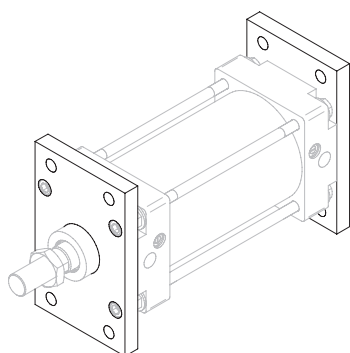

Ø	AA	AB	AC	AD	AF	AG	AH	L1	AK	AM	KK	COD.	Ø
32	46	32 ^{JS14}	80	64 ^{JS14}	10	7	130 ^{±1,25}	120	16 ^{±1,6}	22 ^{0/-2}	M10X1,25	G70AA032	32
40	55	36 ^{JS14}	91	72 ^{JS14}	10	9	145 ^{±1,25}	135	20 ^{±1,6}	24 ^{0/-2}	M12X1,25	G70AA040	40
50	62	45 ^{JS14}	107	90 ^{JS14}	12	9	155 ^{±1,25}	143	24,5 ^{±1,6}	32 ^{0/-2}	M16X1,5	G70AA050	50
63	80	50 ^{JS14}	120	100 ^{JS14}	12	9	170 ^{±1,6}	158	24,5 ^{±2}	32 ^{0/-2}	M16X1,5	G70AA063	63
80	95	63 ^{JS14}	155	126 ^{JS14}	16	12	190 ^{±1,6}	174	30 ^{±2}	40 ^{0/-2}	M20X1,5	G70AA080	80
100	114	75 ^{JS14}	180	150 ^{JS14}	16	14	205 ^{±1,6}	189	35 ^{±2}	40 ^{0/-2}	M20X1,5	G70AA100	100
125	140	90 ^{JS14}	220	180 ^{JS14}	20	16	245 ^{±2}	225	45 ^{±2,5}	54 ^{0/-2}	M27X2	G70AA125	125
160	180	115 ^{JS14}	280	230 ^{JS14}	20	18	280 ^{±2}	260	60 ^{±2,5}	72 ^{0/-2}	M36X2	G70AA160	160
200	220	135 ^{JS14}	320	270 ^{JS14}	25	22	300 ^{±2}	275	70 ^{±2,5}	72 ^{0/-2}	M36X2	G70AA200	200
250	280	165 ^{JS14}	395	330 ^{JS14}	25	26	330 ^{±2}	305	80 ^{±2,5}	84 ^{0/-2}	M42X2	G70AA250	250
320	345	200 ^{JS14}	475	400 ^{JS14}	30	33	370 ^{±2,5}	340	90 ^{±2,5}	96 ^{0/-2}	M48X2	G70AA320	320

Max. 1 flange per cylinder. Customer will indicate front or rear position.

ISO 1552 Cylinders Cylinder mountings

Clevis bracket - AC

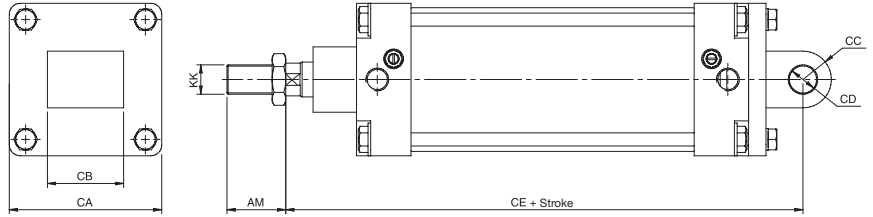
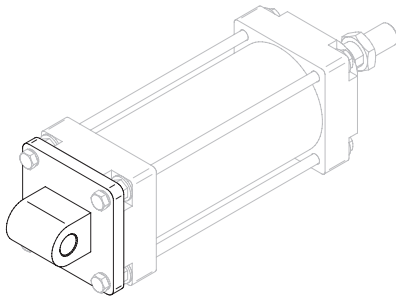

Ø	CA	CB	CC	CD	CE	AM	KK	COD.	Ø
32	47	26 ^{-0,2/-0,6}	11	10 ^{H9}	142 ^{±1,25}	22 ^{0/-2}	M10X1,25	G70AC032	32
40	53	28 ^{-0,2/-0,6}	13	12 ^{H9}	160 ^{±1,25}	24 ^{0/-2}	M12X1,25	G70AC040	40
50	65	32 ^{-0,2/-0,6}	13	12 ^{H9}	170 ^{±1,25}	32 ^{0/-2}	M16X1,5	G70AC050	50
63	75	40 ^{-0,2/-0,6}	17	16 ^{H9}	190 ^{±1,6}	32 ^{0/-2}	M16X1,5	G70AC063	63
80	95	50 ^{-0,2/-0,6}	17	16 ^{H9}	210 ^{±1,6}	40 ^{0/-2}	M20X1,5	G70AC080	80
100	115	60 ^{-0,2/-0,6}	21	20 ^{H9}	230 ^{±1,6}	40 ^{0/-2}	M20X1,5	G70AC100	100
125	140	70 ^{-0,5/-1,2}	26	25 ^{H9}	275 ^{±2}	54 ^{0/-2}	M27X2	G70AC125	125
160	180	90 ^{-0,5/-1,2}	31	30 ^{H9}	315 ^{±2}	72 ^{0/-2}	M36X2	G70AC160	160
200	220	90 ^{-0,5/-1,2}	31	30 ^{H9}	335 ^{±2}	72 ^{0/-2}	M36X2	G70AC200	200
250	275	110 ^{-0,5/-1,2}	41	40 ^{H9}	375 ^{±2}	84 ^{0/-2}	M42X2	G70AC250	250
320	344	120 ^{-0,5/-1,2}	46	45 ^{H9}	420 ^{±2,5}	96 ^{0/-2}	M48X2	G70AC320	320

Clevis bracket - AD

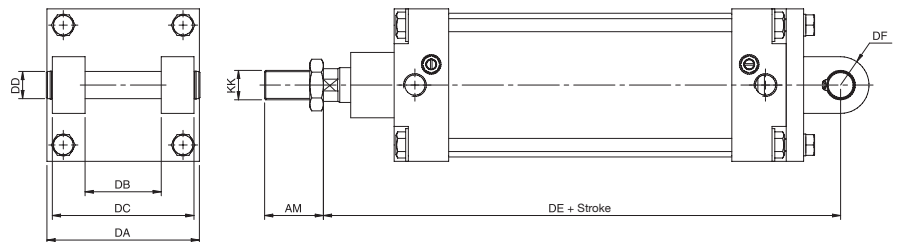
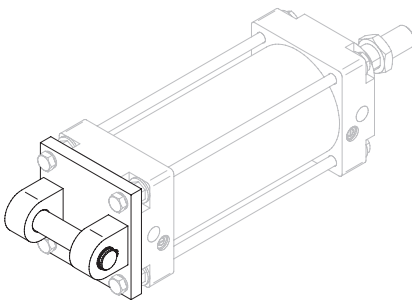

Ø	DA	DB	DC	DD	DE	DF	AM	KK	COD.	Ø
32	47	26 ^{H14}	45 ^{H14}	10 ^{H9}	142 ^{±1,25}	11	22 ^{0/-2}	M10X1,25	G70AD032	32
40	53	28 ^{H14}	52 ^{H14}	12 ^{H9}	160 ^{±1,25}	13	24 ^{0/-2}	M12X1,25	G70AD040	40
50	65	32 ^{H14}	60 ^{H14}	12 ^{H9}	170 ^{±1,25}	13	32 ^{0/-2}	M16X1,5	G70AD050	50
63	75	40 ^{H14}	70 ^{H14}	16 ^{H9}	190 ^{±1,6}	17	32 ^{0/-2}	M16X1,5	G70AD063	63
80	95	50 ^{H14}	90 ^{H14}	16 ^{H9}	210 ^{±1,6}	17	40 ^{0/-2}	M20X1,5	G70AD080	80
100	115	60 ^{H14}	110 ^{H14}	20 ^{H9}	230 ^{±1,6}	21	40 ^{0/-2}	M20X1,5	G70AD100	100
125	140	70 ^{H14}	130 ^{H14}	25 ^{H9}	275 ^{±2}	26	54 ^{0/-2}	M27X2	G70AD125	125
160	180	90 ^{H14}	170 ^{H14}	30 ^{H9}	315 ^{±2}	31	72 ^{0/-2}	M36X2	G70AD160	160
200	220	90 ^{H14}	170 ^{H14}	30 ^{H9}	335 ^{±2}	31	72 ^{0/-2}	M36X2	G70AD200	200
250	275	110 ^{H14}	200 ^{H14}	40 ^{H9}	375 ^{±2}	40	84 ^{0/-2}	M42X2	G70AD250	250
320	345	120 ^{H14}	220 ^{H14}	45 ^{H9}	420 ^{±2,5}	46	96 ^{0/-2}	M48X2	G70AD320	320

ISO 1552 Cylinders

Cylinder mountings

Pivot bracket - AN

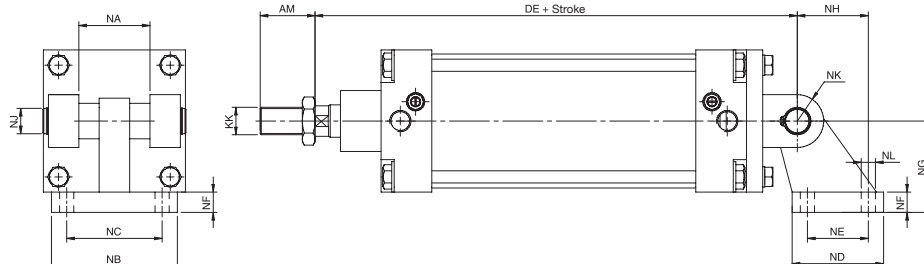
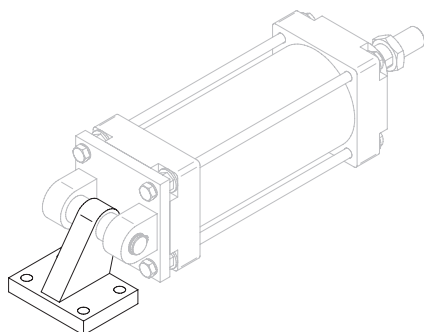

Ø	NA	NB	NC	ND	NE	NF	NG	NH	NJ	NK	NL	DE	AM	KK	COD.	Ø
32	26 ^{-0.2/-0.6}	51	38 ^{JS14}	31	18 ^{JS14}	8	32 ^{JS15}	21 ^{JS14}	10 ^{H9}	10	6,6 ^{H13}	142 ^{±1.25}	22 ^{0/-2}	M10X1,25	B70AN032	32
40	28 ^{-0.2/-0.6}	54	41 ^{JS14}	35	22 ^{JS14}	10	36 ^{JS15}	24 ^{JS14}	12 ^{H9}	11	6,6 ^{H13}	160 ^{±1.25}	24 ^{0/-2}	M12X1,25	B70AN040	40
50	32 ^{-0.2/-0.6}	65	50 ^{JS14}	45	30 ^{JS14}	12	45 ^{JS15}	33 ^{JS14}	12 ^{H9}	13	9 ^{H13}	170 ^{±1.25}	32 ^{0/-2}	M16X1,5	B70AN050	50
63	40 ^{-0.2/-0.6}	67	52 ^{JS14}	50	35 ^{JS14}	12	50 ^{JS15}	37 ^{JS14}	16 ^{H9}	15	9 ^{H13}	190 ^{±1.6}	32 ^{0/-2}	M16X1,5	B70AN063	63
80	50 ^{-0.2/-0.6}	86	66 ^{JS14}	60	40 ^{JS14}	14	63 ^{JS15}	47 ^{JS14}	16 ^{H9}	15	11 ^{H13}	210 ^{±1.6}	40 ^{0/-2}	M20X1,5	B70AN080	80
100	60 ^{-0.2/-0.6}	96	76 ^{JS14}	70	50 ^{JS14}	15	71 ^{JS15}	55 ^{JS14}	20 ^{H9}	19	11 ^{H13}	230 ^{±1.6}	40 ^{0/-2}	M20X1,5	B70AN100	100
125	70 ^{-0.5/-1.5}	124	94 ^{JS14}	90	60 ^{JS14}	20	90 ^{JS15}	70 ^{JS14}	25 ^{H9}	22,5	14 ^{H13}	275 ^{±2}	54 ^{0/-2}	M27X2	B70AN125	125
160	90 ^{-0.5/-1.5}	156	118 ^{JS14}	126	88 ^{JS14}	25	115 ^{JS15}	97 ^{JS14}	30 ^{H9}	31,5	14 ^{H13}	315 ^{±2}	72 ^{0/-2}	M36X2	B70AN160	160
200	90 ^{-0.5/-1.5}	162	122 ^{JS14}	130	90 ^{JS14}	30	135 ^{JS15}	105 ^{JS14}	30 ^{H9}	31,5	18 ^{H13}	335 ^{±2}	72 ^{0/-2}	M36X2	B70AN200	200
250	110 ^{-0.5/-1.5}	200	150 ^{JS14}	160	110 ^{JS14}	35	165 ^{JS15}	128 ^{JS14}	40 ^{H9}	40	22 ^{H13}	375 ^{±2}	84 ^{0/-2}	M42X2	B70AN250	250
320	120 ^{-0.5/-1.5}	234	170 ^{JS14}	186	122 ^{JS14}	40	200 ^{JS15}	150 ^{JS14}	45 ^{H9}	45	26 ^{H13}	420 ^{±2.5}	96 ^{0/-2}	M48X2	B70AN320	320

Intermediate trunnion - AE

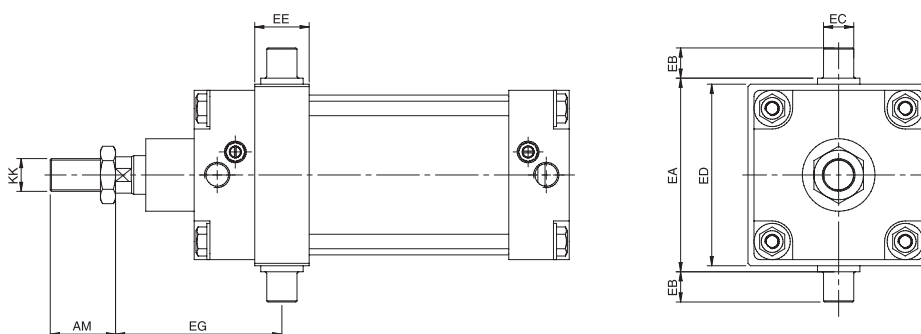
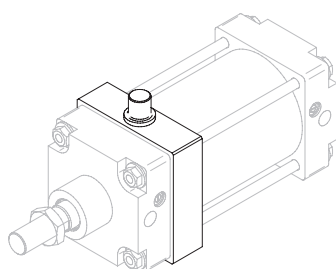

Ø	EA	EB	EC	ED	EE	EG*	AM	KK	COD.	Ø
32	50 ^{h14}	12 ^{h14}	12 ^{e9}	43	20	62 ^{±2}	22 ^{0/-2}	M10x1.25	B70AE032	32
40	63 ^{h14}	16 ^{h14}	16 ^{e9}	56	25	72 ^{±2}	24 ^{0/-2}	M12x1.25	B70AE040	40
50	75 ^{h14}	16 ^{h14}	16 ^{e9}	68	25	79,5 ^{±2}	32 ^{0/-2}	M16x1.5	B70AE050	50
63	90 ^{h14}	20 ^{h14}	20 ^{e9}	82	35	90 ^{±2}	32 ^{0/-2}	M16x1.5	B70AE063	63
80	110 ^{h14}	20 ^{h14}	20 ^{e9}	100	35	99,5 ^{±2}	40 ^{0/-2}	M20x1.5	B70AE080	80
100	132 ^{h14}	25 ^{h14}	25 ^{e9}	122	45	112 ^{±2.5}	40 ^{0/-2}	M20x1.5	B70AE100	100
125	160 ^{h14}	25 ^{h14}	25 ^{e9}	150	45	132 ^{±2.5}	54 ^{0/-2}	M27x2	B70AE125	125
160	200 ^{h14}	32 ^{h14}	32 ^{e9}	190	45	152 ^{±2.5}	72 ^{0/-2}	M36x2	B70AE160	160
200	250 ^{h14}	32 ^{h14}	32 ^{e9}	235	45	167 ^{±2.5}	72 ^{0/-2}	M36x2	B70AE200	200
250	320 ^{h14}	40 ^{h14}	40 ^{e9}	312	55	184 ^{±2.5}	84 ^{0/-2}	M42x2	B70AE250	250
320	400 ^{h14}	50 ^{h14}	50 ^{e9}	385	70	207 ^{±2.5}	96 ^{0/-2}	M48x2	B70AE320	320

*Minimum dimension

ISO 1552 Cylinders Cylinder mountings

Pivot bracket for central trunnion - AF

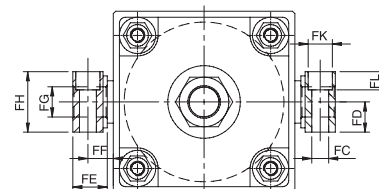
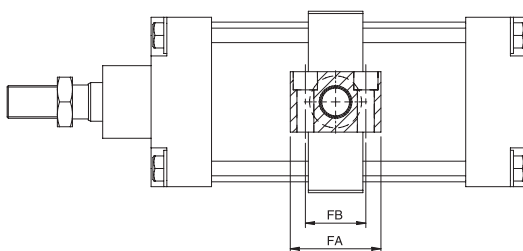
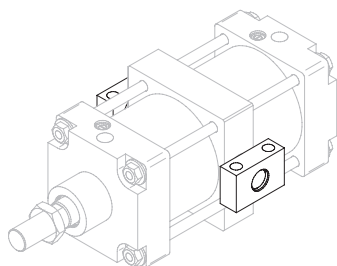

Ø	FA	FB	FC ^{H13}	FD	FE	FF	FG ^{H7}	FH	FK	FL	COD.	Ø
32	46	32 ^{±0,2}	6,6	15 ^{±0,1}	18	10,5	12	30	11	7	B70AF032	32
40	55	36 ^{±0,2}	9	18 ^{±0,1}	21	12	16	36	15	9	B70AF040	40
50	55	36 ^{±0,2}	9	18 ^{±0,1}	21	12	16	36	15	9	B70AF040	50
63	65	42 ^{±0,2}	11	20 ^{±0,1}	23	13	20	40	18	11	B70AF063	63
80	65	42 ^{±0,2}	11	20 ^{±0,1}	23	13	20	40	18	11	B70AF063	80
100	75	50 ^{±0,2}	14	25 ^{±0,1}	28,5	16	25	50	20	13	B70AF100	100
125	75	50 ^{±0,2}	14	25 ^{±0,1}	28,5	16	25	50	20	13	B70AF100	125
160	92	60 ^{±0,3}	18	30 ^{±0,2}	40	22,5	32	60	26	19	B70AF160	160
200	92	60 ^{±0,3}	18	30 ^{±0,2}	40	22,5	32	60	26	19	B70AF160	200
250	140	90 ^{±0,3}	22	35 ^{±0,2}	50	27,5	40	70	32	23	B70AF250	250
320	150	100 ^{±0,3}	26	40 ^{±0,2}	60	32,5	50	80	38	28	B70AF320	320

Intermediate trunnion for A705 Series - AE

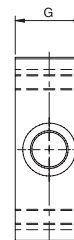
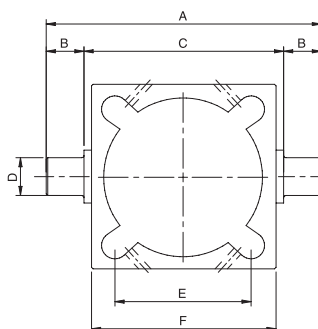
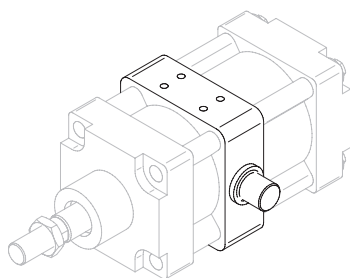

Ø	A	B	C	D	E	F	G	COD.	Ø
32	74	12	50	12	32,5	48,5	18	B81AE032	32
40	95	16	63	16	38	59	20	B81AE040	40
50	107	16	75	16	46,5	71	20	B81AE050	50
63	130	20	90	20	56,5	84	26	B81AE063	63
80	150	20	110	20	72	105	26	B81AE080	80
100	182	25	132	25	89	129	32	B81AE100	100

ISO 15552 Cylinders Cylinder mountings

Clevis bracket - AM

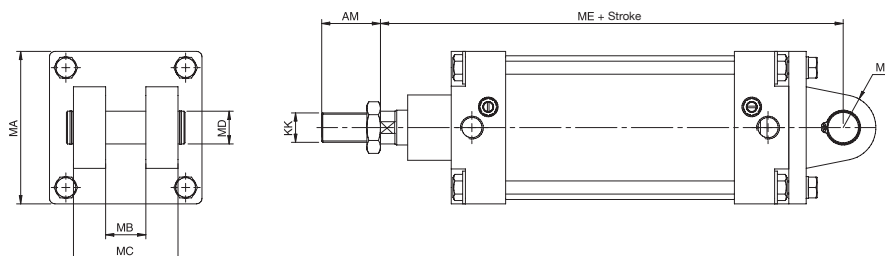
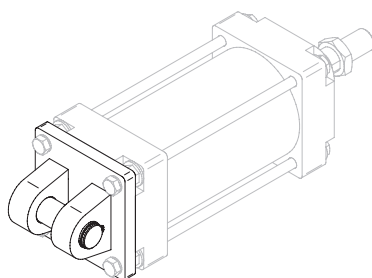

Ø	MA	MB	MC	MD	ME	MF	AM	KK	COD.	Ø
32	47	14 ^{H14}	34 ^{d12}	10 ^{H9}	142 ^{±1,25}	11	22 ^{0/-2}	M10X1,25	G70AM032	32
40	53	16 ^{H14}	40 ^{d12}	12 ^{H9}	160 ^{±1,25}	13	24 ^{0/-2}	M12X1,25	G70AM040	40
50	65	21 ^{H14}	45 ^{d12}	16 ^{H9}	170 ^{±1,25}	14	32 ^{0/-2}	M16X1,5	G70AM050	50
63	75	21 ^{H14}	51 ^{d12}	16 ^{H9}	190 ^{±1,6}	18	32 ^{0/-2}	M16X1,5	G70AM063	63
80	95	25 ^{H14}	65 ^{d12}	20 ^{H9}	210 ^{±1,6}	22	40 ^{0/-2}	M20X1,5	G70AM080	80
100	115	25 ^{H14}	75 ^{d12}	20 ^{H9}	230 ^{±1,6}	22	40 ^{0/-2}	M20X1,5	G70AM100	100
125	140	37 ^{H14}	97 ^{d12}	30 ^{H9}	275 ^{±2}	30	54 ^{0/-2}	M27X2	G70AM125	125
160	180	43 ^{H14}	122 ^{d12}	35 ^{H9}	315 ^{±2}	33	72 ^{0/-2}	M36X2	G70AM160	160
200	220	43 ^{H14}	122 ^{d12}	35 ^{H9}	335 ^{±2}	38	72 ^{0/-2}	M36X2	G70AM200	200
250	275	49 ^{H14}	125 ^{d12}	40 ^{H9}	375 ^{±2}	42	84 ^{0/-2}	M42X2	G70AM250	250
320	345	60 ^{H14}	150 ^{d12}	50 ^{H9}	420 ^{±2,5}	52	96 ^{0/-2}	M48X2	G70AM320	320

Pivot bracket with swivel bearing - AR

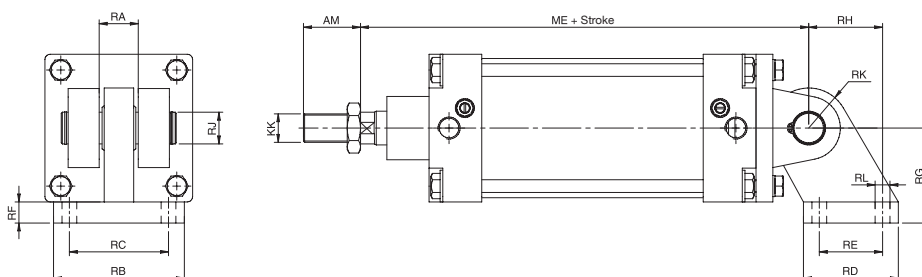
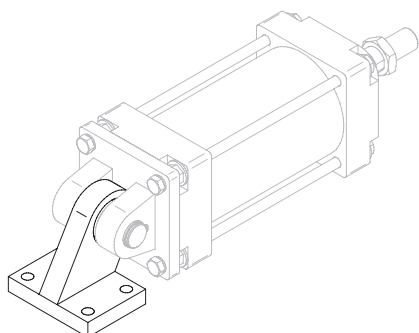

Ø	RA	RB	RC	RD	RE	RF	RG	RH	RJ	RK	RL	ME	AM	KK	COD.	Ø
32	14 ^{+0/-0,1}	51	38 ^{JS14}	31 ^{JS15}	18 ^{JS14}	10	32 ^{JS14}	21 ^{JS14}	10 ^{H9}	15	6,6 ^{H13}	142 ^{±1,25}	22 ^{0/-2}	M10X1,25	G70AR032	32
40	16 ^{+0/-0,1}	54	41 ^{JS14}	35 ^{JS15}	22 ^{JS14}	10	36 ^{JS14}	24 ^{JS14}	12 ^{H9}	17	6,6 ^{H13}	160 ^{±1,25}	24 ^{0/-2}	M12X1,25	G70AR040	40
50	21 ^{+0/-0,1}	65	50 ^{JS14}	45 ^{JS15}	30 ^{JS14}	12	45 ^{JS14}	33 ^{JS14}	16 ^{H9}	20	9 ^{H13}	170 ^{±1,25}	32 ^{0/-2}	M16X1,5	G70AR050	50
63	21 ^{+0/-0,1}	67	52 ^{JS14}	50 ^{JS15}	35 ^{JS14}	12	50 ^{JS14}	37 ^{JS14}	16 ^{H9}	22	9 ^{H13}	190 ^{±1,6}	32 ^{0/-2}	M16X1,5	G70AR063	63
80	25 ^{+0/-0,1}	86	66 ^{JS14}	60 ^{JS15}	40 ^{JS14}	14	63 ^{JS14}	47 ^{JS14}	20 ^{H9}	26	11 ^{H13}	210 ^{±1,6}	40 ^{0/-2}	M20X1,5	G70AR080	80
100	25 ^{+0/-0,1}	96	76 ^{JS14}	70 ^{JS15}	50 ^{JS14}	15	71 ^{JS14}	55 ^{JS14}	20 ^{H9}	30	11 ^{H13}	230 ^{±1,6}	40 ^{0/-2}	M20X1,5	G70AR100	100
125	37 ^{+0/-0,1}	124	94 ^{JS14}	90 ^{JS15}	60 ^{JS14}	20	90 ^{JS14}	70 ^{JS14}	30 ^{H9}	38	14 ^{H13}	275 ^{±2}	54 ^{0/-2}	M27X2	G70AR125	125
160	43 ^{+0/-0,1}	156	118 ^{JS14}	115 ^{JS15}	88 ^{JS14}	25	115 ^{JS14}	97 ^{JS14}	35 ^{H9}	42	14 ^{H13}	315 ^{±2}	72 ^{0/-2}	M36X2	G70AR160	160
200	43 ^{+0/-0,1}	162	122 ^{JS14}	135 ^{JS15}	90 ^{JS14}	30	135 ^{JS14}	105 ^{JS14}	35 ^{H9}	45	18 ^{H13}	335 ^{±2}	72 ^{0/-2}	M36X2	G70AR200	200
250	49 ^{+0/-0,1}	200	150 ^{JS14}	165 ^{JS15}	110 ^{JS14}	35	165 ^{JS14}	128 ^{JS14}	40 ^{H9}	48	22 ^{H13}	375 ^{±2}	84 ^{0/-2}	M42X2	G70AR250	250
320	60 ^{+0/-0,1}	234	170 ^{JS14}	200 ^{JS15}	122 ^{JS14}	40	200 ^{JS14}	150 ^{JS14}	50 ^{H9}	59	26 ^{H13}	420 ^{±2,5}	96 ^{0/-2}	M48X2	G70AR320	320

ISO 1552 Cylinders Cylinder mountings

Rear bracket with swivel bearing - AW

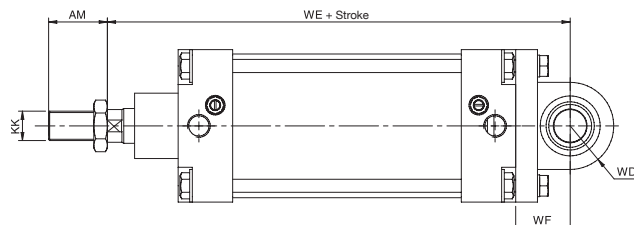
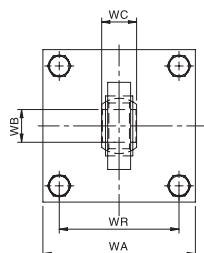
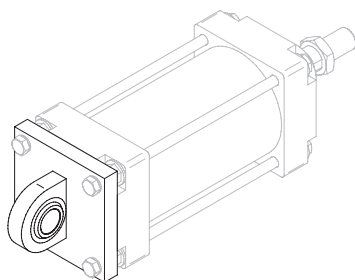

Ø	WB	WC	WD	WE	WF	WA	WR	AM	KK	COD.	Ø
32	10 ^{H7}	14 ^{±0.1}	15	142	22 ^{±0.2}	47	32,5	22 ^{0/-2}	M10X1,25	G70AW032	32
40	12 ^{H7}	16 ^{±0.1}	17	160	25 ^{±0.2}	54	38	24 ^{0/-2}	M12X1,25	G70AW040	40
50	16 ^{H7}	21 ^{±0.1}	19	170	27 ^{±0.2}	66,5	46,5	32 ^{0/-2}	M16X1,5	G70AW050	50
63	16 ^{H7}	21 ^{±0.1}	22	190	32 ^{±0.2}	76,5	56,5	32 ^{0/-2}	M16X1,5	G70AW063	63
80	20 ^{H7}	25	26	210	36 ^{±0.2}	95	72	40 ^{0/-2}	M20X1,5	G70AW080	80
100	20 ^{H7}	25	28	230	41 ^{±0.2}	115	89	40 ^{0/-2}	M20X1,5	G70AW100	100
125	30 ^{H7}	37	40	275	50 ^{±0.2}	140	110	54 ^{0/-2}	M27X2	G70AW125	125
160	35 ^{H7}	43	42	315	55 ^{±0.2}	180	140	72 ^{0/-2}	M36X2	G70AW160	160
200	35 ^{H7}	43	47	335	60 ^{±0.2}	220	175	72 ^{0/-2}	M36X2	G70AW200	200
250	40 ^{H7}	49	48	375	70 ^{±0.2}	275	220	84 ^{0/-2}	M42X2	G70AW250	250
320	50 ^{H7}	60	58	420	80 ^{±0.2}	345	270	96 ^{0/-2}	M48X2	G70AW320	320

Bracket - AY

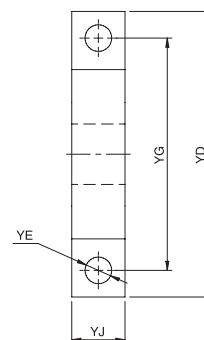
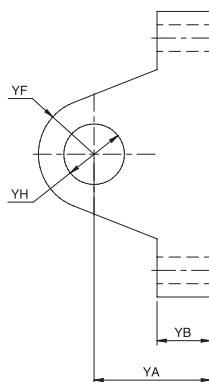

YA	YB	YD	YE	YF	YG	YH	YJ	COD.
35	16	82	9	14	65	16 ^{H7}	16	B70AY080
40	19	99	9	19	80	20 ^{H7}	19	B70AY100
48	22	118	11	23	96	25 ^{H7}	22	B70AY125
57	28	142	13	28	114	30 ^{H7}	26	B70AY160
70	32	172	17	33	140	35 ^{H7}	32	B70AY200

ISO 1552 Cylinders

Cylinder mountings

Swivel rod eye - AH DIN ISO 8139

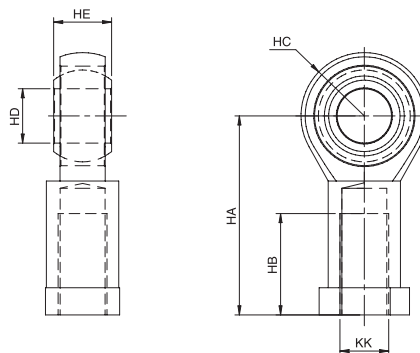
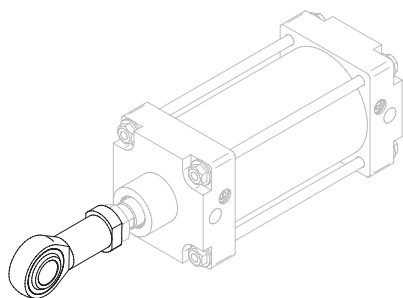

Ø	HA	HB	HC	HD	HE	KK	COD.	Ø
32	43	20	13,5	10 ^{H9}	14 ^{h12}	M10X1,25	C70AH032	32
40	50	22	15,5	12 ^{H9}	16 ^{h12}	M12X1,25	C70AH040	40
50	64	28	20,5	16 ^{H9}	21 ^{h12}	M16X1,5	C70AH050	50
63	64	28	20,5	16 ^{H9}	21 ^{h12}	M16X1,5	C70AH050	63
80	77	33	23,5	20 ^{H9}	25 ^{h12}	M20X1,5	C70AH080	80
100	77	33	23,5	20 ^{H9}	25 ^{h12}	M20X1,5	C70AH080	100
125	110	51	36,5	30 ^{H9}	37 ^{h12}	M27X2	C70AH125	125
160	125	56	39	35 ^{H9}	43 ^{h12}	M36X2	C70AH160	160
200	125	56	39	35 ^{H9}	43 ^{h12}	M36X2	C70AH160	200
250	142	70	47	40 ^{H7}	49 ^{h12}	M42X2	C70AH250	250
320	160	80	56	50 ^{H7}	60 ^{h12}	M48X2	C70AH320	320

Clevis - AG ISO 8140 / DIN 71752

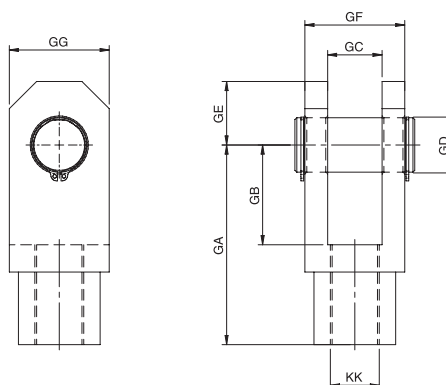
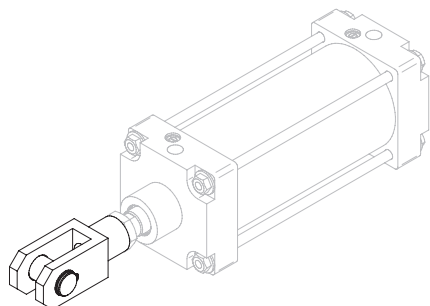

Ø	GA	GB	GC	GD	GE	GF	GG	KK	COD.	Ø
32	40	20	10 ^{+0,2/+0,4}	10	12	20	20	M10X1,25	G70AG032	32
40	48	24	12 ^{+0,2/+0,4}	12	14	24	24	M12X1,25	G70AG040	40
50	64	32	16 ^{+0,2/+0,4}	16	19	32	32	M16X1,5	G70AG050	50
63	64	32	16 ^{+0,2/+0,4}	16	19	32	32	M16X1,5	G70AG050	63
80	80	40	20 ^{+0,2/+0,4}	20	25	40	40	M20X1,5	G70AG080	80
100	80	40	20 ^{+0,2/+0,4}	20	25	40	40	M20X1,5	G70AG080	100
125	110	55	30 ^{+0,2/+0,4}	30	35	55	55	M27X2	G70AG125	125
160	144	72	35 ^{+0,2/+0,4}	35	44	70	70	M36X2	G70AG160	160
200	144	72	35 ^{+0,2/+0,4}	35	44	70	70	M36X2	G70AG160	200
250	168	84	40 ^{+0,2/+0,4}	40	64	85	85	M42X2	G70AG250	250
320	192	96	50 ^{+0,2/+0,4}	50	73	96	96	M48X2	G70AG320	320

ISO 15552 Cylinders Cylinder mountings

Locknut

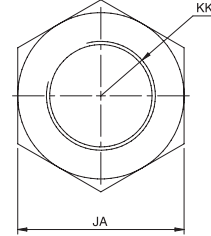
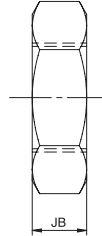
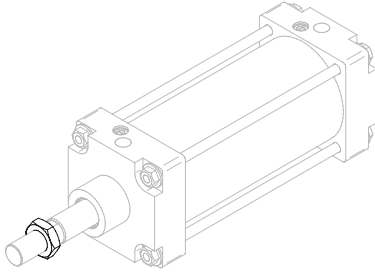

Ø	JA	JB	KK	COD.	Ø
32	17	6	M10X1,25	700310	32
40	19	7	M12X1,25	700410	40
50	24	8	M16X1,5	260410	50
63	24	8	M16X1,5	260410	63
80	30	9	M20X1,5	260610	80
100	30	9	M20X1,5	260610	100
125	41	12	M27X2	261010	125
160	55	14	M36X2	261610	160
200	55	14	M36X2	261610	200
250	65	16	M42X2	702510	250
320	75	18	M48X2	703210	320

Other accessories

Static or dynamic rod lock

A89 Series

ISO 15552 (ISO 6431) · VDMA 24562 · ISO 6432

Ø 20 ... 125 mm static and Ø 32 ... 100 mm dynamic
High Temperature versions available



Guide units

H Type

ISO 15552 (ISO 6431) · VDMA 24562 · ISO 6432

Ø 12 ... 100 mm
Available in stainless steel version



U Type

ISO 15552 (ISO 6431) · VDMA 24562 · ISO 6432

Ø 12 ... 100 mm
Available in stainless steel version



AT70 Series

Stainless steel tie rod cylinders

► ISO 15552 (ISO 6431) · VDMA 24562

The stainless steel cylinders are double acting cylinders manufactured according to European standard ISO 15552. These cylinders are particularly suitable for aggressive environments, naval industry and food industry. Available from 32 to 200 mm bore.



* A T 70 * * * A * * * * M *

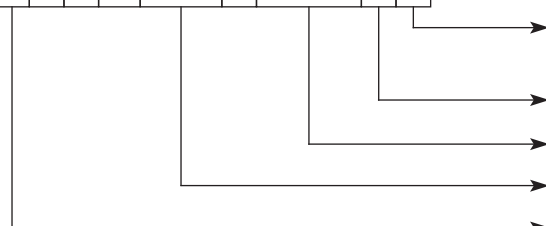

Codification

1	With one detector	Version	-
2	With two detectors		
M	Magnetic	4	
	Stroke (mm)		
	Internal bore (mm)		
-	Double acting		
4	Through rod		
6	Rod lock		

Strokes

All strokes available according to the customer's needs.

Technical specifications

Fluid	Lubricated or non lubricated air
Operating temperature range	-20°C → +80°C
Max operating pressure	10 bar
Forces	Page 4
Air consumption	Page 5

For further information, please contact our technical department.

Other pneumatic cylinders we have

ISO 6432 Cylinders

A83 Series

ISO 6432
Ø 8 ... 25 mm
Single or Double acting



AT83 Series

Stainless steel
ISO 6432
Ø 16 ... 25 mm
Single or Double acting



CNOMO Cylinders

MS Series

Ø 25 ... 300 mm
Double acting



MS Series

Ø 25 ... 300 mm
Double acting



MS Series

Ø 25 ... 300 mm
Double acting



Heavy Duty Cylinders

30-35 Series

Ø 50 ... 300 mm
Double acting



30-35 Series

Ø 50 ... 300 mm
Double acting



Special Cylinders

Cylinders designed and manufactured according to customer's requirements



Hydraulic cylinders

According to standard ISO 6020/1, 6020/2, 3320 and specials



Pneumatic panels and cabinets





further information at...

www.aircontrol.es
www.aircontrol-metals.com

FACTORY AND HEADQUARTER

- DONOSTIA-SAN SEBASTIÁN
Paseo Sarroeta, 4
E-20014 Donostia-San Sebastián
Tel.: (+34) 943 44 50 80
Fax: (+34) 943 44 51 53
E-mail: info@aircontrol.es

COMMERCIAL OFFICES

- BARCELONA
Ramón Albó 71-73
E-08027 Barcelona
Tel.: (+34) 93 498 81 30
Fax: (+34) 93 408 41 08
E-mail: info@aircontrol.es
- SEVILLA
REINSUR S.L.
Avda. Alcalde Luis Uruñuela s/n
Edificio Congreso, Mod. 421
E-41020 Sevilla
Tel.: (+34) 95 425 85 17
Fax: (+34) 95 425 85 17
E-mail: reinsur_sl@yahoo.es
- LISBOA (PORTUGAL)
Alameda Fernão Lopes 31 A, Torre 2 - Miraflores
P-1495-136 Algés (Lisboa)
Tel.: (+351) 21 410 13 57
Fax: (+351) 21 410 56 08
E-mail: geral@air-control.pt



Distributed by :