

APPLICAZIONI

Elettropompe per drenaggio con girante tipo monocanale chiusa che assicura ampi passaggi liberi ed elevate prestazioni.

Adatta per la movimentazione di liquidi fognari e biologici carichi, fanghi attivi e per liquidi non depurati da griglie, per scarichi di origine civile ed industriali.

LIMITI D'IMPIEGO

- Temperatura liquido fino a 35°C
(per un uso domestico secondo EN 60335-2-41)
Temperatura max. liquido: 50°C (per altri impieghi)
- Massima profondità d'immersione 20 mt.
(con cavo di adatta lunghezza)
- Passaggio solidi Ø 40 mm
- Livello min. d'aspirazione 70 mm
- Servizio continuo

MOTORE

- Isolamento Classe F
- Protezione IP 68
- Protettore termico (solo monofase)

MATERIALI

- Corpo motore Ghisa
- Corpo pompa Ghisa
- Girante Ghisa
- Albero motore Acciaio Inox AISI 304
- Doppia tenuta meccanica in camera d'olio Ceramica/Grafite/NBR
Silicio/Silicio/NBR

OPERATING CONDITIONS

- Liquid temperature up to 35°C
(for home use according to EN 60335-2-41)
Temperature max. liquid: 50°C (for other uses)
- Maximum immersion depth 20 mt.
(with a cable of the appropriate length)
- Grain size inlet Ø 40 mm
- Min. suction level 70 mm
- Continuous duty

MOTOR

- Insulation Class F
- Protection IP 68
- Thermic protection (only single-phase)

MATERIALS

- Motor body Cast Iron
- Pump body Cast Iron
- Impeller Cast Iron
- Shaft with rotor Stainless Steel AISI 304
- Double mechanical seal in oil chamber Ceramic/Graphite/NBR
Silicon/Silicon/NBR

APPLICATION

Submersible drainage pumps with closed single-blade impeller, which allows free passage of suspended parts and high performance.

Suitable in civil and industrial water systems, for cesspool drainage with dirty and muddy liquids and for waters not cleaned by grid.

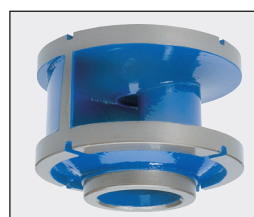

INCLUSO NEI MODELLI
MONOFASE
INCLUDED IN THE
SINGLE-PHASE MODELS



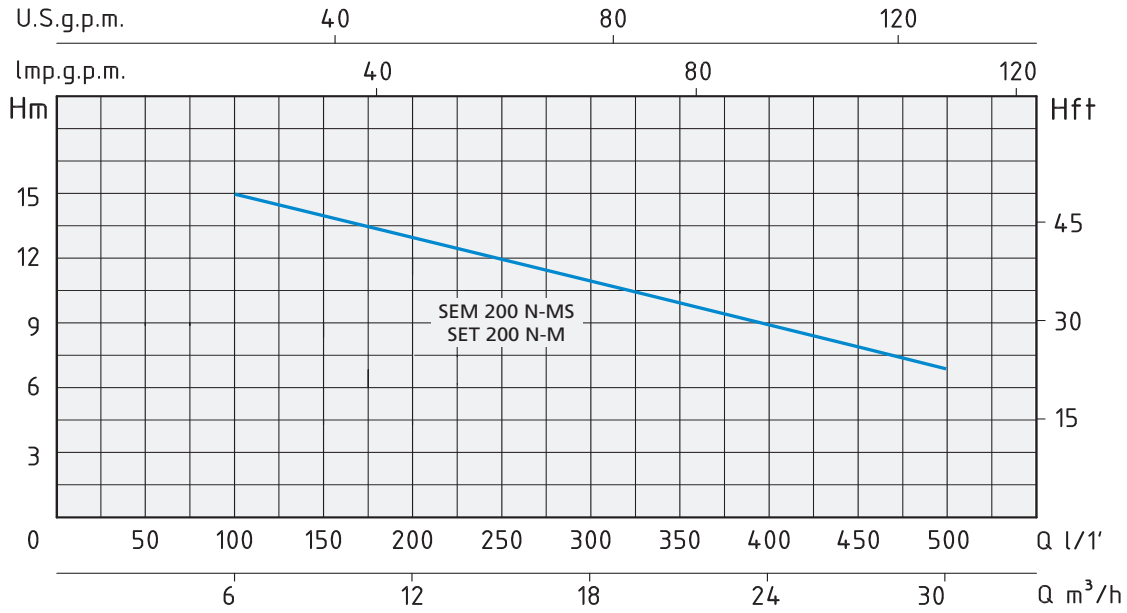

TIPO TYPE		POTENZA NOMINALE NOMINAL POWER		POTENZA ASSORBITA INPUT POWER	AMPERE		Q = PORTATA - CAPACITY									
Monofase Single-phase	Trifase Three-phase	P2		P1	Monofase Single-phase	Trifase Three-phase	m³/h	6	9	12	15	18	21	24	27	30
		HP	kW	kW			l/1'	100	150	200	250	300	350	400	450	500
230V-50Hz	230/400V-50Hz				1 x 230V	3 x 400V	Prevalenza manometrica totale in m.C.A. - Total head in meters w.c.									
SEM 200 N-MS	SET 200 N-M	2	1,5	1,9	8,5	3,5	H (m)	15	14	13	12	11	10	9	8	7

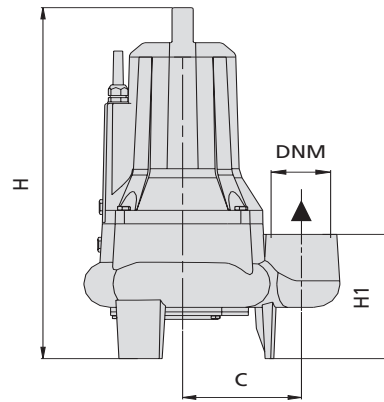
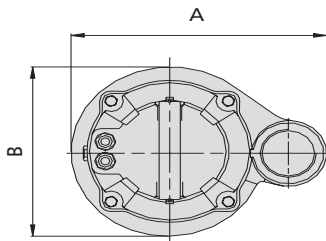

TIPO TYPE		DIMENSIONI mm - DIMENSIONS mm								DIMENSIONI DIMENSIONS mm	PESO WEIGHT		
Monofase Single-phase	Trifase Three-phase	A	B	C	H	H1	DNM	CAVO CABLE	Passaggio solidi (mm) Grain size inlet (mm)	P	L	H	Kg
		SEM 200 N-MS	SET 200 N-M	292	225	135	495	165	2"	10 mt H07RN8-F	Ø 40	280	350