

Axial Piston Pump for High Pressure Application

NOVA Pump

Type Series Booklet



Legal information/Copyright

Type Series Booklet NOVA Pump

All rights reserved. The contents provided herein must neither be distributed, copied, reproduced, edited or processed for any other purpose, nor otherwise transmitted, published or made available to a third party without the manufacturer's express written consent.

Subject to technical modification without prior notice.

© Salinnova GmbH, Bobenheim-Roxheim 24.03.2016

Contents

Water: Water Treatment4

 Seawater desalination module4

 NOVA Pump4

 Main applications4

 Operating data4

 Designation4

 Design details4

 Configuration and function5

 Materials6

 Coating and preservation6

 Product benefits6

 Characteristic curves6

 NOVA Pump Performance Curves.....7

 Dimensions and Connections NOVA P60.....8

 Dimensions and Connections NOVA P60/P180.....9/10

 Connections.....11

 Filtration.....11

 Scope of supply11

 Exploded view with part list.....12/13

Water: Water Treatment

Axial Piston Pump

NOVA Pump



Main applications

- Seawater desalination by reverse osmosis (RO)
- Firefighting water mist system
- Humidification, high pressure cutting, power plants

Operating data

Characteristic NOVA		Value
Flow rate	Q [m ³ /h]	0,6 - 72
Fluid temperature	T [°C]	2 - 50
Operating pressure	p [bar]	5 - 160 ¹⁾

Designation

Example: NOVA P60 – 316L (DSS)

Key to the designation

Code	Description
NOVA	Type series
PC	Design
	PC Pump direction of rotation clockwise
60	Displacement in ccm / rev
316L	Material of construction
DSS	Option: DSS on request
	DSS Duplex Stainless Steel

Design details

Design

- Hydraulic unit comprising axial piston pump and electrical motor
- Swash plate design with fluid lubricated bearings
- Number of pistons
 - Axial piston pump: 9
- Horizontal or vertical installation
- ATEX certified / MOC acc. to FDA

Shaft seal

- Lip Seal or Mechanical seal

Static sealing elements

- The elastomer type used for the static seals is NBR.

Bearings

- Product-lubricated plain bearings
- The bearings' service life depends on the operating conditions and the fluid's level of purity.

Automation

- Automation equipment is fitted at the place of use and will be tailored to the individual system requirements by the engineering contractor.

Connections NOVA

- Main connections: 3/4" or 1" BSPP or 2" SAE Flange, 3000 psi
- Drain G 3/4" BSPP

Design NOVA

- Up to 1800 rpm unboosted
- 1800 rpm < n < 2000 rpm boosted

1) Higher operating pressures on request

Configuration and function

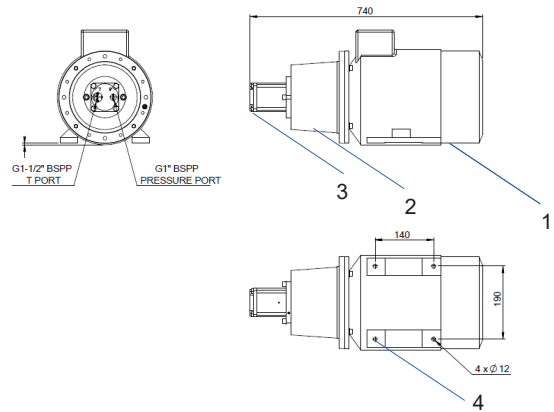

NOVA

1	Electric motor	2	Bell housing
3	NOVA	4	Mounting frame

Design

The axial piston pump with is designed with axial fluid inlets and outlets. The hydraulic system is connected to the motor by a coupling. The Motor is controlled by a frequency inverter. The pump including motor is fitted to a mounting frame.

Function

The axial piston pump transmits the electric motor's mechanical energy to the feed water/ brackish water which is pumped through e.g. the RO membrane, separating the drinking water and leaving the feed water as concentrated brine. The high energy content of this concentrated brine is then redirected to a separate tank. In case of fire fighting, or any other application, kindly contact SALINNOVA.

Sealing

The pump is sealed by a mechanical seal.

Materials

Overview of available materials

Description	Material variant	
	D	
Bell housing	EN-GJL	
Mounting frame	1.4571 / steel galvanized	
Coupling	EN-GJL / ST	
Screw/bolt	V4A	
Nut	V4A	
Spring lock washer	V4A	

Codes used

Code	Material	
D / SD	Duplex stainless steel / Super Duplex stainless steel on request	1.4462
EN-GJL	Grey cast iron	-
Steel	Steel	-
V4A	Stainless steel	1.4401

Coating and preservation

- Coating and preservation according to SALINNOVA's standard

Product benefits

- Economically efficient
 - Low investment and maintenance costs thanks to axial piston pump technology
 - Low operating costs thanks to maximum energy efficiency
 - Plug & Run: the system's compact design allows straightforward handling
- Environment-friendly and clean thanks to lubrication by the fluid handled
- Reliable and safe thanks to tried and tested axial piston technology

Characteristic curves (for NOVA P1 and P3: on request)

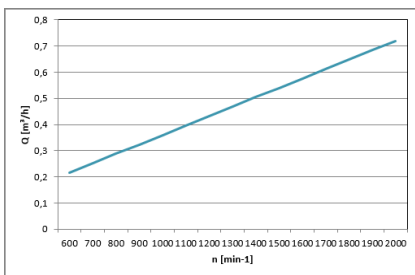

NOVA P6@ 6 ccm / rev; also in 4,6 ccm / rev. available

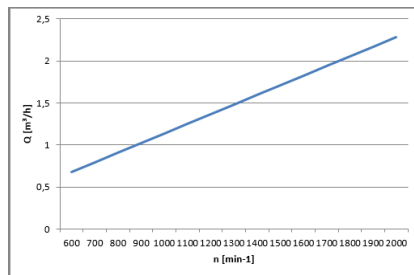

NOVA P15@ 19 ccm / rev; also in 12 and 15 ccm / rev. available

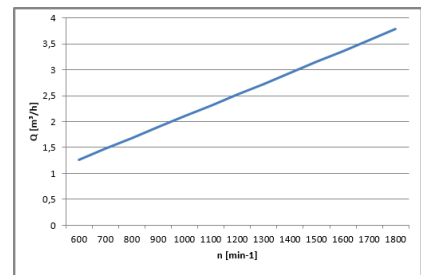

NOVA P30@ 35 ccm / rev; also in 23 and 30 ccm / rev. available

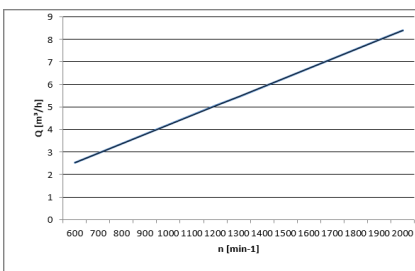

NOVA P60@ 70 ccm / rev; also in 51 and 63 ccm / rev. available

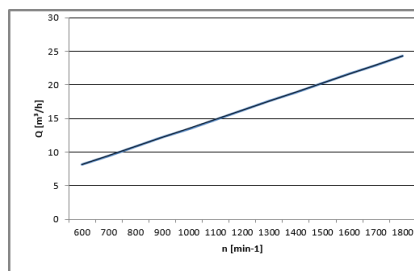

NOVA P180@ 225 ccm / rev; also in 134 and 180 ccm / rev. available

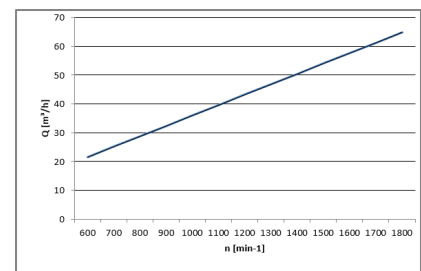

NOVA P500@ 600 ccm / rev

Overall Efficiency (for NOVA P1 and P3: on request)

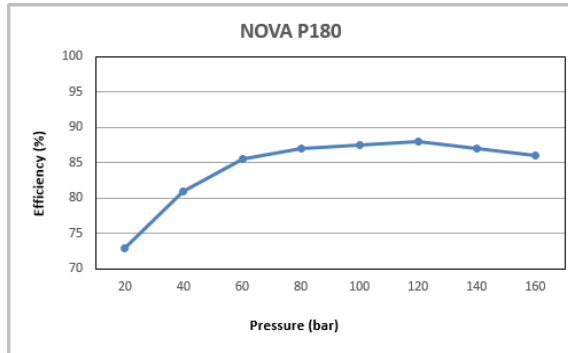
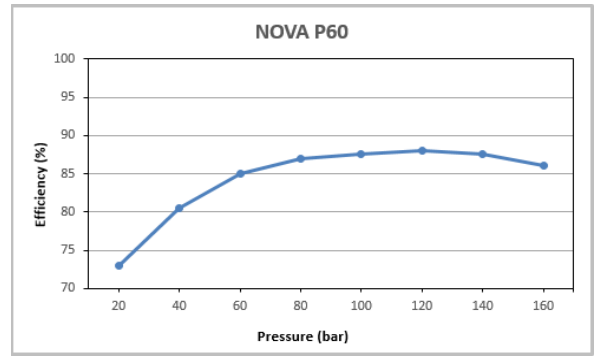
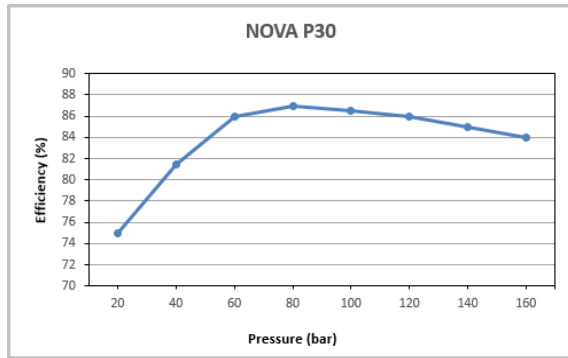
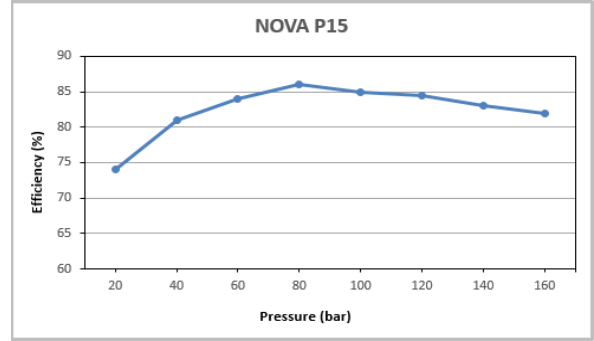
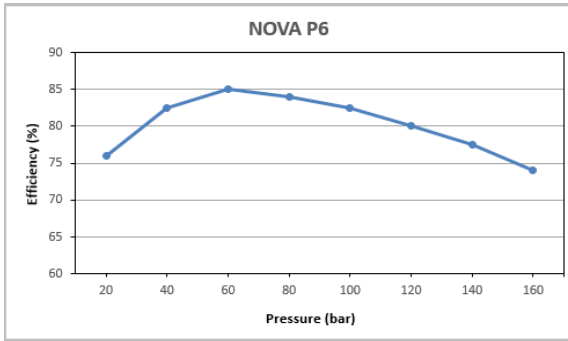

Dimensions and connections NOVA P60 with 4 kW motor

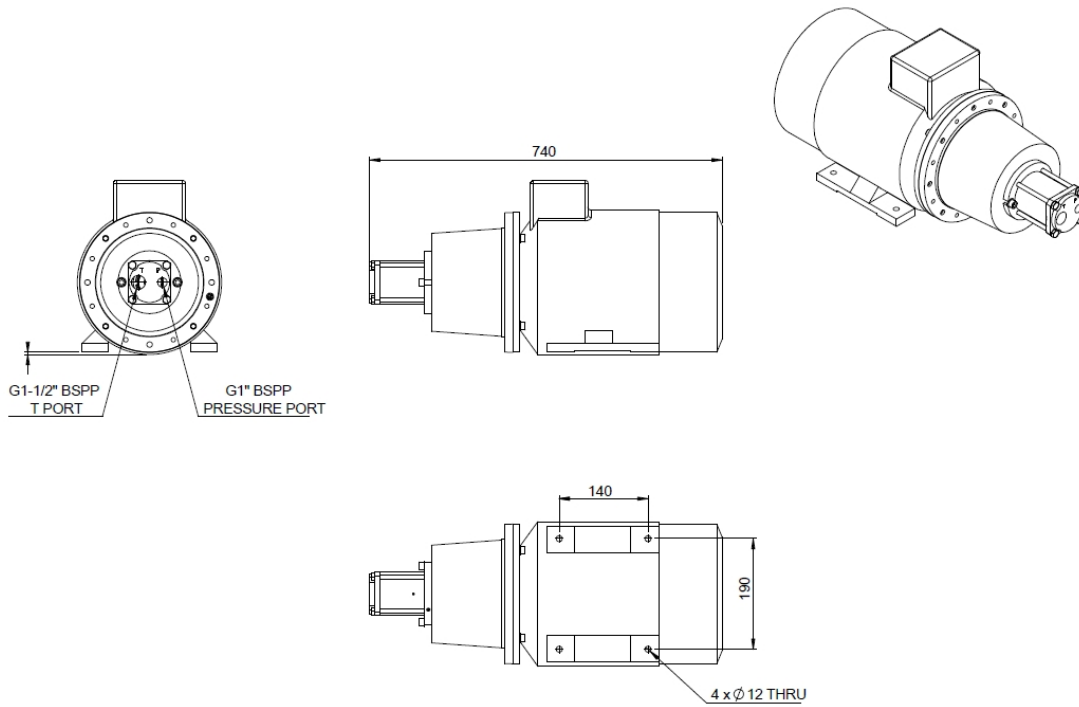

Dimensions of NOVA P60, unboosted; Dimensions of NOVA P1, P3, P6, P15, P60, P180, P500 on request
Dimensions of mounting frame (on request)

Dimensions and connections NOVA P60 with 37 kW motor

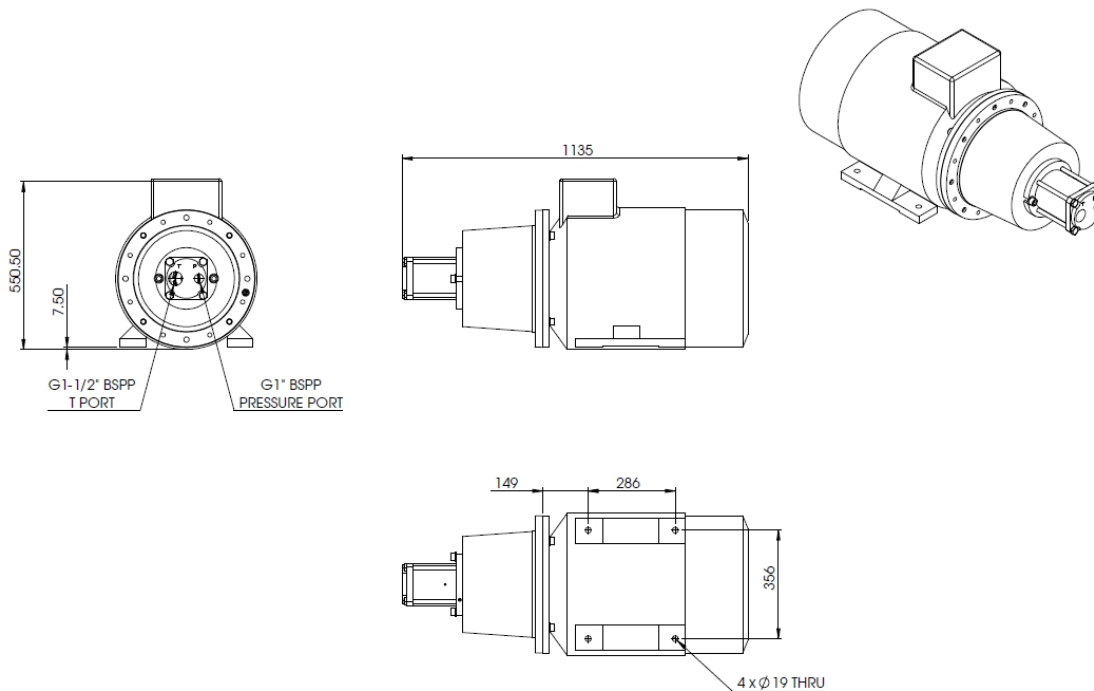

Dimensions and connections NOVA P60 bare shaft

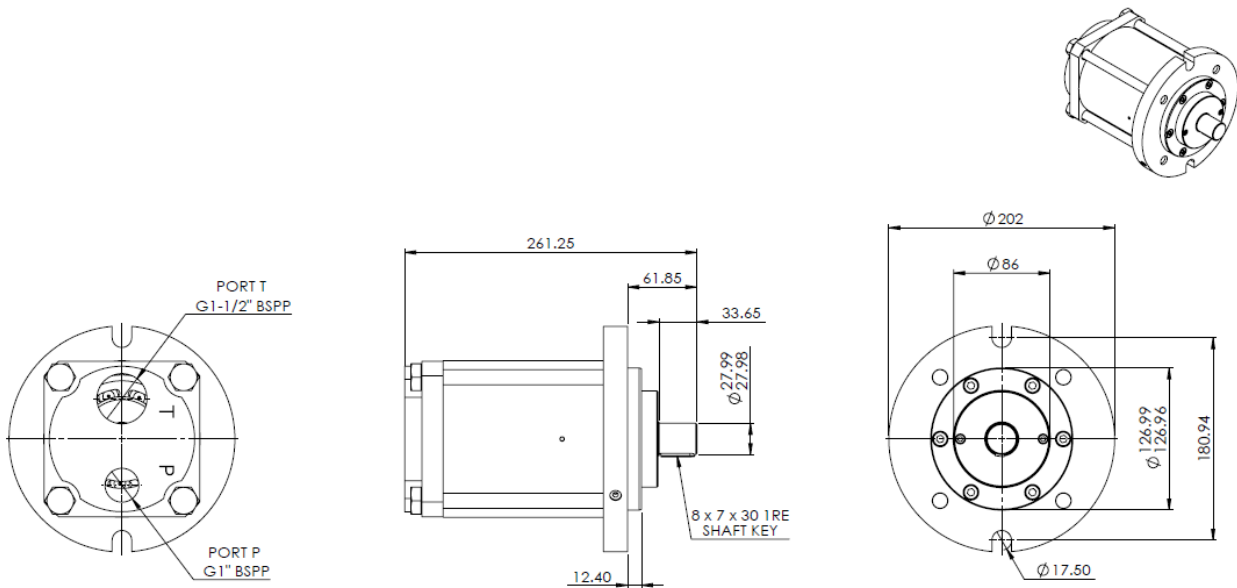

Dimensions and connections NOVA P180 bare shaft

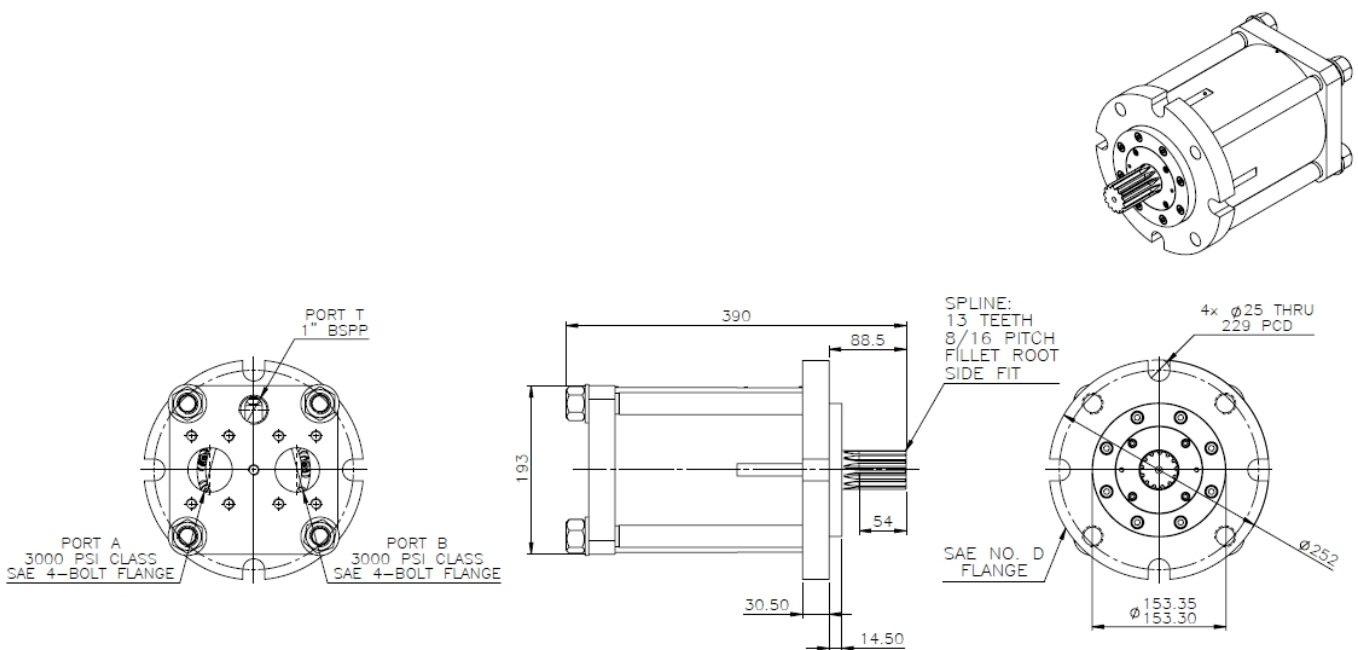

Dimensions and connections NOVA P60 bare shaft

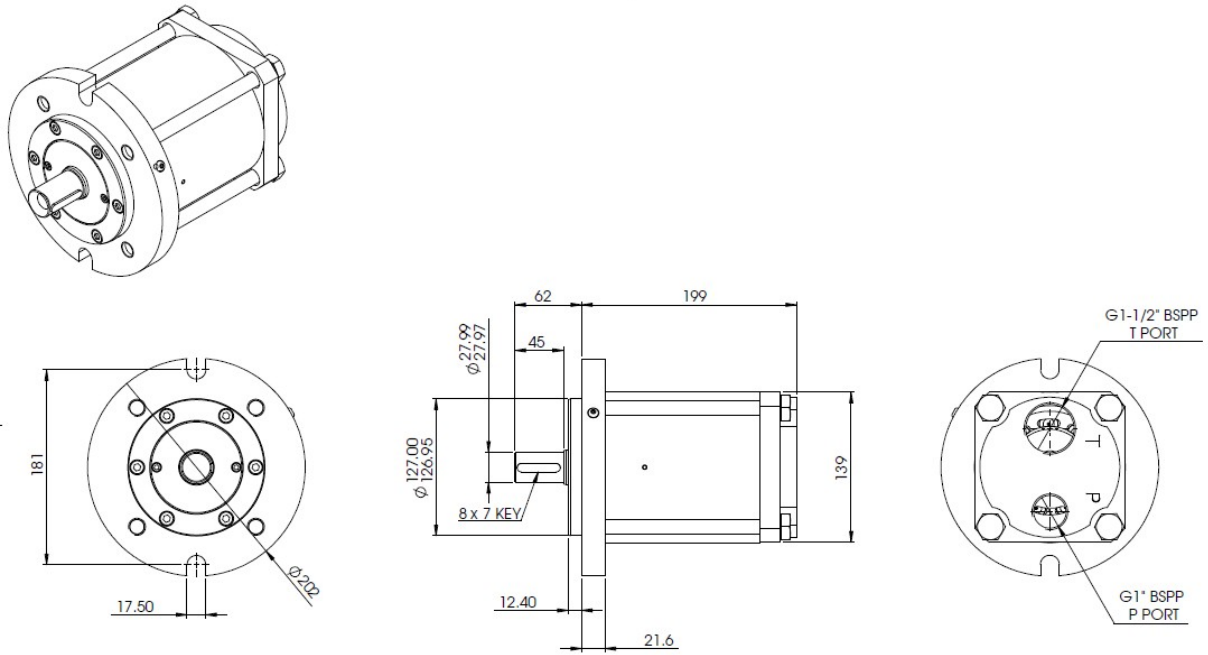

Overall Dimensions and connections NOVA P180- with 37 kW motor

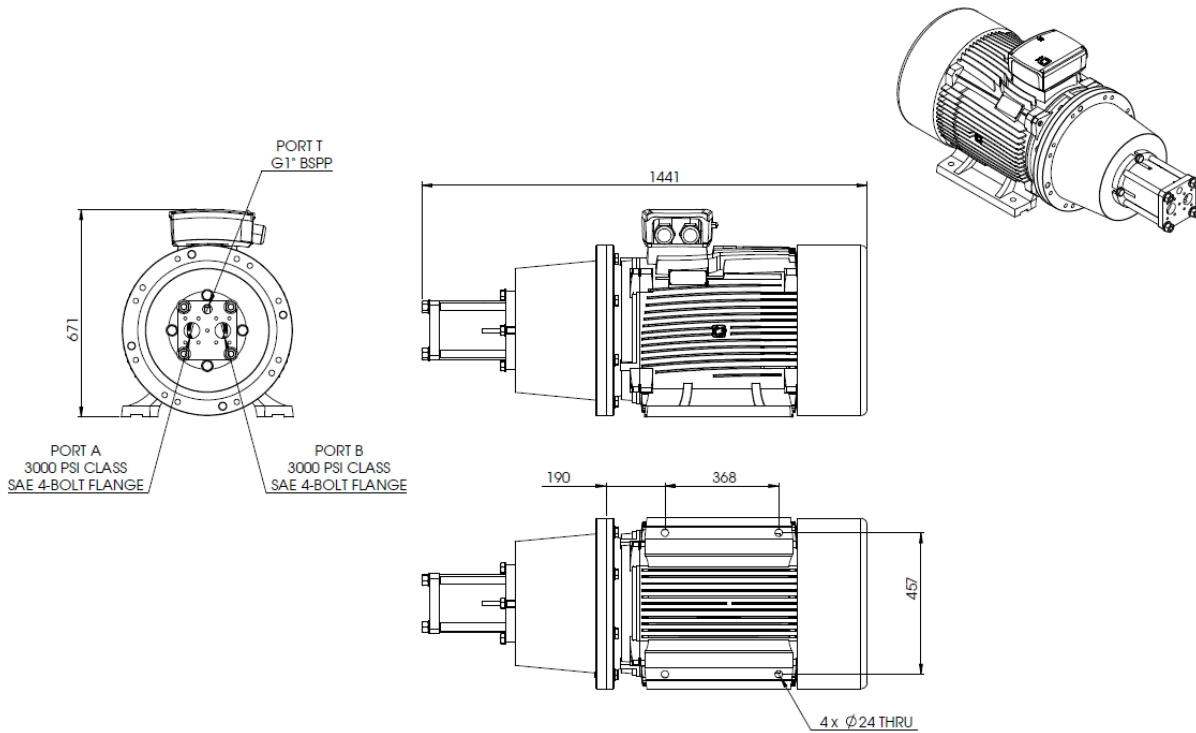

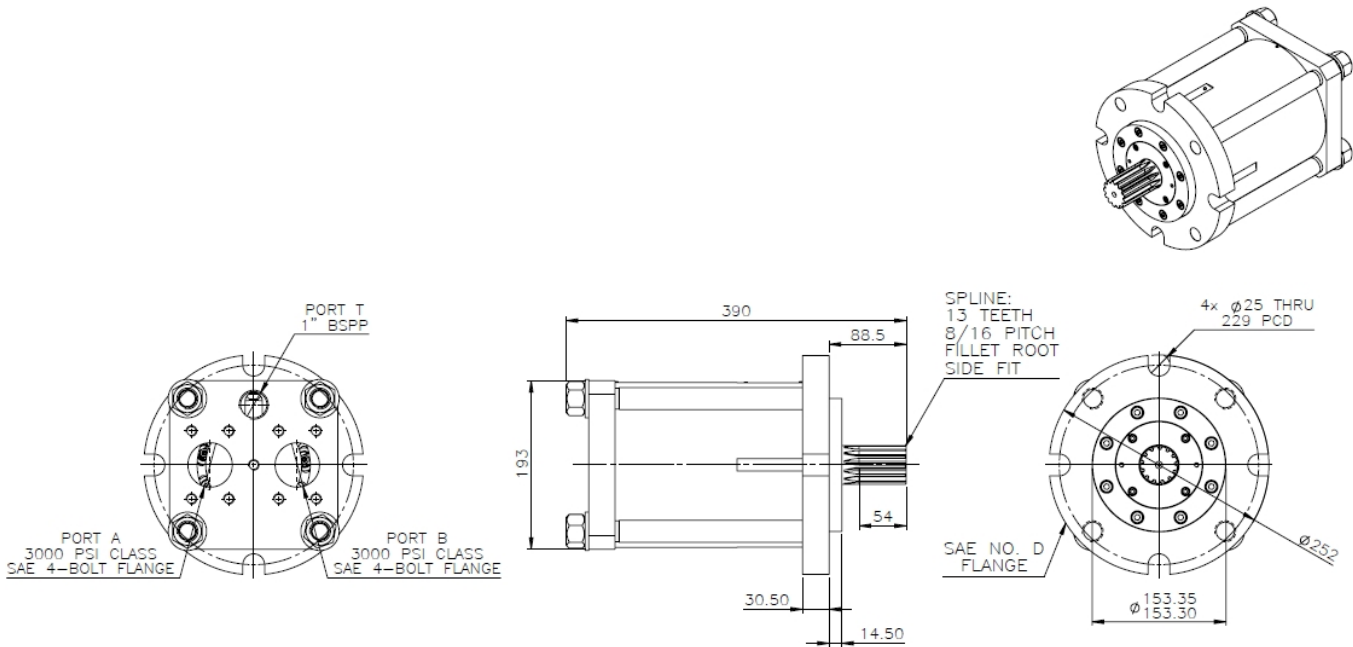

Dimensions of NOVA P180, boosted; Dimensions and connections

Connections

T	"Low Pressure In" connection of pump with tank
P	"High Pressure Out" connection of pump with system
C	connection flange with bellhousing
D	Centration flange with bellhousing
E	Drain connection of pump, G 3/4

Filtration

To ensure that the pump's service life is as long as possible, the fluid handled must be filtered before it flows through the pump. This requires filters with a minimum filtration ratio of $\beta_{10} > 1000$ which means that 100 of 100,000 particles sized 10 μm will pass through the filter (absolute rating).

- Shaft coupling
- Bell housing
- Mounting frame
 - Welded with V4A stainless steel

Scope of supply

Depending on the model, the following items are included in the scope of supply:

- High-pressure component
NOVA
- Drive
 - Electric motor
 - Frequency inverter / Solar Drive Inverter on request

Exploded view and list of components NOVA P60

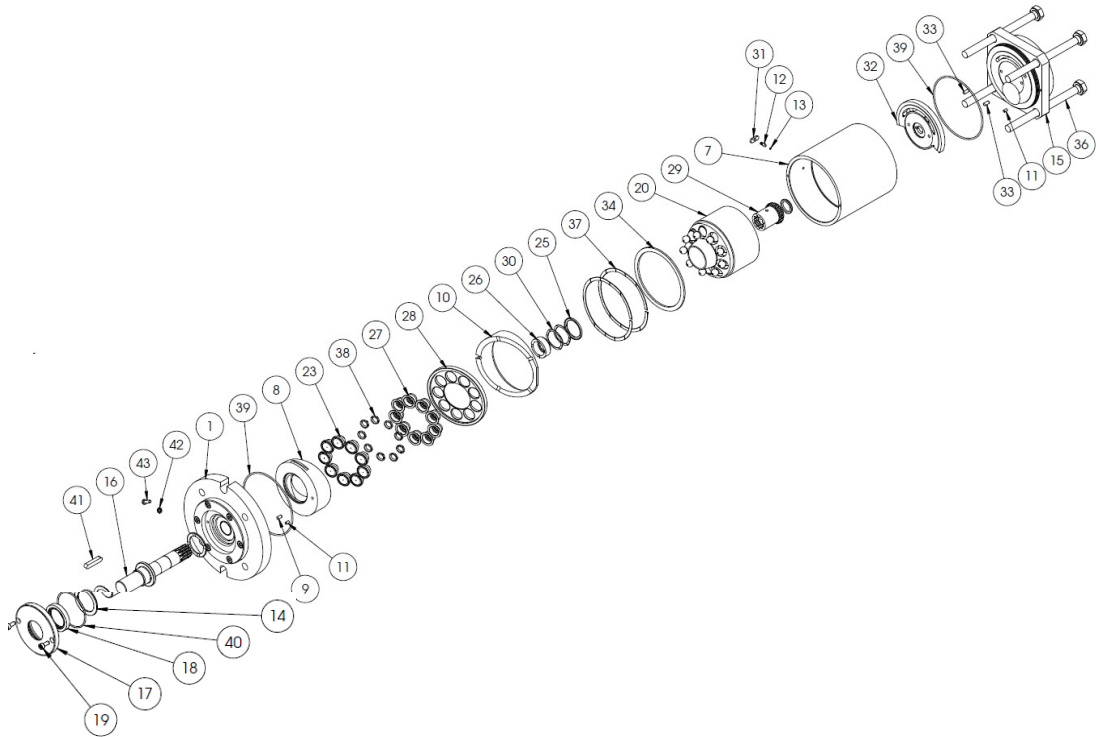

Exploded view and list of components NOVA P180 (for part nos. Pls. refer to NOVA P60)

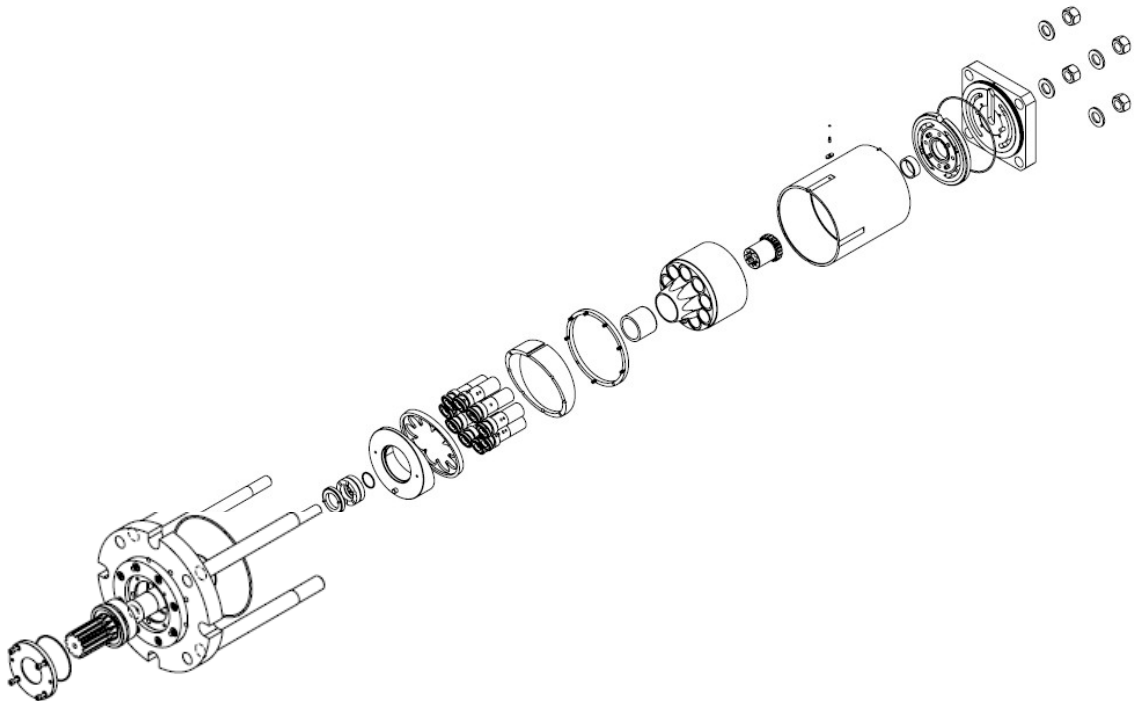

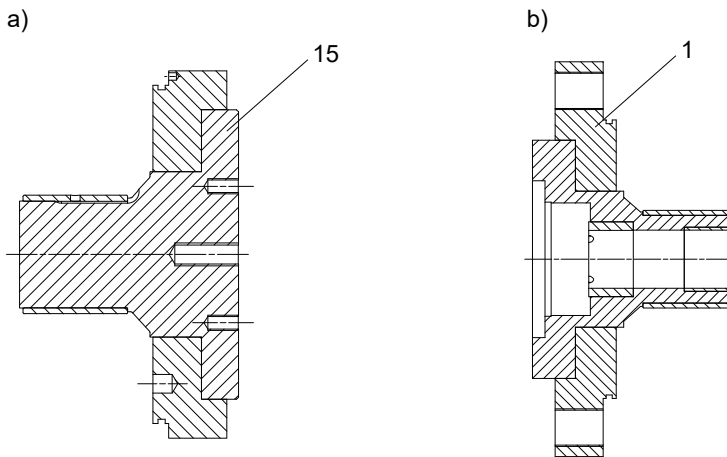

Detailed view: a) end cover b) Pump flange

List of components

Part No.	Description	Part No.	Description
7	Casing	30	Bush
130	Casing part	25	Bearing bush
32	Control cam	10	Guide plate
1	Adapter	34	Disc
15	Casing cover	31	Parallel pin
25	Thrust plate	20	Cylinder
16	Shaft	23/38/27/	Piston slipper and backing ring
29	Drive shaft	14	Thrust washer
26	Thrust bearing plate	36	Tie bolt
39/40	O-rings	19	Hexagon socket head cap screw
17	Mechanical seal	43	Bolt
19	Seal cover	12/33/11	Pin
10	Backing ring	41	Key
37	Ring	37	Spring
28	Retaining ring		



Salinnova GmbH
67240 Bobenheim-Roxheim • Gutenberg Straße 29
Tel. +49 6239 99391 - 11 • Fax +49 6239 99391 - 99
www.salinnova.com