

FAMCO
هایپر صنعت



water passion

تهران، کیلومتر ۲۱ بزرگراه لشگری (جاده مخصوص کرج)، روبروی پالایشگاه نفت پارس، پلاک ۱۲

Fax: ۰۲۱ - ۴۴۹۹۴۶۴۲ Tel: ۰۲۱ - ۴۸۰۰۰۰۴۹

E-mail: info@famcocorp.com

1959

WHO WE ARE

WE WANT TO CONTINUE THAT WHICH WAS STARTED MANY YEARS AGO BY VINICIO METTIFOGO, FOUNDER AND PIONEER.

Calpeda is a family owned company with an history of 61 years.

Today, we are a reality that has evolved over the years, always looking to the future with a spirit that has brought us to being a respected reference point in the great world of water.

Our history has taken our tradition and strength to you, acknowledged for our professionalism, quality, reliability and service.

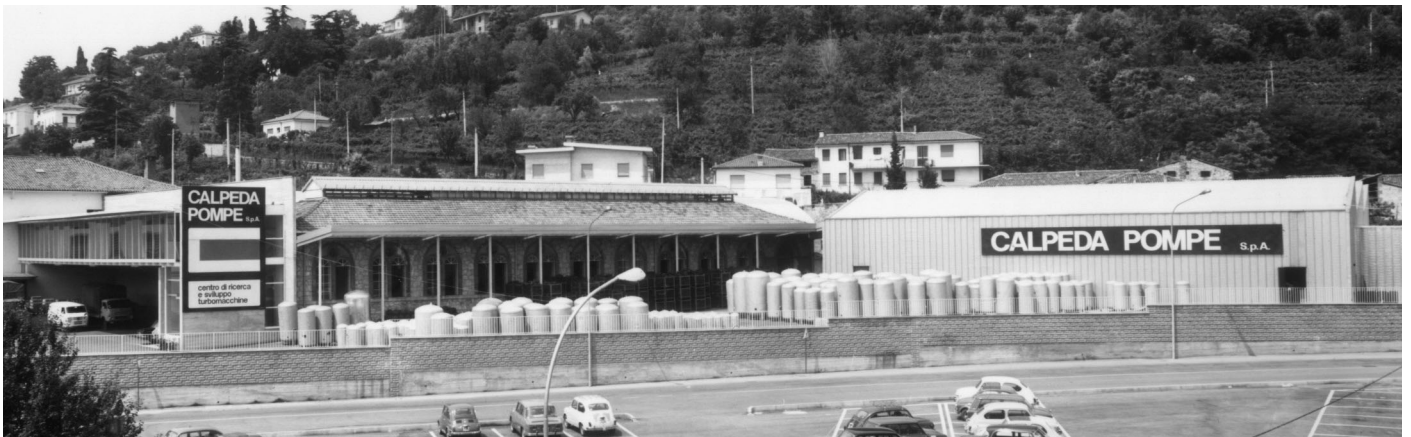

2020

CALPEDA TODAY

Employees: 250
Offices: Montorso V. (Vicenza) Italy
Main factory: 30,000 sq. metres (covered)
Types of pumps: more than 2,000
Power outputs: from 0.5 kW to 200 kW



NM, NMD

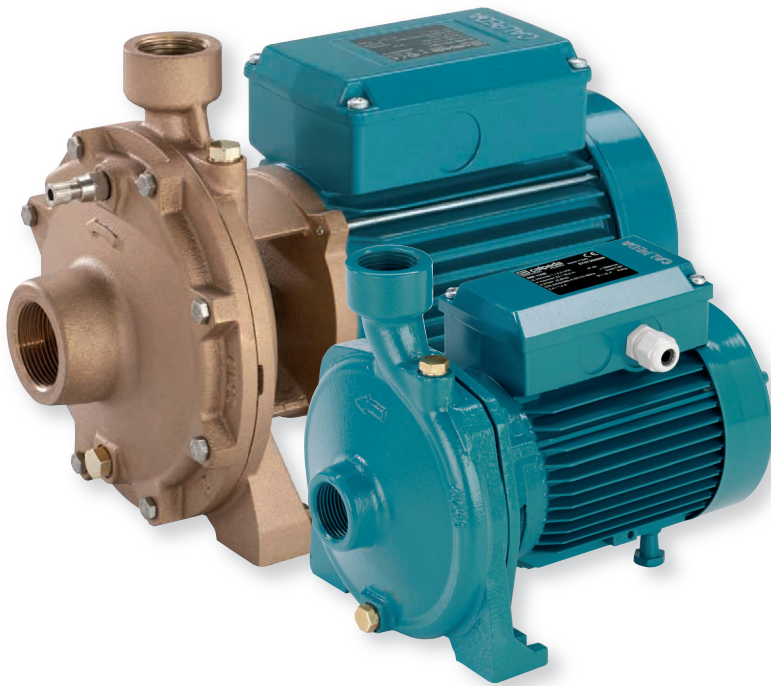

Construction

Close-coupled, centrifugal pumps; electric motor with extended shaft directly connected to the pump.

NM: single-impeller

NMD: with two back-to-back impellers (with axial thrust balancing).

Connections: threaded ports ISO 228/1 (BS 2779).

NM, NMD: version with pump casing and lantern bracket in cast iron.

B-NM, B-NMD: version with pump casing and lantern bracket in bronze (the pumps are supplied fully painted).

Applications

For clean liquids without abrasives, which are non-aggressive for the pump materials (solids content up to 0.2%).

For water supply.

For heating, air-conditioning, cooling and circulation plants.

For civil and industrial applications.

For fire fighting applications. For irrigation.

Operating conditions

Liquid temperature from -10 °C to +90 °C.

Ambient temperature up to 40° C.

Total suction lift up to 7 m.

Maximum permissible working pressure up to 10 bar

(16 bar for pumps NMD 25/190; NMD 32/210; NMD 40/180).

Continuous duty.

Motor

2-pole induction motor, 50 Hz ($n \approx 2900$ rpm).

NM, NMD: three-phase 230/400 V $\pm 10\%$ up to 3 kW;

400/690 V $\pm 10\%$ from 4 to 9,2 kW;

NMM, NMDM: single-phase 230 V $\pm 10\%$, with thermal protector.

Insulation class F. Protection IP 54.

Motor suitable for operation with frequency converter from 1,1 kW.

Classification scheme IE3 for three-phase motors from 0,75 kW.

Constructed in accordance with EN 60034-1; EN 60034-30-1.

EN 60335-1, EN 60335-2-41.

Special features on request

- Other voltages. - Frequency 60 Hz (as per 60 Hz data sheet).

- Protection IP 55. - Special mechanical seal

- Higher or lower liquid or ambient temperatures.

- Motor suitable for operation with frequency converter up to 0,75 kW.

The electropumps NM, B-NM series comply with the European Regulation no. 547/2012.

Materials

Components	NM, NMD	B-NM, B-NMD
Pump casing	Cast iron	Bronze
Lantern bracket	GJL 200 EN 1561	G-Cu Sn 10 EN 1982
Impeller	Brass P- Cu Zn 40 Pb 2 UNI 5705	
NM 17	Cast iron GJL 200 EN 1561	Bronze G-Cu Sn 10 EN 1982
Shaft	Cr steel AISI 430 Cr Ni steel AISI 303 1,1 -1,5 - 2,2 kW	Cr Ni Mo steel AISI 316
NM 6	Cr steel AISI 430	
Mechanical seal	Carbon - Ceramic - NBR	

Coverage chart $n \approx 2900$ rpm

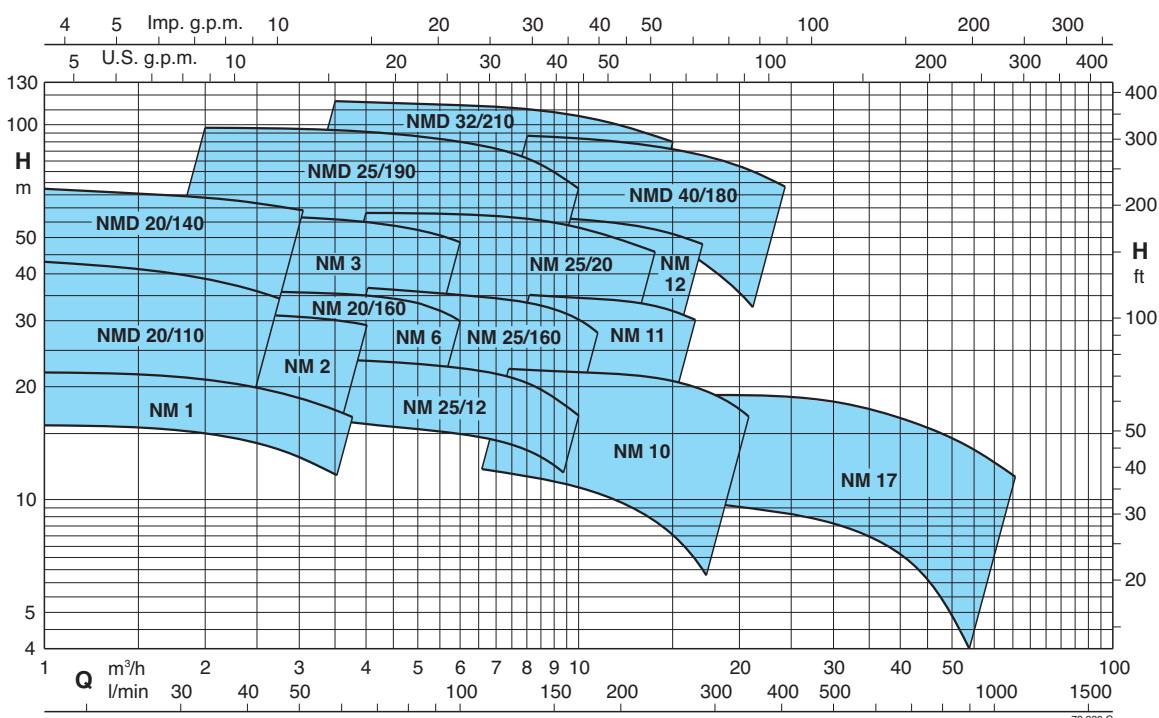

Performance n ≈ 2900 rpm

	NM	P ₂		Q m ³ /h l/min	Q															
		kW	HP		1 1,2 1,5 1,89 2,4 3 3,6 4,2 4,8 5,4 6 6,6 7,5 8,4															
					16 20 25 31,5 40 50 60 70 80 90 100 110 125 140															
	NM 1/AE●	0,37	0,5	H m	22	21,6	21,3	20,9	20,3	19,4	18,1	16,3								
	NM 2/B/A●	0,55	0,75		27	26,5	26	25,5	25	24	23	22	20							
	NM 2/S/A●	0,55	0,75		31	30,5	30	29	27,5	25,5	23,5	20	16							
	NM 2/A/B●	0,75	1		33,5	33	32,5	32	31,5	30,5	29,5	28,5	27	26	24					
	NM 6/B●	0,75	1					30,5	30	29,5	28,5	27,5	26,5	25,5	24	22	18			
	NM 6/A●	1,1	1,5					35,5	35,2	34,7	34	33	32	30,5	29	27	23,5	19*		
	NMM 3/CE	1,1	1,5			37,5	37,5	37	36,5	36	35	34	32							
	NM 3/C/A	1,1	1,5			37,5	37,5	37	36,5	36	35	34	32	30,5	28,5					
	NMM 3/BE	1,5	2			42	42	41,5	41	40,5	40	39	37	35	32					
	NM 3/B/A	1,5	2			47	47	46,5	46	45,5	45	44	43	41,5	40	37,5	33	26		
	NMM 3/A/A	1,8	2,5			47,5	47,5	47	46,5	46	45,5	44,5	43,5	42	40,5	38	33,5	26,5		
	NM 3/A/B	2,2	3			56	55,5	55,5	55	54,5	53,5	52,5	51,5	50	48	46	42	36		

B-NM B-NMD	NM NMD	P ₂		Q m ³ /h l/min	Q															
		kW	HP		1 1,2 1,5 1,89 2,4 3 3,6 4,2 4,8 5,4 6 6,6 7,5 8,4															
					16 20 25 31,5 40 50 60 70 80 90 100 110 125 140															
B-NMD 20/110B/A●	NMD 20/110B/A●	0,45	0,6	H m	33	32	31	29	26,5	23	18									
B-NMD 20/110Z/A●	NMD 20/110Z/A●	0,55	0,75		37	36	35	33	30,5	27,5	23	18								
B-NMD 20/110A/B●	NMD 20/110A/B●	0,75	1		43	42	40,5	39	36,5	33	29	25								
B-NMD 20/140BE	NMD 20/140BE	1,1	1,5		52	51,5	51	50	48,5	47	45									
B-NMD 20/140B/A	NMD 20/140B/A	1,1	1,5		53	52,5	52	51	50	48	46	43,5	40							
B-NMD 20/140AE	NMD 20/140AE	1,5	2		57,5	57	56,5	55,5	54	51,5	49	46	43	40	36					
B-NMD 20/140A/A	NMD 20/140A/A	1,5	2		67	66,5	66	64,5	63	61,5	59	57	53,5	50	46					
B-NM 20/160BE●	NM 20/160BE●	0,75	1					30,5	30	29,5	28,5	27,5	26,5	25,5	24	22				
B-NM 20/160A/A●	NM 20/160A/A●	1,1	1,5					36	35,5	35	34,5	33,5	32	30,5	29	27				

B-NM B-NMD	NM NMD	P ₂		Q m ³ /h l/min	Q															
		kW	HP		2,4 3 3,6 4,8 6 6,6 7,5 8,4 9,6 10,8 12 13,2 15 16,8 18															
					40 50 60 80 100 110 125 140 160 180 200 220 250 280 300															
B-NM 25/12B/A●	NM 25/12B/A●	0,55	0,75	H m	20	19,9	19,8	19,3	18,5	18	17,3	16,3	15	13,2	11					
B-NM 25/12A/B●	NM 25/12A/B●	0,75	1		23,5	23,4	23,3	22,9	22,1	21,7	20,9	20	18,7	17,1	15,2					
B-NM 25/160B/A●	NM 25/160B/A●	1,1	1,5			31	30,7	30	28,5	28	27	26	23							
B-NM 25/160A/A●	NM 25/160A/A●	1,5	2			36,5	36,2	35,5	34,5	34	33,5	32,5	31	28,5	26					
B-NM 25/200B/C	NM 25/20B/C	2,2	3			42,2	41,9	41,4	40,7	40,2	39,7	39	37,9	36,7	35,2	33,4				
B-NM 25/200A/B	NM 25/20A/B	3	4			49,9	49,8	49,4	48,9	48,5	48,1	47,5	46,6	45,6	44,4	43	40,8	37,9		
B-NM 25/200S/C	NM 25/20S/C	4	5,5			57,4	57,3	57	56,8	56,5	56,2	55,8	55,1	54,3	53,2	52	49,9	47,2	44,9	
B-NMD 25/190C/B	NMD 25/190C/B	2,2	3			62	60,5	59	55,5	51	48,5	44	38							
B-NMD 25/190B/A	NMD 25/190B/A	3	4			76	75	74	70	66	64	60	54	46						
B-NMD 25/190A/B	NMD 25/190A/B	4	5,5			98	97	96	93,5	90	88	84	79	70						

	NM	P ₂		Q m ³ /h l/min	Q															
		kW	HP		6,6 7,5 8,4 9,6 10,8 12 13,2 15 16,8 18,9 21 24 27 30															
					110 125 140 160 180 200 220 250 280 315 350 400 450 500															
	NM 10/FE●	0,55	0,75	H m	12,5	12,5	12	11,5	11	10	9	7,5								
	NM 10/DE●	0,75	1		18	18	17,5	17	16,5	16	15,5	14								
	NM 10/A/A●	1,1	1,5		23	23	22,5	22	21,5	21	20,5	19								
	NM 10/S/A●	1,5	2		23,5	23,5	23	22,5	22	21,5	21	20,5	19	18,5	16,5	13				
	NMM 11/BE	1,5	2		26,5	25,5	25	24	23	22,5	21,5	19,5	17,5							
	NM 11/B/A	1,5	2		29,5	29,5	29	28,5	27,5	27	26	25*	22,5*							
	NMM 11/A	1,8	2,5		30,2	30,1	29,8	29,4	28,8	28,1	27,4	26	24,5							
	NM 11/A/B	2,2	3		35,5	35,5	35	34,5	34	33,5	33	32*	30*							
	NM 12/D/B	2,2	3		38	37,5	37	36	35	33,5	32									
	NM 12/C/A	3	4		45	44,5	44	43,5	42,5	41	40	38	36							
	NM 12/A/B	4	5,5		57,5	57	56	55,5	55	54,5	53,5	51,5	49							

Performance n ≈ 2900 rpm

B-NMD	NMD	P ₂		Q m ³ /h l/min	5,4	6	6,6	7,5	8,4	9,6	10,8	12	13,2	15	16,8	18,9	21	24		
		kW	HP		H m	90	100	110	125	140	160	180	200	220	250	280	315	350	400	
B-NMD 32/210D/B	NMD 32/210D/B	4	5,5	H m	71	69	67,5	65	62,5	58	53	46	37*							
B-NMD 32/210C/A	NMD 32/210C/A	5,5	7,5		84	83	82	81	79	76	73	69	64*	54*						
B-NMD 32/210B/A	NMD 32/210B/A	7,5	10		104	103	102	100	98	95	92	88	84*	76*						
B-NMD 32/210A/B	NMD 32/210A/B	9,2	12,5		114	113	112	110	108	105	103	99	96*	90*						
B-NMD 40/180D/B	NMD 40/180D/B	4	5,5					60	59,5	57	56	53	51,5	48	44	39	34*	25*		
B-NMD 40/180C/A	NMD 40/180C/A	5,5	7,5					69	68	67	66	64,5	63	60	57	53	48*	40*		
B-NMD 40/180B/A	NMD 40/180B/A	7,5	10					87	86	85	84	82,5	81	78	75	71	66*	59*		
B-NMD 40/180A/B	NMD 40/180A/B	9,2	12,5					94	93	92	91	89,5	88	85	82	78	74*	67*		

B-NM	NM	P ₂		Q m ³ /h l/min	21	24	27	30	33	37,8	42	48	54	60	66	75	84	96		
		kW	HP		H m	350	400	450	500	550	630	700	800	900	1000	1100	1250	1400	1600	
B-NM 17/H/A ●	NM 17/H/A ●	1,1	1,5	H m	9,5	9,2	9	8,6	8,2	7,5	6,7	5,5	3,5*							
B-NM 17/G/A ●	NM 17/G/A ●	1,5	2		12	11,7	11,5	11,2	11	10,3	9,7	8,5	7*	4*						
B-NM 17/F/B	NM 17/F/B	2,2	3			16	16	15,5	15	14,5	14	13	11,5*	10*	8*					
B-NM 17/D/A	NM 17/D/A	3	4					18	18	17,5	17	16,5	15,5	14*	13*	11,5*				

NM, NMD Standard construction.
B-NM, B-NMD Bronze construction.

P₂ Rated motor power output.
H Total head in m.

● With single-phase motor = NMM - NMDM.
* Maximum suction lift 1-2 m.
Tolerances according to UNI EN ISO 9906:2012

تهران، کیلومتر ۲۱ بزرگراه لشگری (جاده مخصوص کرج)، روبروی پالایشگاه نفت پارس، پلاک ۱۲
Tel: ۰۲۱ - ۴ ۸ ۰ ۰ ۰ ۰ ۴ ۹ Fax: ۰۲۱ - ۴ ۴ ۹ ۹ ۴ ۶ ۴ ۲

www.famcocorp.com

E-mail: info@famcocorp.com

Rated currents

	P ₁		P ₂		230 V 1~ IN A	IA/IN
	kW	HP	kW	HP		
	0,62	0,37	0,5	0,5	3	2,7
	0,72	0,45	0,6	0,6	3,6	2,9
	1	0,55	0,75	0,75	4,5	2,3
* NMM 25/12B/A	0,9	0,55	0,75	0,75	4,2	2,5
* NMM 10/FE	0,9	0,55	0,75	0,75	4,2	2,5
	1,3	0,75	1	1	6	3
* NMM 25/12A/A	1,2	0,75	1	1	5,4	3,3
* NMM 10/DE	1,2	0,75	1	1	5,8	2,6
	1,6	1,1	1,5	1,5	7,4	3
	2	1,5	2	2	9,2	3,8
	2,5	1,8	2,5	2,5	11,2	4,5

	P ₂		230 V Δ / 400 V Y 400 V Δ / 690 V Y			IA/IN
	kW	HP	IN A	IN A	IN A	
	0,37	0,5	2,3	1,3		3,8
	0,45	0,6	2,3	1,3		3,5
	0,55	0,75	3	1,7		3,6
* NM 25/12B/A	0,55	0,75	2,8	1,6		3,9
* NM 10/FE	0,55	0,75	4	2,3		4,8
	0,75	1	3,7	2,2		5,5
* NM 25/12A/B	0,75	1	3,5	2		6,1
* NM 10/DE	0,75	1	4	2,3		6,1
	1,1	1,5	4,6	2,7		5,5
	1,5	2	7,5	4,3		6,1
	2,2	3	9,15	5,3		8,4
	3	4	11,5	6,6		8,2
	4	5,5		9,6	5,5	8,9
	5,5	7,5		10,9	6,3	9,1
	7,5	10		14,3	8,3	9,1
	9,2	12,5		18,5	10,7	8,2

P₁ Maximum power input.
P₂ Rated motor power output.
IA/IN D.O.L. starting current / Nominal current

Characteristic curves $n \approx 2900$ rpm

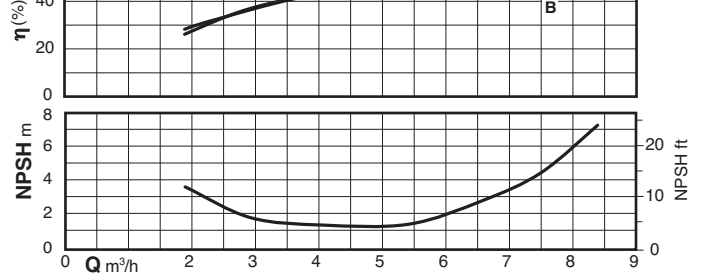
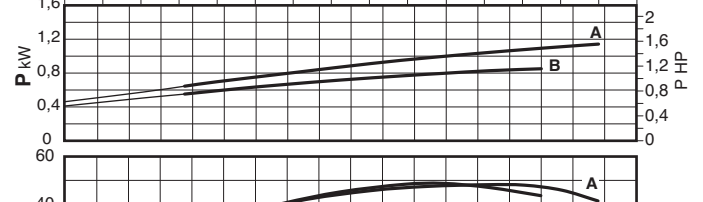
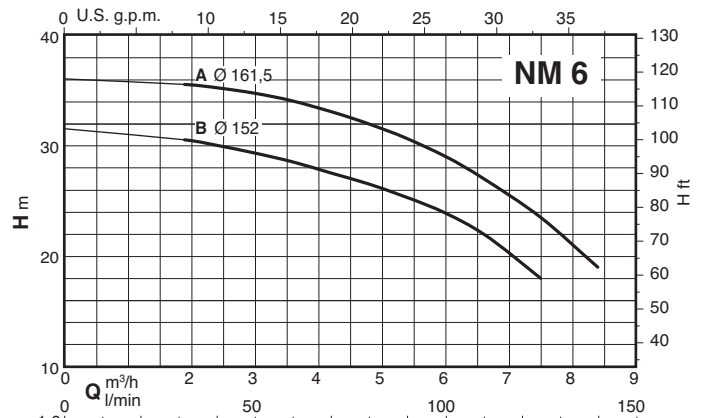
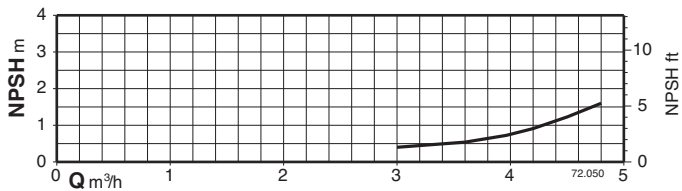
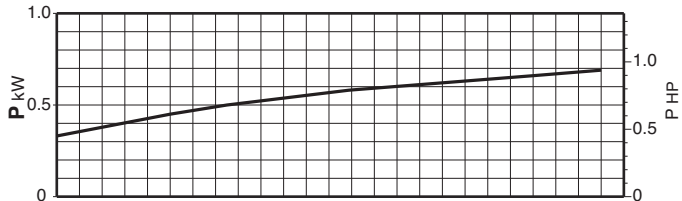
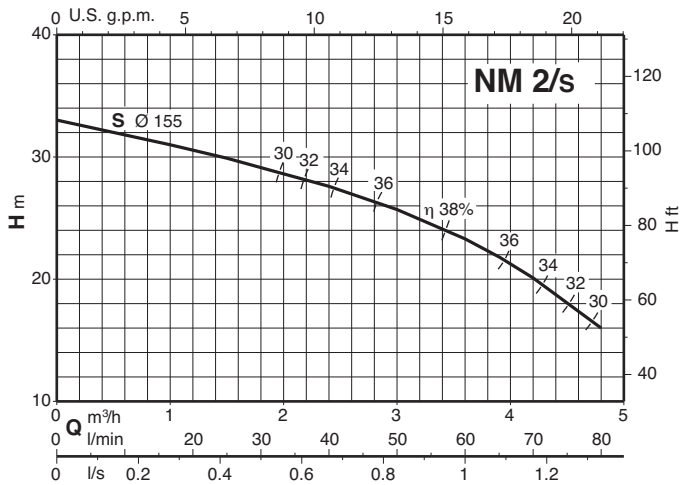
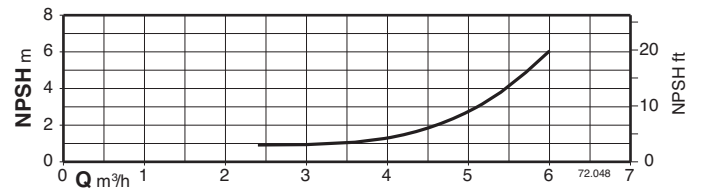
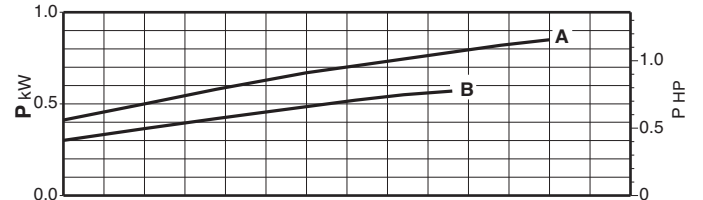
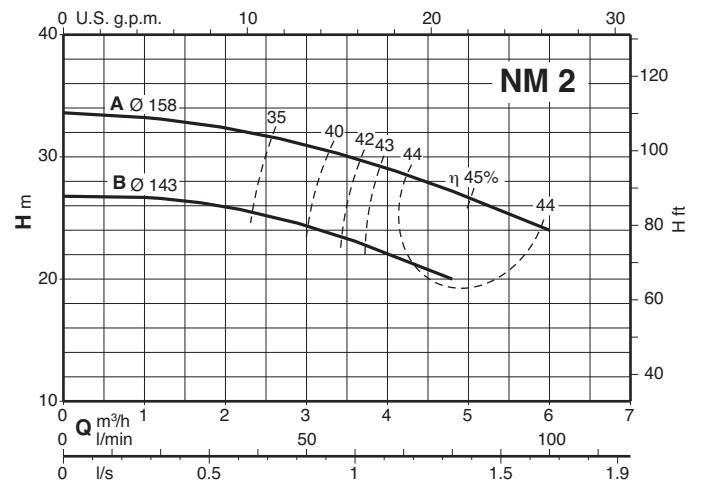
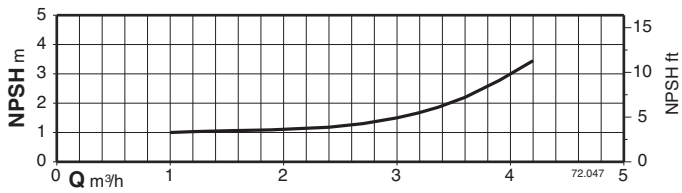
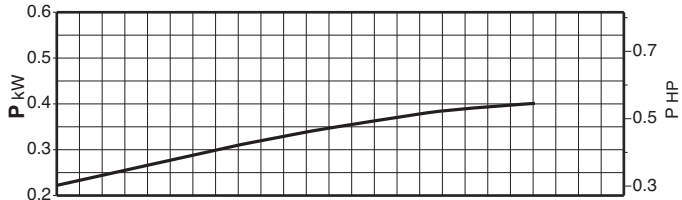
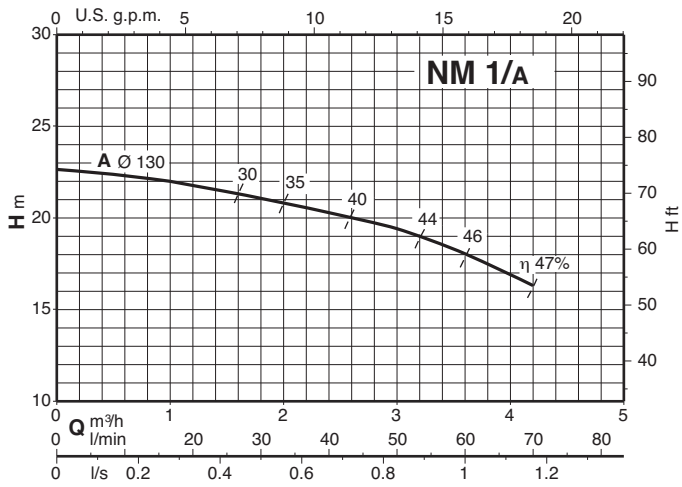

Characteristic curves $n \approx 2900$ rpm

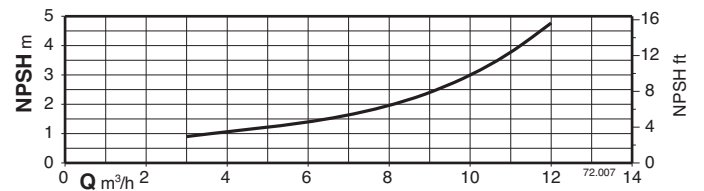
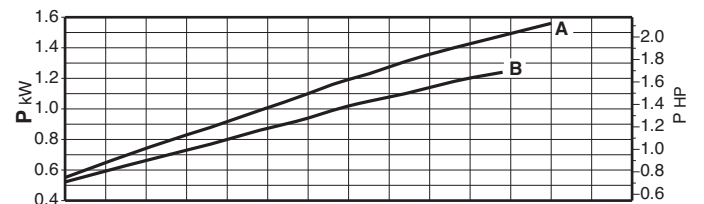
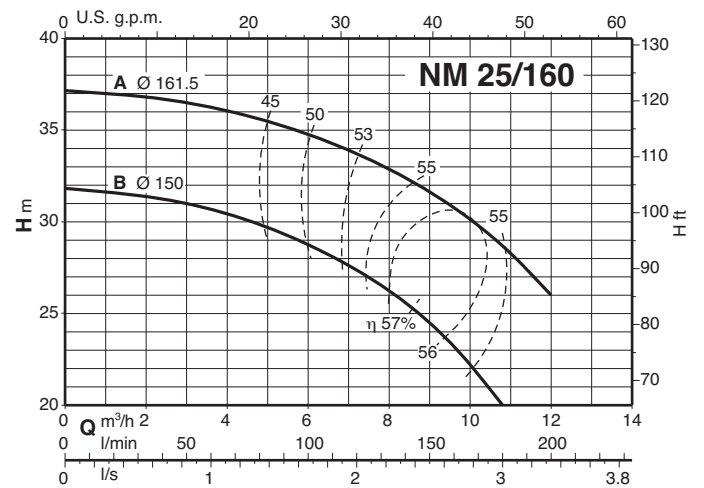
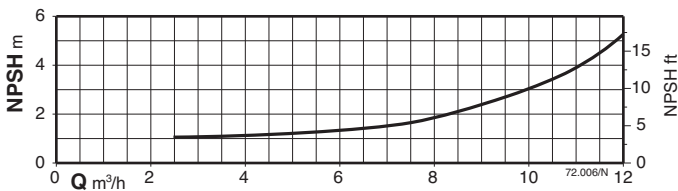
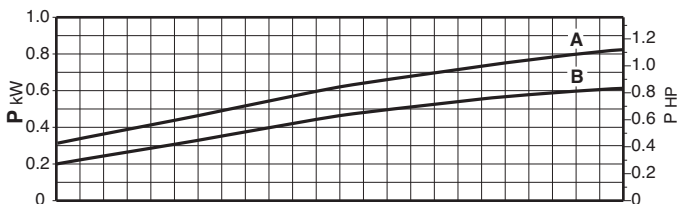
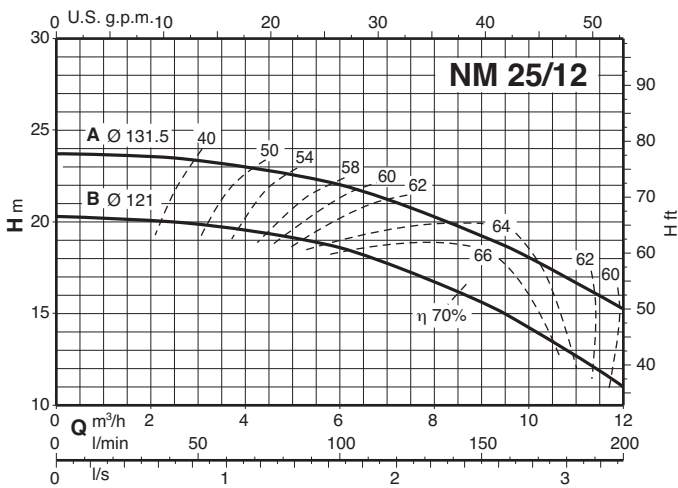
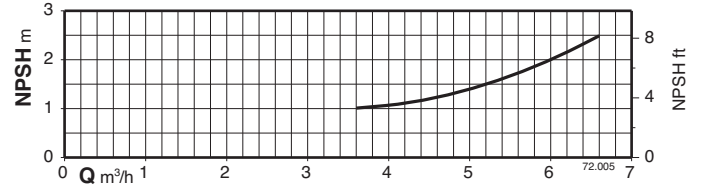
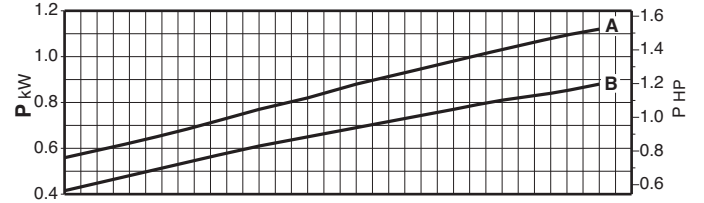
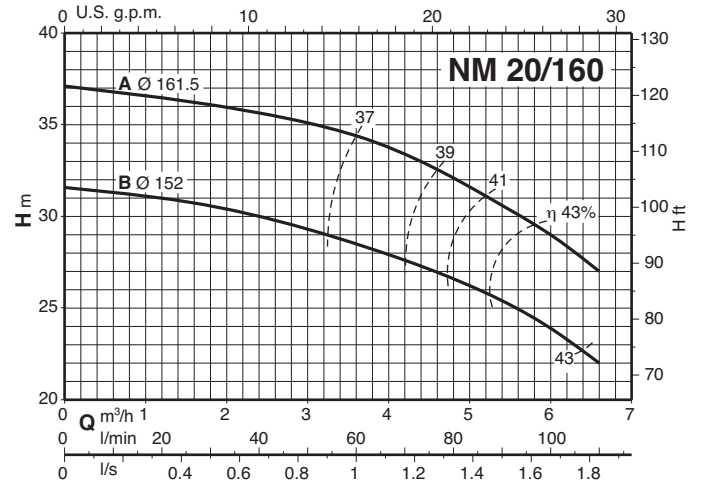
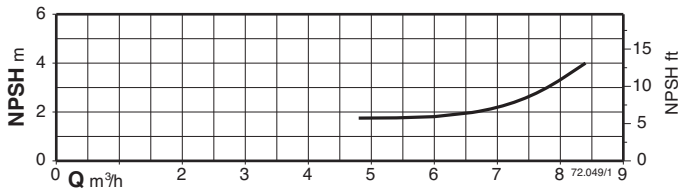
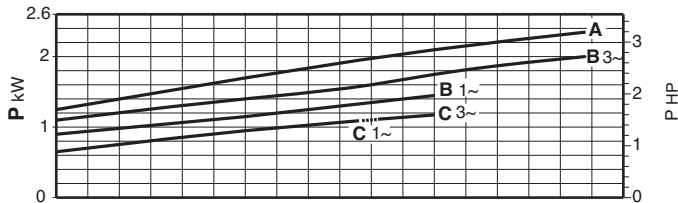
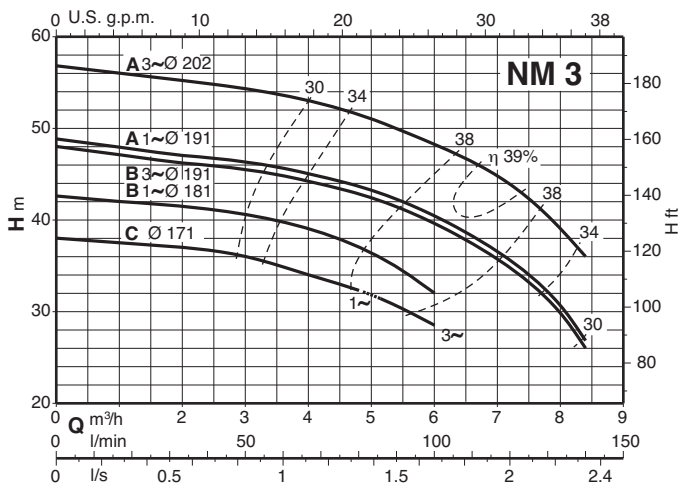

Characteristic curves $n \approx 2900$ rpm

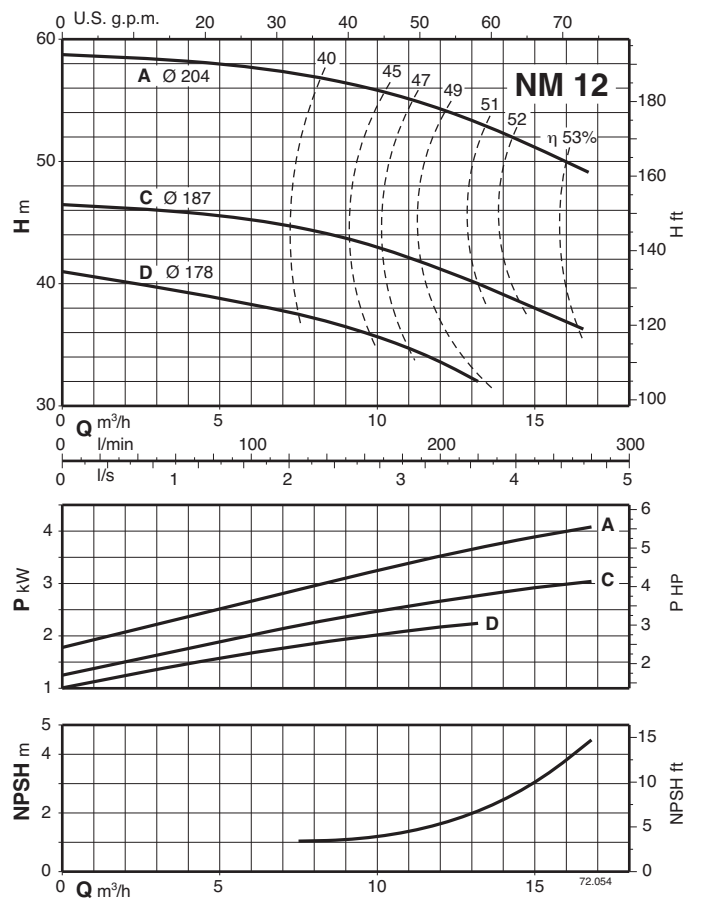
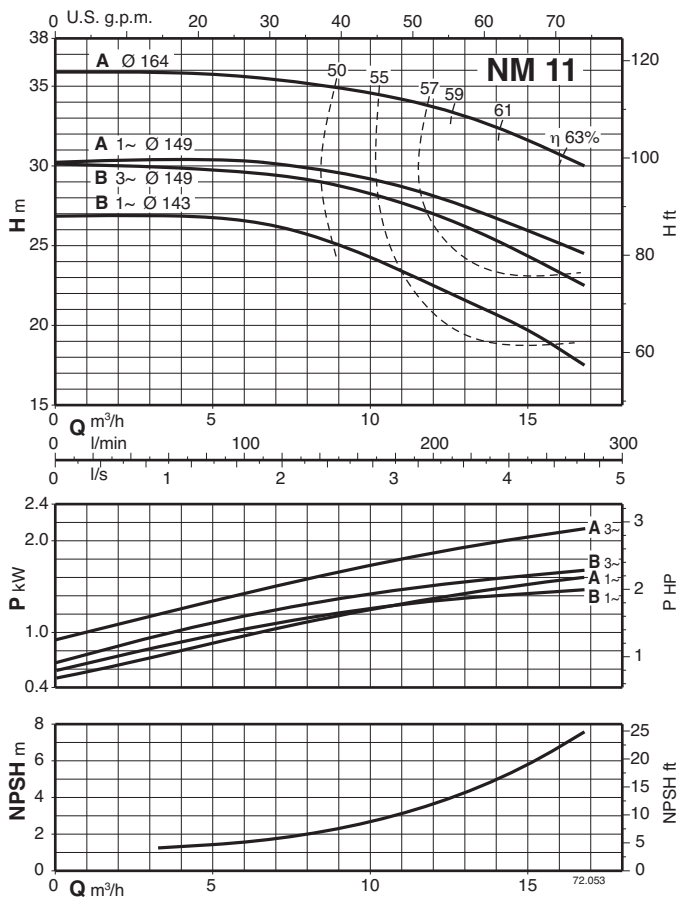
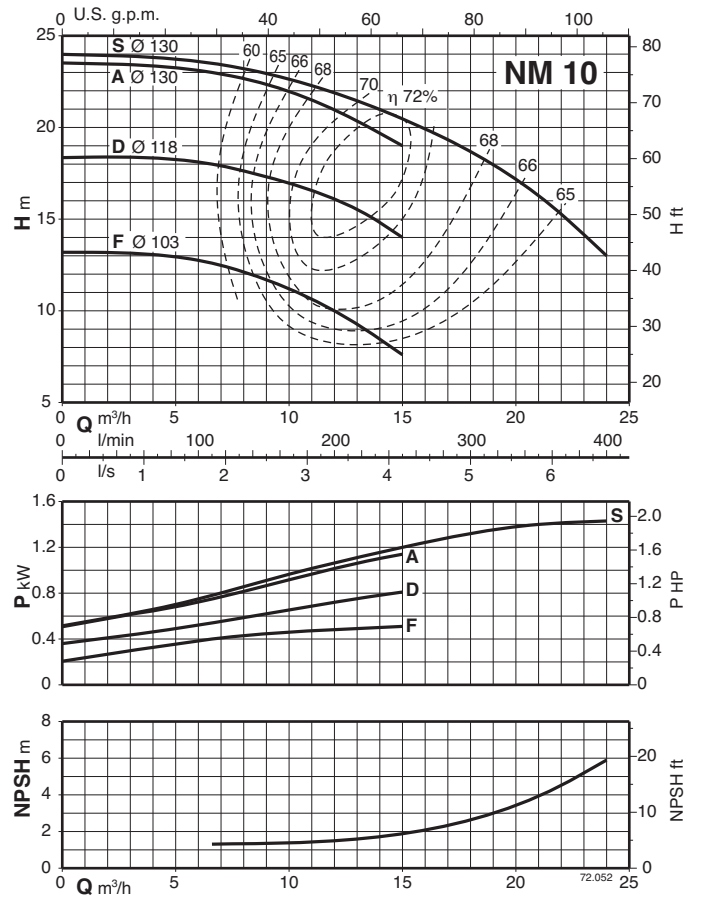
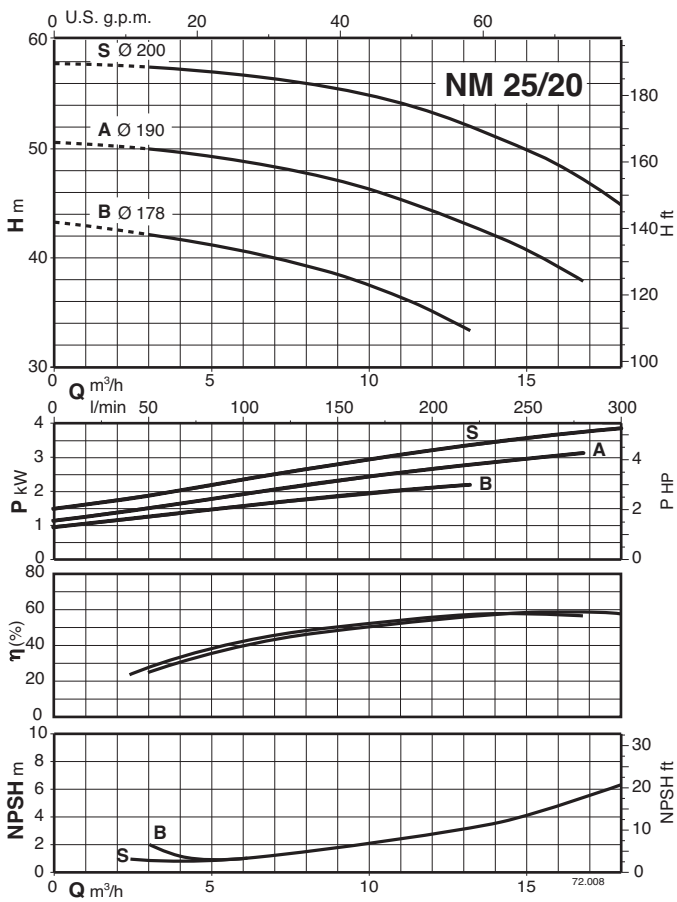

Characteristic curves $n \approx 2900$ rpm

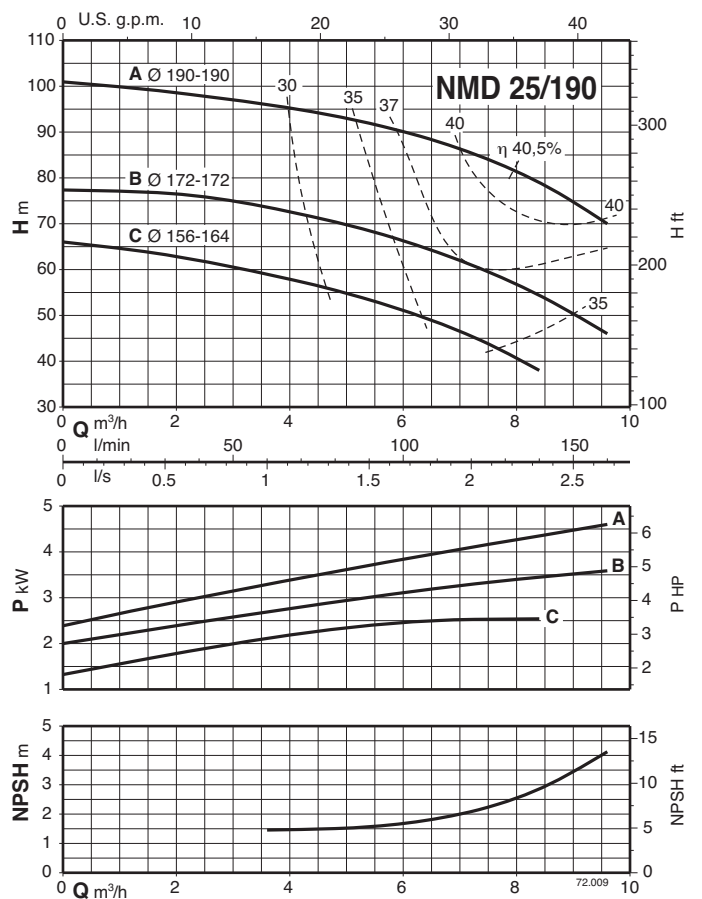
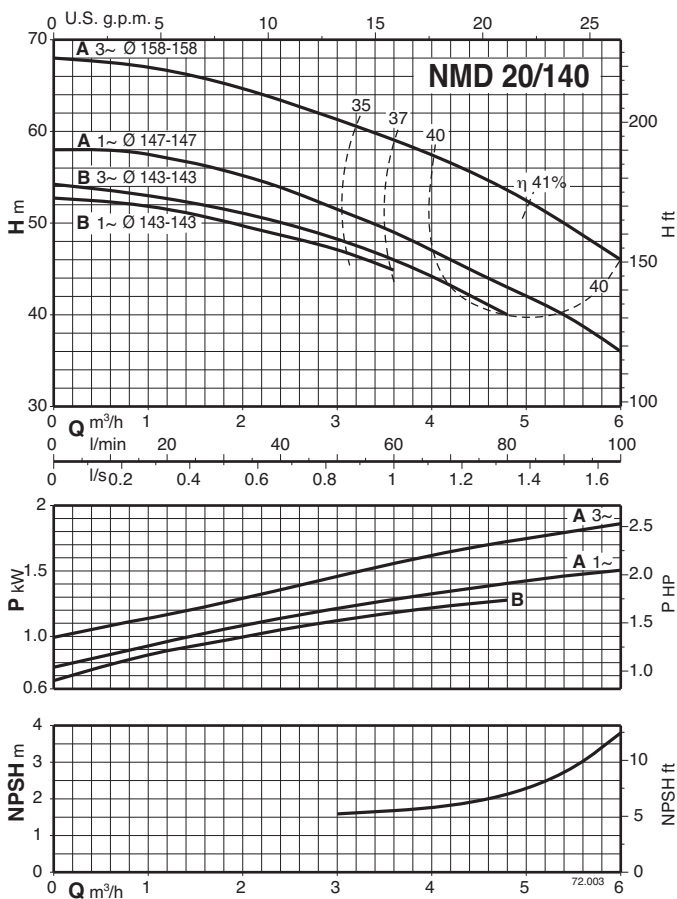
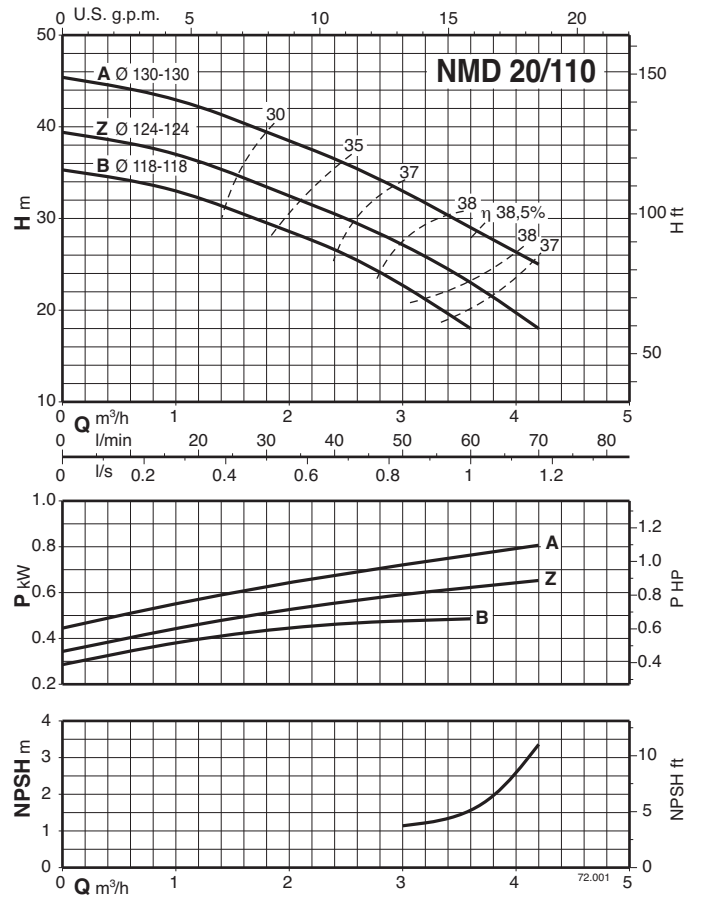
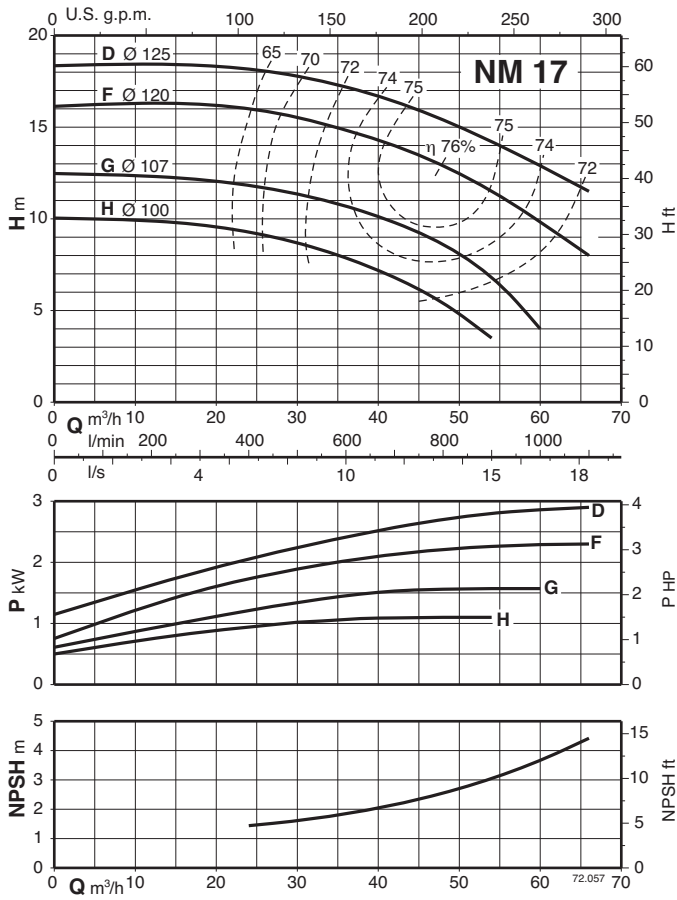

Characteristic curves $n \approx 2900$ rpm

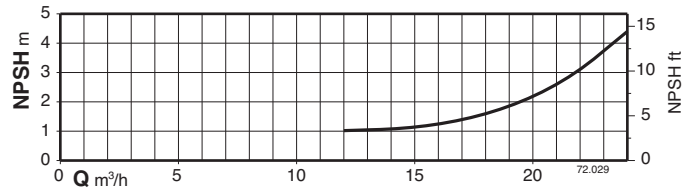
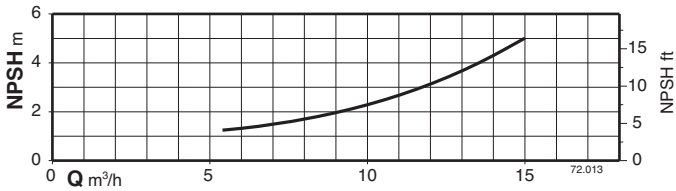
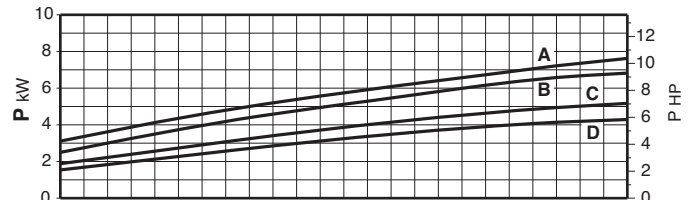
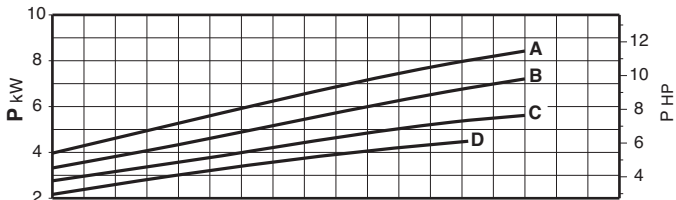
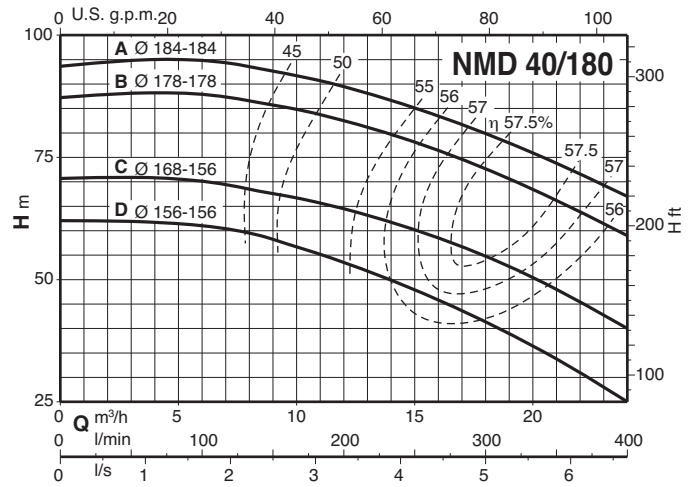
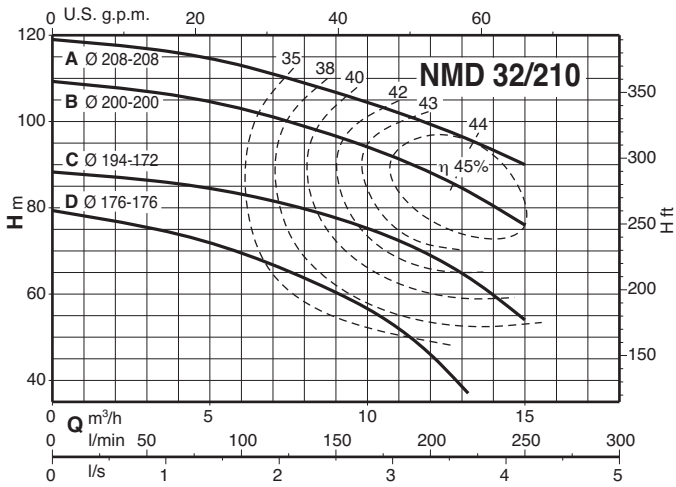

Dimensions and weights

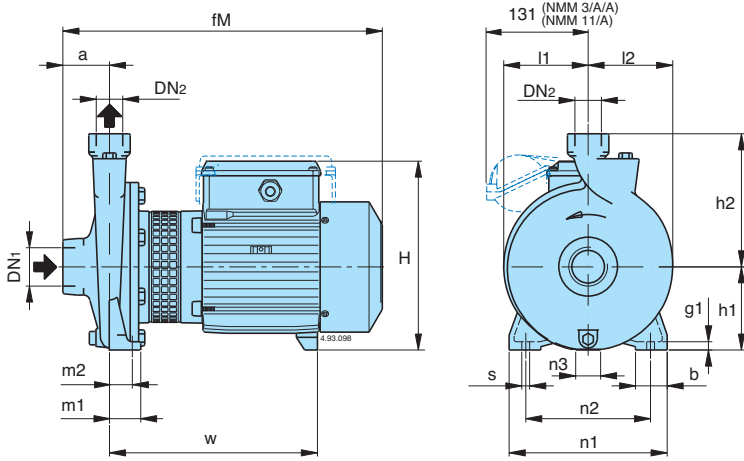

TYPE	NMM kg	NM kg	B-NM kg
NM 1/AE	8,7	8,6	
NM 2/B/A	14	13,1	
NM 2/S/A	14,2	13,3	
NM 2/A/B	15,1	15	
NM 6/B	17,8	17,6	
NM 6/A	19,3	19	
NM 3/C/A	24	22,9	
NM 3/B/A	26	25,1	
NM 3/A/B	30,4	29,1	
B- NM 20/160BE	19,9	18,4	21
B- NM 20/160A/A	20,7	19,7	22,5
B- NM 25/12B/A	13,2	12,3	13,5
B- NM 25/12A/B	14,2	14,1	15,3
B- NM 25/160B/A	20,4	19,7	22,8
B- NM 25/160A/A	22,5	21,5	24
NM 25/20B/C		31,6	
NM 25/20A/B		40,9	
NM 25/20S/C		42,2	
B- NM 25/200B/C			35,7
B- NM 25/200A/C			43,7
B- NM 25/200S/C			45,2
NM 10/FE	19,3	18,5	
NM 10/DE	19,4	18,8	
NM 10/A/A	20,2	19,3	
NM 10/S/A	22,1	21,5	
NM 11/B/A	24,7	24,1	
NM 11/A/B		28,1	
NM 12/D/B		33,5	
NM 12/C/A		42	
NM 12/A/B		43,5	
B- NM 17/H/A	23	22,2	29,2
B- NM 17/G/A	24,2	23,2	30,2
B- NM 17/F/B		28,2	35,2
B- NM 17/D/A		36,2	43,2

B-NM	NM	DN1 ISO 228	DN2 ISO 228	mm															
				a	fM	h1	h2	H	m1	m2	n1	n2	n3	b	s	l1	l2	w	g1
	NM 1/AE	G 1	G 1	40	261	80	132	176	40	32	170	140	17	35	9,5	77	81	171	10
	NM 2/A/B-S/A-B/A	G 1	G 1	45	305	95	150	207	40	32	190	160	17	35	9,5	87	90	203	10
	NM 6/A-B	G 1 1/4	G 1	53	349	100	150	213	37,5	27,5	190	150	17	38	9,5	102	102	225	10
	NM 3/B/A-C/A	G 1	G 1	50	375	112	180	240	55	43	245	205	37	45	11,5	110	113	244	12
	NM 3/A/B	G 1	G 1	50	415	112	180	240	55	43	245	205	37	45	11,5	110	113	284	12
	B- NM 20/160A/A-BE	G 1 1/4	G 3/4	53	375	100	150	228	37,5	27,5	190	150	30	38	9,5	102	102	246	10
	NM 20/160A/A-BE	G 1 1/4	G 3/4	53	375	100	150	228	37,5	27,5	190	150	30	38	9,5	102	102	246	10
	B- NM 25/12A/B-B/A	G 1 1/2	G 1	56	313	90	140	199	37,5	27,5	170	130	9	38	9,5	85	88	195	10
	NM 25/12A/B-B/A	G 1 1/2	G 1	56	313	90	140	199	37,5	27,5	170	130	9	38	9,5	85	88	195	10
	B- NM 25/160A/A-B/A	G 1 1/2	G 1	56	380	100	160	228	37,5	27,5	190	150	30	38	9,5	102	102	246	10
	NM 25/160A/A-B/A	G 1 1/2	G 1	56	380	100	160	228	37,5	27,5	190	150	30	38	9,5	102	102	246	10
	NM 25/20B/C	G 1 1/2	G 1	63	433	125	180	253	45	32,5	245	200	49	45	11,5	125	125	291	11
	NM 25/20A/B-S/C	G 1 1/2	G 1	63	460	125	180	263	45	32,5	245	200	42	45	11,5	125	125	295	11
	B- NM 25/200B/C	G 1 1/2	G 1	63	445	125	180	253	45	32,5	245	200	49	45	11,5	125	125	303	11
	NM 25/200A/B-S/C	G 1 1/2	G 1	63	460	125	180	263	45	32,5	245	200	42	45	11,5	125	125	295	11
	NM 10/S/A-A/A-DE-FE	G 2	G 1 1/4	63	382	100	150	228	50	35	190	140	30	50	13	90	97	239	14
	NM 11/B/A	G 2	G 1 1/4	70	400	112	170	240	50	35	210	160	37	50	15	103	110	247	14
	NM 11/A/B	G 2	G 1 1/4	70	440	112	170	240	50	35	210	160	37	50	15	103	110	287	14
	NM 12/D/B	G 2	G 1 1/4	70	440	132	190	260	50	35	240	190	47	50	15	125	127	287	14
	NM 12/A/B-C/A	G 2	G 1 1/4	70	470	132	190	270	50	35	240	190	45	50	15	125	127	300	14
	B- NM 17/G/A-H/A	G 2 1/2	G 2 1/2	80	417	112	160	240	50	35	210	160	37	50	14	96	113	257	14
	NM 17/G/A-H/A	G 2 1/2	G 2 1/2	80	417	112	160	240	50	35	210	160	37	50	14	96	113	257	14
	B- NM 17/F/B	G 2 1/2	G 2 1/2	80	463	112	160	240	50	35	210	160	37	50	14	96	113	304	14
	NM 17/F/B	G 2 1/2	G 2 1/2	80	463	112	160	240	50	35	210	160	37	50	14	96	113	304	14
	B- NM 17/D/A	G 2 1/2	G 2 1/2	80	480	112	160	250	50	35	210	160	20	50	14	96	113	295	14
	NM 17/D/A	G 2 1/2	G 2 1/2	80	480	112	160	250	50	35	210	160	20	50	14	96	113	295	14

Dimensions and weights

NMD 20/110

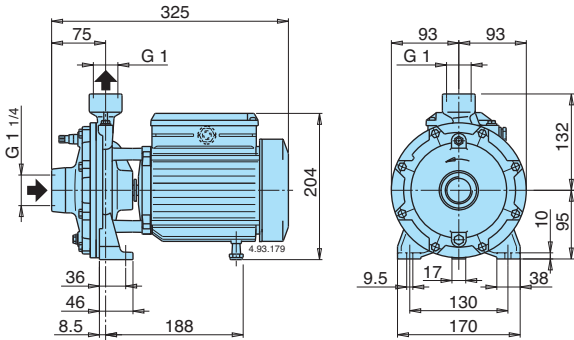

TYPE	NMDM kg	NMD kg	B-NMD kg
B- NMD 20/110B/A	13	12,1	13,4
B- NMD 20/110Z/A	14	13	14,2
B- NMD 20/110A/B	15,1	14,2	17,4

NMD 20/140 NMD 25/190

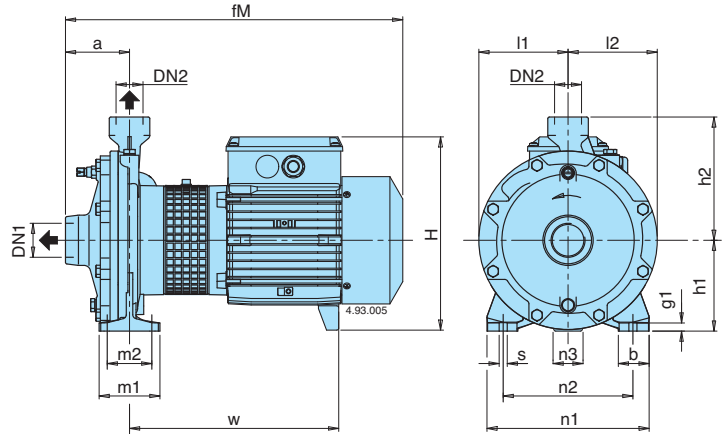

TYPE	NMDM kg	NMD kg	B-NMD kg
B- NMD 20/140B/A	23,9	22,7	25,2
B- NMD 20/140A/A	25,2	24,8	27,6
B- NMD 25/190C/B		42	45,7
B- NMD 25/190B/A		49,7	54
B- NMD 25/190A/B		51,5	55,5

B-NMD	NMD	DN1 ISO 228	DN2 ISO 228	mm															
				a	fm	h1	h2	H	m1	m2	n1	n2	n3	b	s	l1	l2	w	g1
B- NMD 20/140A/A-B/A	NMD 20/140A/A-B/A	G 1 1/4	G 1	80	417	112	152	243	75	55	200	160	37	38	9,5	110	110	256	10
B- NMD 25/190C/B	NMD 25/190C/B	G 1 1/2	G 1	97	487	140	180	268	100	70	240	190	50	50	14	133	133	314	13
B- NMD 25/190A/B-B/B	NMD 25/190A/B-B/A				500			278					49					306	

NMD 32/210 NMD 40/180

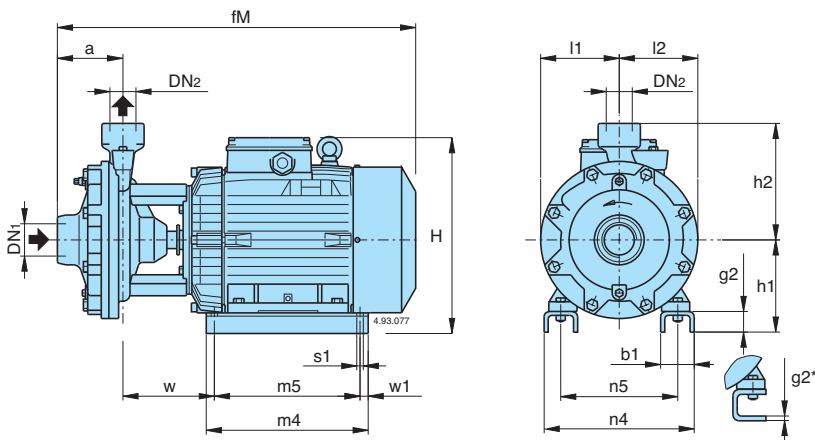

TYPE	NMD kg	B-NMD kg
B- NMD 32/210D/B	60,5	66,5
B- NMD 32/210C/A	71	77
B- NMD 32/210B/A	77	82,5
B- NMD 32/210A/B	99	105
B- NMD 40/180D/B	59,5	65,5
B- NMD 40/180C/A	70	76
B- NMD 40/180B/A	76	81,5
B- NMD 40/180A/B	97	102

B-NMD	NMD	DN1 ISO 228	DN2 ISO 228	mm																
				a	fm	h1	h2	H	m4	m5	n4	n5	w1	b1	s1	l1	l2	w	g2	
B- NMD 32/210D/B	NMD 32/210D/B	G 2	G 1 1/4	110	530	155	215	293	205	175	194	140		54	10		150	150	139	6*
B- NMD 32/210B/A -C/A	NMD 32/210B/A -C/A				550	150	215	310	280	250	258	190	15	68	12				108	38
B- NMD 32/210A/B	NMD 32/210A/B				625	170		355	298	268	286	216		70	12				152	38
B- NMD 40/180D/B	NMD 40/180D/B	G 2	G 1 1/2	121	535	155	215	293	205	175	194	140		54	10		145	145	133	6*
B- NMD 40/180B/A -C/A	NMD 40/180B/A -C/A				555	150	215	310	280	250	258	190	15	68	12				102	38
B- NMD 40/180A/B	NMD 40/180A/B				630	170		355	298	268	286	216		70	12				145	38

Features

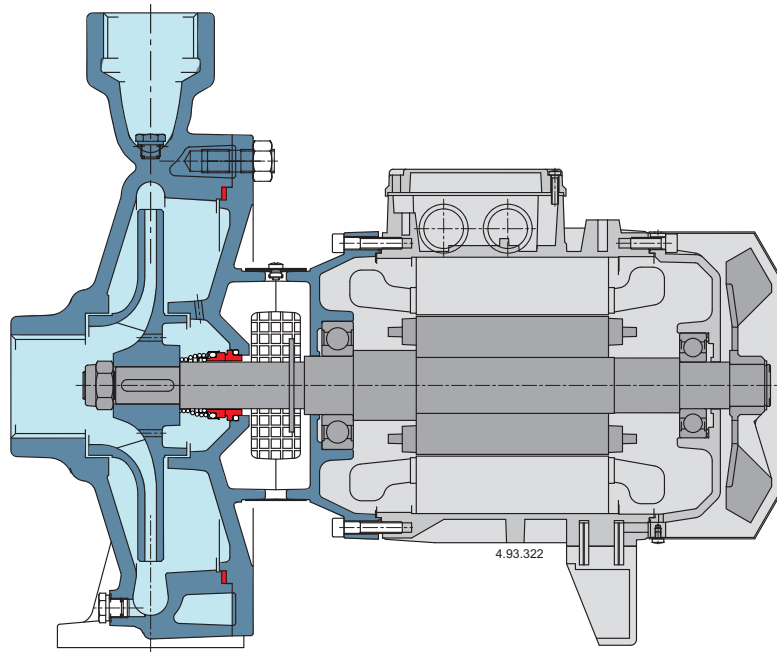

Compact Design

The compact design allows for easy installation even in confined spaces.

Robust

The mechanical structure of the hydraulic parts in contact with the pumped liquid are dimensioned to guarantee the maximum resistance to mechanical stress.

A unique design

The lantern bracket design prevents contact with the pumps rotating parts, providing protection to the end user whilst allowing for inspection of the mechanical seal.

Reliable

The bearing and shaft are designed to ensure the reduction of the stress, providing high reliability under all operating conditions.

Features

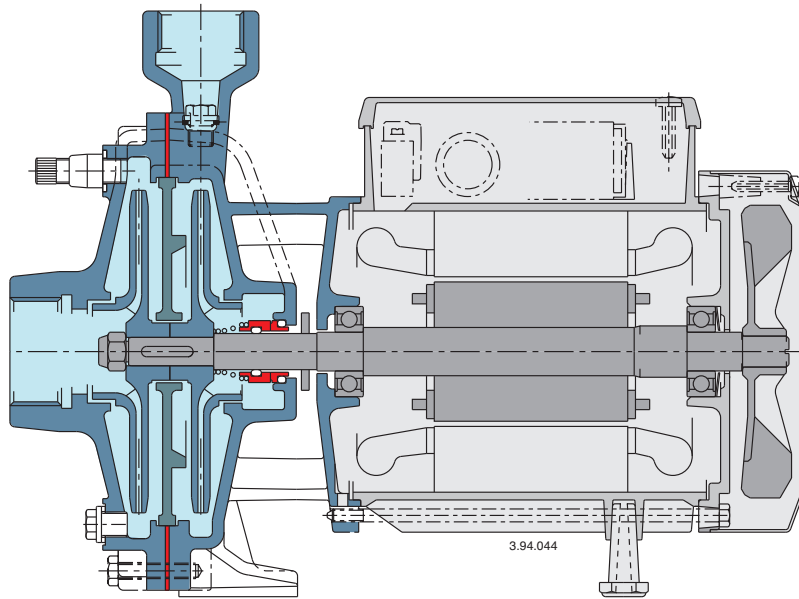
**Flexible**

The option to choose between cast iron and bronze materials for the hydraulic parts in contact with the pumped liquid allows NMD series pumps to be selected for use with different types of liquids.

Robust

The mechanical structure of the hydraulic parts in contact with the pumped liquid are dimensioned to guarantee the maximum resistance to mechanical stress.

Reliable

The bearing and shaft are designed to ensure the reduction of the stress, providing high reliability under all operating conditions.

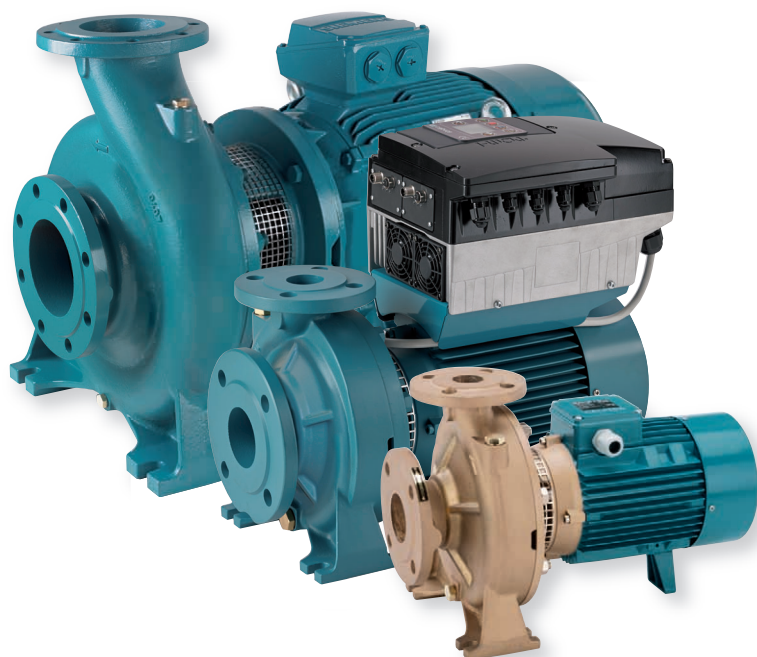

The electropumps NM, B-NM, NMS, B-NMS series comply with the European Regulation no. 547/2012.

Materials

Components	NM, NMS	B-NM, B-NMS
Pump casing	Cast iron	Bronze
Lantern bracket NM	GJL 200 EN 1561	G-Cu Sn 10 EN 1982
Casing cover for NMS		
Lantern bracket NMS	Cast iron GJL 200 EN 1561	
Impeller	Cast iron	Bronze
	GJL 200 EN 1561	G-Cu Sn 10 EN 1982
	Brass P- Cu Zn 40 Pb 2 UNI 5705 for 32/12, 32/16, 32/20, 32L/20, 40/20	
Shaft	Cr-Ni steel AISI 303	Cr Ni Mo steel
	AISI 430 from 3 kW to 22 kW	AISI 316
Mechanical seal	Carbon - Ceramic - NBR	
Counter-flanges	Steel Fe 430B UNI 7070	

Construction

Close-coupled centrifugal pumps; electric motor with extended shaft directly connected to the pump up to 22 kW, new bracket construction for standard motors (stub-shaft construction) from 30 to 75 kW with integrated thrust bearing.

Pump casing with axial suction and radial delivery on top, main dimensions and performance according to EN 733.

NM(S): version with pump casing and lantern bracket in cast iron. B-NM(S): version with pump casing and lantern bracket/casing cover in bronze. (the pumps are supplied fully painted).

Connections: Flanges according to PN 10, EN 1092-2.

Counter-flanges (on request)

Sizes	Flanges
from NM 32/.. to NM 50/...	Screwed flanges EN 1092-1, PN 16
from NM 65/.. to NMS 100/...	Flanges for welding EN 1092-1, PN 10

Version with frequency converter (on request)

Applications

For clean liquids without abrasives, which are non-aggressive for the pump materials (solids content up to 0,2%). For water supply. For heating, air conditioning, cooling and circulation plants.

For civil and industrial applications.

For fire fighting applications. For irrigation.

Operating conditions

Liquid temperature from -10 °C to +90 °C.

Ambient temperature up to 40° C.

Total suction lift up to 7 m.

Maximum permissible working pressure up to 10 bar (16 bar for NM 32L/16,20; NM 40/16,20; NM 50/12,16; NM 65/12,16,20,25; NM 80/16; NM 100/20).

Continuous duty.

Motor

2-pole induction motor, 50 Hz (n ≈ 2900 rpm).

NM, NMS: three-phase 230/400 V ± 10% up to 3 kW; 400/690 V ± 10% from 4 to 75 kW.

Insulation class F. Protection IP 54 (IP 55 for NMS).

Motor suitable for operation with frequency converter from 1,1 kW.

Classification scheme IE3 for three-phase motors from 0,75 kW.

Constructed in accordance with: EN 60034-1; EN 60034-30-1.

Special features on request

- Other voltages. - Frequency 60 Hz (as per 60 Hz data sheet).
- Protection IP 55.- Special mechanical seal.
- Packed gland (only for NM standard construction).
- Single-phase motor (NMM) up to 1,5 kW.
- Higher or lower liquid or ambient temperatures.
- Motor suitable for operation with frequency converter up to 0,75 kW.

Coverage chart n ≈ 2900 rpm

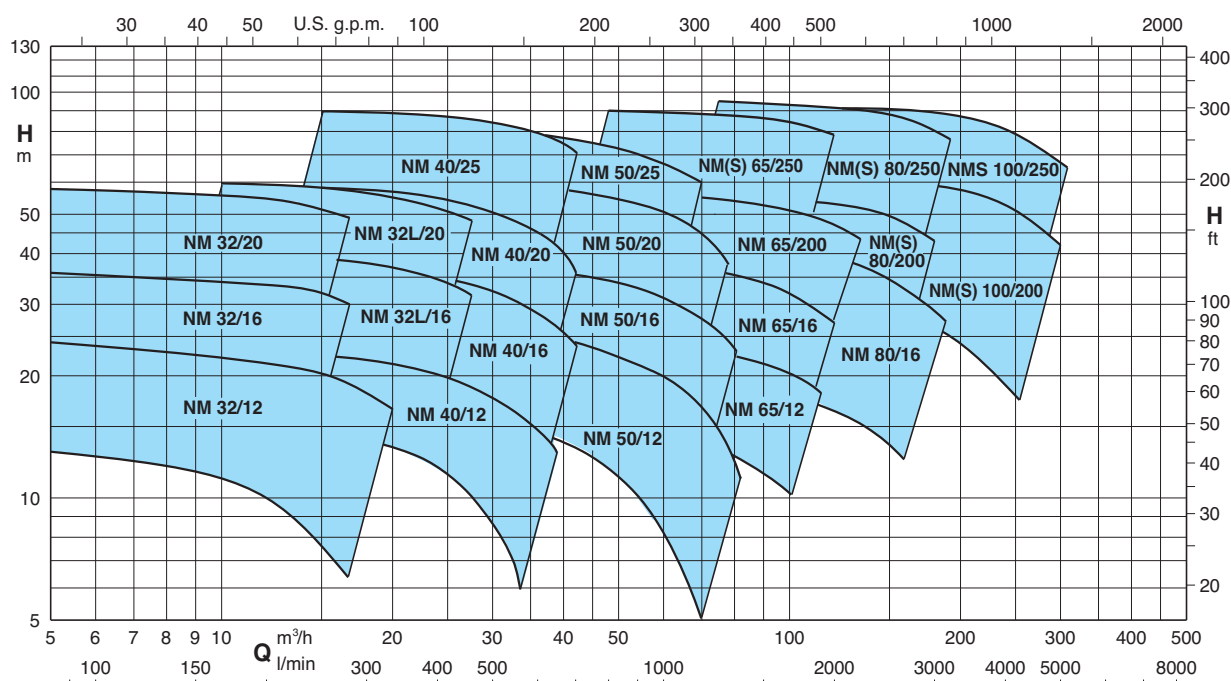

Pumps with frequency converter

The **NM EI** pumps are available with power from 0,55 kW up to 22 kW, the pumps are equipped with **I-MAT** installed on board which allows to realize a variable-speed system extremely compact and efficient, ideal in applications of water supply and in the distribution of hot and cold water.

The pump is equipped with transducers suitable for operation and is already programmed at the factory.

Advantages

- Energy saving
- Compact design
- Easy to use
- Programmable to suit the system requirements
- Reliability

Costruction

The system comprises of:

- Pump
- Induction motor
- I-MAT Frequency converter
- Motor adapter for the motor mounting of the frequency converter
- Connection cable between frequency converter and induction motor
- Transducers

Main features

- Rated motor power output from 0,55 kW to 22 kW
- Control range from 1750 to 2900 rpm (2-pole)
- Protection against dry running
- Protection against operations with closed valve ports
- Protection against system leakages
- Protection against overcurrent in the motor
- Protection against overvoltage and undervoltage of the power supply
- Protection against current unbalances between phases



Operating modes



Constant pressure mode with pressure transducer

In this mode, the system maintains the preset pressure when the flow required by the installation changes.

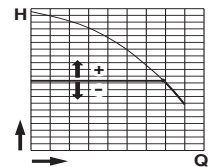

Proportional pressure mode with pressure transducer

In this mode the system changes the working pressure according to the required flow rate.

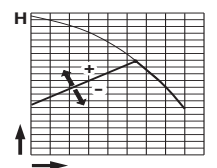

Constant flow mode with flow meter

In this mode the system maintains a constant flow rate value in a point of the installation according to the required pressure.

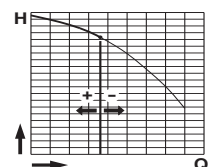

Fixed speed mode with setting of the speed preferential rotation.

In this mode, by changing the working frequency, you may choose any operational curve included within the working range.

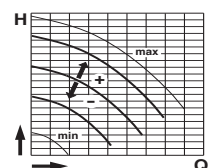

Constant temperature mode with temperature transducer

In this mode the system keeps the temperature constant inside a system by changing the speed of the pump.

Performance n ≈ 2900 rpm

B-NM	NM	P ₂		Q m³/h l/min	6,6	7,5	8,4	9,6	10,8	12	13,2	15	16,8	18,9	21	24	27	30
		kW	HP		H m	110	125	140	160	180	200	220	250	280	315	350	400	450
B-NM 32/12F	NM 32/12FE	0,55	0,75	H m	12,5	12,5	12	11,5	11	10	9	7,5						
B-NM 32/12D	NM 32/12DE	0,75	1		18	18	17,5	17	16,5	16	15,5	14						
B-NM 32/12A/A	NM 32/12A/A	1,1	1,5		23	23	22,5	22	21,5	21	20,5	19						
B-NM 32/12S/A	NM 32/12S/A	1,5	2		23,5	23,5	23	22,5	22	21,5	21	20,5			18,5	16,5	13	
B-NM 32/16B/A	NM 32/16B/A	1,5	2		29,5	29,5	29	28,5	27,5	27	26	25*	22,5*					
B-NM 32/16A/B	NM 32/16A/B	2,2	3		35,5	35,5	35	34,5	34	33,5	33	32*	30*					
B-NM 32/20D/B	NM 32/20D/B	2,2	3		38	37,5	37	36	35	33,5	32							
B-NM 32/20C/A	NM 32/20C/A	3	4		45	44,5	44	43,5	42,5	41	40	38	36					
B-NM 32/20A/B	NM 32/20A/B	4	5,5		57,5	57	56	55,5	55	54,5	53,5	51,5	49					

B-NM	NM	P ₂		Q m³/h l/min	9,6	10,8	12	13,2	15	16,8	18,9	21	24	27	29	32	37,8	39
		kW	HP		H m	160	180	200	220	250	280	315	350	400	450	483	533	630
B-NM 32L/16C	NM 32L/16C	2,2	3	H m	25,1	24,9	24,7	24,4	23,8	23	21,8	20,3	17,3	13,4				
B-NM 32L/16B	NM 32L/16B	3	4		30,4	30,3	30,2	30	29,6	29	28,1	26,8	24,2	20,8	17,9			
B-NM 32L/16A	NM 32L/16A	4	5,5		39,9	39,9	39,8	39,6	39,3	38,8	37,9	36,8	34,7	31,9	29,7	25,6		
B-NM 32L/20C	NM 32L/20C	4	5,5		42,1	41,8	41,5	41	40,2	38,9	37	34,5	29,7	23,8				
B-NM 32L/20B	NM 32L/20B	5,5	7,5		51,7	51,6	51,4	51,2	50,7	50	48,8	47	43,2	37,8	33,5			
B-NM 32L/20A	NM 32L/20A	7,5	10		59,4	59,4	59,4	59,4	59,2	58,8	58	56,6	53,4	48,6	44,6	37,7		

B-NM	NM	P ₂		Q m³/h l/min	15	16,8	18,9	21	24	27	30	33	37,8	39	42	45	48	54
		kW	HP		H m	250	280	315	350	400	450	500	550	630	650	700	750	800
B-NM 40/12F/A	NM 40/12F/B	1,1	1,5	H m	14	13,5	13	12	11	9,5	8	6						
B-NM 40/12C/A	NM 40/12C/B	1,5	2		17,5	17	16,5	16	15	13,5	12	10,5	7,5	6,5				
B-NM 40/12A/B	NM 40/12A/C	2,2	3		22	22	21,5	21	20	19	18	16,5	14	13	11,5			
B-NM 40/16C/B	NM 40/16C/C	2,2	3		23	22,5	22	21,5	20	18,5	16,5	14,5	11	10				
B-NM 40/16B/A	NM 40/16B/B	3	4		29	28,8	28	27,5	26,5	25	23,5	21,5	18	17	14			
B-NM 40/16A/B	NM 40/16A/C	4	5,5		37	36,5	36,5	36	35	33,5	32	30,5	27	26	23,5	20	17	
B-NM 40/20D/B	NM 40/20D/B	4	5,5		39	38	37	35,5	33,5	30,5	27	22,5	14					
B-NM 40/20C/B	NM 40/20C/B	4	5,5		41,5	40,5	39,5	38	36	33,5								
B-NM 40/20B/A	NM 40/20B/A	5,5	7,5		50	49,5	48,5	47,5	45,5	43,5	41,5	37,5	30,5					
B-NM 40/20AR/A	NM 40/20AR/A	5,5	7,5		55	54,5	54	53	51	49								
B-NM 40/20A/A	NM 40/20A/A	7,5	10		57,5	57	56,5	55,5	54,5	52,5	50,5	48	42,5	40,5	35			
B-NM 4025/C/C	NM 40/25C/C	9,2	12,5		61	61	60,5	59,5	58,5	56,5	53,5	49,5	41,5	40	33,5			
B-NM 4025/B/C	NM 40/25B/C	11	15		69,5	69,5	69	68,5	67	65,5	63,5	60,5	53,5	51	45			
B-NM 4025/A/C	NM 40/25A/C	15	20		90	90	89,5	89	88,5	87	85	83	77,5	76	70,5			

B-NM	NM	P ₂		Q m³/h l/min	24	27	30	33	37,8	42	48	54	60	66	69	72	75	78	81	84
		kW	HP		H m	400	450	500	550	630	700	800	900	1000	1100	1150	1200	1250	1300	1350
B-NM 50/12F/B	NM 50/12F/C	2,2	3	H m			15,5	15	14	13,5	12	10	8	6						
B-NM 50/12D/A	NM 50/12D/B	3	4				20	19,5	18,5	18	16,5	14,5	13	10,5	9	8				
B-NM 50/12A/B	NM 50/12A/C	4	5,5				24	24	23	22,5	21	19,5	17,5	15	14	12,5	11,5	10		
B-NM 50/12S/B	NM 50/12S/C	4	5,5				26,5	26	25,5	24,5	23,5	22	20	18	16,5	15,5	14	13	11	
B-NM 50/16B/B	NM 50/16B/B	5,5	7,5				31	30,5	29,5	28	26	24	21,5	19	17,5	15,5	13,5	11,5	9,5	
B-NM 50/16A/B	NM 50/16A/B	7,5	10				38,5	38	37,5	36,5	34,5	32,5	30	27	25,5	24	22,5	20,5	19	
B-NM 50/20B/C	NM 50/20B/C	9,2	12,5		48	47,5	47,5	47	45,5	44,5	42,5	40	37	33	30,5	28	25,5	23		
B-NM 50/20A/C	NM 50/20A/C	11	15		55	55	54,5	54,5	53,5	52	50	48	45	41,5	39,5	37	35	32,5		
B-NM 50/20S/C	NM 50/20S/C	15	20		60	60	59,5	59,5	58,5	57,5	55,5	53,5	50,5	47	45	43	40,5	37		
B-NM 5025/C/C	NM 50/25C/C	11	15		55	54,5	54	53	51,5	49,5	46	41,5	35,5	28,5	24,5					
B-NM 5025/B/C	NM 50/25B/C	15	20		69	68,5	68	67,5	66	64	61	57	52,5	46,5	43					
B-NM 50/25A	NM 50/25A/D	18,5	25		80,5	80,5	80	79,5	78,5	77	74,5	71,5	67	61,5	58,5					

Performance n ≈ 2900 rpm

B-NM - B-NMS	NM - NMS	P ₂		Q m³/h l/min	37,8	42	48	54	60	66	75	84	96	108	120	132	141	150
		kW	HP		630	700	800	900	1000	1100	1250	1400	1600	1800	2000	2200	2350	2500
		H m																
B-NM 65/12E/A	NM 65/12E/C	4	5,5	16,5	16,4	16,2	15,9	15,5	15,1	14,3	13,2	11,4	9,2					
B-NM 65/125C/B	NM 65/12C/B	5,5	7,5	21,1	21	20,8	20,6	20,3	19,9	19,1	18,2	16,5	14,4	11,8				
B-NM 65/125A/B	NM 65/12A/B	7,5	10	25,9	25,8	25,6	25,4	25,1	24,8	24,1	23,3	21,9	20	17,6				
B-NM 65/160D/B	NM 65/16D/B	7,5	10			24,3	24,1	23,9	23,6	23,1	22,3	20,8	18,8	16,3				
B-NM 65/160C/C	NM 65/16C/C	9,2	12,5			28,1	28,0	27,8	27,6	27,1	26,3	24,9	23,1	20,7	17,7			
B-NM 65/160B/C	NM 65/16B/C	11	15			32,6	32,5	32,3	32	31,5	30,8	29,5	27,9	25,7	23,0			
B-NM 65/160AR	NM 65/16AR	15	20			36,4	36,3	36,2	35,9	35,5	34,8	33,7	32,1	30,0	27,5			
B-NM 65/160A/C	NM 65/16A/C	15	20			40,5	40,4	40,2	40	39,5	38,8	37,6	36,1	34,2	31,7			
B-NM 65/200C/C	NM 65/20C/C	15	20			44	43,8	43,5	43,1	42,3	41,2	39,4	37,1	34,4	31,4	28,8		
B-NMS 65/200B	NM 65/20B/D	18,5	25			50,5	50,4	50,2	49,9	49,2	48,3	46,8	44,8	42,5	39,8	37,5		
B-NMS 65/200A	NM 65/20A/A	22	30			57	57	57	56,5	56	55,5	54	52,5	50	47,5	45,5		
B-NMS 65/250C	NM 65/25C/A	22	30			61	61	60,5	60	58,5	57	54,5	51,5	47,5	43			
B-NMS 65/250B/A	NMS 65/250B/A	30	40			73,5	73,5	73,5	73,5	73	71,5	69,5	66,5	63	59			
B-NMS 65/250A/B	NMS 65/250A/B	37	50			86,5	86,5	87	86,5	86	85,5	83,5	81	78	74,5			

B-NM - B-NMS	NM - NMS	P ₂		Q m³/h l/min	75	84	96	108	120	132	150	168	180	192	210	240	270	300
		kW	HP		1250	1400	1600	1800	2000	2200	2500	2800	3000	3200	3500	4000	4500	5000
		H m																
B-NM 80/160E/B	NM 80/16E/B	7,5	10	21,5	20,9	19,9	18,7	17,4	15,9	13,4	10,6							
B-NM 80/160D/C	NM 80/16D/C	9,2	12,5	25,2	24,5	23,5	22,4	21,1	19,6	17,2	14,4							
B-NM 80/160C/C	NM 80/16C/C	11	15	28,7	28,2	27,4	26,4	25,1	23,8	21,3	18,5	16,4						
B-NM 80/160B/C	NM 80/16B/C	15	20	34,8	34,5	33,8	33	32,1	30,9	28,9	26,4	24,5	22,4					
B-NM 80/16A	NM 80/16A/D	18,5	25	39,9	39,6	39	38,2	37,4	36,4	34,5	32,2	30,3	28,1					
B-NMS 80/200B/A	NM 80/20B	22	30	46,5	46	45,5	44,5	43,5	42	39*	35,5*	32*						
B-NMS 80/200A/A	NMS 80/200A	30	40	56	55,5	55	54	53	52	49,5*	46*	43*						
B-NMS 80/250E/A	NM 80/25E	22	30	51	50	48,5	46,5	44,5	42	38*	33*	29*						
B-NMS 80/250D/A	NMS 80/250D	30	40	65	64	62,5	61	59	56,5	53*	49*	45,5*	41*					
B-NMS 80/250C/A	NMS 80/250C/A	37	50	73,5	73	72	70,5	69	67	63*	59*	55,5*	51,5*					
B-NMS 80/250B/A	NMS 80/250B/A	45	60	84	83,5	82,5	81,5	80	78	74,5*	70,5*	67*	63*					
B-NMS 80/250A/A	NMS 80/250A/A	55	75	95	94,5	93,5	92,5	91,5	90	87,5*	84*	80,5*	76,5*					
B-NMS 100/200E/B	NM 100/20E/A	18,5	25				30	29,5	29	28	27	26	25	23	19*			
B-NMS 100/200D/A	NM 100/20D	22	30				36	35,5	35	34	33	32	31	29	24,5*	19*		
B-NMS 100/200C/A	NMS 100/200C	30	40				45	44,5	44	43,5	42,5	41,5	40,5	39	34,5*	29*	22°	
B-NMS 100/200B/A	NMS 100/200B/A	37	50				54	53,5	53	52,5	51,5	50,5	49,5	48	44*	38,5*	32°	
B-NMS 100/200A/A	NMS 100/200A/A	45	60				61,5	61	60,5	60	59,5	58,5	58	56,5	53*	48*	42°	
B-NMS 100/250B/A	NMS 100/250B/A	55	75				73,5	73	72,5	71,5	70	68,5	67	65	61*	55,5*	48,5°	
B-NMS 100/250A/A	NMS 100/250A/A	75	100				91	90,5	90	89,5	88,5	88	87	85	81*	75*	67°	

NM(S) Standard construction.
B-NM(S) Bronze construction.

P₂ Rated motor power output.
H Total head in m.

* Maximum suction lift 1-2 m.
◦ With 1 m suction head.
Tolerances according to UNI EN ISO 9906:2012

Rated currents

P ₂		230V Δ / 400V Y			IA/IN
kW	HP	IN A	IN A	IN A	
0,55	0,75	4	2,3	4,8	
0,75	1	4	2,3	6,1	
1,1	1,5	4,6	2,7	5,5	
1,5	2	7,5	4,3	6,1	
2,2	3	9,2	5,3	8,4	
3	4	11,5	6,6	8,2	
4	5,5		9,6	5,5	8,9
5,5	7,5		10,8	6,2	9,1
7,5	10		14,3	8,3	9,1
9,2	12,5		18,5	10,7	8,2
11	15		21,5	12,4	8,5
15	20		27,3	15,8	9,5
18,5	25		34	19,6	9,5
22	30		41	23,7	9,5
30	40		53	30,5	8,6
37	50		65	37,5	7,1
45	60		78	45	6,9
55	75		95	55	6,7
75	100		128	74	6,8

P₂ Rated motor power output.
IA/IN D.O.L. starting current / Nominal current

NM, NMS

Characteristic curves $n \approx 2900$ rpm

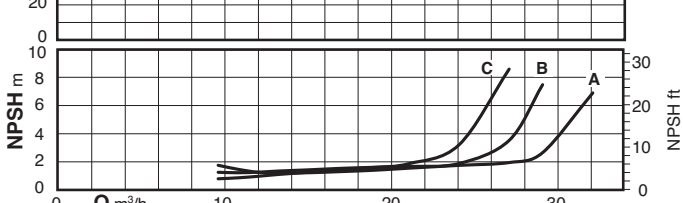
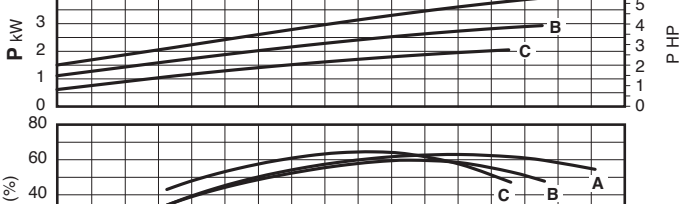
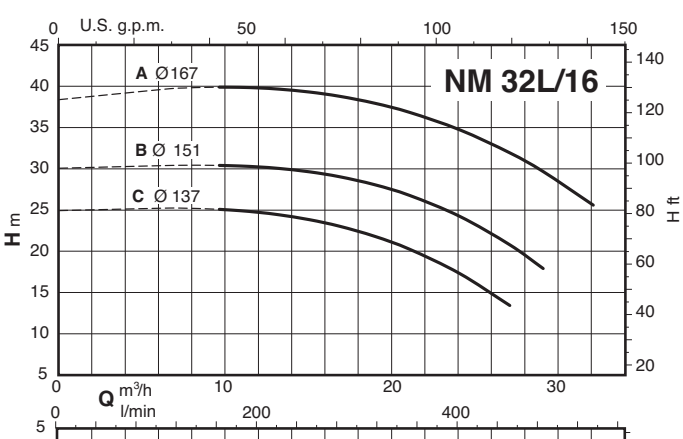
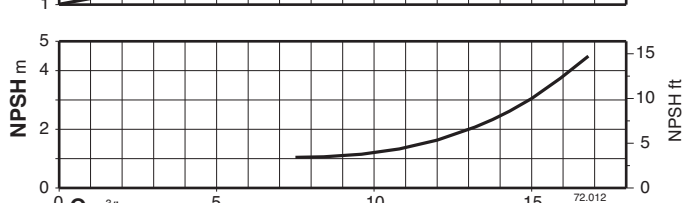
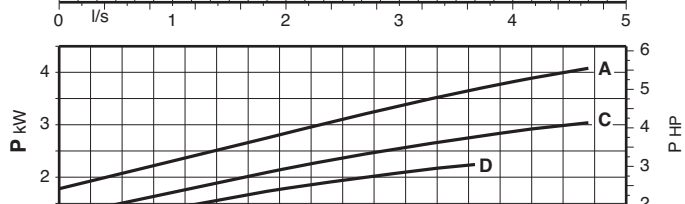
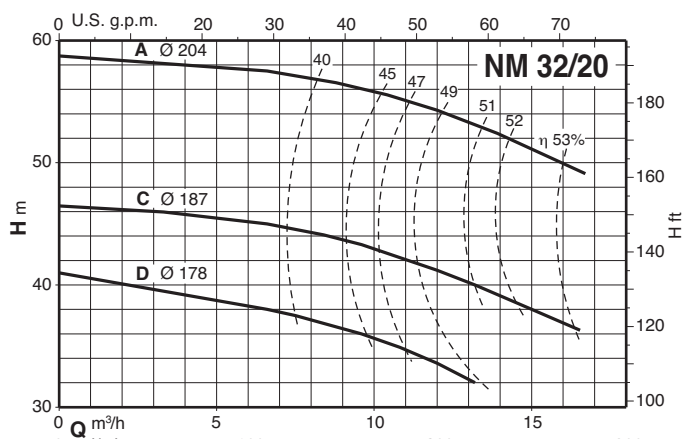
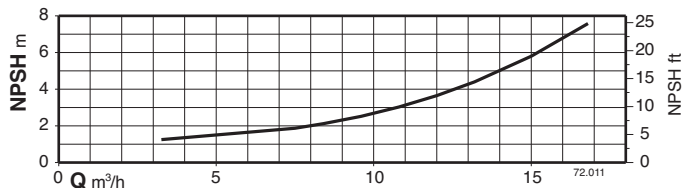
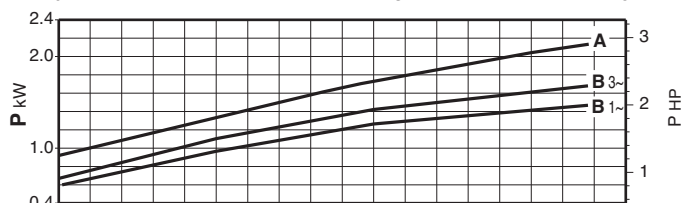
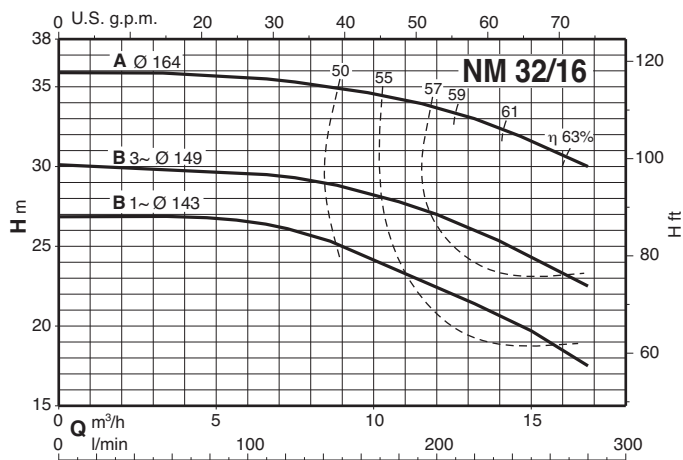
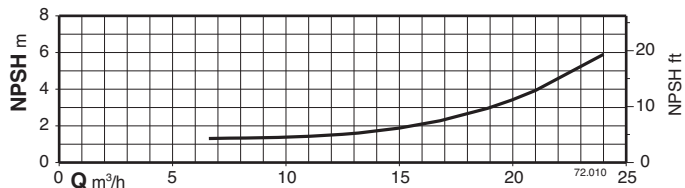
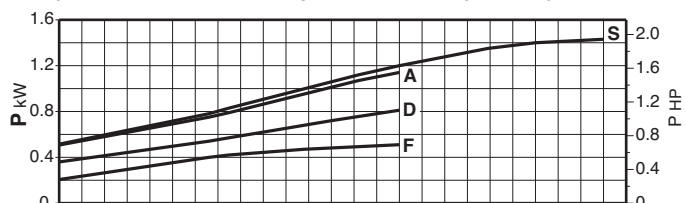
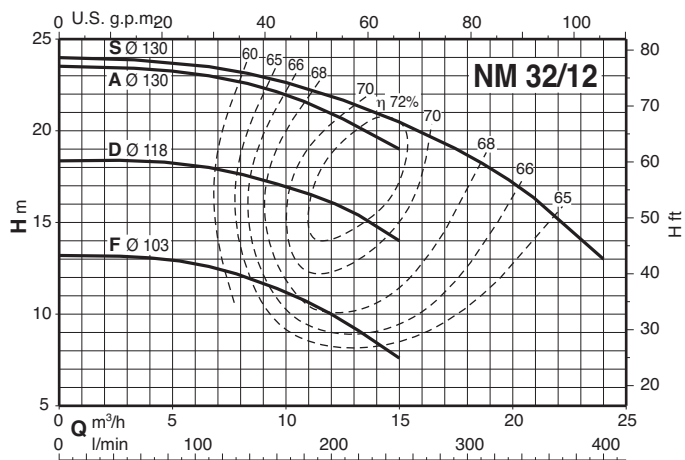

NM, NMS

Characteristic curves $n \approx 2900$ rpm

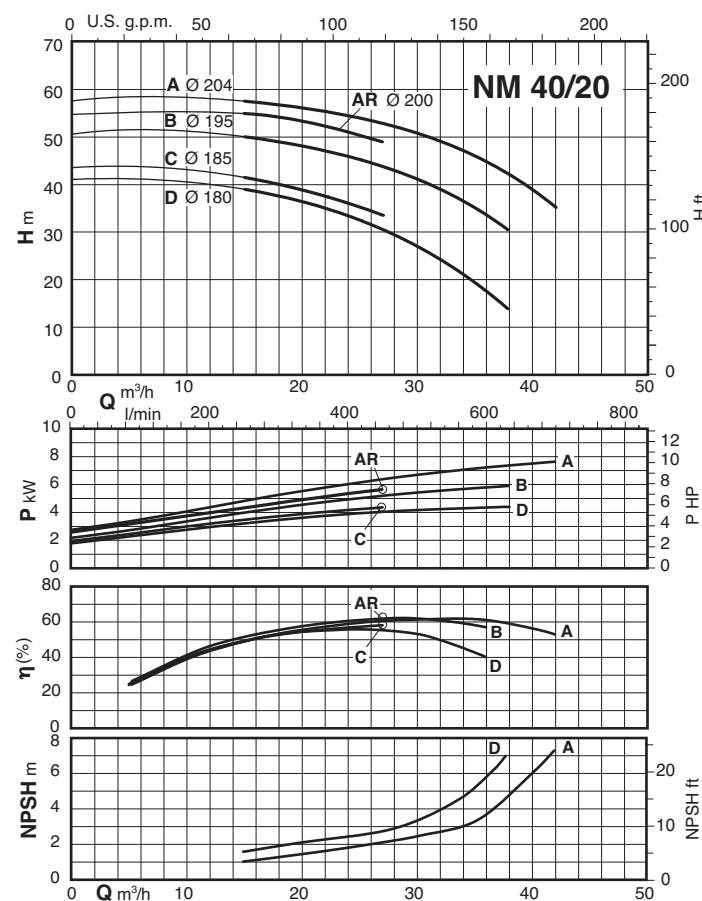
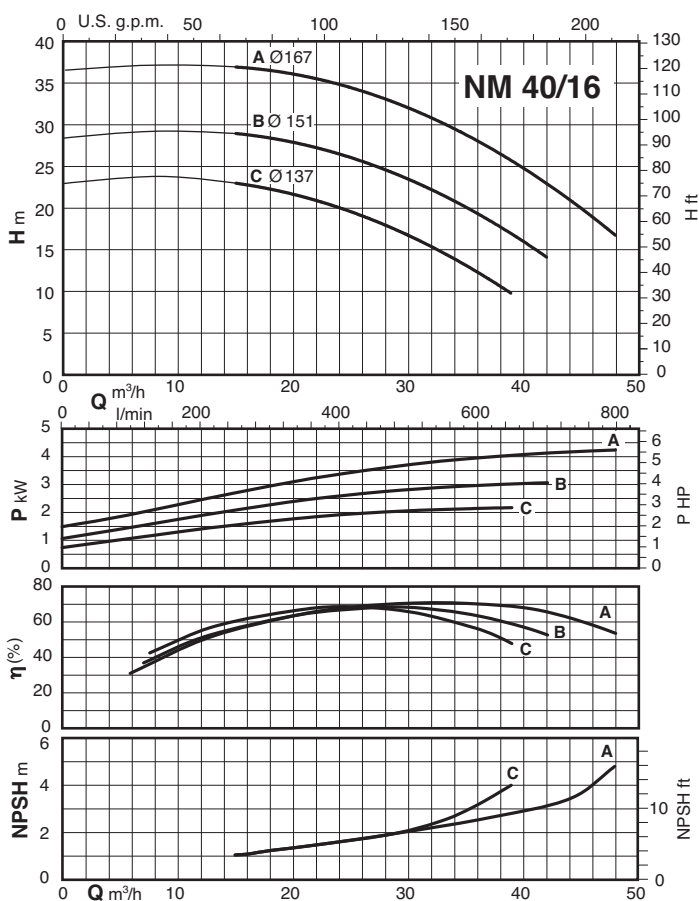
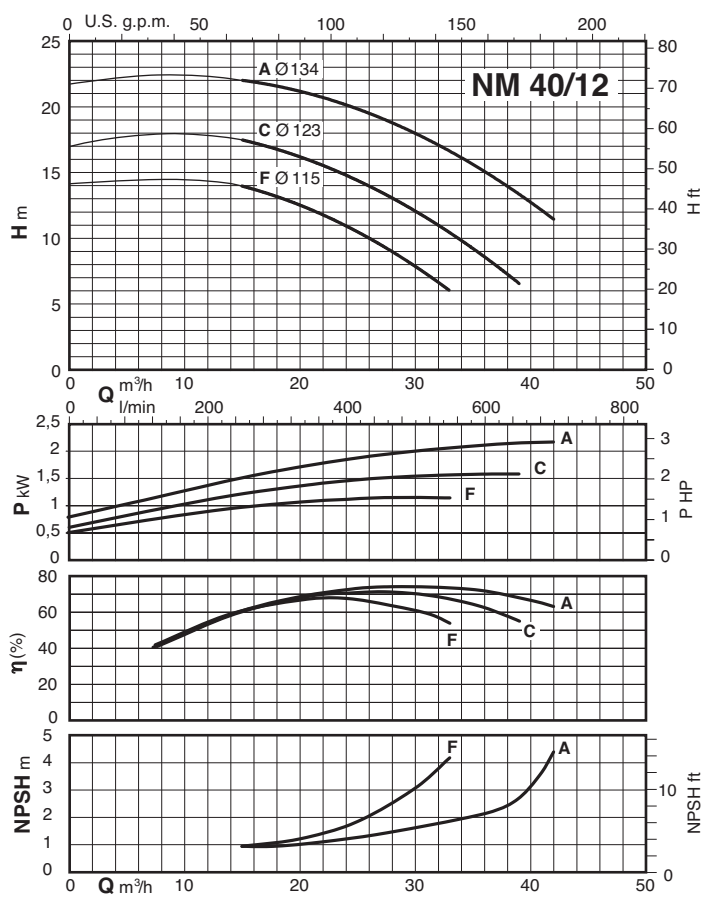
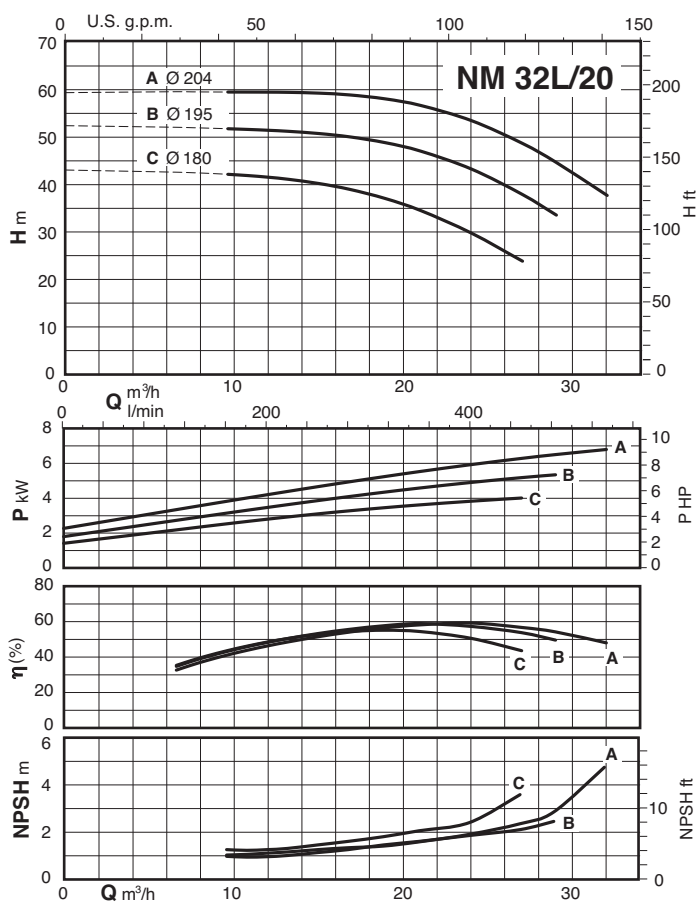

Characteristic curves $n \approx 2900$ rpm

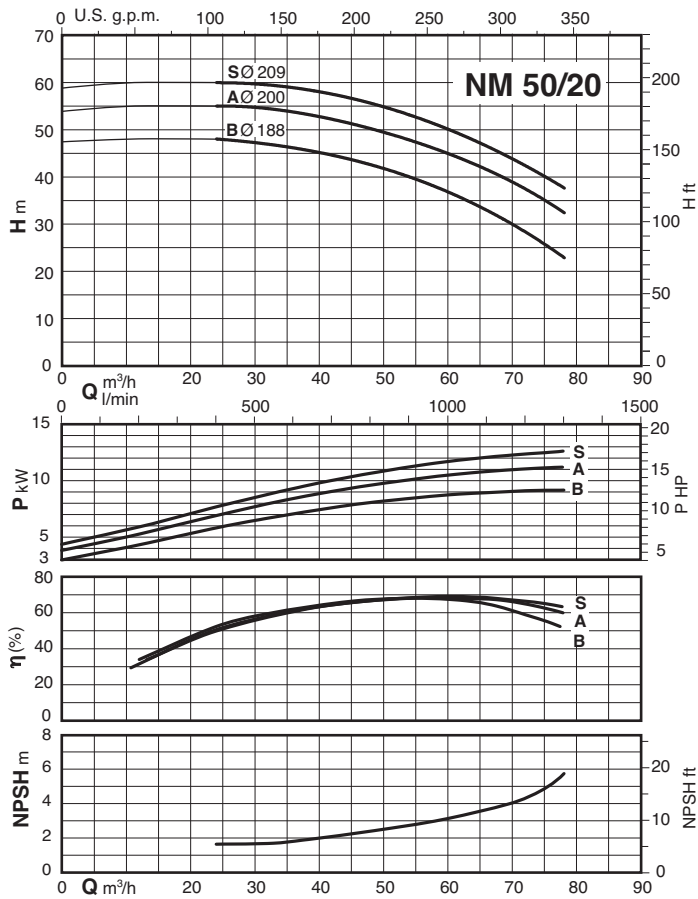
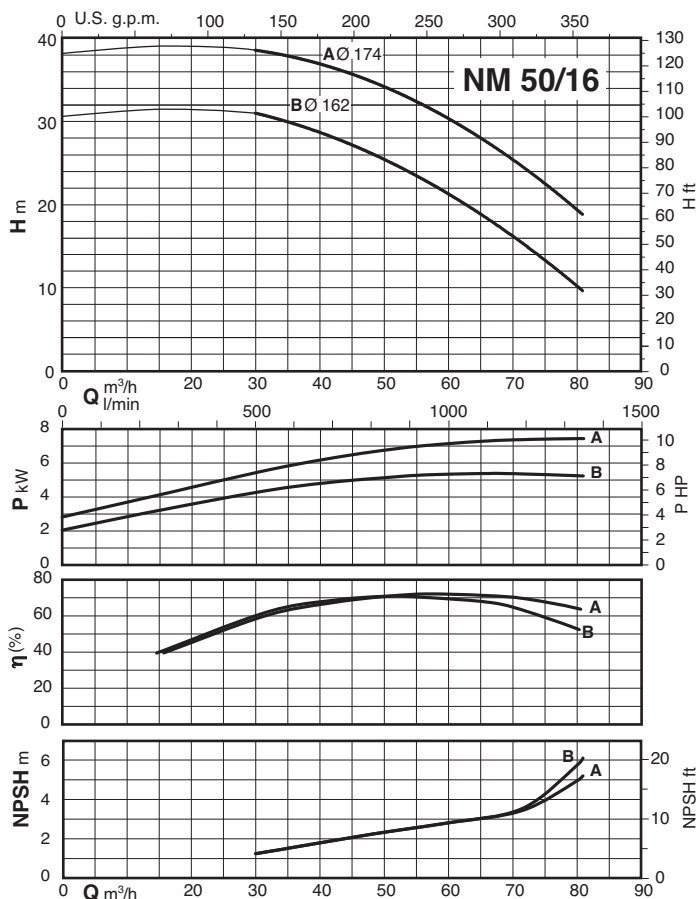
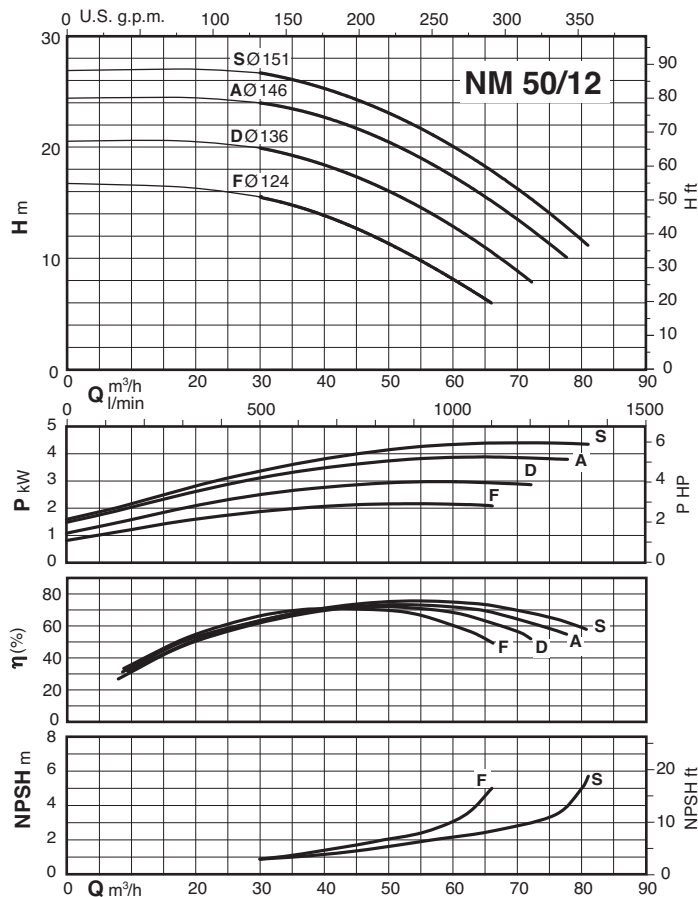
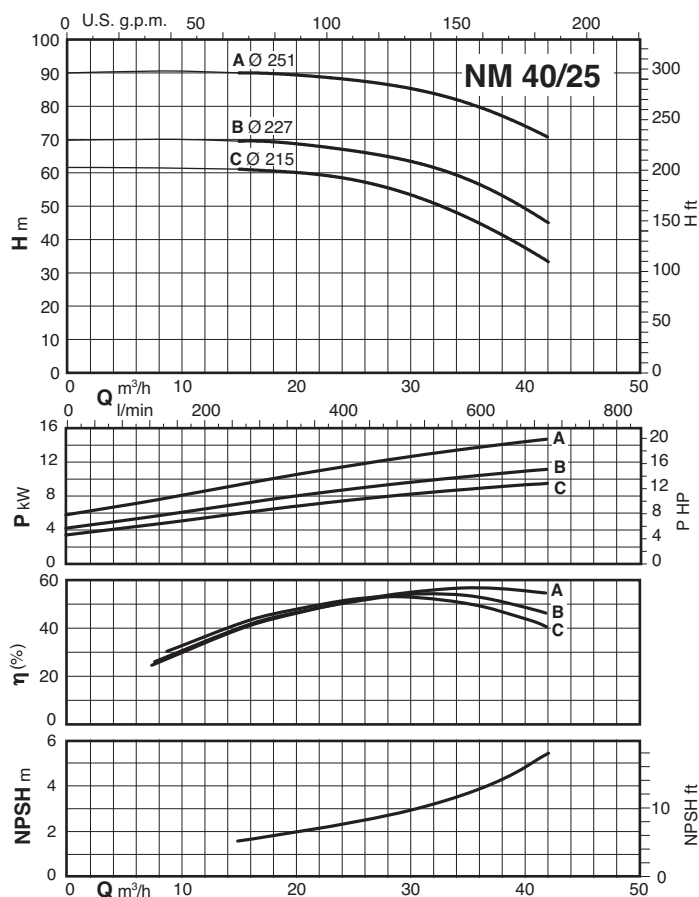

Characteristic curves $n \approx 2900$ rpm

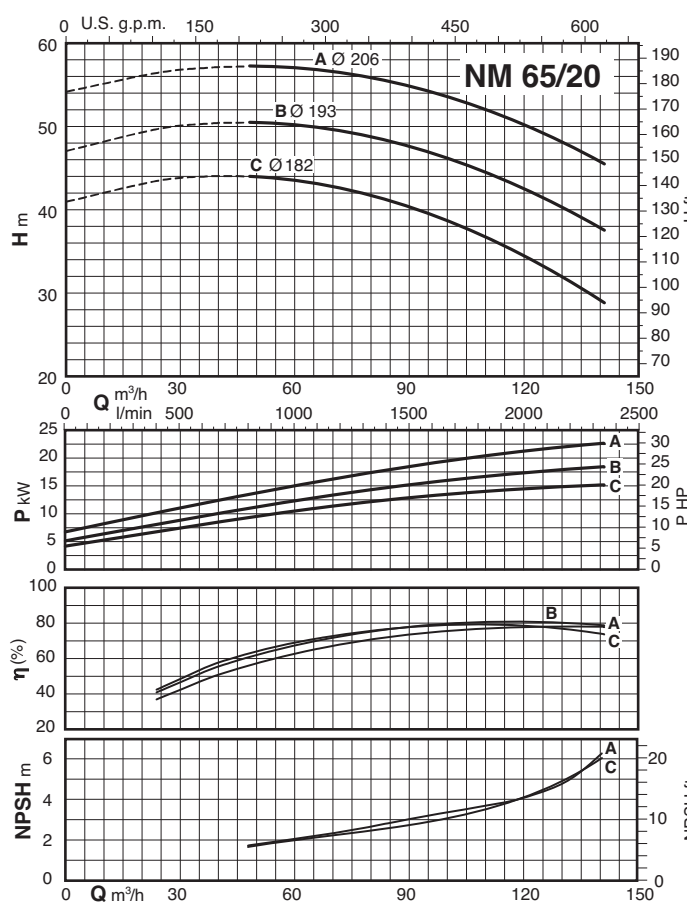
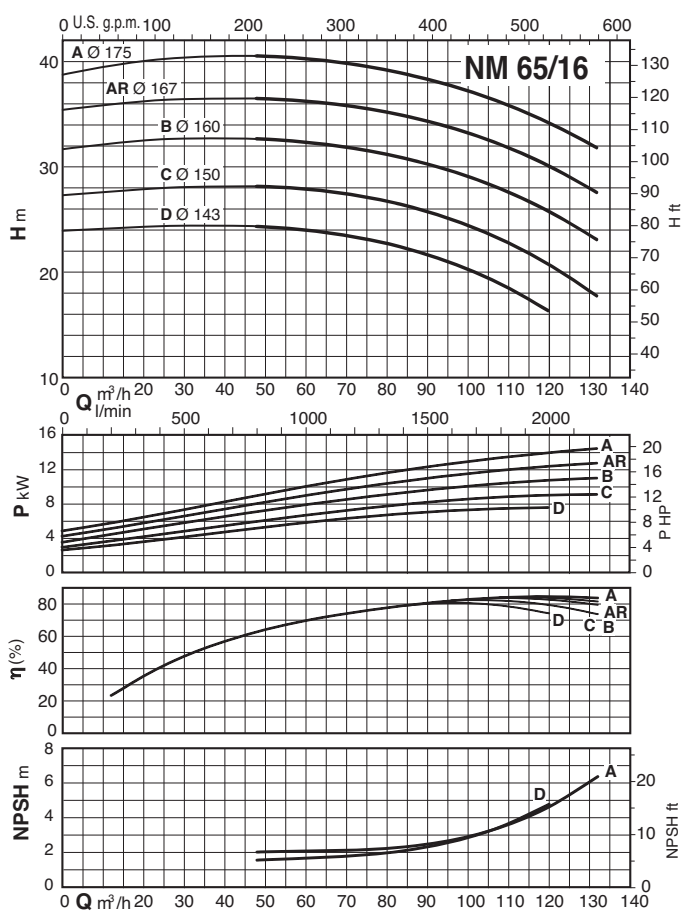
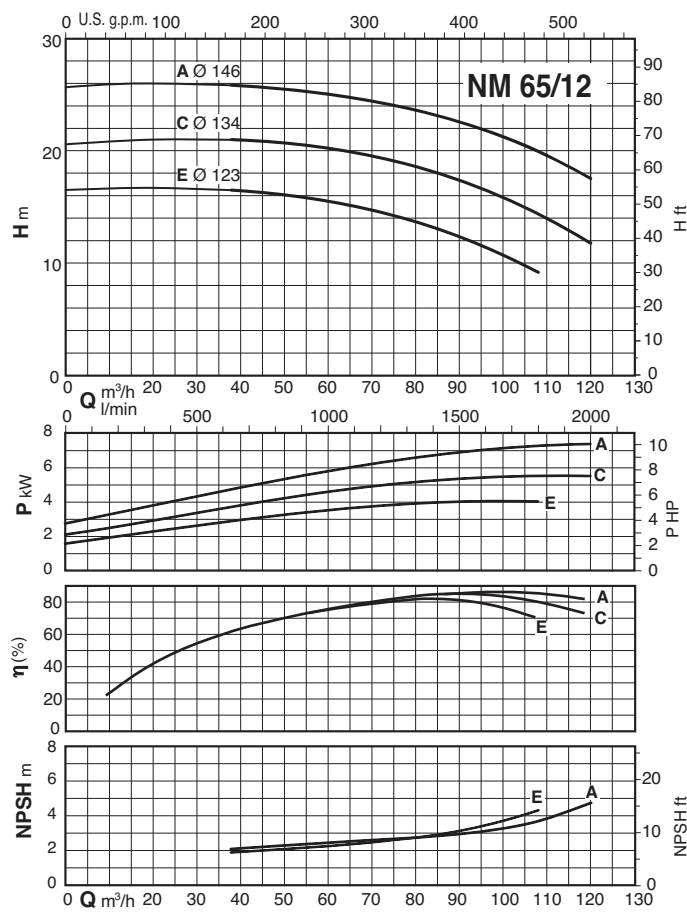
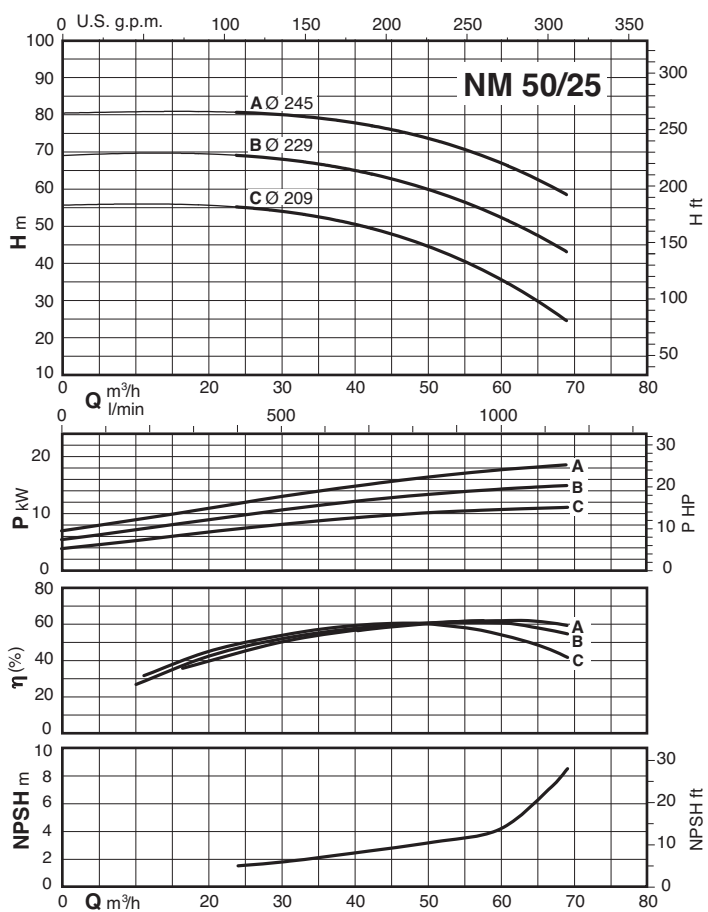

Characteristic curves n ≈ 2900 rpm

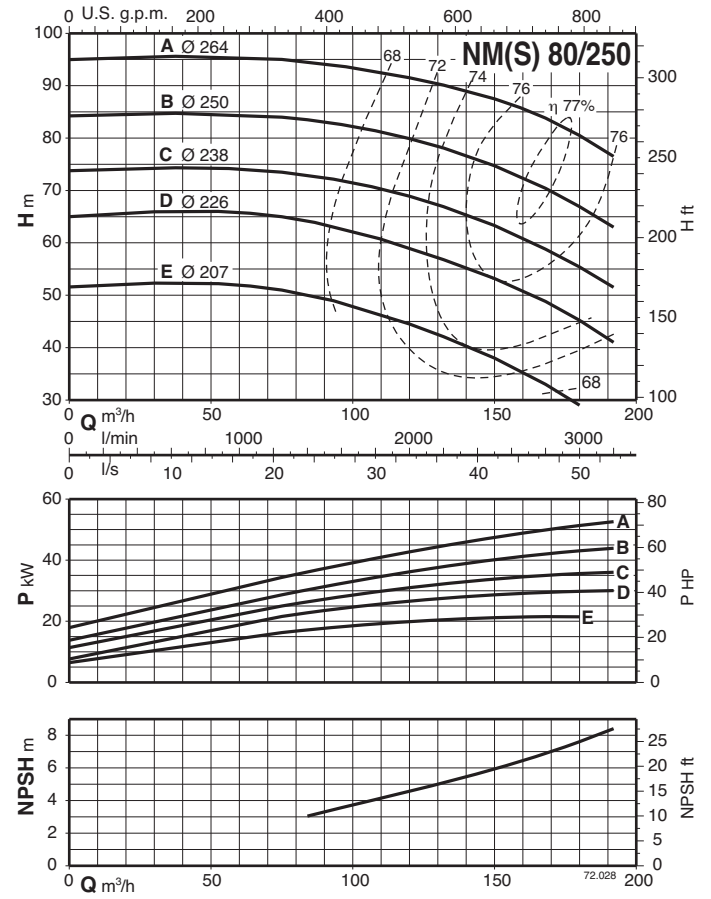
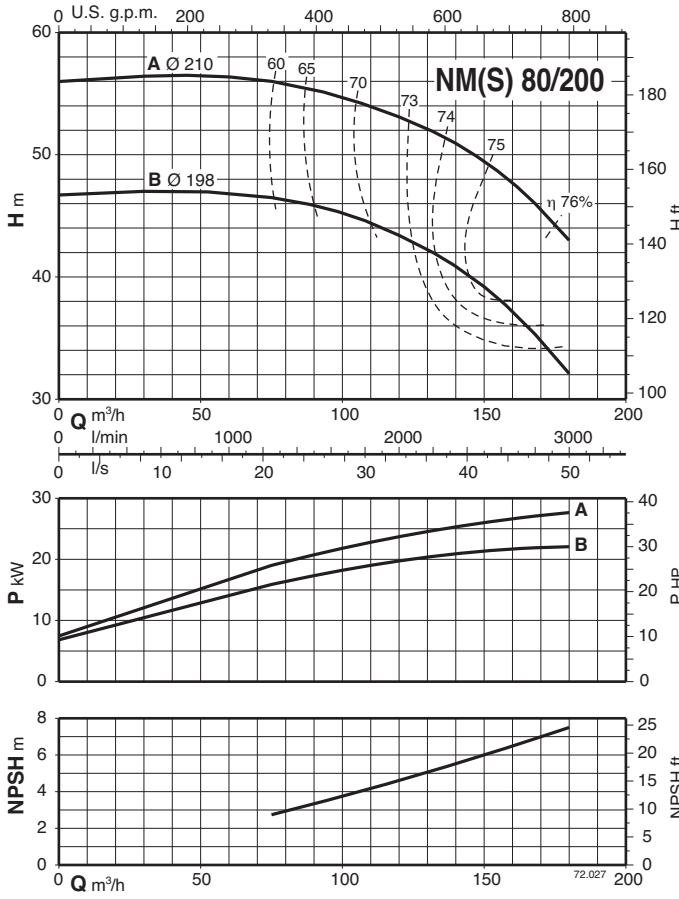
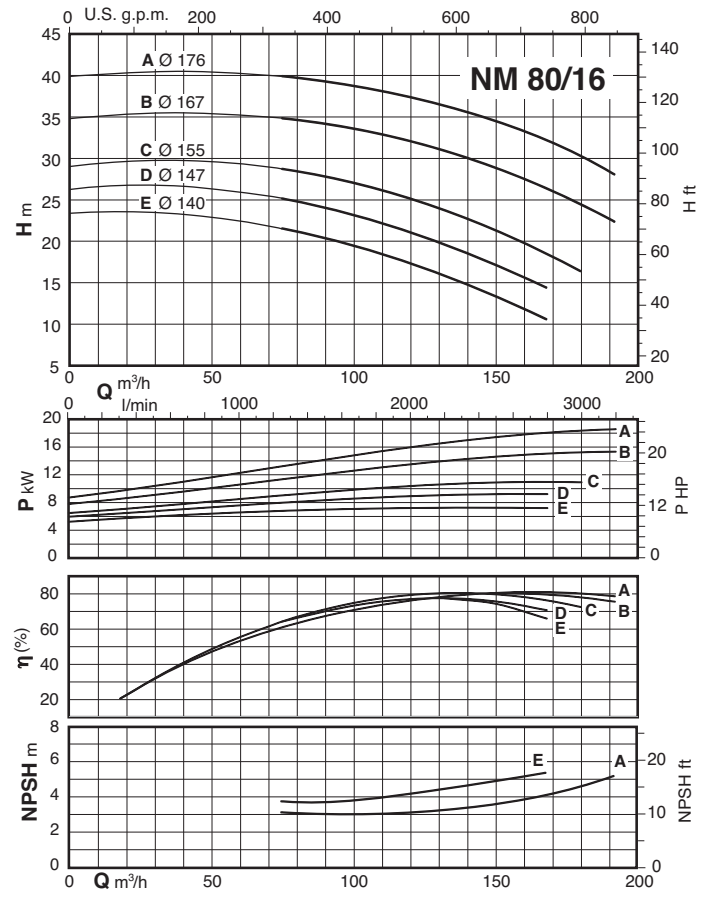
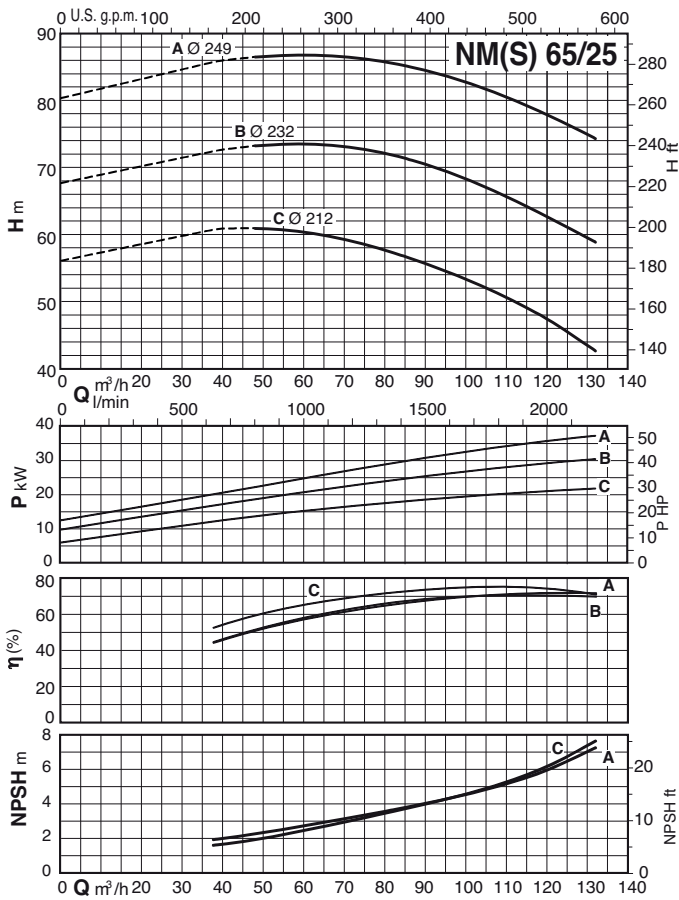

Characteristic curves n ≈ 2900 rpm

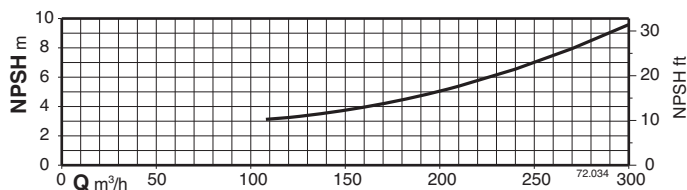
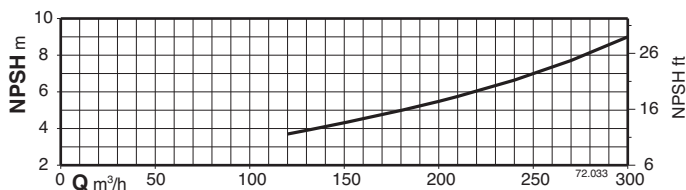
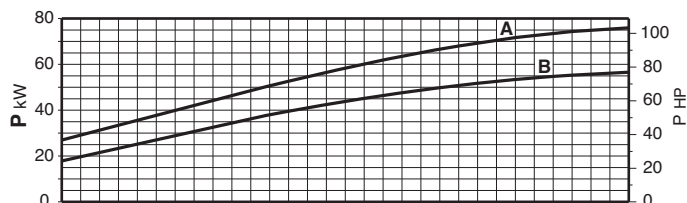
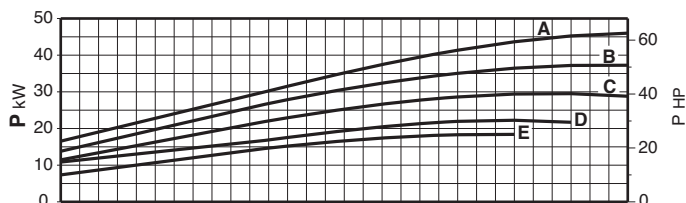
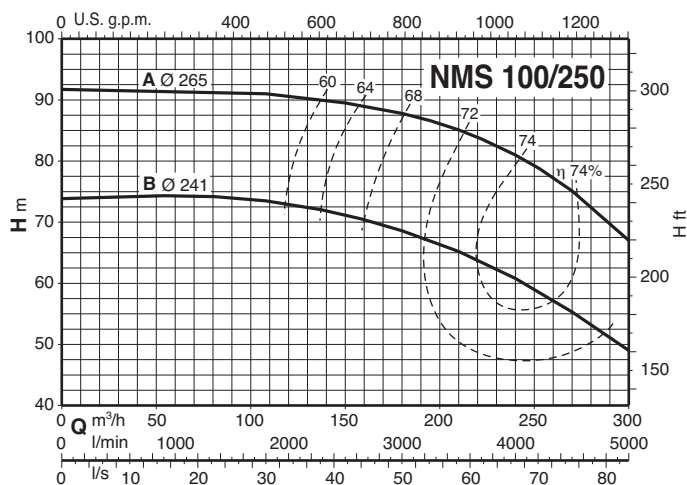
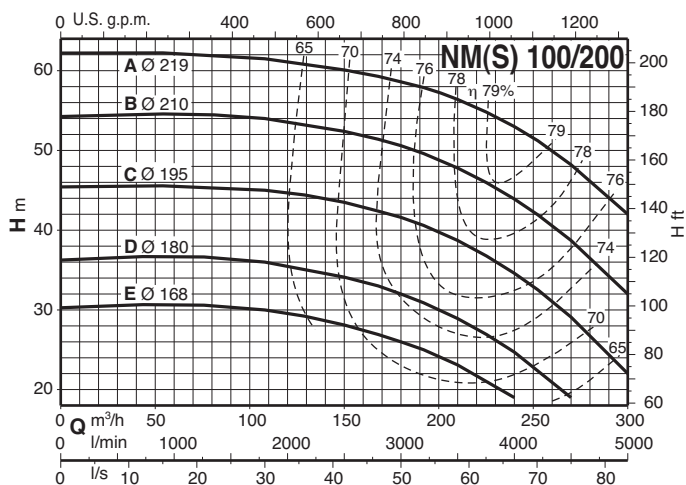

Dimensions and weights

Flanges EN 1092-2

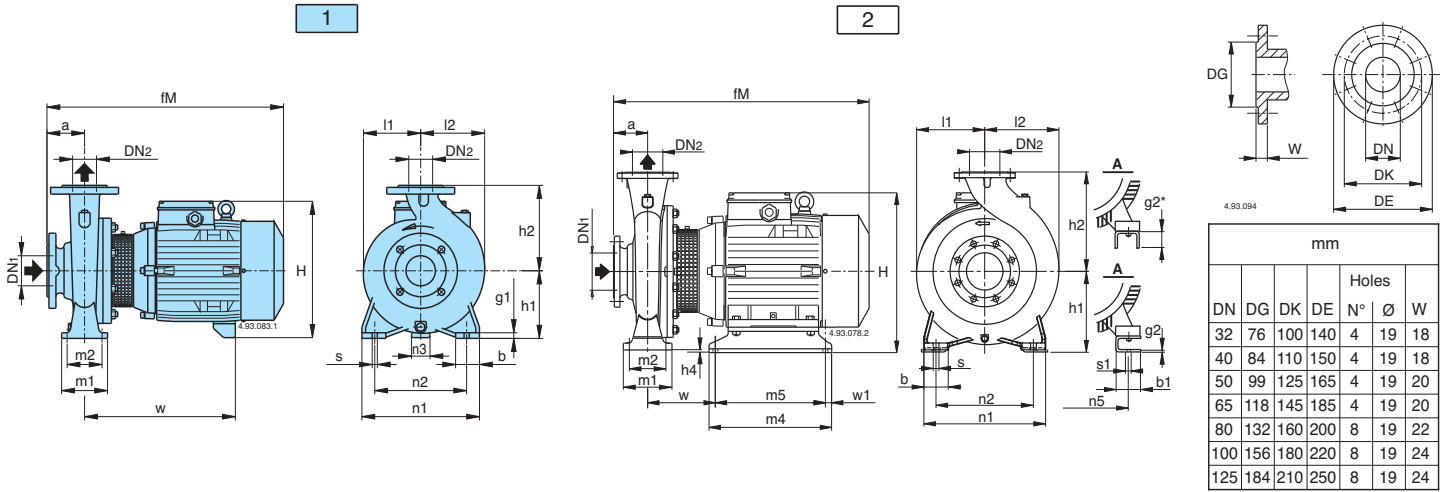

Picture	NM	mm																							kg					
		DN1	DN2	a	fm	h1	h2	H	h4	m1	m2	n1	n2	n3	n5	w1	b	b1	s	s1	l1	l2	w	m4	m5	g1	g2			
1	NM 32/12DE-FE NM 32/12S/A-A/A	50	32	80	405	112	140	240	-	100	70	190	140	37	-	-	50	-	14	-	93	97	245	-	-	12	-	24-24 27-26		
	NM 32/16B/A NM 32/16A/B	50	32	80	410 450	132	160	260	-	100	70	240	190	47	-	-	50	-	14	-	120	120	250 290	-	-	12	-	34 39		
	NM 32/20D/B NM 32/20C/A NM 32/20A/B	50	32	80	450 475 475		180	288 298 298	-	100	70	240	190	62 60 60	-	-	50	-	14	-	140	140	290 295 295	-	-	12	-	42 47 51		
	NM 32L/16C NM 32L/16B NM 32L/16A	50	32	80	450 475 475	132	160	260 270 270	-	100	70	240	190	47 45 45	-	-	50	-	14	-	121	121	290 295 295	-	-	10	-	38,6 45,6 47,6		
	NM 32L/20C NM 32L/20A-B	50	32	80	475 508	160	180	298 320	-	100	70	240	190	60 49	-	-	50	-	14	-	142	142	295 279	-	-	12	-	52 72-66		
	NM 40/12C/B-F/B NM 40/12A/C	65	40	80	410 450	112	140	240	-	100	70	210	160	37	-	-	50	-	14	-	100	113	250 290	-	-	12	-	29-27 32		
	NM 40/16C/C NM 40/16B/B NM 40/16A/C	65	40	80	450 475 475	132	160	260 270 270	-	100	70	240	190	47 45 45	-	-	50	-	14	-	121	122	290 295 295	-	-	10	-	39 46 48		
	NM 40/20C/B-D/B NM 40/20A/A-AR/A-B/A	65	40	100	495 528	160	180	298 320	-	100	70	265	212	60 49	-	-	50	-	14	-	142	142	295 279	-	-	12	-	54-53 73-67-67		
	NM 40/25C/C NM 40/25B/C NM 40/25A/C	65	40	100	640 690 715	180	225	365	-	125	95	320	250	50	-	-	65	-	14	-	175	175	400 460 460	-	-	15	-	108 117 139		
	NM 50/12F/C NM 50/12D/B NM 50/12A/C-S/C	65	50	100	470 495 495		160	260 270 270	-	100	70	240	190	47 45 45	-	-	50	-	14	-	122	137	290 295 295	-	-	10	-	40 47 50,5-50,6		
	NM 50/16A/B-B/B	65	50	100	528	160	180	320	-	100	70	265	212	49	-	-	50	-	14	-	126	140	279	-	-	12	-	70,5-64		
	NM 50/20B/C NM 50/20A/C NM 50/20S/C	65	50	100	640 690 720	160	200	345	-	100	70	265	212	40	-	-	50	-	14	-	140	153	400 460 460	-	-	15	-	100 109 131		
	NM 50/25C/C NM 50/25B/C	65	50	100	695 720	180	225	365	-	125	95	320	250	50	-	-	65	-	14	-	175	175	465 465	-	-	15	-	122 145		
	2	NM 50/25A/D	65	50	100	766	180	225	386	-	125	95	320	250	-	254	20	65	60	14	15	175	175	166	394	354	-	20*	-	
	1	NM 65/12E/C NM 65/12A/B-C/B	80	65	100	500 533	160	180	298 320	-	125	95	280	212	60 49	-	-	65	-	14	-	130	154	300 284	-	-	12	-	51,9 70,7-64,7	
		NM 65/16D/B NM 65/16C/C NM 65/16B/C NM 65/16A/C-AR	80	65	100	528 640 690 715	160	200	320 345 345 345	-	125	95	280	212	49 40 40 40	-	-	65	-	14	-	140	161	279 410 410 460	-	-	12	-	70,5 93 112 127	
		NM 65/20C/C	80	65	100	715	180	225	365	-	125	95	320	250	50	-	-	65	-	14	-	159	179	460	-	-	12	-	134	
		2	NM 65/20A/A-B/D	80	65	100	762	180	225	386	-	125	95	320	250	-	254	20	65	60	14	15	159	179	175	394	354	-	20*	--
		NM 65/25C/A	80	65	100	762	202	250	408	2	160	120	360	280	-	254	20	80	90	18	14	179	185	182	400	360	-	42*	187	
	1	NM 80/16E/B NM 80/16D/C NM 80/16C/C NM 80/16B/C	100	80	125	553 670 720 745	180	225	340 365 365 365	-	125	95	320	250	60 50 50 50	-	-	65	-	14	-	153	181	279 415 465 465	-	-	12	-	77,5 101 120 132	
2		NM 80/16A/D	100	80	125	789	180	225	386	-	125	95	320	250	-	254	20	65	60	14	15	153	181	164	394	354	-	20*	-	
NM 80/20B		100	80	125	787	202	250	408	22	125	95	345	280	-	254	20	65	90	18	14	170	194	182	400	360	-	42*	180		
NM 80/25E		100	80	125	787	202	280	408	2	160	120	400	315	-	254	20	80	90	18	14	191	210	182	400	360	-	42*	193		
2	NM 100/20D-E/A	125	100	125	787	200	280	406	-	160	120	360	280	-	254	20	80	90	18	15	180	212	162	394	354	-	40*	--		

Pumps with packed gland, dimensions available on request (excluded NMS).

NM, NMS

Dimensions and weights

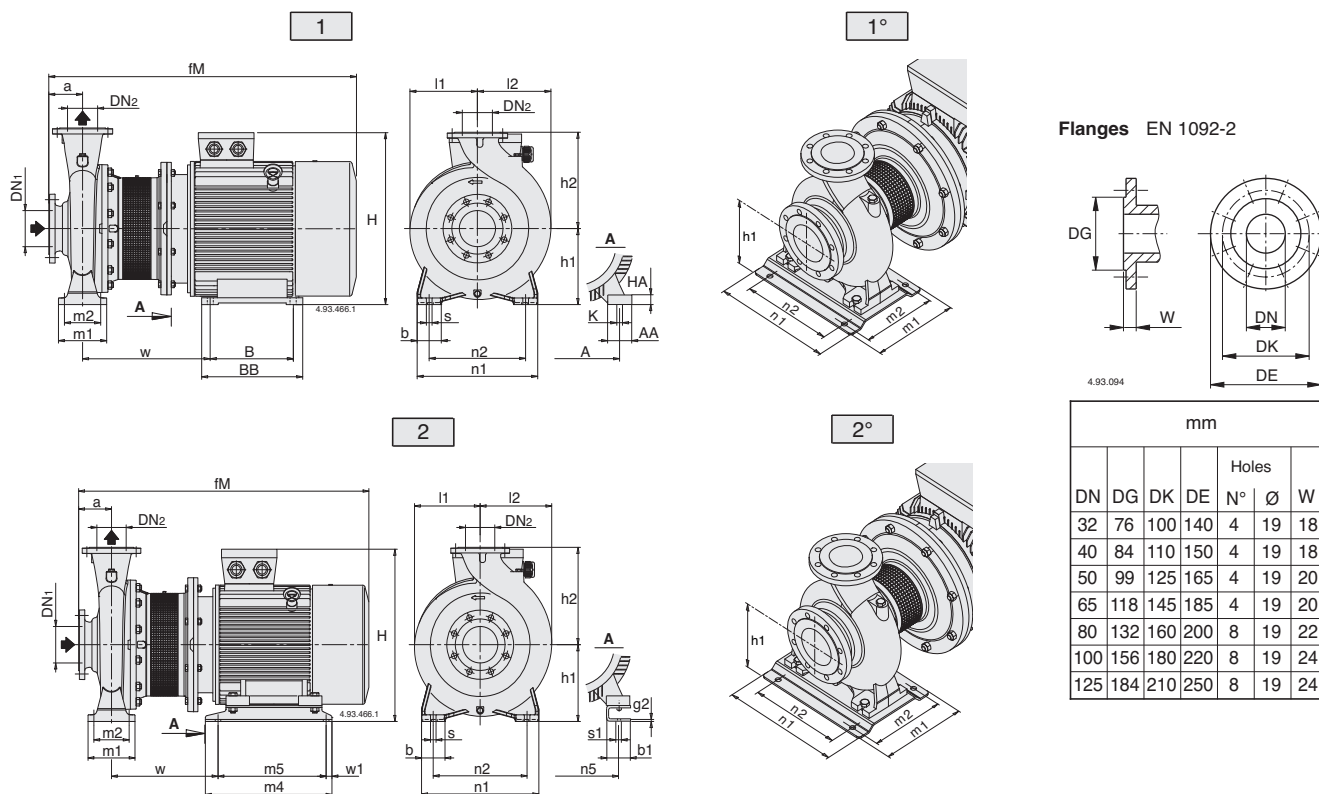

Picture	NMS	mm																												kg	
		DN1	DN2	a	fM	h1	h2	H	m1	m2	n1	n2	A	n5	w1	b	AA	b1	s	K	s1	l1	l2	w	BB	m4	B	m5	HA		g2
2	NMS 65/250B/A	80	65	100	961	200	250	486	160	120	360	280	-	279	20	80	-	70	18	-	15	179	195	333	-	440	-	400	-	20	236
1	NMS 65/250A/B	80	65	100	1009	200	250	515	160	120	360	280	318	-	-	80	70	-	18	19	-	200	200	406	355	-	305	-	25	-	321
1	NMS 80/200A	100	80	125	986	180	250	466	125	95	345	280	279	-	-	65	65	-	14	19	-	170	194	394	328	-	279	-	20	-	222
2	NMS 80/250D	100	80	125	986	200	280	486	160	120	400	315	-	279	20	80	-	70	18	-	15	191	211	333	-	440	-	400	-	20	242
1	NMS 80/250C/A	100	80	125	1034	200	280	515	160	120	400	315	318	-	-	80	70	-	18	19	-	200	210	406	355	-	305	-	25	-	345
1°	NMS 80/250B/A	100	80	125	1129	225	280	563	298	258	410	315	356	-	-	-	80	-	18	19	-	225	225	445	361	-	311	-	34	-	437
2°	NMS 80/250A/A	100	80	125	1198	280	280	690	260	220	410	315	-	406	25	-	-	100	18	-	24	275	275	443	-	500	-	450	-	8	534
2	NMS 100/200C	125	100	125	986	200	280	486	160	120	360	280	-	279	20	80	-	70	18	-	15	180	212	333	-	440	-	400	-	20	236
1	NMS 100/200B/A	125	100	125	1034	200	280	515	160	120	360	280	318	-	-	80	70	-	18	19	-	200	212	406	355	-	305	-	25	-	338
1°	NMS 100/200A/A	125	100	125	1129	225	280	563	298	258	410	315	356	-	-	-	80	-	18	19	-	225	225	445	361	-	311	-	34	-	426
2°	NMS 100/250B/A	125	100	140	1213	280	280	690	260	220	410	315	-	440	25	-	-	100	18	-	24	275	275	443	-	500	-	450	-	8	545
1°	NMS 100/250A/A	125	100	140	1286	280	280	713	260	220	410	315	457	-	-	-	100	-	18	24	-	275	275	516	479	-	368	-	40	-	648

B-NM, B-NMS

Dimensions and weights

Flanges EN 1092-2

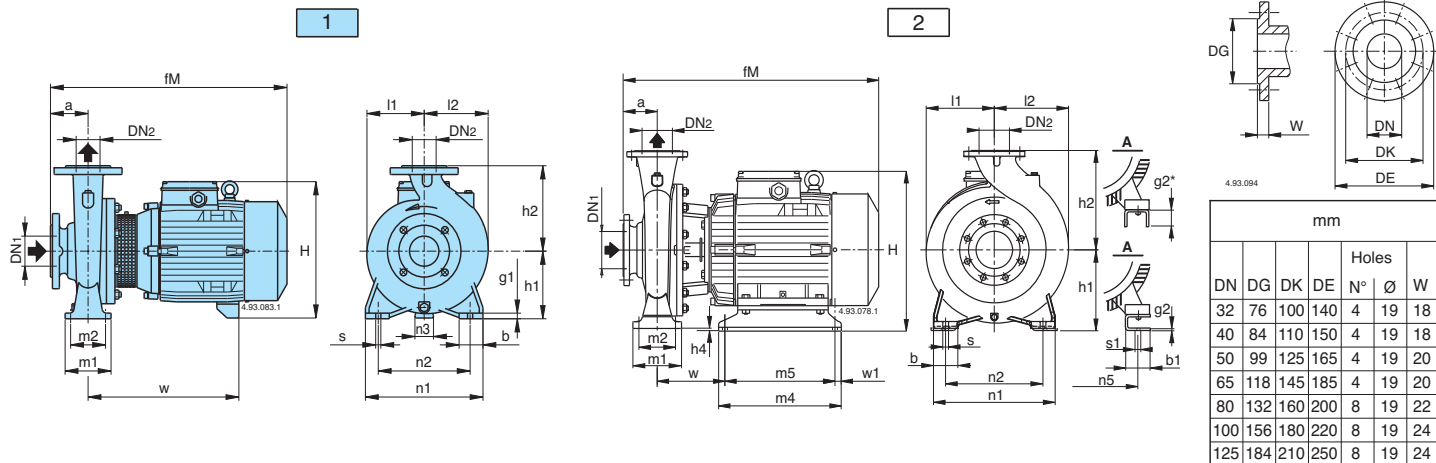

Picture	B- NM	mm																							kg			
		DN1	DN2	a	fm	h1	h2	H	h4	m1	m2	n1	n2	n3	n5	w1	b	b1	s	s1	l1	l2	w	m4	m5	g1	g2	B-NM
1	B-NM 32/12D-F B-NM 32/12S/A-A/A	50	32	80	405	112	140	240	-	100	70	190	140	37	-	-	50	-	14	-	93	97	245	-	-	12	-	27-27 30-28
	B-NM 32/16B/A B-NM 32/16A/B	50	32	80	410 450	132	160	260	-	100	70	240	190	47	-	-	50	-	14	-	120	120	250 290	-	-	12	-	38,5 42
	B-NM 32/20D/B B-NM 32/20C/A B-NM 32/20A/B	50	32	80	450 475 475	160	180	288 298 298	-	100	70	240	190	45 60 60	-	-	50	-	14	-	140	140	290 295 295	-	-	12	-	47,5 56,5 58
	B-NM 32L/16C B-NM 32L/16B/A B-NM 32L/16A/B	50	32	80	450 475 475	132	160	260 270 270	-	100	70	240	190	47 45 45	-	-	50	-	14	-	121	121	290 295 295	-	-	10	-	42,5 49,5 52,5
	B-NM 32L/20C B-NM 32L/200A-B	50	32	80	475 563	160	180	298 320	-	100	70	240	190	60 49	-	-	50	-	14	-	142	142	295 334	-	-	12	-	58,3 79,3-73,8
	B-NM 40/12C/A-F/A B-NM 40/12A/B	65	40	80	410 450	112	140	240	-	100	70	210	160	37	-	-	50	-	14	-	100	113	250 290	-	-	12	-	33-31 36
1*	B-NM 40/16C/B B-NM 40/16B/A B-NM 40/16A/B	65	40	80	450 475 475	132	160	260 270 270	-	100	70	240	190	47 45 45	-	-	50	-	14	-	121	122	290 295 295	-	-	10	-	43 50 53
	B-NM 40/20C/B-D/B B-NM 40/200A/A-AR/A-B/A	65	40	100	495 583	160	180	298 320	-	100	70	265	212	60 49	-	-	50	-	14	-	142	142	295 334	-	-	12	-	59,5-59 80,5-75
	B-NM 4025/C/C B-NM 4025/B/C B-NM 4025/A/C	65	40	100	635 685 710	192	225	377	12	125	95	320	250	-	216	20	65	69	14	12	175	175	174	298	258	-	6	124 130 159,5
1	B-NM 50/12F/B B-NM 50/12D/A B-NM 50/12A/B-S/B	65	50	100	470 495 495	132	160	260 270 270	-	100	70	240	190	47 45 45	-	-	50	-	14	-	122	137	290 295 295	-	-	10	-	44 52 54,5-54
	B-NM 50/160A/B-B/B	65	50	100	583	160	180	320	-	100	70	265	212	49	-	-	50	-	14	-	126	140	334	-	-	12	-	80-74,5
	B-NM 50/200B/C B-NM 50/200A/C B-NM 50/200S/C	65	50	100	695 745 769	192	200	377	32	100	70	265	212	-	216	20	50	69	14	12	140	153	234	298	258	-	6	123 132 154
	B-NM 5025/C/C B-NM 5025/B/C B-NM 50/25A	65	50	100	685 710 766	192	225	377	12	125	95	320	250	-	216	20	65	69	14	12	175	175	174	298	258	-	6	135 156 -
1	B-NM 65/12E/A B-NM 65/125A/B-C/B	80	65	100	500 588	160	180	298 320	-	125	95	280	212	60 49	-	-	65	-	14	-	130	154	300 339	-	-	12	-	57,3 80,5-74,5
	B-NM 65/160D/B B-NM 65/160C/C	80	65	100	583 660	160	200	320 345	-	125	95	280	212	49 40	-	-	65	-	14	-	140	179	334 430	-	-	12	-	80,2 101
2	B-NM 65/160B/C B-NM 65/160A/C-AR	80	65	100	745 770	192	200	377	32	125	95	280	212	-	216	20	65	69	14	12	140	179	234	298	258	-	6	140 152
	B-NM 65/200C/C B-NM 65/250C/B	80	65	100	775 825	192	225	377	12	125	95	320	250	-	216	20	65	69	14	12	159	179	239	298	258	-	6	160 210
	B-NM 80/160E/B B-NM 80/160D/C	100	80	125	608 685	180	225	340 365	-	125	95	320	250	60 50	-	-	65	-	14	-	153	181	334 430	-	-	12	-	89,4 109
1*	B-NM 80/160C/C B-NM 80/160B/C	100	80	125	775 800	192	225	377	12	125	95	320	250	-	216	20	65	69	14	12	153	181	239	298	258	-	6	149 161
	B-NM 80/16A	100	80	125	789	180	225	386	-	125	95	320	250	-	254	20	65	60	14	15	153	181	164	394	354	-	20*	-

* Version without coupling guard

B-NM, B-NMS

Dimensions and weights

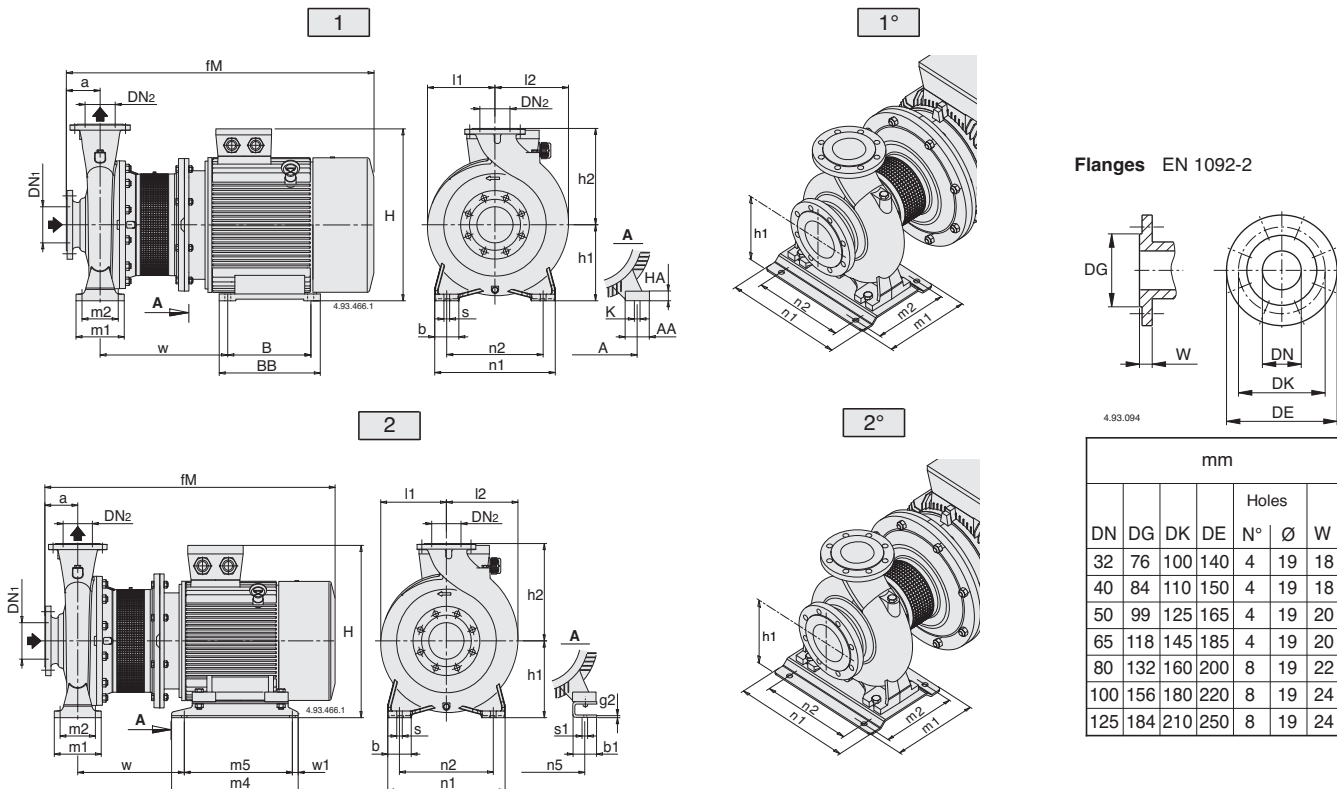

Flanges EN 1092-2

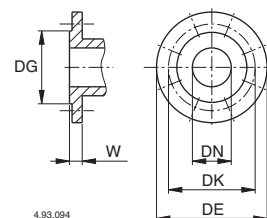

mm						
DN	DG	DK	DE	Holes		
				N°	Ø	W
32	76	100	140	4	19	18
40	84	110	150	4	19	18
50	99	125	165	4	19	20
65	118	145	185	4	19	20
80	132	160	200	8	19	22
100	156	180	220	8	19	24
125	184	210	250	8	19	24

Picture	B-NMS	mm																												kg		
		DN1	DN2	a	fM	h1	h2	H	m1	m2	n1	n2	A	n5	w1	b	AA	b1	s	K	s1	l1	l2	w	BB	m4	B	m5	HA		g2	
2	B-NMS 65/200A-B	80	65	100	864	180	225	386	125	95	320	350	-	254	20	65	-	60	14	-	15	159	179	331	-	394	-	354	-	20		
2	B-NMS 65/250B/A	80	65	100	961	200	250	486	160	120	360	280	-	279	20	80	-	70	18	-	15	179	195	333	-	440	-	400	-	20		
1	B-NMS 65/250A/B	80	65	100	1009	200	250	515	160	120	360	280	318	-	-	80	70	-	18	19	-	200	200	406	355	-	305	-	25	-	353	
2	B-NMS 80/200B/A	100	80	125	936	180	250	387	125	95	345	280	-	254	20	65	-	60	14	-	15	175	194	331	-	350	-	310	-	5		
1	B-NMS 80/200A/A	100	80	125	986	180	250	466	125	95	345	280	279	-	-	65	65	-	14	15	-	170	194	394	328	-	279	-	20	-	266	
2	B-NMS 80/250E/A	100	80	125	936	200	280	407	160	120	400	315	-	254	20	80	-	60	18	-	15	191	210	331	-	394	-	354	-	6		
2	B-NMS 80/250D/A	100	80	125	986	200	280	486	160	120	400	315	-	279	20	80	-	70	18	-	15	191	212	333	-	440	-	400	-	20	287	
1	B-NMS 80/250C/A	100	80	125	1034	200	280	515	160	120	400	315	318	-	-	80	70	-	18	19	-	200	210	406	355	-	305	-	25	-		
1°	B-NMS 80/250B/A	100	80	125	1129	225	280	563	298	258	410	315	356	-	-	-	-	80	-	18	19	-	225	225	445	361	-	311	-	34	-	
2°	B-NMS 80/250A/A	100	80	125	1198	280	280	690	260	220	410	315	-	406	25	-	-	100	18	-	24	275	275	443	-	500	-	450	-	8		
2	B-NMS 100/200D/A-E/B	125	100	125	936	200	280	407	160	120	360	280	-	254	20	80	-	60	18	-	15	180	212	331	-	394	-	354	-	6		
2	B-NMS 100/200C/A	125	100	128	1034	200	280	535	160	120	360	280	-	279	20	80	-	70	18	-	15	180	212	345	-	440	-	400	-	20		
1	B-NMS 100/200B/A	125	100	125	1034	200	280	515	160	120	360	280	318	-	-	80	70	-	18	19	-	200	212	406	355	-	305	-	25	-	352	
1°	B-NMS 100/200A/A	125	100	125	1129	225	280	563	298	258	410	315	356	-	-	-	-	80	-	18	19	-	225	225	445	361	-	311	-	34	-	
2°	B-NMS 100/250B/A	125	100	140	1213	280	280	690	260	220	410	315	-	440	25	-	-	100	18	-	24	275	275	443	-	500	-	450	-	8		
1°	B-NMS 100/250A/A	125	100	140	1286	280	280	713	260	220	410	315	457	-	-	-	-	100	-	18	24	-	275	275	516	479	-	368	-	40	-	

NM, NMS

Features

Cutting edge hydraulics

The geometry of the impeller and the pump casing are optimized to achieve maximum efficiency and the best suction capability.

Flexible

The option to choose between cast iron and bronze materials for the hydraulic parts in contact with the pumped liquid allows NM series pumps to be selected for use with different types of liquids.

Compact Design

The compact design allows for easy installation even in confined spaces.

Exclusive design

An innovative, patented guard prevents contact with rotating parts, proving protection to the end user whilst allowing for inspection of the mechanical seal.

Reliable

The bearing and shaft are designed to ensure the reduction of the stress, providing high reliability under all operating conditions.

NM

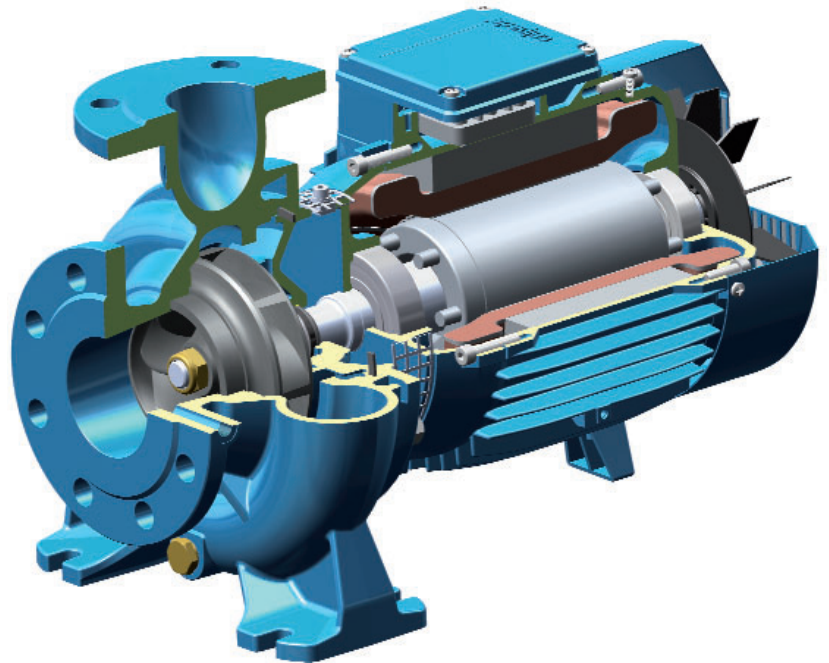

Cutting edge hydraulics

The geometry of the impeller and the pump casing are optimized to achieve maximum efficiency and the best suction capability.

Flexible

The option to choose between cast iron and bronze materials for the hydraulic parts in contact with the pumped liquid allows NMS series pumps to be selected for use with different types of liquids.

New lantern bracket construction

The lantern brackets incorporate a thrust bearing on the hydraulic side which guarantees the elimination of additional loads on the motor bearings. The flange is sized to be used with standard motors B35.

Exclusive design

An innovative, patented guard prevents contact with rotating parts, proving protection to the end user whilst allowing for inspection of the mechanical seal.

Simplified motor maintenance

The presence of the thrust bearing on the hydraulic side makes it easier to remove the motor, facilitating maintenance operations and eliminating the risks of damage to the hydraulic parts.

NMS

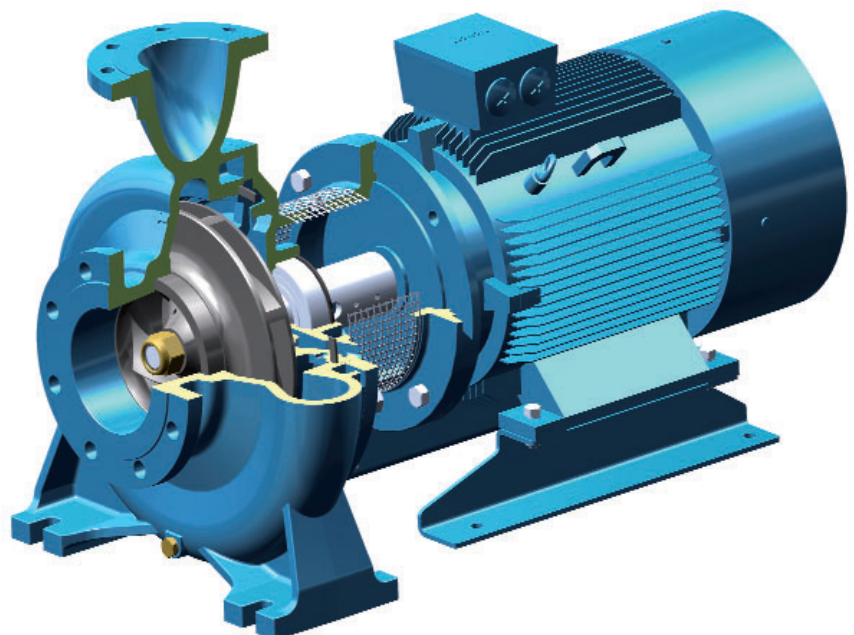

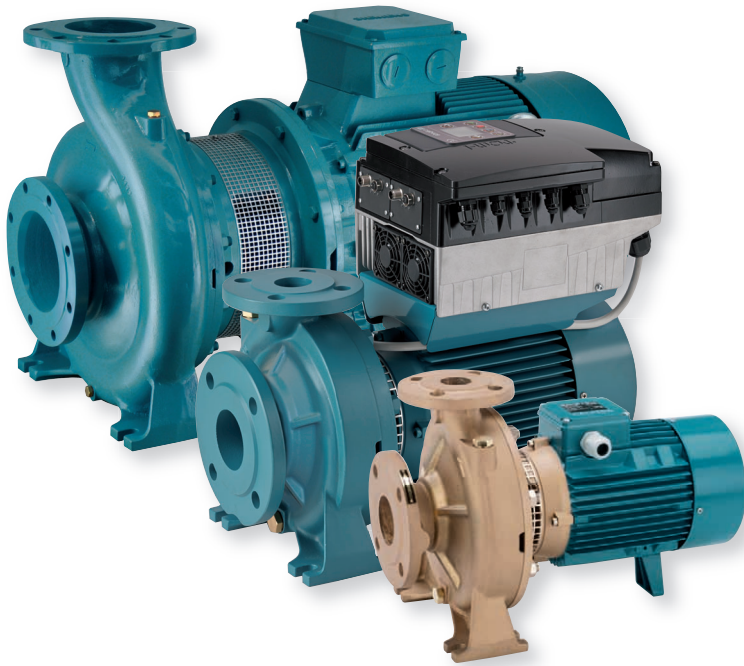

Construction

Close-coupled centrifugal pumps; electric motor with extended shaft directly connected to the pump up to 15 kW, new bracket construction for standard motors (Stub-shaft construction) from 18,5 to 75 kW with integrated thrust bearing. Pump casing with axial suction and radial delivery on top, main dimensions and performance according to EN 733 with additional sizes for completion. NM(S)4: version with pump casing and lantern bracket in cast iron. B-NM(S)4: version with pump casing and lantern bracket/casing cover in bronze. (the pumps are supplied fully painted).

Connections

Sizes	Connections
NM4 25/...	Threaded ports ISO 228
from NM4 32/.. to NMS4 150/..	Flanges according to PN 10, EN 1092-2

Counter-flanges (on request)

Sizes	Flanges
from NM4 32/.. to NM4 50/..	Screwed flanges EN 1092-1, PN 16
from NM4 32/.. to NMS4 150/..	Flanges for welding EN 1092-1, PN 10

Version with frequency converter (on request)

Applications

For clean liquids without abrasives, which are non-aggressive for the pump materials (contents of solids up to 0,2%). For water supply. For heating, air conditioning, cooling and circulation plants. For civil and industrial applications. When low noise operating is required. For irrigation.

Operating conditions

Liquid temperature from -10 °C to +90 °C.
Ambient temperature up to 40 °C.
Total suction lift up to 7 m.
Maximum permissible working pressure up to 10 bar (16 bar for NM4 40/16,20; NM4 50/16; NM4 65/16,20,25; NM(S)4 80/16,31,400; NM4 100/20).
Continuous duty.

Motor

4-pole induction motor, 50 Hz (n ≈ 1450 rpm).
NM4, NMS4: three-phase 230/400 V ± 10% up to 3 kW;
400/690 V ± 10% from 4 to 75 kW.
Insulation class F. Protection IP 54 (IP 55 for NMS4).
Motor suitable for operation with frequency converter from 0,75 kW.
Classification scheme IE3 for three-phase motors from 0,75 kW.
Constructed in accordance with: EN 60034-1; EN 60034-30-1.

Special features on request

- Other voltages. - Frequency 60 Hz (as per 60 Hz data sheet).
- Protection IP 55. - Special mechanical seal.
- Higher or lower liquid or ambient temperatures.
- Motor suitable for operation with frequency converter up to 0,55 kW.

The electropumps NM4, B-NM4, NMS4, B-NMS4 series comply with the European Regulation no. 547/2012.

Materiali

Components	NM4, NMS4	B-NM4, B-NMS4
Pump casing	Cast iron	Bronze
Lantern bracket NM4	GJL 200 EN 1561	G-Cu Sn 10 EN 1982
Casing cover for NMS4		
Lantern bracket NMS4	Cast iron GJL 200 EN 1561	
Impeller	Cast iron	Bronze
	GJL 200 EN 1561	G-Cu Sn 10 EN 1982
	Brass P-Cu Zn 40 Pb 2 UNI 5705	
	For NM4 25/125 - 25/160 - 25/200 - NM4 32/16 - 32/20 - 40/20	
Shaft	Cr-Ni steel AISI 303	Cr Ni Mo steel
	AISI 430 from 1,5 kW to 15 kW	AISI 316
Mechanical seal	Carbon - Ceramic - NBR	
Counter-flanges	Steel Fe 430B UNI 7070	

Coverage chart n ≈ 1450 rpm

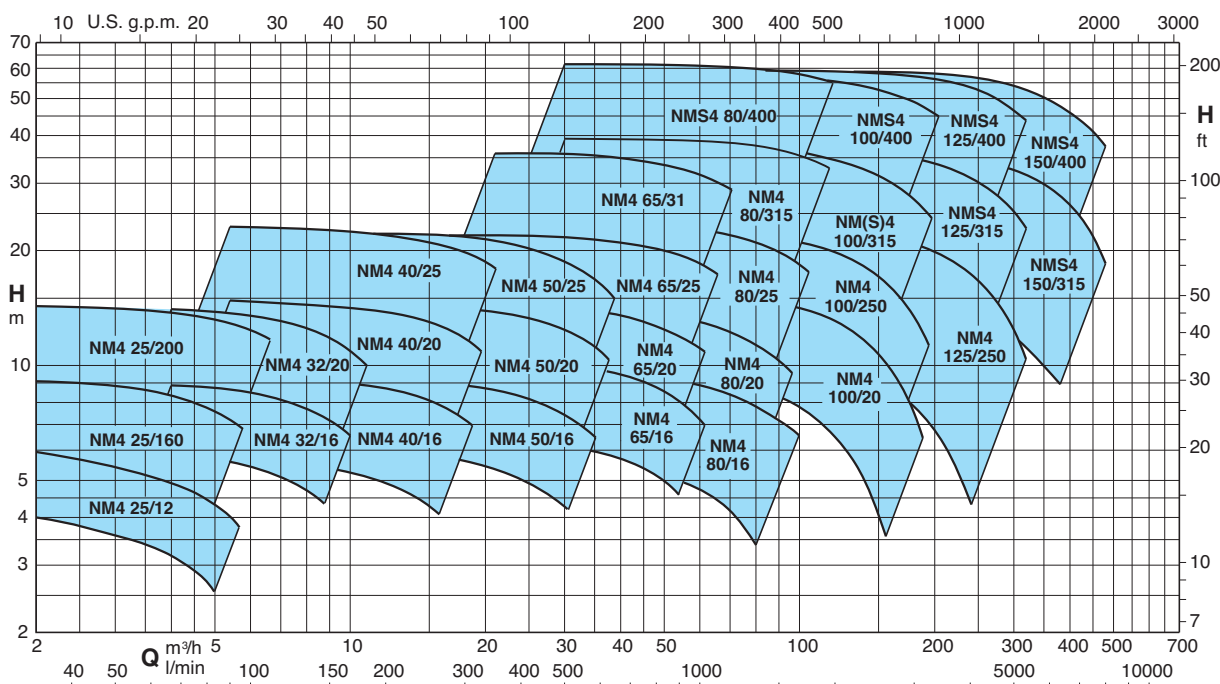

Pumps with frequency converter

The **NM4 EI** pumps are available with power from 0,25 kW up to 15 kW, the pumps are equipped with **I-MAT** installed on board which allows to realize a variable-speed system extremely compact and efficient, ideal in applications of water supply and in the distribution of hot and cold water.

The pump is equipped with transducers suitable for operation and is already programmed at the factory.

Advantages

- Energy saving
- Compact design
- Easy to use
- Programmable to suit the system requirements
- Reliability

Costruction

The system comprises of:

- Pump
- Induction motor
- I-MAT Frequency converter
- Motor adapter for the motor mounting of the frequency converter
- Connection cable between frequency converter and induction motor
- Transducers

Main features

- Rated motor power output from 0,25 kW to 15 kW
- Control range from 870 to 1450 rpm (4-pole)
- Protection against dry running
- Protection against operations with closed valve ports
- Protection against system leakages
- Protection against overcurrent in the motor
- Protection agains overvoltage and undervoltage of the power supply
- Protection against current unbalances between phases



Operating modes



Constant pressure mode
with pressure transducer

In this mode, the system maintains the preset pressure when the flow required by the installation changes.

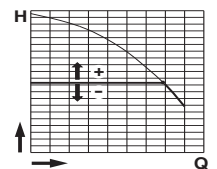

Proportional pressure mode
with pressure transducer

In this mode the system changes the working pressure according to the required flow rate.

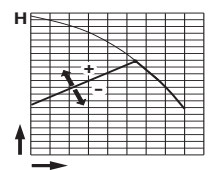

Constant flow mode
with flow meter

In this mode the system maintains a constant flow rate value in a point of the installation according to the required pressure.

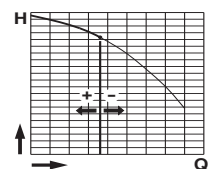

Fixed speed mode
with setting of the speed preferential rotation.

In this mode, by changing the working frequency, you may choose any operational curve included within the working range.

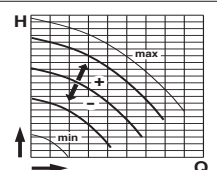

Constant temperature mode
with temperature transducer

In this mode the system keeps the temperature constant inside a system by changing the speed of the pump.

Performance n ≈ 1450 rpm

B - NM4	NM4	P ₂		Q m ³ /h l/min	1	1,2	1,5	1,89	2,4	3	3,6	4,2	4,8	5,4	6	6,6	7,5	8,4	9,6	10,8	12	13,2	15	
		kW	HP		16	20	25	31,5	40	50	60	70	80	90	100	110	125	140	160	180	200	220	250	
B- NM4 25/160BE	NM4 25/12A/A	0,25	0,34	H m	6,1	6,05	6	5,9	5,8	5,5	5,2	4,8	4,4	3,9	3,3									
B- NM4 25/160AE	NM4 25/160BE	0,37	0,5		7,7	7,65	7,6	7,55	7,5	7,2	6,9	6,6	6,1	5,5	4,6	3,6								
B- NM4 25/200C/A	NM4 25/200C/A	0,37	0,5		9,2	9,15	9,1	9,05	9	8,7	8,5	8,2	7,8	7,2	6,5	5,6	3,7							
B- NM4 25/200B/A	NM4 25/200B/A	0,55	0,75		11,5	11,4	11,4	11,3	11,2	11,1	10,9	10,7	10,5	10,2	9,8	9,4	8,6	7,7	6	3,6				
B- NM4 25/200A/C	NM4 25/200A/C	0,75	1		13,2	13,2	13,2	13,1	13,1	13	12,9	12,7	12,5	12,3	11,9	11,5	11,0	10,3	8,9	6,9	4,1			
					14,5	14,5	14,5	14,5	14,5	14,4	14,3	14,2	14	13,8	13,5	13,2	12,7	12,1	11	9,2	6,8	2,9		

B - NM4	NM4	P ₂		Q m ³ /h l/min	2,4	3	3,6	4,8	5,4	6	7,5	8,4	9,6	10,8	12	13,2	15	16,8	18,9	21	24	27	30	
		kW	HP		40	50	60	80	90	100	125	140	160	180	200	220	250	280	315	350	400	450	500	
B-NM4 32/16B	NM4 32/16BE	0,37	0,5	H m	7,6	7,5	7,4	7,2	7,1	6,9	6,3	5,9	5,2	4,2										
B-NM4 32/16A	NM4 32/16AE	0,37	0,5		9	8,95	8,9	8,7	8,6	8,5	7,9	7,5	6,8	6	5,1									
B-NM4 32/20B	NM4 32/20BE	0,55	0,75		12,5	12,4	12,3	12	11,8	11,6	10,6	10	8,9	7,6	6,2	4,7								
B-NM4 32/20A/B	NM4 32/20A/B	0,75	1		14,3	14,2	14,1	13,9	13,7	13,5	12,9	12,3	11,3	10,2	8,9	7,5								
B-NM4 40/16C	NM4 40/16C/A	0,37	0,5						6,1	6	5,9	5,8	5,6	5,4	5,2	5	4,5	3,9	3,1	2,3				
B-NM4 40/16B	NM4 40/16B/A	0,55	0,75						7,6	7,6	7,6	7,6	7,3	7,1	6,9	6,6	6,3	5,7	5	4	2,7			
B-NM4 40/16A/B	NM4 40/16A/C	0,75	1						9,6	9,6	9,6	9,4	9,3	9,1	9	8,8	8,4	7,9	7,2	6,4	5,1	3,5		
B-NM4 40/20B/B	NM4 40/20B/B	1,1	1,5						13	12,9	12,7	12,6	12,4	12,2	12	11,5	10,8	10	8,6	7				
B-NM4 40/20A/B	NM4 40/20A/B	1,1	1,5						14,8	14,7	14,5	14,4	14,2	14	13,8	13,6	13	12,2	11,3	10				
B-NM4 40/25C/C	NM4 40/25C/C	1,5	2						17,4	17,3	17,2	17	16,8	16,6	16,3	16	15,1	13,8	12,1	10,4	7,2	2,8		
B-NM4 40/25B/C	NM4 40/25B/C	2,2	3						21,4	21,5	21,3	21,2	21	20,9	20,8	20,5	20	19,5	18,3	16,4	13,3	10	5	
B-NM4 40/25A/B	NM4 40/25A/B	3	4						22,9	22,8	22,9	22,8	22,5	22,5	22,2	22	21,8	21,4	20,4	18,9	16	12,6	8	

B - NM4	NM4	P ₂		Q m ³ /h l/min	10,8	12	13,2	15	16,8	18,9	21	24	27	30	33	37,8	42	48	54	60	66	75	84	96
		kW	HP		180	200	220	250	280	315	350	400	450	500	550	630	700	800	900	1000	1100	1250	1400	1600
B-NM4 50/16B/B	NM4 50/16B/C	1,1	1,5	H m	8,2	8,2	8,2	8,1	8	7,8	7,6	7,2	6,7	6,2	5,5	4,4	3,3							
B-NM4 50/16A/B	NM4 50/16A/C	1,1	1,5		9,6	9,6	9,6	9,5	9,5	9,3	9,1	8,8	8,3	7,8	7,2	6,1	4,9	3,1						
	NM4 50/20C/C	1,1	1,5		11,8	11,8	11,7	11,7	11,5	11,3	10,9	10,4	9,8	9	8,1	6,3	4,7							
	NM4 50/20B/C	1,5	2		13,4	13,4	13,4	13,3	13,1	12,9	12,6	12,1	11,5	10,8	9,9	8,2	6,4	3,7						
	NM4 50/20A/C	2,2	3		14,9	14,9	14,9	14,9	14,8	14,6	14,4	14	13,4	12,8	12	10,4	8,6	6						
B-NM4 50/25D/B	NM4 50/25D/B	2,2	3		17,8	17,8	17,7	17,5	17,2	16,8	16,4	15,7	14,9	13,8	12,4	9,7	6,8							
B-NM4 50/25C/C	NM4 50/25C/C	2,2	3		20,7	20,7	20,7	20,6	20,4	20	19,5	18,9	18,2	17,1	15,9	13,2	10,6	5,8						
B-NM4 50/25B/B	NM4 50/25B/B	3	4		22,7	22,7	22,6	22,5	22,4	22,1	21,6	21	20,2	19,4	18,3	16,4	13,6	9						
B-NM4 50/25A/B	NM4 50/25A/B	4	5,5								6,1	6,1	6	5,9	5,8	5,6	5,3	4,8	4,2					
B-NM4 65/16C/C	NM4 65/16C/C	1,1	1,5								7,2	7,1	7,1	7	6,8	6,6	6,3	5,8	5,2	4,5				
B-NM4 65/16B/C	NM4 65/16B/C	1,1	1,5								8,8	8,8	8,7	8,7	8,6	8,5	8,3	8	7,6	7,1	6,4	5,2		
B-NM4 65/16A/C	NM4 65/16A/C	1,5	2								10,2	10,2	10,1	10,1	10	9,9	9,7	9,4	9,1	8,6	8	7	5,7	
B-NM4 65/16S/A	NM4 65/16S/A	2,2	3								11,7	11,7	11,6	11,6	11,5	11,3	11,0	10,6	10,1	9,5	8,7	7,4	5,8	3,3
B-NM4 65/20B/A	NM4 65/20A/B	3	4								14,2	14,2	14,2	14,1	14,1	13,9	13,7	13,4	13,0	12,5	11,8	10,7	9,3	7
B-NM4 65/25B/B	NM4 65/25B/B	4	5,5								17,9	18	18	18	18	17,8	17,5	17	16,3	15,4	14,4	12,5	10,4	7
B-NM4 65/25A/C	NM4 65/25A/C	5,5	7,5								22,2	22,3	22,4	22,4	22,4	22,2	22	21,6	21	20,2	19,3	17,6	15,7	12,6
B-NM4 65/31C/B	NM4 65/31C/B	5,5	7,5								25,8	25,7	25,5	25,3	25	24,4	23,8	22,8	21,5	20	18,2	15	11	
B-NM4 65/31B/B	NM4 65/31B/B	7,5	10								31	31	30,9	30,8	30,6	30,2	29,7	28,8	27,8	26,5	25	22,2	18,6	
B-NM4 65/31A/B	NM4 65/31A/B	9,2	12,5								35,9	35,9	35,8	35,7	35,5	35,1	34,6	33,8	32,8	31,6	30,2	27,8	25	

B-NMS4	NM4 - NMS4	P ₂		Q m ³ /h l/min	30	33	37,8	42	48	54	60	66	75	84	96	108	120	132	150	168	180	192	210	
		kW	HP		500	550	630	700	800	900	1000	1100	1250	1400	1600	1800	2000	2200	2500	2800	3000	3200	3500	
	NM4 80/16C/C	1,1	1,5	H m	6,1	6,1	5,9	5,8	5,5	5,2	4,9	4,6	4	3,3										
	NM4 80/16B/C	1,5	2		7,8	7,7	7,6	7,5	7,3	7	6,8	6,4	5,9	5,2	4,1									
	NM4 80/16A/C	2,2	3		10	10	9,9	9,8	9,7	9,5	9,3	9	8,5	8	7	5,9								
B- NM4 80/20C	NM4 80/20C/B	2,2	3		10,3	10,2	10,1	10	9,8	9,5	9,1	8,6	7,7	6,6	4,6									
B- NM4 80/20B	NM4 80/20B/A	3	4		12,1	12	11,9	11,8	11,7	11,4	11,1	10,6	9,8	9	7,5	5,7								
B- NM4 80/20A	NM4 80/20A/A	4	5,5		13,9	13,8	13,7	13,6	13,5	13,3	13	12,6	11,8	11	9,6	7,9	6							
B- NM4 80/25C	NM4 80/25C/A	4	5,5		16,9	16,8	16,7	16,6	16,3	15,9	15,4	14,8	13,9	12,7	11,1	9,3	7,2							
B- NMS4 80/250B/A	NM4 80/25B/B	5,5	7,5		20,7	20,6	20,5	20,4	20,3	20	19,6	19,1	18,2	17,1	15,4	13,5	11,4	9*						
B- NMS4 80/250A/A	NM4 80/25A/B	7,5	10		23,7	23,7	23,6	23,5	23,3	23	22,7	22,2	21,5	20,5	19	17,2	15,1	12,7*						
B- NM4 80/31C/B	NM4 80/31C/B	9,2	12,5		25,7	25,8	25,8	25,8	25,8	25,6	25,4	25	24,4	23,6	22,2	20,4	18,3	15,9						
B- NMS4 80/315B/B	NM4 80/31B	11	15		30,3	30,5	30,6	30,7	30,7	30,7	30,5	30,2	29,6	28,8	27,5	25,9	24,1	22						
B- NMS4 80/315A/B	NM4 80/31A	15	20		36,3	36,4	36,5	36,6	36,6	36,5	36,4	36,1	35,6	35	33,9	32,5	30,9	29	25,3					
B- NMS4 80/315S	NMS4 80/315S	18,5	25		39,1	39,2	39,3	39,4	39,5	39,4	39,3	39,2	38,7	38,1	37,1	35,7	34,1	32,1	28,3	22,5*				
B- NMS4 80/400C/B	NMS4 80/400C/B	18,5	25		42,8	42,8	42,8	42,8	42,7	42,5	42,2	41,8	41	39,8	37,9	35,4	32,4	29,1						
B- NMS4 80/400B/B	NMS4 80/400B/B	22	30		48,2	48,2	48,2	48,2	48,1	47,9	47,7	47,3	46,6	45,7	44,1	42,1	39,5	36,3	30,5					
B- NMS4 80/400A/B	NMS4 80/400A/B	30	40		61,4	61,5	61,5	61,6	61,6	61,5	61,3	61,1	60,7	60,1	59	57,6	55,8	53,7	49,5					

Performance n ≈ 1450 rpm

B-NMS4	NM4 - NMS4	P ₂		Q m ³ /h l/min	Head (m)																		
		kW	HP		48	54	60	66	75	84	96	108	120	132	150	168	180	192	210	240	270	300	330
B- NM4 100/20C/A	NM4 100/20C/A	3	4	9,4	9,3	9,2	9,1	8,9	8,5	8	7,3	6,5	5,6	4									
B- NM4 100/20B/A	NM4 100/20B/A	4	5,5	12	11,9	11,8	11,7	11,5	11,2	10,7	10	9,3	8,4	6,7	4,5								
B- NM4 100/20A/C	NM4 100/20A/C	5,5	7,5	15,2	15,2	15,1	15	14,9	14,7	14,3	13,8	13,1	12,2	10,7	9	7,5*	6*						
B- NMS4 100/250B/A	NM4 100/25B/B	7,5	10	19,5	19,5	19,4	19,3	19	18,7	18,2	17,5	16,6	15,6	13,8	11,7	10	8,4	5,5					
B- NMS4 100/250A/A	NM4 100/25A/B	9,2	12,5	22,3	22,3	22,2	22,1	21,9	21,7	21,2	20,5	19,8	18,8	17,1	15	13,4	11,7	8,9					
B- NMS4 100/315C/A	NM4 100/31C	11	15	26,9	26,9	26,8	26,6	26,2	25,7	24,9	23,8	22,7	21,3	18,9	15,9	13,7	11,3*						
B- NMS4 100/315B/A	NM4 100/31B	15	20	31,5	31,5	31,4	31,3	31,2	30,8	30,2	29,3	28,2	26,9	24,6	21,8	19,8	17,6*	14*					
B- NMS4 100/315A/A	NMS4 100/315A/A	18,5	25	36,9	36,9	36,8	36,7	36,6	36,4	36	35,3	34,5	33,4	31,4	29	27,2	25,3*	22,2*					
B- NMS4 100/400C/A	NMS4 100/400C/A	22	30	41,3	41,2	41,1	41	40,7	40,4	39,8	39	38	36,5	34	31	28,7	26						
B- NMS4 100/400B/A	NMS4 100/400B/A	30	40	50,2	50,1	50	49,9	49,7	49,4	48,8	48	47,1	46	44	41,3	39,5	37	33,5*					
B- NMS4 100/400A/A	NMS4 100/400A/A	37	50	58,2	58,1	58	57,9	57,8	57,6	57,2	56,3	55,7	54,5	52,7	50,5	49	47	44*					

B-NMS4	NM4 - NMS4	P ₂		Q m ³ /h l/min	Head (m)																		
		kW	HP		84	96	108	120	132	150	168	180	192	210	240	270	300	330	360	390	420	450	480
B- NMS4 125/250E/A	NM4 125/25E/B	5,5	7,5	11	10,8	10,5	10,1	9,7	9,1	8,3	7,8	7,2	6,2	4,4									
B- NMS4 125/250D/A	NM4 125/25D/B	7,5	10	14	13,9	13,7	13,4	13	12,4	11,6	11	10,4	9,4	7,4	5,1								
B- NMS4 125/250C/A	NM4 125/25C/B	9,2	12,5	16,7	16,6	16,4	16,2	15,9	15,4	14,6	14,1	13,5	12,5	10,4	8,2	5,8							
B- NMS4 125/250B/A	NM4 125/25B	11	15	19,3	19,2	19,1	18,9	18,7	18,2	17,5	17	16,3	15,3	13,3	10,9	8,2							
B- NMS4 125/315C/A	NM4 125/315C/A	18,5	25	27,9	27,7	27,6	27,2	26,5	25,6	24,9	24	22,8	20,2	17	13,5	9,5*							
B- NMS4 125/315B/A	NMS4 125/315B/A	22	30	31,8	31,7	31,6	31,5	31,1	30,6	29,7	29,1	28,5	27,3	24,9	22	18,5	14,3*						
B- NMS4 125/315A/A	NMS4 125/315A/A	30	40	36,8	36,8	36,7	36,6	36,4	35,9	35,2	34,7	34,2	33,2	31	28,4	25,3	21,6*						
B- NMS4 125/400C/A	NMS4 125/400C/A	37	50	45,4	45,3	45,2	45,1	44,9	44,4	43,7	43	42	40	37	33	28,5*	23,5*						
B- NMS4 125/400B/A	NMS4 125/400B/A	45	60	51,4	51,3	51,2	51,1	50,9	50,4	49,7	49	48,2	46,8	44	40,5	36*	31,5*						
B- NMS4 125/400A/A	NMS4 125/400A/A	55	75	59,2	59,1	59	58,9	58,7	58,2	57,7	57,2	56,7	55,7	53,5	50,5	46,5*	42,5*						
B- NMS4 150/315D/A	NMS4 150/315D/A	18,5	25					22,8	22,6	22,3	22	21,7	21,1	20	18,6	17	15,1	13	10,6	8*			
B- NMS4 150/315C/A	NMS4 150/315C/A	22	30					25,6	25,4	25,1	24,9	24,7	24,2	23,3	22	20,4	18,5	16,5	14,1	11,6*	8,9*		
B- NMS4 150/315B/A	NMS4 150/315B/A	30	40					30,6	30,6	30,5	30,3	30,1	29,7	29	27,9	26,5	24,9	23	20,8	18,3*	15,4*		
B- NMS4 150/315A/A	NMS4 150/315A/A	37	50					35,6	35,6	35,5	35,4	35,3	35,2	34,6	33,7	32,5	31	29,2	27,1	24,7*	21,8*	18,5*	
B- NMS4 150/400C/A	NMS4 150/400C/A	45	60					45	44,9	44,7	44,5	44	43,5	42,5	40,5	38,5	36	33,5	30,5	27*	23,5*	19,5*	
B- NMS4 150/400B/A	NMS4 150/400B/A	55	75					50,8	50,7	50,5	50,3	50	49,5	48,5	47	45	43	40,5	38	35*	32*	28,5*	
B- NMS4 150/400A/A	NMS4 150/400A/A	75	100					58,8	58,7	58,6	58,5	58,3	57,9	57	55,5	54	52	49,5	47	44*	41*	37,5	

NM4, NMS4 Standard construction.
B-NM4, B-NMS4 Bronze construction.

P₂ Rated motor power output.
H Total head in m.

* Maximum suction lift 1-2 m.
Tolerances according to UNI EN ISO 9906:2012

تهران، کیلومتر ۲۱ بزرگراه لشگری (جاده مخصوص کرج)، روبروی پالایشگاه نفت پارس، پلاک ۱۲ | Fax: ۰۲۱ - ۴۴۹۹۴۶۴۲ | Tel: ۰۲۱ - ۴۸۰۰۰۰۴۹

www.famcocorp.com

E-mail: info@famcocorp.com

Rated currents

P ₂		230 V Δ / 400 V Y		
kW	HP	In A	In A	IA/In
0,25	0,34	1,4	0,8	3,7
0,37	0,5	1,65	0,95	4,2
0,55	0,75	2,6	1,5	4,8
0,75	1	3,3	1,9	7,2
1,1	1,5	5	2,9	6,6
1,5	2	6	3,5	8,3
2,2	3	8,6	5	8,6
3	4	11,1	6,4	5,8

P ₂		400 V Δ / 690 V Y		
kW	HP	In A	In A	IA/In
4	5,5	8,3	4,8	7,2
5,5	7,5	12,5	7,2	7,2
7,5	10	16	9,2	7,1
9,2	12,5	20,5	11,8	7,4
11	15	22,5	13	9,6
15	20	29	16,7	9,1
18,5	25	35	20,5	7,2
22	30	41	24	6,8
30	40	55	32	7,3
37	50	66	38,5	6,4
45	60	80	46,5	6,4
55	75	96	56	6,8
75	100	133	77	6,9

P₂ Rated motor power output.
IA/In D.O.L. starting current / Nominal current

Characteristic curves $n \approx 1450$ rpm

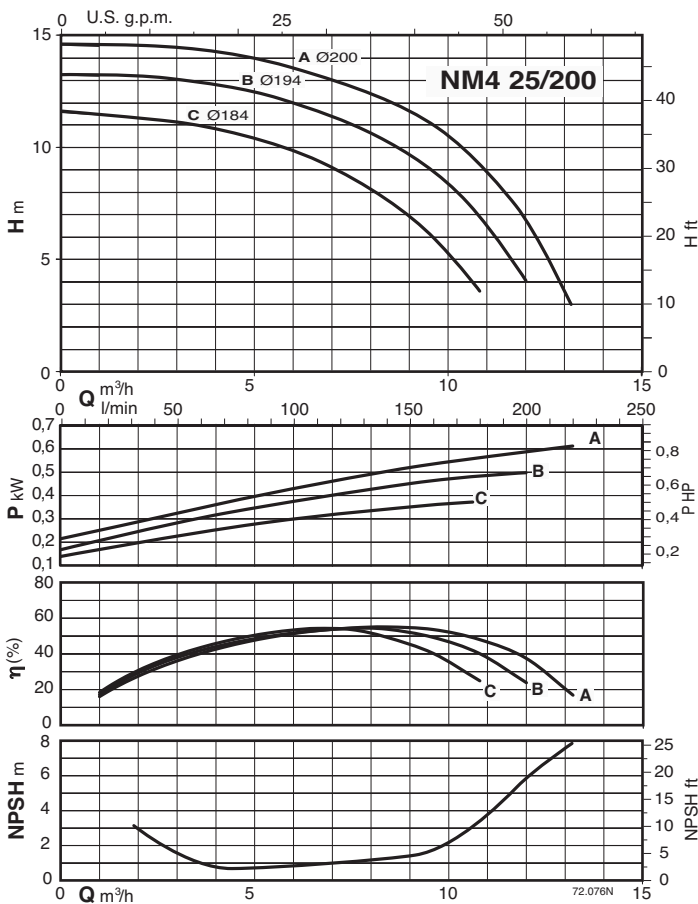
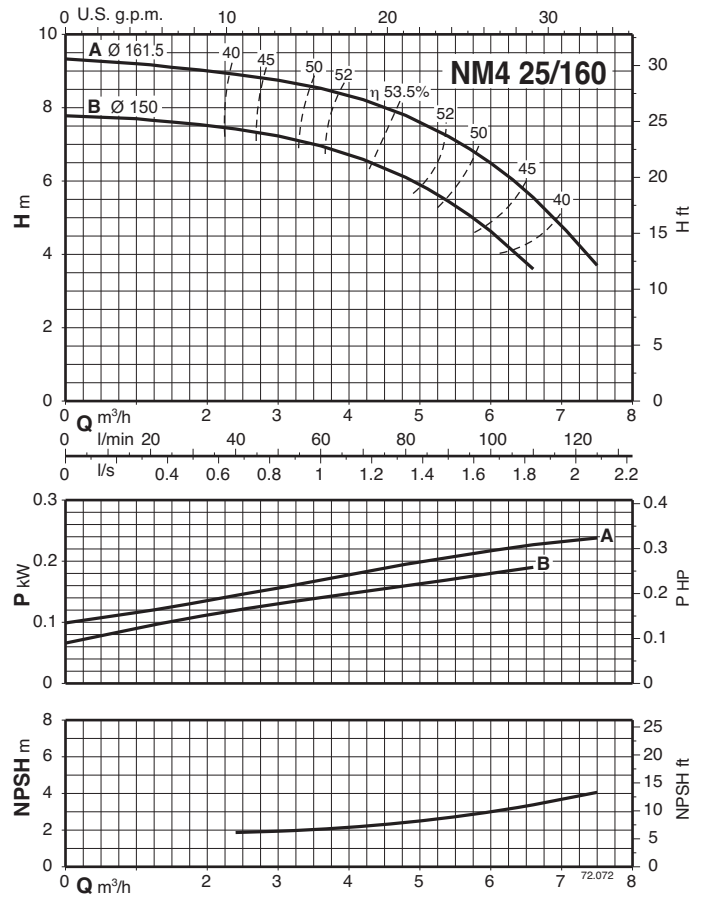
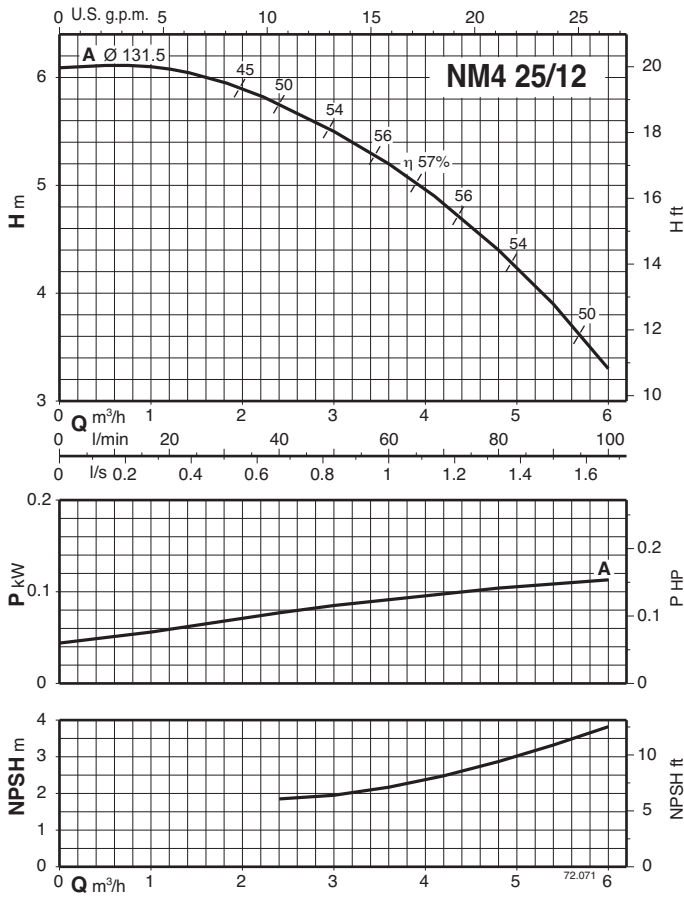

Characteristic curves $n \approx 1450$ rpm

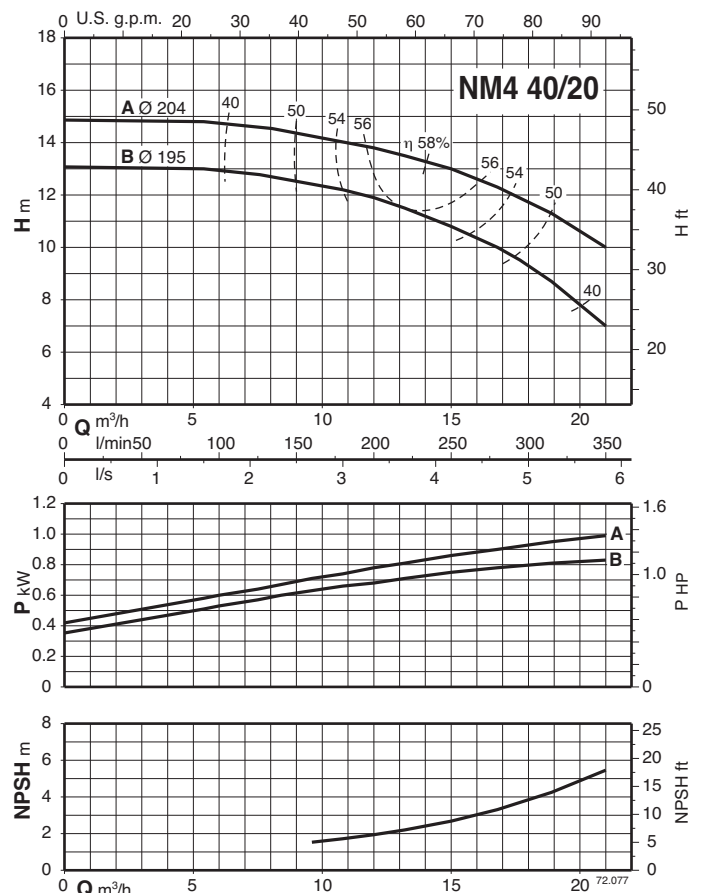
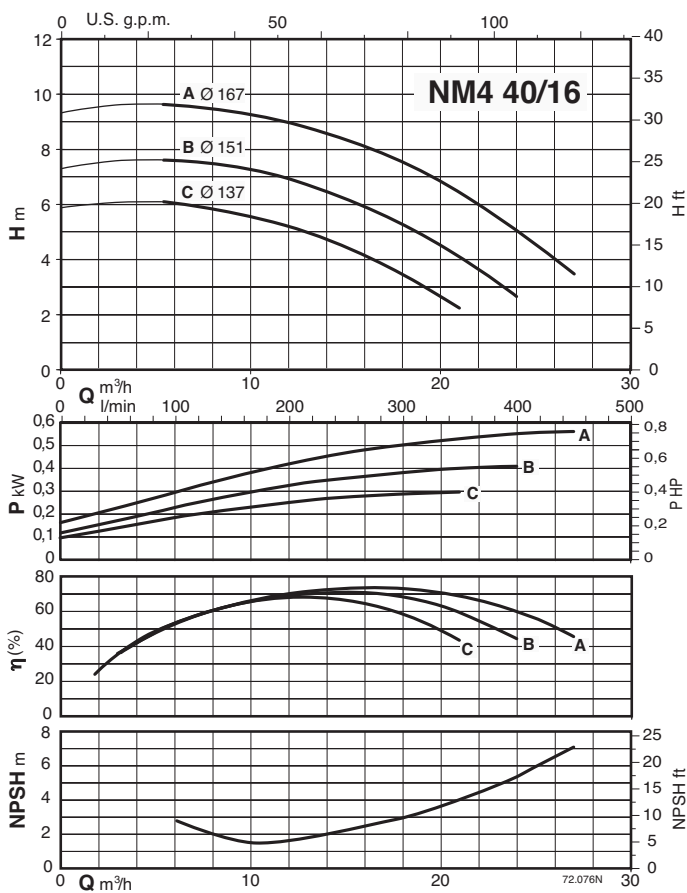
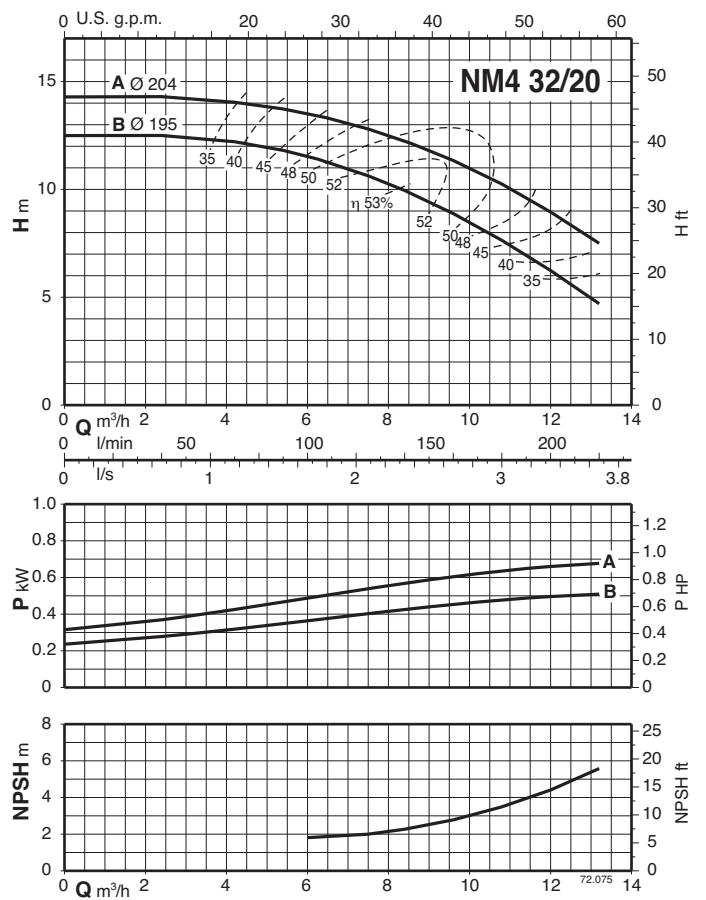
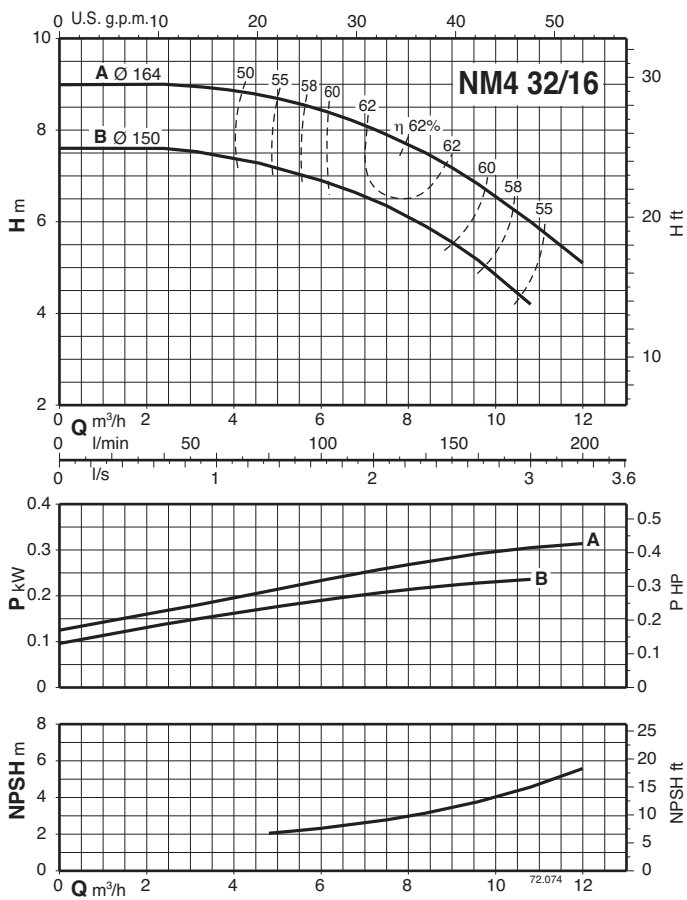

Characteristic curves $n \approx 1450$ rpm

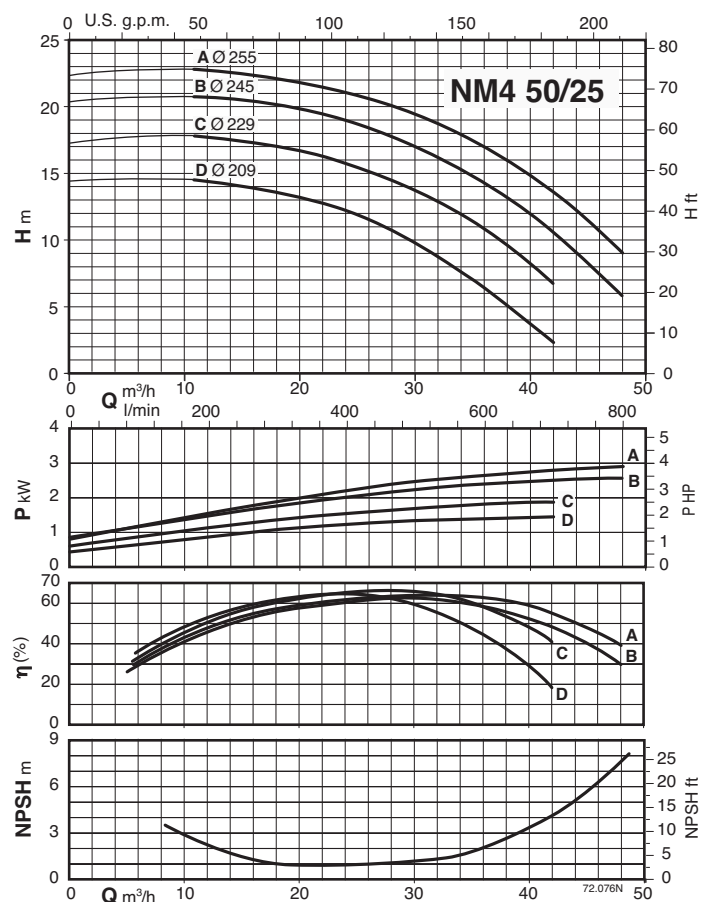
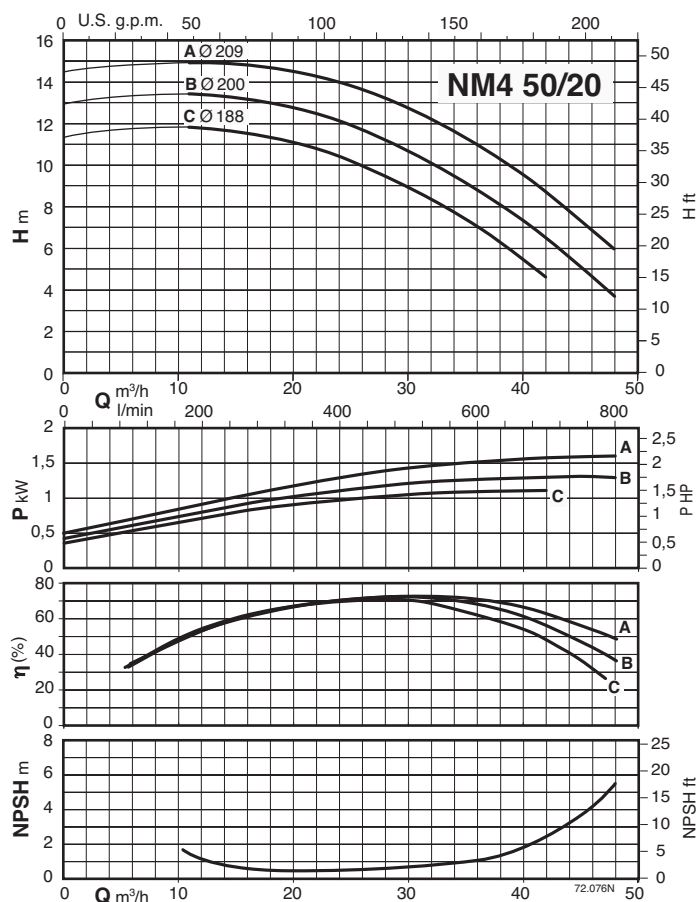
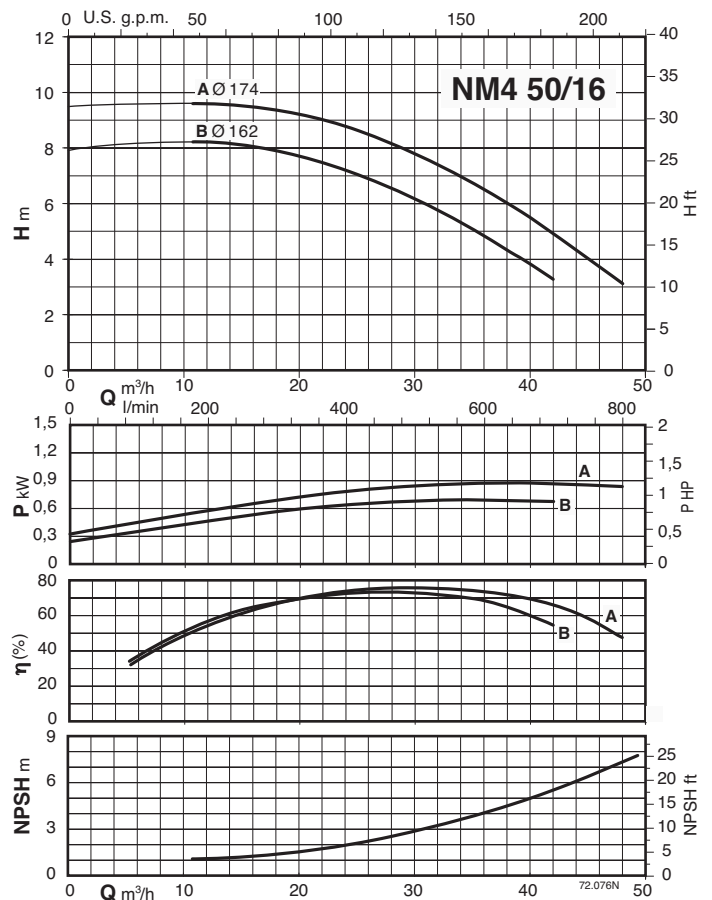
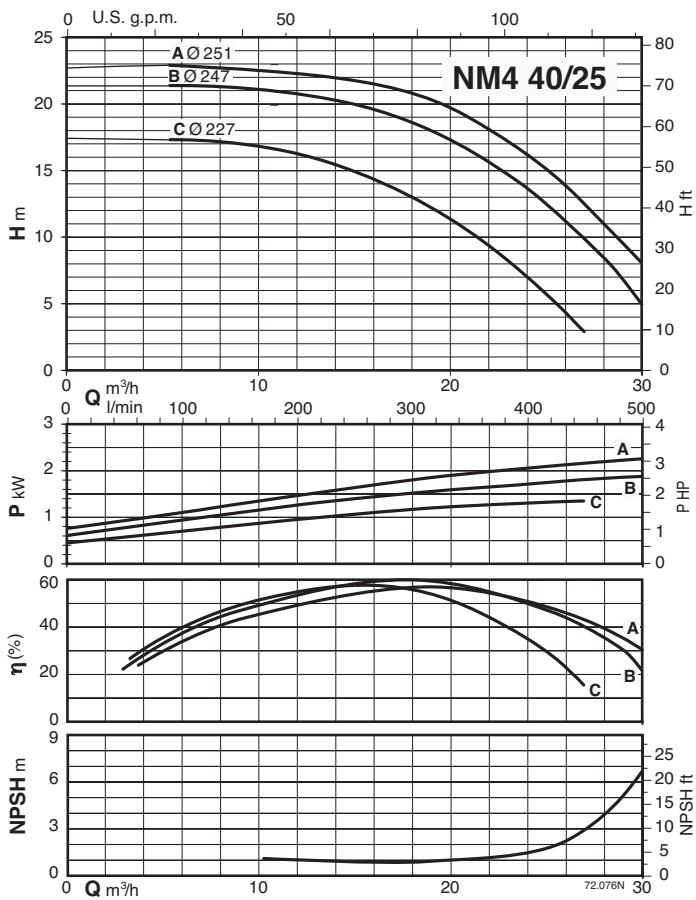

Characteristic curves $n \approx 1450$ rpm

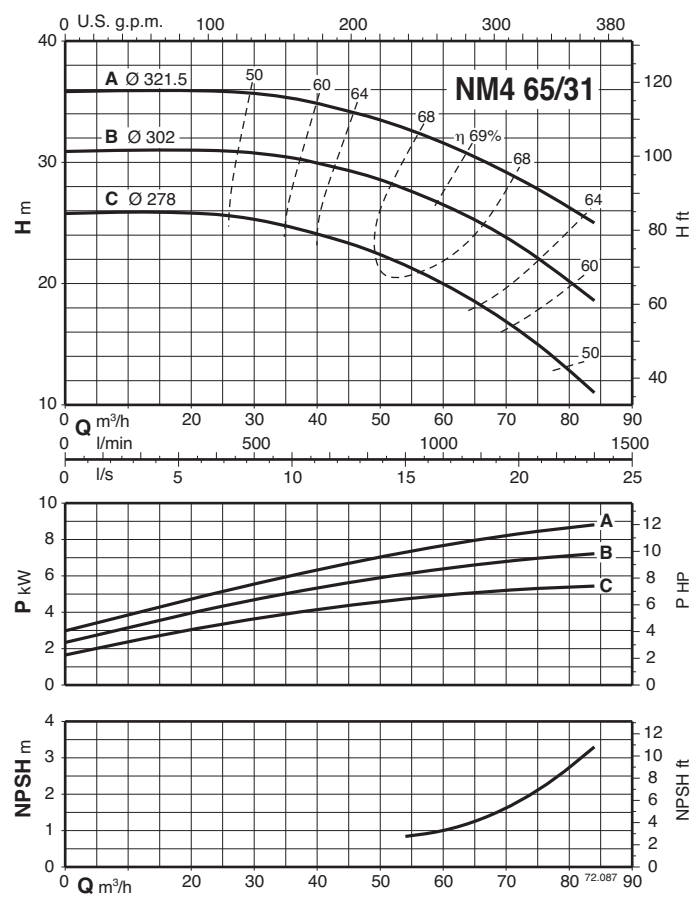
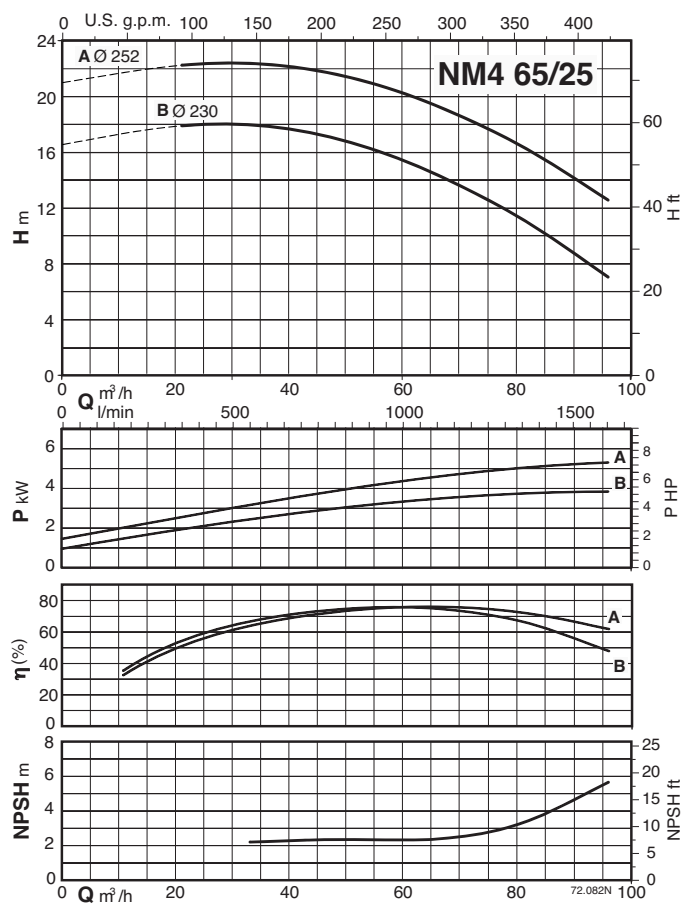
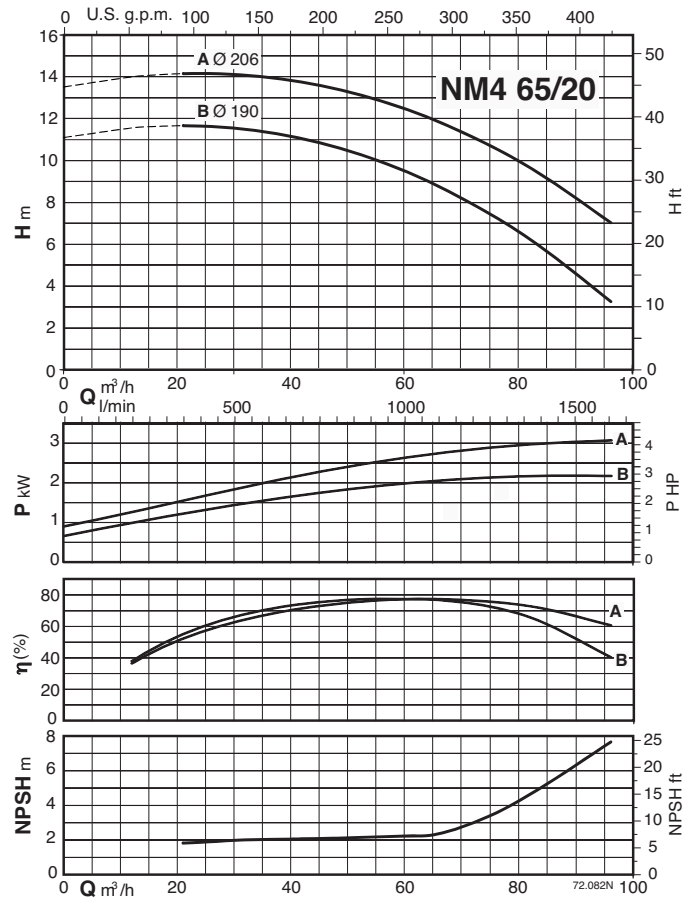
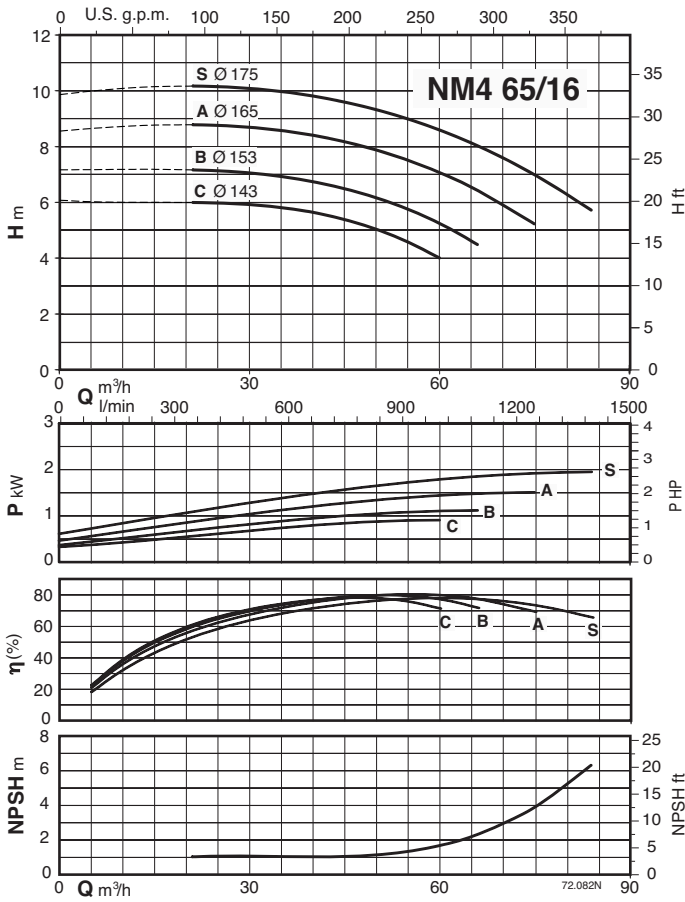

Characteristic curves $n \approx 1450$ rpm

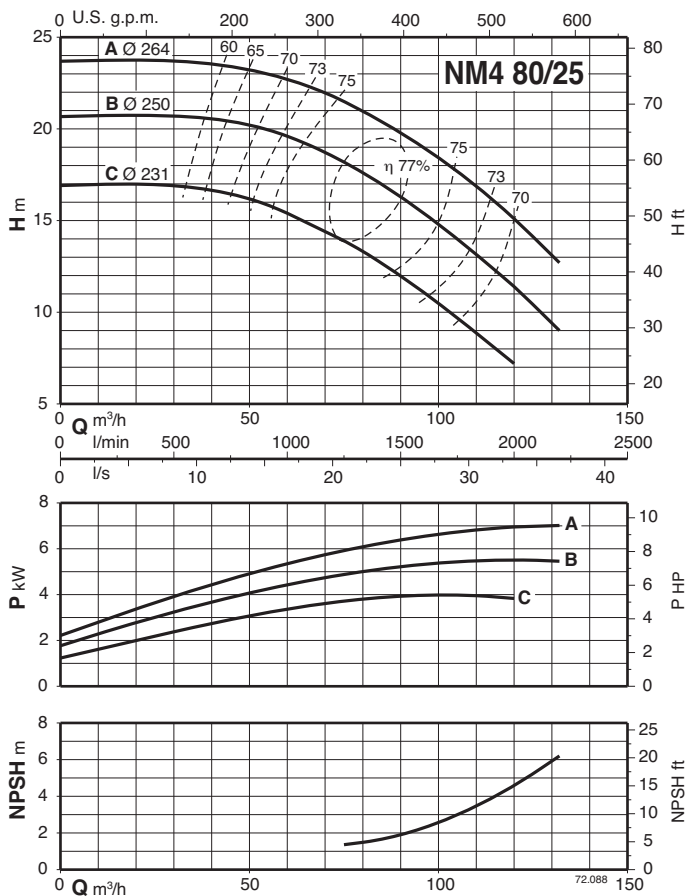
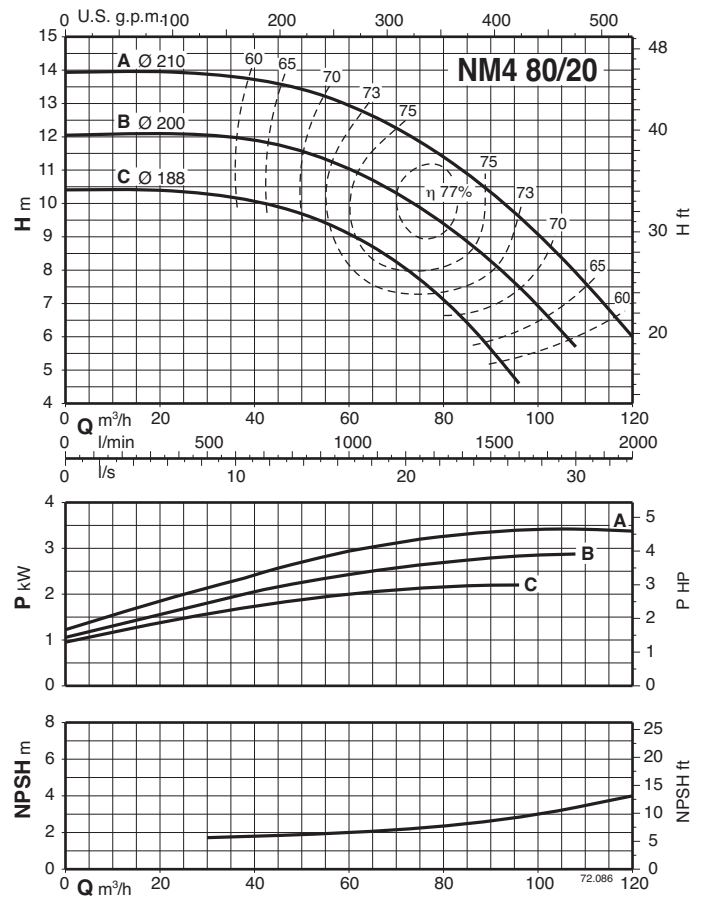
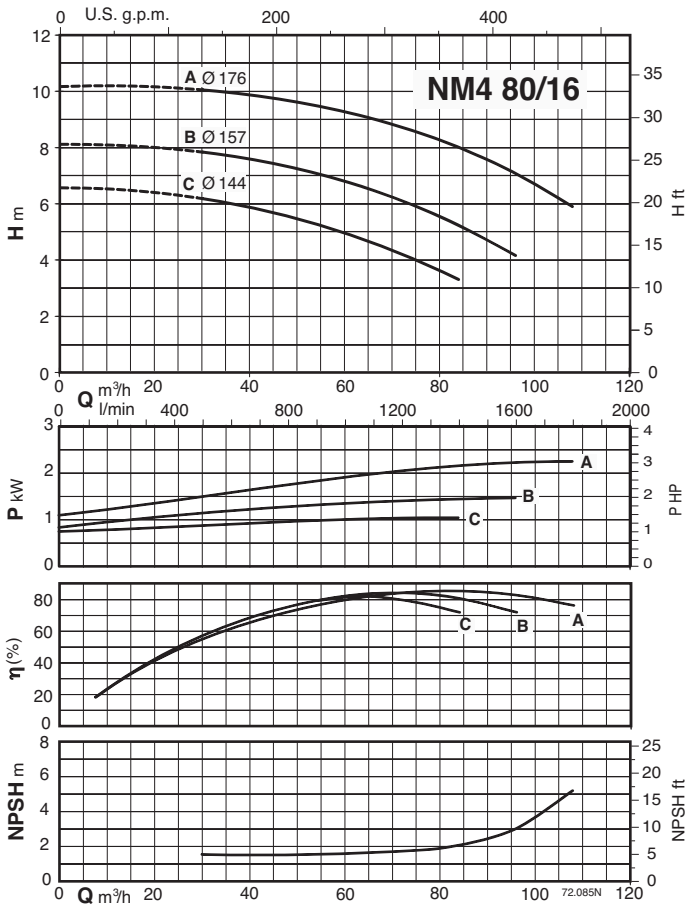

Characteristic curves $n \approx 1450$ rpm

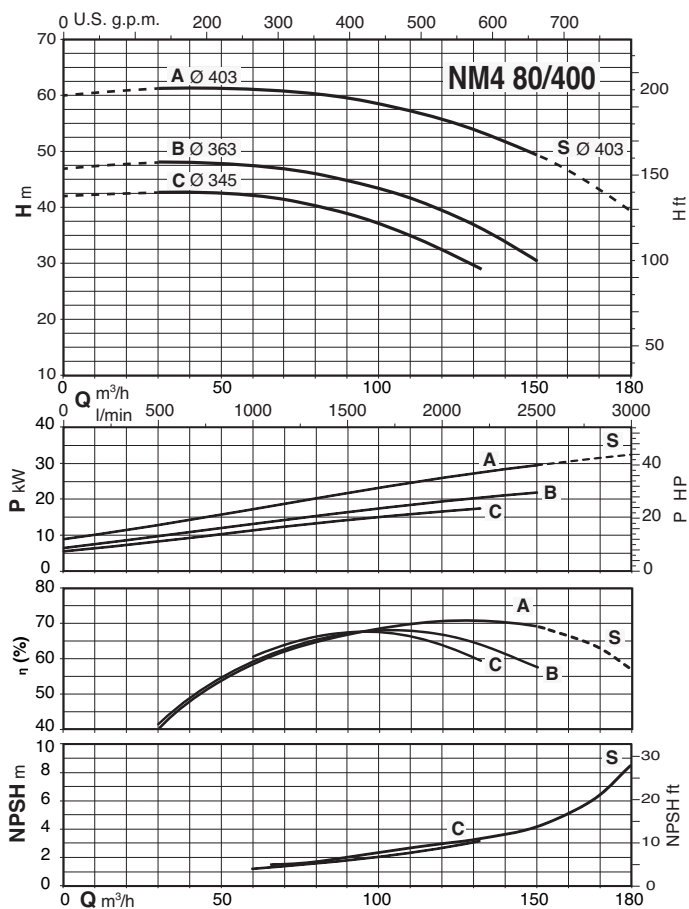
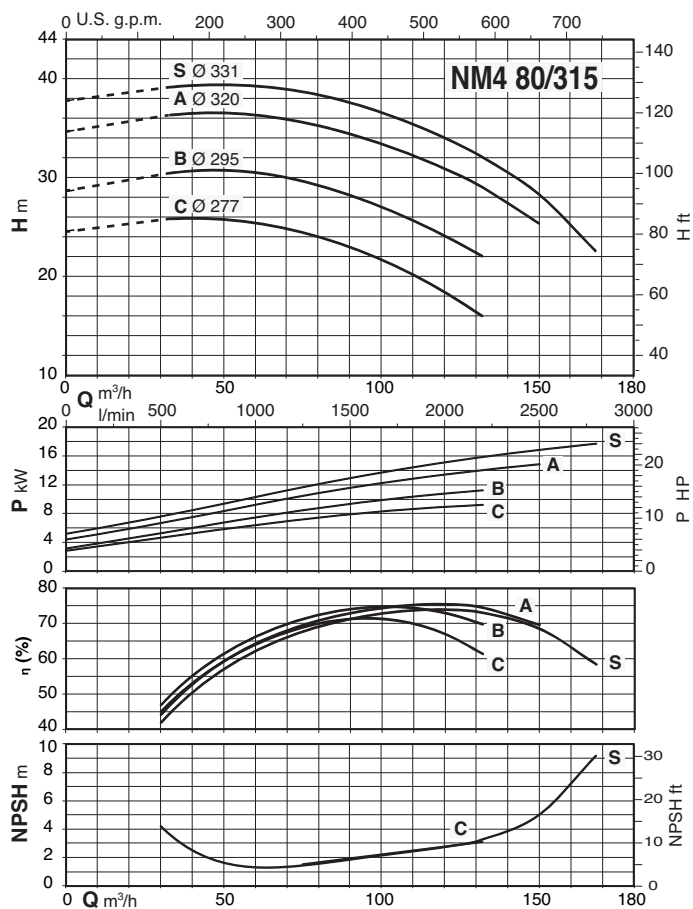

Characteristic curves $n \approx 1450$ rpm

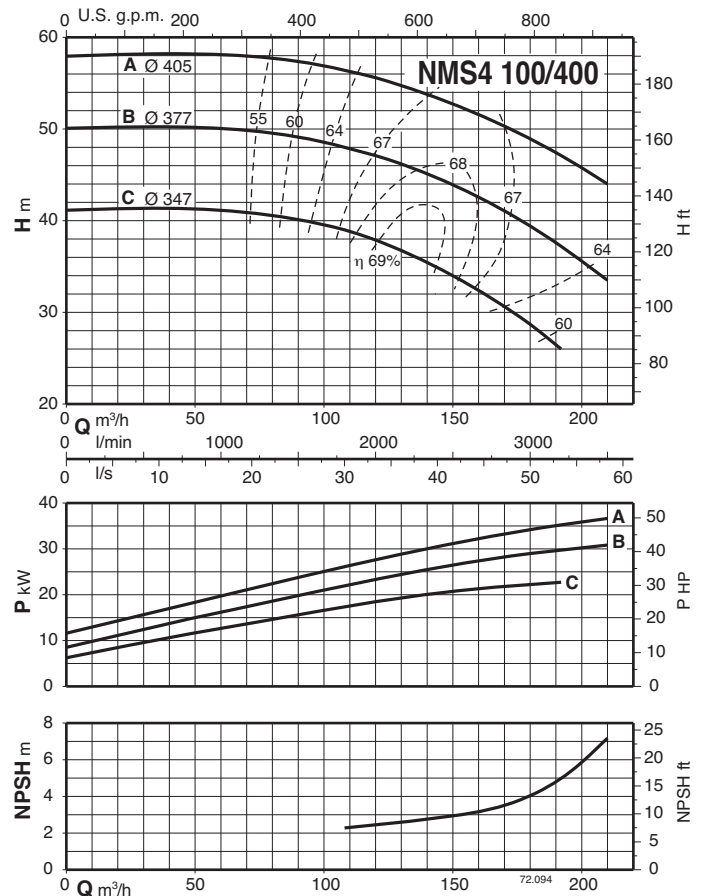
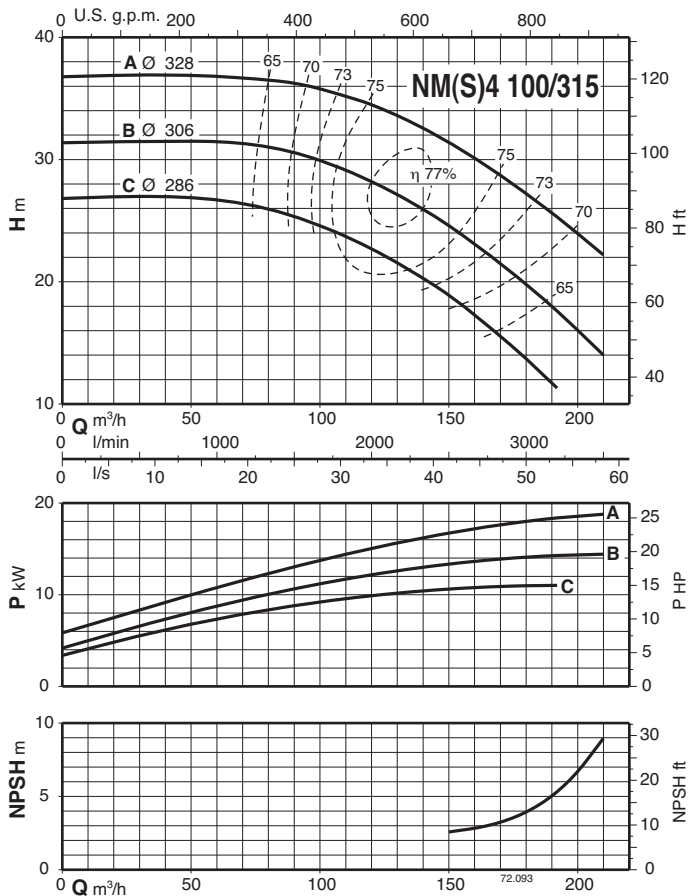
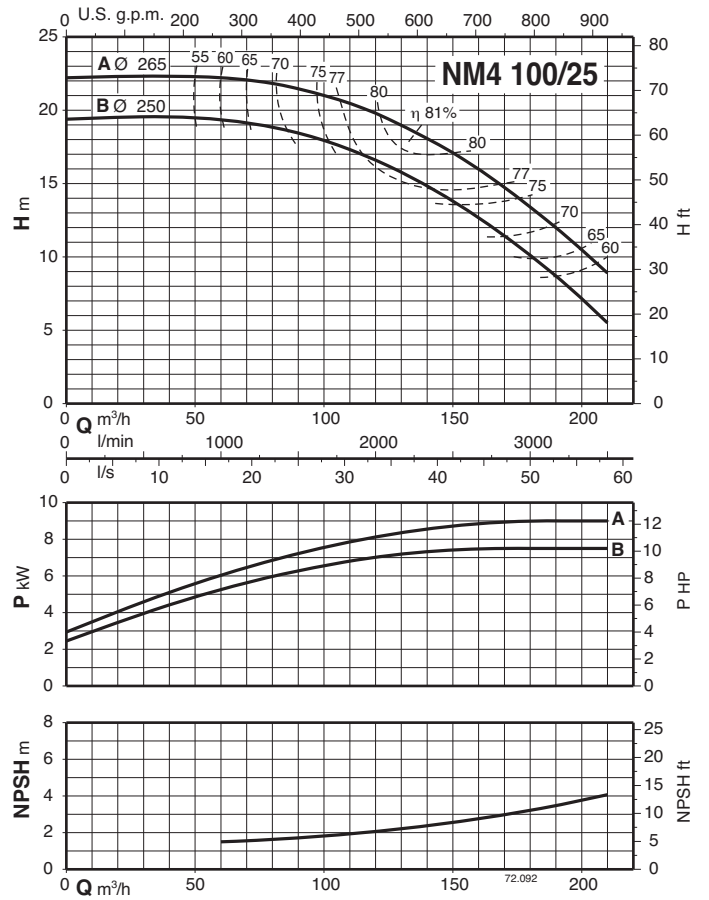
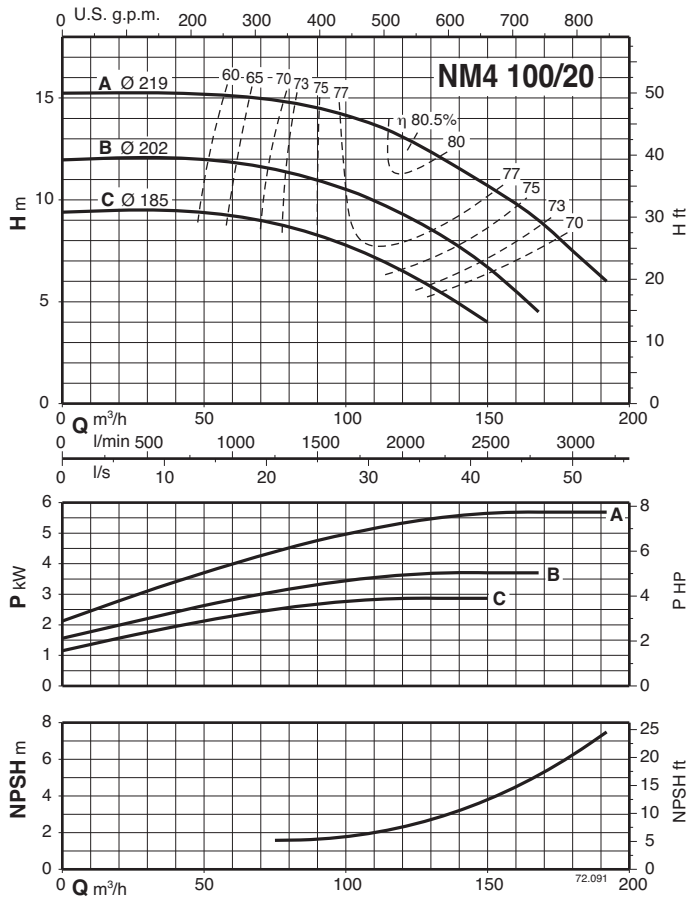

Characteristic curves $n \approx 1450$ rpm

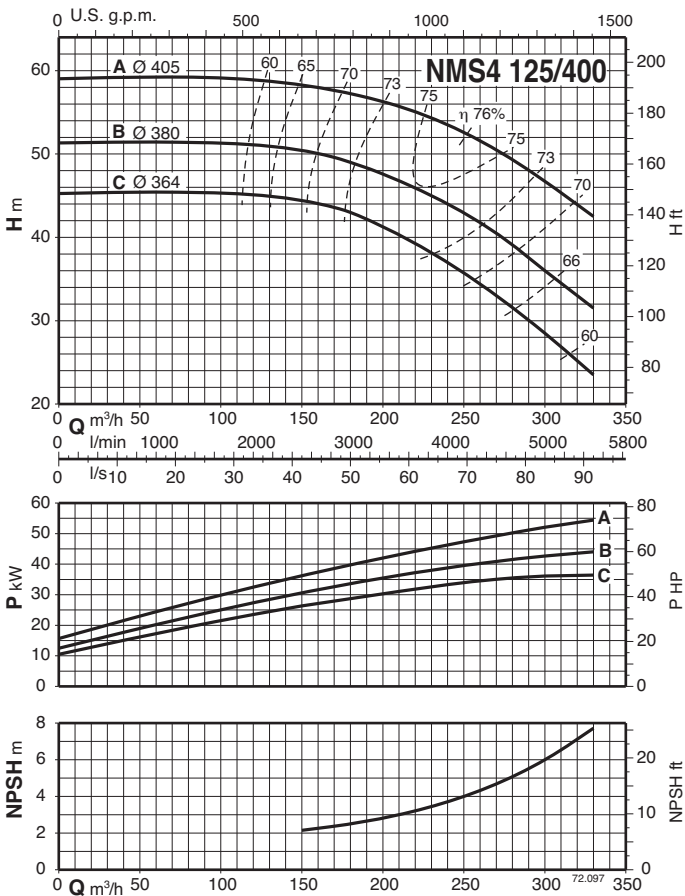
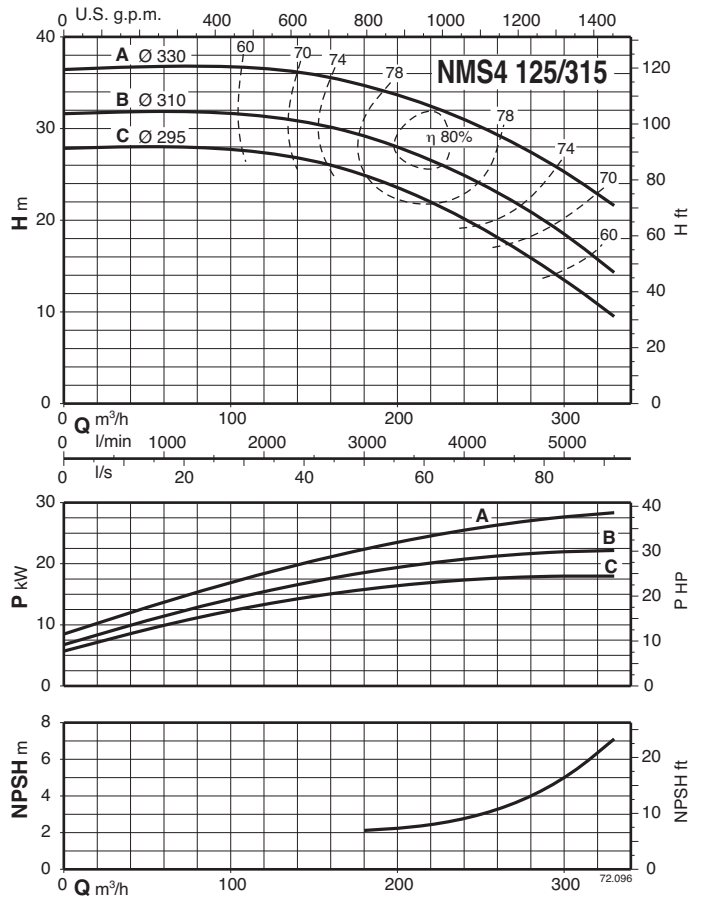
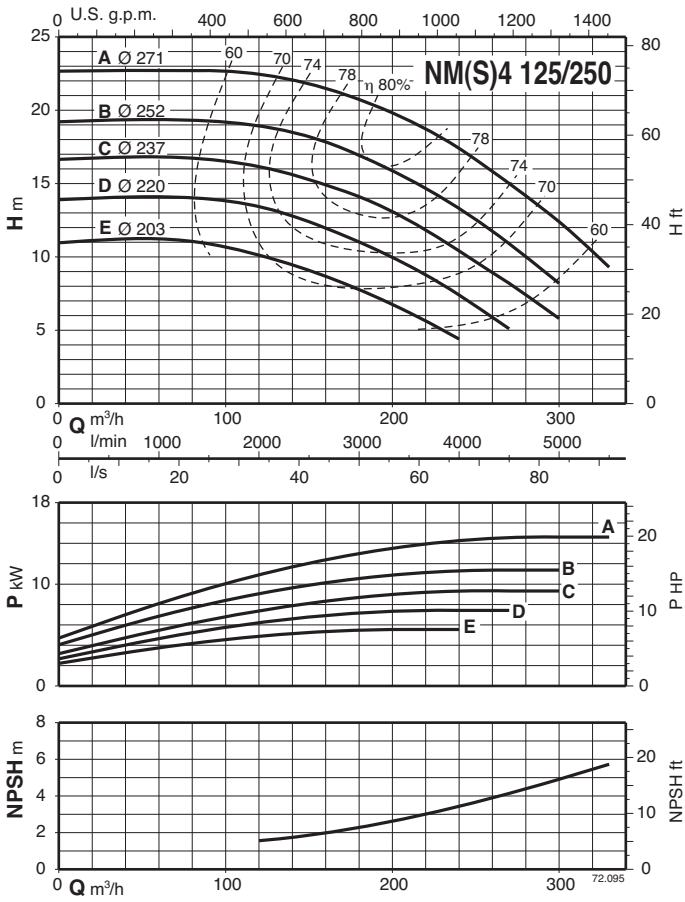

Characteristic curves $n \approx 1450$ rpm

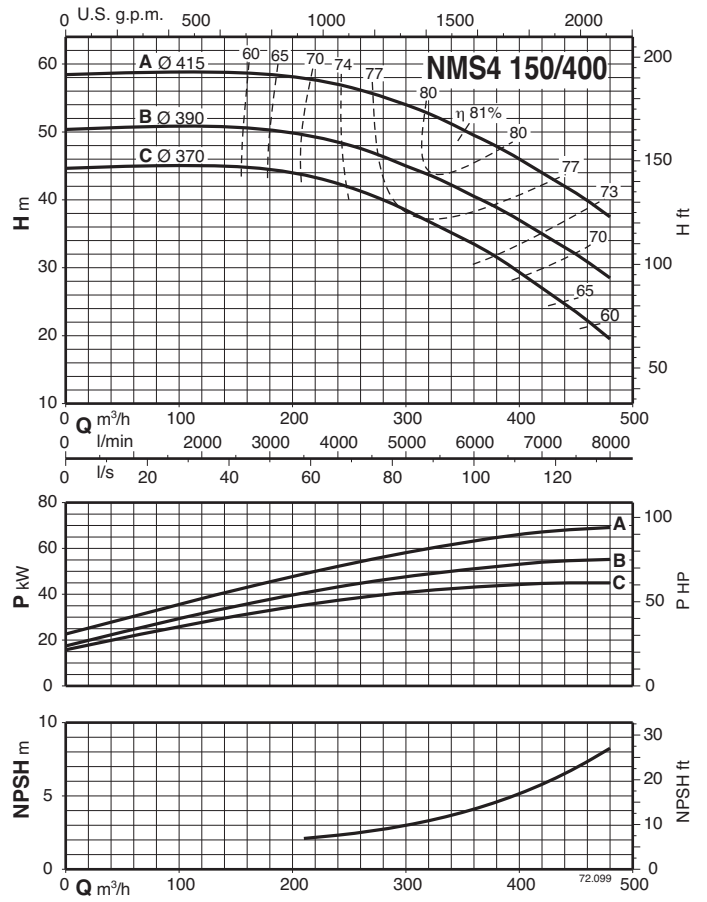
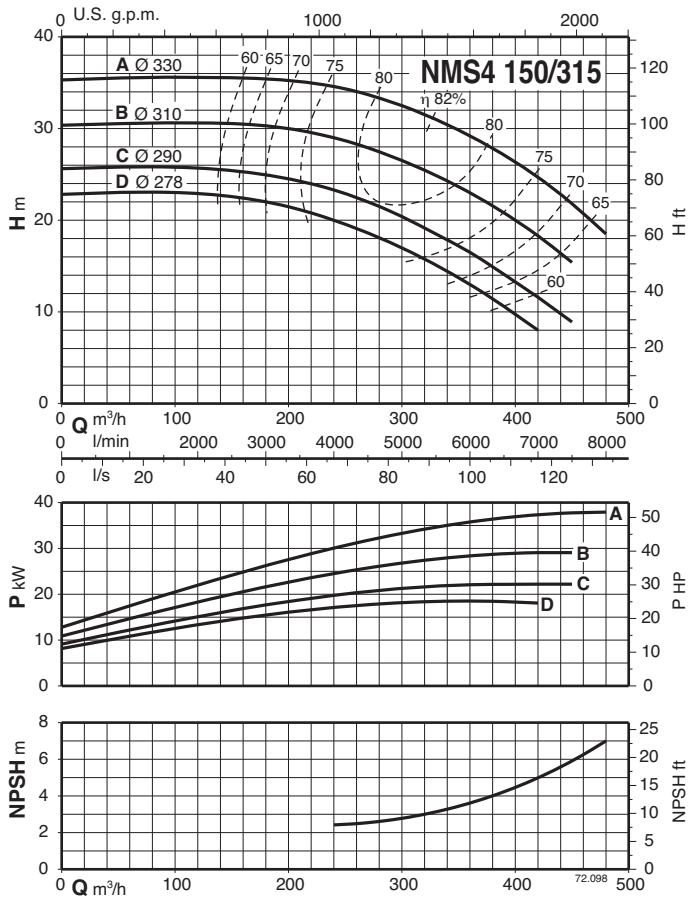

Dimensions and weights

1

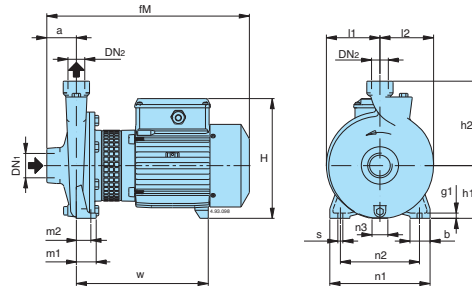

Standard construction

Picture	NM4	DN1	DN2	mm																kg
				a	fM	h1	h2	H	m1	m2	n1	n2	n3	b	s	l1	l2	w	g	
1	NM4 25/12A/A	G 1 1/2	G 1	56	313	90	140	199	37,5	27,5	170	130	9	38	9,5	85	88	250	10	13,5
	NM4 25/160AE-BE			56	380	100	160	228	37,5	27,5	190	150	30	38	9,5	102	102	250	10	17,5
	NM4 25/200B/A-C/A			63	385	125	180	253	45	32,5	245	200	49	45	11,5	125	125	250	11	23-21,5
	NM4 25/200A/C			63	425	125	180	253	45	32,5	245	200	49	45	11,5	125	125	250	11	27

2

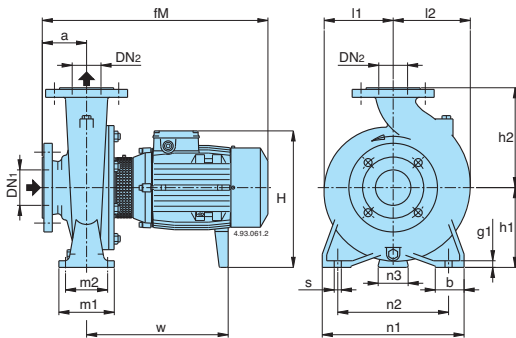

3

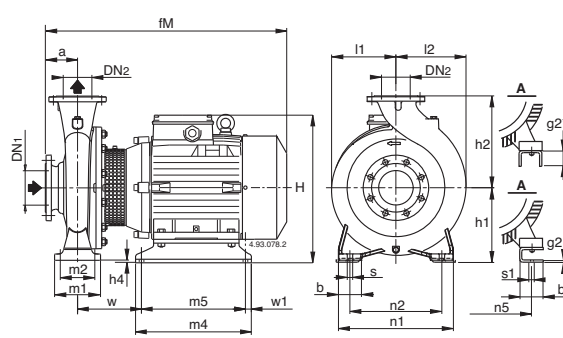

Standard construction

Picture	NM4	mm																				kg							
		DN1	DN2	a	fM	h1	h2	H	h4	m1	m2	n1	n2	n3	n5	w1	b	b1	s	s1	l1		l2	w	m4	m5	g1	g2	
2	NM4 32/16AE-BE	50	32	80	410	132	160	260	-	100	70	240	190	47	-	-	50	-	14	-	120	120	255	-	-	12	-	30,5-30	
	NM4 32/20BE NM4 32/20A/B	50	32	80	410 450	160	180	288	-	100	70	240	190	62	-	-	50	-	14	-	140	140	255	-	-	12	-	35 42	
	NM4 40/16B/A-C/A NM4 40/16A/C	65	40	80	410 450	132	160	268	-	100	70	240	190	47	-	-	50	-	14	-	121	121	255	-	-	10	-	32,4-30,6 39	
	NM4 40/20A/B-B/B	65	40	100	495	160	180	298	-	100	70	265	212	62	-	-	50	-	14	-	142	142	295	-	-	12	-	49,6-49	
	NM4 40/25C/C NM4 40/25A/B-B/C	65	40	100	495 528	180	225	308 340	-	125	95	320	250	60	-	-	65	-	14	-	175	175	300 279	-	-	15	-	67,7 78-76,6	
	NM4 50/16A/C-B/C NM4 50/20A/C	65	50	100	495 528	160	200	288 320	-	100	70	265	212	62 60	-	-	50	-	14	-	140	153	310 279	-	-	14	-	52,5-44,5 57	
	NM4 50/25C/C-D/B NM4 50/25A/B-B/B	65	50	100	528	180	225	340	-	125	95	320	250	60	-	-	65	-	14	-	175	175	279	-	-	15	-	68 85,5-78	
	NM4 65/16A/C-B/C-C/C NM4 65/16S/A	80	65	100	495 528	160	200	288 320	-	125	95	280	212	62 60	-	-	65	-	14	-	140	161	300 279	-	-	12	-	53-49,3-48,7 62,3	
	NM4 65/20A/B-B/C	80	65	100	528	180	225	340	-	125	95	320	250	60	-	-	65	-	14	-	159	178	279	-	-	12	-	69-68,7	
	NM4 65/25B/C NM4 65/25A/B	80	65	100	543 645	200	250	360 385	-	160	120	360	280	60	-	-	80	-	18	-	179	195	294 405	-	-	15	-	97,4 118	
	NM4 65/31C-B-B/B NM4 65/31A/B	80	65	125	670 720	225	280	410	-	160	120	400	315	75	-	-	80	-	18	-	220	220	415 465	-	-	20	-	153-164 176	
	NM4 80/16B/C-C/B NM4 80/16A/C	100	80	125	520 553	180	225	308 340	-	125	95	320	250	62 60	-	-	65	-	14	-	153	181	300 279	-	-	12	-	59,6-55,6 69,8	
	NM4 80/20A/A-B/A-C/B	100	80	125	563	180	250	340	-	125	95	345	280	60	-	-	65	-	14	-	170	194	289	-	-	15	-	91-82-74,5	
	NM4 80/25C/A NM4 80/25B/A-B NM4 80/31C/B	100	80	125	563 670 720	200	280	360 385	-	160	120	400	315	60	-	-	80	-	18	-	191	210	289 415	-	-	20	-	102 124-135 181	
	3	NM4 80/31A-B	100	80	125	787	260	315	466	10	160	120	400	315	-	254	20	80	74	18	14	222	234	147	435	395	-	6	269-248
		NM4 100/20B/A-C/A NM4 100/20A/C	125	100	125	563 665	200	280	360 385	-	160	120	360	280	60	-	-	80	-	18	-	180	212	289 400	-	-	20	-	99-90 109
	2	NM4 100/25B/B NM4 100/25A/B	125	100	140	685 735	225	280	410	-	160	120	400	315	75	-	-	80	-	18	-	205	233	415 465	-	-	20	-	143 152
		NM4 100/31B-C	125	100	140	802	260	315	466	10	160	120	400	315	-	254	20	80	74	18	14	230	250	147	435	395	-	6	280-261
	3	NM4 125/25E/B-D/B NM4 125/25C/B	150	125	140	685 735	250	355	435	-	160	120	400	315	90	-	-	80	-	18	-	235	268	415 465	-	-	20	-	149-161 173
		NM4 125/25A-B	150	125	140	802	260	355	466	10	160	120	400	315	-	254	20	80	74	18	14	235	268	147	435	395	-	6	261-243

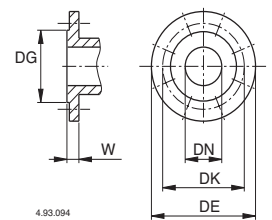

mm						
DN	DG	DK	DE	N°	Ø	
32	76	100	140	4	19	18
40	84	110	150	4	19	18
50	99	125	165	4	19	20
65	118	145	185	4	19	20
80	132	160	200	8	19	22
100	156	180	220	8	19	24
125	184	210	250	8	19	24
150	211	240	285	8	23	26
200	266	295	340	8	23	30

Dimensions and weights

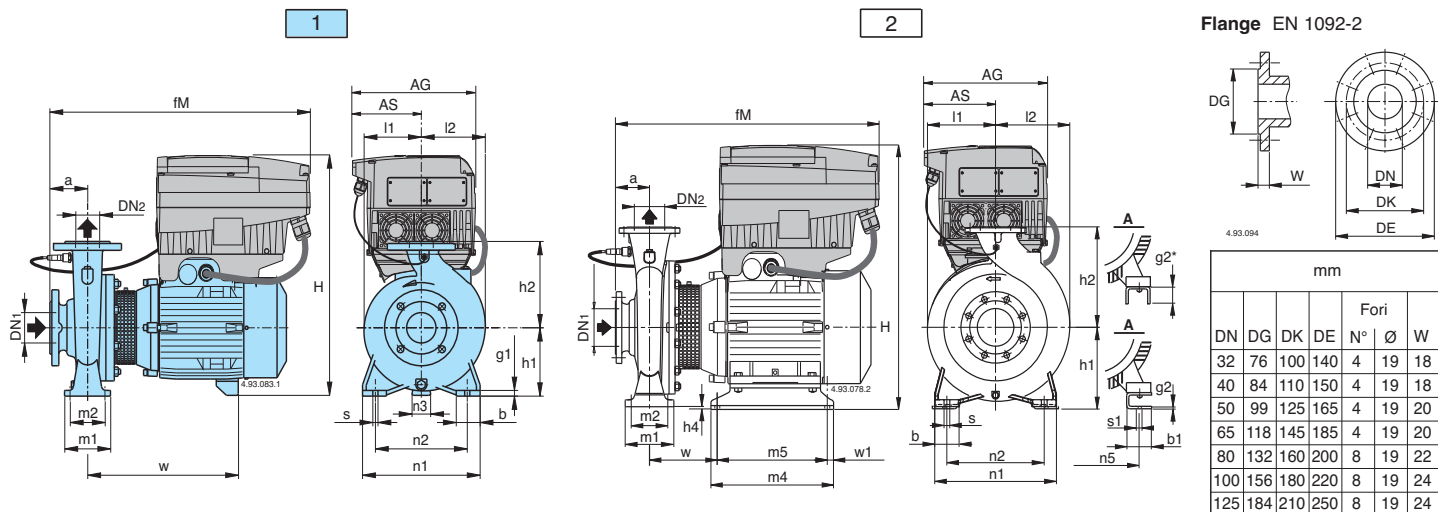

Picture	NM4 EI	mm																										kg		
		DN1	DN2	a	fM	AG	AS	h1	h2	H	h4	m1	m2	n1	n2	n3	n5	w1	b	b1	s	s1	l1	l2	w	m4	m5		g1	g2
1	NM4 EI 32/16AE-BE	50	32	80	440	190	105	132	160	418	-	100	70	240	190	47	-	-	50	-	14	-	120	120	255	-	-	12	-	37-36,4
	NM4 EI 32/20BE	50	32	80	440	190	105	160	180	466	-	100	70	240	190	62	-	-	50	-	14	-	140	140	255	-	-	12	-	40,9
	NM4 EI 32/20A/B	50	32	80	450	190	105	160	180	466	-	100	70	240	190	62	-	-	50	-	14	-	140	140	255	-	-	12	-	48,4
	NM4 EI 40/16B/A-C/A	65	40	80	440	190	105	132	160	418	-	100	70	240	190	47	-	-	50	-	14	-	121	121	255	-	-	10	-	38,4-36,4
	NM4 EI 40/16A/C	65	40	80	450	190	105	132	160	418	-	100	70	240	190	47	-	-	50	-	14	-	121	121	255	-	-	10	-	45,4
	NM4 EI 40/20A/B-B/B	65	40	100	495	190	105	160	180	547	-	100	70	265	212	62	-	-	50	-	14	-	142	142	295	-	-	12	-	57,4-56,9
	NM4 EI 40/25C/C	65	40	100	495	190	105	180	225	474	-	125	95	320	250	60	-	-	65	-	14	-	175	175	300	-	-	15	-	74
	NM4 EI 40/25A/B-B/C	65	40	100	528	210	118	180	225	502	-	125	95	320	250	60	-	-	65	-	14	-	175	175	300	-	-	15	-	85,5-85
	NM4 EI 50/16A/C-B/C	65	50	100	495	190	105	160	180	454	-	100	70	265	212	62	-	-	50	-	14	-	126	140	295	-	-	12	-	46,4-46
	NM4 EI 50/20B/C-C/C	65	50	100	505	190	105	160	200	454	-	100	70	265	212	62	-	-	50	-	14	-	140	153	310	-	-	14	-	59-51
	NM4 EI 50/20A/C	65	50	100	528	210	118	160	200	482	-	100	70	265	212	60	-	-	50	-	14	-	140	153	279	-	-	14	-	63,4
	NM4 EI 50/25C/C-D/B	65	50	100	528	210	118	180	225	502	-	125	95	320	250	60	-	-	65	-	14	-	175	175	279	-	-	15	-	74,4-74,4
	NM4 EI 50/25A/B-B/B	65	50	100	528	210	118	180	225	502	-	125	95	320	250	60	-	-	65	-	14	-	175	175	279	-	-	15	-	93,0-85,5
	NM4 EI 65/16B/C-C/C	80	65	100	495	190	105	160	200	454	-	125	95	280	212	62	-	-	65	-	14	-	140	161	300	-	-	15	-	54,4-54,4
NM4 EI 65/16A/C	80	65	100	495	190	105	160	200	454	-	125	95	280	212	62	-	-	65	-	14	-	140	161	300	-	-	15	-	60,9	
NM4 EI 65/16S/A	80	65	100	528	210	118	160	200	528	-	125	95	280	212	60	-	-	65	-	14	-	140	161	279	-	-	15	-	61,4	
NM4 EI 65/20A/B-B/C	80	65	100	528	210	118	180	225	502	-	125	95	320	250	60	-	-	65	-	14	-	159	179	279	-	-	12	-	81-67,4	
NM4 EI 65/25B/C	80	65	100	543	210	118	200	250	522	-	160	120	360	280	60	-	-	80	-	18	-	179	195	294	-	-	15	-	104,5	
NM4 EI 65/25A/B	80	65	100	645	281	153	200	250	593	-	160	120	360	280	60	-	-	80	-	18	-	179	195	405	-	-	15	-	130,8	
NM4 EI 65/31C/B-B/B	80	65	125	670	281	153	225	280	618	-	160	120	400	315	75	-	-	80	-	18	-	220	220	415	-	-	20	-	179-168	
NM4 EI 65/31A/B	80	65	125	720	281	153	225	280	618	-	160	120	400	315	75	-	-	80	-	18	-	220	220	465	-	-	20	-	190,8	
NM4 EI 80/16B/C-C/B	100	80	125	520	190	105	180	225	454	-	125	95	320	250	60	-	-	65	-	14	-	153	181	300	-	-	12	-	67,4-59,4	
NM4 EI 80/16A/C	100	80	125	553	210	118	180	225	545	-	125	95	320	250	62	-	-	65	-	14	-	153	181	279	-	-	12	-	71,9	
NM4 EI 80/20A/A-B/A-C/B	100	80	125	563	210	118	180	250	502	-	125	95	345	280	60	-	-	65	-	14	-	170	194	289	-	-	15	-	99-90-81	
NM4 EI 80/25C/A	100	80	125	563	210	118	200	280	522	-	160	120	400	315	60	-	-	80	-	18	-	191	210	289	-	-	20	-	109,5	
NM4 EI 80/25B/A-B	100	80	125	670	281	153	200	280	593	-	160	120	400	315	60	-	-	80	-	18	-	191	210	415	-	-	20	-	150-139	
NM4 EI 80/31C/B	100	80	125	745	281	153	250	315	613	-	160	120	400	315	90	-	-	80	-	18	-	222	234	465	-	-	17	-	195,8	
NM4 EI 80/31B	100	80	125	790	281	153	260	315	671	-	160	120	400	315	-	254	20	80	74	18	14	222	234	147	435	395	-	6	283	
NM4 EI 80/31A	100	80	125	350	190	105	260	315	751	-	160	120	400	315	-	254	20	80	74	18	14	222	234	147	435	395	-	6	304	
NM4 EI 100/20B/A-C/A	125	100	125	563	210	118	200	280	522	-	160	120	360	280	60	-	-	80	-	18	-	180	212	289	-	-	20	-	107-97,5	
NM4 EI 100/20A/C	125	100	125	665	281	153	200	280	593	-	160	120	360	280	60	-	-	80	-	18	-	180	212	400	-	-	20	-	123,8	
NM4 EI 100/25B/B	125	100	140	685	281	153	225	280	618	-	160	120	400	315	75	-	-	80	-	18	-	205	233	415	-	-	20	-	166,8	
NM4 EI 100/25A/B	125	100	140	735	281	153	225	280	618	-	160	120	400	315	75	-	-	80	-	18	-	205	233	465	-	-	20	-	157,8	
NM4 EI 100/31C	125	100	140	805	281	153	260	315	671	-	160	120	400	315	-	254	20	80	74	18	14	230	250	147	435	395	-	6	296	
NM4 EI 100/31B	125	100	140	350	190	105	260	315	751	-	160	120	400	315	-	254	20	80	74	18	14	230	250	147	435	395	-	6	315	
NM4 EI 125/25E/B-D/B	150	125	140	685	281	153	250	355	643	-	160	120	400	315	90	-	-	80	-	18	-	235	268	415	-	-	20	-	164-176	
NM4 EI 125/25C/B	150	125	140	735	281	153	250	355	643	-	160	120	400	315	90	-	-	80	-	18	-	235	268	465	-	-	20	-	187,8	
NM4 EI 125/25B	150	125	140	805	281	153	260	355	671	-	160	120	400	315	-	254	20	80	74	18	14	235	268	147	435	395	-	6	378	
NM4 EI 125/25A	150	125	140	350	190	105	260	355	751	-	160	120	400	315	-	254	20	80	74	18	14	235	268	147	435	395	-	6	296	

Dimensions and weights

Flanges EN 1092-2

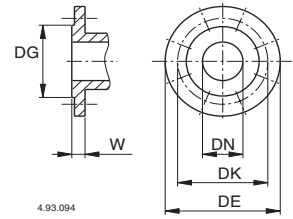

4.93.094

mm						
DN	DG	DK	DE	Holes		W
				N°	Ø	
32	76	100	140	4	19	18
40	84	110	150	4	19	18
50	99	125	165	4	19	20
65	118	145	185	4	19	20
80	132	160	200	8	19	22
100	156	180	220	8	19	24
125	184	210	250	8	19	24
150	211	240	285	8	23	26
200	266	295	340	8	23	30

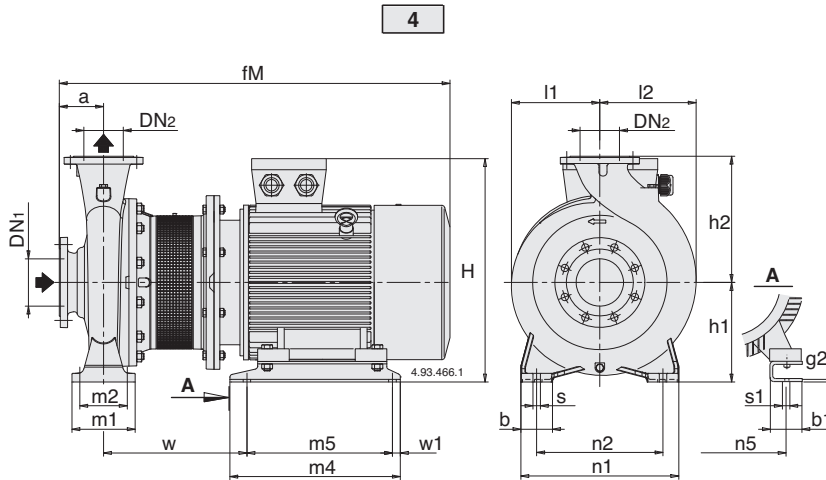

Standard construction

Picture	NMS4	mm																				kg			
		DN ₁	DN ₂	a	fM	h ₁	h ₂	H	m ₁	m ₂	n ₁	n ₂	n ₅	w ₁	b	b ₁	s	s ₁	l ₁	l ₂	w		m ₄	m ₅	g ₂
4	NMS4 80/315S	100	80	125	968	250	315	536	160	120	400	315	279	25	80	70	18	15	222	234	312	432	382	6	
	NMS4 80/400C/B	125	80	125	973	280	355	566	160	120	435	355	279	25	80	70	18	15	268	269	318	520	435	6	339
	NMS4 80/400B/B	125	80	125	1003	280	355	566	160	120	435	355	279	25	80	70	18	15	268	269	318	520	435	6	355
	NMS4 80/400A/B	125	80	125	1051	280	355	595	160	120	435	355	318	25	80	83	18	19	268	269	334	540	455	6	413
	NMS4 80/400S	125	80	125	1118	280	355	618	160	120	435	355	356	55	80	103	18	19	268	269	380	540	460	8	490
	NMS4 100/315A/A	125	100	140	983	250	315	536	160	120	400	315	279	25	80	70	18	15	230	250	312	432	382	6	308
	NMS4 100/400C/A	125	100	140	1018	280	355	566	200	150	500	400	279	25	100	70	22	15	268	280	318	520	435	6	366
	NMS4 100/400B/A	125	100	140	1066	280	355	595	200	150	500	400	318	25	100	83	22	19	268	280	334	540	455	6	419
	NMS4 100/400A/A	125	100	140	1138	280	355	618	200	150	500	400	356	55	100	103	22	19	268	280	385	540	460	8	506
	NMS4 125/315C/A	150	125	140	988	280	355	566	200	150	500	400	279	25	100	70	22	15	247	278	318	520	435	6	331
	NMS4 125/315B/A	150	125	140	1018	280	355	566	200	150	500	400	279	25	100	70	22	15	247	278	318	520	435	6	350
	NMS4 125/315A/A	150	125	140	1066	280	355	595	200	150	500	400	318	25	100	83	22	19	247	278	334	540	455	6	409
	NMS4 125/400C/A	150	125	140	1138	315	400	653	200	150	500	400	356	25	100	103	22	19	280	305	410	540	461	8	524
	NMS4 125/400B/A	150	125	140	1198	315	400	653	200	150	500	400	356	25	100	103	22	19	280	305	410	540	461	8	574
	NMS4 125/400A/A	150	125	140	1237	315	400	725	200	150	500	400	406	25	100	100	22	24	280	305	454	540	461	8	665
	NMS4 150/315D/A	200	150	160	1008	280	400	566	200	150	550	450	279	25	100	70	22	15	260	298	318	520	435	6	349
	NMS4 150/315C/A	200	150	160	1038	280	400	566	200	150	550	450	279	25	100	70	22	15	260	298	318	520	435	6	374
	NMS4 150/315B/A	200	150	160	1086	280	400	595	200	150	550	450	318	25	100	83	22	19	260	298	334	540	455	6	421
	NMS4 150/315A/A	200	150	160	1158	280	400	618	200	150	550	450	356	55	100	103	22	19	260	298	385	540	460	8	501
	NMS4 150/400C/A	200	150	160	1218	315	450	653	200	150	550	450	356	25	100	103	22	19	295	328	410	540	461	8	594
NMS4 150/400B/A	200	150	160	1257	315	450	725	200	150	550	450	406	25	100	100	22	24	295	328	454	540	461	8	681	
NMS4 150/400A/A	200	150	160	1330	315	450	748	200	150	550	450	457	45	100	100	22	24	295	328	482	625	535	6	845	

Dimensions and weights

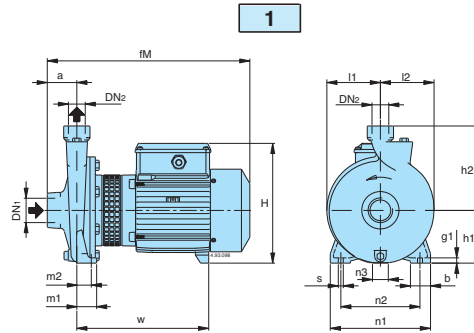

Bronze construction B-NM4

Picture	B-NM4	DN1 ISO 228	DN2	mm																	kg
				a	fM	h1	h2	H	m1	m2	n1	n2	n3	b	s	l1	l2	w	g		
1	B-NM4 25/160AE-BE	G 1 1/2	G 1	56	380	100	160	228	37,5	27,5	190	150	30	38	9,5	102	102	250	10	19-19	
	B-NM4 25/200B/A-C/A			63	400	125	180	253	45	32,5	245	200	49	45	11,5	125	125	250	11	25-23	
	B-NM4 25/200A/C			63	445	125	180	253	45	32,5	245	200	49	45	11,5	125	125	303	11	29	

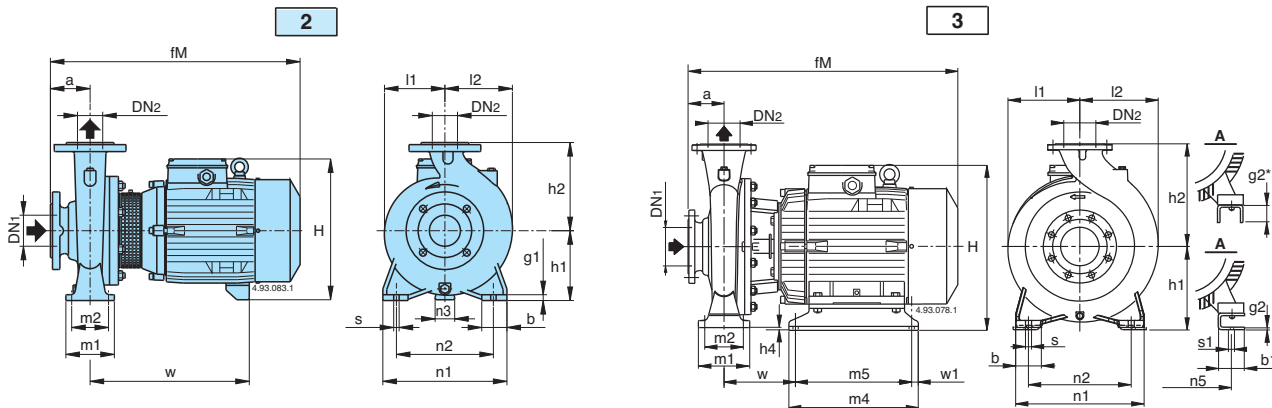

Bronze construction B-NM4

Picture	B-NM4	mm																				kg							
		DN1	DN2	a	fM	h1	h2	H	h4	m1	m2	n1	n2	n3	n5	w1	b	b1	s	s1	l1		l2	w	m4	m5	g1	g2	
2	B-NM4 32/16A-B	50	32	80	410	132	160	260	-	100	70	240	190	47	-	-	50	-	14	-	120	120	255	-	-	12	-	38-38	
	B-NM4 32/20B	50	32	80	410	160	180	288	-	100	70	240	190	62	-	-	50	-	14	-	140	140	255	-	-	12	-	41	
	B-NM4 32/20A/A	50	32	80	450	160	180	288	-	100	70	240	190	62	-	-	50	-	14	-	140	140	255	-	-	12	-	45	
	B-NM4 40/16B-C	65	40	80	410	132	160	260	-	100	70	240	190	47	-	-	50	-	14	-	121	121	255	-	-	10	-	36,6-34,7	
2	B-NM4 40/16A/B	65	40	80	450	132	160	260	-	100	70	240	190	47	-	-	50	-	14	-	121	121	255	-	-	10	-	43	
	B-NM4 40/20A/B-B/B	65	40	100	495	160	180	298	-	100	70	265	212	62	-	-	50	-	14	-	142	142	295	-	-	12	-	55-55	
3	B-NM4 40/25/C/C	65	40	100	535	190	225	318	10	125	95	320	250	-	140	15	65	54	14	10	175	175	156	205	175	-	6	73	
	B-NM4 40/25A/B-B/C	65	40	100	560	190	225	350	10	125	95	320	250	-	190	15	65	60	14	12	175	175	125	280	250	-	6	89-73	
2	B-NM4 50/16A/B-B/B	65	50	100	495	160	180	298	-	100	70	265	212	62	-	-	50	-	14	-	126	140	295	-	-	12	-	55-55	
3	B-NM4 50/25/C/C-D/B	65	50	100	560	190	225	350	10	125	95	320	250	-	190	15	65	60	14	12	175	175	125	280	250	-	6	79,5	
	B-NM4 50/25A/B-B/B	65	50	100	560	190	225	350	10	125	95	320	250	-	190	15	65	60	14	12	175	175	125	280	250	-	6	105-92	
2	B-NM4 65/16A/C-B/C-C/C	80	65	100	495	160	200	306	-	125	95	280	212	62	60	-	65	-	14	-	140	161	300	279	-	-	12	-	60-57-66
	B-NM4 65/16A/B	80	65	100	528	160	200	320	-	125	95	280	212	62	60	-	65	-	14	-	140	161	300	279	-	-	12	-	69,8
	B-NM4 65/20A/A-B/A	80	65	100	528	180	225	340	-	125	95	320	250	60	-	-	65	-	14	-	159	179	279	-	-	12	-	-	
	B-NM4 65/25B/B	80	65	100	540	200	250	360	-	160	120	360	280	60	-	-	80	-	18	-	179	195	345	405	-	-	15	-	109
	B-NM4 65/25A/C	80	65	100	645	200	250	385	-	160	120	360	280	60	-	-	80	-	18	-	179	195	405	465	-	-	20	-	128
	B-NM4 65/31C/B-B/B	80	65	125	670	225	280	410	-	160	120	400	315	75	-	-	80	-	18	-	220	220	415	465	-	-	20	-	170-..
	B-NM4 65/31A/B	80	65	125	720	225	280	410	-	160	120	400	315	75	-	-	80	-	18	-	220	220	465	465	-	-	20	-	-
	B-NM4 80/20A-B-C	100	80	125	560	180	250	340	-	125	95	345	280	60	-	-	65	-	14	-	170	194	340	-	-	15	-	-	97,2-89,7-..
	B-NM4 80/25C/A	100	80	125	565	200	280	360	-	160	120	400	315	60	-	-	80	-	18	-	191	210	335	-	-	20	-	-	115
	B-NM4 80/31C	100	80	125	720	250	315	435	-	160	120	400	315	90	-	-	80	-	18	-	222	234	465	-	-	17	-	-	-
2	B-NM4 100/20B/A-C/A	125	100	125	565	200	280	360	-	160	120	360	280	60	-	-	80	-	18	-	180	212	330	-	-	20	-	-	109-103
	B-NM4 100/20A/C	125	100	125	665	200	280	385	-	160	120	360	280	60	-	-	80	-	18	-	180	212	400	-	-	20	-	-	129

Flanges EN 1092-2

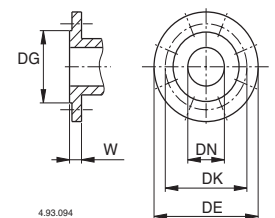

mm						
DN	DG	DK	DE	Holes		W
				N°	Ø	
32	76	100	140	4	19	18
40	84	110	150	4	19	18
50	99	125	165	4	19	20
65	118	145	185	4	19	20
80	132	160	200	8	19	22
100	156	180	220	8	19	24
125	184	210	250	8	19	24
150	211	240	285	8	23	26
200	266	295	340	8	23	30

Dimensions and weights

Flanges EN 1092-2

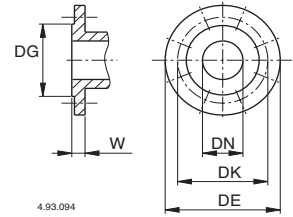
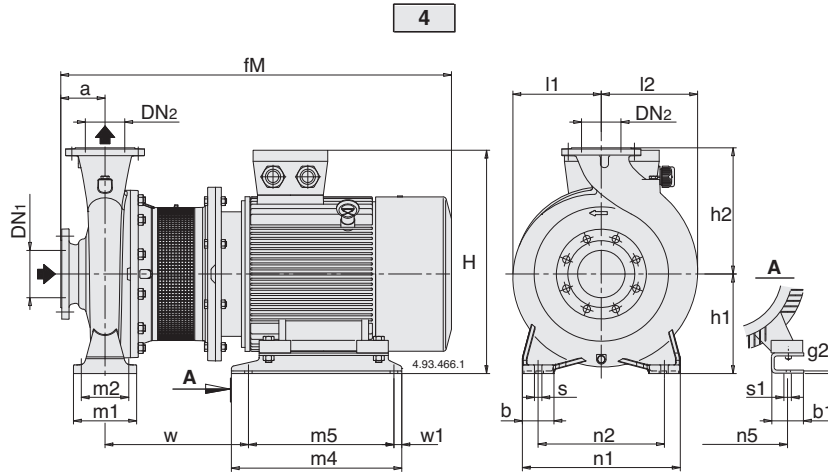

mm						
DN	DG	DK	DE	Holes		W
				N°	Ø	
32	76	100	140	4	19	18
40	84	110	150	4	19	18
50	99	125	165	4	19	20
65	118	145	185	4	19	20
80	132	160	200	8	19	22
100	156	180	220	8	19	24
125	184	210	250	8	19	24
150	211	240	285	8	23	26
200	266	295	340	8	23	30

Bronze construction B-NM4

Picture	B-NMS4	mm																				kg			
		DN1	DN2	a	fM	h1	h2	H	m1	m2	n1	n2	n5	w1	b	b1	s	s1	l1	l2	w		m4	m5	g2
4	BNMS4 80/250A/A-B/A	100	80	125	807	200	280	387	160	120	400	315	216	20	80	69	18	12	191	210	322	298	258	6	181-171
	BNMS4 80/315B/B	100	80	125	948	250	315	457	160	120	400	315	254	20	80	60	18	15	222	234	271	435	395	6	
	BNMS4 80/315A/B	100	80	125	948	250	315	457	160	120	400	315	254	20	80	60	18	15	222	234	271	435	395	6	
	BNMS4 80/315S	100	80	125	968	250	315	536	160	120	400	315	279	25	80	70	18	15	222	234	312	432	382	6	
	BNMS4 80/400C/B	125	80	125	973	280	355	566	160	120	435	355	279	25	80	70	18	15	268	269	318	520	435	6	
	BNMS4 80/400B/B	125	80	125	1003	280	355	566	160	120	435	355	279	25	80	70	18	15	268	269	318	520	435	6	
	BNMS4 80/400A/B	125	80	125	1051	280	355	595	160	120	435	355	318	25	80	83	18	19	268	269	334	540	455	6	
	BNMS4 80/400S	125	80	125	1118	280	355	618	160	120	435	355	356	55	80	103	18	19	268	269	380	540	460	8	
	BNMS4 100/250B/A	125	100	140	822	225	280	412	160	120	400	315	216	20	80	69	18	12	205	233	322	298	258	6	192
	BNMS4 100/250A/A	125	100	140	872	225	280	412	160	120	400	315	216	20	80	69	18	12	205	233	322	298	258	6	206
	BNMS4 100/315C/A	125	100	140	966	250	315	457	160	120	400	315	254	20	80	60	18	15	230	250	274	435	395	6	284
	BNMS4 100/315B/A	125	100	140	966	250	315	457	160	120	400	315	254	20	80	60	18	15	230	250	274	435	395	6	300
	BNMS4 100/315A/A	125	100	140	983	250	315	536	160	120	400	315	279	25	80	70	18	15	230	250	312	432	382	6	
	BNMS4 100/400C/A	125	100	140	1018	280	355	566	200	150	500	400	279	25	100	70	22	15	268	280	318	520	435	6	
	BNMS4 100/400B/A	125	100	140	1066	280	355	595	200	150	500	400	318	25	100	83	22	19	268	280	334	540	455	6	
	BNMS4 100/400A/A	125	100	140	1138	280	355	618	200	150	500	400	356	55	100	103	22	19	268	280	385	540	460	8	
	BNMS4 125/250D/A-E/A	150	125	140	822	250	355	437	160	120	400	315	216	20	80	69	18	12	235	268	322	298	258	6	
	BNMS4 125/250C/A	150	125	140	872	250	355	437	160	120	400	315	216	20	80	69	18	12	235	268	322	298	258	6	
	BNMS4 125/250B/A	150	125	140	951	250	355	457	160	120	400	315	254	20	80	60	18	15	235	268	259	435	395	6	265
	BNMS4 125/250A/A	150	125	140	951	250	355	457	160	120	400	315	254	20	80	60	18	15	235	268	259	435	395	6	273
	BNMS4 125/315C/A	150	125	140	988	280	355	566	200	150	500	400	279	25	100	70	22	15	247	278	318	520	435	6	383
	BNMS4 125/315B/A	150	125	140	1018	280	355	566	200	150	500	400	279	25	100	70	22	15	247	278	318	520	435	6	395
	BNMS4 125/315A/A	150	125	140	1066	280	355	595	200	150	500	400	318	25	100	83	22	19	247	278	334	540	455	6	
	BNMS4 125/400C/A	150	125	140	1138	315	400	653	200	150	500	400	356	25	100	103	22	19	280	305	410	540	461	8	
	BNMS4 125/400B/A	150	125	140	1198	315	400	653	200	150	500	400	356	25	100	103	22	19	280	305	410	540	461	8	
	BNMS4 125/400A/A	150	125	140	1237	315	400	725	200	150	500	400	406	25	100	100	22	24	280	305	454	540	461	8	
	BNMS4 150/315D/A	200	150	160	1008	280	400	566	200	150	550	450	279	25	100	70	22	15	260	298	318	520	435	6	380
	BNMS4 150/315C/A	200	150	160	1038	280	400	566	200	150	550	450	279	25	100	70	22	15	260	298	318	520	435	6	395
	BNMS4 150/315B/A	200	150	160	1086	280	400	595	200	150	550	450	318	25	100	83	22	19	260	298	334	540	455	6	467
	BNMS4 150/315A/A	200	150	160	1158	280	400	618	200	150	550	450	356	55	100	103	22	19	260	298	385	540	460	8	544
BNMS4 150/400C/A	200	150	160	1218	315	450	653	200	150	550	450	356	25	100	103	22	19	295	328	410	540	461	8		
BNMS4 150/400B/A	200	150	160	1257	315	450	725	200	150	550	450	406	25	100	100	22	24	295	328	454	540	461	8		
BNMS4 150/400A/A	200	150	160	1330	315	450	748	200	150	550	450	457	45	100	100	22	24	295	328	482	625	535	6		

Features

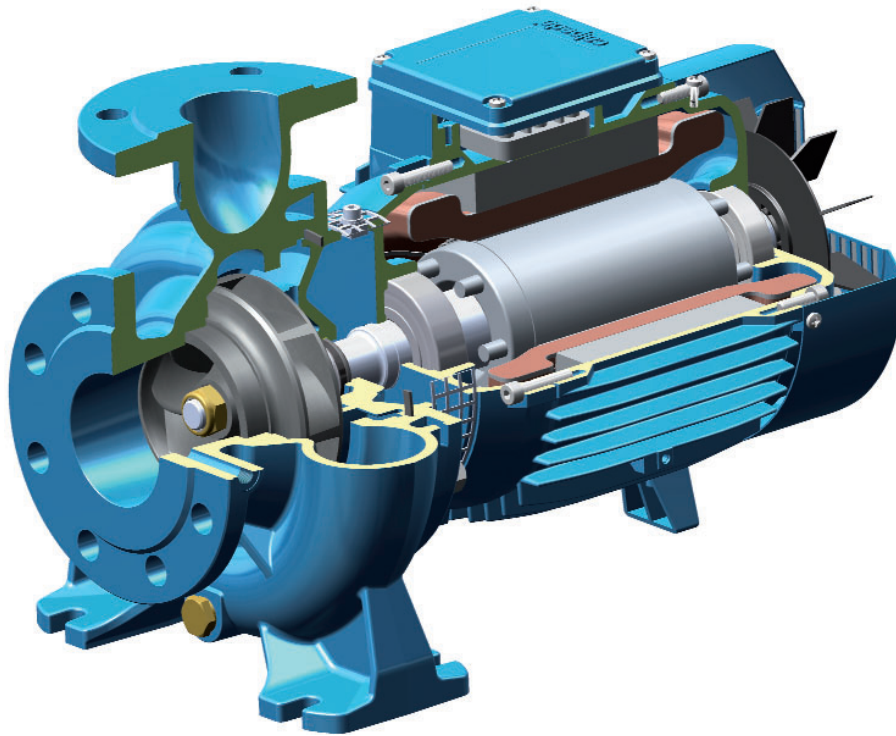

Cutting edge hydraulics

The geometry of the impeller and the pump casing are optimized to achieve maximum efficiency and the best suction capability.

Flexible

The option to choose between cast iron and bronze materials for the hydraulic parts in contact with the pumped liquid allows NM4 series pumps to be selected for use with different types of liquids.

Compact Design

The compact design allows for easy installation even in confined spaces.

Exclusive design

An innovative, patented guard prevents contact with rotating parts, providing protection to the end user whilst allowing for inspection of the mechanical seal.

Reliable

The bearing and shaft are designed to ensure the reduction of the stress, providing high reliability under all operating conditions.

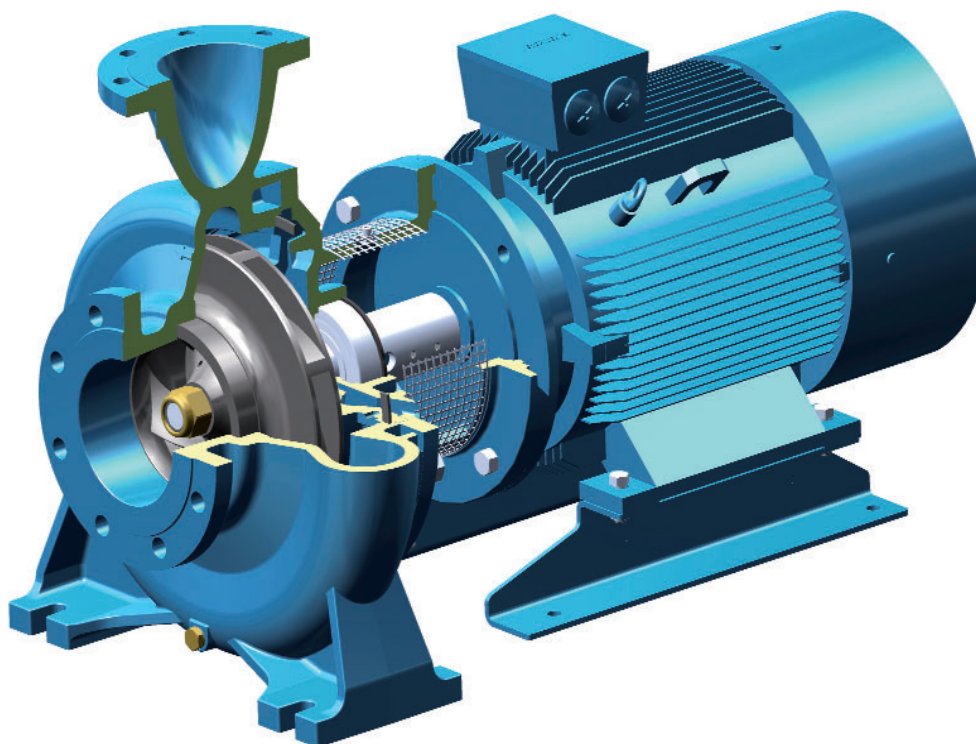
Features**Cutting edge hydraulics**

The geometry of the impeller and the pump casing are optimized to achieve maximum efficiency and the best suction capability.

Flexibility

The option to choose between cast iron and bronze materials for the hydraulic parts in contact with the pumped liquid allows NMS4 series pumps to be selected for use with different types of liquids.

New lantern bracket construction

The lantern brackets incorporate a thrust bearing on the hydraulic side which guarantees the elimination of additional loads on the motor bearings. The flange is sized to be used with standard motors B35.

Exclusive design

An innovative, patented guard prevents contact with rotating parts, proving protection to the end user whilst allowing for inspection of the mechanical seal.

Simplified motor maintenance

The presence of the thrust bearing on the hydraulic side makes it easier to remove the motor, facilitating maintenance operations and eliminating the risks of damage to the hydraulic parts.