

FAMCO
هایپر صنعت



water passion

تهران، کیلومتر ۲۱ بزرگراه لشگری (جاده مخصوص کرج)، روبروی پالایشگاه نفت پارس، پلاک ۱۲

Fax: ۰۲۱ - ۴۴۹۹۴۶۴۲ Tel: ۰۲۱ - ۴۸۰۰۰۰۴۹

E-mail: info@famcocorp.com

1959

WHO WE ARE

WE WANT TO CONTINUE THAT WHICH WAS STARTED MANY YEARS AGO BY VINICIO METTIFOGO, FOUNDER AND PIONEER.

Calpeda is a family owned company with an history of 61 years.

Today, we are a reality that has evolved over the years, always looking to the future with a spirit that has brought us to being a respected reference point in the great world of water.

Our history has taken our tradition and strength to you, acknowledged for our professionalism, quality, reliability and service.

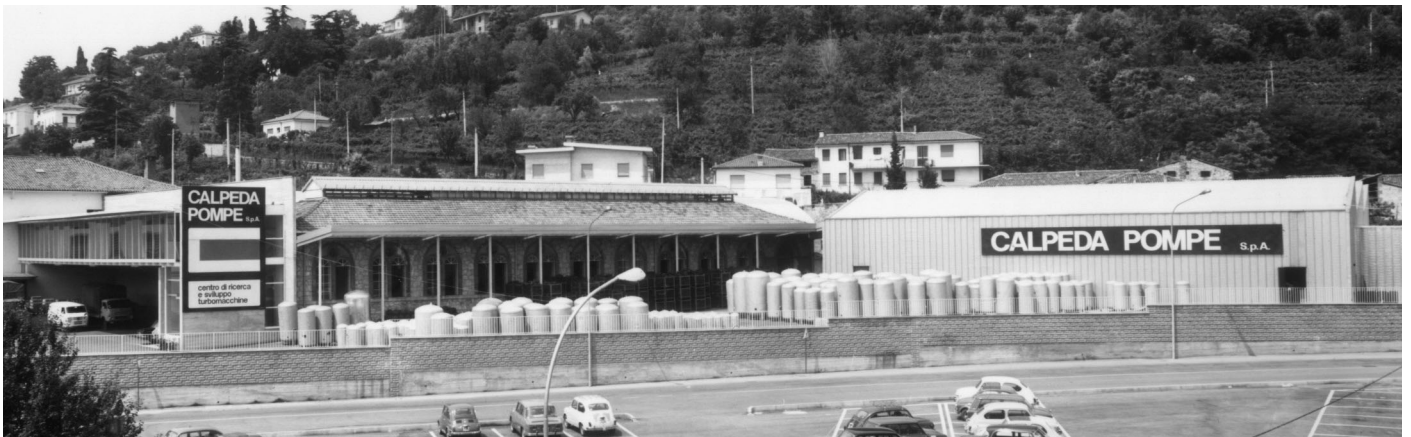

2020

CALPEDA TODAY

Employees: 250
Offices: Montorso V. (Vicenza) Italy
Main factory: 30,000 sq. metres (covered)
Types of pumps: more than 2,000
Power outputs: from 0.5 kW to 200 kW



GM

Submersible Pumps



GMV

Submersible pumps with vortex impeller in cast iron EN-GJL-250

pag. 264

GMVS

Submersible pumps with vortex impeller in cast iron with polyurethane coating

pag. 271

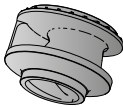
GMC

Submersible pumps with single channel impeller in cast iron EN-GJL-250

pag. 273

GMN

Submersible pumps with channels impeller in cast iron EN-GJL-250

pag. 282

GMG

Submersible pumps with grinder in cast iron EN-GJL-250

pag. 296

I-GMV

Submersible pumps with vortex impeller in stainless steel AISI316

pag. 300

I-GMC

Submersible pumps with single channel impeller in stainless steel AISI316

pag. 300

I-GMN

Submersible pumps with channels impeller in stainless steel AISI316

pag. 300

B-GMV

Submersible pumps with vortex impeller in Marine Bronze B10

pag. 311

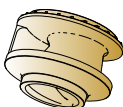
B-GMC

Submersible pumps with single channel impeller in Marine Bronze B10

pag. 311

B-GMN

Submersible pumps with channels impeller in Marine Bronze B10

pag. 311

A new series of submersible pumps with high efficiency hydraulics designed to move slurry, sewage and industrial process fluids.

The range covers a wide field of use with head up to 75 m And flows up to 2300 m³/h, with a maximum solid passage up to 140 mm keeping the risk of blockage to a minimum.

Dimensionally designed for heavy demand, even on critical applications.

Explosion proof version on request.

Pump designation

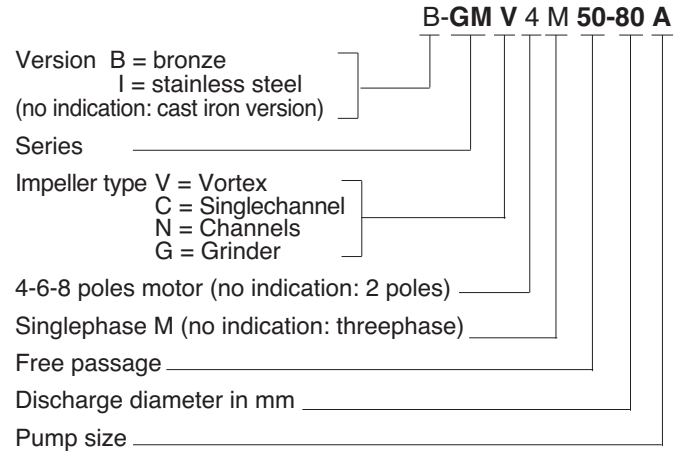

Coverage chart

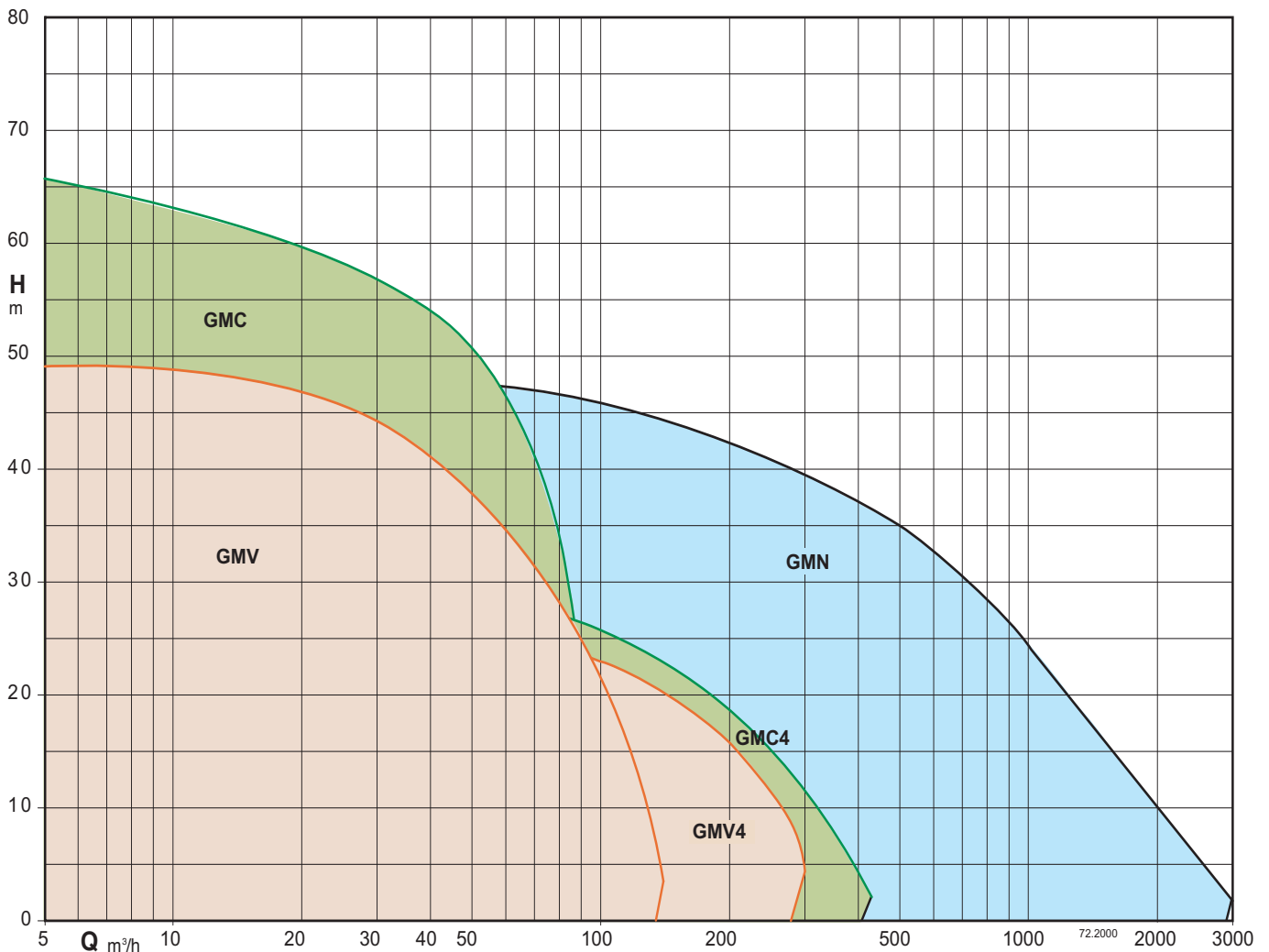

Tolerances according to UNI EN ISO 9906:2012



Construction

Submersible pumps with vortex impeller.
Twin mechanical seal with oil chamber.
Delivery connection DN 80-100-150.

Applications

Suitable to pump slurry and sewage waters with the presence of solid and filamentous parts in suspension, they are in particular pointed out for emptying septic tanks in the domestic, residential and industrial installations.

Solid passage diameter from 50 to 100 mm.

Operating conditions

Liquid temperature up to 40 °C.
Maximum immersion depth: 20 m (with suitable cable length).
Continuous duty (with pump immersed at minimum level).

Main materials

Pump casing: cast iron EN-GJL-250
Impeller: cast iron EN-GJL-250+Ni
Motor casing: cast iron EN-GJL-250
Motor cover: cast iron EN-GJL-250
Shaft: stainless steel AISI 420B
Mechanical seal motor side: graphite/ceramic
Mechanical seal pump side: silicon carbide/silicon carbide

Motor

2 or 4 poles induction, 50Hz
Three-phase version: 400V ± 10%
400/690V ± 10%

Insulation Class: H
Protection degree: IP 68
N° of starting x hour: max 15 with regular intervals
Cable: H07RN-F, length 10 m
Other models: contact our sale office
Classification scheme IE3.

Coverage chart

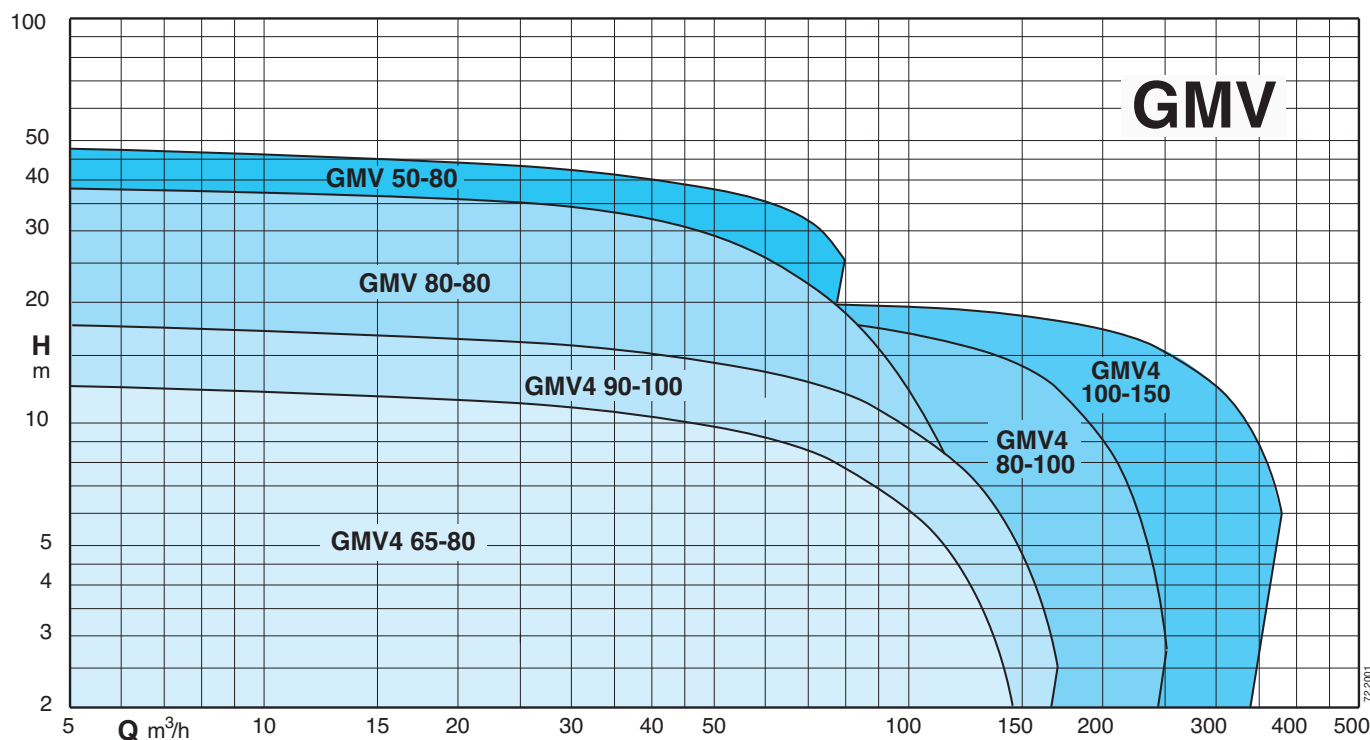

Technical data

TYPE	P ₂ kW	I _N A	Power Supply	r.p.m.	Starting	DN mm	Free passage Ø mm	Thermal protector	Humidity probe	ATEX Eex
GMV 50-80F/A	3,1	5,8	3~ 400V	2850	D.O.L.	80	50	NO	NO	✓
GMV 50-80E/A	3,9	7,2	3~ 400V	2850	D.O.L.	80	50	NO	NO	✓
GMV 50-80D/A	5	9,1	3~ 400/690V	2850	Y/Δ	80	50	●	●	✓
GMV 50-80C/A	5,7	10,4	3~ 400/690V	2850	Y/Δ	80	50	●	●	✓
GMV 50-80B/A	16,6	29,8	3~ 400/690V	2850	Y/Δ	80	50	●	●	✓
GMV 50-80A/A	18,2	32,6	3~ 400/690V	2850	Y/Δ	80	50	●	●	✓
GMV 70-80B/B	8,2	14,7	3~ 400/690V	2850	Y/Δ	80	70	●	●	✓
GMV 70-80A/B	9	16,2	3~ 400/690V	2850	Y/Δ	80	70	●	●	✓
GMV 80-80B/A	14,9	26,8	3~ 400/690V	2850	Y/Δ	80	80	●	●	✓
GMV 80-80A/A	18,2	32,6	3~ 400/690V	2850	Y/Δ	80	80	●	●	✓
GMV 80-80S/A	22,4	38,9	3~ 400/690V	2850	Y/Δ	80	80	●	●	✓
GMV4 65-80D/A	2,3	4,4	3~ 400V	1450	D.O.L.	80	65	NO	NO	✓
GMV4 65-80C/A	3,2	6,2	3~ 400V	1450	D.O.L.	80	65	NO	NO	✓
GMV4 65-80B/A	3,5	6,8	3~ 400/690V	1450	Y/Δ	80	65	●	●	✓
GMV4 65-80A/A	4,9	9,9	3~ 400/690V	1450	Y/Δ	80	65	●	●	✓
GMV4 90-100B/A	6	11,5	3~ 400/690V	1450	Y/Δ	100	90	●	●	✓
GMV4 90-100A/A	7,5	14,3	3~ 400/690V	1450	Y/Δ	100	90	●	●	✓
GMV4 80-100C/A	10	19	3~ 400/690V	1450	Y/Δ	100	80	●	●	✓
GMV4 80-100B/A	12,9	24,1	3~ 400/690V	1450	Y/Δ	100	80	●	●	✓
GMV4 80-100A/A	16	29,7	3~ 400/690V	1450	Y/Δ	100	80	●	●	✓
GMV4 80-100S/A	27	49,6	3~ 400/690V	1450	Y/Δ	100	80	●	●	✓
GMV4 100-150E/A	27	49,6	3~ 400/690V	1450	Y/Δ	150	100	●	●	✓

P₂ Rated power output

I_N Rated current

● Standard

✓ ATEX Eex Version on demand

Characteristic curves

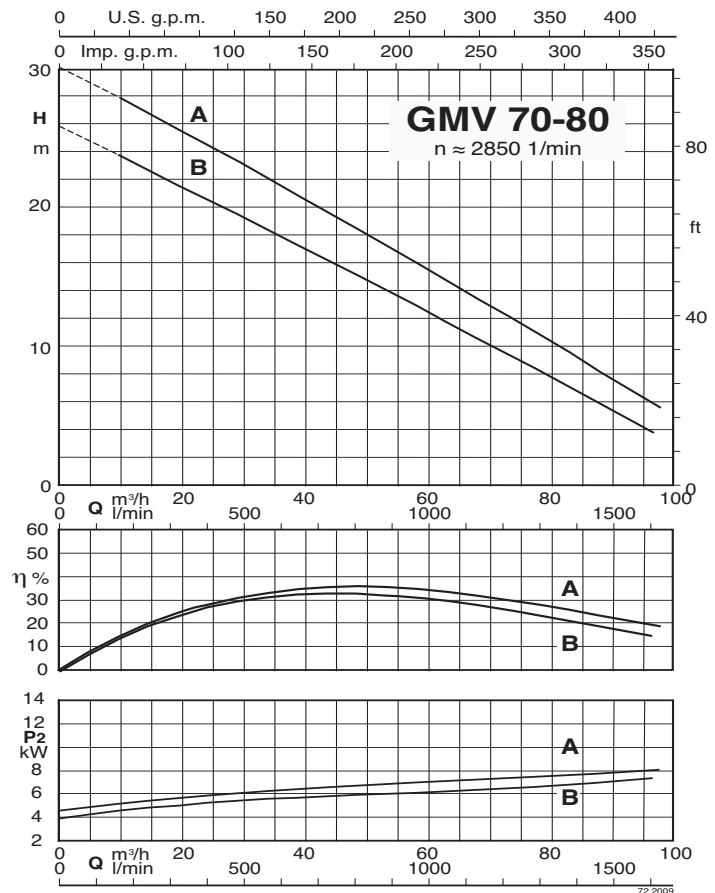
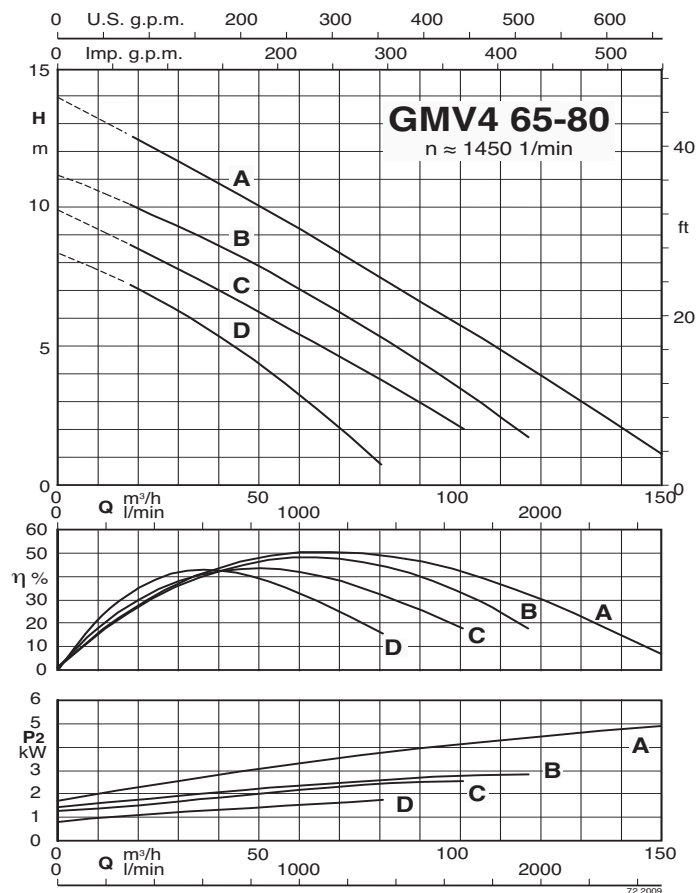
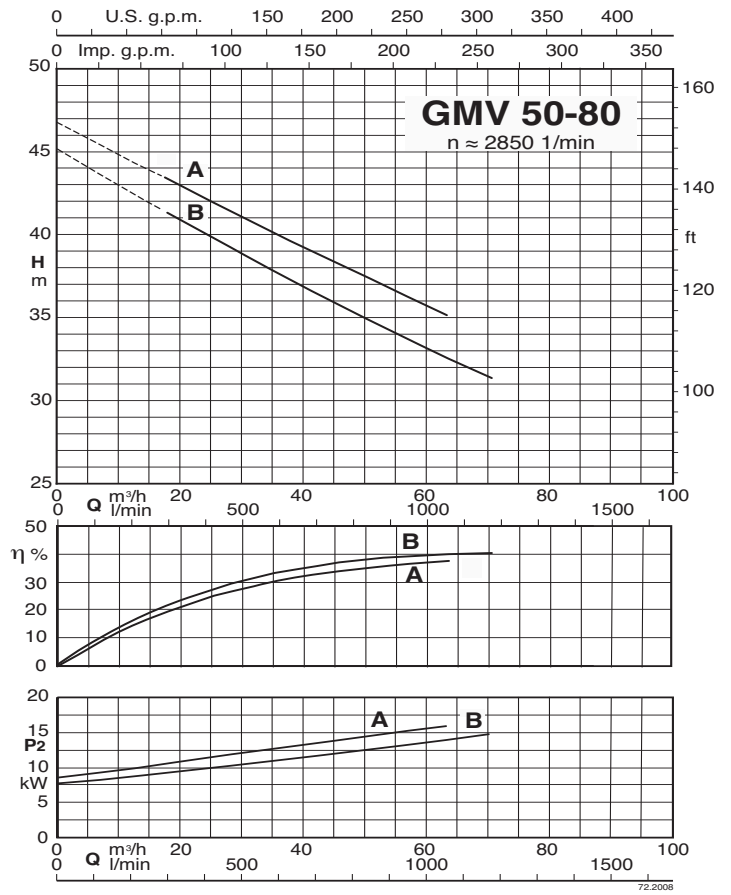
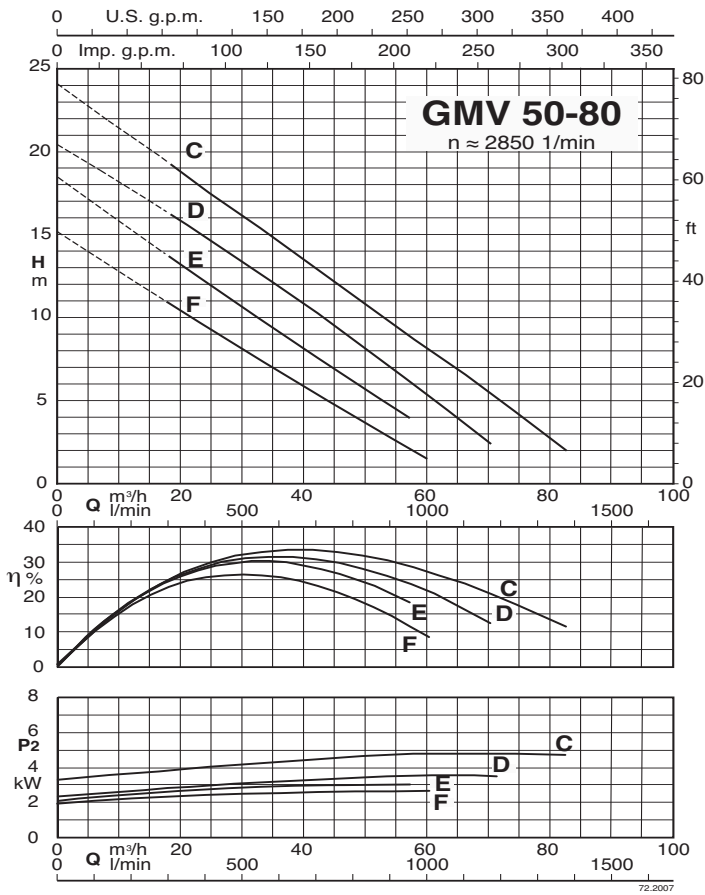

Characteristic curves

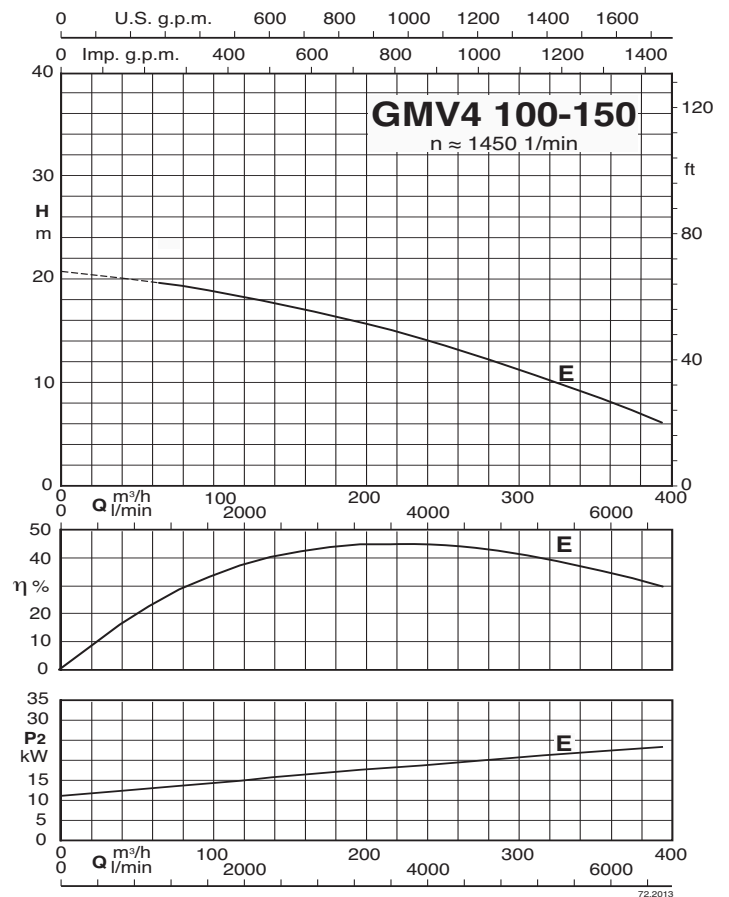
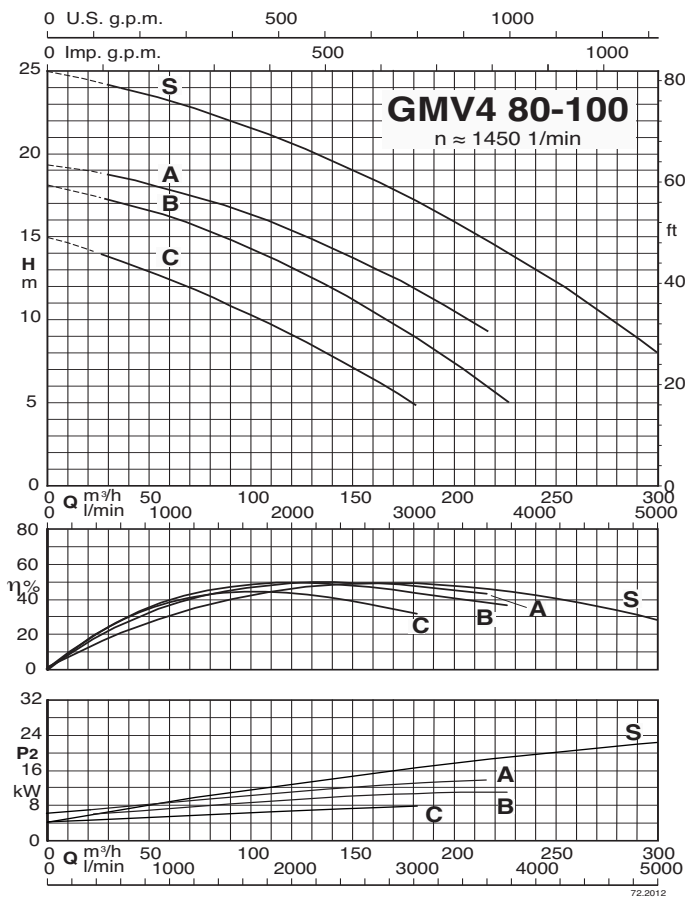
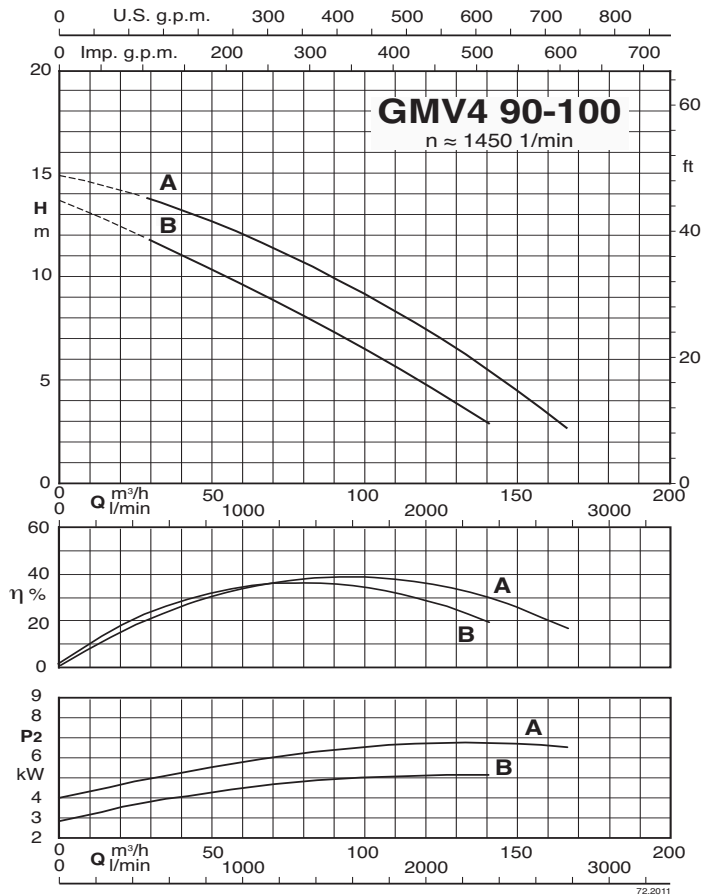
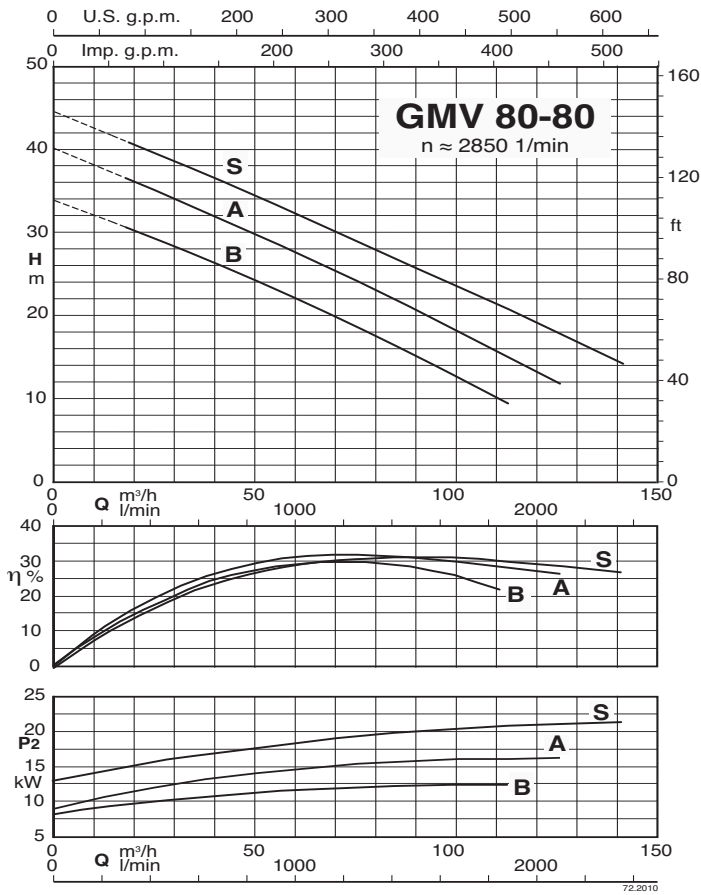

Dimensions and weights

GMV 50-80
GMV 80-80
GMV4 65-80

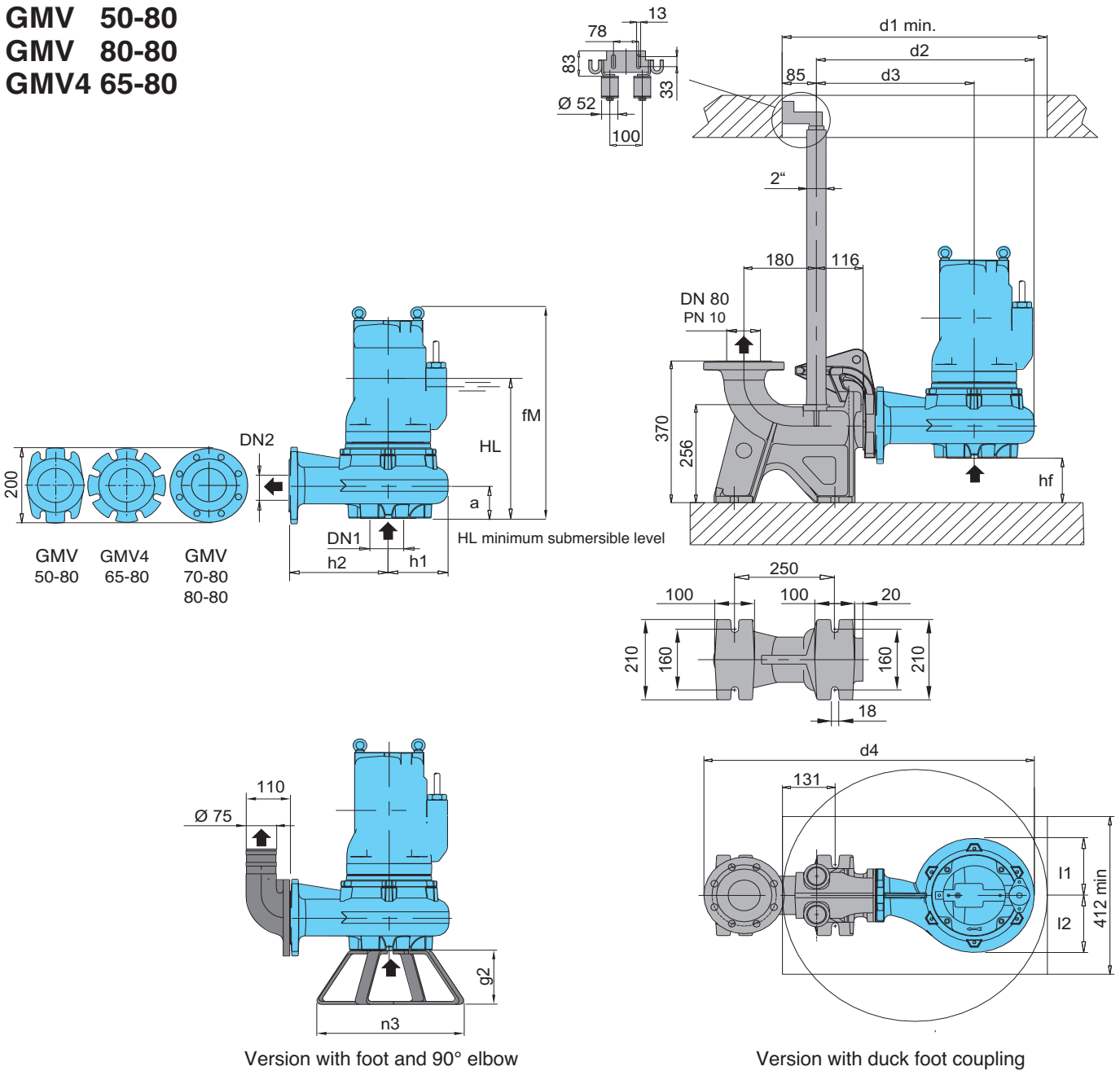

TYPE	EN 1092-2 PN 10		Dimensions mm														Weight kg
	DN1	DN2	fM	HL	hf	a	l1	l2	d1	d2	d3	d4	h1	h2	n3	g2	
GMV 50-80F/A	80	80	487	347	116	84	149	149	660	541	392	821	149	246	364	140	62
GMV 50-80E/A			553	375	116	84	149	149	660	541	392	821	149	246	364	140	76
GMV 50-80D/A			867	516	122	78	164	164	800	593	428	873	185	241	500	150	196
GMV 50-80C/A	80	80	829	500	65	135	167	167	800	633	446	913	185	280	400	140	165
GMV 50-80B/A			900	548	60	140	169	175	900	671	481	950	190	315	400	140	193
GMV 50-80A/A			1328	658	58	142	193	193	800	672	483	952	193	316	500	150	320
GMV4 65-80D/A	80	80	516	380	80	121	143	169	700	548	396	828	152	250	364	140	64
GMV4 65-80C/A			582	400	80	121	143	169	700	548	396	828	152	250	364	140	79
GMV4 65-80B/A																	
GMV4 65-80A/A																	

Dimensions and weights

GMV4 90-100 GMV4 80-100

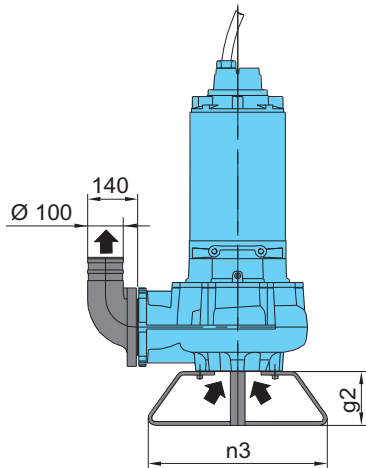
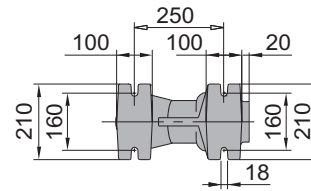
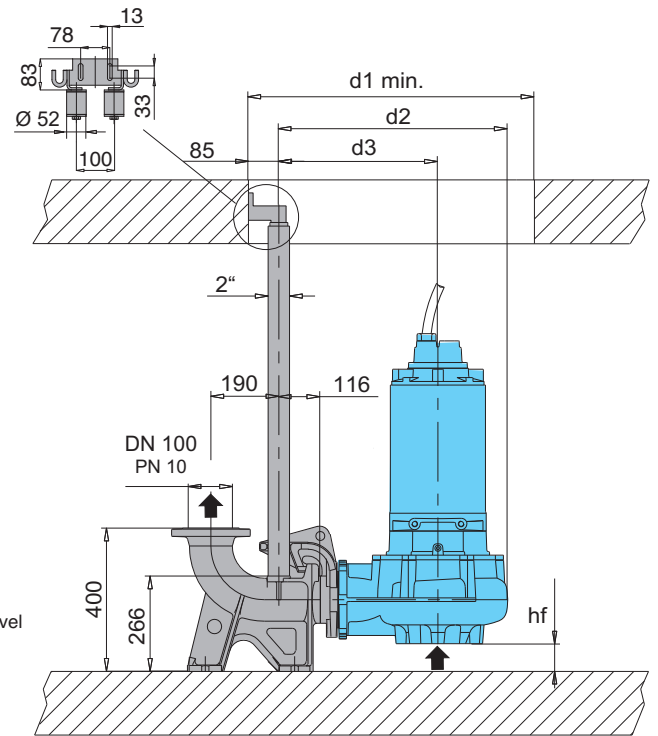
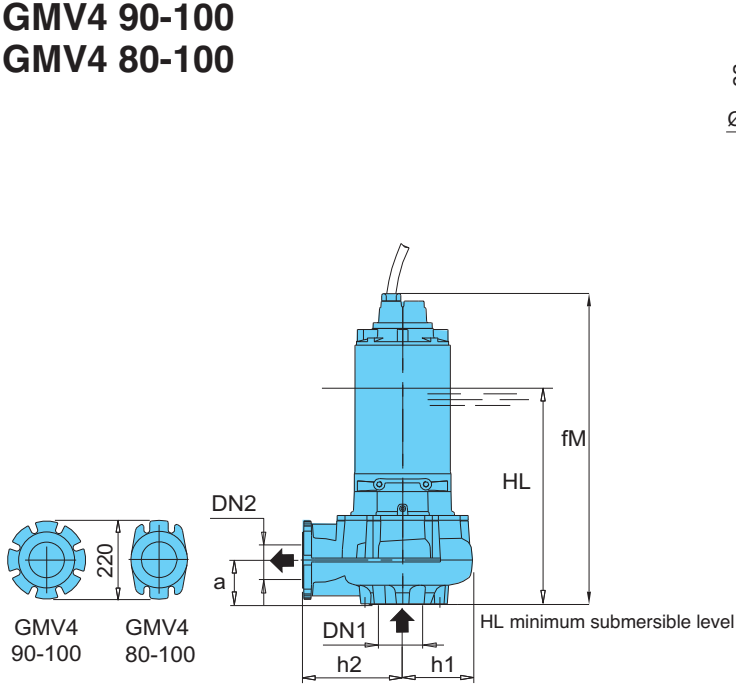

Version with foot and 90° elbow

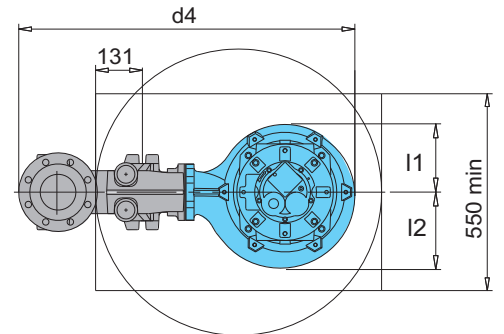

Version with duck foot coupling

TYPE	EN 1092-2 PN 10		Dimensions mm														Weight kg
	DN1	DN2	fM	HL	hf	a	l1	l2	d1	d2	d3	d4	h1	h2	n3	g2	
GMV4 90-100B/A	125	100	829	490	89	111	180	180	800	633	443	933	241	277	500	150	165
GMV4 90-100A/A																	
GMV4 80-100C/A	125	100	921	570	54	147	189	212	800	640	445	940	195	279	500	150	205
GMV4 80-100B/A																	
GMV4 80-100A/A																	
GMV4 80-100S/A	125	100	1343	670	54	146	193	212	800	640	441	936	200	280	500	150	325

Dimensions and weights

GMV4 100-150

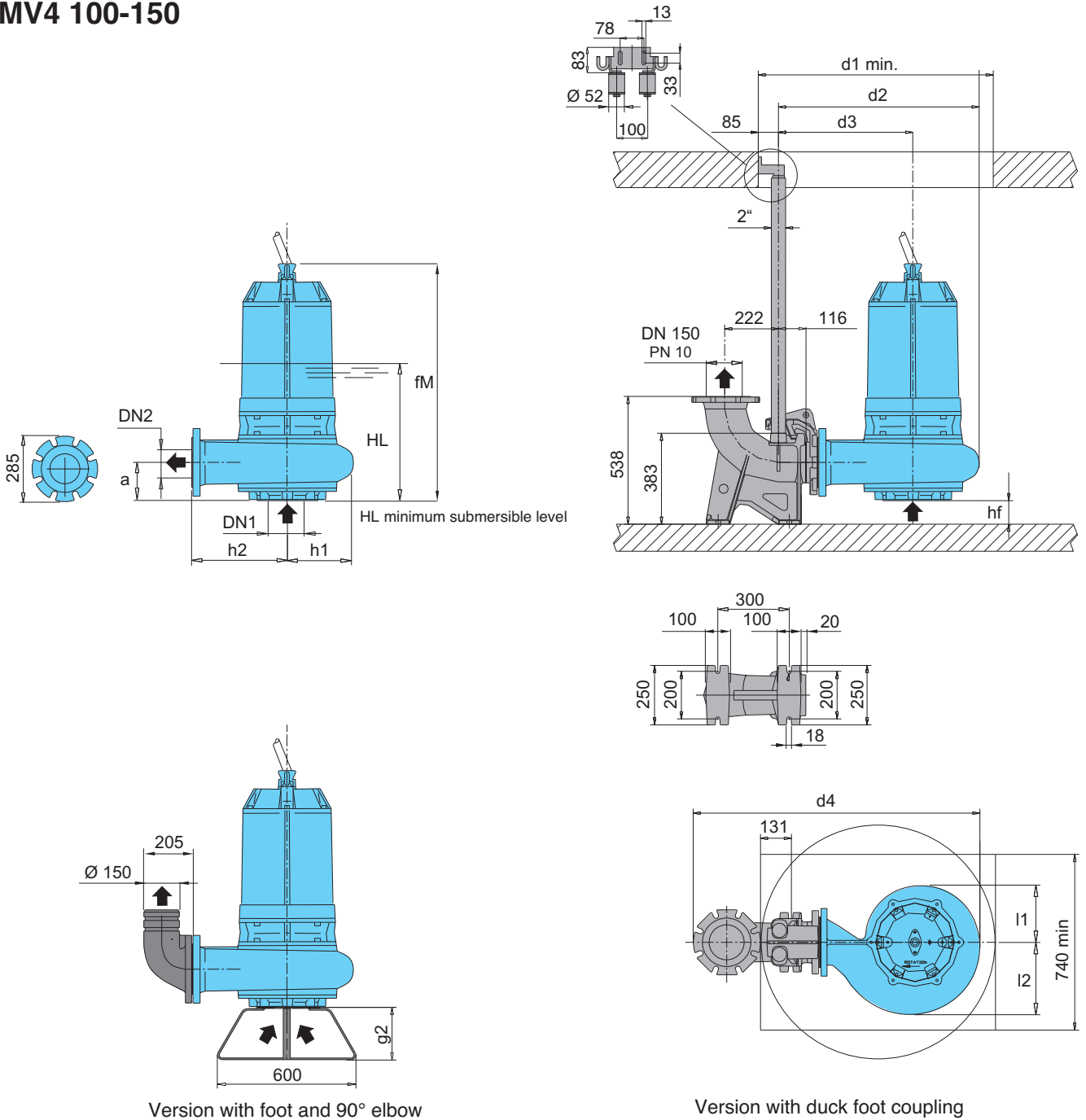

Version with foot and 90° elbow

Version with duck foot coupling

TYPE	EN 1092-2 PN 10		Dimensions mm															Weight kg
	DN1	DN2	fM	HL	hf	a	l1	l2	d1	d2	d3	d4	h1	h2	n3	g2		
GMV4 100-150E/A	150	150	1359	710	114	146	193	223	850	675	469	1040	206	280	600	225	355	



Construction

Submersible pumps with vortex impeller
Impeller in Polyurethane with a stainless steel core - Pump casing in Cast iron EN-GJL-250, with polyurethane coating for parts subject to high wear.
Twin mechanical seal with oil chamber.
Delivery connection DN 80.

Applications

The pumps are designed to suit applications in plants with an high sand presence, in marble work companies, in the ceramic industry, crystals machining or industrial processes handling abrasives liquids.
Solid passage diameter from 35 mm.

Operating conditions

Liquid temperature up to 40 °C.
Maximum immersion depth: 20 m (with suitable cable length).
Continuous duty (with pump immersed at minimum level).

Main materials

Pump casing: cast iron EN-GJL-250 with polyurethane coating
Impeller: Polyurethane with a stainless steel core
Motor casing: cast iron EN-GJL-250
Motor cover: cast iron EN-GJL-250
Shaft: stainless steel AISI 420B
Mechanical seal motor side: graphite/ceramic
Mechanical seal pump side: silicon carbide/silicon carbide

Motor

2 or 4 poles induction, 50Hz
Three-phase version: 400/690V ± 10%
Insulation Class: H
Protection degree: IP 68
N° of starting x hour: max 15 with regular intervals
Cable: H07RN-F, length 10 m
Other models: contact our sale office
Classification scheme IE3.

Coverage chart

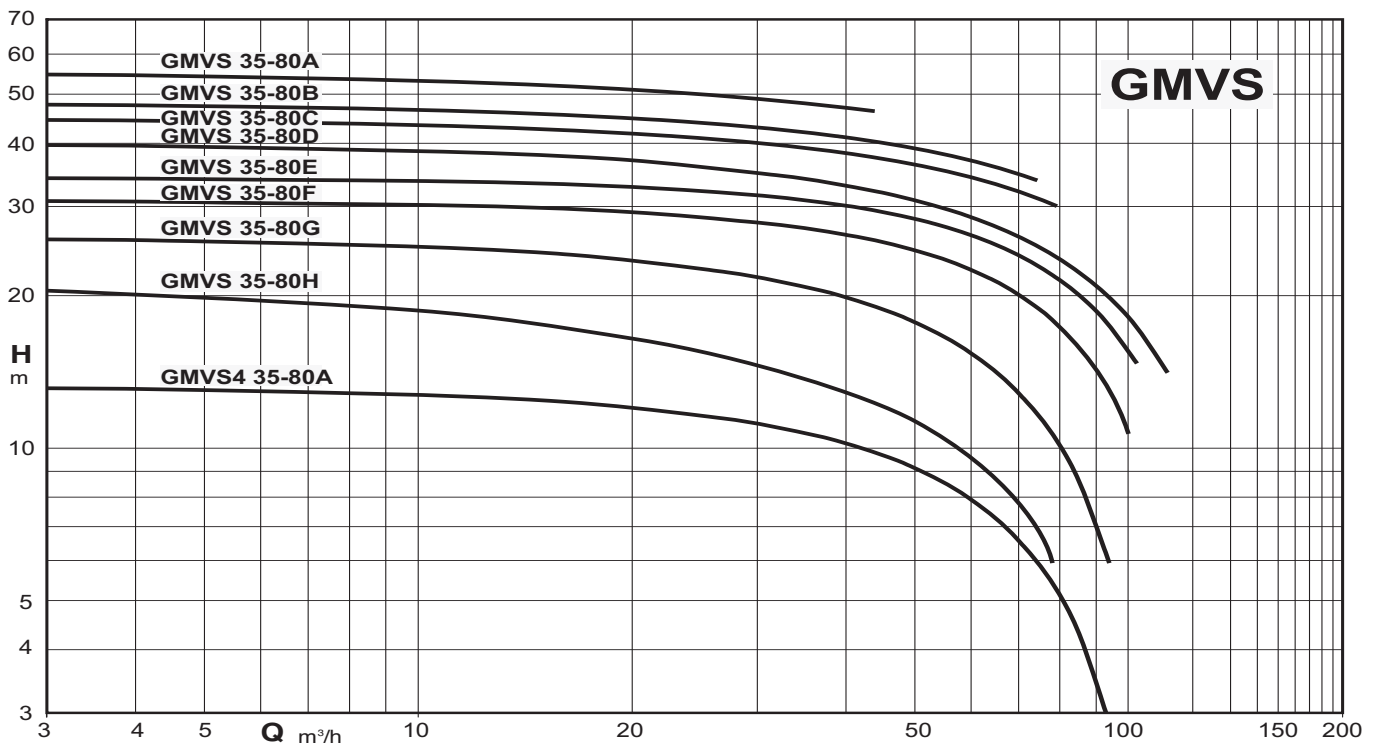

Technical data

TYPE	P ₂ kW	I _N A	Power Supply	r.p.m.	Starting	DN mm	Free passage Ø mm	Thermal protector	Humidity probe	ATEX Eex
GMVS 35-80H/A	9	16,2	3~ 400/690V	2850	Y/Δ	80	35	●	●	
GMVS 35-80G/A	12	24,7	3~ 400/690V	2850	Y/Δ	80	35	●	●	
GMVS 35-80F/A	16,6	29,8	3~ 400/690V	2850	Y/Δ	80	35	●	●	
GMVS 35-80E/A	16,6	29,8	3~ 400/690V	2850	Y/Δ	80	35	●	●	
GMVS 35-80D/A	16,6	29,8	3~ 400/690V	2850	Y/Δ	80	35	●	●	
GMVS 35-80C/A	16,6	29,8	3~ 400/690V	2850	Y/Δ	80	35	●	●	
GMVS 35-80B/A	16,6	29,8	3~ 400/690V	2850	Y/Δ	80	35	●	●	
GMVS 35-80A/A	16,6	29,8	3~ 400/690V	2850	Y/Δ	80	35	●	●	
GMVS4 35-80A/A	6	11,5	3~ 400/690V	1450	Y/Δ	80	35	●	●	

P₂ Rated power output

I_N Rated current

● Standard

✓ ATEX Eex Version on demand

Dimensions and weights

GMVS 35-80 GMVS4 35-80

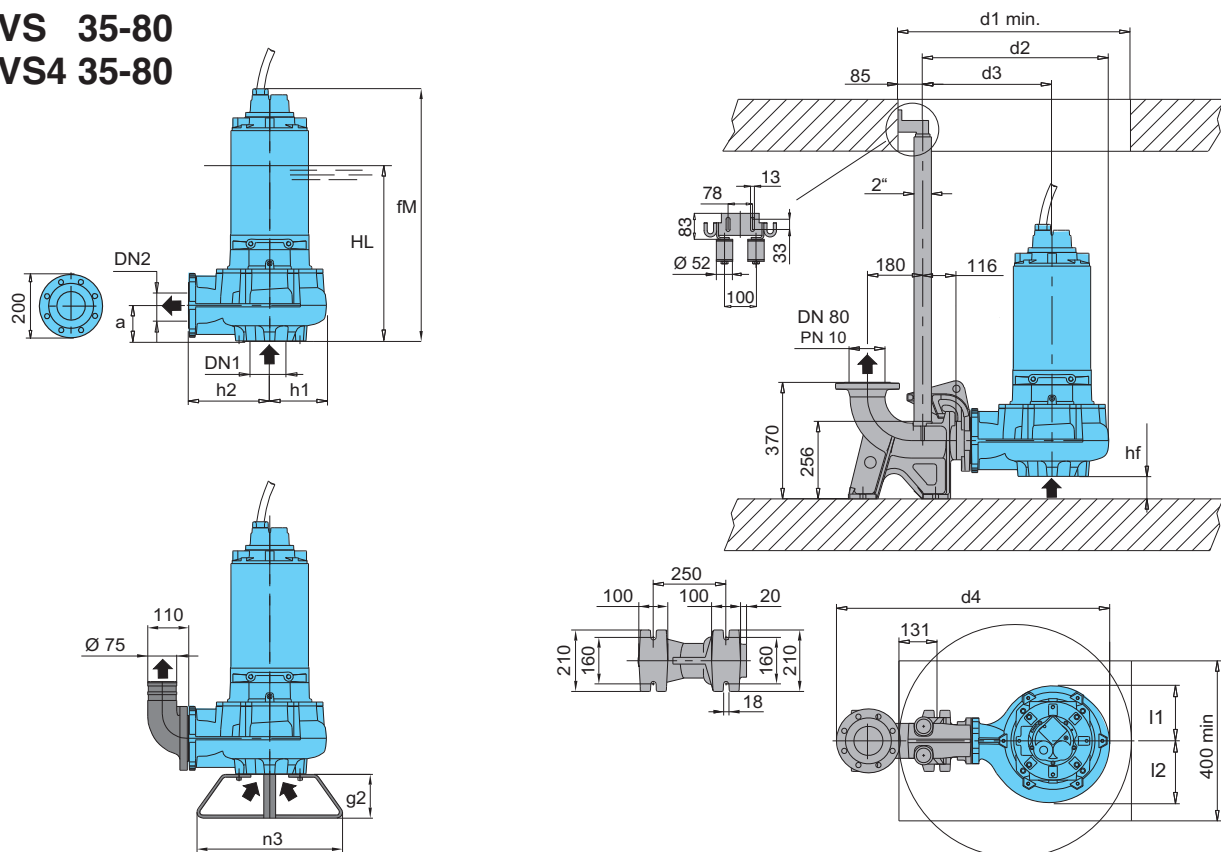

TYPE	EN 1092-2 PN 10		Dimensions mm														Weight kg
	DN1	DN2	fM	HL	hf	a	l1	l2	d1	d2	d3	d4	h1	h2	n3	g2	
GMVS 35-80H/A	80	80	796	468	122	78	165	165	800	593	408	873	185	242	400	140	165
GMVS 35-80G/A	80	80	867	514	124	100	165	165	800	593	408	873	185	242	500	150	191
GMVS 35-80F/A																	
GMVS 35-80E/A																	
GMVS 35-80D/A																	
GMVS 35-80C/A																	
GMVS 35-80B/A																	
GMVS 35-80A/A																	
GMVS4 35-80A/A	80	80	796	468	122	78	165	165	800	593	408	873	185	242	400	140	160



Construction

Submersible pumps with single channel impeller.
Twin mechanical seal with oil chamber (lip-seal motor side up to 1,4 kW).
Delivery connection DN 50-65-80-100-150

Applications

Suitable to pump slurry, sewage, waste water (non-corrosive).
In industrial and residential installations and drainag applications
Solid passage from 40 to 100mm

Operating conditions

Liquid temperature up to 40 °C.
Maximum immersion depth: 20 m (with suitable cable length).
Continuous duty (with pump immersed at minimum level).

Main materials

Pump casing: cast iron EN-GJL-250 - Impeller: cast iron EN-GJL-250+Ni
Motor casing, Motor cover: cast iron EN-GJL-250
Motor shaft: stainless steel AISI 420B
Lip seal made of nitrile up to 1,4 kW
Mechanical seal motor side: graphite/ceramic over 1,4 kW
Mechanical seal pump side: silicon carbide/silicon carbide

Motor

2 or 4 poles induction, 50Hz
Single-phase version: 230V ± 10%, with float switch and built-in capacitor.
Three-phase version: 400V ± 10%,
400/690V ± 10%
Insulation class: H
Protection degree: IP 68
N° of starting x hour: max 15 with regular intervals
Cable: H07RN-F, length 10 m
Other models: contact our sale office
Classification scheme IE3.

Coverage chart

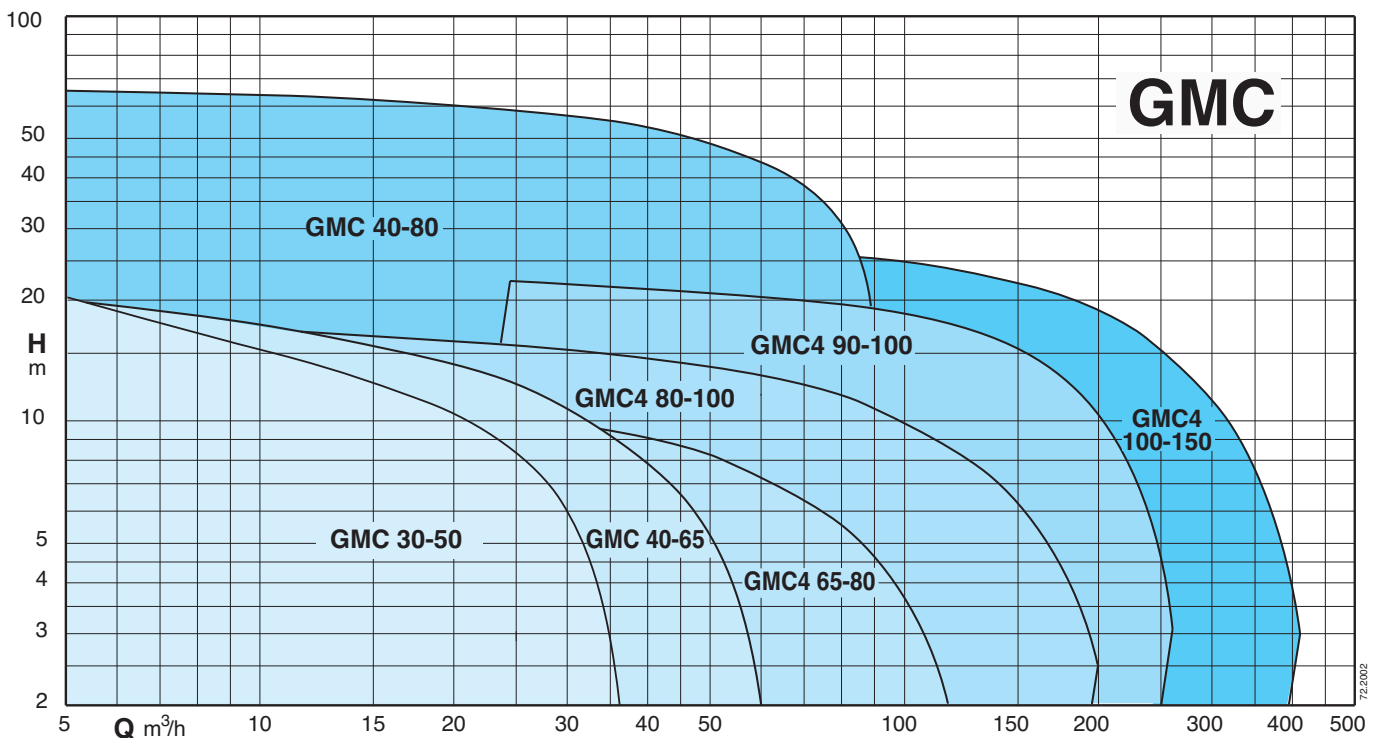

Technical data

TYPE	P ₂ kW	I _N A	Power Supply	r.p.m.	Starting	DN mm	Free passage Ø mm	Thermal protector	Humidity probe	ATEX Eex
GMC 30-50B/A	1,4	8,4	1~ 230V	2850	D.O.L.	50	30	●	NO	
GMC 30-50B/A	1,9	3,5	3~ 400V	2850	D.O.L.	50	30	NO	NO	
GMC 30-50A/A	1,9	3,5	3~ 400V	2850	D.O.L.	50	30	NO	NO	
GMC 40-65B/A	1,9	11,4	1~ 230V	2850	D.O.L.	65	40	NO	NO	✓
GMC 40-65B/A	2,4	4,5	3~ 400V	2850	D.O.L.	65	40	NO	NO	✓
GMC 40-65A/A	2,4	4,5	3~ 400V	2850	D.O.L.	65	40	NO	NO	✓
GMC 40-80C/A	13,8	24,8	3~ 400/690V	2850	Y/Δ	80	40	●	●	✓
GMC 40-80B/A	16,6	29,8	3~ 400/690V	2850	Y/Δ	80	40	●	●	✓
GMC 40-80A/A	18,2	32,6	3~ 400/690V	2850	Y/Δ	80	40	●	●	✓
GMC4M 65-80C/A	1,2	6,9	1~ 230V	1450	D.O.L.	80	65	●	NO	✓
GMC4 65-80C/A	1,6	3,1	3~ 400V	1450	D.O.L.	80	65	NO	NO	✓
GMC4 75-80A/A	2,8	5,4	3~ 400V	1450	D.O.L.	80	75	NO	NO	✓
GMC4 80-100C/A	3,9	7,9	3~ 400/690V	1450	Y/Δ	100	80	●	●	✓
GMC4 80-100B/A	3,9	7,9	3~ 400/690V	1450	Y/Δ	100	80	●	●	✓
GMC4 80-100A/A	7,1	13,5	3~ 400/690V	1450	Y/Δ	100	80	●	●	✓
GMC4 90-100B/A	10	19	3~ 400/690V	1450	Y/Δ	100	90	●	●	✓
GMC4 90-100A/A	14,4	26,7	3~ 400/690V	1450	Y/Δ	100	90	●	●	✓
GMC4 100-150C/B	12,9	24,1	3~ 400/690V	1450	Y/Δ	150	100	●	●	✓
GMC4 100-150B/B	15	27,8	3~ 400/690V	1450	Y/Δ	150	100	●	●	✓
GMC4 100-150A/B	17,8	33,3	3~ 400/690V	1450	Y/Δ	150	100	●	●	✓

P₂ Rated power output

I_N Rated current

● Standard

✓ ATEX Eex Version on demand

Characteristic curves

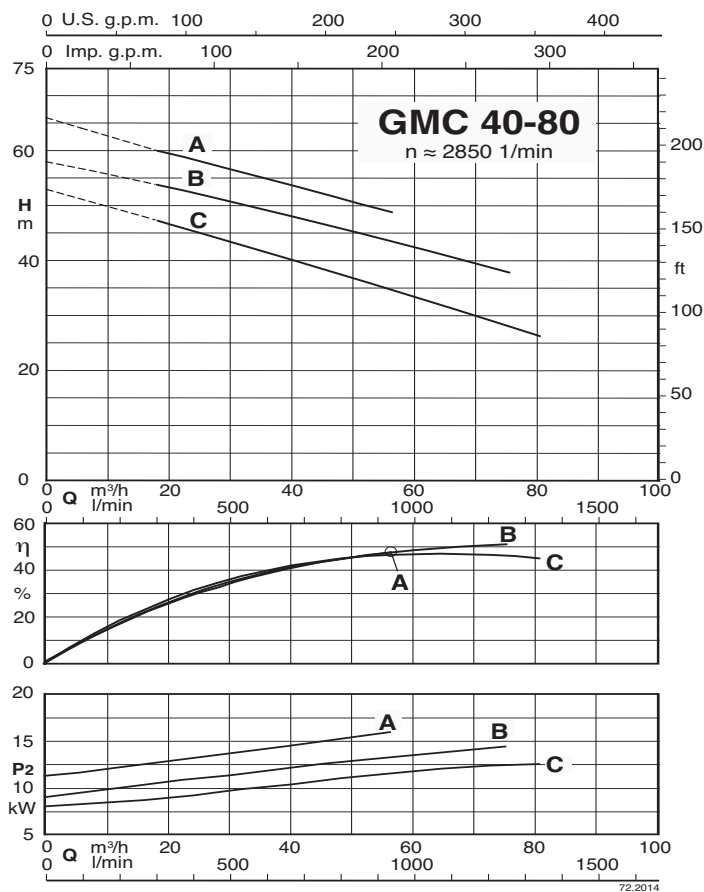
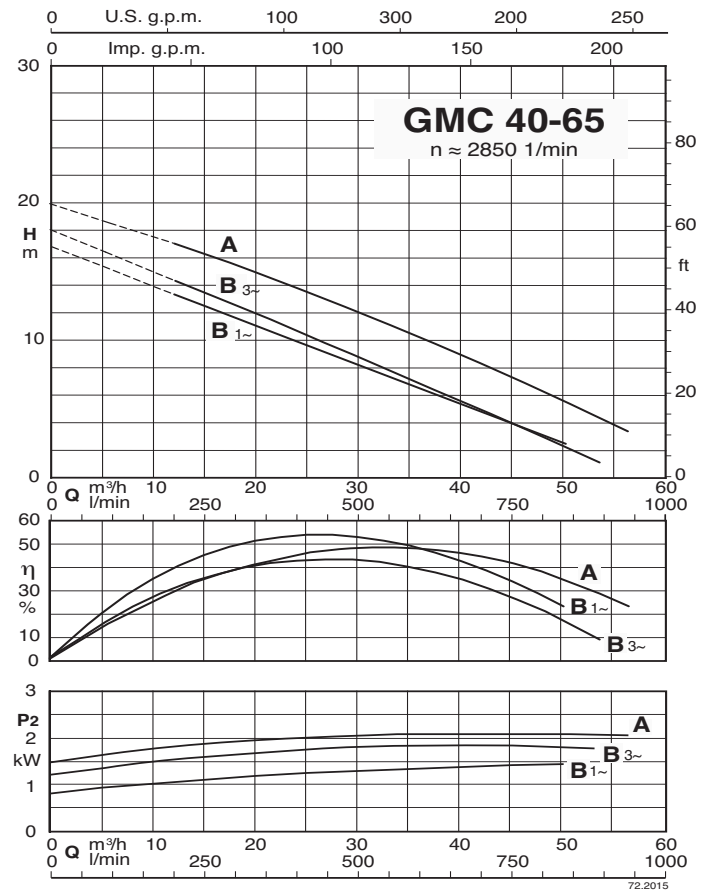
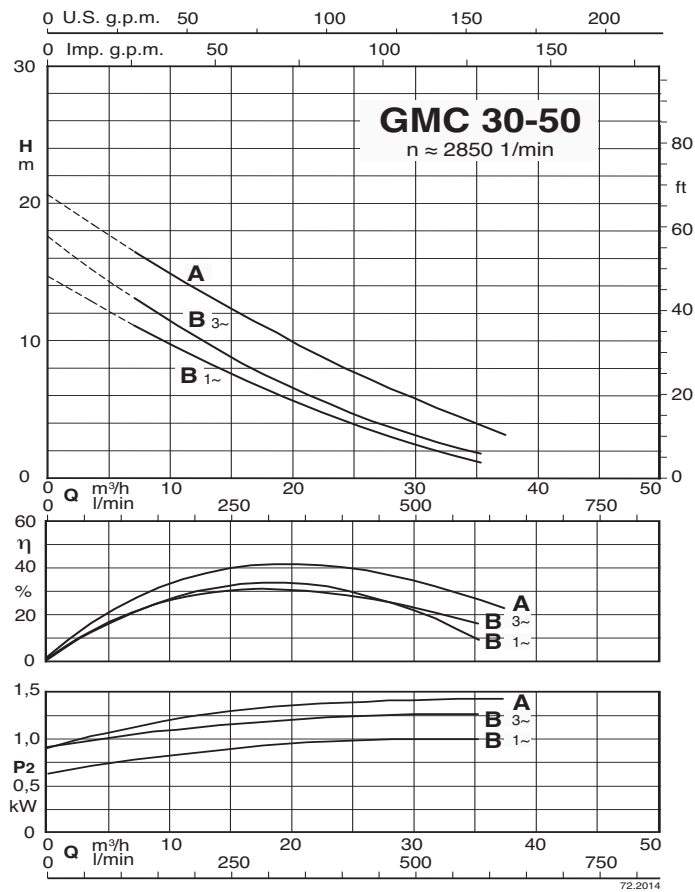

Characteristic curves

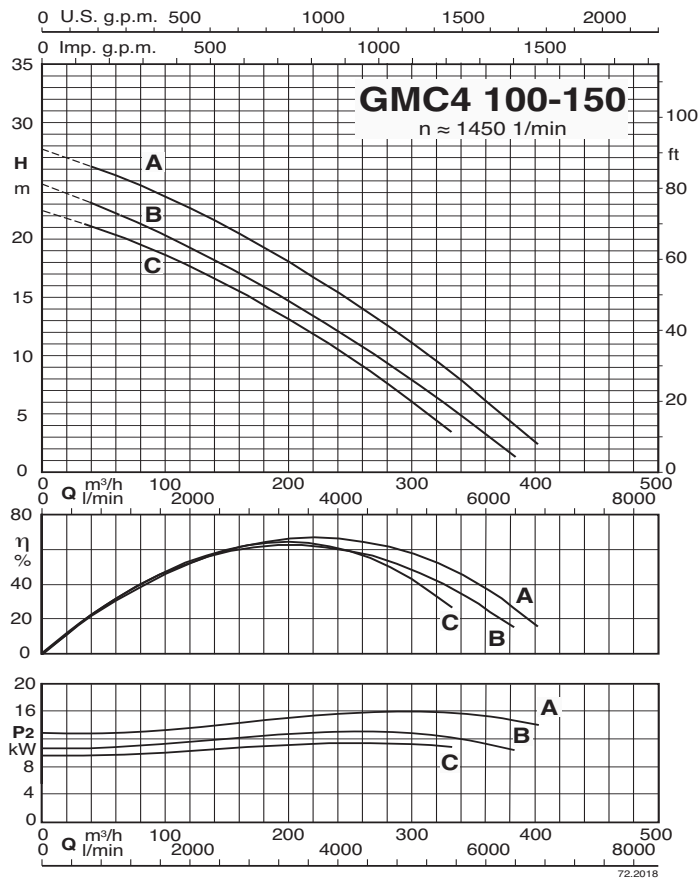
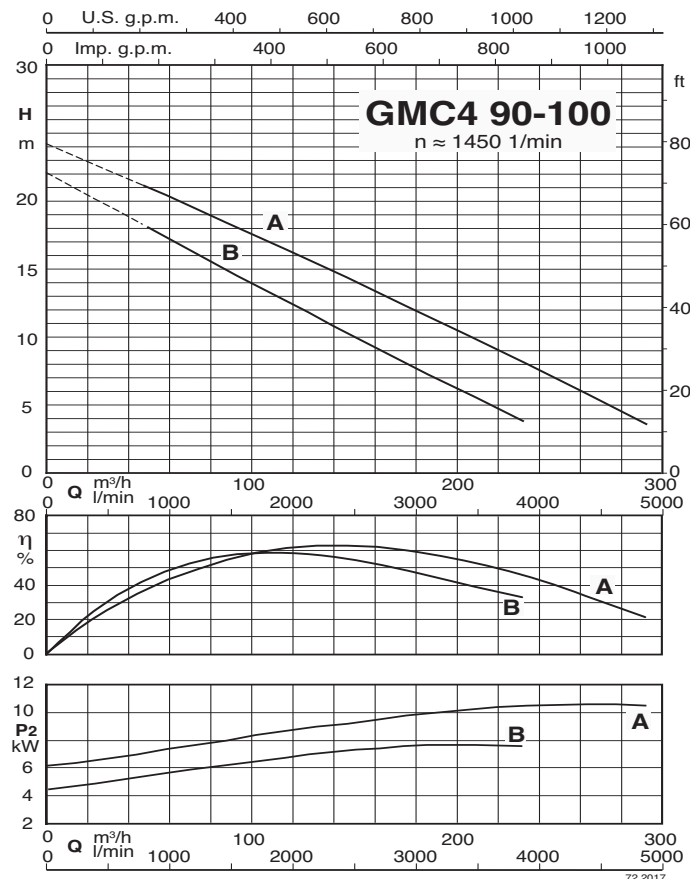
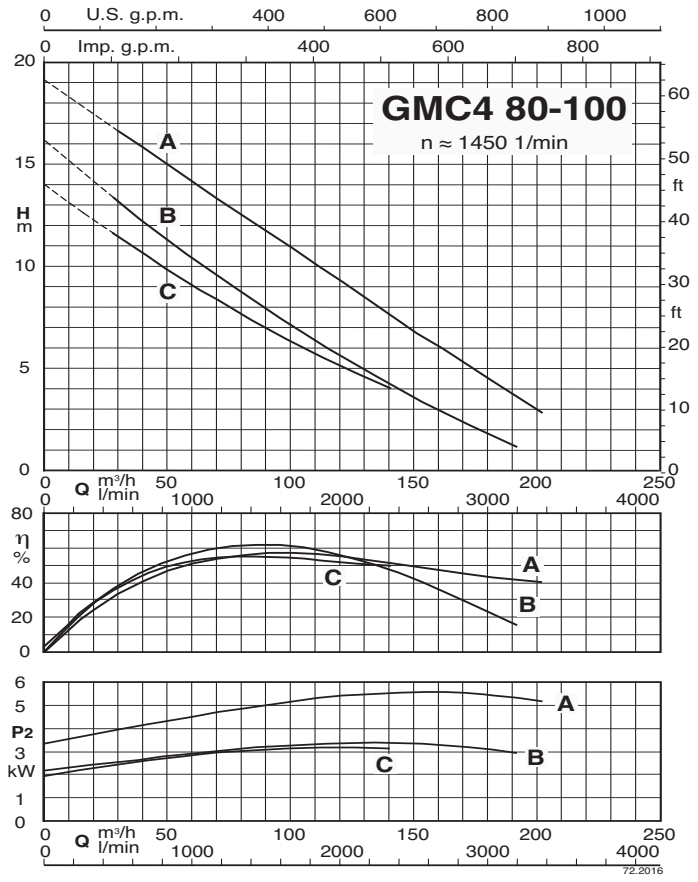
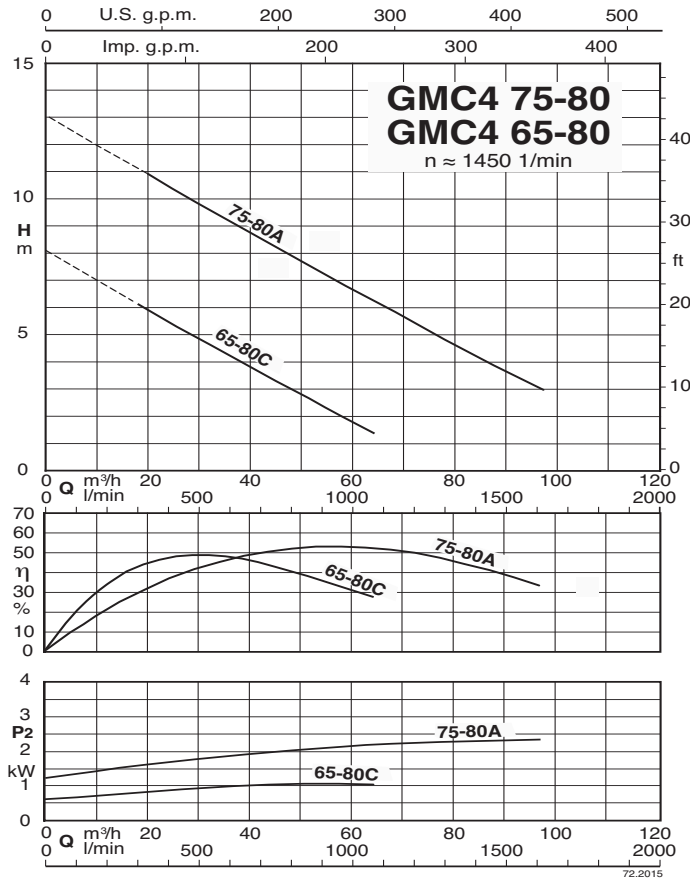

Dimensions and weights

GMC 30-50

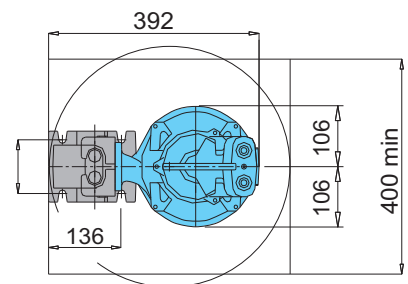
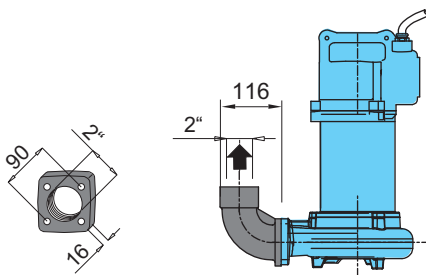
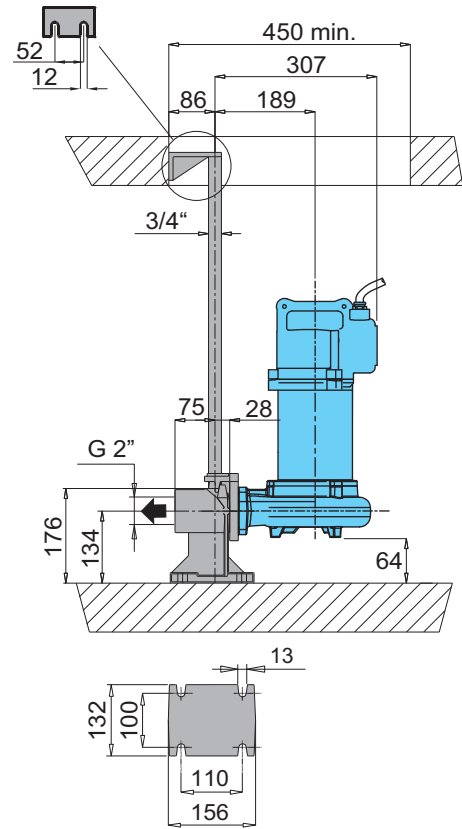
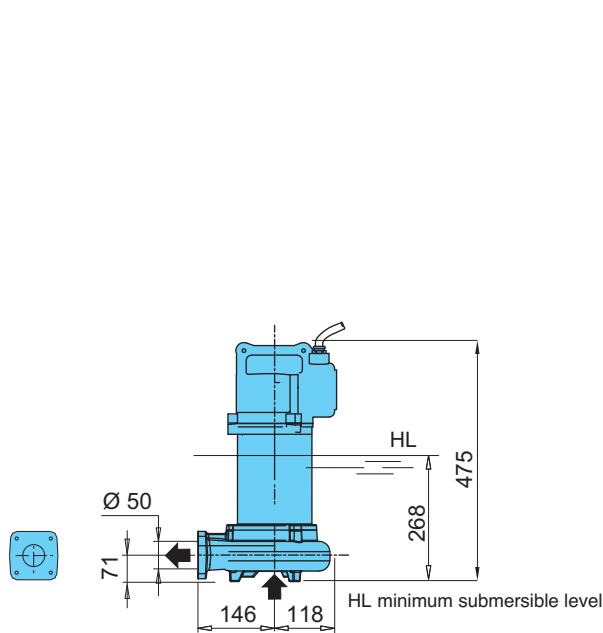

Version with threaded flange and 90° elbow

Version with duck foot coupling

TYPE	Weight kg
GMCM 30-50B	31
GMC 30-50B	
GMC 30-50A	

Dimensions and weights

GMC 40-65

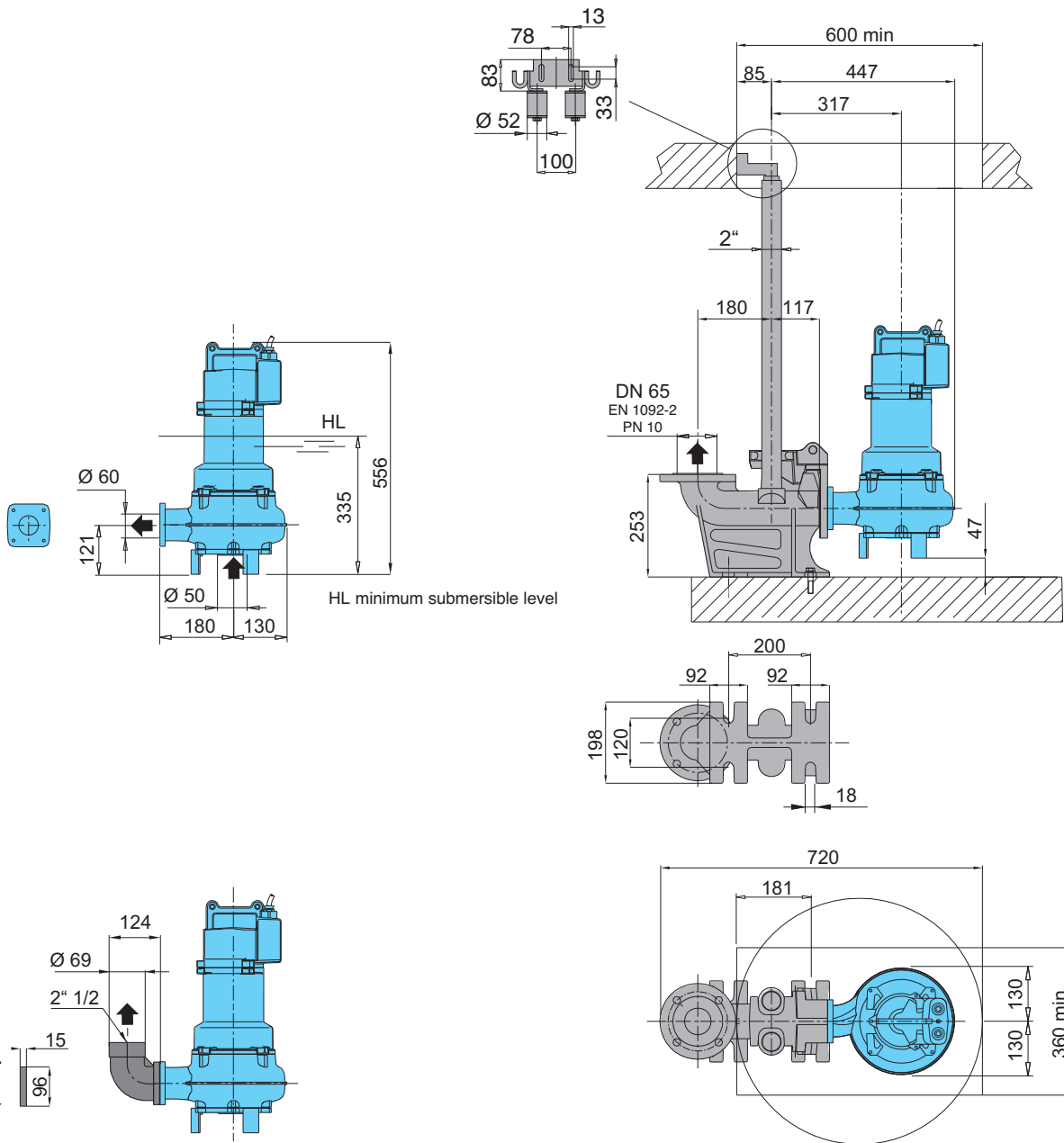

Version with threaded flange and 90° elbow

Version with duck foot coupling

TYPE	Weight kg
GMCM 40-65B	45
GMC 40-65B	
GMC 40-65A	

Dimensions and weights

- GMC 40-80**
- GMC4M 65-80**
- GMC4 65-80**
- GMC4 75-80**

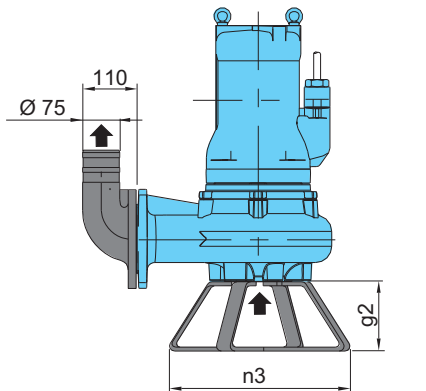
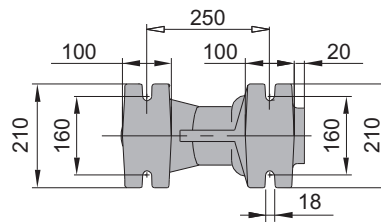
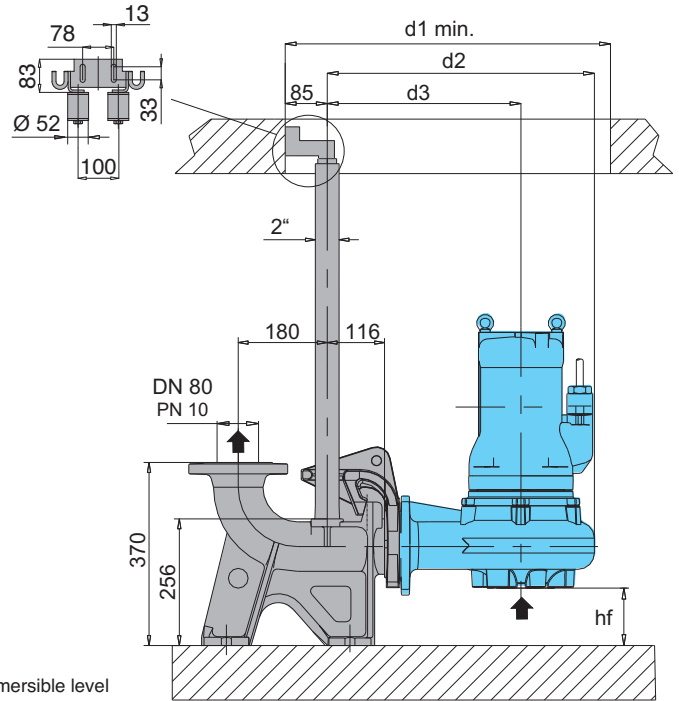
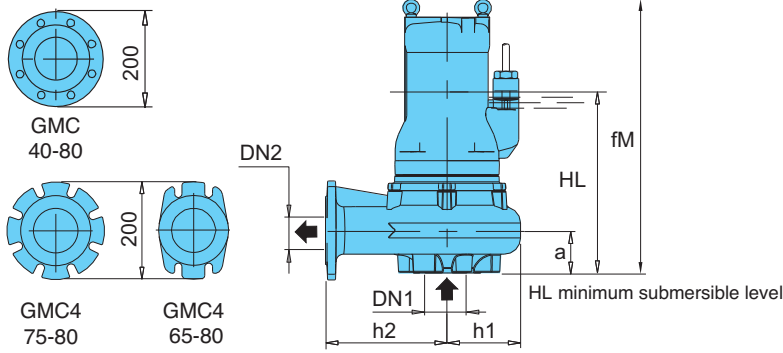

Version with foot and 90° elbow

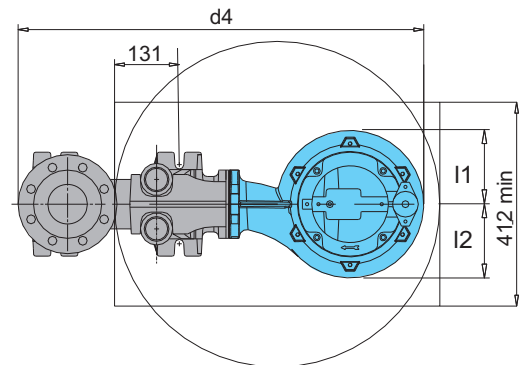

Version with duck foot coupling

TYPE	EN 1092-2 PN 10		Dimensions mm														Weight kg
	DN1	DN2	fM	HL	hf	a	l1	l2	d1	d2	d3	d4	h1	h2	n3	g2	
GMC 40-80C/A	80	80	890	523	85	116	168	168	750	603	416	883	187	250	500	150	195
GMC 40-80B/A																	
GMC 40-80A/A																	
GMC4M 65-80C/A	80	80	533	330	104	100	132	132	658	498	366	775	132	200	364	140	49
GMC4 65-80C/A																	
GMC4 75-80A/A																	
GMC4 75-80A/A	80	80	516	380	80	121	143	169	700	548	396	828	152	250	364	140	67

Dimensions and weights

GMC4 80-100

GMC4 90-100

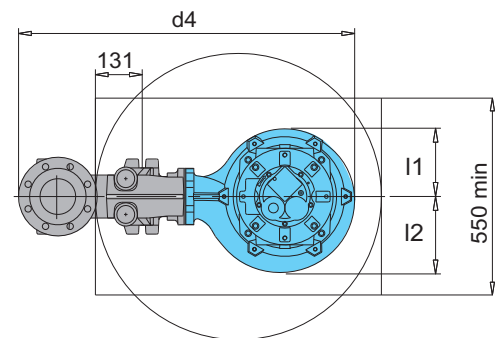
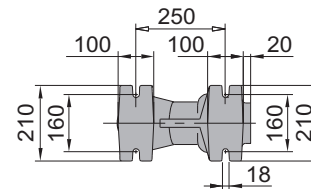
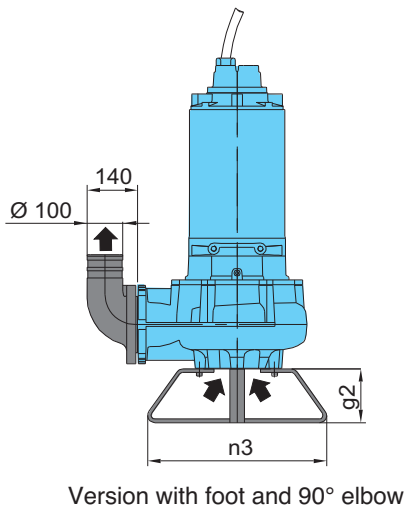
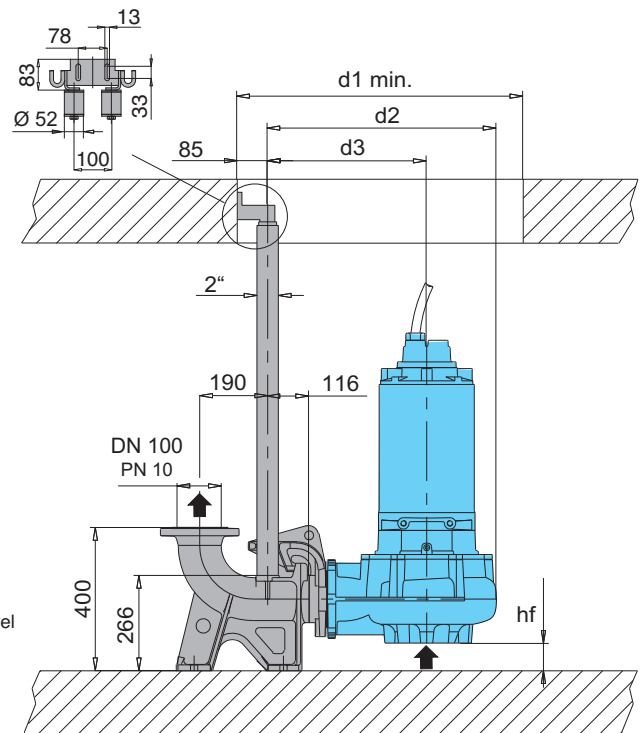
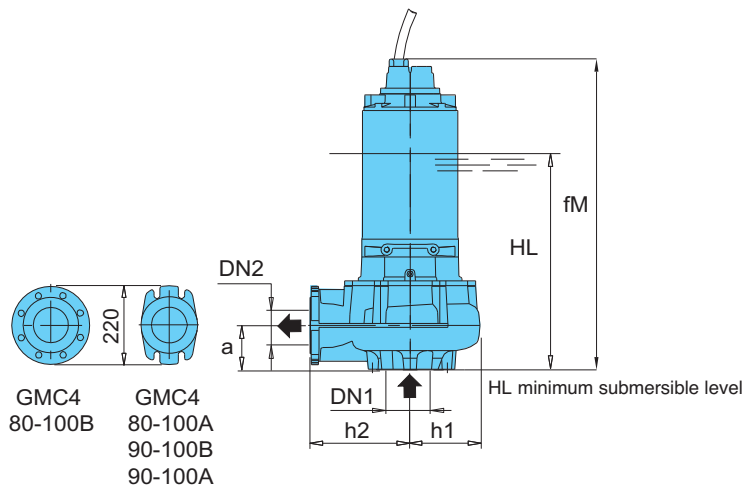

TYPE	EN 1092-2 PN 10		Dimensions mm														Weight kg
	DN1	DN2	fM	HL	hf	a	l1	l2	d1	d2	d3	d4	h1	h2	n3	g2	
GMC4 80-100C/A GMC4 80-100B/A	125	100	597	420	62	138	180	231	850	673	466	973	207	300	500	150	117
GMC4 80-100A/A	125	100	852	520	54	147	189	212	800	640	445	940	195	279	500	150	170
GMC4 90-100B/A GMC4 90-100A/A	125	100	920	570	54	147	189	212	800	640	445	940	195	279	500	150	204

Dimensions and weights

GMC4 100-150

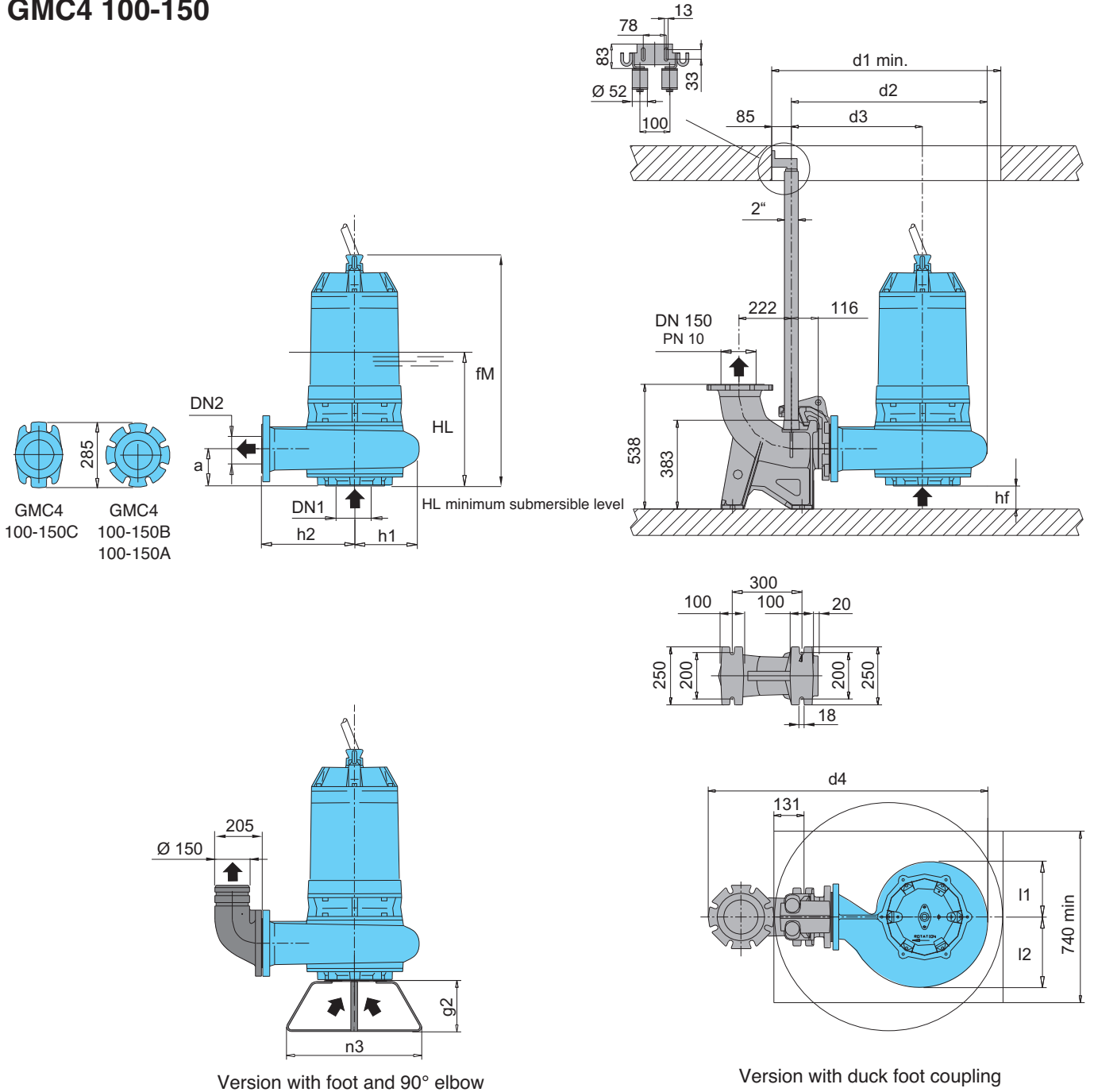

TYPE	EN 1092-2 PN 10		Dimensions mm														Weight kg
	DN1	DN2	fM	HL	hf	a	l1	l2	d1	d2	d3	d4	h1	h2	n3	g2	
GMC4 100-150C/B	150	150	1013	630	80	180	239	304	990	840	566	1122	273	400	225	600	313
GMC4 100-150B/B	150	150	1273	660	80	180	239	304	990	840	566	1208	273	400	225	500	375
GMC4 100-150A/B																	



Construction

Submersible pumps with channels impeller.
Twin mechanical seal with oil chamber.
Delivery connection DN 65-80-100-150-200-250-300.

Applications

Suitable to pump slurry, sewage and waste water (non-corrosive) with solids in suspension.
For industrial and residential installations and general drainage applications.
They are ideal for applications with smaller solids.
Solid passage from 30 to 140 mm

Operating conditions

Liquid temperature up to 40 °C.
Maximum immersion depth: 20 m (with suitable cable length).
Continuous duty (with pump immersed at minimum level).

Main materials

Pump casing: cast iron EN-GJL-250
Impeller: cast iron EN-GJL-250+Ni
Motor casing: cast iron EN-GJL-250
Motor cover: cast iron EN-GJL-250
Shaft: stainless steel AISI 420B
Mechanical seal motor side: graphite/ceramic
Mechanical seal pump side: silicon carbide/silicon carbide

Motor

2-4-6 or 8 poles induction, 50Hz
Three-phase version: 400V ± 10%,
400/690V ± 10%

Insulation class: H
Protection degree: IP 68
N° of starting x hour: max 15 with regular intervals
Cable: H07RN-F, length 10 m
Other models: contact our sale office
Classification scheme IE3.

Coverage chart

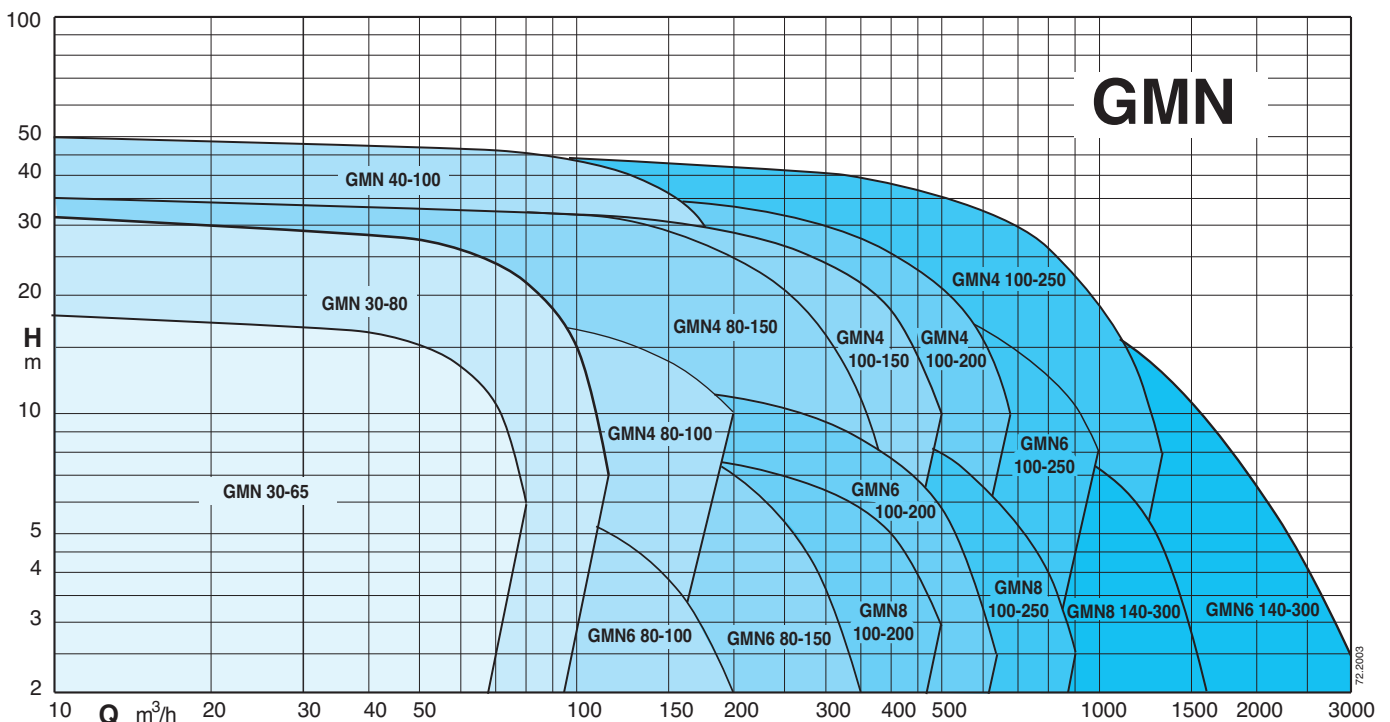

Technical data

TYPE	P ₂ kW	I _N A	Power Supply	r.p.m.	Starting	DN mm	Free passage Ø mm	Thermal protector	Humidity probe	ATEX Eex
GMN 30-65B/A	3,1	5,8	3~ 400V	2850	D.O.L.	65	30	NO	NO	✓
GMN 30-65A/A	3,6	6,6	3~ 400V	2850	D.O.L.	65	30	NO	NO	✓
GMN 30-80B/A	5	9,1	3~ 400/690V	2850	Y/Δ	80	30	●	●	✓
GMN 30-80A/A	6	10,9	3~ 400/690V	2850	Y/Δ	80	30	●	●	✓
GMN 30-80S/A	7,5	13,5	3~ 400/690V	2850	Y/Δ	80	30	●	●	✓
GMN 40-100D/A	12	21,7	3~ 400/690V	2850	Y/Δ	100	40	●	●	✓
GMN 40-100C/A	14,9	26,8	3~ 400/690V	2850	Y/Δ	100	40	●	●	✓
GMN 40-100B/A	16,6	29,8	3~ 400/690V	2850	Y/Δ	100	40	●	●	✓
GMN 40-100S/A	20	35,8	3~ 400/690V	2850	Y/Δ	100	40	●	●	✓
GMN4 80-100D/A	4,6	9,3	3~ 400/690V	1450	Y/Δ	100	80	●	●	✓
GMN4 80-100C/A	7,5	14,3	3~ 400/690V	1450	Y/Δ	100	80	●	●	✓
GMN4 80-100A/A	10	19	3~ 400/690V	1450	Y/Δ	100	80	●	●	✓
GMN6 80-100B/A	2,7	5,8	3~ 400V	950	D.O.L.	100	80	NO	NO	✓
GMN6 80-100A/A	2,8	6	3~ 400/690V	950	Y/Δ	100	80	●	●	✓
GMN6 80-150B/A	6	12	3~ 400/690V	950	Y/Δ	150	80	●	●	✓
GMN6 80-150A/A	8	15,8	3~ 400/690V	950	Y/Δ	150	80	●	●	✓
GMN6 100-150B/B	14	26,2	3~ 400/690V	950	Y/Δ	150	100	●	●	✓
GMN6 100-150A/B	12	22,9	3~ 400/690V	950	Y/Δ	150	100	●	●	✓
GMN4 80-150C/B	27	49,6	3~ 400/690V	1450	Y/Δ	150	80	●	●	✓
GMN4 80-150B/B	30	54,3	3~ 400/690V	1450	Y/Δ	150	80	●	●	✓
GMN4 100-150G/A	23	42,2	3~ 400/690V	1450	Y/Δ	150	100	●	●	✓
GMN4 100-150F/A	27	49,6	3~ 400/690V	1450	Y/Δ	150	100	●	●	✓
GMN4 100-150E/B	30	54,3	3~ 400/690V	1450	Y/Δ	150	100	●	●	✓
GMN4 100-150D/B	30	54,3	3~ 400/690V	1450	Y/Δ	150	100	●	●	✓
GMN4 100-150S/B	35,7	63,6	3~ 400/690V	1450	Y/Δ	150	100	●	●	✓
GMN4 100-200C/A	40	71,3	3~ 400/690V	1450	Y/Δ	200	100	●	●	✓
GMN4 100-200B/A	44	78,1	3~ 400/690V	1450	Y/Δ	200	100	●	●	✓
GMN4 100-200A/A	48	85,2	3~ 400/690V	1450	Y/Δ	200	100	●	●	✓
GMN4 100-250D/A	65	109,7	3~ 400/690V	1450	Y/Δ	250	100	●	●	✓
GMN4 100-250C/A	75	126,3	3~ 400/690V	1450	Y/Δ	250	100	●	●	✓
GMN4 100-250B/A	75	126,3	3~ 400/690V	1450	Y/Δ	250	100	●	●	✓
GMN4 100-250A/A	85	143,2	3~ 400/690V	1450	Y/Δ	250	100	●	●	✓
GMN6 100-200E/B	14	26,2	3~ 400/690V	950	Y/Δ	200	100	●	●	✓
GMN6 100-200D/B	14	26,2	3~ 400/690V	950	Y/Δ	200	100	●	●	✓
GMN6 100-250D/A	23	40,6	3~ 400/690V	950	Y/Δ	250	100	●	●	✓
GMN6 100-250C/A	29	52,8	3~ 400/690V	950	Y/Δ	250	100	●	●	✓
GMN6 100-250B/A	39,2	71	3~ 400/690V	950	Y/Δ	250	100	●	●	✓
GMN6 100-250A/A	39,2	71	3~ 400/690V	950	Y/Δ	250	100	●	●	✓
GMN6 140-300D/A	33,4	60,8	3~ 400/690V	950	Y/Δ	300	140	●	●	✓
GMN6 140-300C/A	39,2	71	3~ 400/690V	950	Y/Δ	300	140	●	●	✓
GMN6 140-300B/A	55,8	99	3~ 400/690V	950	Y/Δ	300	140	●	●	✓
GMN6 140-300A/A	65	115,3	3~ 400/690V	950	Y/Δ	300	140	●	●	✓
GMN8 100-200B/C	9,3	19,8	3~ 400/690V	750	Y/Δ	200	100	●	●	✓
GMN8 100-200A/A	9,3	19,8	3~ 400/690V	750	Y/Δ	200	100	●	●	✓
GMN8 100-250B/B	12,4	26,5	3~ 400/690V	750	Y/Δ	250	100	●	●	✓
GMN8 100-250A/C	19	39	3~ 400/690V	750	Y/Δ	250	100	●	●	✓
GMN8 140-300A/A	26,7	53,5	3~ 400/690V	750	Y/Δ	300	140	●	●	✓

P₂ Rated power output

I_N Rated current

● Standard

✓ ATEX Eex Version on demand

Characteristic curves

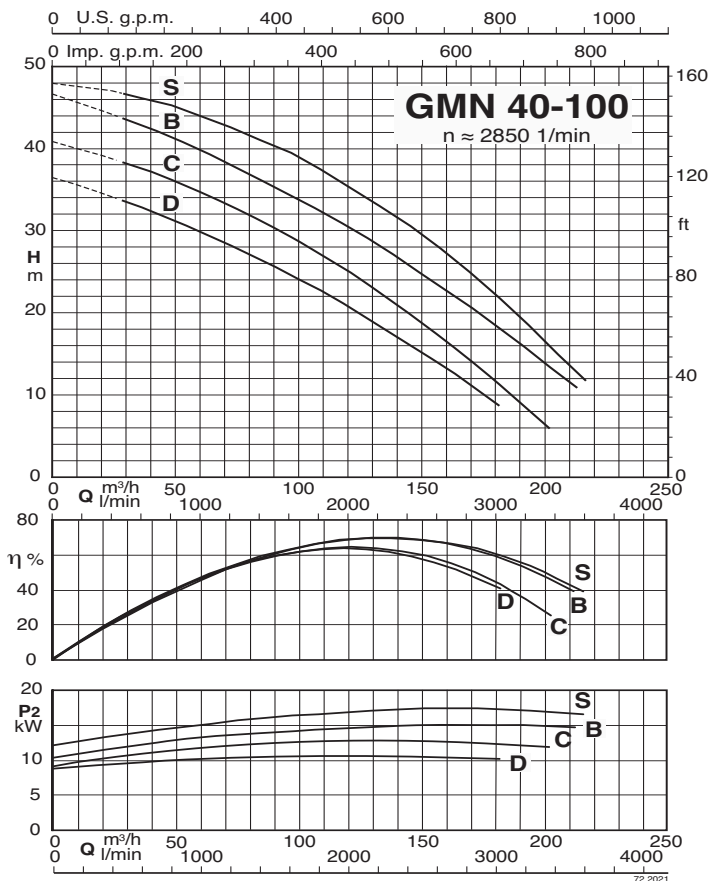
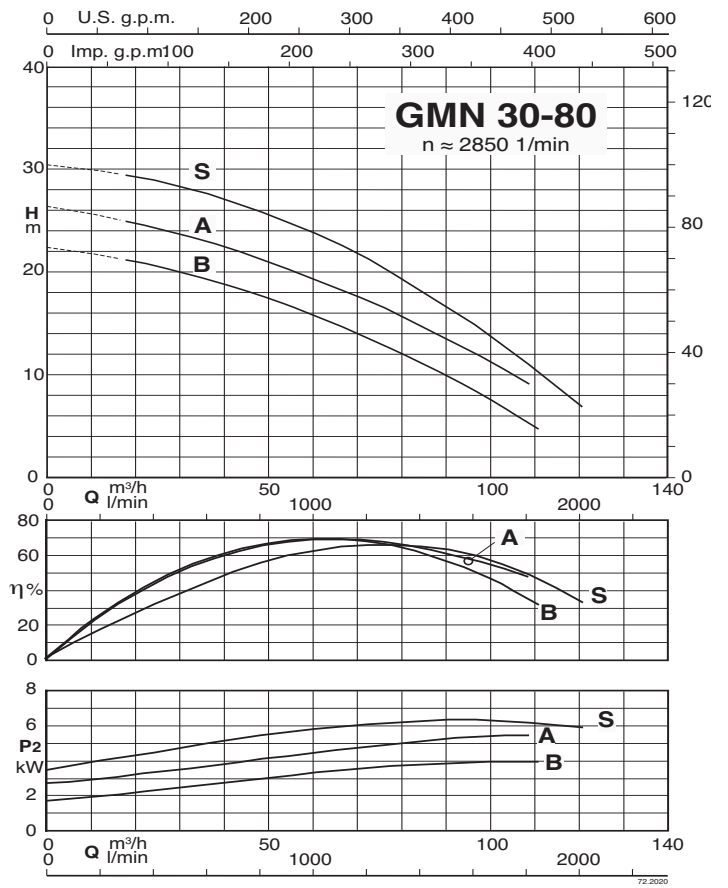
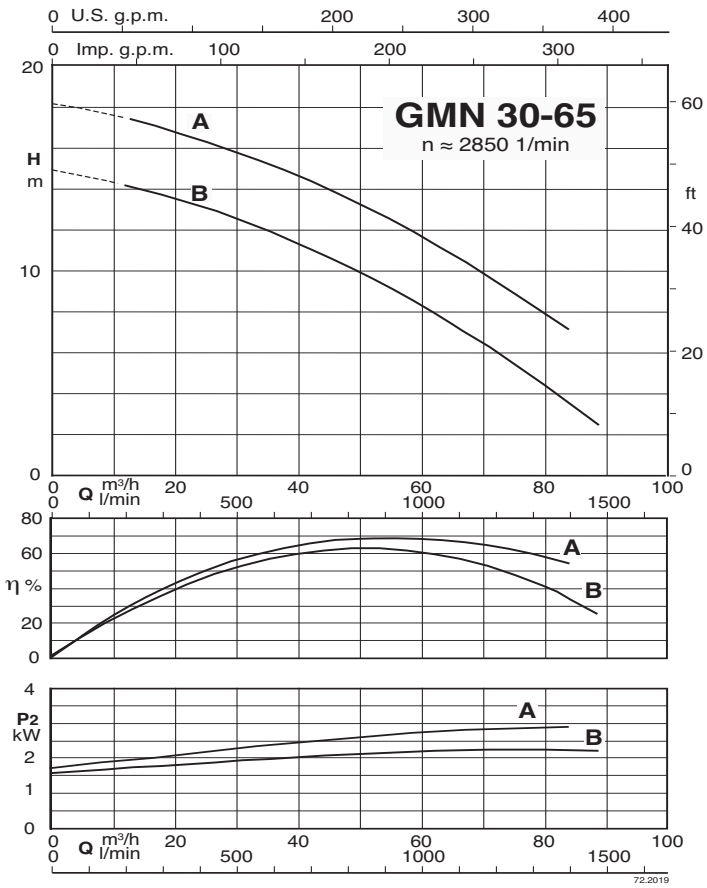

Characteristic curves

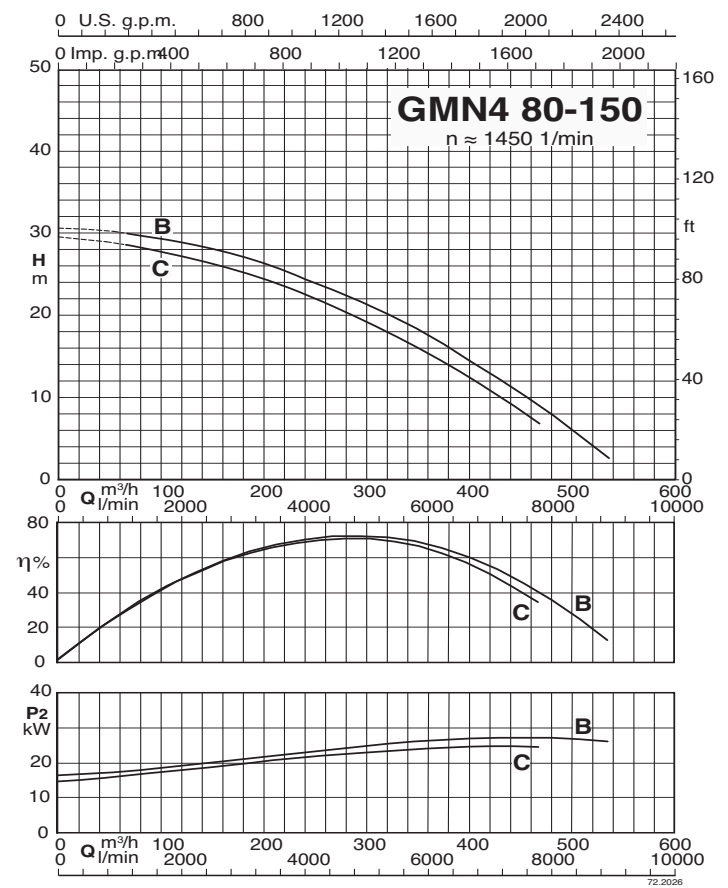
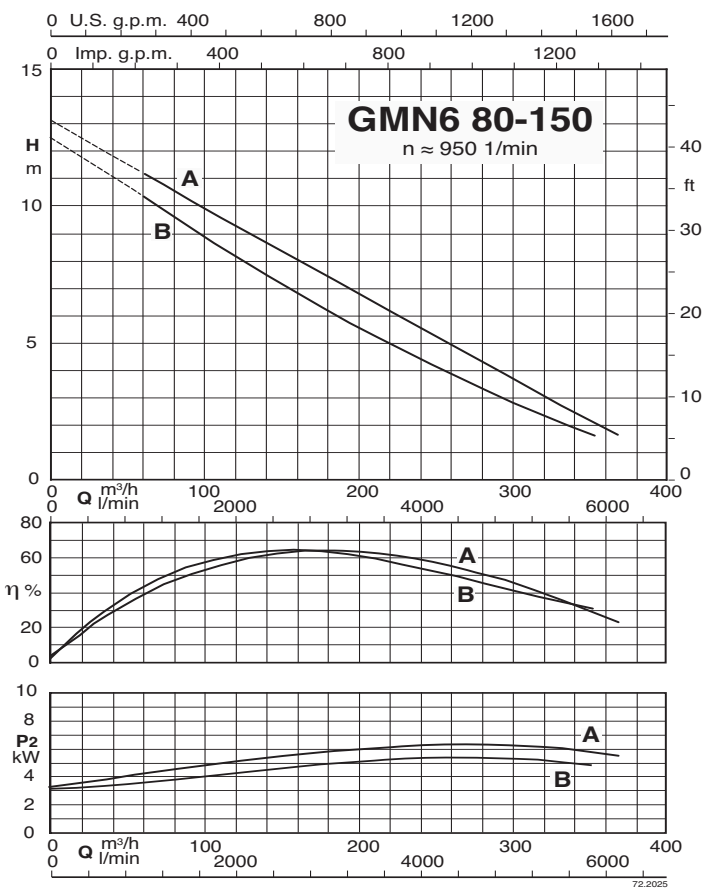
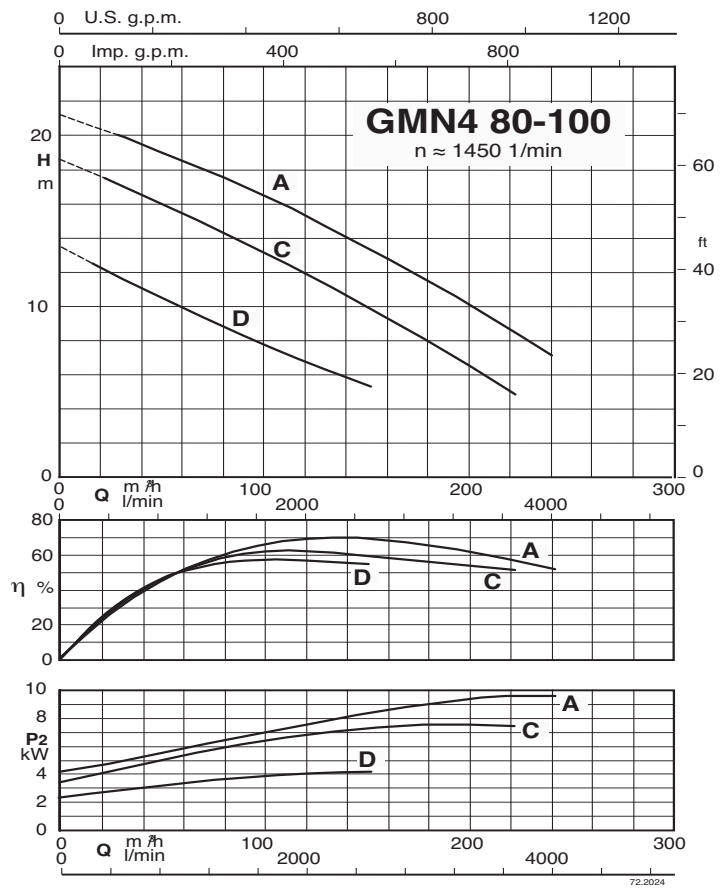
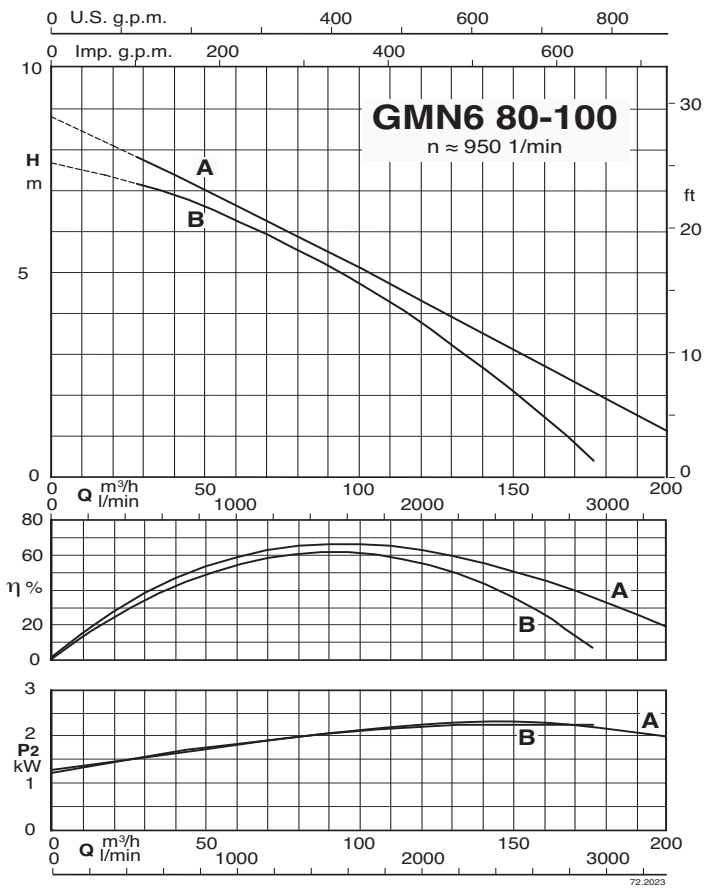

Characteristic curves

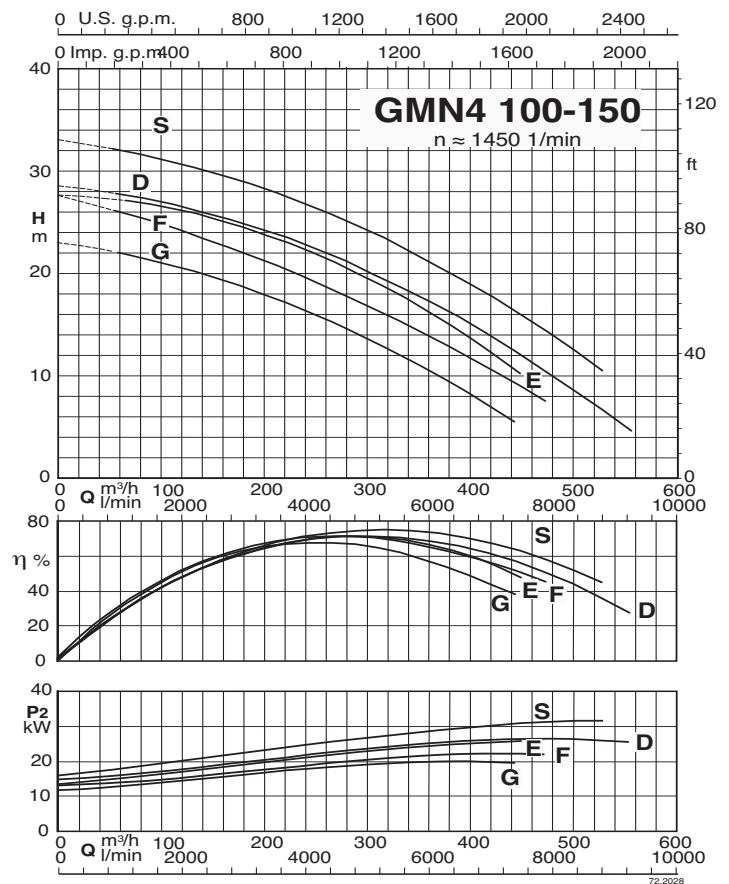
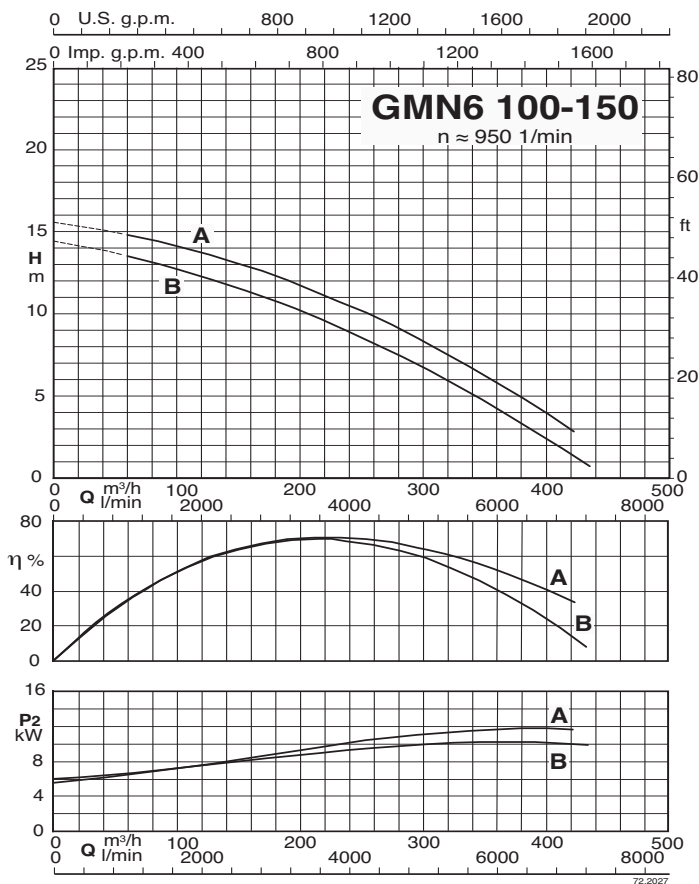

Characteristic curves

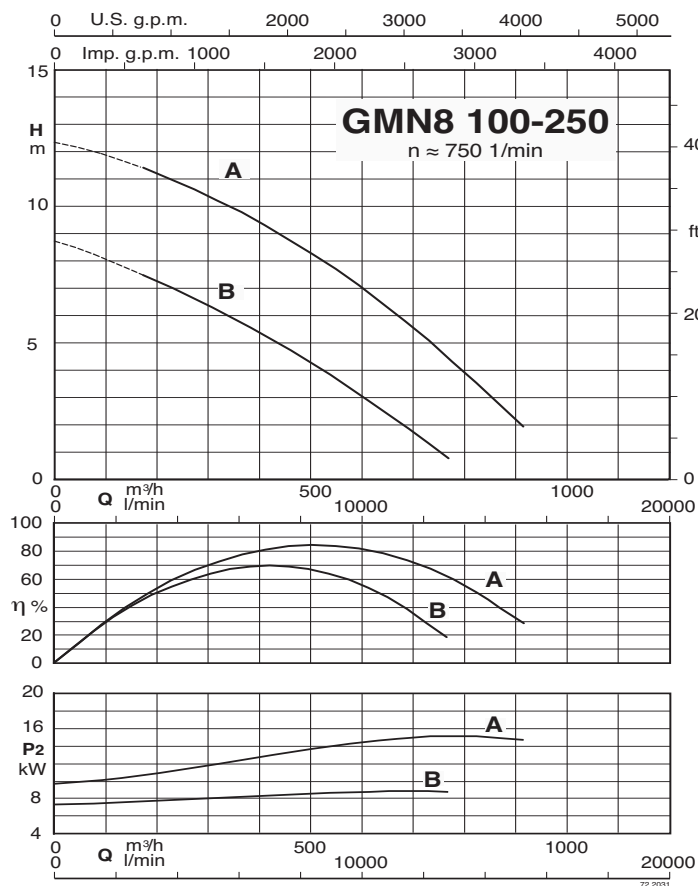
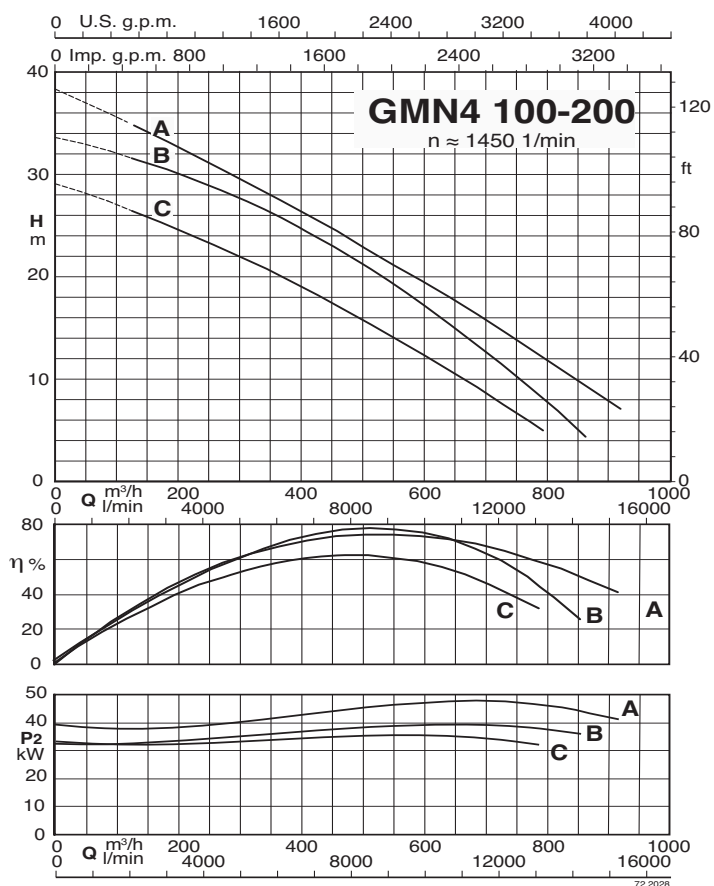
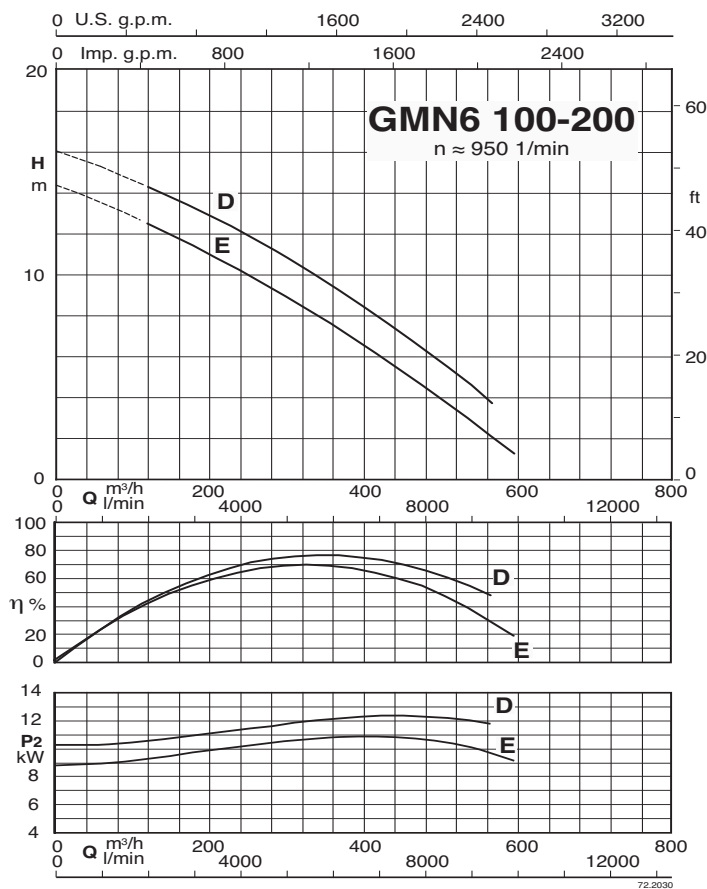
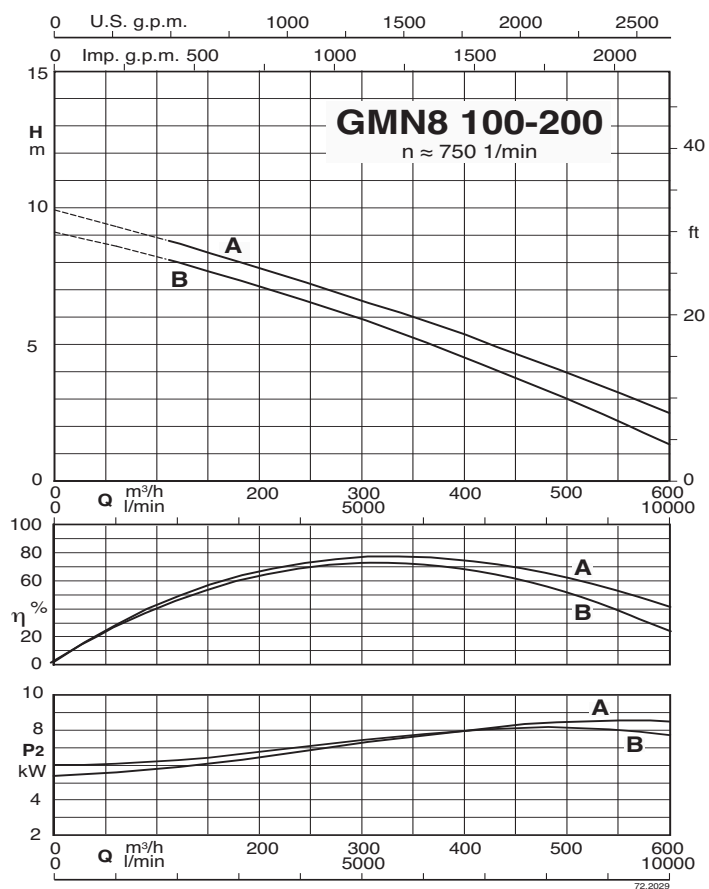

Characteristic curves

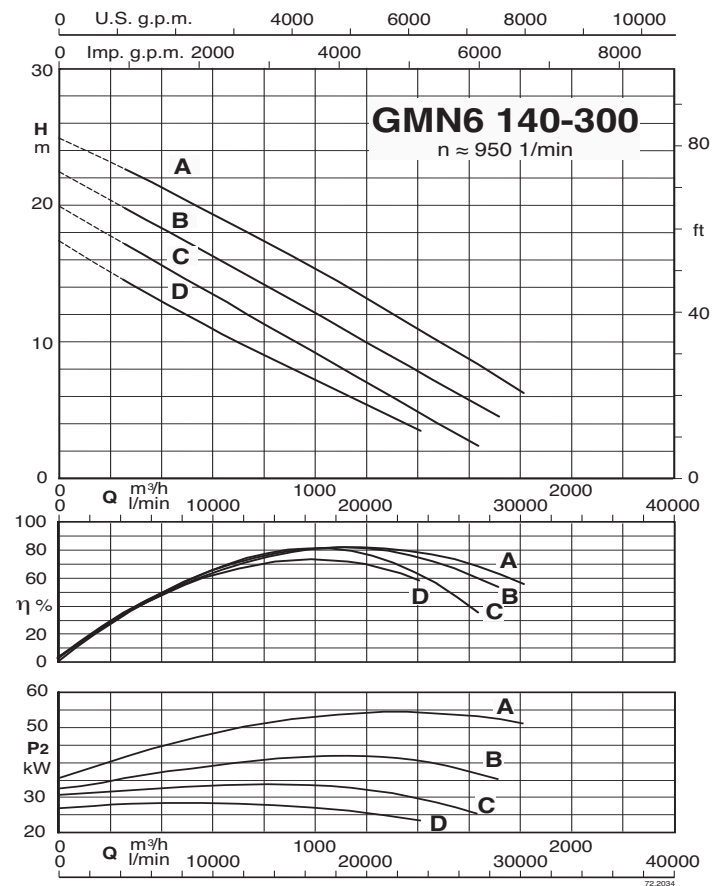
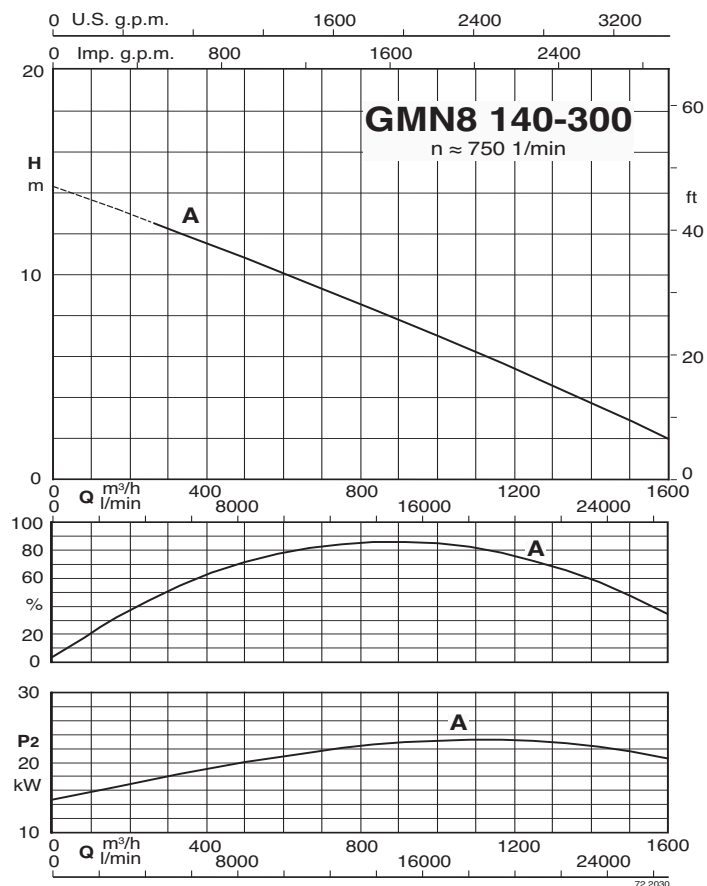
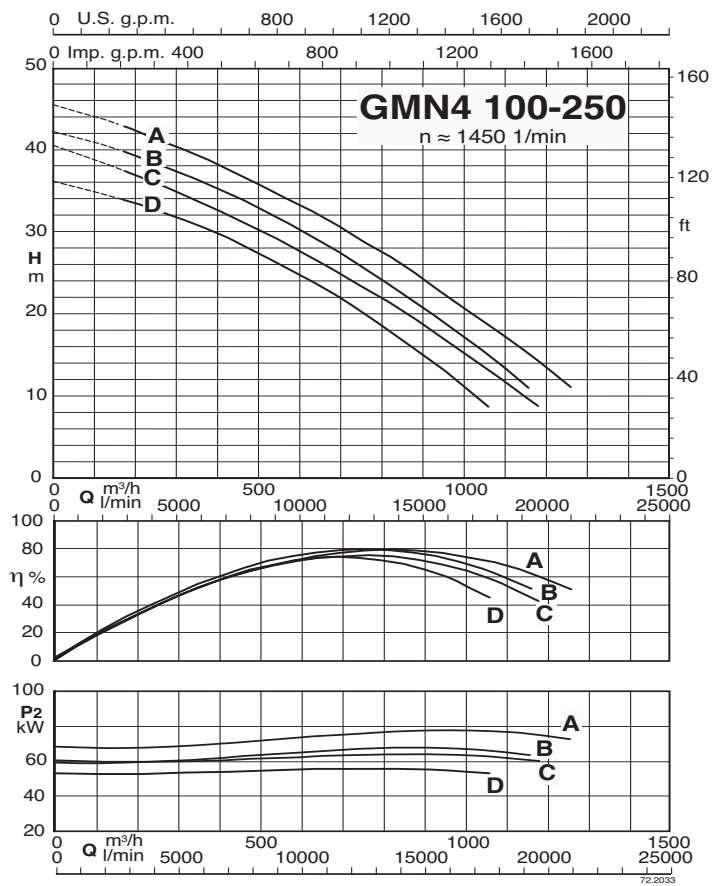
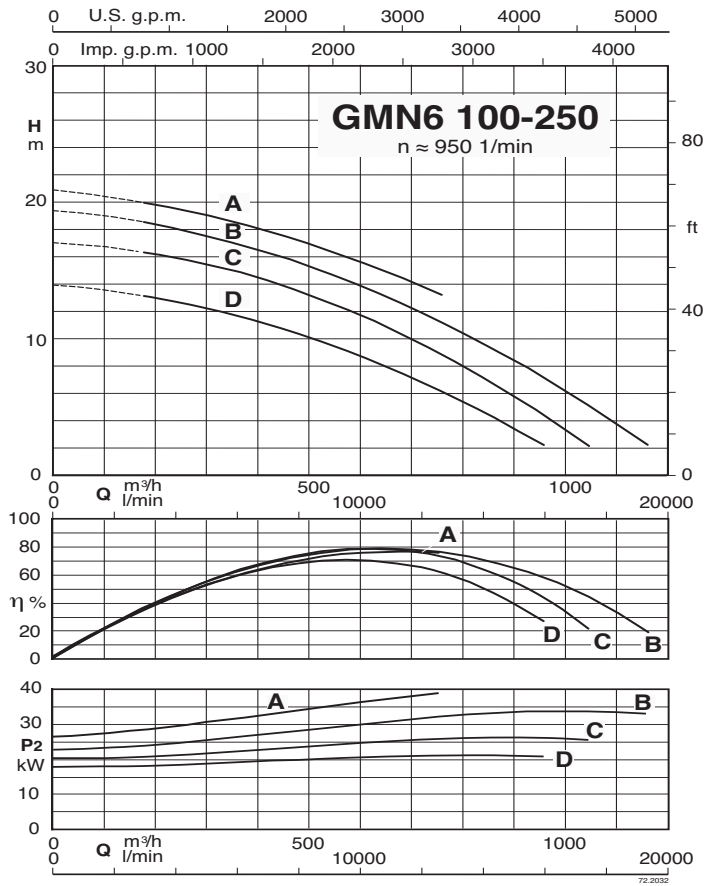

Dimensions and weights

GMN 30-65

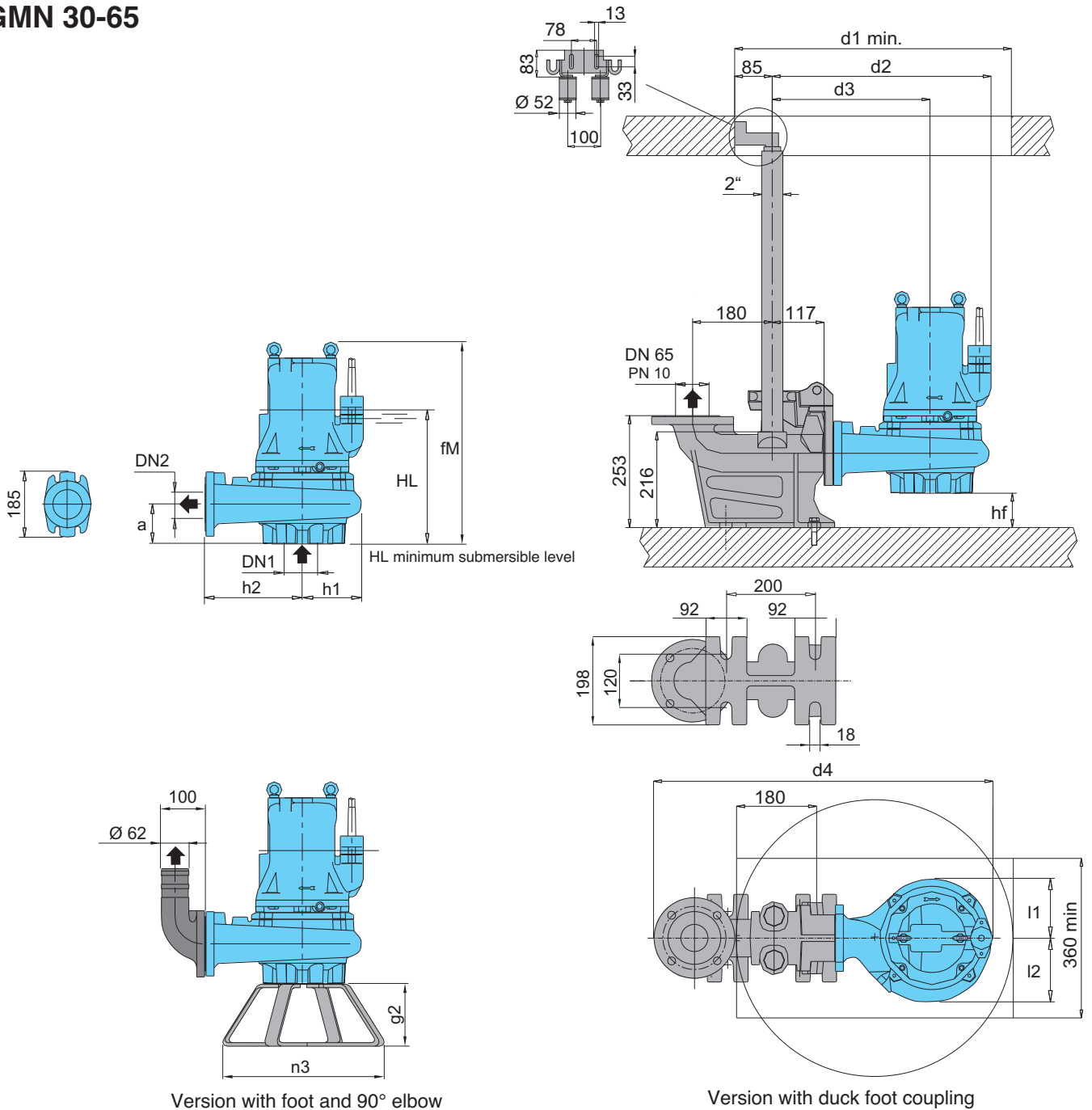

TYPE	EN 1092-2 PN 10		Dimensions mm														Weight kg
	DN1	DN2	fM	HL	hf	a	l1	l2	d1	d2	d3	d4	h1	h2	n3	g2	
GMN 30-65B/A	80	65	456	300	78	90	133	145	625	495	357	767	138	220	364	140	62
GMN 30-65A/A																	

Dimensions and weights

GMN 30-80

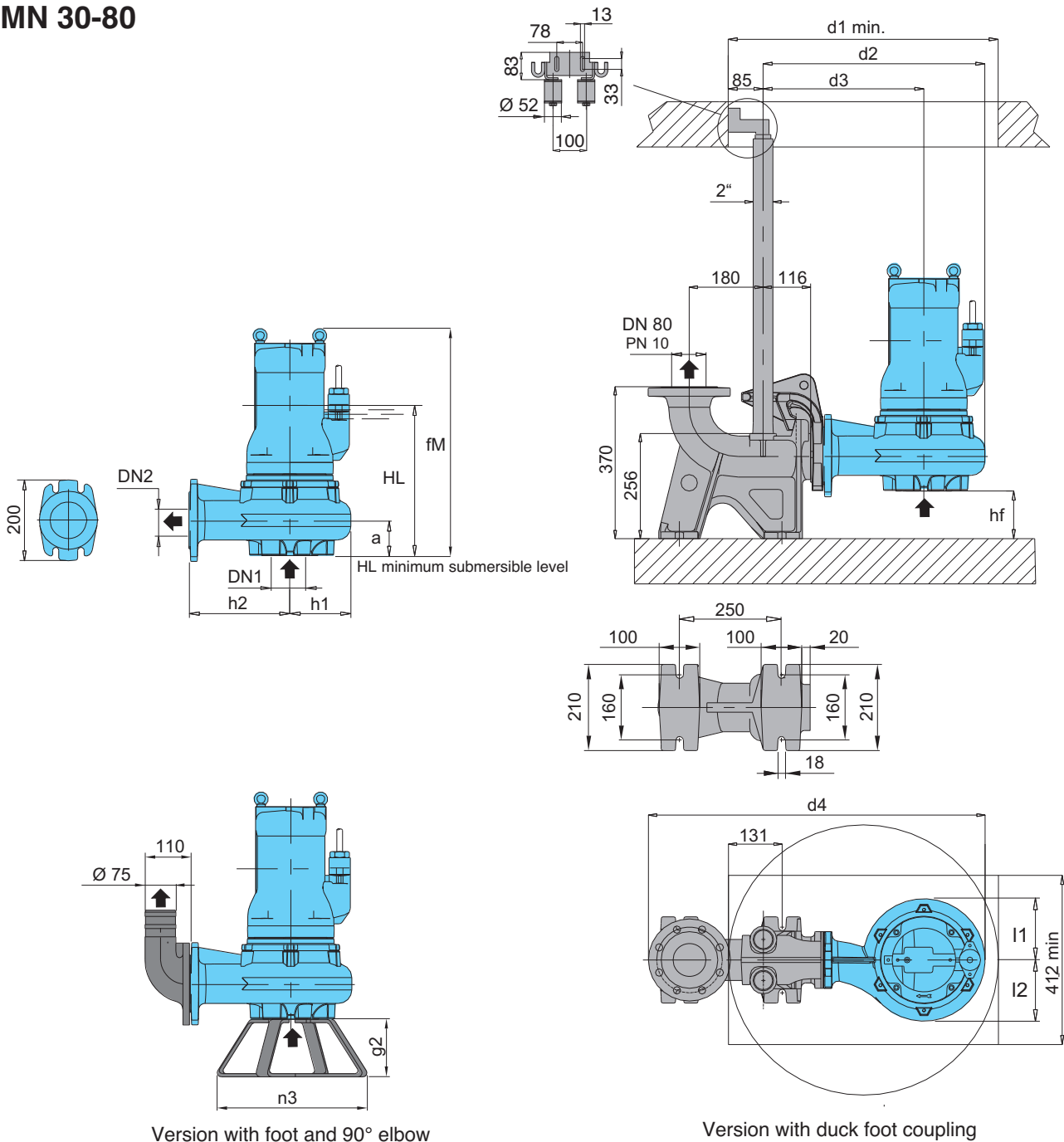

TYPE	EN 1092-2 PN 10		Dimensions mm														Weight kg
	DN1	DN2	fM	HL	hf	a	l1	l2	d1	d2	d3	d4	h1	h2	n3	g2	
GMN 30-80B/A	80	80	515	330	110	90	133	145	700	511	366	791	145	220	370	140	75
GMN 30-80A/A	80	80	515	330	110	90	133	145	700	511	366	791	145	220	370	140	75
GMN 30-80S/A	100	80	767	438	132	68	165	165	700	571	386	851	185	220	500	150	150

Dimensions and weights

GMN 40-100
GMN 50-100
GMN4 80-100
GMN6 80-100

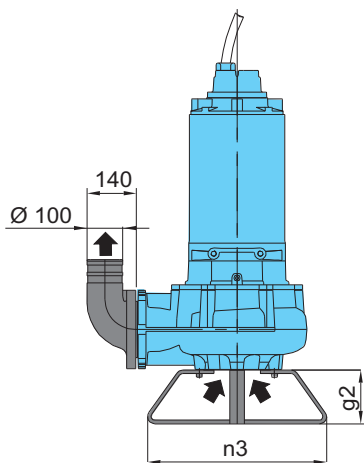
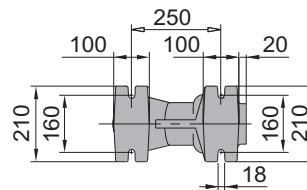
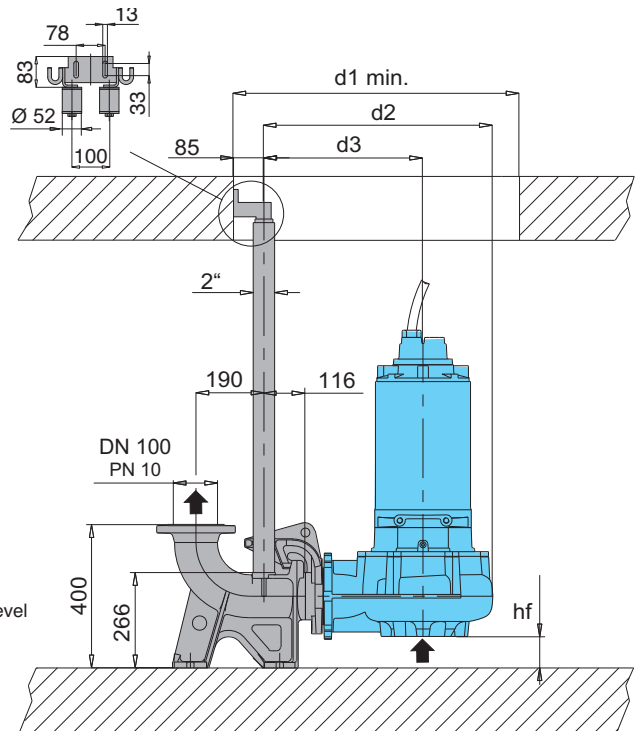
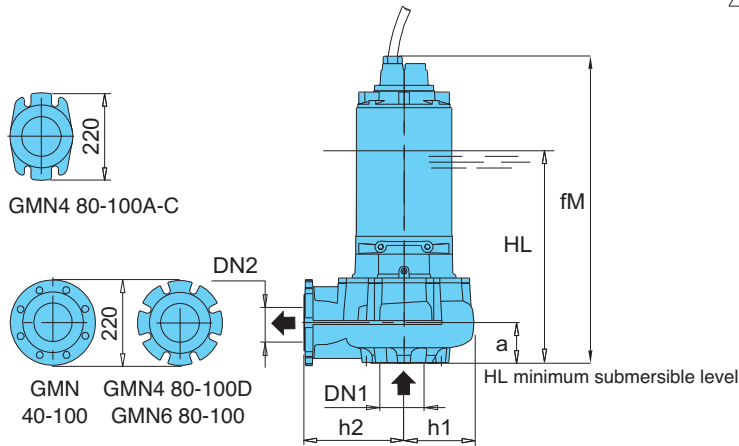

Version with foot and 90° elbow

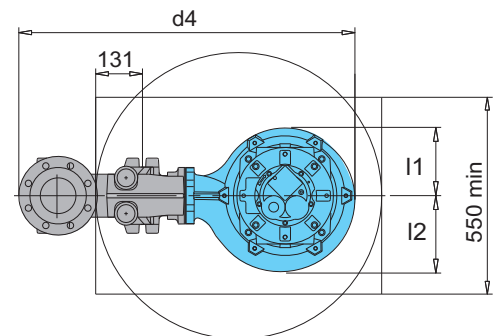

Version with duck foot coupling

TYPE	EN 1092-2 PN 10		Dimensions mm														Weight kg	
	DN1	DN2	fM	HL	hf	a	l1	l2	d1	d2	d3	d4	h1	h2	n3	g2		
GMN 40-100D/A	125	100	794	480	127	73	168	184	750	628	441	928	187	275	500	150	206	
GMN 40-100C/A																		
GMN 40-100B/A																		
GMN 40-100S/A	125	100	1269	570	127	73	193	193	800	628	441	928	187	275	500	150	340	
GMN4 80-100D/A	125	100	597	424	62	138	180	231	850	673	466	973	207	300	500	150	115	
GMN4 80-100C/A	125	100	852	526	54	147	189	212	800	640	445	940	195	279	500	150	175	
GMN4 80-100A/A	125	100	920	570	54	147	189	212	800	640	445	940	195	279	500	150	205	
GMN6 80-100B/A	125	100	531	372	62	138	180	231	850	673	466	973	207	300	500	150	96	
GMN6 80-100A/A			597	424													114	

Dimensions and weights

GMN6 80-150
GMN6 100-150
GMN4 80-150
GMN4 100-150

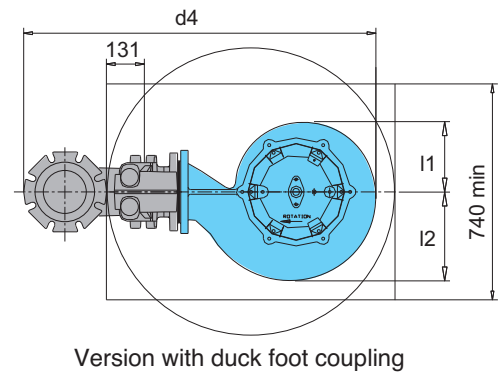
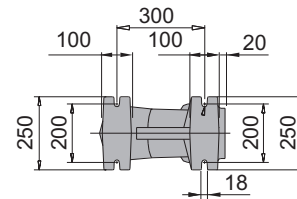
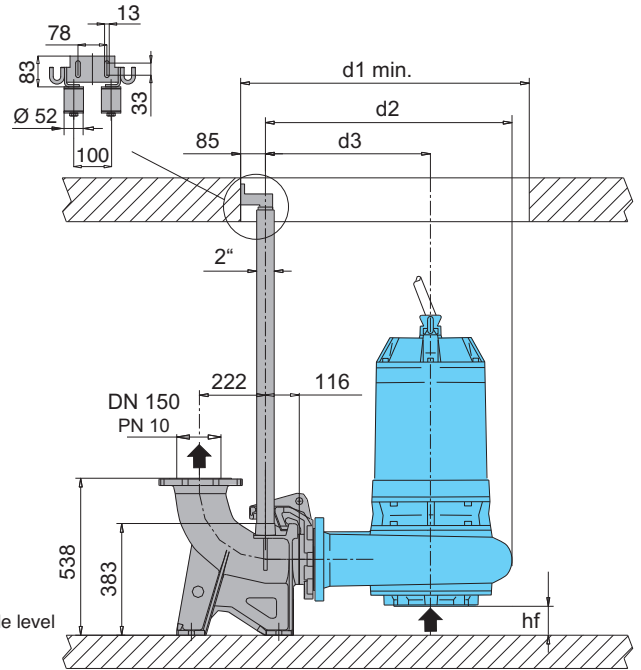
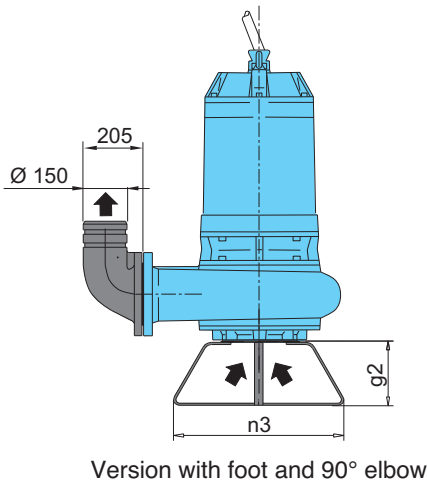
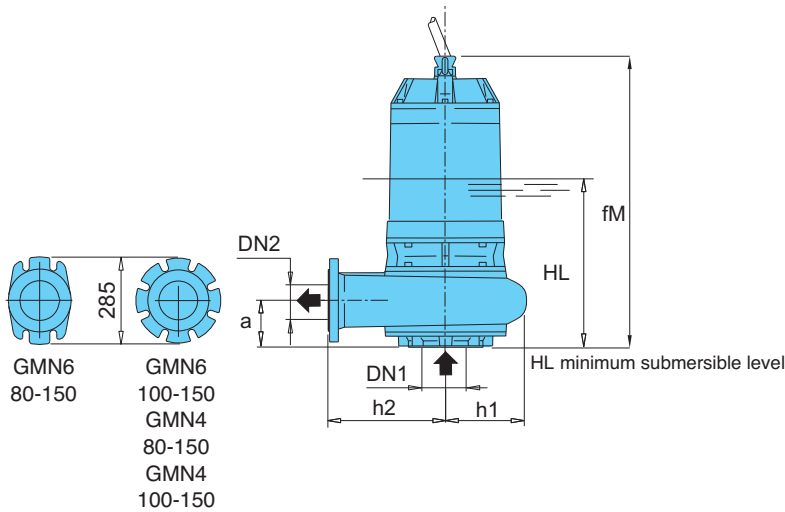

TYPE	EN 1092-2 PN 10		Dimensions mm														Weight kg
	DN1	DN2	fM	HL	hf	a	l1	l2	d1	d2	d3	d4	h1	h2	n3	g2	
GMN6 80-150B/A	150	150	820	540	113	147	191	223	850	673	467	1038	206	301	600	225	190
GMN6 80-150A/A			933	580													
GMN6 100-150B/B	150	150	1274	737	80	180	239	304	990	840	566	1208	273	400	500	225	382
GMN6 100-150A/B																	
GMN4 80-150C/B	150	150	1409	737	80	180	239	304	990	840	566	1208	273	400	500	225	450
GMN4 80-150B/B			1439	742													
GMN4 100-150G/A	150	150	1409	737	80	180	239	304	990	840	566	1208	273	400	500	225	430
GMN4 100-150F/A																	
GMN4 100-150E/B																	
GMN4 100-150D/B																	
GMN4 100-150S/B																	

Dimensions and weights

GMN4 100-200
GMN6 100-200
GMN8 100-200

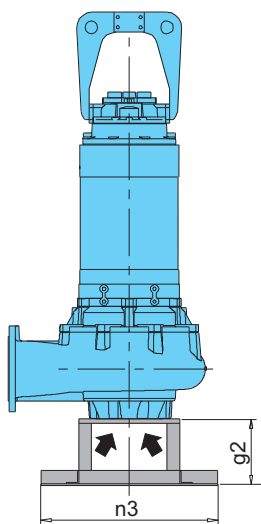
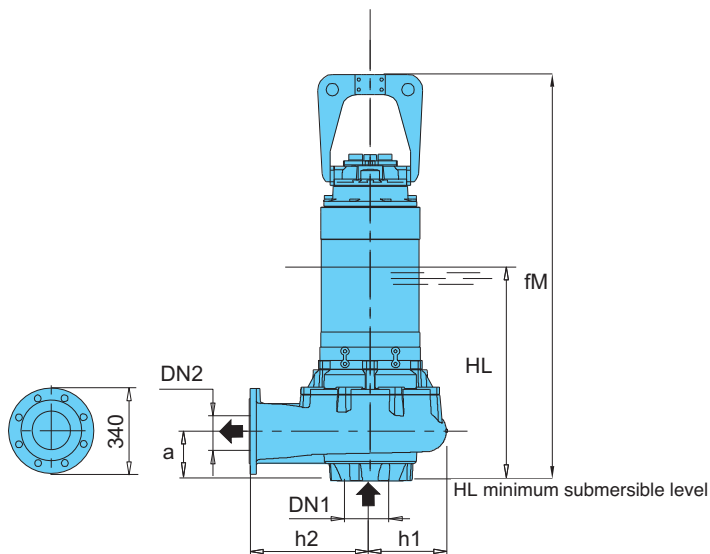

Version with foot

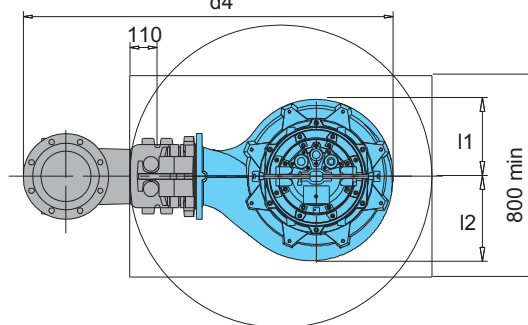
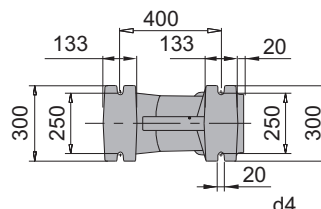
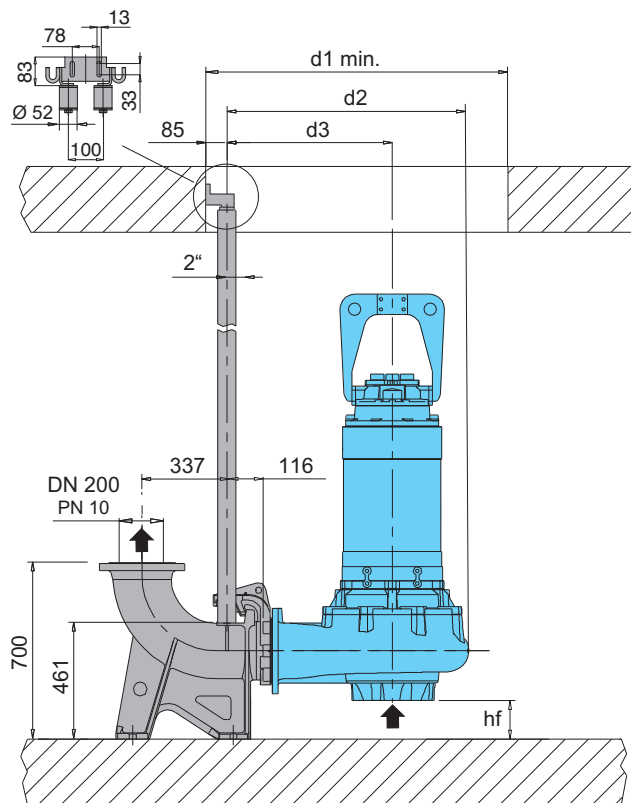

Version with duck foot coupling

TYPE	EN 1092-2 PN 10		Dimensions mm														Weight kg
	DN1	DN2	fM	HL	hf	a	l1	l2	d1	d2	d3	d4	h1	h2	n3	g2	
GMN4 100-200C/A																	
GMN4 100-200B/A	200	200	1613	780	153	198	306	335	1200	962	656	1469	306	480	700	265	665
GMN4 100-200A/A																	
GMN6 100-200E/B																	
GMN6 100-200D/B	200	200	1256	665	153	180	269	336	1200	958	656	1467	303	480	700	265	385
GMN8 100-200B/C																	
GMN8 100-200A/A	200	200	1392	665	153	180	269	335	1200	958	656	1467	303	480	700	265	435

Dimensions and weights

GMN4 100-250
GMN6 100-250
GMN8 100-250

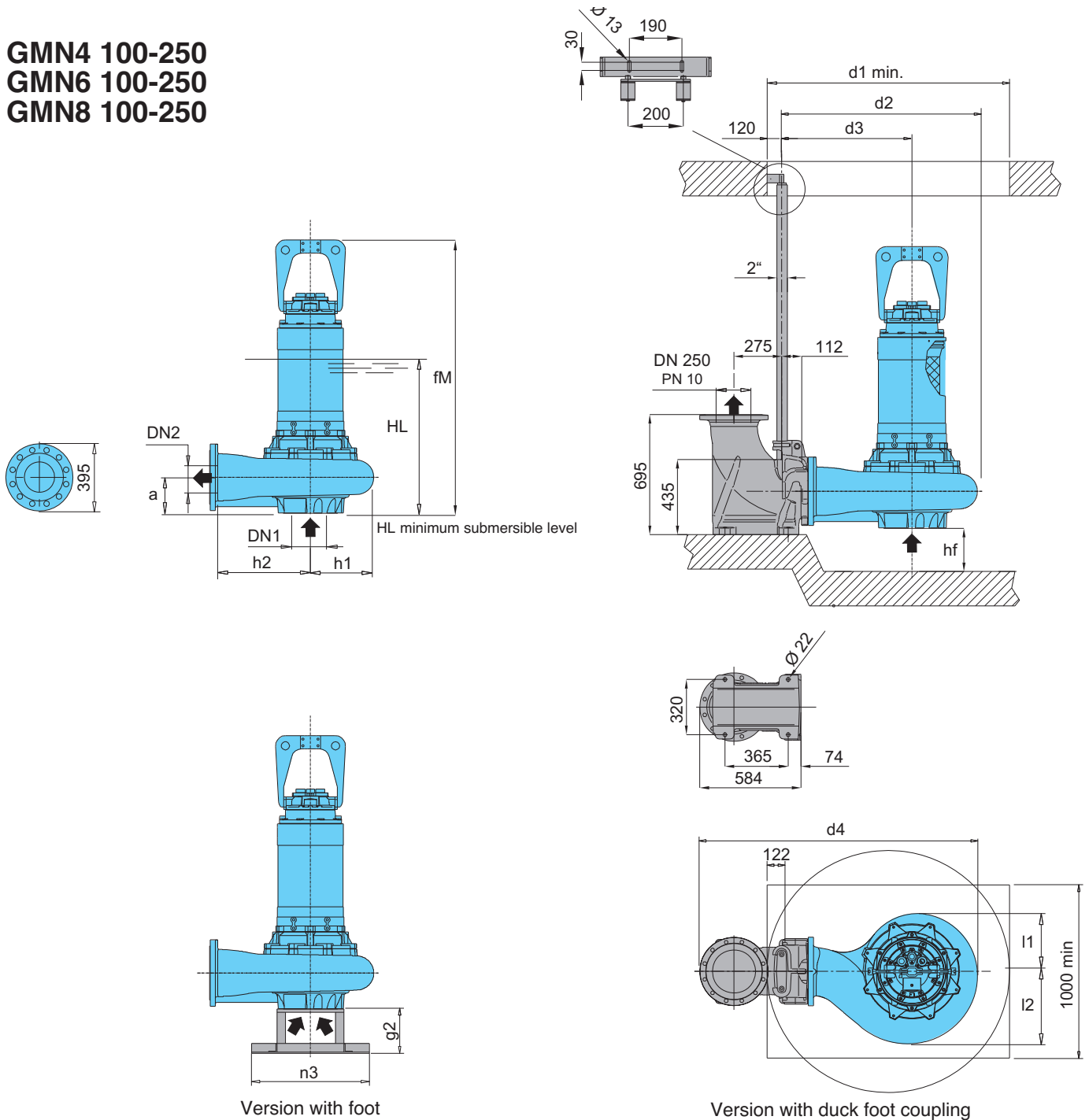

TYPE	EN 1092-2 PN 10		Dimensions mm														Weight kg																	
	DN1	DN2	fM	HL	hf	a	l1	l2	d1	d2	d3	d4	h1	h2	n3	g2																		
GMN4 100-250D	250	250	1710	797	250	214	336	419	1400	1130	752	1602	378	600	700	265	914																	
GMN4 100-250C																																		
GMN4 100-250B																																		
GMN4 100-250A																																		
GMN6 100-250D	250	250	1408	735	250	180	336	419	1400	1130	752	1602	378	600	700	265	530																	
GMN6 100-250C																		1437																
GMN6 100-250B																		250	250	1629	800	286	214	336	419	1400	1130	752	1602	378	600	700	265	750
GMN6 100-250A																																		
GMN8 100-250B/A	250	250	1408	735	250	180	336	419	1400	1130	752	1602	378	600	700	265	520																	
GMN8 100-250A/B																		1437	600															

Dimensions and weights

GMN6 140-300

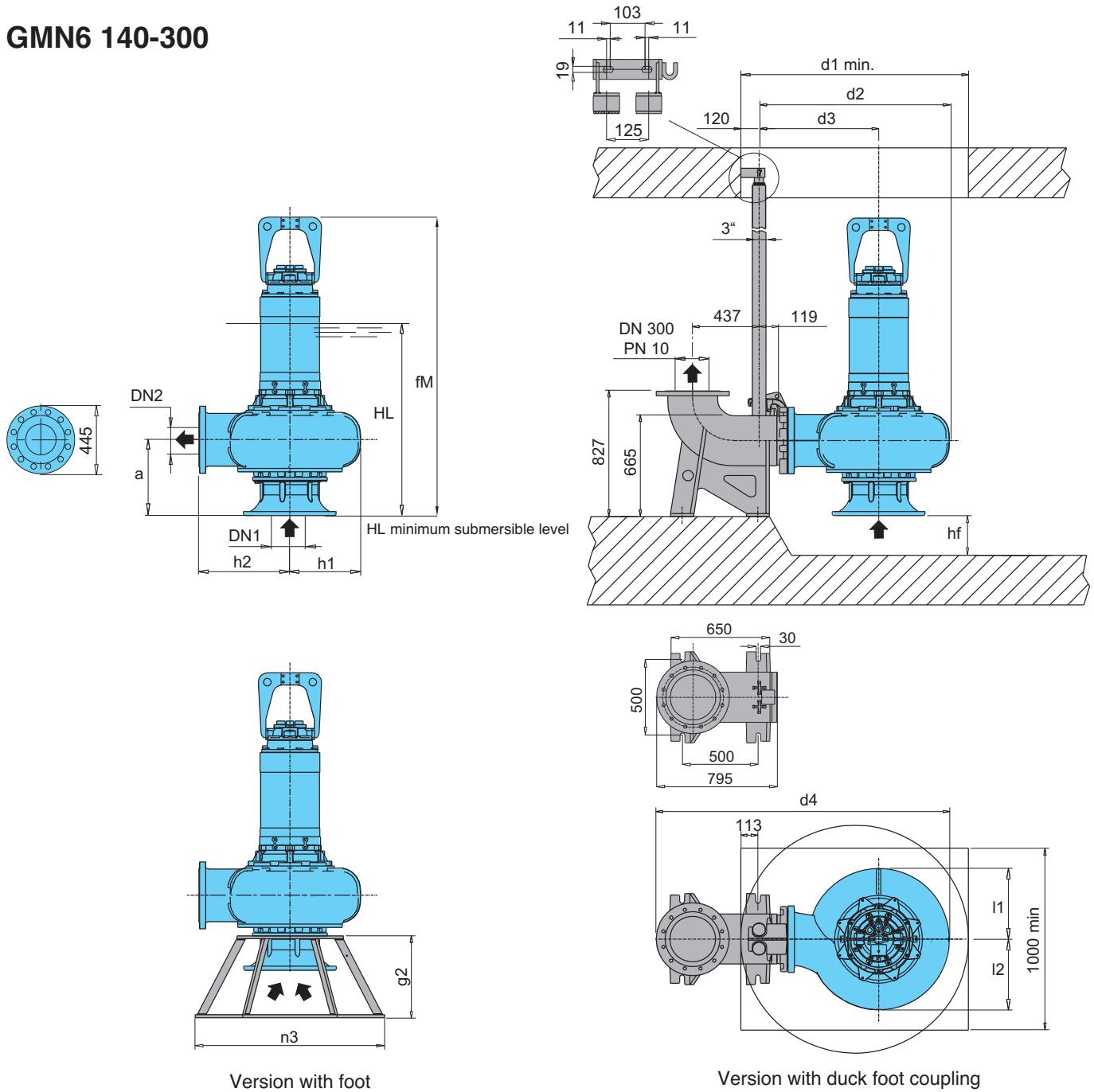

TYPE	EN 1092-2 PN 10		Dimensions mm														Weight kg
	DN1	DN2	fM	HL	hf	a	l1	l2	d1	d2	d3	d4	h1	h2	n3	g2	
GMN6 140-300D	350	300	1959	1127	260	494	465	465	1500	1254	789	1930	465	600	1248	540	1030
GMN6 140-300C																	
GMN6 140-300B	350	300	2040	1164	260	494	465	465	1500	1254	789	1930	465	600	1248	540	1190
GMN6 140-300A																	
GMN8 140-300A	350	300	1959	1127	260	494	465	465	1500	1254	789	1930	465	600	1248	540	1024



Construction

Submersible pumps with high power grinder.
Twin mechanical seal with oil chamber (lip-seal motor side up to 1,6 kW).
Delivery connection DN 40.

Applications

Suitable for pumping waste water containing long filamentous, Paper and textile materials and organics.
They are particularly suitable for use in domestic, residential and industrial installations
Solid passage from 6 and 7 mm

Operating conditions

Liquid temperature up to 40 °C.
Maximum immersion depth: 20 m (with suitable cable length).
Continuous duty (with pump immersed at minimum level).

Motor

2 poles induction, 50Hz
Single-phase version: 230V ± 10%, with float switch and control box with thermal protection and starting capacitors.
Three-phase version: 400V ± 10%,
400/690V ± 10%

Insulation class: H
Protection degree: IP 68
N° of starting x hour: max 15 with regular intervals
Cable: H07RN-F, length 10 m
Other models: contact our sale office
Classification scheme IE3.

Main materials

- Pump casing: cast iron EN-GJL-250
- Motor casing: cast iron EN-GJL-250
- Motor cover: cast iron EN-GJL-250
- Impeller: cast iron EN-GJS-400
- Shaft : stainless steel AISI 420B
- Lip seal made of nitrile up to 1,6 kW
- Mechanical seal motor side: graphite/ceramic over 1,6 kW
- Mechanical seal pump side: silicon carbide/silicon carbide

Coverage chart

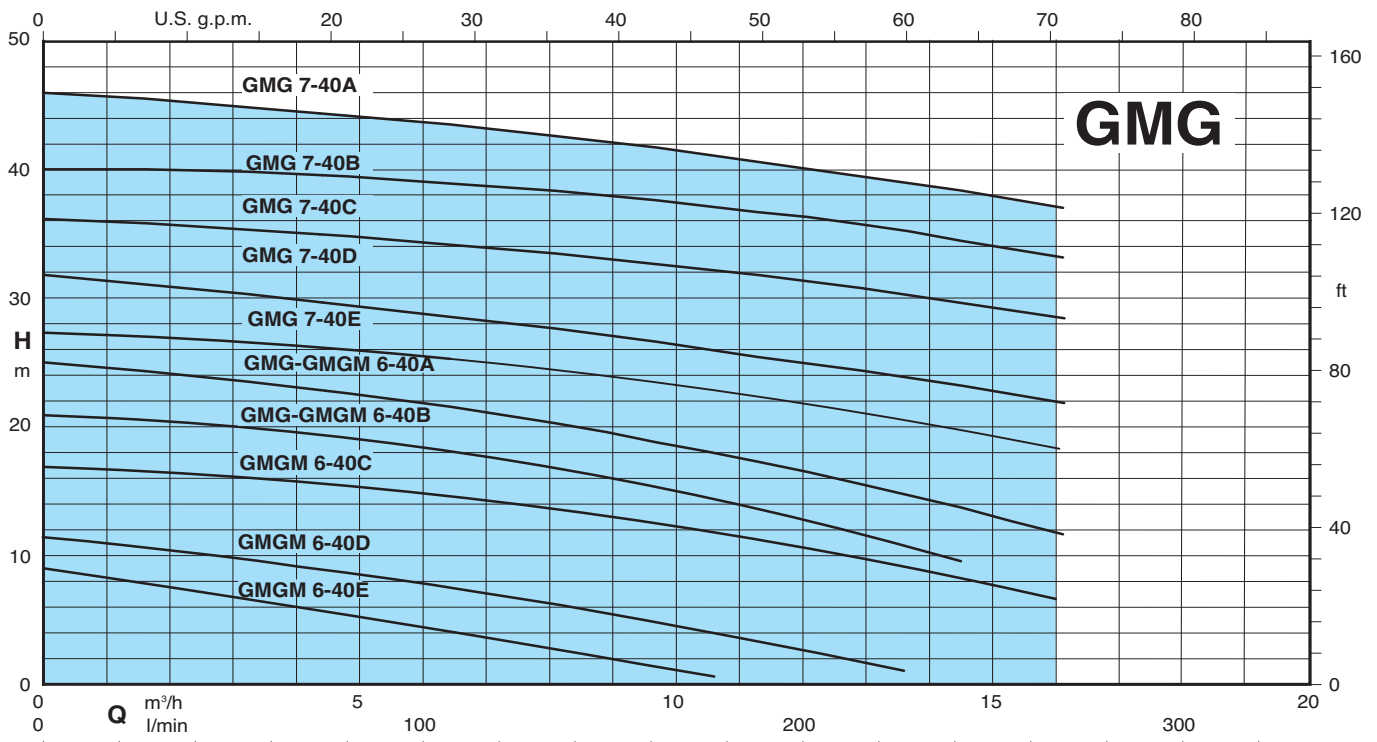

Technical data

TYPE	P ₂ kW	I _N A	Power Supply	r.p.m.	Starting	DN mm	Free passage Ø mm	Thermal protector	Humidity probe	 ATEX Eex
GMGM 6-40E/B	1,1	6,6	1~ 230V	2850	D.O.L.	40	6	●	NO	
GMGM 6-40D/B	1,1	6,6	1~ 230V	2850	D.O.L.	40	6	●	NO	
GMGM 6-40C/A	1,1	6,6	1~ 230V	2850	D.O.L.	40	6	●	NO	
GMGM 6-40B/A	1,5	9	1~ 230V	2850	D.O.L.	40	6	●	NO	
GMG 6-40B/A	1,6	3,1	3~ 400V	2850	D.O.L.	40	6	NO	NO	✓
GMGM 6-40A/A	1,9	11,4	1~ 230V	2850	D.O.L.	40	6	●	NO	
GMG 6-40A/A	2,4	4,5	3~ 400V	2850	D.O.L.	40	6	NO	NO	✓
GMG 7-40E/A	3,1	5,8	3~ 400V	2850	D.O.L.	40	7	NO	NO	✓
GMG 7-40D/A	3,1	5,8	3~ 400V	2850	D.O.L.	40	7	NO	NO	✓
GMG 7-40C/A	4,2	7,7	3~ 400/690V	2850	Y/Δ	40	7	●	●	✓
GMG 7-40B/A	5	9,1	3~ 400/690V	2850	Y/Δ	40	7	●	●	✓
GMG 7-40A/A	5	9,1	3~ 400/690V	2850	Y/Δ	40	7	●	●	✓

P₂ Rated power output

I_N Rated current

● Standard

✓ ATEX Eex Version on demand

Characteristic curves

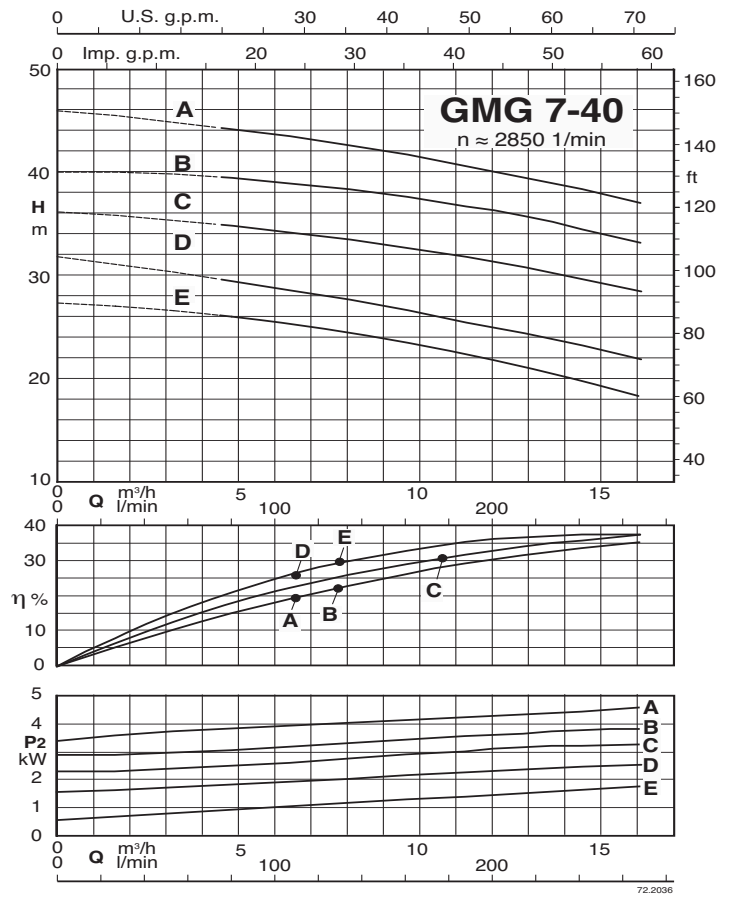
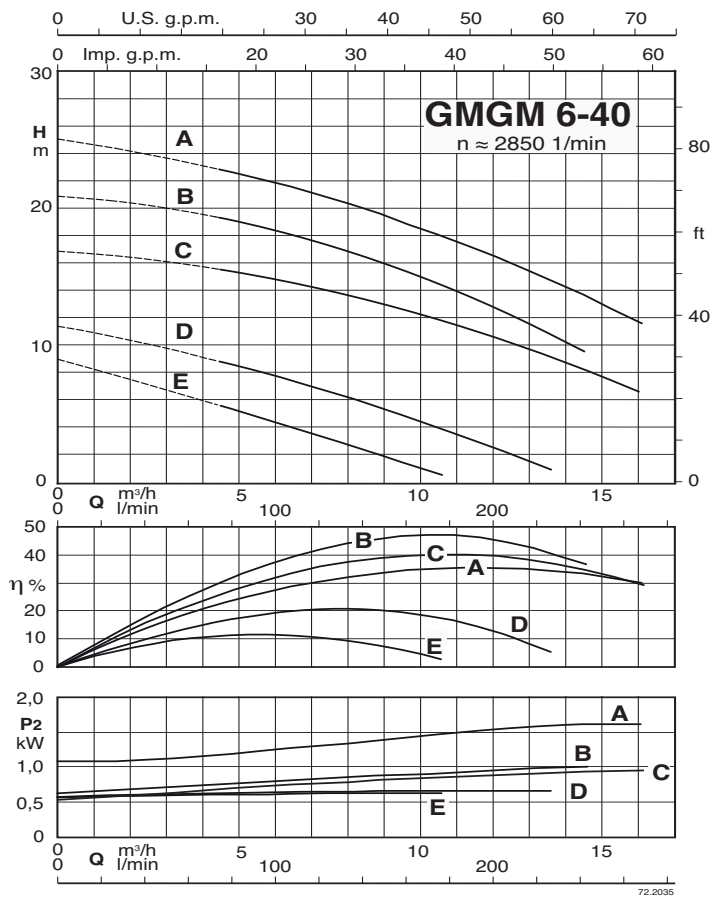

Dimensions and weights

GMGM 6-40
GMG 6-40
GMG 7-40

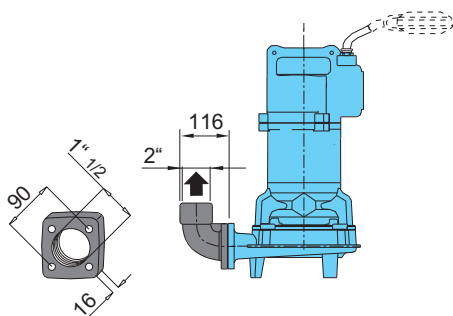
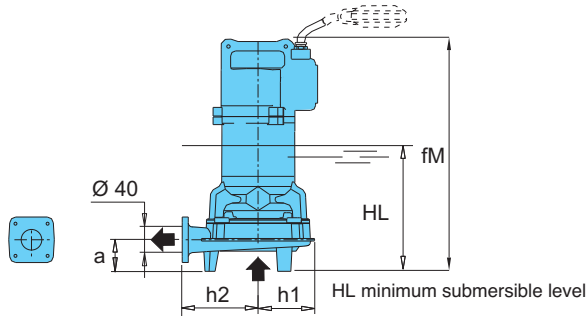

Version with threaded flange and 90° elbow

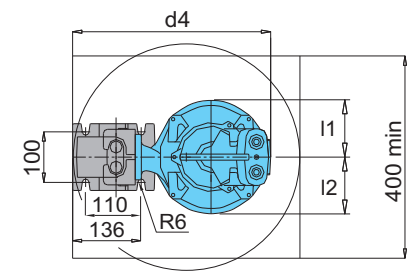
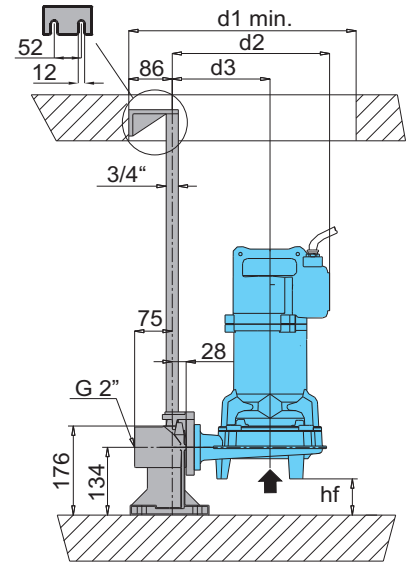

Version with duck foot coupling

TYPE	Dimensions mm												Weight kg	
	Ø1	fM	HL	hf	a	l1	l2	d1	d2	d3	d4	h1		h2
GMGM 6-40E/B	40	487	246	65	103	122	122	450	297	178	392	118	135	30
GMGM 6-40D/B														
GMGM 6-40C/A														
GMGM 6-40B/A														
GMG 6-40A/A	40	464	316	72	63	112	112	450	312	194	392	118	150	40
GMG 6-40B/A														
GMGM 6-40A/A														
GMG 6-40A/A														
GMG 7-40E/A	40	451	325	17	117	121	121	450	327	189	413	138	150	52
GMG 7-40D/A														
GMG 7-40C/A														
GMG 7-40B/A														
GMG 7-40A/A	40	510	353	17	117	121	121	450	334	189	420	147	150	67

Control box

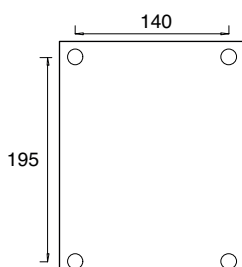

To fix the control panel, use the preposed holes as specify in this drawing. In order to maintain the protection degree, suitable fixing devices must be used.



Construction

Submersible pumps in **AISI 316** stainless steel.

I-GMV with free-flow (vortex) impeller

I-GMC with single-channel impeller

I-GMN with channels impeller

Twin mechanical seal with oil chamber (lip-seal motor side up to 2,4 kW 2 poles).

Delivery connection DN 50-65-80-100-150

Applications

Suitable to pump aggressive and corrosive liquids, particularly to drain waste water in industrial and chemical process plants. Solid passage from 30 to 100 mm

Operating conditions

Liquid temperature up to 40 °C.

Maximum immersion depth: 20 m (with suitable cable length).

Continuous duty (with pump immersed at minimum level).

Main materials

Pump casing: stainless steel AISI 316

Motor casing: stainless steel AISI 316

Motor cover: stainless steel AISI 316

Impeller: stainless steel AISI 316

Shaft: stainless steel AISI 316L

Screws: stainless steel AISI 316

Mechanical seal motor side: graphite/ceramic/FPM (lip-seal made of nitrile up to 2,4 kW 2 poles).

Mechanical seal pump side: silicon carbide/silicon carbide/FPM

Motor

2 or 4 poles induction, 50Hz

Three-phase version: 400V ± 10%,

400/690V ± 10%

Insulation class: H

Protection degree: IP 68

N° of starting x hour: max 15 with regular intervals

Cable: H07RN-F, length 10 m

Other models: contact our sale office

Classification scheme IE3.

Coverage chart

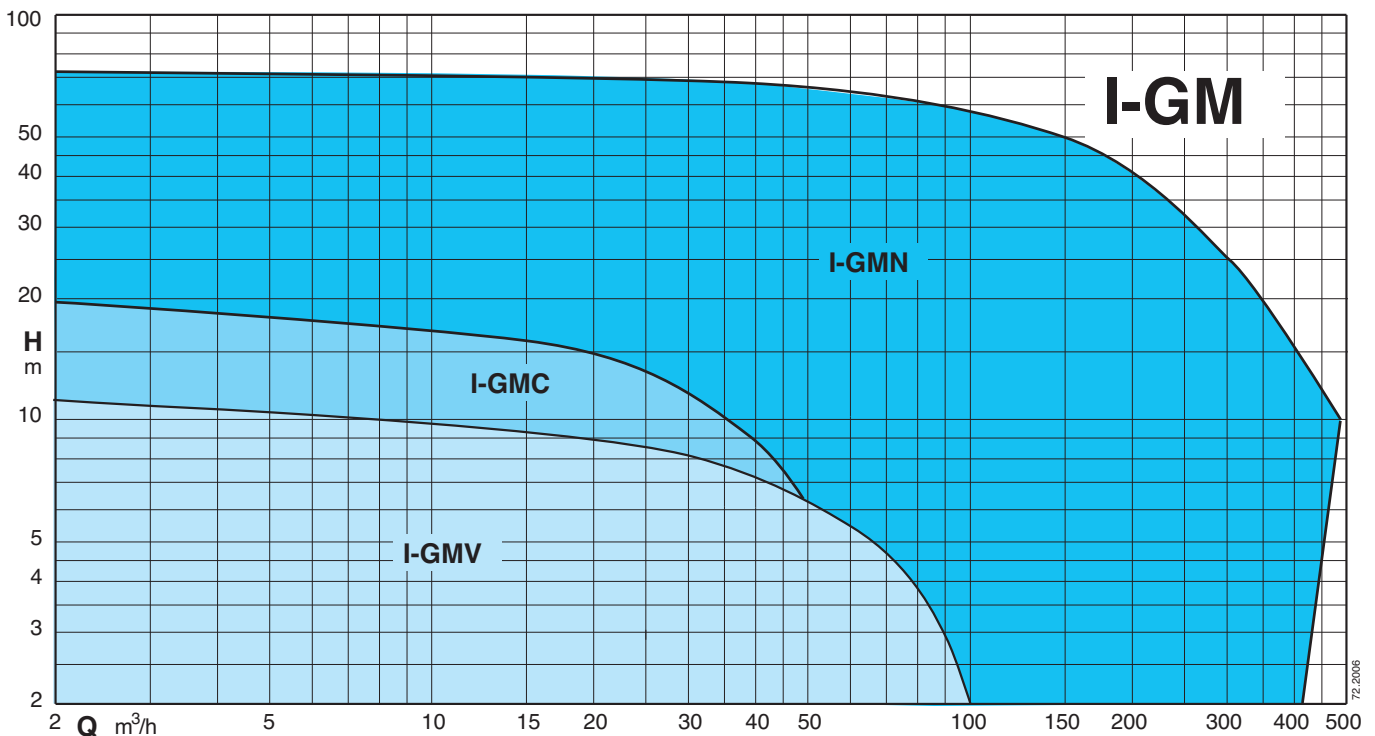

Technical data

TYPE	P ₂ kW	I _N A	Power Supply	r.p.m.	Starting	DN mm	Free passage Ø mm	Thermal protector	Humidity probe	 ATEX Eex
I-GMV 50-50C/A	1,8	3,5	3~ 400V	2850	D.O.L.	50	50	NO	NO	✓
I-GMV 50-50B/B	1,6	3,1	3~ 400V	2850	D.O.L.	50	50	NO	NO	✓
I-GMV 50-50A/B	2,4	4,5	3~ 400V	2850	D.O.L.	50	50	NO	NO	✓
I-GMV4 50-65C/A	1,1	2,4	3~ 400V	1450	D.O.L.	65	50	NO	NO	✓
I-GMV4 50-65B/A	1,4	2,7	3~ 400V	1450	D.O.L.	65	50	NO	NO	✓
I-GMV4 50-65A/A	1,6	3,1	3~ 400V	1450	D.O.L.	65	50	NO	NO	✓
I-GMV4 50-80B/A	2,3	4,4	3~ 400V	1450	D.O.L.	80	50	NO	NO	✓
I-GMV4 50-80A/A	2,8	5,4	3~ 400V	1450	D.O.L.	80	50	NO	NO	✓
I-GMC 40-65B/A	2,1	3,9	3~ 400V	2850	D.O.L.	65	40	NO	NO	✓
I-GMC 40-65A/A	2,8	6	3~ 400V	2850	D.O.L.	65	40	NO	NO	✓
I-GMN 30-65B/A	3,1	5,8	3~ 400V	2850	D.O.L.	65	30	NO	NO	✓
I-GMN 30-65A/A	3,6	6,6	3~ 400V	2850	D.O.L.	65	30	NO	NO	✓
I-GMN 30-80B/A	5	9,1	3~ 400/690V	2850	Y/Δ	80	30	●	●	✓
I-GMN 30-80A/A	6,5	11,8	3~ 400/690V	2850	Y/Δ	80	30	●	●	✓
I-GMN 30-80S/A	7,5	13,5	3~ 400/690V	2850	Y/Δ	80	30	●	●	✓
I-GMN 40-100D/A	12	21,7	3~ 400/690V	2850	Y/Δ	100	40	●	●	✓
I-GMN 40-100C/A	13,8	24,8	3~ 400/690V	2850	Y/Δ	100	40	●	●	✓
I-GMN 40-100B/A	16,6	29,8	3~ 400/690V	2850	Y/Δ	100	40	●	●	✓
I-GMN 40-100S/A	20	35,8	3~ 400/690V	2850	Y/Δ	100	40	●	●	✓
I-GMN4 60-100B/A	6	11,5	3~ 400/690V	1450	Y/Δ	100	60	●	●	✓
I-GMN4 60-100A/A	7,1	13,5	3~ 400/690V	1450	Y/Δ	100	60	●	●	✓
I-GMN4 80-100B/A	10	19	3~ 400/690V	1450	Y/Δ	100	80	●	●	✓
I-GMN4 80-100A/A	10	19	3~ 400/690V	1450	Y/Δ	100	80	●	●	✓
I-GMN4 100-150B/A	23,6	43,3	3~ 400/690V	1450	Y/Δ	150	100	●	●	✓
I-GMN4 100-150A/A	30	54,3	3~ 400/690V	1450	Y/Δ	150	100	●	●	✓

P₂ Rated power outputI_N Rated current

● Standard

✓ ATEX Eex Version on demand

Characteristic curves

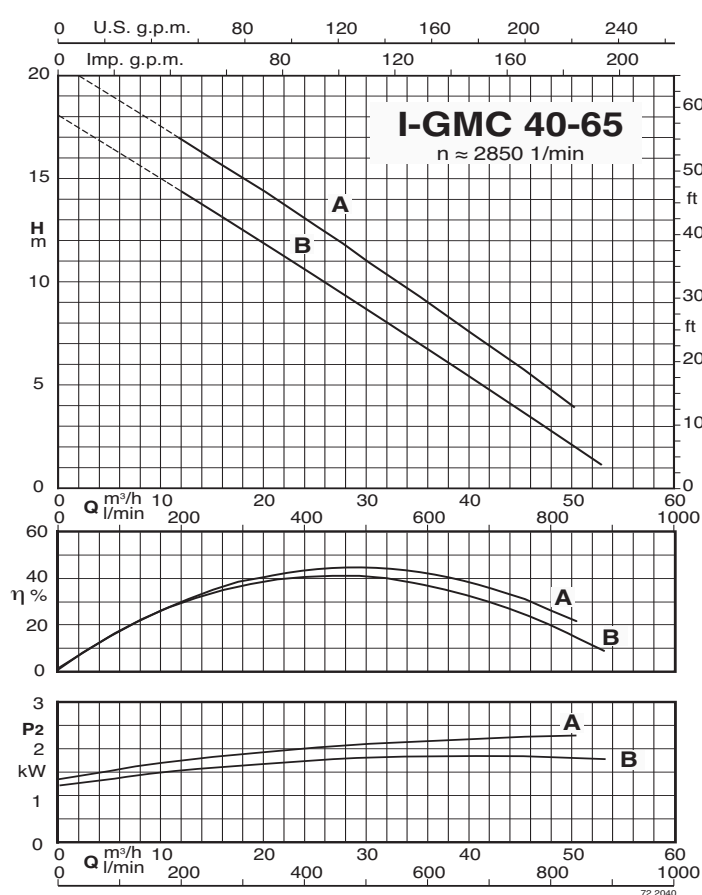
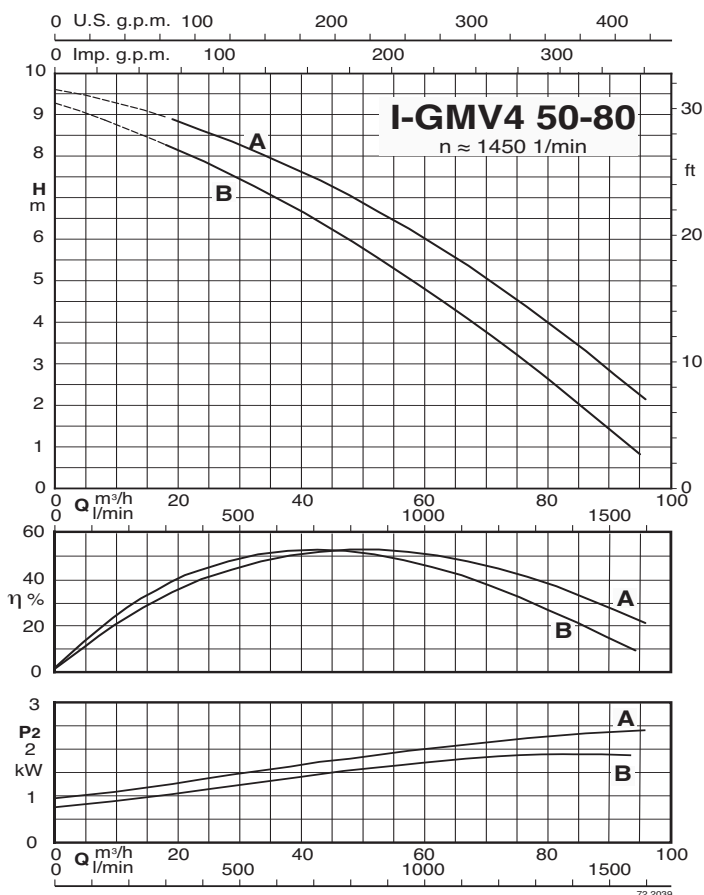
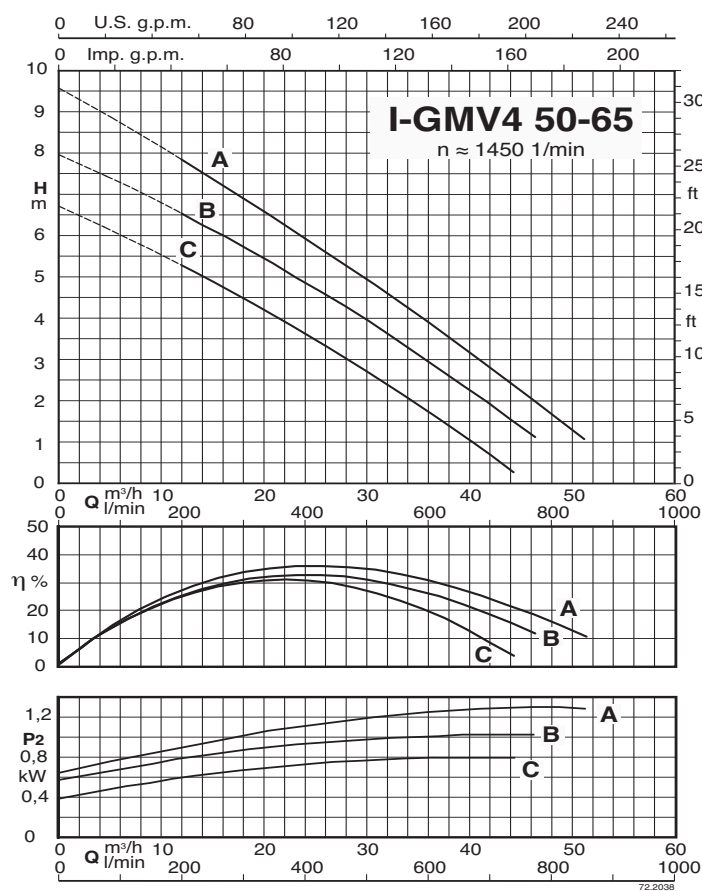
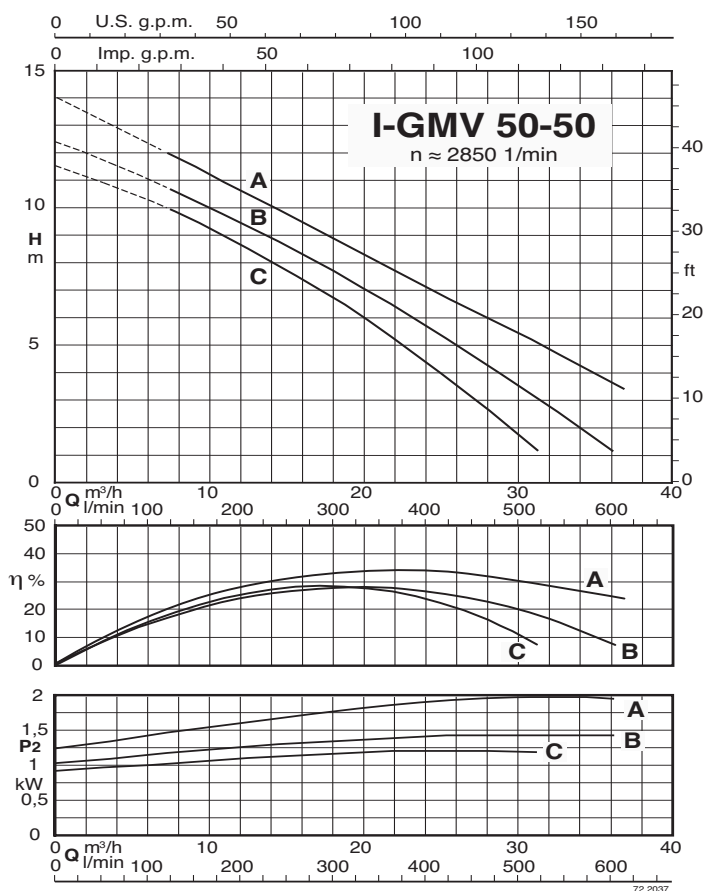

Characteristic curves

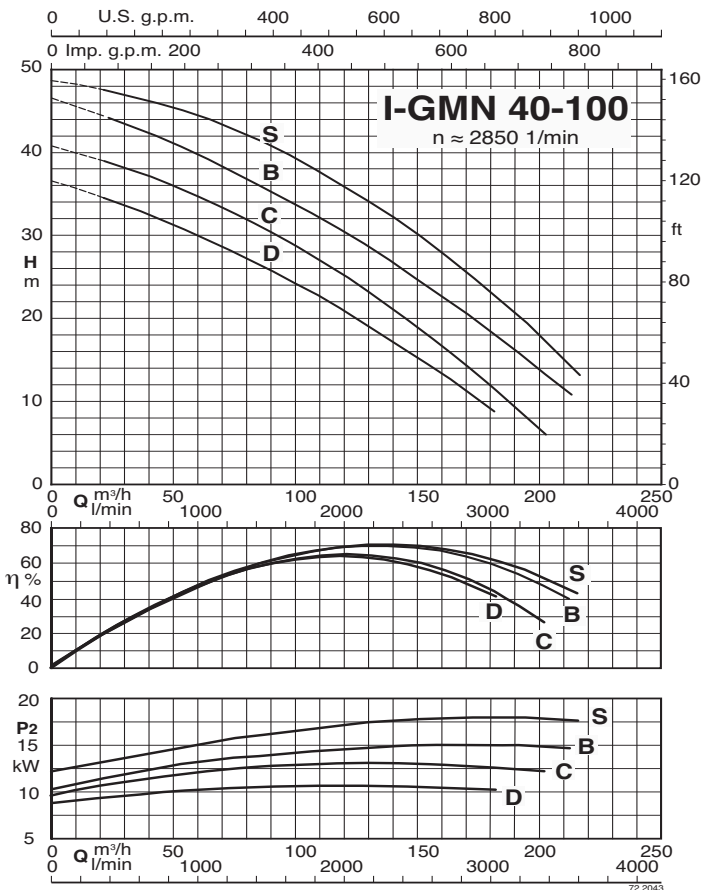
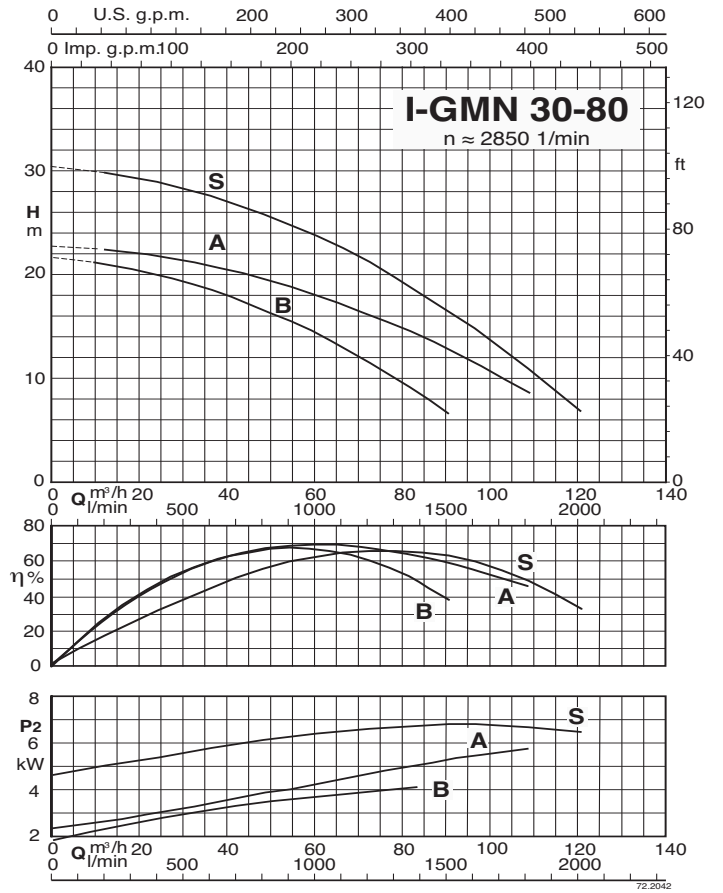
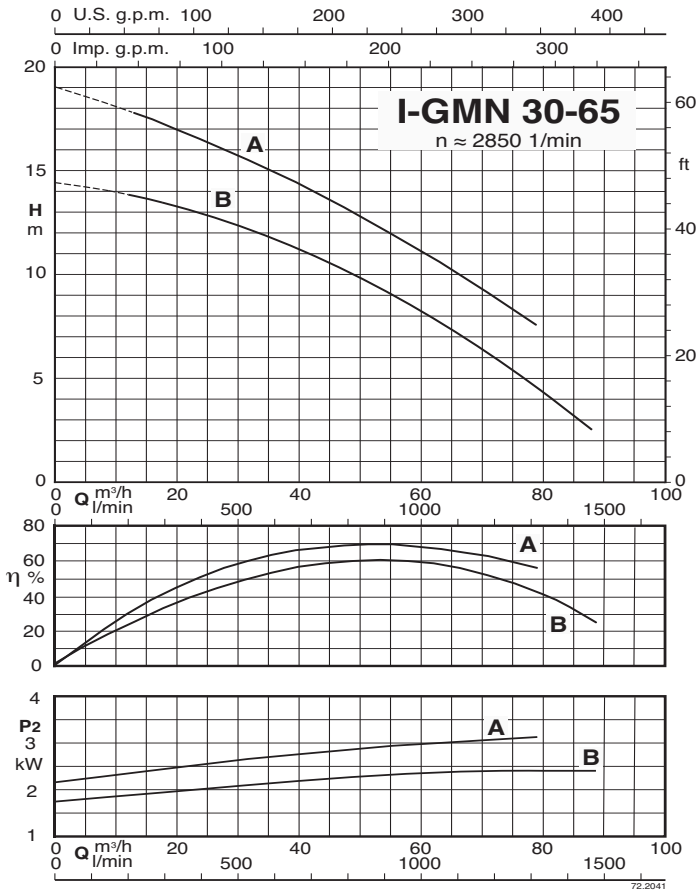

Characteristic curves

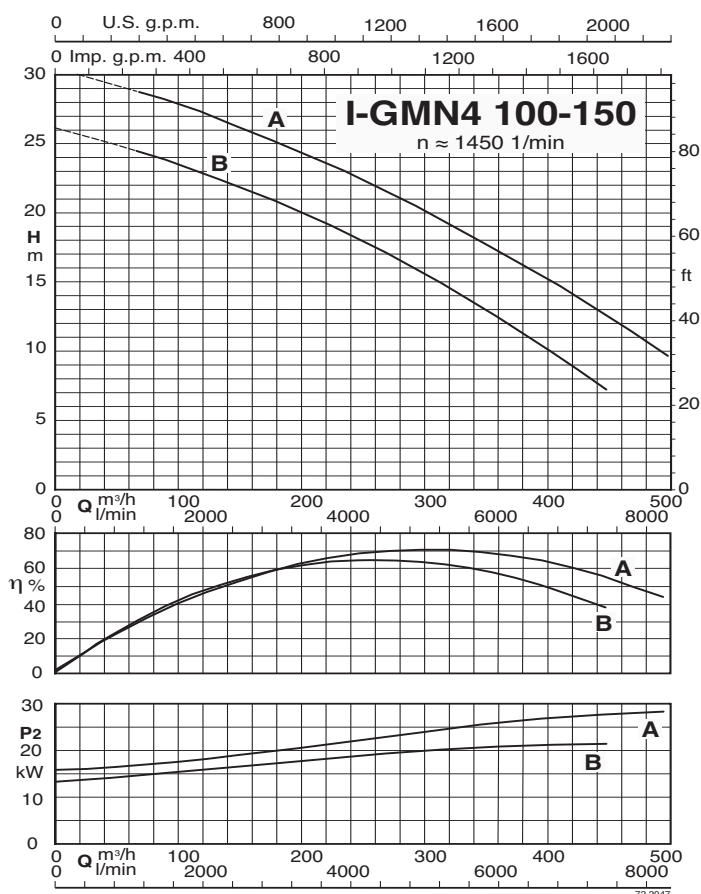
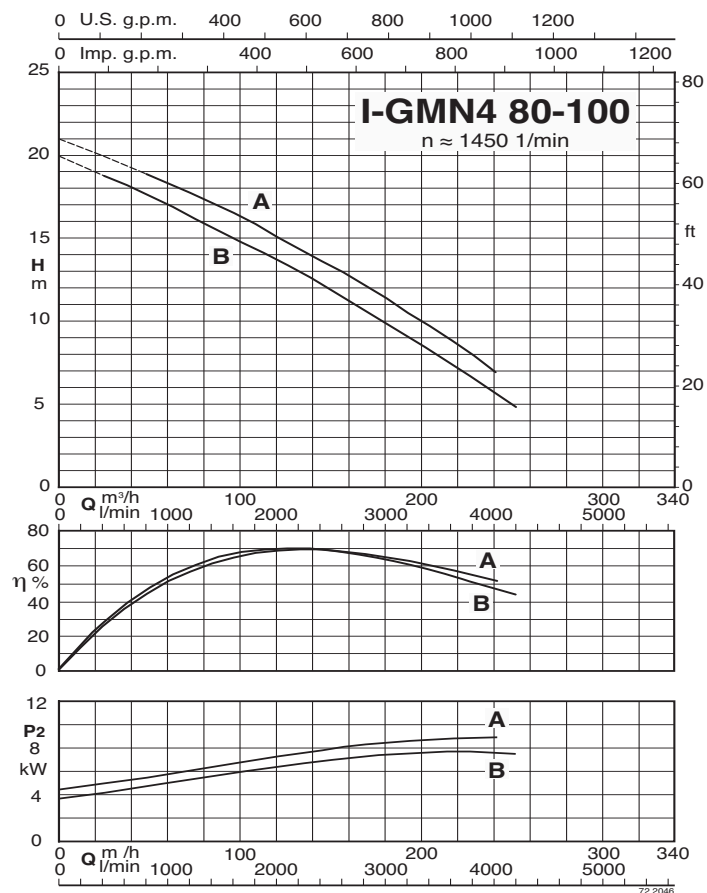
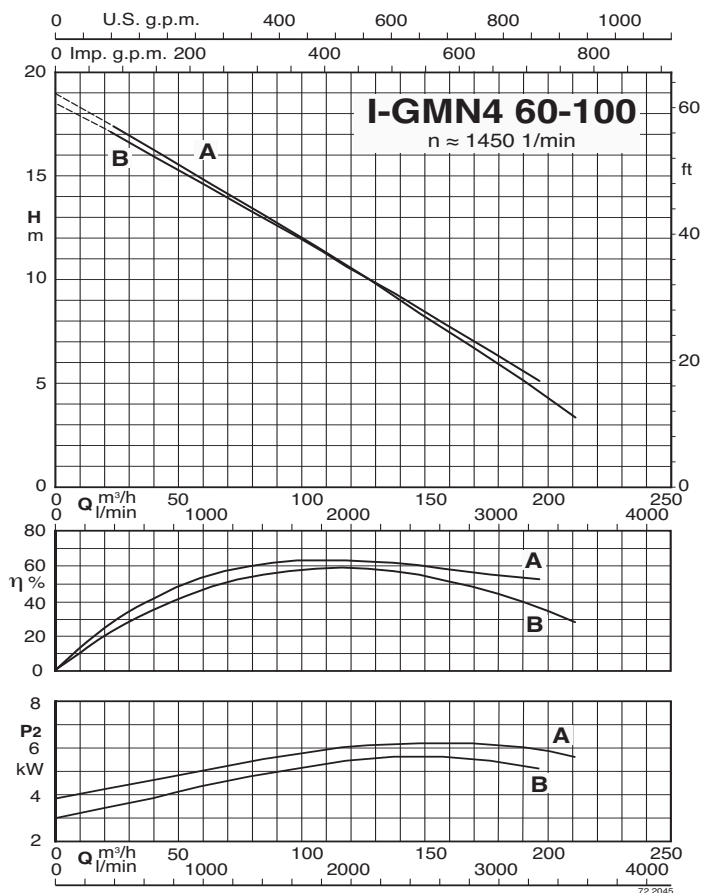

Dimensions and weights

I-GMV 50-50

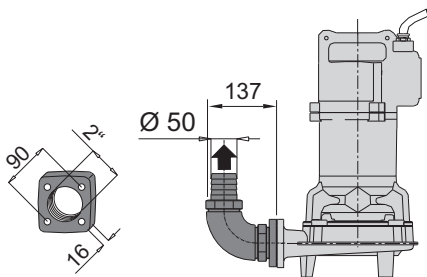
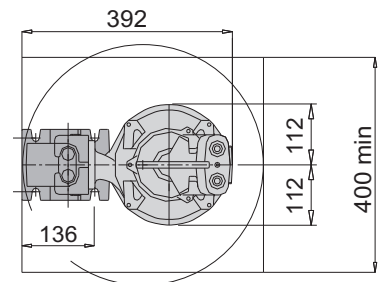
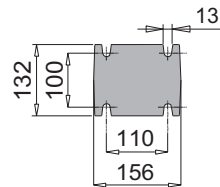
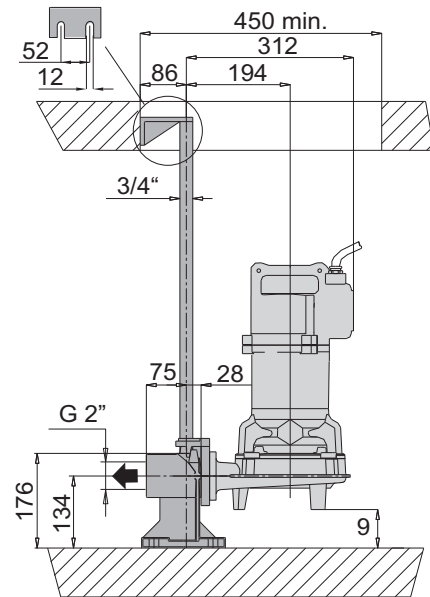
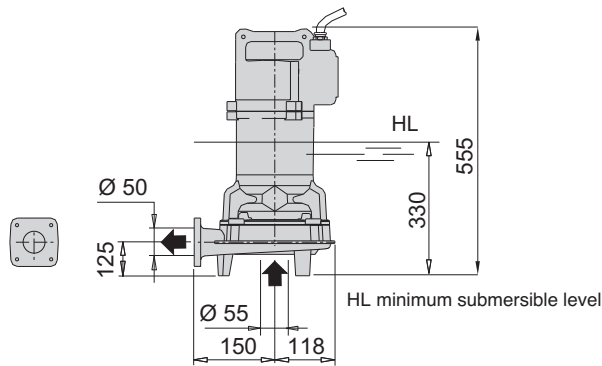

Version with threaded flange and 90° elbow

Version with duck foot coupling

TYPE	Weight kg
I-GMV 50-50C/A	46
I-GMV 50-50B/B	
I-GMV 50-50A/B	

Dimensions and weights

I-GMV4 50-65

I-GMC 40-65

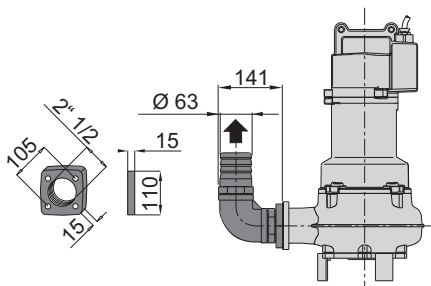
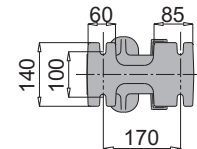
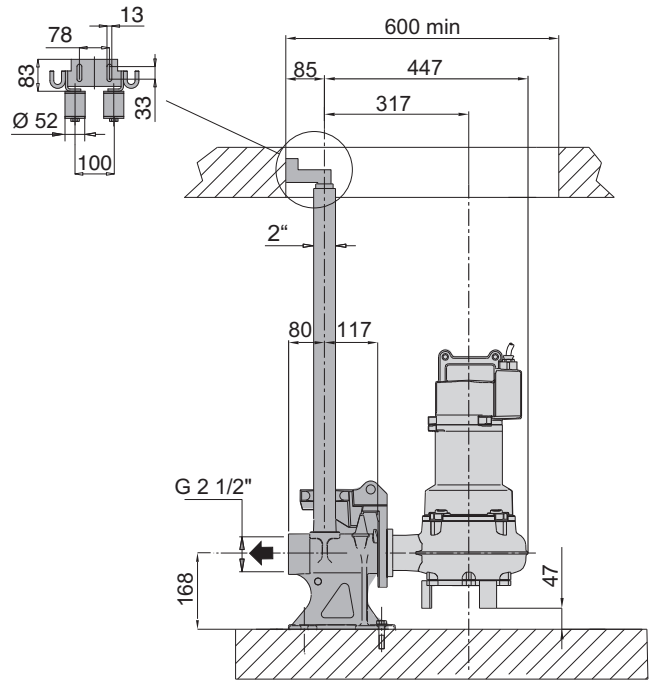
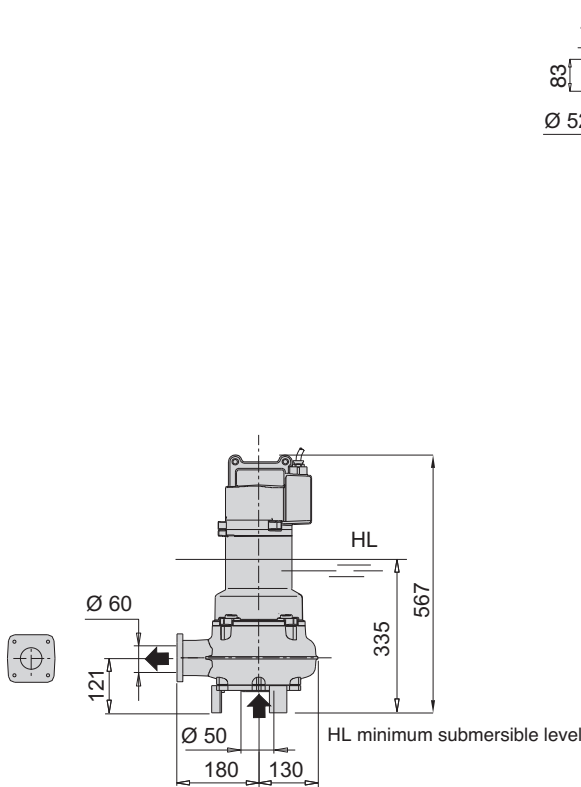

Version with threaded flange and 90° elbow

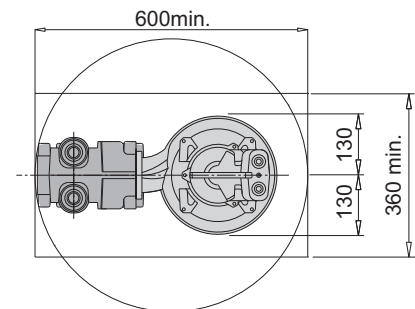

Version with duck foot coupling

TYPE	Weight kg
I-GMV4 50-65C/A	47
I-GMV4 50-65B/A	
I-GMV4 50-65A/A	
I-GMC 40-65B/A	49
I-GMC 40-65A/A	

Dimensions and weights

I-GMN 30-65

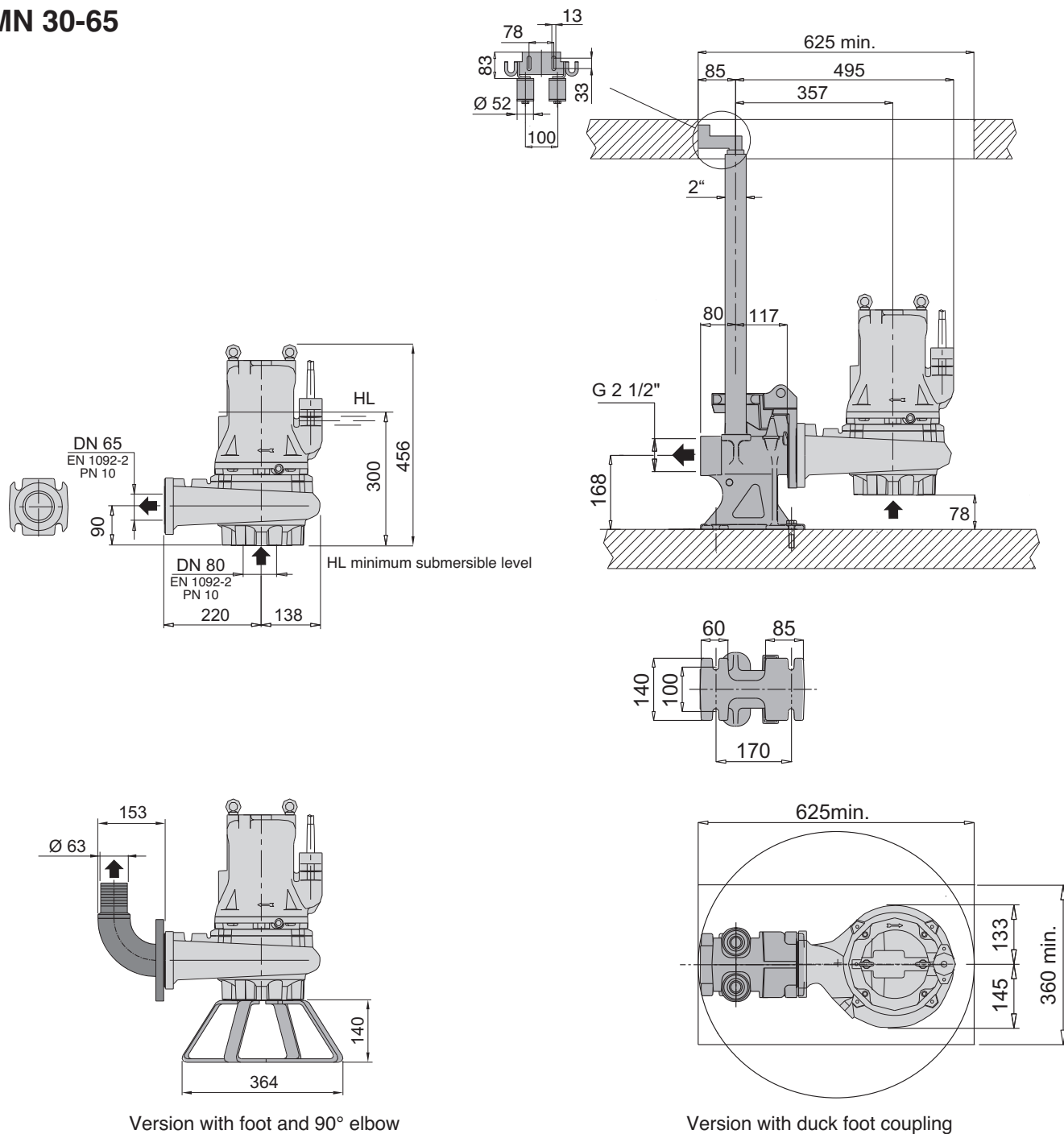

Version with foot and 90° elbow

Version with duck foot coupling

TYPE	Weight kg
I-GMN 30-65B/A	62
I-GMN 30-65A/A	

Dimensions and weights

I-GMV4 50-80

I-GMN 30-80

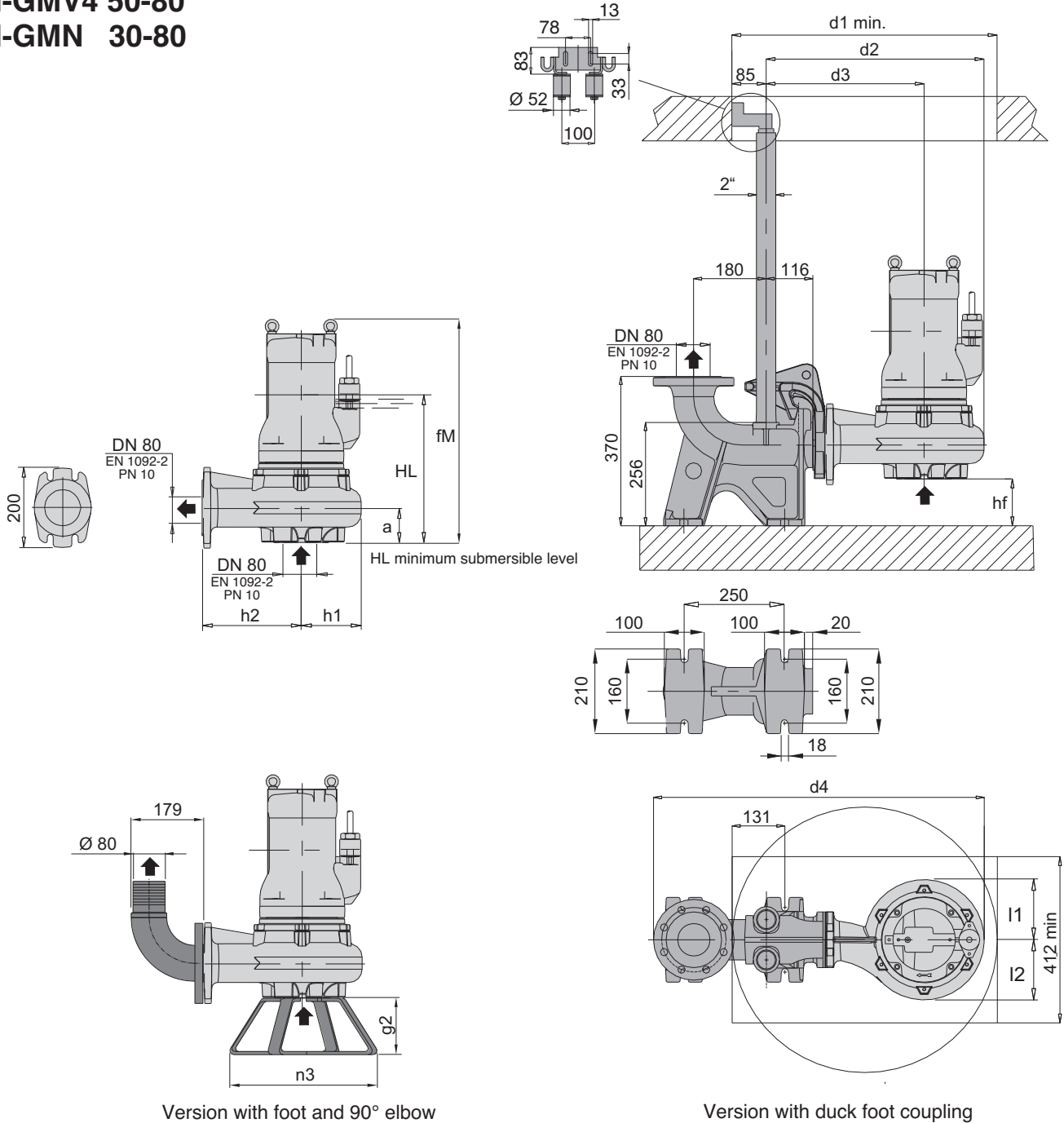

TYPE	EN 1092-2 PN 10		Dimensions mm														Weight kg
	DN1	DN2	fM	HL	hf	a	l1	l2	d1	d2	d3	d4	h1	h2	n3	g2	
I-GMV4 50-80B/A	80	80	519	363	84	116	136	157	658	511	366	791	145	220	370	140	67
I-GMV4 50-80A/A																	
I-GMN 30-80B/A	80	80	515	330	110	90	133	145	700	511	366	791	145	220	370	140	83
I-GMN 30-80A/A																	
I-GMN 30-80S/A	100	80	767	438	132	68	165	165	700	571	386	851	185	220	476	150	170

Dimensions and weights

I-GMN 40-100
I-GMN4 60-100
I-GMN4 80-100

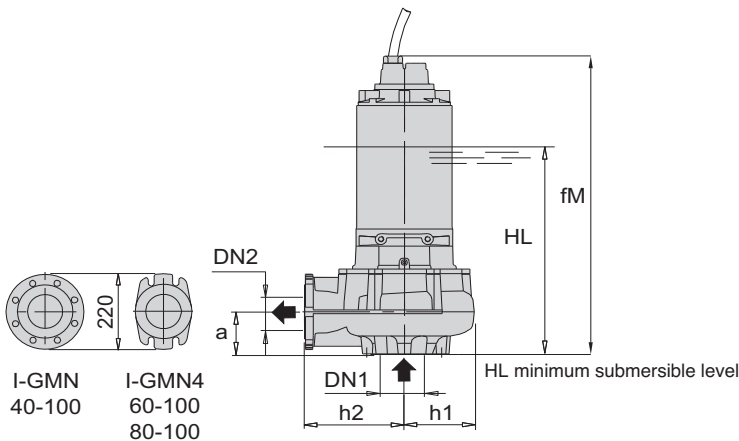

I-GMN 40-100
I-GMN4 60-100
I-GMN4 80-100

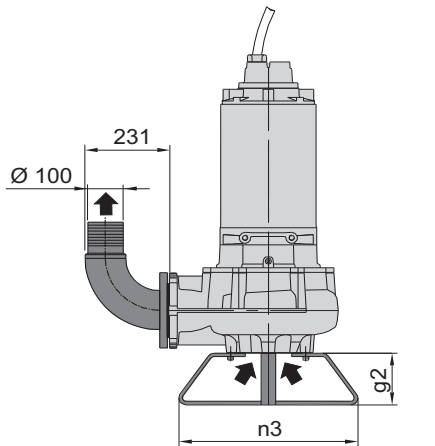
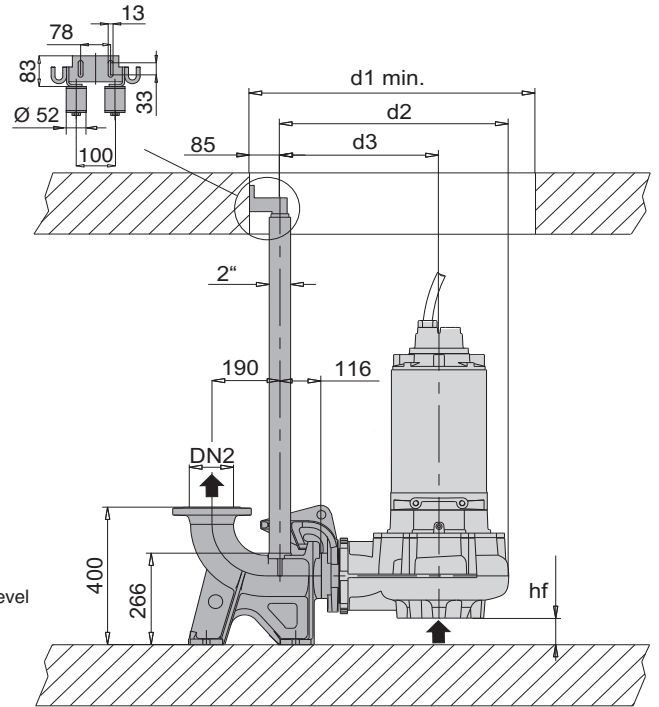

Version with foot and 90° elbow

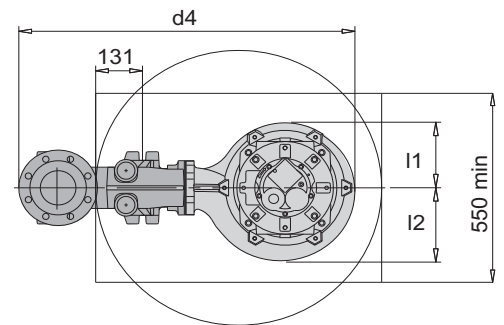
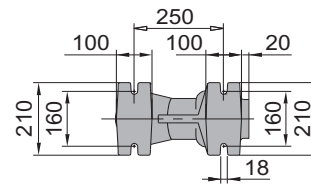

Version with duck foot coupling

TYPE	EN 1092-2 PN 10		Dimensions mm														Weight kg	
	DN1	DN2	fM	HL	hf	a	l1	l2	d1	d2	d3	d4	h1	h2	n3	g2		
I-GMN 40-100D/A	125	100	845	478	127	73	168	184	750	628	441	928	187	275	500	150	222	
I-GMN 40-100C/A																		
I-GMN 40-100B/A																		
I-GMN 40-100S/A	125	100	1269	570	127	73	193	193	800	628	441	928	187	275	500	150	360	
I-GMN4 60-100B/A	125	100	852	526	54	147	189	212	800	640	445	940	195	279	500	150	170	
I-GMN4 60-100A/A																		
I-GMN4 80-100B/A																		
I-GMN4 80-100A/A	125	100	921	570	53	147	189	212	800	640	445	940	195	279	500	150	220	

Dimensions and weights

I-GMN4 100-150

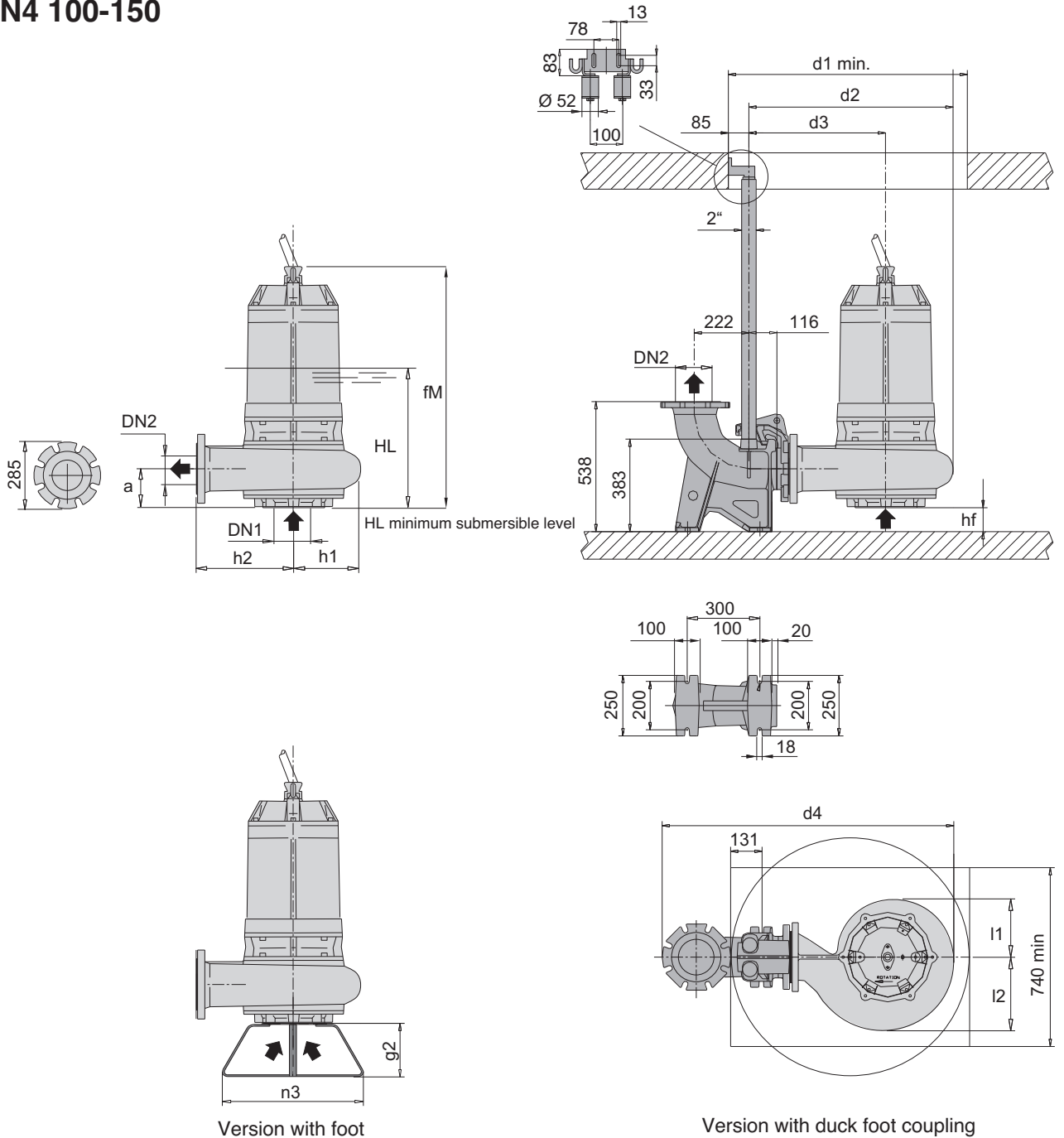

Version with foot

Version with duck foot coupling

TYPE	EN 1092-2 PN 10		Dimensions mm														Weight kg
	DN1	DN2	fM	HL	hf	a	l1	l2	d1	d2	d3	d4	h1	h2	n3	g2	
GMN4 100-150B/A	150	150	991	576	100	160	235	305	990	931	566	1208	280	400	600	225	370
GMN4 100-150A/A			1055	600													405



Construction

Submersible pumps, **B 10 bronze marine** version.

B-GMV with free-flow (vortex) impeller

B-GMC with single-channel impeller

B-GMN with channels impeller

Twin mechanical seal with oil chamber (lip-seal motor side up to 2,4 kW 2 poles).

Delivery connection DN 50-65-80

Applications

Suitable to pump industrial waste water in chemical, and process industries, agricultural and marine areas.

Solid passage from 30 to 50 mm

Operating conditions

Liquid temperature up to 40 °C.

Maximum immersion depth: 20 m (with suitable cable length).

Continuous duty (with pump immersed at minimum level).

Main materials

Pump casing, Motor casing, Motor cover: B 10 bronze marine

Impeller: stainless steel AISI 316

Motor shaft: stainless steel AISI 316L

Screws: stainless steel AISI 316

Mechanical seal motor side: graphite/ceramic/FPM (lip-seal made of nitrile up to 2,4 kW 2 poles).

Mechanical seal pump side: silicon carbide/silicon carbide/FPM

Motor

2 or 4 poles induction, 50Hz

Three-phase version: 400V ± 10%,

400/690V ± 10%

Insulation class: H

Protection degree: IP 68

N° of starting x hour: max 15 with regular intervals

Cable: H07RN-F, length 10 m

Other models: contact our sale office

Classification scheme IE3.

Coverage chart

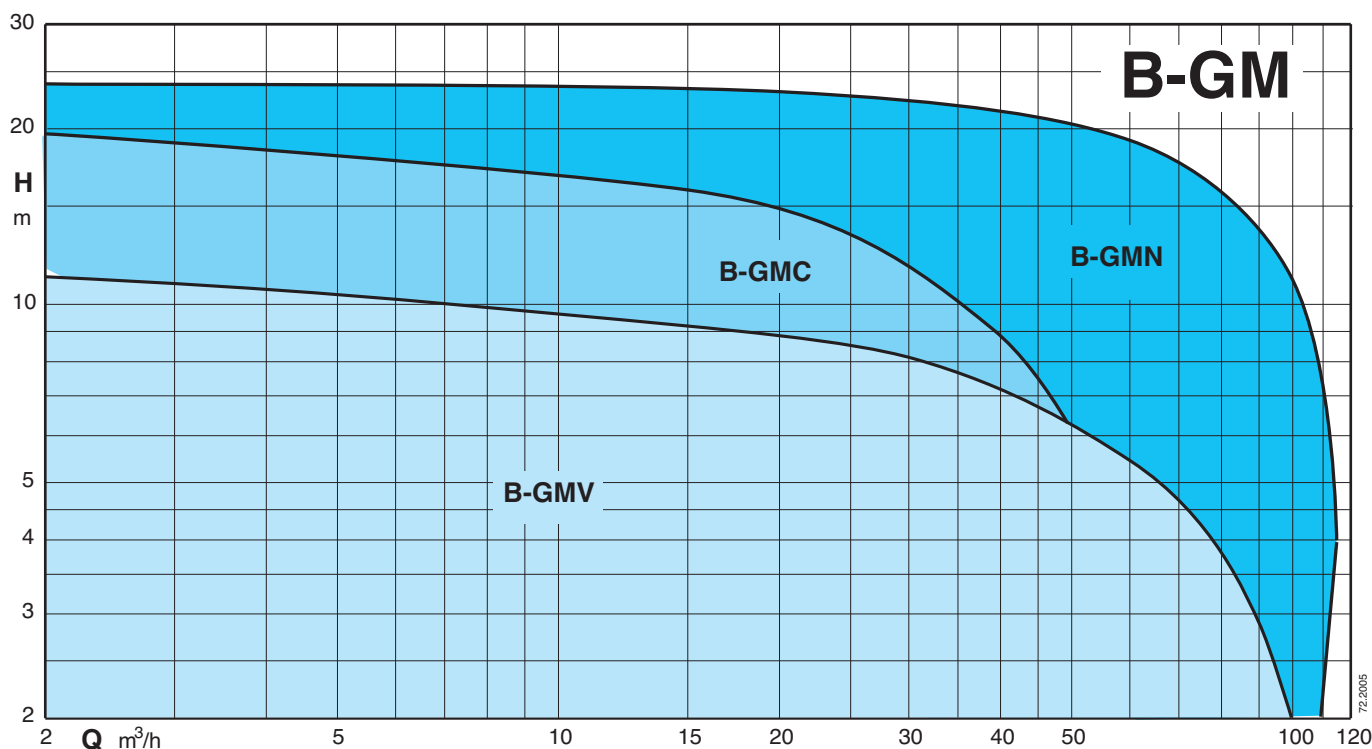

Technical data

TYPE	P ₂ kW	I _N A	Power Supply	r.p.m.	Starting	DN mm	Free passage Ø mm	Thermal protector	Humidity probe	 ATEX Eex
B-GMV 50-50C/A	1,8	3,5	3~ 400V	2850	D.O.L.	50	50	NO	NO	✓
B-GMV 50-50B/B	1,6	3,1	3~ 400V	2850	D.O.L.	50	50	NO	NO	✓
B-GMV 50-50A/B	2,4	4,5	3~ 400V	2850	D.O.L.	50	50	NO	NO	✓
B-GMV4 50-65C/A	1,1	2,4	3~ 400V	1450	D.O.L.	65	50	NO	NO	✓
B-GMV4 50-65B/A	1,4	2,7	3~ 400V	1450	D.O.L.	65	50	NO	NO	✓
B-GMV4 50-65A/A	1,6	3,1	3~ 400V	1450	D.O.L.	65	50	NO	NO	✓
B-GMV4 50-80B/A	2,3	4,4	3~ 400V	1450	D.O.L.	80	50	NO	NO	✓
B-GMV4 50-80A/A	2,8	3,4	3~ 400V	1450	D.O.L.	80	50	NO	NO	✓
B-GMC 40-65B/A	2,1	3,9	3~ 400V	2850	D.O.L.	65	40	NO	NO	✓
B-GMC 40-65A/A	2,8	5,2	3~ 400V	2850	D.O.L.	65	40	NO	NO	✓
B-GMN 30-65B/A	3,1	5,8	3~ 400V	2850	D.O.L.	65	30	NO	NO	✓
B-GMN 30-65A/A	3,6	6,6	3~ 400V	2850	D.O.L.	65	30	NO	NO	✓
B-GMN 30-80B/A	5	9,1	3~ 400/690V	2850	Y/Δ	80	30	●	●	✓
B-GMN 30-80A/A	6,5	11,8	3~ 400/690V	2850	Y/Δ	80	30	●	●	✓

P₂ Rated power outputI_N Rated current

● Standard

✓ ATEX Eex Version on demand

Characteristic curves

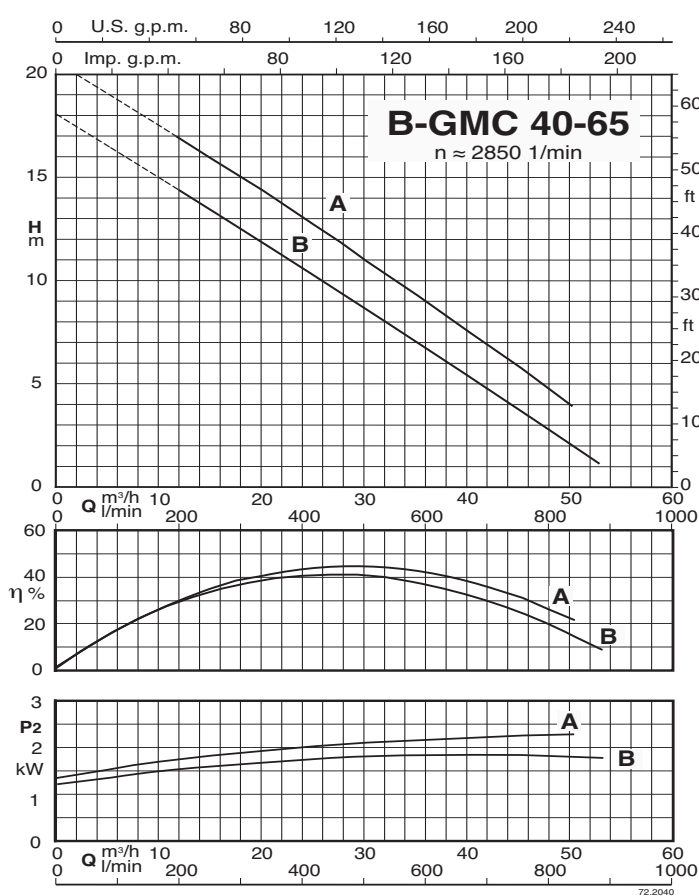
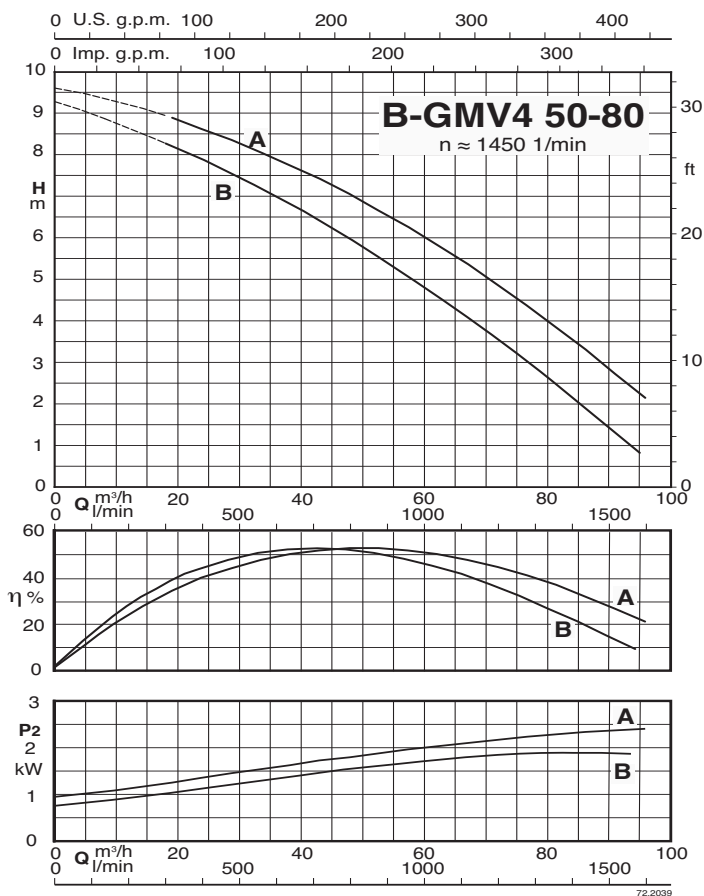
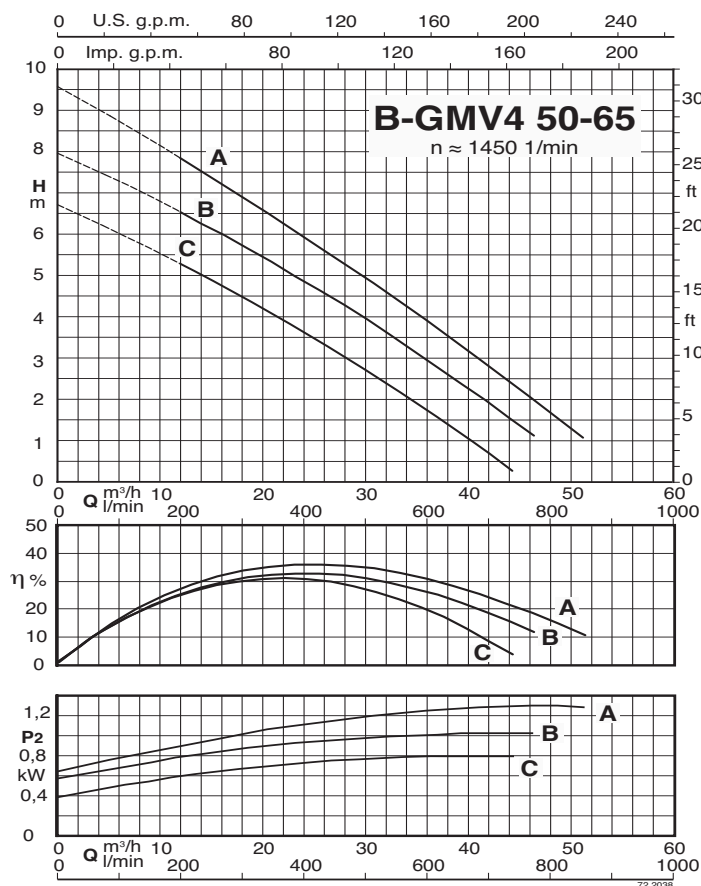
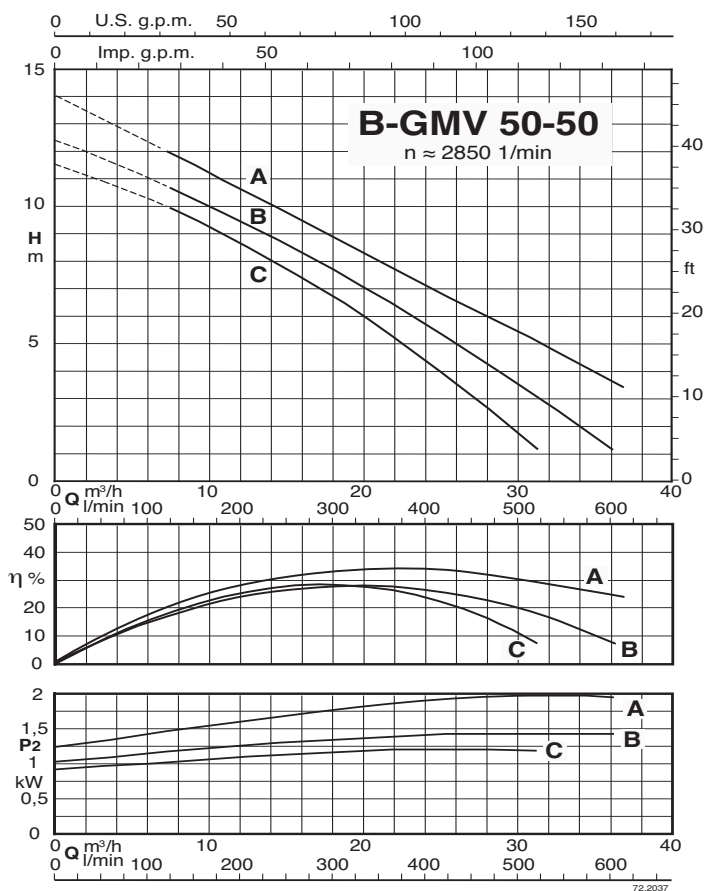

Characteristic curves

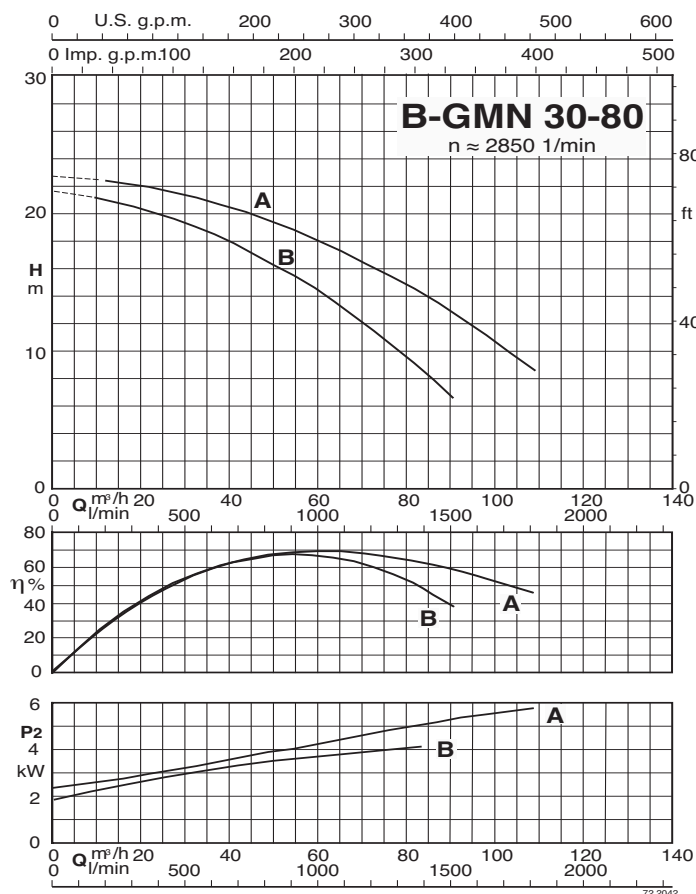
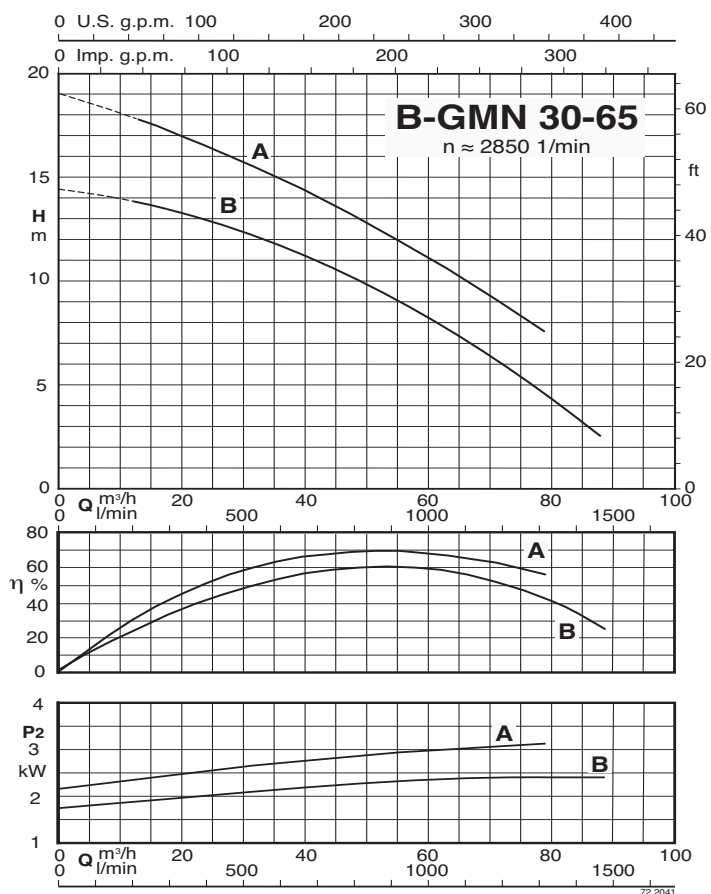

Dimensions and weights

B-GMV 50-50

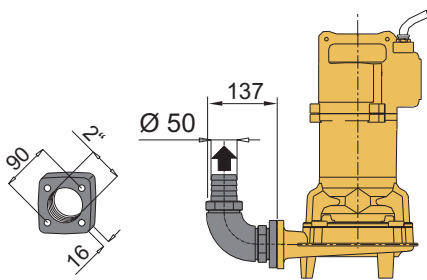
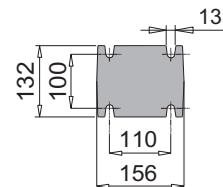
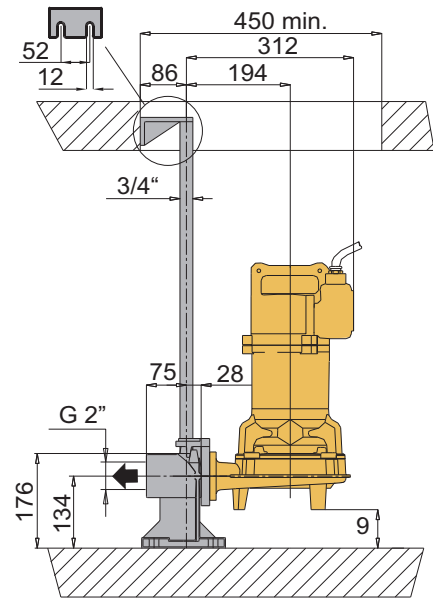
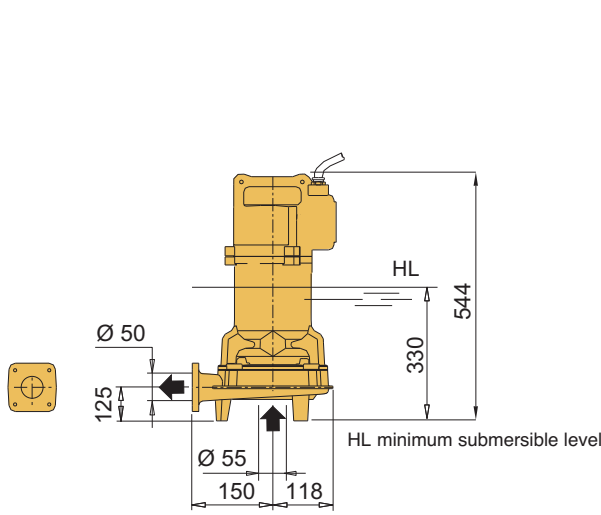

Version with threaded flange and 90° elbow

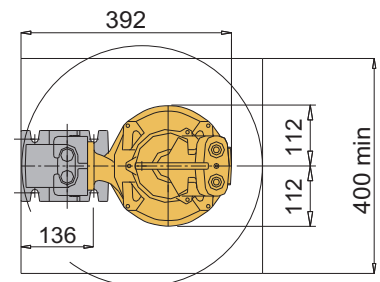

Version with duck foot coupling

TYPE	Weight kg
B-GMV 50-50C/A	48
B-GMV 50-50B/B	
B-GMV 50-50A/B	

Dimensions and weights

B-GMV4 50-65

B-GMC 40-65

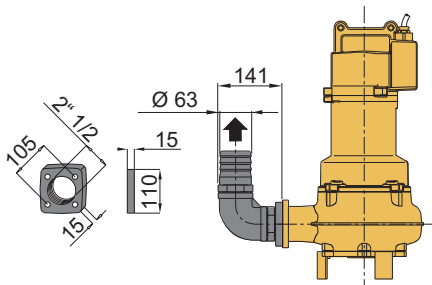
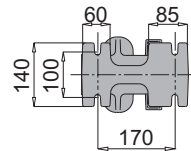
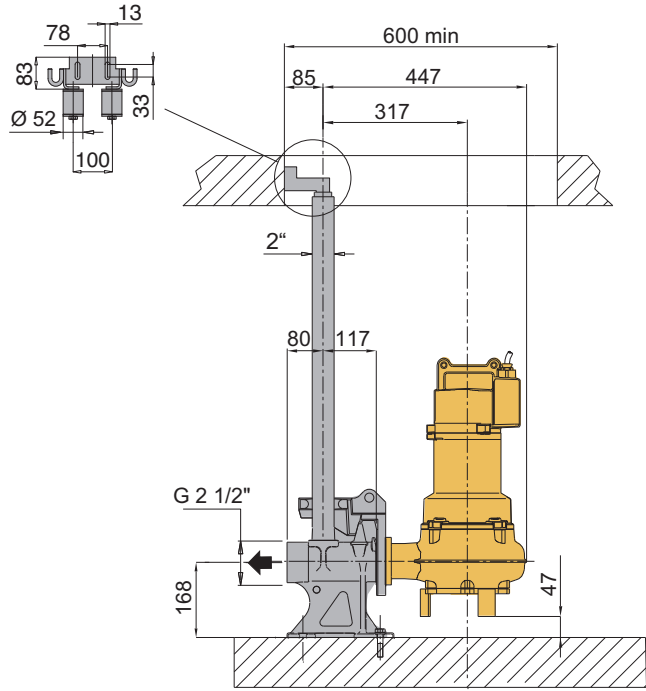
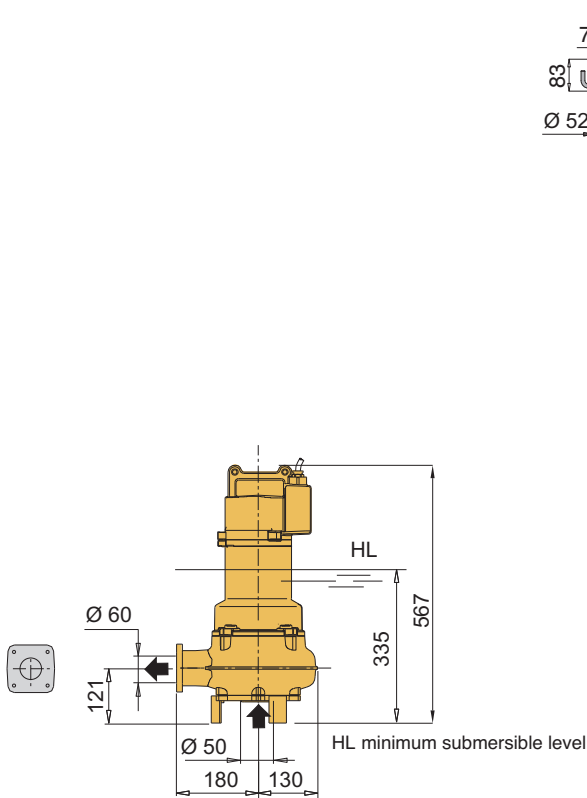

Version with threaded flange and 90° elbow

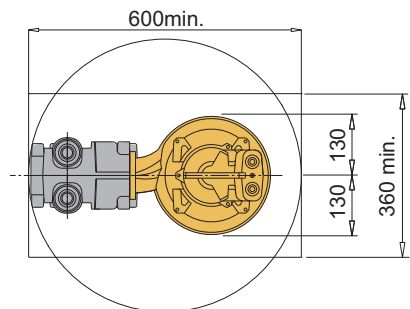

Version with duck foot coupling

TYPE	Weight kg
B-GMV4 50-65C/A	48
B-GMV4 50-65B/A	
B-GMV4 50-65A/A	
B-GMC 40-65B/A	50
B-GMC 40-65A/A	

Dimensions and weights

B-GMN 30-65

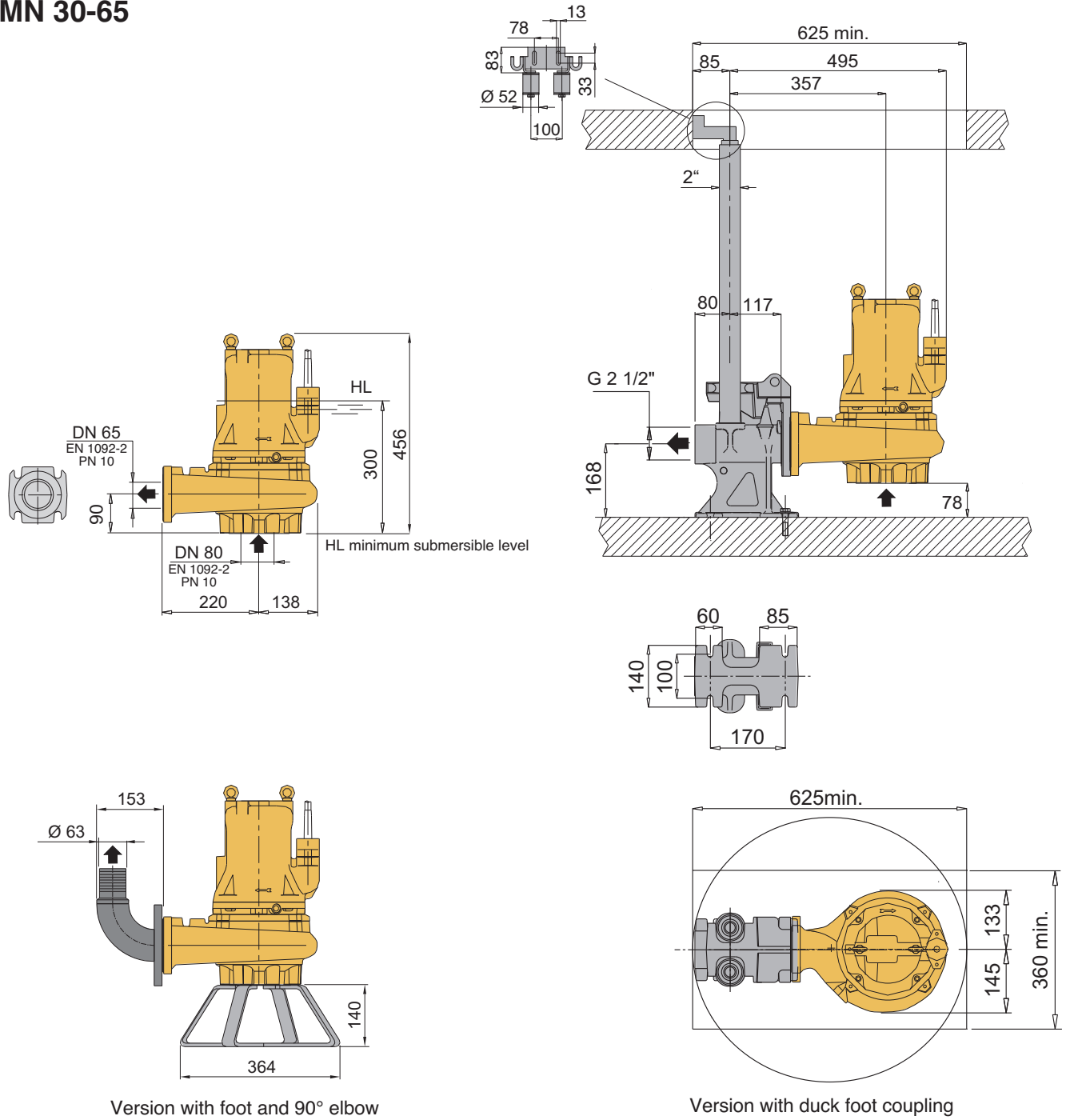

Version with foot and 90° elbow

Version with duck foot coupling

TYPE	Weight kg
B-GMN 30-65B/A	65
B-GMN 30-65A/A	

Dimensions and weights

B-GMV4 50-80
B-GMN 30-80

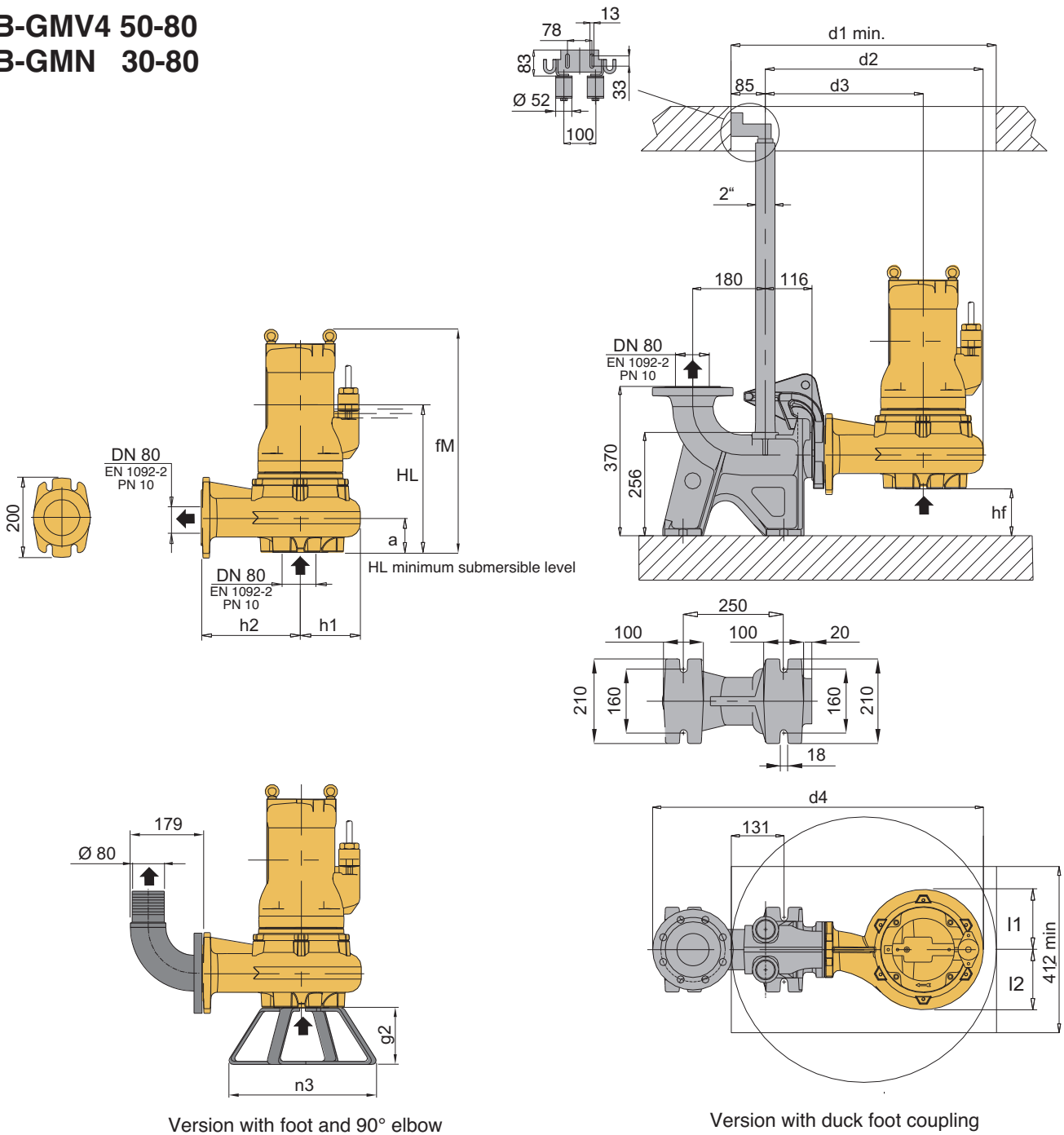

TYPE	EN 1092-2 PN 10		Dimensions mm														Weight kg
	DN1	DN2	fM	HL	hf	a	l1	l2	d1	d2	d3	d4	h1	h2	n3	g2	
B-GMV4 50-80B/A	80	80	519	363	84	116	136	157	658	511	366	791	145	220	370	140	73
B-GMV4 50-80A/A																	
B-GMN 30-80B/A	80	80	515	330	110	90	133	145	700	511	366	791	145	220	370	140	90
B-GMN 30-80A/A																	

Features

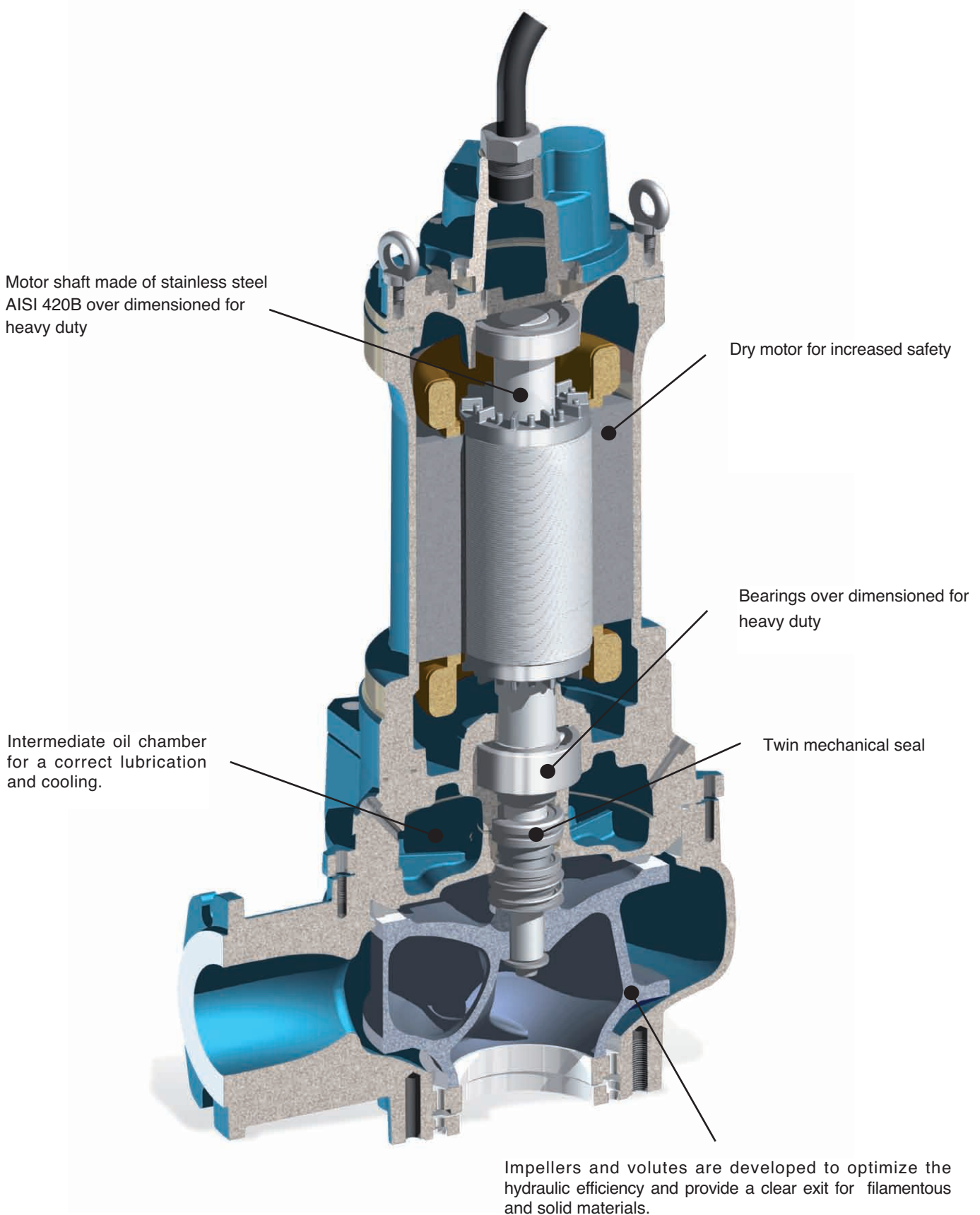

THE IMPELLERS

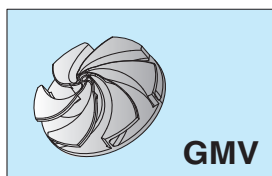

Vortex impeller suitable for pumping liquids containing large solids and/or fibrous materials.
Applications: urban sewerage systems, animal breeding plants.

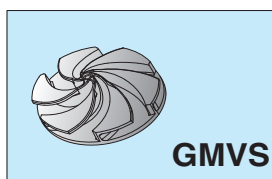

Sand Vortex Water Impeller in Polyurethane with a stainless steel core.
Applications: in plants with a high sand presence, in marble work companies, in the ceramic industry, crystals machining or industrial processes where there's presence of abrasives liquids.

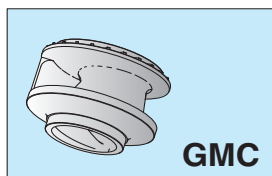

Single channel impeller, for liquids containing fibrous materials and/or suspended solids.
Applications: purification plants, tanneries, animal breeding plants.

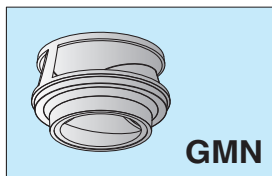

Closed multi-channel impeller, for clean liquids or light solids without filamentous materials.
Applications: large drainage systems, purification plants.

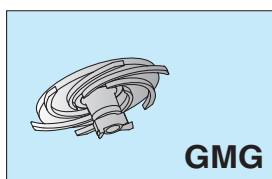

Multi-blade suction impeller with grinder constructed in stainless steel AISI 420, particularly suitable as a grinder for paper or textile materials.
Applications: clearance of waste waters originating from service stations, residential communities, camping sites, etc..

THE STANDARD INSTALLATIONS

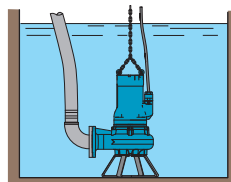

A Mobile and emergency installation with x-foot support

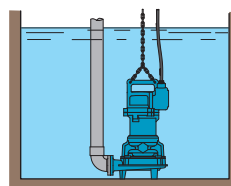

B Free installation and threaded elbow

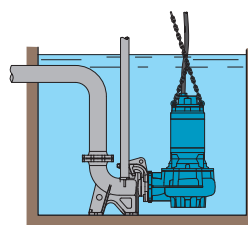

C Fixed installation with automatic coupling feet and guide rails.

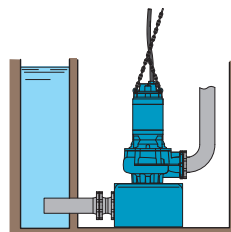

D Dry pit installation, with x-foot rest and suction bend.
 Pump equipped with cooling jacket.

Installation with duck foot coupling

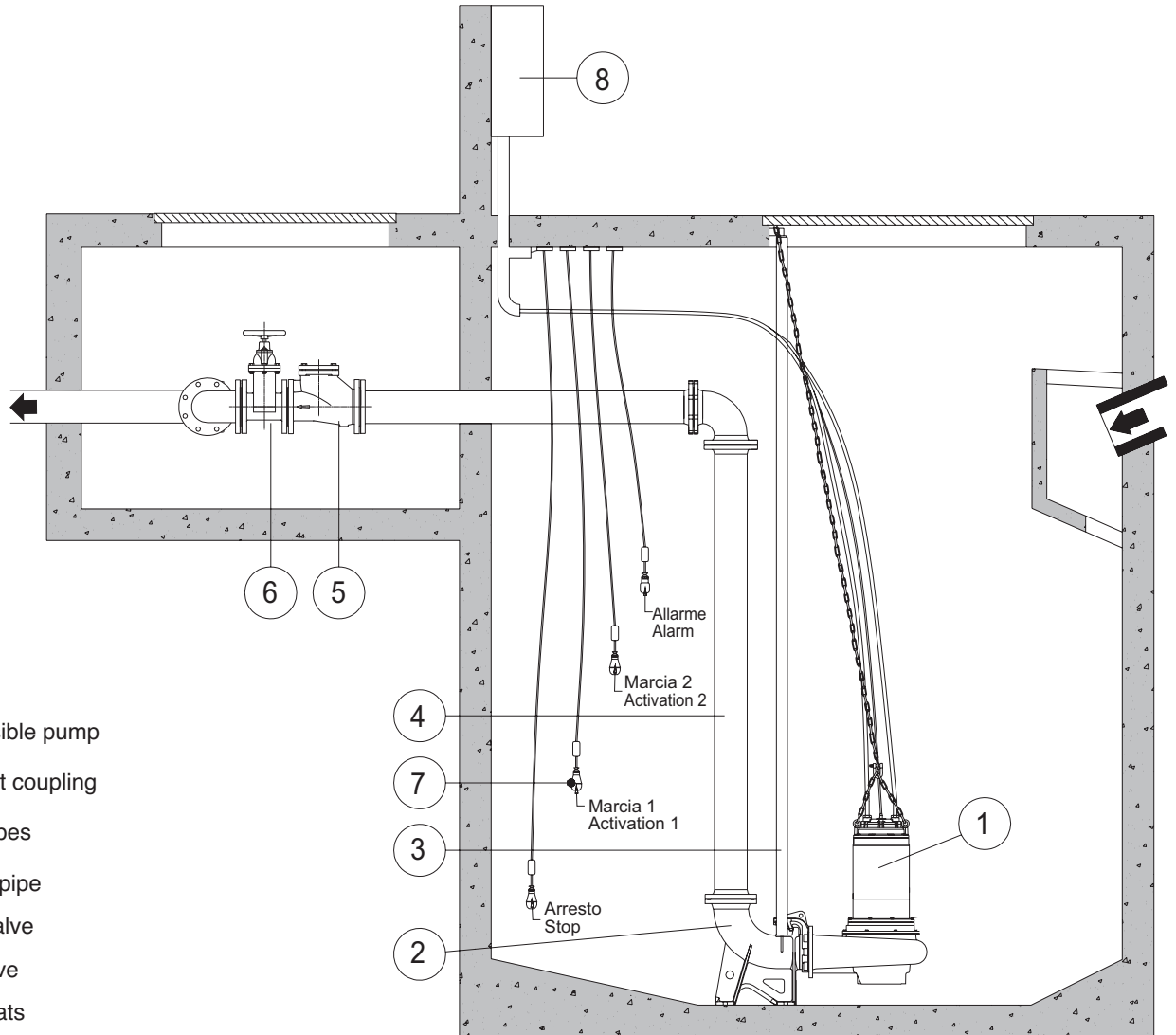

- 1 Submersible pump
- 2 Duck foot coupling
- 3 Guide pipes
- 4 Delivery pipe
- 5 Check valve
- 6 Gate valve
- 7 Level floats
- 8 Control box

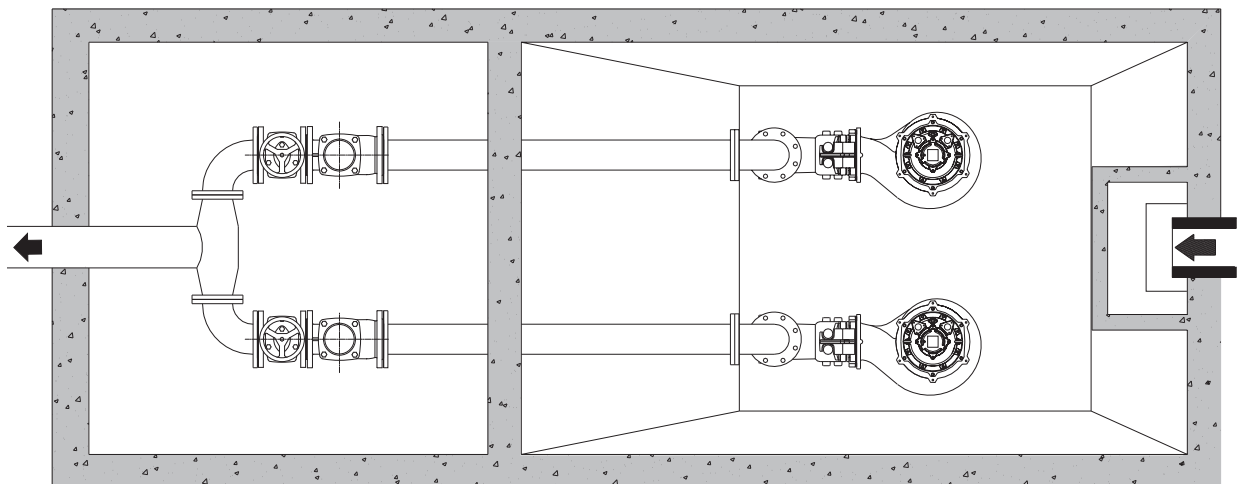

Accessories

Non-return ball valves

Construction

Non-return self-cleaning ball valves, suitable for dirty and viscous liquids, sewage water.

Operating conditions

Working temperature from -10°C up to +80°C

Rated pressure: 10 bar

Vertical or horizontal installation

Materials

Valve body: Cast iron EN-GJL-250

Cover: Cast iron EN-GJL-250

Ball: Resin for threaded VNRP

Resin + nitril for VNRP DN 50-100

Cast iron + nitril for VNRP DN 125-250

Screws: SS AISI 304

Joint: nitril

Dimensions

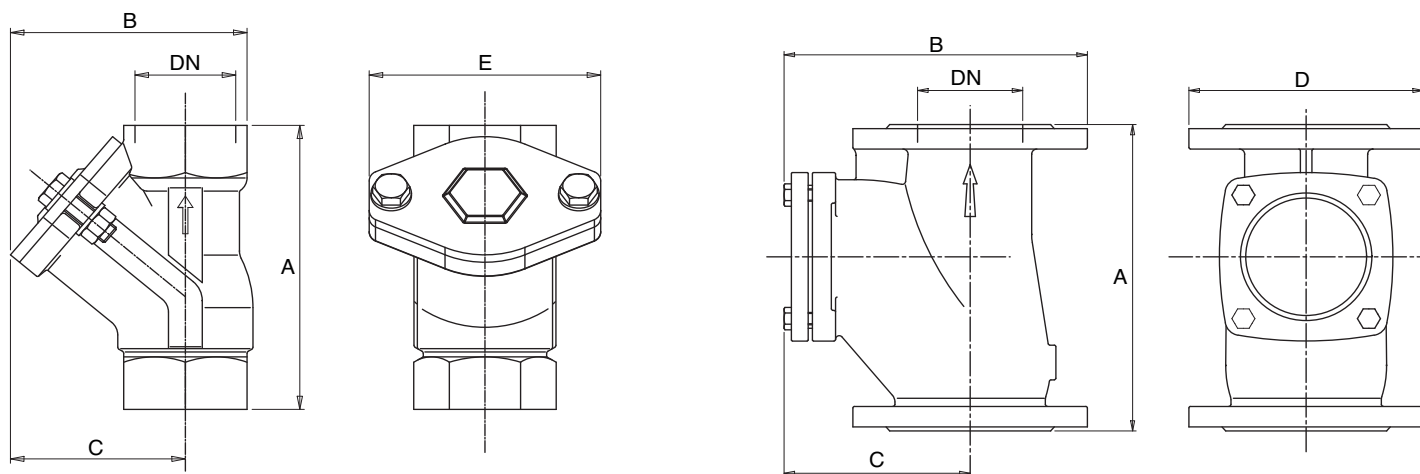

TYPE	DN mm	mm				Weight kg
		A	B	C	E	
VNRP 1 1/4	1" 1/4	132	111	83	108	1,9
VNRP 1 1/2	1" 1/2	145	122	90	120	2,4
VNRP 2	2"	173	145	110	135	3,6
VNRP 2 1/2	2" 1/2	200	175	130	155	6,5

TYPE	DN mm	mm				Weight kg
		A	B	C	D	
VNRP 50	50	182	192	120	165	9,5
VNRP 65	65	204	215	124	185	14
VNRP 80	80	260	250	150	200	19,5
VNRP 100	100	300	290	180	220	23,5
VNRP 125	125	350	340	215	250	36
VNRP 150	150	400	388	245	285	38,5
VNRP 200	200	500	480	310	340	69