



HiLobe®

The next generation of Roots pumps. Intelligent, high-performance
Roots pumps for low and medium vacuum applications.

PFEIFFER  **VACUUM**

The next generation of Roots pumps. Intelligent, high-performance Roots pumps for low and medium vacuum applications.

Perfectly adjustable

Roots pumps from the innovative HiLobe series offer a wide range of pumping speeds and applications. With their individual speed control, they can be adapted perfectly to customer-specific requirements. In order to operate, Roots pumps require a suitable backing pump for the application in hand, which is adjusted to the gas flow. Installation costs are reduced due to the flexible mounting position.

High performance

The superior drive concept of the HiLobe pumps can shorten pump-down times by about 20% compared to conventional Roots pumps, especially for rapid evacuations. The pumps are hermetically sealed from the atmosphere and offer a maximum integral leak rate of $1 \cdot 10^{-6}$ Pa m³/s.

Low operating costs

The HiLobe series offers the lowest operating costs with the most uptime. This is achieved by using only motors with very high energy efficiency, even at different operating ranges, and optimized rotor geometries. The sealing concept makes the use of sealing gas superfluous in many cases, which reduces operating costs even more. Cost-intensive water cooling is no longer necessary due to the sophisticated air cooling concept.

Intelligent

The intelligent interface technology of the HiLobe ensures optimal adjustment and condition monitoring of processes. Intelligent condition monitoring also guarantees a long service life and maximum operational reliability.

Applications

- Electron beam welding
- Leak detection
- Metallurgy
- Coating
- Freeze drying
- Space simulation
- Vacuum packaging
- Battery production
- Vacuum drying, including transformer drying
- Insulation vacuum
- Distillation



Customer benefits

- Pumping speed range, depending on version, from 260 –6,200 m³/h due to variable speed control
- Extremely short pump-down times due to superior, next-generation drive concept
- Intelligent interface technology allows process adjustment and condition monitoring (Industry 4.0)
- Hermetically sealed pump with leak rate of $< 1 \cdot 10^{-6}$ Pa m³/s since outward dynamic seals are eliminated
- Low operating costs due to state-of-the-art air cooling up to +40 °C and motor technology (surpasses the IE4 standard for asynchronous motors)
- Long service life and maximum operational reliability thanks to intelligent condition monitoring and innovative rotor/motor concept.



Coating



Automotive industry



Electron beam welding



Steel degassing



Electron beam welding



Freeze drying

We promote sustainable solutions



Energy-saving and durable

Integrating modern HiLobe Roots pumps is a sustainable and environmentally friendly way to increase the efficiency of pumping stations. In addition to a long service life and high operational reliability, these pumps feature motors that already meet the future IE4 energy efficiency class. This also applies for a variety of operational areas (such as load lock, ultimate pressure). Thus they significantly contribute to reducing operating costs and energy use in particular. Thanks to the sophisticated ventilation concept of the HiLobe, complex water cooling can also be dispensed with, thereby saving resources and reducing your operating costs.

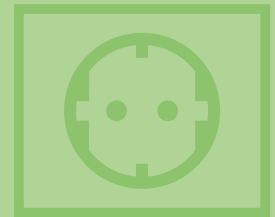

Sustainability and social responsibility

Our CombiLine pumping stations are all optimally adapted to your process by our experts to find the most cost-effective and efficient solution for your application.

When procuring the various components and manufacturing our pumps, Pfeiffer Vacuum places the utmost importance on fair business practices, an employee-oriented human resources policy, economical use of natural resources, as well as climate and environmental protection.



The next generation of Roots pumps. Intelligent, high-performance Roots pumps for low and medium vacuum applications.

Innovative drive

The new, integrated and wear-free drive of the HiLobe series is hermetically sealed. The IE4 energy-efficiency-class motor also reduces operating costs.

Hermetically sealed with integrated motor (IPM – interior permanent magnet)

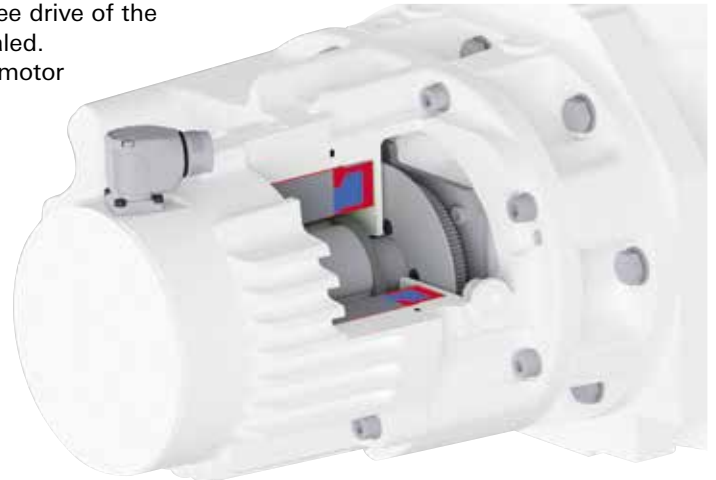

Comparison of costs for maintenance and energy

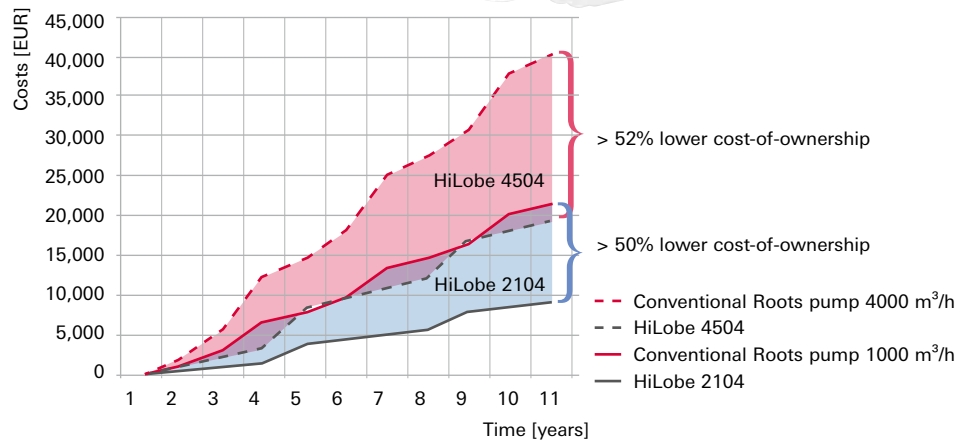

Flexible air cooling

The individual temperature control of the HiLobe by controlling the air cooling ensures pump temperatures are ideally adjusted to each process.

Comparison of versions

	Integrated air cooling and frequency converter	Frequency converter and connection cable included in delivery	Low space requirements	Pumping speeds
HiLobe 1302		■	■	up to 1,300 m³/h
HiLobe 2104	■	■	■	up to 2,100 m³/h
HiLobe 4504/6204	■	■	■	up to 6,200 m³/h

Size and mounting options



HiLobe 1302, vertically mounted, with convection cooling, separate frequency converter and connection cable



HiLobe 1302, horizontally mounted, with convection cooling, separate frequency converter and connection cable



HiLobe 2104, vertically mounted, with integrated air cooling, frequency converter and connection cable



HiLobe 2104, horizontally mounted, with integrated air cooling, frequency converter and connection cable



HiLobe 4504/6204, vertically mounted, with air cooling, separate frequency converter and connection cable



HiLobe 4504/6204 horizontally mounted, with integrated air cooling, separate frequency converter and connection cable

Pumping speed curves, pump-down curves and dimensional drawings

Pumping speeds

HiLobe 1302/2104

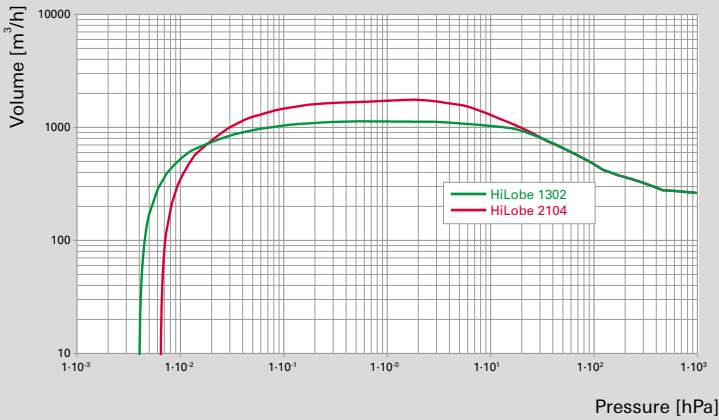

Pump-down curves

for 400 l volume, with Hepta 300 backing pump

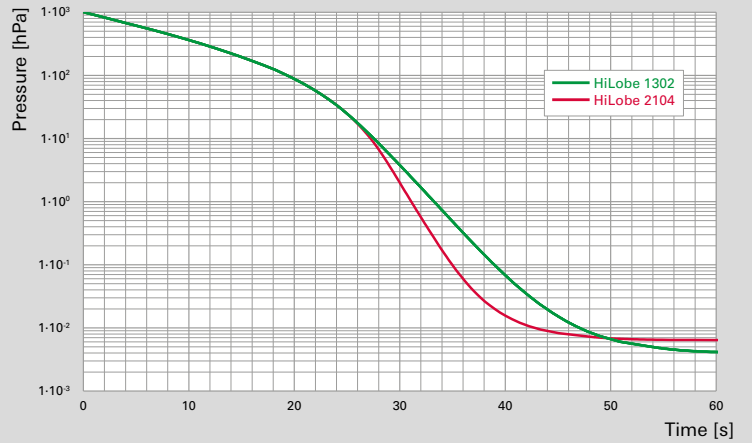

HiLobe 4504/6204

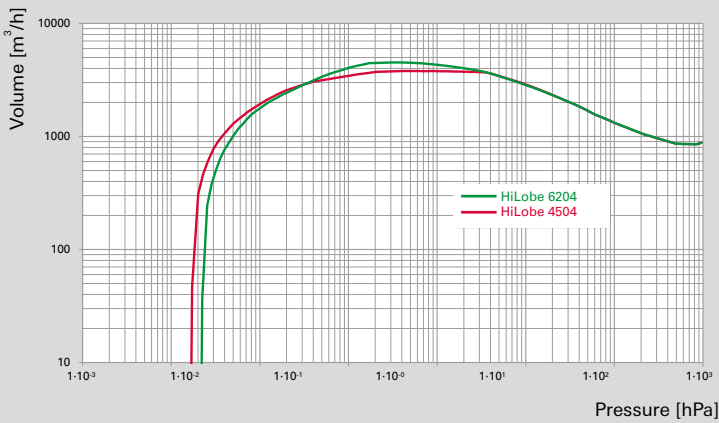

for 1800 l volume, with Hepta 950 L backing pump

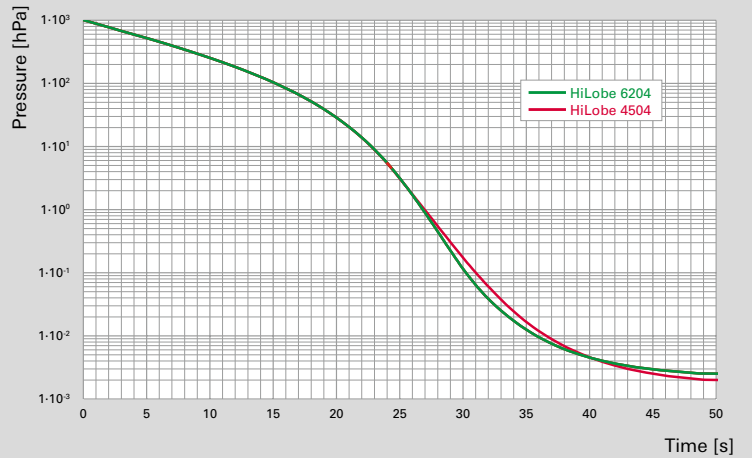

Dimensional drawing

HiLobe 1302

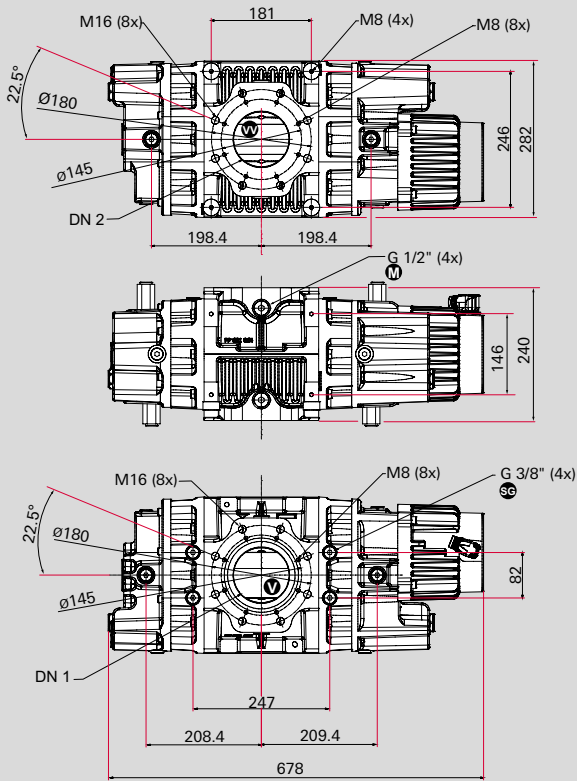

HiLobe 2104

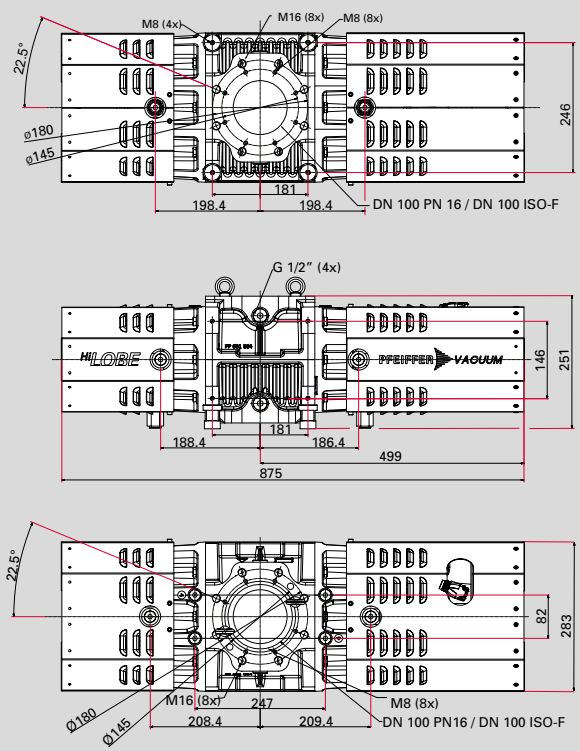

HiLobe 4504/6204

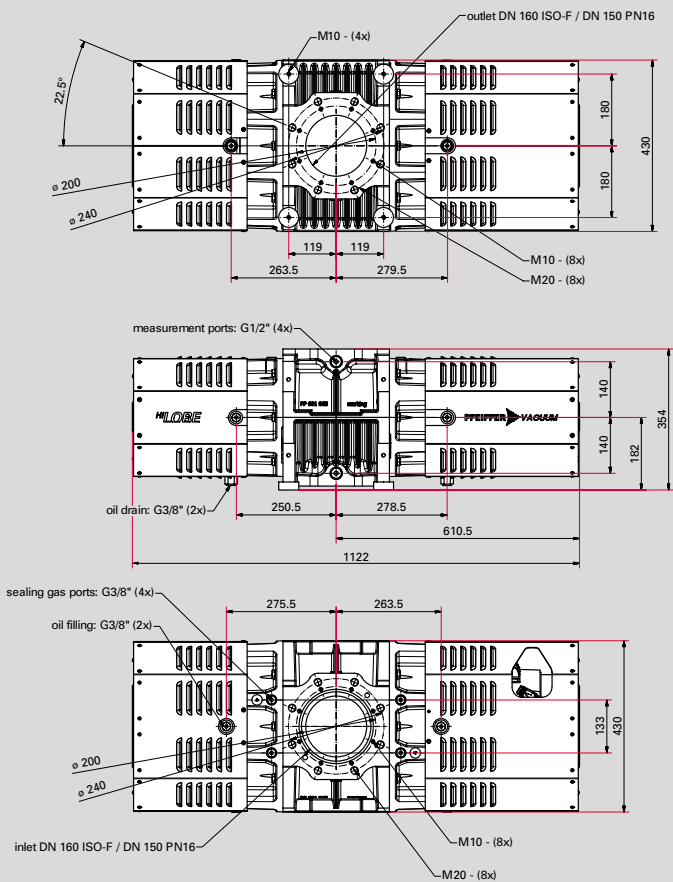

RC 5500 / RC 7500

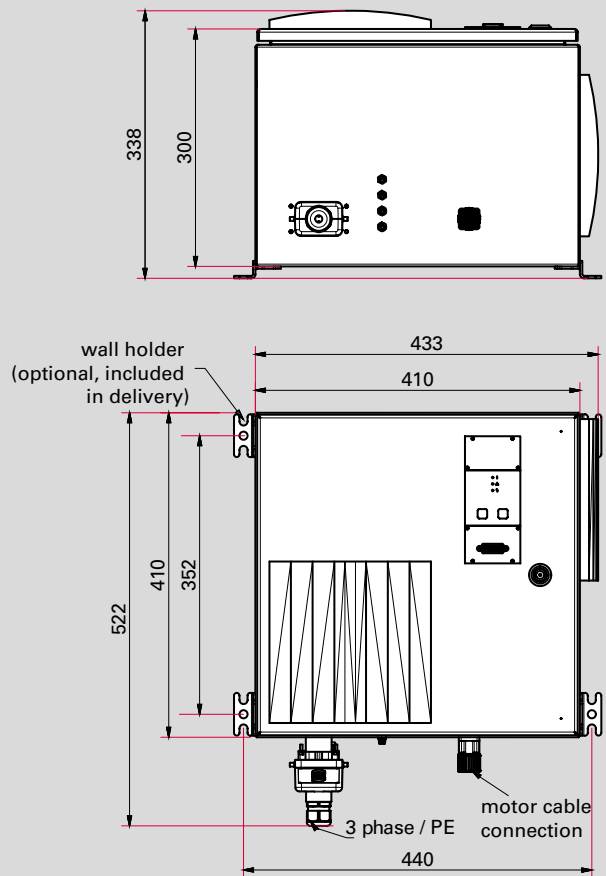

Dimensions in mm

Technical data, order number matrix and accessories

Technical data

	HiLobe 1302	HiLobe 2104	HiLobe 4504	HiLobe 6204
Flange (in)	DN 100 ISO-F DN 100 PN 16		DN 160 ISO-F DN 150 PN16	
Flange (out)	DN 100 ISO-F DN 100 PN 16		DN 160 ISO-F DN 150 PN16	
Mounting orientation	0° (HV flange up) 90° (HV flange at the side)			
Cooling type, standard	Air, natural convection	Air, integrated convection		
Motor protection	PTC			
Maximum differential pressure at maximum speed	13 hPa	12 hPa	17 hPa	10 hPa
Maximum differential pressure at minimum speed	41 hPa	75 hPa	50 hPa	
I/O interfaces	RS -485, PV.can			
Nominal pumping speed	260–1,300 m ³ /h	260–2,100 m ³ /h	890–4,440 m ³ /h	890–6,220 m ³ /h
Speed	1,500–7,500 rpm	1,500–12,000 rpm	1,500–7,500 rpm	1,500–10,500 rpm
Integral leak rate	< 1 · 10 ⁻⁶ Pa m ³ /s			
Emission sound pressure level (EN ISO 2151) at intake pressure 1 hPa and nominal speed	60 dB(A)	69 dB(A)	65 dB(A)	
Operating voltage/frequency	305–528 V AC, 50/60 Hz			
Nominal power at maximum speed	2.5 kW	3.5 kW	5.5 kW	7.5 kW
Operating fluids	D1			
Operating fluid quantity	0.65 l		3.2 l	
Dimensions (L x W x H)	678 x 282 x 240 mm	875 x 282 x 240 mm	1112 x 430 x 354 mm	
Protection class	IP54			
Ambient temperature	5 – 40 °C			
Weight	105 kg	115 kg	280 kg	

Size and direction of flow	a
HiLobe 1302 – 2104 – Vertical	2
HiLobe 1302 – 2104 – Horizontal	3
HiLobe 4504 – 6204 – Vertical	4
HiLobe 4504 – 6204 – Horizontal	5

Maximum pumping speed [m ³ /h]	b
HiLobe 1302 = 1,300 m ³ /h HiLobe 4504 = 4,500 m ³ /h	1
HiLobe 2104 = 2,100 m ³ /h HiLobe 6204 = 6,200 m ³ /h	2

Cooling ¹⁾	c
Convection cooling ²⁾	2
Integrated air cooling	4

Electronic drive unit	d
RC (Roots control), 305-528 V, 50/60Hz	0
RC (Roots control), 180-260 V, 50/60Hz	2

Operating fluids	e
P3	0
D1	1

¹⁾ Alternative version on request

²⁾ Only for HiLobe 1302

General accessories

Accessories	Order number
Controller/cable	
HPU 001, Handheld Programming Unit	PM 051 510 -T
RJ 45 interface cable on M12	PM 051 726 -T
Accessories package for HPU	PM 061 005 -T
USB RS-485 converter	PM 061 207 -T
Interface cable, M12 m straight/M12 m straight	PM 061 283 -T
Interface cable, M12 m straight/M12 m angled	PM 061 791 -T
DCU 002, Display Control Unit	PM 061 348 -T
TCS 11, adapter for TC 110/120	PM 061 636 -U
Temperature sensor, PT100	PP 200 090 -T
Extension cable package 3 m	PP 100 304 -T
Extension cable package 5 m	PP 100 306 -T
Extension cable package 10 m	PP 100 311 -T

Accessories	Order number
Process accessories	
Sealing Gas Kit (Plastic Tube)	PP 100 091 -T
Gear Box Evacuation (Plastic Tube)	PP 100 092 -T
Spray Lance G1/2"	PM 042 765 -U
Operating fluids	
P3, mineral oil, 0.5 l	PK 001 136 -T
P3, mineral oil, 1 l	PK 001 106 -T
P3, mineral oil, 5 l	PK 001 107 -T
P3, mineral oil, 20 l	PK 001 108 -T
D1, 1L	PK 005 875 -T
D1, 5 L	PK 005 876 -T
D1, 20 L	PK 005 877 -T

Accessories for HiLobe 1302 – 2104

Accessories	Order number
Components/Seals	
Splinter Shield, DN 100 ISO-F and DN 100 ISO-K	PP 030 149 AX
Splinter shield, DN 100 PN16	PP 042 350 -X

Accessories for HiLobe 4504 – 6204

Accessories	Order number
Components/Seals	
Splinter Shield, DN 160 ISO-F	PP 031 114 -X
Splinter shield, DN 150 PN16	PP 031 115 -X

For more accessories, go to www.pfeiffer-vacuum.com

VACUUM SOLUTIONS FROM A SINGLE SOURCE

Pfeiffer Vacuum stands for innovative and custom vacuum solutions worldwide, technological perfection, competent advice and reliable service.

COMPLETE RANGE OF PRODUCTS

From a single component to complex systems:

We are the only supplier of vacuum technology that provides a complete product portfolio.

COMPETENCE IN THEORY AND PRACTICE

Benefit from our know-how and our portfolio of training opportunities!

We support you with your plant layout and provide first-class on-site service worldwide.

Are you looking for a
perfect vacuum solution?
Please contact us:

Pfeiffer Vacuum GmbH
Germany
T +49 6441 802-0

www.pfeiffer-vacuum.com



Follow us on social media
#pfeiffervacuum

PFEIFFER  **VACUUM**