

A2F Fixed Displacement pump/ motor (1~5 Serier)



Descriptics:

Axial tapered piston unit of bent axis design with fixed displacement, for use as either pump or motor in hydrostatic drives, in open or closed circuit system. When operated as a pump, the flow is proportional to the drive speed and the displacement. When operated as motor, the output speed is proportional to the flow and inversely proportional to the displacement. The output torque increases with the pressure drop between the high and low pressure sides.

Character:

Self-centering spherical control area allows torque free cylinder bearing.
Low peripheral speed and high efficiency.
Drive shaft capable of accepting radial loading.
Low noise level.

A2F Series 1~4 (Size 10~225) Section

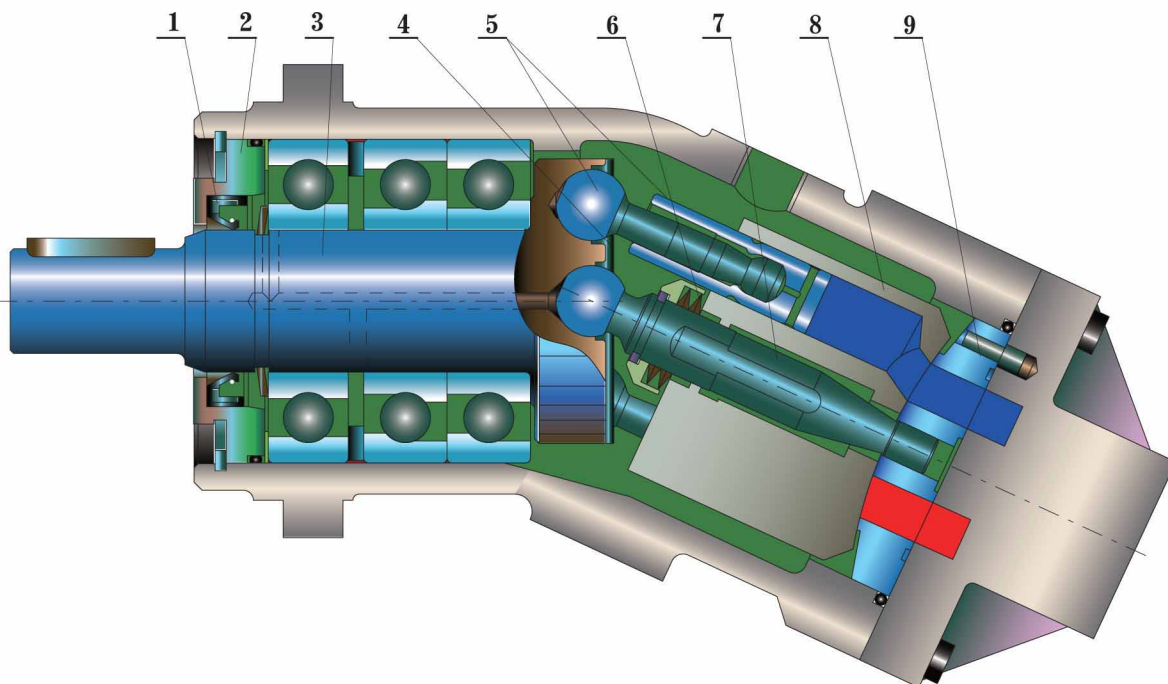

Type Code

A2F 55 R 2 P 1

Type		Rear cover	
Fixed displacement pump/motor	A2F	Port plate	1
Displacement(Vgmin~Vgmax)		Port plate	2
(9.6ml/r)	10	Port plate	3
(11.6ml/r)	12	Port plate	4
(22.7ml/r)	23	Port plate	5
(28.1ml/r)	28	Port plate	6
(44.3ml/r)	45	Port plate	7
(54.8ml/r)	55		
(63.0ml/r)	63		
(80.0ml/r)	80		
(107ml/r)	107		
(125ml/r)	125		
(160ml/r)	160		
(200ml/r)	200		
(225ml/r)	225		
(250ml/r)	250		
(355ml/r)	355		
(500ml/r)	500		
Direction of Rotation		Shaft End	
(viewed on drive shaft)		keyed shaft	GB1096-79 P
Clockwise	R	splined shaft	DIN5480 Z
Anti-clockwise	L	splined shaft	GB3478.1-83 S
Alternation (not for pumps in open circuit)	W	Series	
		Series 1	1
		Series 2	2
		Series 3	Size 10~160
		Series 4	
		Series 5	Size 200~500

Ordering Example:

A2F、55、R、2、P、1

Fixed displacement pump A2F, Size 55,
clockwise rotation, series 2, keyed shaft, port plate 1.

A2F Series 5(Size 200~500) Section

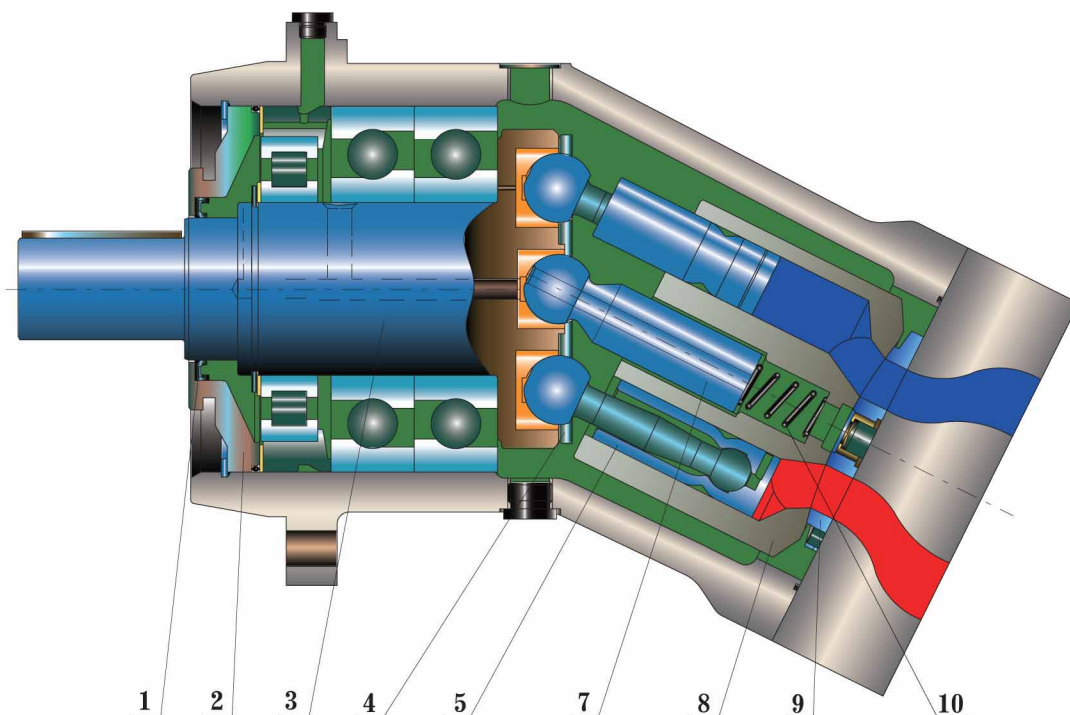

1.	Oil Seal Kit	6.	Wash Spring
2.	Front cover	7.	Center pin
3.	Shaft	8.	Cylinder Block
4.	Retainer Plate	9.	Port Plate
5.	Pistion	10.	Spring

NOTE:

To help ensure its longevity, please be careful to:

1. Keep the operating fluid clean anywhere.
2. Change the hydraulic fluid periodically (Operation 1000~3000 hours or six months).

Technical Data:

- Inlet Operating Pressure:
 - pump:
 - Minimum pressure at ports S, A or B: Pabs _____ 0.08MPa
 - In close circuits, the pressure must be between 0.2MPa and 0.6 MPa, depending on pump speed and viscosity of hydraulic fluid.
 - Motor:
 - Pressure at ports A or B:
 - Nominal pressure _____ Pn=35MPa
 - Peak pressure _____ Pmax=40MPa
 - The sum of the pressure at ports A and B must not exceed 70MPa (individual pressure on either side max.40MPa)
- Outlet Operating Pressure:
 - pump:
 - Nominal pressure _____ Pn=35MPa
 - Peak pressure _____ Pmax=40MPa
- Maximum permissible case pressure(at port T):
 - Pabs _____ 0.2MPa
- Fluid Temperature Range: -25~80°C
- Viscosity Range:
 - tmin _____ 10mm²/s
 - tmax _____ (for short periods)1000 mm²/s
 - Optimum Operating Viscosity: _____ 16~25 mm²/s
 - Fluid Recommendation: 40 low-solidifying
- Filtration of Hydraulic Fluid:
 - Recommended filtration 10 μm. Coarser filtration of 25 to 40 μm is acceptable, However longer service life is achieved.
- Speed Range:
 - No limitation on minimum speed.
 - If high uniformity of rotation is required, n_{min} should not be less than 50r/min. See table on page 5 for maximum speed.
- Mounting position:
 - Arbitrarily Choose. The housing must be filled with oil;
- Flow Direction
 - Clockwise: Anticlockwise
 - A to B B to A
 - S to B (Open Circuit) S to A (Open Circuit)

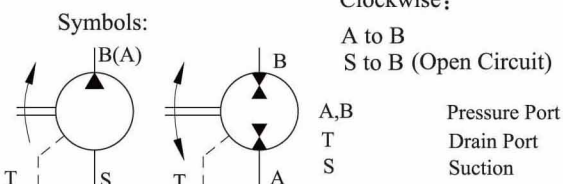

● Calculation of Size:

● pump:

Output Flow $Q = \frac{V_g \times n \times \eta_v}{1000}$ [l/min]

Input Torque $M = 0.159 \times V_g \times \Delta P / \eta_m$ [N·m]

Input Power $P = \frac{Q \times \Delta P}{60 \times \eta_t}$ [Kw]

● Motor:

Input Flow $Q = \frac{V_g \times n}{1000 \times \eta_v}$ [l/min]

Output Speed $n = \frac{Q \times 1000 \times \eta_v}{V_g}$ [r/min]

Output Torque $M = 0.159 \times V_g \times \Delta P \times \eta_m$ [N·m]

Output Power $P = \frac{Q \times \Delta P \times \eta_t}{60}$ [Kw]

- V_g = max geometric displacement [ml/r]
- M = torque [N·m]
- ΔP = differential pressure [MPa]
- n = speed [r/min]
- η_v = volumetric efficiency
- η_m = mechanical-hydraulic efficiency
- η_t = overall efficiency

Rear cover:

(Size)	10~160	200~500
1. A,B Thread		6. A,B Flange
2. A,B Flange		7. A,B Flange
3. A,B Flange		5. B,S Prick Worm
4. B,S Thread		2. B,S Flange

Used for close system pump / motor

Used for open system pump

A2F Fixed Displacement pump/ motor (1~5 Series)

Technical Data Theoretical Values, Without Considering η_m and η_v . Values rounded Off.

Size		10	12	23	28	45	55	63	80	107	125	160	200	250	355	500	
Displacement V_g (ml/r)		9.4	11.6	22.7	28.1	44.3	54.8	63	80	107	125	160	200	250	355	500	
Max.Speed n max(r/min)	Close Circuit	7500	6000	5600	4750	4500	3750	4000	3350	3000	3150	3650	2500	2500	2240	2000	
	Open Circuit, Inlet Pressure	0.09	4700	3750	3750	2800	2850	2360	2550	2120	1900	2120	1650	1700	1400	1250	1120
	(Pabs=MPa)	0.10	5000	4000	4000	3000	3000	2500	2700	2240	2000	2240	1750	1800	1500	1320	1200
Max.Flow Q max(l/min)	Close Circuit	0.15	6000	4900	4900	3600	3550	3000	3300	2750	2450	2750	2100	2180	1850	1650	1500
	Open Circuit, Inlet Pressure	71	70	127	133	199	206	252	268	321	394	424	500	625	795	1000	
	(Pabs=MPa)	0.09	43	42	83	76	122	125	156	165	197	257	256	330	340	430	543
Max.Power P_{max} (Kw) $\Delta P=35$ MPa	Close Circuit	0.10	46	45	88	82	129	133	165	174	208	272	272	349	364	455	582
	Open Circuit	0.15	55	55	108	98	157	159	202	213	254	333	326	423	449	568	728
	Inlet Pressure (Pabs=MPa)	41	41	74	78	116	120	147	156	187	230	247	292	365	454	583	
Electric Motor Speed $n=1450$ /min	Flow Q (l/min)	0.09	25	25	48	44	71	73	91	96	115	150	149	192	198	251	317
	Close $\Delta P=35$ MPa	0.10	27	26	51	48	75	78	96	101	121	159	159	204	212	265	340
	Open	0.15	32	32	63	57	92	93	118	124	148	194	190	247	262	331	424
Torque(N·m)	Flow Q (l/min)	13.6	16.8	32.9	40.7	64.2	79.5	91.3	116	155.2	181.2	232	290	363	515	725	
	Open Circuit	13.2	16.3	31.9	39.5	62.3	77.1	88.6	112.5	150.5	175.8	225	281	352	499	703	
Torque(N·m)	P(Kw)	7.9	9.8	19.2	23.7	37.4	46	53	67.7	90	106	135	169	212	300	423	
	Close $\Delta P=35$ MPa	7.7	9.5	18.6	23	36.3	45	51.7	66	88	103	131	169	212	300	423	
Torque(N·m)	$\Delta P=10$ MPa	15	18	36	44.7	70	87	100	127	170	199	254	318	398	564	795	
	$\Delta P=35$ MPa	52	65	126	156	247	305	351	445	595	696	890	1113	1391	1976	2783	
Approx.Weight (kg)		5	5	12	12	23	23	33	33	44	63	63	88	88	138	185	

Notes:

1. These values are valid provided there is a absolute pressure at suction inlet S and when operated on mineral oil.

Nomograph

Permissible speed n_{perm} can be determined from the nomograph. In motor operation the permissible speed for closed circuit system and boosted operation are also valid for open circuit system. When suction pressure $P_{abs} > 0.1$ MPa, the permissible speed can be increased in open circuits (Self-suction operation). But when suction pressure $p_{abs} < 0.1$ MPa, the permissible speed must be reduced.

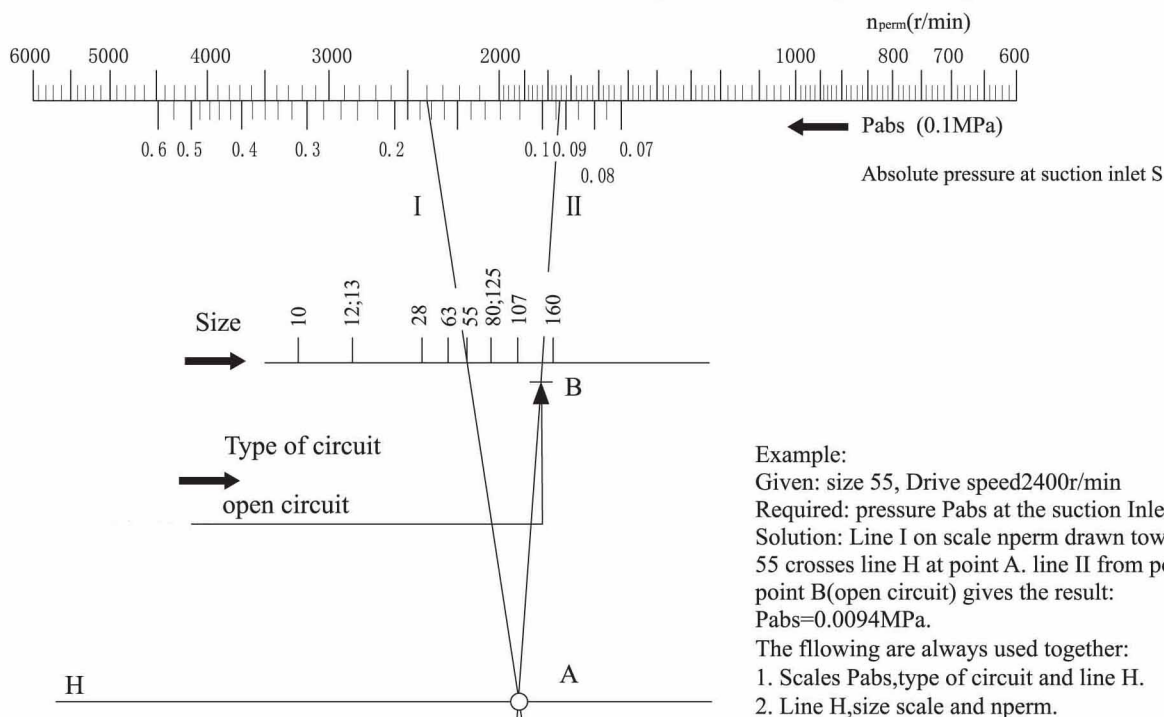

Series 1,3,4

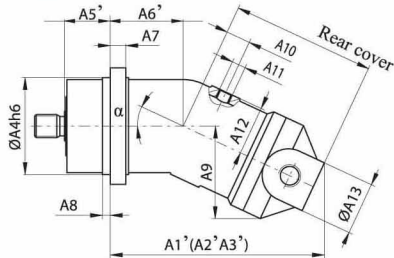

Series 2

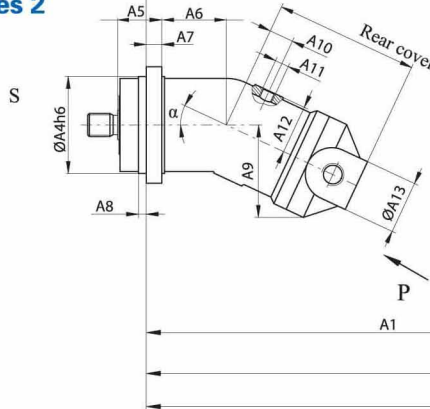

Rear cover

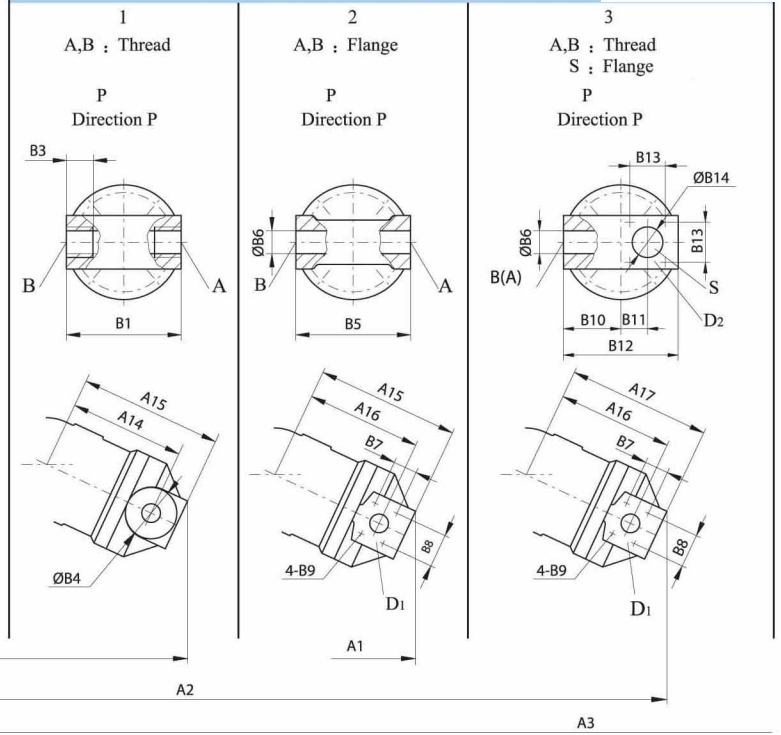

Note:

1. The dimensions of A1, A2, A3 are only valid for series 2. The parallel dimensions of the three above mentioned positions for series 1,3 and 4 can be calculated according to the follows formulas: $A1'-(A6-A6')$; $A2-(A6-A6')$; $A3-(A6-A6')$.
2. Besides above mentioned constructs, we can adjust the design of the present product according to the customers' special needs.

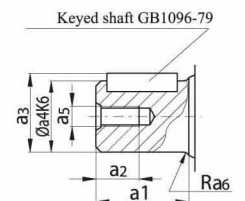

Unit Dimensions Series 1~4 size 10~160

Size		Series	Rear cover	A1		A2		A3		A4	A5	A6	A5'	A6'	A7	A8	A9	
α20°	α25°			α20°	α25°	α20°	α25°	α20°	α25°								α20°	α25°
10	12	2,4	1,4	174	172	-	-	-	-	80	20	62	40	42	12.5	8	69	75
23	28	2,3	1,2,4	223	218	-	-	-	-	100	25	75	50	50	16	8	88	95
45	55	1,2	1,2,3,6	292	289	286	284	-	-	125	32	108	63	77	20	10	110	118
63	80	1,2	1,2,3	350	348	345	342	-	-	140	32	137	83	86	23	10	126	140
87	107	1,2	1,2,3,7	360	356	353	348	358	353	160	40	130	80	90	25	12	138	149
125	160	2	1,2,3,7	422	417	417	410	408	420	180	40	156	-	-	28	10	159	173.5

Size		A10	A11	A12	A13	A14	A15	A16	A17	A18		A19	A20	B1	B2	B3	B4
α20°	α25°									α20°	α25°						
10	12	14	M12×1.5	40	89	90	112	-	-	-	-	-	-	89	M22×1.5	14	34
23	28	25	M16×1.5	50	106	118	145	118	-	-	-	-	-	106	M27×2	16	48
45	55	31.5	M18×1.5	63	132	151	183	151	178	-	-	-	-	132	M33×2	15	53
63	80	36	M18×1.5	77	156	174	213	174	208	-	-	-	-	156	M42×2	20	72
87	107	40	M18×1.5	80	165	230	230	190	225	185	200	230	195	160	M42×2	20	50
125	160	45	M22×1.5	93	195	162	262	212	257	204	220	252	212	195	M48×2	22	70

Size		B5	B6	B7	B8	B9	Deep	B10	B11	B12	B13	B14	B15	Deep	B16	Deep	B17	B18	B19	B20
α20°	α25°																			
10	12	-	-	-	-	-	-	44.5	18	-	-	-	-	-	M33×2	18	42	-	-	-
23	28	120	13	18.2	40.5	M8	15	53	25	-	-	-	-	M42×2	20	48	-	-	-	
45	55	126	19	23.8	50.8	M10	15	63	29	129	48	42	M10	13	-	-	-	67	20	-
63	80	150	25	27.8	57.2	M12	15	75	35.5	153	60	53	M12	15	-	-	-	-	-	
87	107	160	25	27.8	57.2	M12	17	80	35.5	162.5	60	53	M12	18	-	-	-	-	25	
125	160	190	32	31.8	66.7	M14	19	95	42.2	192.5	75	68	M16	20	-	-	-	-	39	

Size		B21	Deep	B22	B23	C1	C2	C3	C4	a1	a2	a3	a4	a5	a6	a7	a8	a9	a10
α20°	α25°																		
10	12	-	-	-	-	95	100	10	9	40	16	22.5	20	M6	0.8	34	2	22	16.7
23	28	-	-	-	-	118	125	12	11	50	19	27.9	25	M8	0.8	43	1.2	28	21.5
45	55	-	-	-	-	150	160	16	13.5	60	28	33	30	M12	1.5	35	1.5	28	25
63	80	-	-	-	-	165	180	16	13.5	70	28	38	35	M12	1.6	40	1.5	33	30
87	107	M12	25	50	78	190	200	20	17.5	80	28	43	40	M12	1.6	45	2	37.5	35
125	160	M12	25	50	78	210	224	20	17.5	90	36	48.5	45	M16	2.5	50	2.5	43	40

Size		SAE SAE Flang		Parallel	Splined Shaft	Splined Shaft	Weight (kg)
α20°	α25°	D1	D2	GB1096-79	DIN5480	GB3478- 83	
10	12	-	-	Key6×32	W20×1.25×14×9g	-	5
23	28	1/2"	1/2"	Key8×40	W25×1.25×18×9g	-	12
45	55	3/4"	1 3/4"	Key8×50	W30×2×14×9g	-	23
63	80	1"	2"	Key10×56	W35×2×16×9g	EXT16Z×2m×30R×5f	33
87	107	1"	2"	Key12×63	W40×2×18×9g	EXT18Z×2m×30R×5f	44
125	160	1 1/4"	2 3/4"	Key14×70	W45×2×21×9g	-	210

Unit Dimensions Series 5

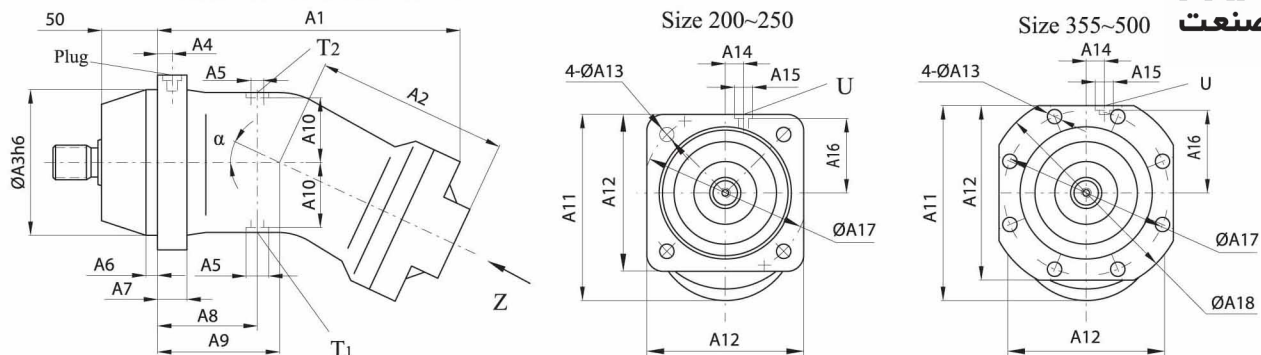

shaft end

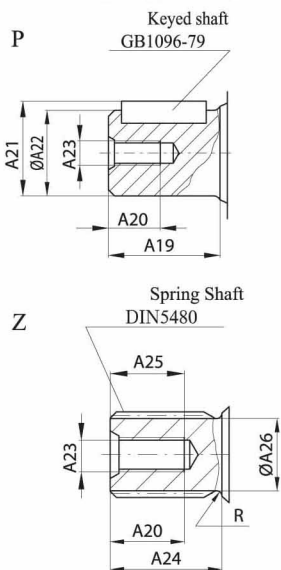

End Plate(Direction Z)

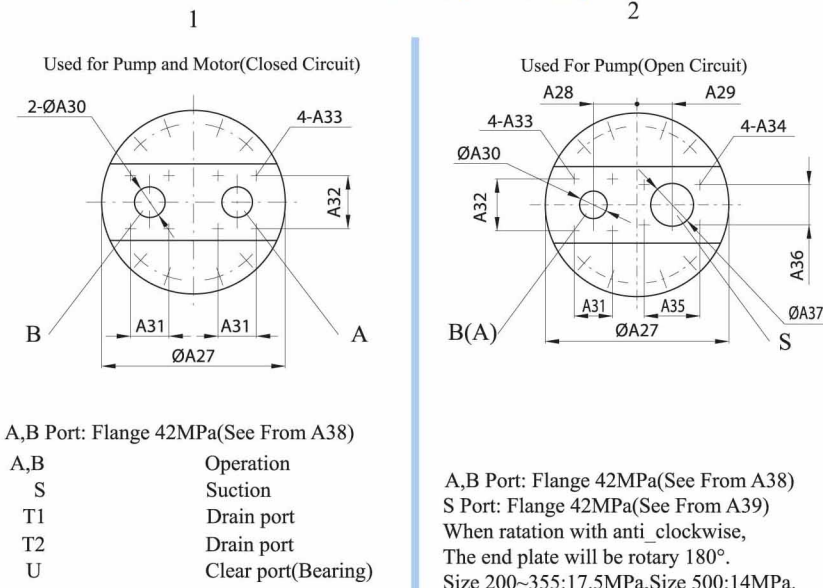

Series 5 Size 200~500 Table Of Unit Dimensions

Size	α	A1	A2	A3	A4	A5	A6	A7	A8	A9	A10	A11	A12	AB	A14	A15
200	21°	368	232	224	13	M22×1.5	9	25	120	134	107	300	252	22	70	M14×1.5
250	26.5°	370	232	224	13	M22×1.5	9	25	120	134	107	314	252	22	70	M14×1.5
355	26.5°	422	260	280	14	M33×2	15	28	142	160	128	380	335	18	35	M14×1.5
500	26.5°	462	283	315	15	M33×2	15	30	155	175	142	420	375	22	35	M18×1.5

Size	A16	A17	A18	A19	A20	A21	A22	A23	A24	A25	A26	A27	A28	A29	A30	A31	A32	A33
200	122	280	/	82	36	53.5	50	M16	58	47	45	216	55	45	32	31.8	66.7	M14
250	122	280	/	82	36	53.5	50	M16	58	47	45	216	55	45	32	31.8	66.7	M14
355	166	320	360	105	42	64	60	M20	82	69	55	245	60	50	40	36.6	79.4	M16
500	180	360	400	105	42	74.5	70	M20	82	67	62.5	270	65	55	40	36.5	79.4	M16

Size	Deep	A34	Deep	R	A35	A36	A37	A38	A39	Parallel GB1096-79	Spline DIN5480	Weight (kg)
200	22	M12	18	1.2	88.9	50.8	63	1 1/4"	2 1/2"	Key14×80	W50×2×24×9g	88
250	22	M12	18	1.2	88.9	50.8	63	1 1/4"	2 1/2"	Key14×80	W50×2×24×9g	88
355	24	M12	18	1.6	88.9	50.8	63	1 1/2"	2 1/2"	Key18×100	W60×2×28×9g	138
500	24	M16	24	1.6	106.4	62	75	1 1/2"	3"	Key20×100	W70×2×22×9g	185

A2F6.1 Fixed Displacement Pump/Motor Section



Descriptics:

A2F6.1 series is taper piston design, fixed displacement. It is widely use for open and closed circuit as pump or motor in hydrostatic drive.

When operated as a pump, the flow is proportional to the drive speed and the displacement.

When operated as motor, the output speed is proportional to the flow and inversely proportional to the displacement.

Character:

Housing angle is 40°. compare with A2F 1~4 series. Displacement increase 52%, torque increase 70%, so power/weight high efficiency, and unit dimensions smaller.

Weight lighter than A2F 1~4 series.

NOTE:

To help ensure its longevity, please be careful to:

1. Keep the operating fluid clean anywhere.
2. Change the hydraulic fluid periodically (Operation 1000~3000 hours or six months).

A2F6.1 Fixed Displacement Pump/Motor Section

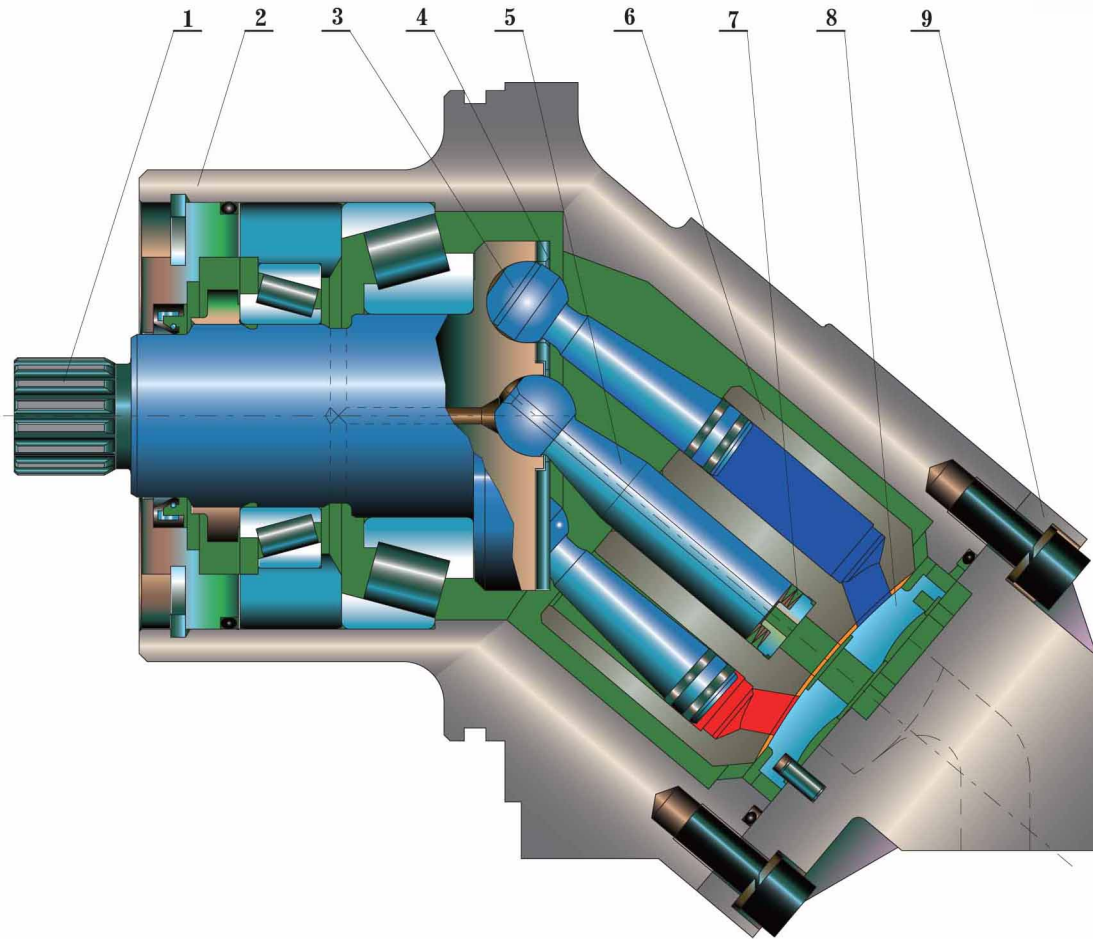

- | | |
|-------------------|-------------------|
| 1. Shaft | 6. Cylinder Block |
| 2. Shell | 7. Wash Spring |
| 3. Pistion | 8. Port Plate |
| 4. Retainer Plate | 9. End Cover |
| 5. Center pin | |

A2F6.1 Fixed Displacement Pump/Motor Section

Type Code:

A2F 90 W 6.1 Z 2

Motor Type		Fixed displacement pump/motor		A2F
Size		Displacement(Vgmin~Vgmax)		90
Direction of Rotation		(viewed on drive shaft)		W
Clockwise				R
Anti-clockwise				L
Alternation (only used for motor)				W
Revised Series		Standard Series		
12		16		
23		32		
28		45		
56		63		
80		90		
107		125		
160		180		
End plates		used for motor/pump(close circuit)		2
		used for pump(open circuit)		6
Shaft End		(viewed unit dimensions)		
splined shaft DIN5480		Z	A	
keyed shaft GB1096-79		P	B	
Series		Series		6.1

A2F , 90, W, 6.1, Z, 2
A2F , 90
6.1

Ordering Example:

A2F , 90, W, 6.1, Z, 2

Fixed displacement motor A2F, Size 90,

Alternation rotation, series 6.1, Splined shaft, End plate 2.

Technical Data:

● Calculation of Size:

● pump:

Output Flow $Q = \frac{V_g \times n \times \eta_v}{1000}$ [l/min]

Input Torque $M = 0.159 \times V_g \times \Delta P / \eta_{mh}$ [N·m]

Input Power $P = \frac{Q \times \Delta P}{60 \times \eta_t}$ [Kw]

V_g = max geometric displacement [ml/r]
 M = torque [N·m]
 ΔP = differential pressure [MPa]
 n = speed [r/min]

● Motor:

Input Flow $Q = \frac{V_g \times n}{1000 \times \eta_v}$ [l/min]

Output Speed $n = \frac{Q \times 1000 \times \eta_v}{V_g}$ [r/min]

Output Torque $M = 0.159 \times V_g \times \Delta P \times \eta_{mh}$ [N·m]

Output Power $P = \frac{Q \times \Delta P \times \eta_t}{60}$ [Kw]

η_v = volumetric efficiency
 η_{mh} = mechanical-hydraulic efficiency
 η_t = overall efficiency

Standard

● Inlet Operating Pressure:

● pump:

Minimum pressure at ports S, A or B:

Pabs _____ 0.08MPa

In close circuits, the pressure must be between 0.2MPa and 0.6 MPa, depending on pump speed and viscosity of hydraulic fluid.

● Motor:

Pressure at ports A or B:

Shaft end A Splined shaft DIN5480

Nominal pressure _____ Pn=40MPa

Peak pressure _____ Pmax=45MPa

Shaft end B Keyed shaft GB1096-79

Nominal pressure _____ Pn=35MPa

Peak pressure _____ Pmax=40MPa

- Outlet Operating Pressure:
- Pump: Pressure at ports A or B
Shaft end A Splined shaft DIN5480
Nominal pressure——— Pn=40MPa
Peak pressure——— Pmax=45MPa
Shaft end B Keyed shaft GB1096-79
Nominal pressure——— Pn=35MPa
Peak pressure——— Pmax=40MPa

Adaptation

- Inlet Operating Pressure:
- Pump: Minimum pressure at ports S、A or B
Pabs ——— 0.08MPa
In close circuits, the pressure must be between 0.2MPa and 0.6 MPa, depending on pump speed and viscosity of hydraulic fluid.
- Motor: Pressure at ports A or B
Shaft end Z Splined shaft DIN5480
Nominal pressure——— Pn=35MPa
Peak pressure——— Pmax=40MPa
Shaft end P Keyed shaft GB1096-79
Nominal pressure——— Pn=35MPa
Peak pressure——— Pmax=40MPa
- Outlet Operating Pressure:
- Pump: Pressure at ports A or B
Shaft end Z Splined shaft DIN5480
Nominal pressure——— Pn=35MPa
Peak pressure——— Pmax=40MPa
Shaft end P Keyed shaft GB1096-79
Nominal pressure——— Pn=35MPa
Peak pressure——— Pmax=40MPa

- Maximum permissible case pressure(at port T):
Pabs ——— 1MPa
- Fluid Temperature Range: -25~80°C
- Viscosity Range:
tmin ——— 10mm²/s
tmax ——— (for short periods)1000 mm²/s
Optimum Operating Viscosity:——— 16~25 mm²/s
Fluid Recommendation: 40 low-solidifying
- Recommended filtration: 10μm.
Coarser filtration of 25~40μm is acceptable, but with filtration of 10μm longer service life is obtained (reduced wear).
- Speed Range:
No limitation on minimum speed;
If high uniformity of rotation is required, n_{min} should not be less than 50r/min. See table on page 5 for maximum speed.

● Mounting position:

Arbitrarily Choose. The housing must be filled with oil;

● Flow Direction

Clockwise: Anticlockwise:
A to B B to A
S to B S to A

(Open Circuit) (Open Circuit)

● Symbols:

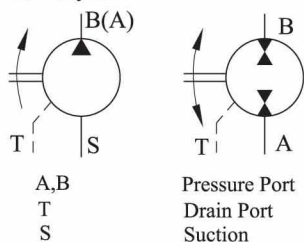

● Nomograph

Permissible speed n_{perm} can be determined from the nomograph.

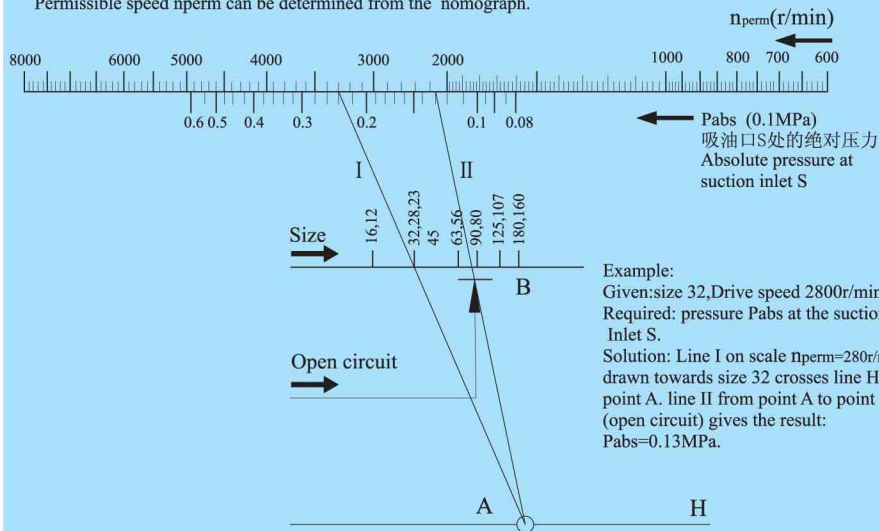

A, B
T
S

Pressure Port
Drain Port
Suction

A2F6.1 Fixed Displacement Pump/Motor Section

Technical Data Theoretical Values, Without Considering η_m and η_v , Values rounded Off.
Standard:

Size				16	32	45	63	90	125	180	
output(In put) Displacement		Vg	ml/r	16.0	32.0	45.6	63.0	90.0	125.0	180.0	
Max.speed	Closed circuit	n _{max}	r/min	6000	4750	4250	3750	3350	3000	2650	
	Open circuit	0.09MPa ①	n _{o0.09} r/min	2980	2370	2120	1890	1705	1515	1375	
		0.10MPa ①	n _{o0.10} r/min	3150	2500	2240	2000	1800	1600	1450	
		0.15MPa ①	n _{o0.15} r/min	3760	2985	2670	2390	2150	1910	1730	
Max.output (Input)flow	Closed circuit	Q _{max}	l/min	96	152	194	236	302	375	477	
	Open circuit	n _{o0.09} ②	n _{o0.09} l/min	47	74	95	117	150	186	243	
		n _{o0.10} ②	n _{o0.10} l/min	49	78	100	123	159	196	256	
		n _{o0.15} ②	n _{o0.15} l/min	59	94	119	148	190	243	305	
Max.power ΔP=40MPa (Splined shaft end)	Closed circuit	Q _{max}	P _{max} kW	64	101	129	157	201	250	318	
	Open circuit	Q _{o0.09}	P _{o0.09} kW	32	51	65	79	102	126	165	
		Q _{o0.10}	P _{o0.10} kW	33	53	68	84	108	133	174	
		Q _{o0.15}	P _{o0.15} kW	40	64	81	101	129	159	207	
Max.Power ΔP=35MPa (Keyed shaft end)	Closed circuit	Q _{max}	P _{max} kW	56	89	113	138	176	219	278	
	Open circuit	Q _{o0.09}	P _{o0.09} kW	28	44	57	69	89	110	145	
		Q _{o0.10}	P _{o0.10} kW	29	17	60	74	95	117	152	
		Q _{o0.15}	P _{o0.15} kW	35	56	71	88	113	139	182	
Drive speed n _e =1450r/min	Output(Input) Flow	Closed	Q	l/min	23	46	66	91	130	181	261
		Open ②	Q	l/min	22.7	45	65	90	128	178	256
	Power ΔP=40MPa ΔP=35MPa	closed+open	P	kW	15	31	44	61	87	121	174
			P	kW	13	26	38	53	75	104	149
Torque	ΔP=10MPa	M	N.m	25.4	50.9	72.5	100.2	143.1	198.8	286.2	
	ΔP=40MPa	M _{max}	N.m	101.8	203.5	290	400.7	572.4	795	1144.8	
	ΔP=35MPa	M _{max}	N.m	89	178	253.8	350.6	500.9	695.6	1001.7	
Moment of Inertia about drive axis		J	kgm ²	0.0004	0.0012	0.0024	0.0042	0.0072	0.0116	0.022	
Weight		m	kg	6	9.5	13.5	18	23	32	45	

Adaptation:

Size				12	23	28	56	80	107	160
Output(Input) Displacement		Vg	ml/r	12.0	22.9	28.1	56.1	80.4	106.7	160.4
Max.speed	close circuit	n _{max}	r/min	6000	4750	4750	3750	3350	3000	2650
	Open circuit	0.09MPa ①	n _{o0.09} r/min	2980	2370	2370	1890	1705	1515	1375
		0.10MPa ①	n _{o0.10} r/min	3150	2500	2500	2000	1800	1600	1450
		0.15MPa ①	n _{o0.15} r/min	3760	2985	2985	2390	2150	1910	1730
Max.Output (Input) Flow	close circuit	Q _{max}	l/min	72	109	133	210	269	320	425
	Open circuit	n _{o0.09} ②	P _{o0.09} l/min	35	53	65	104	134	158	216
		n _{o0.10} ②	P _{o0.10} l/min	37	56	69	110	142	167	228
		n _{o0.15} ②	P _{o0.15} l/min	44	67	82	131	169	200	272
Max.Power ΔP=35MPa	close circuit	Q _{max}	P _{max} kW	42	64	78	123	157	187	248
	Open circuit	Q _{o0.09}	P _{o0.09} kW	21	32	39	62	80	94	129
		Q _{o0.10}	P _{o0.10} kW	22	33	41	65	85	99	136
		Q _{o0.15}	P _{o0.15} kW	26	40	49	78	101	119	162
Drive speed n _e =1450r/min	Output(Input)Flow	close	Q	l/min	17	33	41	81	117	233
		open ②	Q	l/min	17	33	40	80	114	228
	owerΔP=35MPa	close+open	P	kW	10	19	24	47	68	90
Torque	ΔP=10MPa	M	N·m	19	36	45	89	128	170	255
	ΔP=35MPa	M _{max}	N·m	67	127	156	312	447	594	893
Moment of Inertia about Drive axis		J	kgm ²	0.0004	0.0012	0.0012	0.0042	0.0072	0.0116	0.0220
Weight		m	kg	6	9.5	9.5	18	23	32	45

Notes:

① The values given are valid for absolute pressure at suction inlet S and for operation on mineral oils.

② Calculated at 2% volumetric loss.

Unit Dimensions

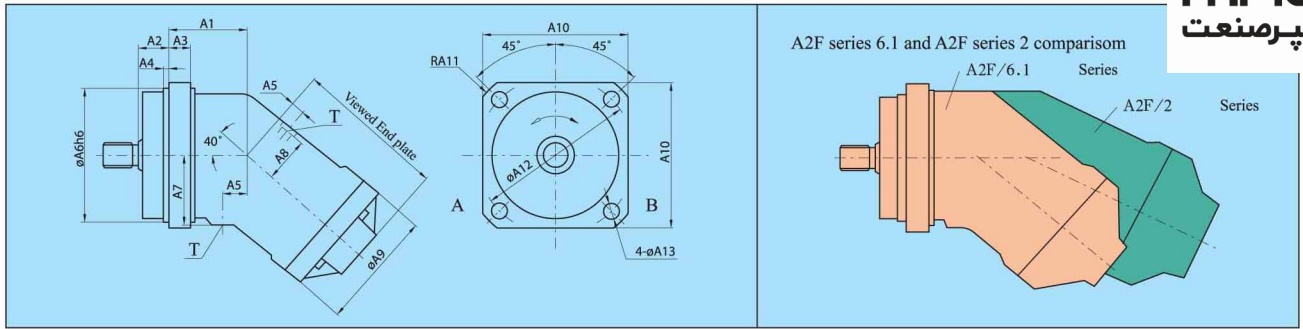

End plates 1~4 are used for motor and pump(closed circuit)

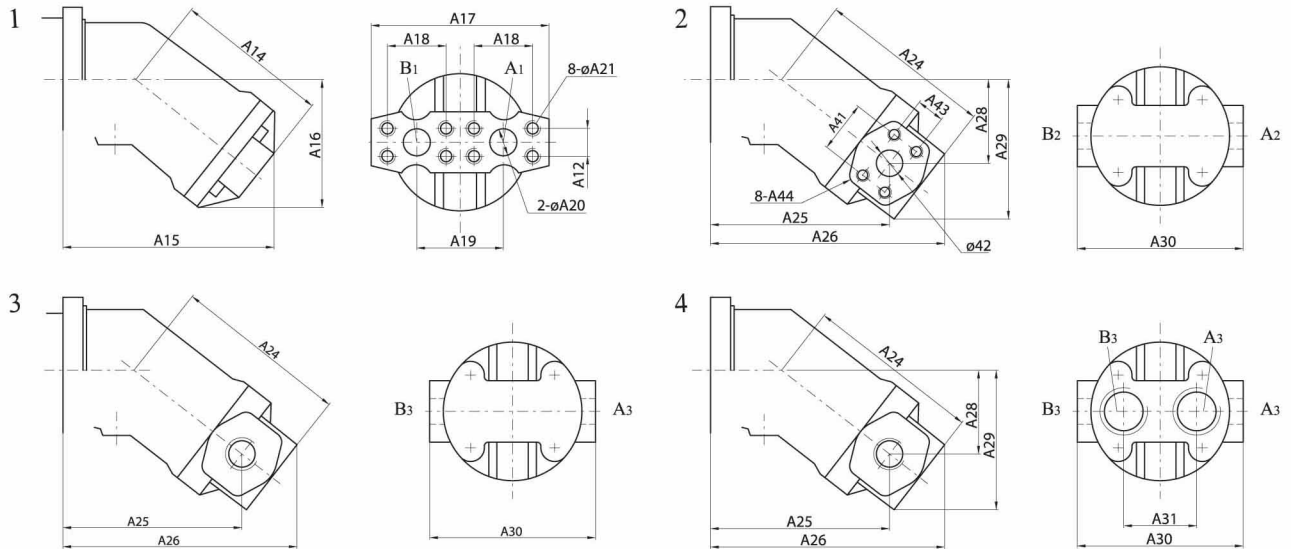

End plates 5、6 are used for pump(open circuit).Graph is clockwise rotation.
for anti-clockwise,end plates 5、6 are rotation 180°.

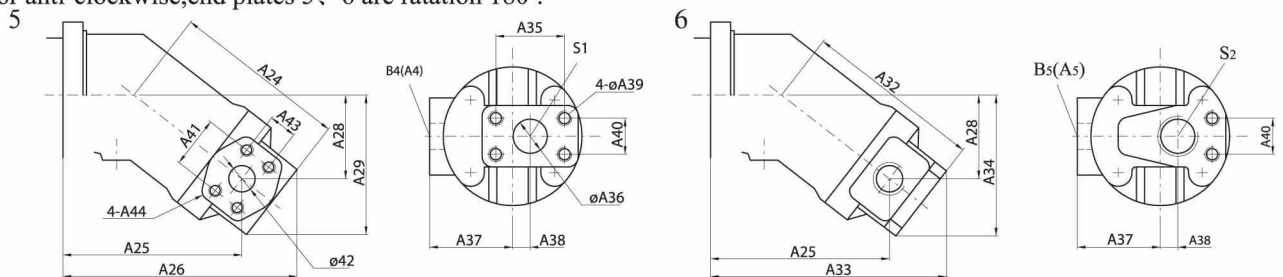

Shaft end

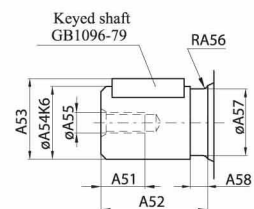
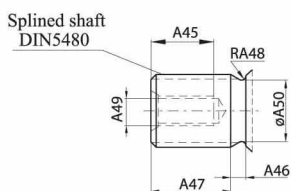

splined shaft A Nomined pressure $P_n=40\text{MPa}$, Peak pressure $P_{max}=45\text{MPa}$;
Z Nomined pressure $P_n=35\text{MPa}$, Peak pressure $P_{max}=40\text{MPa}$;

Keyed shaft B Nomined pressure $P_n=35\text{MPa}$, Peak pressure $P_{max}=40\text{MPa}$;
P Nomined pressure $P_n=35\text{MPa}$, Peak pressure $P_{max}=40\text{MPa}$;

A2F6.1 Fixed Displacement Pump/Motor Section

Unit Dimensions

size		End plate	size													
standard series	revised series		A1	A2	A3	A4	A5	A6	A7	A8	A9	A10	A11	A12	A13	A14
16	12	-- 3,4 - 6	64.5	20	12	6	5	80	53.5	41.5	85	95	10	100	9	-
32	23;28	1,2,3,4,5,6	60.7	25	18	8	19	100	55.5	48.5	106	118	12	125	11	121
45		1,2,3,4,5,-	60.3	32	20	12	18	125	63	52	118	150	16	160	13.5	138
63	56	1,2,3,4,5,-	67.5	32	20	10	18	125	70	56	128	150	16	160	13.5	149.5
90	80	1,2,3,4,5,-	78.5	32	20	10	15	140	83	61	138	165	16	180	13.5	162.5
125	107	1,2,3,4,5,-	82.8	40	23	10	18	160	85	67	150	190	20	200	17.5	186.5
180	160	1,2,3,4,5,-	93	40	25	10	19.5	180	95.5	77.5	180	210	20	224	17.5	208

size		End plate	size													
standard series	revised series		A15	A16	A17	A18	A19	A20	A21	A22	A23	A24	A25	A26	A27	
16	12	-- 3,4 - 6	-	-	-	-	-	-	-	-	-	108	130.5	159.5	-	
32	23;28	1,2,3,4,5,6	173	106	115	40.5	59	13	M8 _{deep} 15	18.2	-	137	144	190	-	
45		1,2,3,4,5,-	187	119	147	50.8	75	19	M10 _{deep} 17	23.8	-	155	155	207	-	
63	56	1,2,3,4,5,-	206	130	147	50.8	75	19	M10 _{deep} 17	23.8	-	166.5	171	225	-	
90	80	1,2,3,4,5,-	233	145	166	57.2	84	25	M12 _{deep} 17	27.8	-	189.5	196	257	-	
125	107	1,2,3,4,5,-	252	159	194	66.7	99	32	M14 _{deep} 19	31.8	-	-	213	-	-	
180	160	1,2,3,4,5,-	294	188	194	66.7	99	32	M14 _{deep} 19	31.8	-	233	237	294	-	

size		End plate	size													
standard series	revised series		A28	A29	A30	A31	A32	A33	A34	A35	A36	A37	A38	A39	A40	
16	12	- 3,4 - 6	55.5	85	85	36	108	167.5	93.5	-	-	42.5	16	-	-	
32	23;28	1,2,3,4,5,6	70	117	120	58	141	193	120	47.6	19	60	14	M10 _{deep} 17	22.2	
45		1,2,3,4,5,-	80	133	128	58	155	207	133	52.4	25	63.5	20	M10 _{deep} 17	26.2	
63	56	1,2,3,4,5,-	87	142	136	58	166.5	225	142	52.4	25	68	23	M10 _{deep} 17	26.2	
90	80	1,2,3,4,5,-	99	162	160	64	189.5	225	160	58.7	32	73	25	M12 _{deep} 17	30.2	
125	107	1,2,3,4,5,-	110	181	178	71	222	275	173	69.9	38	89	20	M12 _{deep} 20	35.7	
180	160	1,2,3,4,5,-	121	188	202	71	233	294	188	69.9	38	101	15	M12 _{deep} 20	35.7	

Series	Size	A41	A42	A43	A44	A45	A46	A47	A48	A49	A50	A51	A52	A53	A54	A55	A56	A57	A58
standard series	16	-	-	-	-	22	6	28	1.6	M10	21.8	22	40	28	25	M10	1	24.6	2.5
	32	40.5	13	18.2	M8 _{deep} 15	22	8	35	1.6	M10	25	22	50	33	30	M10	0.8	-	-
	45	50.8	19	23.8	M10 _{deep} 17	28	8	35	1.6	M12	25	28	60	33	30	M12	0.8	-	-
	63	50.8	19	23.8	M10 _{deep} 17	28	8	40	1.6	M12	30	28	60	38	35	M12	1	34.5	2.5
	90	57.2	25	27.8	M12 _{deep} 17	36	8	45	2.5	M16	35	36	70	43	40	M16	1	39.6	2.5
	125	66.7	32	31.8	M14 _{deep} 19	36	8	50	2.5	M16	40	36	80	48.5	45	M16	1.6	-	-
revised series	180	66.7	32	31.8	M14 _{deep} 19	36	11	55	4	M16	45	36	90	35.5	50	M16	2.5	-	-
	12	-	-	-	-	16	12	34	1.2	M6	16.8	16	40	22.5	20	M6	1	19.6	2.5
	23	40.5	13	18.2	M8 _{deep} 15	19	15	43	1.6	M8	21.8	19	50	28	25	M8	0.8	-	-
	28	40.5	13	18.2	M8 _{deep} 15	19	15	43	1.6	M8	21.8	19	50	28	25	M8	0.8	-	-
	56	50.8	19	23.8	M10 _{deep} 17	28	8	35	1.6	M12	25	28	60	33	30	M12	1.6	-	-
	80	57.2	25	27.8	M12 _{deep} 17	28	8	40	1.6	M12	30	28	70	38	35	M12	1.6	-	-
107	57.2	25	27.8	M12 _{deep} 17	28	8	45	2.5	M12	35	28	80	43	40	M12	1.6	-	-	
160	66.7	32	31.8	M8 _{deep} 19	36	8	50	2.5	M16	40	36	90	48.5	45	M16	2.5	-	-	

Series	Size	Port								splined shaft DIN5480	parallel keyed GB1096-79
		A1B1	A2B2	A3B3	A4B4	A5,B5	S1	S2	T		
standard series	16	-	-	M22×1.5	-	M22×1.5	-	M32×2	M12×1.5	W25×1.25×18×9g	key8×32
	32	SAE1/2"	SAE1/2"	M27×2	SAE1/2"	M27×2	SAE3/4"	M42×2	M16×1.5	W30×2×14×9g	key8×40
	45	SAE3/4"	SAE3/4"	M33×2	SAE3/4"	-	SAE1"	-	M18×1.5	W30×2×14×9g	key8×50
	63	SAE3/4"	SAE3/4"	M33×2	SAE3/4"	-	SAE1"	-	M18×1.5	W35×2×16×9g	key10×50
	90	SAE1"	SAE1"	M42×2	SAE1"	-	SAE1 1/4"	-	M18×1.5	W40×2×18×9g	key12×56
	125	SAE1 1/4"	SAE1 1/4"	M48×2	SAE1 1/4"	-	SAE1 1/4"	-	M18×1.5	W45×2×24×9g	key14×63
	180	SAE1 1/4"	SAE1 1/4"	M48×2	SAE1 1/4"	-	SAE1 1/2"	-	M22×1.5	W50×2×24×9g	key14×70
revised series	12	-	-	M22×1.5	-	M22×1.5	-	M33×2	M12×1.5	W25×1.25×14×9g	key6×32
	23	SAE1/2"	SAE1/2"	M27×2	SAE1/2"	M27×2	SAE3/4"	M42×2	M16×1.5	W25×1.25×18×9g	key8×40
	28	SAE1/2"	SAE1/2"	M27×2	SAE1/2"	M27×2	SAE3/4"	M42×2	M16×1.5	W25×1.25×18×9g	key8×40
	56	SAE3/4"	SAE1/4"	M33×2	SAE3/4"	-	SAE1"	-	M18×1.5	W30×2×14×9g	key8×50
	80	SAE1"	SAE1"	M42×2	SAE1"	-	SAE1 1/4"	-	M18×1.5	W35×2×16×9g	key10×56
	107	SAE1 1/4"	SAE1"	M42×2	SAE1"	-	SAE1 1/2"	-	M18×1.5	W40×2×18×9g	key12×63
	160	SAE1 1/4"	SAE1 1/4"	M48×2	SAE1 1/4"	-	SAE1 1/2"	-	M22×1.5	W45×2×21×9g	key14×70