



GENERAL CATALOGUE

 **PEDROLLO**[®]
... the spring of life



PEDROLLO S.p.A.

Via Enrico Fermi 7

37047 San Bonifacio (Verona) ITALY

paid-up capital € 40.000.000,00

Tel. +39 045 6136311

Fax +39 045 7614663

e-mail: sales@pedrollo.com

www.pedrollo.com



PERFORMANCE RANGE

- Flow rate up to **1000 l/min** (60 m³/h)
- Head up to **390 m**

APPLICATION LIMITS

- Maximum liquid temperature **+35 °C**
- Maximum sand content **100 g/m³**
- **100 m** immersion limit
- Installation:
 - vertical
 - horizontal, with the following limits: up to **12 stages** or **11 kW**
- Starts/hour: 20 at regular intervals
- Minimum flow rate for motor cooling **16 cm/s** (0.5 m/s for 30 kW)
- Continuous service **S1**

CONSTRUCTION AND SAFETY STANDARDS

ELECTRIC MOTOR

– Three-phase 400 V - 50 Hz

4 m long power cable

EN 60034-1
IEC 60034-1
CEI 2-3



CERTIFICATIONS



INSTALLATION AND USE

Suitable for use with clean water with a sand content of no more than 100 g/m³. As a result of their high efficiency and reliability, they are suitable for use in civil, agricultural and industrial applications such as for the distribution of water in combination with pressure sets, for irrigation and for pressure boosting in fire-fighting sets, etc.

OPTIONALS AVAILABLE ON REQUEST

- 6SR-HYD pumps with double cable cover suitable for dual voltage 400/690 V (star/delta) motors from 11 kW to 30 kW
- Other voltages or 60 Hz frequency

GUARANTEE

2 years subject to terms and conditions

PERFORMANCE RANGE

50 Hz n= 2900 1/min

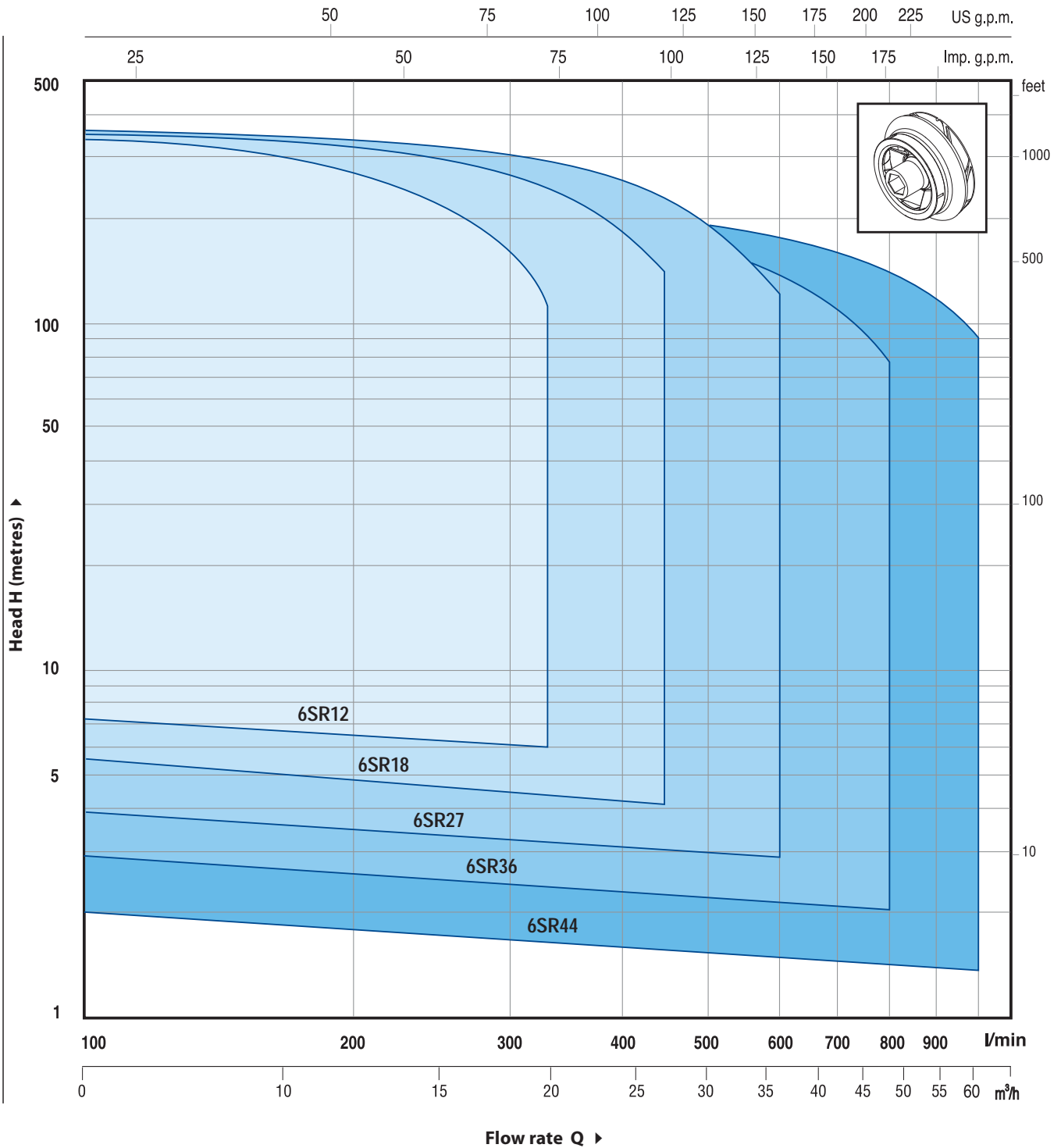

DESCRIPTION

6 SR 12 / 8 - PD or HYD

- Borehole diameter in inches _____
- Series _____
- Flow rate in m³/h at the point of highest efficiency _____
- Number of stages _____
- PD:** pump with "PEDROLLO" motor _____
- HYD:** pump without motor _____

CHARACTERISTIC CURVES AND PERFORMANCE DATA

50 Hz n= 2900 1/min

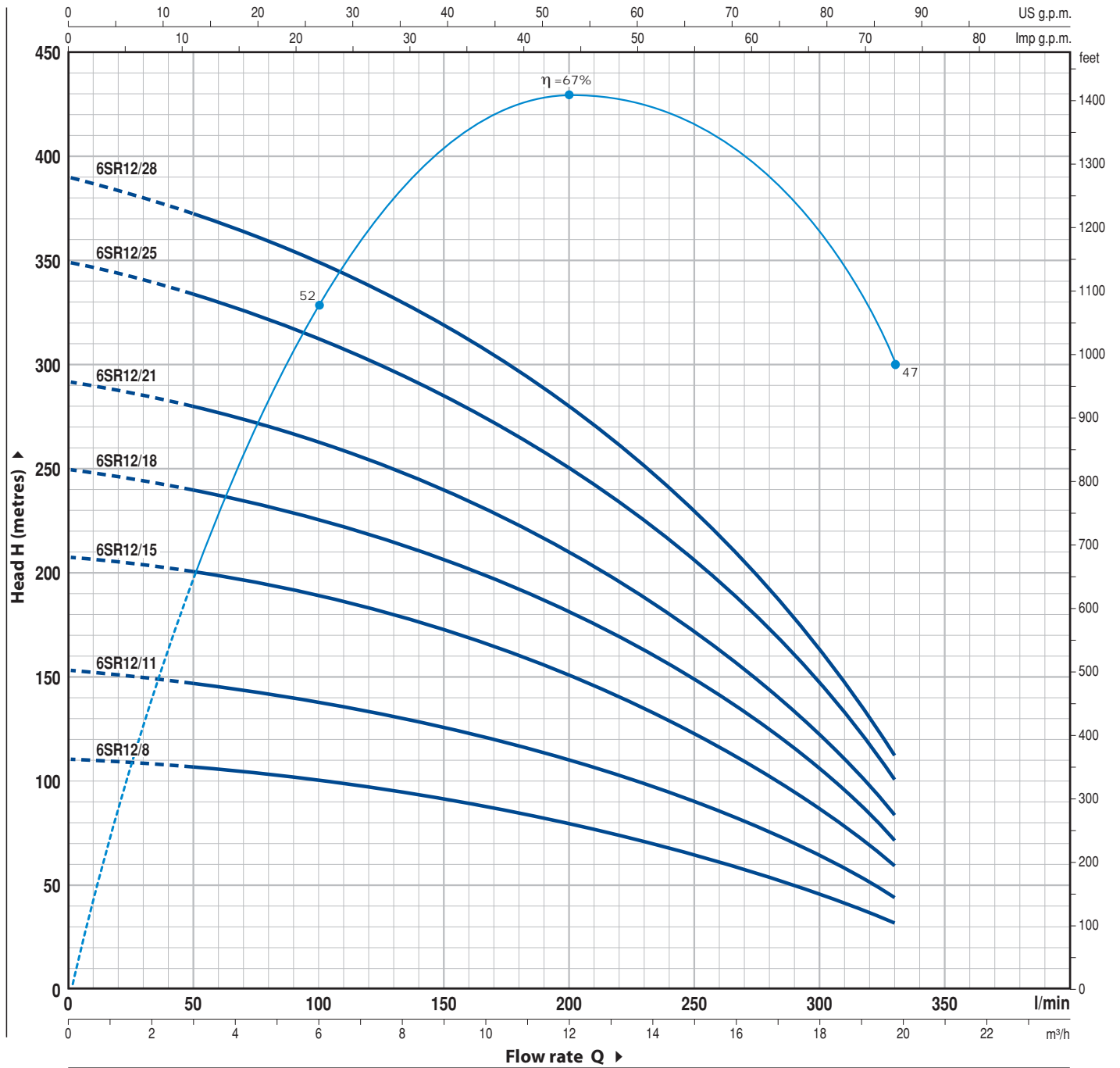

MODEL	POWER		Q	Flow rate													
	kW	HP		0	3.0	6.0	9.0	12.0	15.0	18.0	19.8						
Three-phase				0	50	100	150	200	250	300	330						
6SR12/8	4	5.5	H metres	111	106	100	91	80	66	47	32						
6SR12/11	5.5	7.5		153	146	138	125	110	91	65	44						
6SR12/15	7.5	10		208	199	189	171	150	124	88	60						
6SR12/18	9.2	12.5		250	239	225	205	180	149	106	72						
6SR12/21	11	15		292	279	263	239	210	174	124	84						
6SR12/25	13	17.5		349	331	313	285	250	206	147	100						
6SR12/28	15	20		390	371	350	319	280	231	165	112						

Q = Flow rate H = Total manometric head

Tolerance of characteristic curves in compliance with EN ISO 9906 App. A.

CHARACTERISTIC CURVES AND PERFORMANCE DATA

50 Hz n= 2900 1/min

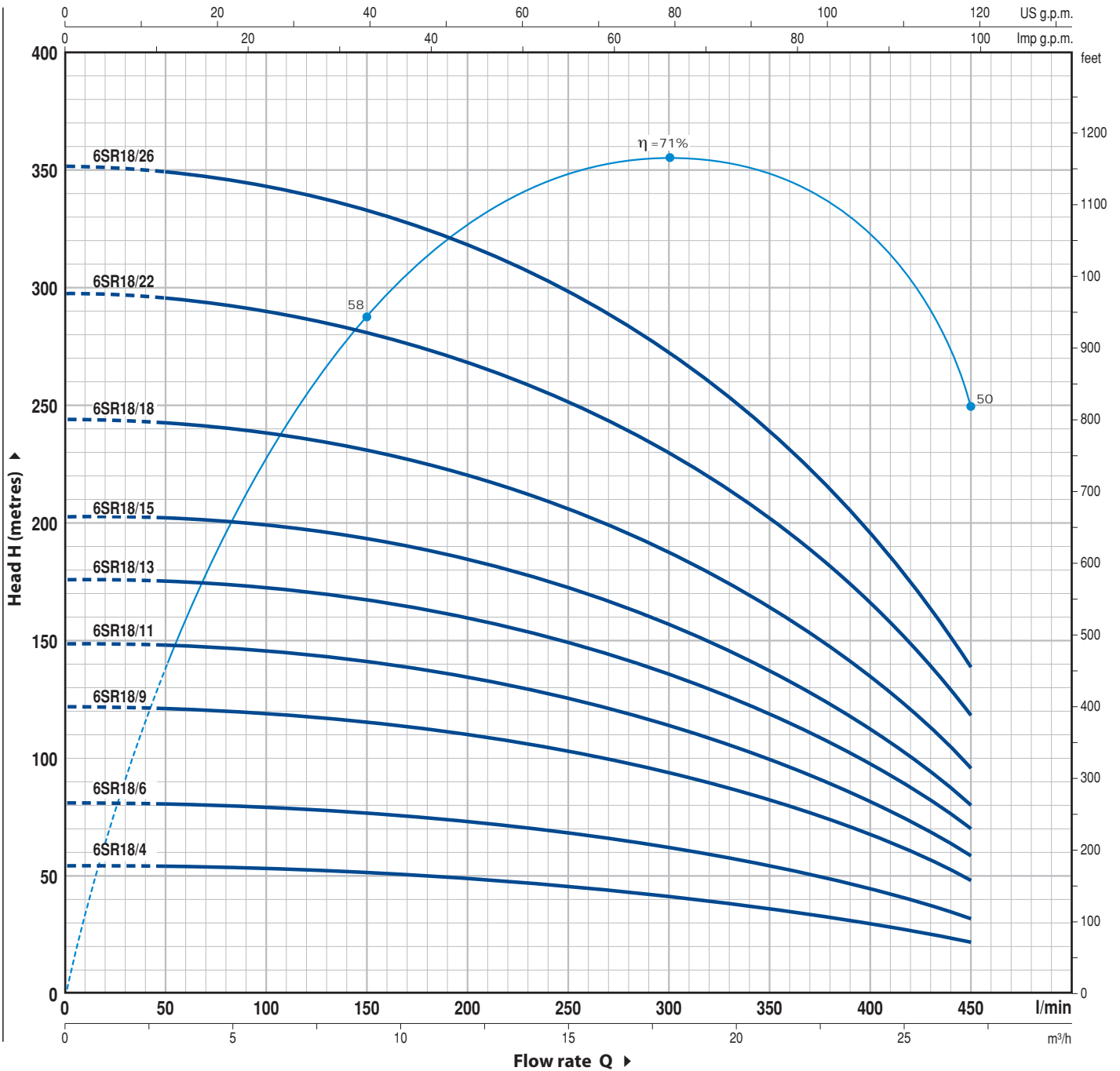

MODEL	POWER		Q	Flow rate (l/min)												
	kW	HP		0	3	6	9	12	15	18	21	24	27			
Three-phase				0	50	100	150	200	250	300	350	400	450			
6SR18/4	4	5.5	H metres	54	53.8	53	51	49	46	42	37	30	22			
6SR18/6	5.5	7.5		81	80.5	79	77	74	69	63	55	45	32			
6SR18/9	7.5	10		122	121	119	116	111	103	94	83	68	48			
6SR18/11	9.2	12.5		149	148	145.5	141	135	126	115	101	83	59			
6SR18/13	11	15		176	175	172	167	160	149	136	120	98	70			
6SR18/15	13	17.5		203	202	199	193	185	172	157	138	113	80			
6SR18/18	15	20		244	242	238	231	221	206	188	165	135	96			
6SR18/22	18.5	25		298	296	291	282	270	252	230	202	165	118			
6SR18/26	22	30		352	350	344	334	320	298	272	239	195	139			

Q = Flow rate H = Total manometric head

Tolerance of characteristic curves in compliance with EN ISO 9906 App. A.

CHARACTERISTIC CURVES AND PERFORMANCE DATA

50 Hz n = 2900 1/min

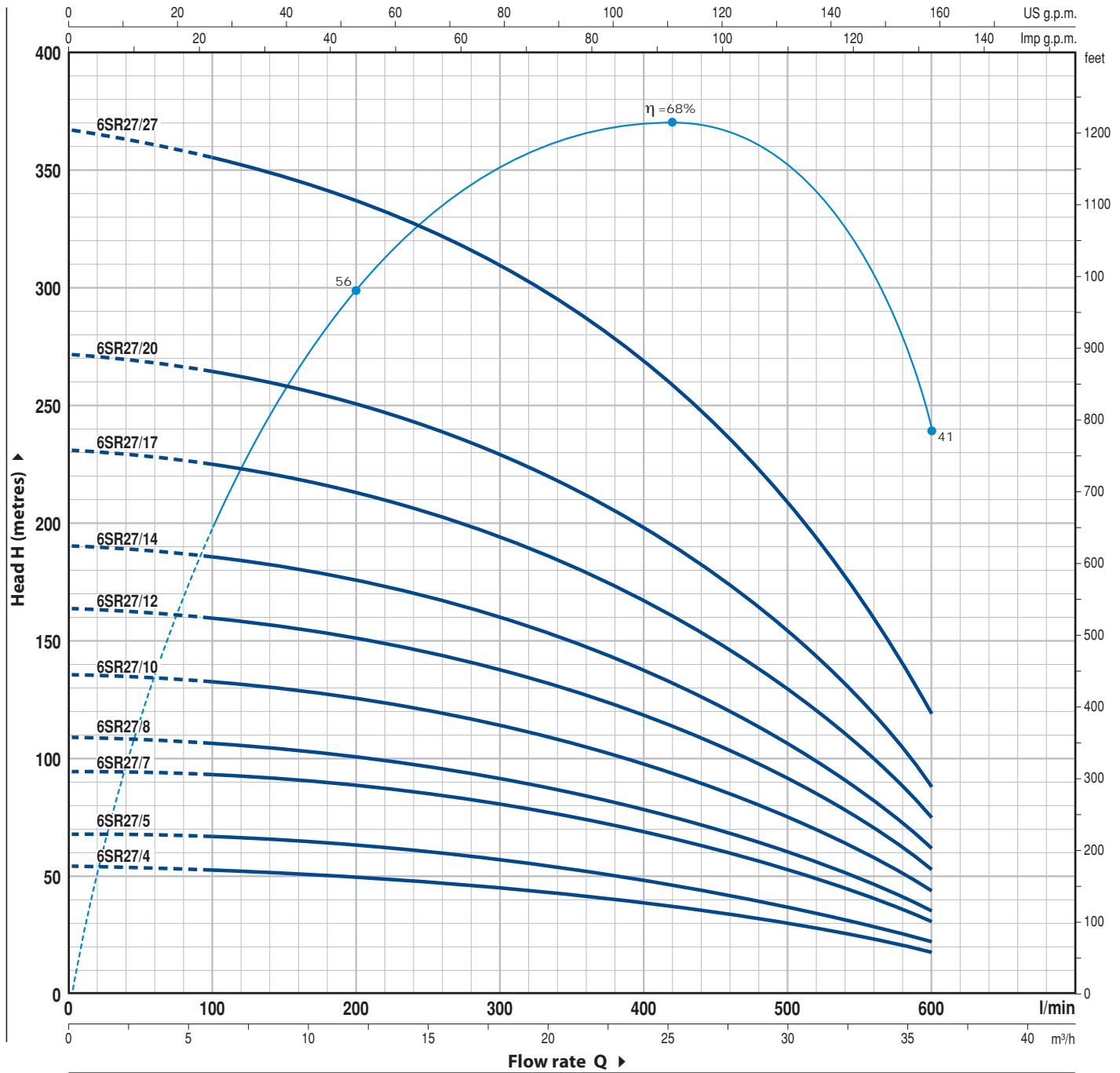

MODEL	POWER		Q	0	6	12	18	24	30	36
	kW	HP		0	100	200	300	400	500	600
Three-phase										
6SR27/4	4	5.5	H metres	54	53	49	45	40	30	18
6SR27/5	5.5	7.5		68	66	62	57	50	37	22
6SR27/7	7.5	10		95	92	87	80	70	52	31
6SR27/8	9.2	12.5		109	106	99	91	80	59	35
6SR27/10	11	15		136	132	124	114	100	74	44
6SR27/12	13	17.5		164	159	149	137	120	89	53
6SR27/14	15	20		191	185	174	160	140	104	62
6SR27/17	18.5	25		231	224	211	194	170	126	75
6SR27/20	22	30		272	264	248	228	200	148	88
6SR27/27	30	40		367	356	335	308	270	205	119

Q = Flow rate H = Total manometric head

Tolerance of characteristic curves in compliance with EN ISO 9906 App. A.

CHARACTERISTIC CURVES AND PERFORMANCE DATA

50 Hz n= 2900 1/min

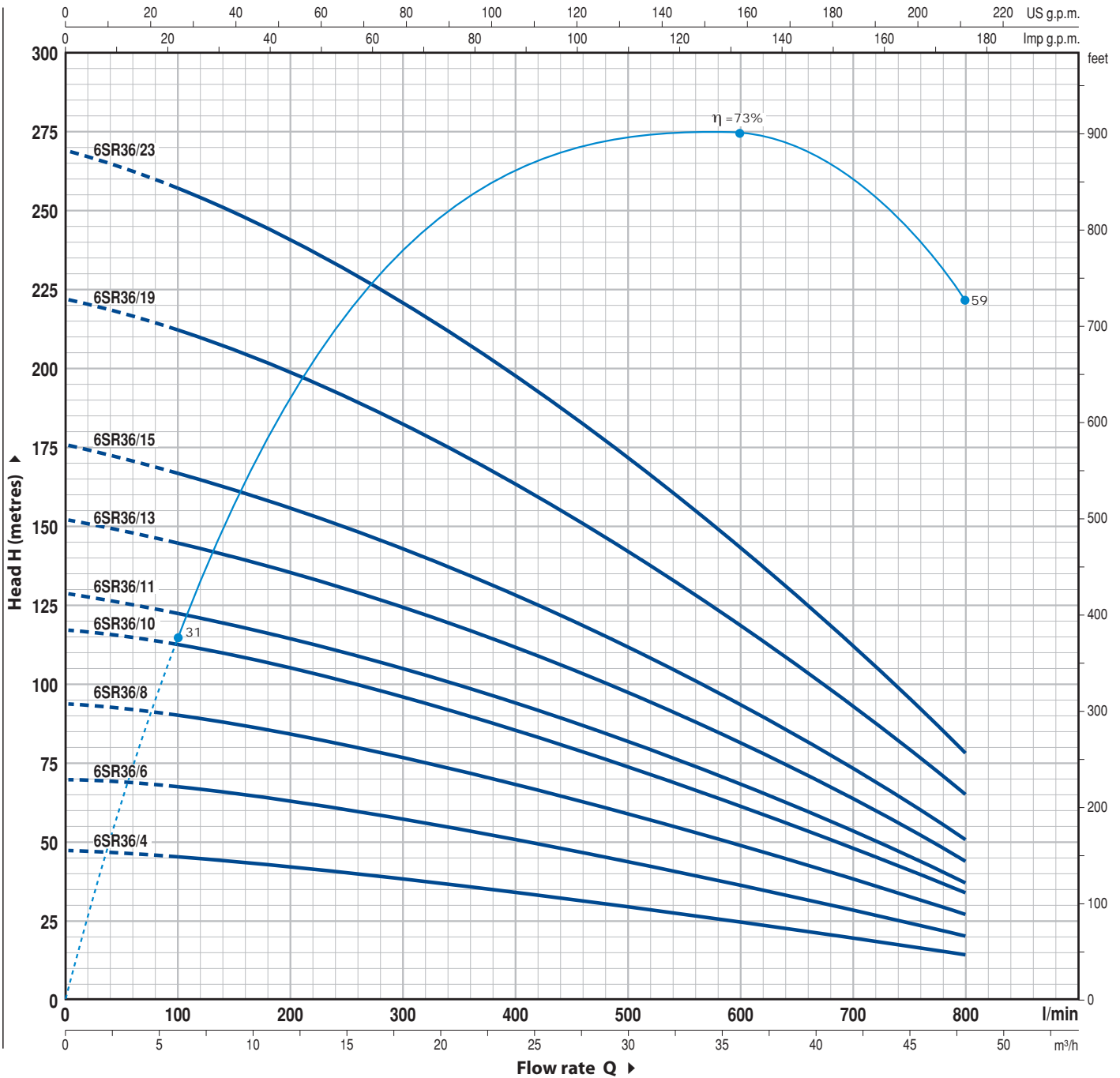

MODEL	POWER		Q	Flow rate (l/min)																			
	kW	HP		0	6	12	18	24	30	36	42	48											
Three-phase				0	100	200	300	400	500	600	700	800											
6SR36/4	4	5.5	H metres	47	45	42	38	34	29	25	19	14											
6SR36/6	5.5	7.5		70	67	63	57	51	44	37	29	20											
6SR36/8	7.5	10		94	89	84	76	68	59	50	39	27											
6SR36/10	9.2	12.5		117	111	105	95	85	74	62	48	34											
6SR36/11	11	15		129	123	115	105	93	81	68	53	37											
6SR36/13	13	17.5		152	145	136	124	110	96	81	63	44											
6SR36/15	15	20		176	167	157	143	127	110	93	72	51											
6SR36/19	18.5	25		222	212	199	181	161	140	118	92	65											
6SR36/23	22	30		269	256	241	219	195	169	143	111	78											

Q = Flow rate H = Total manometric head

Tolerance of characteristic curves in compliance with EN ISO 9906 App. A.

CHARACTERISTIC CURVES AND PERFORMANCE DATA

50 Hz n= 2900 1/min

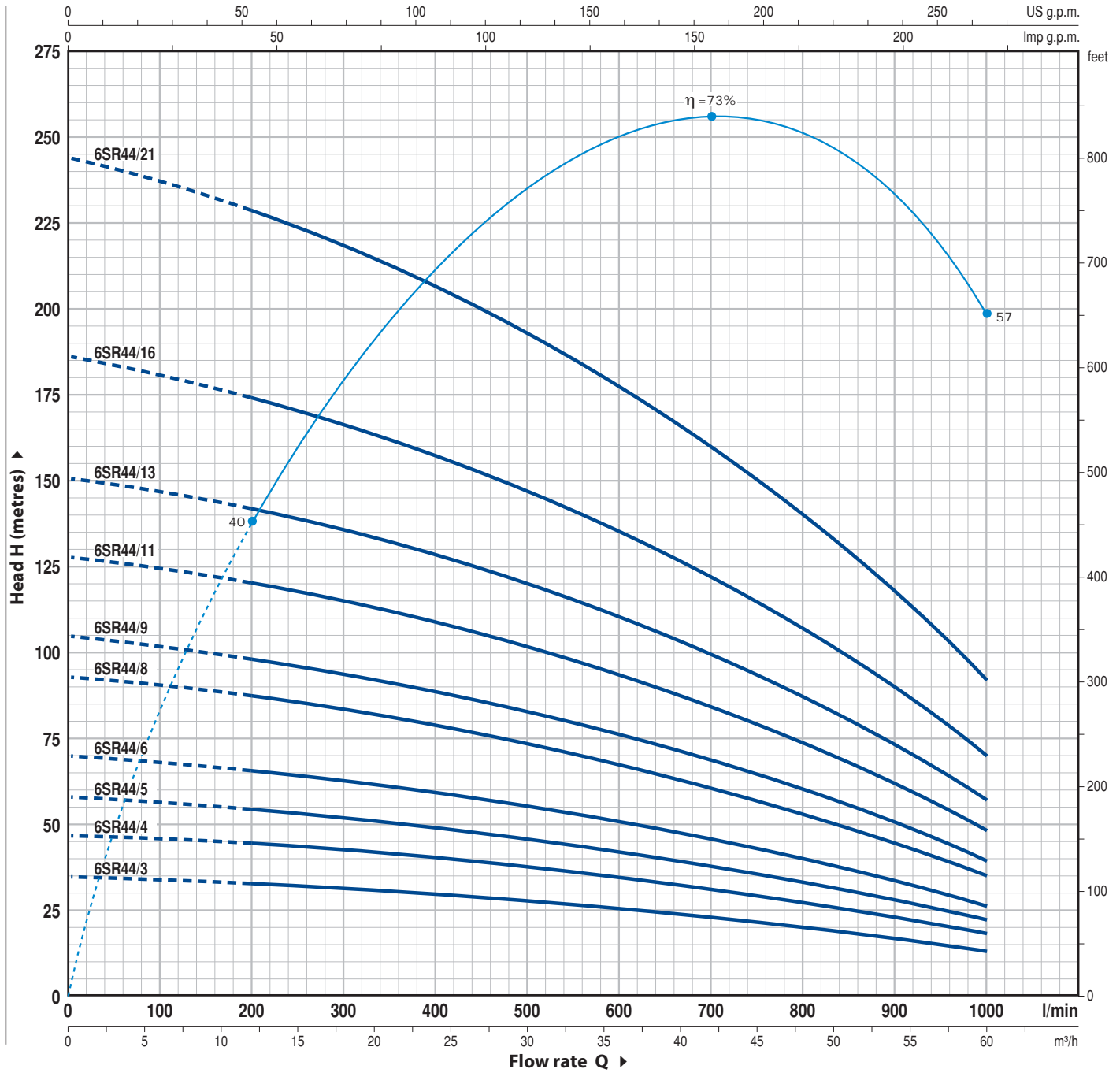

MODEL	POWER		Q	Flow rate (l/min)											
	kW	HP		0	12	18	24	30	36	42	48	54	60		
Three-phase				0	200	300	400	500	600	700	800	900	1000		
6SR44/3	4	5.5	H metres	35	33	31	30	28	26	23	20	17	13		
6SR44/4	5.5	7.5		47	44	42	40	37	34	31	27	23	18		
6SR44/5	7.5	10		58	54	52	49	46	43	38	33	28	22		
6SR44/6	9.2	12.5		70	65	62	59	56	51	46	40	34	26		
6SR44/8	11	15		93	87	83	79	74	68	61	53	45	35		
6SR44/9	13	17.5		105	98	93	89	83	77	69	60	51	39		
6SR44/11	15	20		128	120	114	109	102	94	84	73	62	48		
6SR44/13	18.5	25		151	141	135	128	120	111	99	86	73	57		
6SR44/16	22	30		186	174	166	158	148	136	122	106	90	70		
6SR44/21	30	40		244	228	218	207	194	179	160	139	118	92		

Q = Flow rate H = Total manometric head

Tolerance of characteristic curves in compliance with EN ISO 9906 App. A.

INSTALLATION EXAMPLE

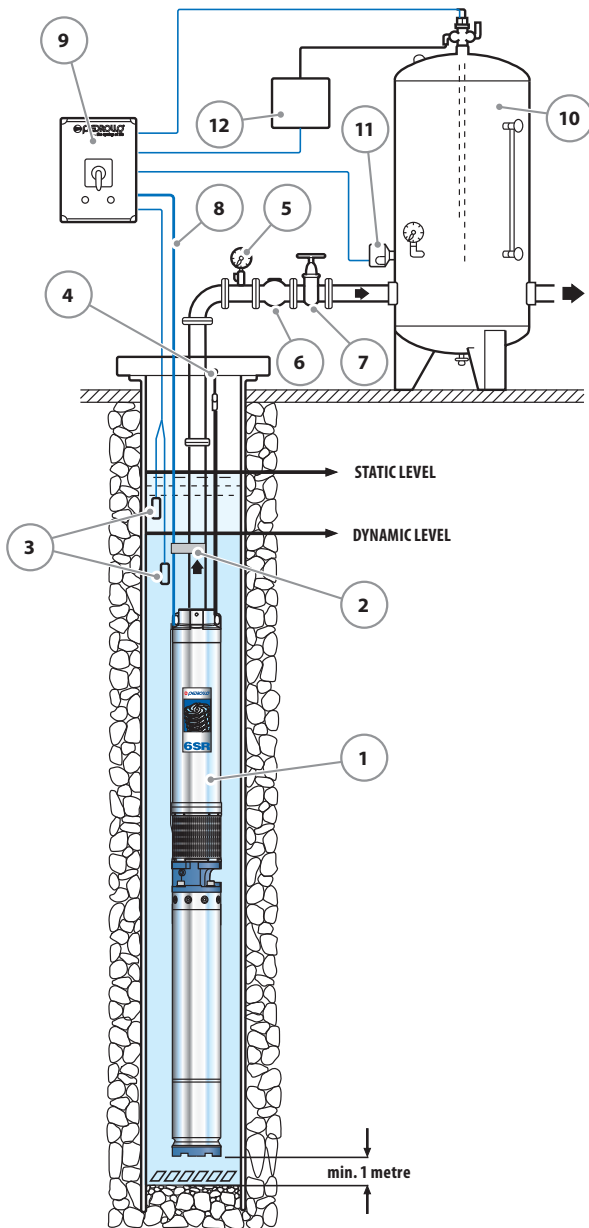

Vertical installation

→ The 6SR series pumps should be installed in boreholes of at least 6" (150 mm) in diameter. The pump should be lowered into the borehole, by means of the delivery pipe, to such a depth (min. 50 cm and at least one metre from the bottom) that it is completely immersed during operation when the level of water in the borehole may reduce. It is good practice to secure the pump by attaching a stainless steel cable to the anchorage points present on the delivery body.

COMPONENTS

- 1) Submersible pump
- 2) Power cable clamps
- 3) Level probes
- 4) Pump anchorage
- 5) Pressure gauge
- 6) Non-return valve
- 7) Gate valve; for flow rate regulation
- 8) Power cable
- 9) Control box
- 10) Pressure vessel
- 11) Pressure switch
- 12) Electro valve/electro-compressor

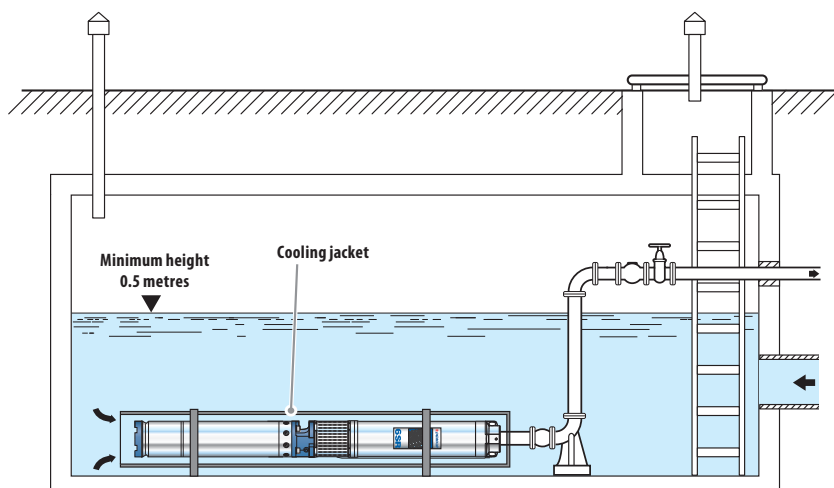

Cooling jacket

It is necessary to fit the pump with a cooling jacket in installations in storage tanks, rivers and lakes in order to prevent the motor from overheating.

POS.	DESCRIPTION	CONSTRUCTION CHARACTERISTICS
1	DELIVERY BODY	Stainless steel AISI 304 complete with threaded delivery port in compliance with ISO 228/1
2	NON-RETURN VALVE	Stainless steel AISI 304
3	MOTOR BRACKET	Nickel-plated cast iron, in compliance with NEMA standards
4	IMPELLERS	Special-rubber coated Noryl GFN2V
5	DIFFUSERS	Noryl GFN2V
6	DIFFUSOR CASING	Stainless steel AISI 304
7	PUMP SHAFT	Stainless steel AISI 304
8	PUMP BEARINGS	Special-technopolymer housing with stainless steel AISI 316, chrome oxide coated, sand resistant shaft bushing
9	DRIVE COUPLING	Stainless steel AISI 420
10	FILTER	Stainless steel AISI 304
11	CABLE COVER	Stainless steel AISI 304
12	MOTOR 6"	6PD = "PEDROLLO"

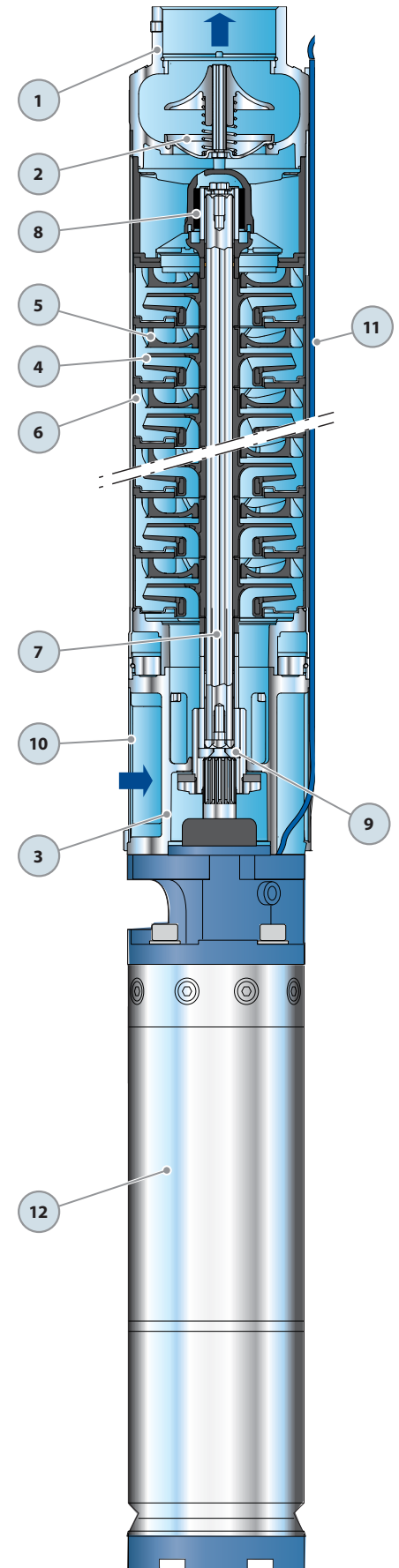

تهران، کیلومتر ۲۱ بزرگراه لشگری (جاده مخصوص کرج)
روبروی پالایشگاه نفت پارس، پلاک ۱۲

POS.	DESCRIPTION	CONSTRUCTION CHARACTERISTICS
1	DELIVERY BODY	Stainless steel AISI 304 complete with threaded delivery port in compliance with ISO 228/1
2	NON-RETURN VALVE	Stainless steel AISI 304
3	MOTOR BRACKET	Nickel-plated cast iron, in compliance with NEMA standards
4	IMPELLERS	Special-rubber coated Noryl GFN2V
5	DIFFUSERS	Noryl GFN2V
6	DIFFUSOR CASING	Stainless steel AISI 304
7	PUMP SHAFT	Stainless steel AISI 304
8	PUMP BEARINGS	Special-technopolymer housing with stainless steel AISI 316, chrome oxide coated, sand resistant shaft bushing
9	DRIVE COUPLING	Stainless steel AISI 420
10	FILTER	Stainless steel AISI 304
11	CABLE COVER	Stainless steel AISI 304
12	MOTOR 6"	6PD = "PEDROLLO"

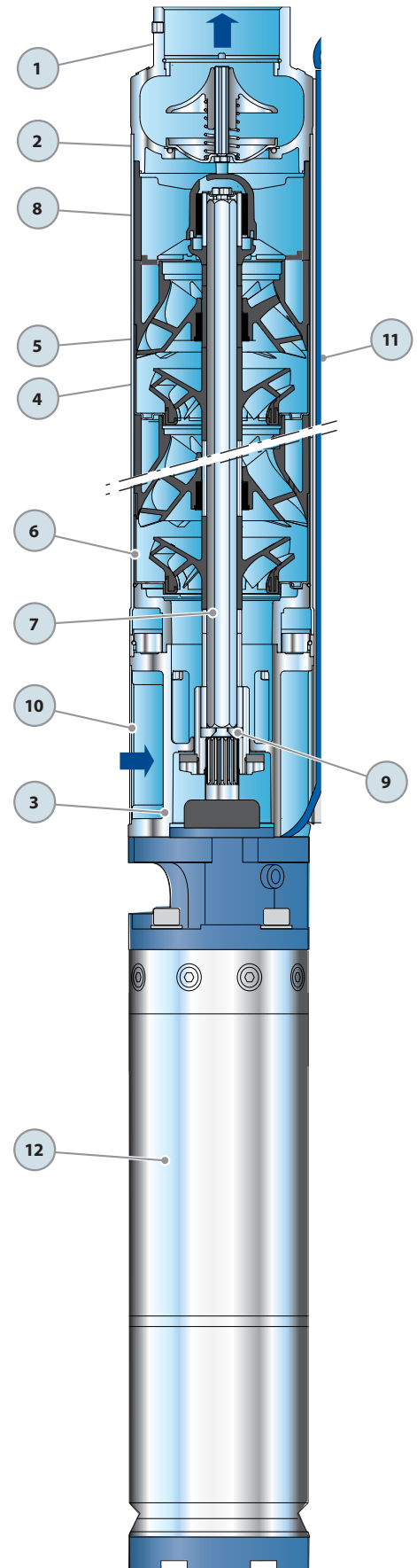

تهران، کیلومتر ۲۱ بزرگراه لشگری (جاده مخصوص کرج)

روبروی پالایشگاه نفت پارس، پلاک ۱۲

DIMENSIONS AND WEIGHT

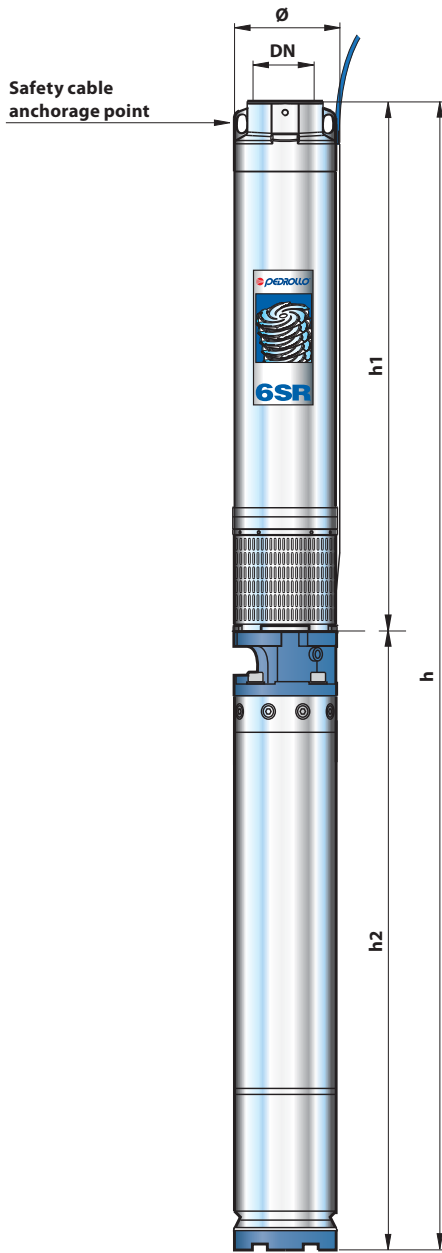

MODEL	PORT DN	Ø	DIMENSIONS mm			kg 3~
			h1	h2	h	
Three-phase						
6 SR 12/8 - PD	3"	149.5	719	633	1352	53.8
6 SR 12/11 - PD			849	667	1516	60.9
6 SR 12/15 - PD			1068	698	1766	66.8
6 SR 12/18 - PD			1198	731	1929	73.0
6 SR 12/21 - PD			1328	826	2154	83.9
6 SR 12/25 - PD			1502	894	2396	96.0
6 SR 12/28 - PD			1632	894	2526	98.1
6 SR 18/4 - PD			545	633	1178	49.6
6 SR 18/6 - PD			632	667	1299	53.6
6 SR 18/9 - PD			762	698	1460	60.3
6 SR 18/11 - PD			849	731	1580	67.0
6 SR 18/13 - PD			981	826	1807	76.9
6 SR 18/15 - PD			1068	894	1962	84.6
6 SR 18/18 - PD			1198	894	2092	87.6
6 SR 18/22 - PD			1371	959	2330	99.7
6 SR 18/26 - PD			1545	1116	2661	125.7
6 SR 27/4 - PD			583	633	1216	47.9
6 SR 27/5 - PD			636	667	1303	53.5
6 SR 27/7 - PD			742	698	1440	58.8
6 SR 27/8 - PD			795	731	1526	63.0
6 SR 27/10 - PD			901	826	1727	74.1
6 SR 27/12 - PD			1051	894	1945	83.6
6 SR 27/14 - PD			1157	894	2051	85.9
6 SR 27/17 - PD			1316	959	2275	97.5
6 SR 27/20 - PD			1474	1116	2590	123.0
6 SR 27/27 - PD			1845	1243	3088	135.8
6 SR 36/4 - PD			823	633	1456	55.4
6 SR 36/6 - PD			1049	667	1716	64.0
6 SR 36/8 - PD			1275	698	1973	71.0
6 SR 36/10 - PD			1501	731	2232	76.2
6 SR 36/11 - PD			1613	826	2439	90.0
6 SR 36/13 - PD			1839	894	2733	102.0
6 SR 36/15 - PD			2065	894	2959	107.0
6 SR 36/19 - PD			2517	959	3476	121.0
6 SR 36/23 - PD			2969	1116	4085	154.0
6 SR 44/3 - PD			710	633	1343	54.0
6 SR 44/4 - PD			823	667	1490	57.5
6 SR 44/5 - PD			936	698	1634	63.1
6 SR 44/6 - PD			1049	731	1780	70.0
6 SR 44/8 - PD			1275	826	2101	82.2
6 SR 44/9 - PD			1388	894	2282	92.0
6 SR 44/11 - PD			1613	894	2507	97.0
6 SR 44/13 - PD	1839	959	2798	110.0		
6 SR 44/16 - PD	2178	1116	3294	141.0		
6 SR 44/21 - PD	2743	1243	3986	154.3		

DIMENSIONS AND WEIGHT



MODEL	PORT DN	DIMENSIONS mm		kg
		Ø	h	
6 SR 12/8 - HYD	3"	149.5	719	19.8
6 SR 12/11 - HYD			849	24.9
6 SR 12/15 - HYD			1068	27.8
6 SR 12/18 - HYD			1198	31.0
6 SR 12/21 - HYD			1328	33.9
6 SR 12/25 - HYD			1502	39.0
6 SR 12/28 - HYD			1632	41.1
6 SR 18/4 - HYD			545	15.6
6 SR 18/6 - HYD			632	17.6
6 SR 18/9 - HYD			762	21.3
6 SR 18/11 - HYD			849	25.0
6 SR 18/13 - HYD			981	26.9
6 SR 18/15 - HYD			1068	27.6
6 SR 18/18 - HYD			1198	30.6
6 SR 18/22 - HYD			1371	34.7
6 SR 18/26 - HYD			1545	38.7
6 SR 27/4 - HYD			583	13.9
6 SR 27/5 - HYD			636	17.5
6 SR 27/7 - HYD			742	19.8
6 SR 27/8 - HYD			795	21.0
6 SR 27/10 - HYD			901	24.1
6 SR 27/12 - HYD			1051	26.6
6 SR 27/14 - HYD			1157	28.9
6 SR 27/17 - HYD			1316	32.5
6 SR 27/20 - HYD			1474	36.0
6 SR 27/27 - HYD			1845	44.8
6 SR 36/4 - HYD			823	21.4
6 SR 36/6 - HYD			1049	28.0
6 SR 36/8 - HYD			1275	32.0
6 SR 36/10 - HYD			1501	34.2
6 SR 36/11 - HYD			1613	40.0
6 SR 36/13 - HYD			1839	45.0
6 SR 36/15 - HYD			2065	50.0
6 SR 36/19 - HYD			2517	56.0
6 SR 36/23 - HYD			2969	67.0
6 SR 44/3 - HYD			710	20.0
6 SR 44/4 - HYD			823	21.5
6 SR 44/5 - HYD			936	24.1
6 SR 44/6 - HYD			1049	28.0
6 SR 44/8 - HYD			1275	32.2
6 SR 44/9 - HYD			1388	35.0
6 SR 44/11 - HYD			1613	40.0
6 SR 44/13 - HYD	1839	45.0		
6 SR 44/16 - HYD	2178	54.0		
6 SR 44/21 - HYD	2743	63.3		